



43 Years'
Chapterwise Topicwise
Solved Papers

2021-1979

IIT JEE

JEE Main & Advanced

Mathematics

Amit M. Agarwal

43 Years'

Chapterwise Topicwise
Solved Papers

2021-1979

IIT JEE

JEE Main & Advanced

Mathematics

Amit M Agarwal

 **arihant**

Arihant Prakashan (Series), Meerut



Arihant Prakashan (Series), Meerut

All Rights Reserved

☞ © Author

No part of this publication may be re-produced, stored in a retrieval system or by any means, electronic, mechanical, photocopying, recording, scanning, web or otherwise without the written permission of the publisher. Arihant has obtained all the information in this book from the sources believed to be reliable and true. However, Arihant or its editors or authors or illustrators don't take any responsibility for the absolute accuracy of any information published and the damage or loss suffered thereupon.

All disputes subject to Meerut (UP) jurisdiction only.

☞ Administrative & Production Offices

Regd. Office

'Ramchhaya' 4577/15, Agarwal Road, Darya Ganj, New Delhi -110002
Tele: 011- 47630600, 43518550

Head Office

Kalindi, TP Nagar, Meerut (UP) - 250002, Tel: 0121-7156203, 7156204

☞ Sales & Support Offices

Agra, Ahmedabad, Bengaluru, Bareilly, Chennai, Delhi, Guwahati, Hyderabad, Jaipur, Jhansi, Kolkata, Lucknow, Nagpur & Pune.

☞ ISBN 978-93-25796-13-3

PO No : TXT-XX-XXXXXXX-X-XX

Published by Arihant Publications (India) Ltd.

For further information about the books published by Arihant, log on to www.arihantbooks.com or e-mail at info@arihantbooks.com

Follow us on



CONTENTS

1. Complex Numbers	1-28
2. Theory of Equations	29-50
3. Sequences and Series	51-75
4. Permutations and Combinations	76-88
5. Binomial Theorem	89-102
6. Probability	103-134
7. Matrices and Determinants	135-170
8. Functions	171-187
9. Limit, Continuity and Differentiability	188-238
10. Application of Derivatives	239-277
11. Indefinite Integration	278-293
12. Definite Integration	294-328
13. Area	329-353
14. Differential Equations	354-378
15. Straight Line and Pair of Straight Lines	379-404

16. Circle	405-439
17. Parabola	440-457
18. Ellipse	458-473
19. Hyperbola	474-485
20. Trigonometrical Ratios and Identities	486-498
21. Trigonometrical Equations	499-514
22. Inverse Circular Functions	515-525
23. Properties of Triangles	526-547
24. Vectors	548-579
25. 3D Geometry	580-605
26. Miscellaneous	606-632
• JEE Advanced Solved Paper 2021	1-16

SYLLABUS

JEE MAIN

UNIT I Sets, Relations and Functions

Sets and their representation, Union, intersection and complement of sets and their algebraic properties, Power set, Relation, Types of relations, equivalence relations, functions, one-one, into and onto functions, composition of functions.

UNIT II Complex Numbers and Quadratic Equations

Complex numbers as ordered pairs of reals, Representation of complex numbers in the form $a+ib$ and their representation in a plane, Argand diagram, algebra of complex numbers, modulus and argument (or amplitude) of a complex number, square root of a complex number, triangle inequality, Quadratic equations in real and complex number system and their solutions. Relation between roots and co-efficients, nature of roots, formation of quadratic equations with given roots.

UNIT III Matrices and Determinants

Matrices, algebra of matrices, types of matrices, determinants and matrices of order two and three. Properties of determinants, evaluation of determinants, area of triangles using determinants. Adjoint and evaluation of inverse of a square matrix using determinants and elementary transformations, Test of consistency and solution of simultaneous linear equations in two or three variables using determinants and matrices.

UNIT IV Permutations and Combinations

Fundamental principle of counting, permutation as an arrangement and combination as selection, Meaning of $P(n,r)$ and $C(n,r)$, simple applications.

UNIT V Mathematical Induction

Principle of Mathematical Induction and its simple applications.

UNIT VI Binomial Theorem and its Simple Applications

Binomial theorem for a positive integral index, general term and middle term, properties of Binomial coefficients and simple applications.

UNIT VII Sequences and Series

Arithmetic and Geometric progressions, insertion of arithmetic, geometric means between two given numbers. Relation between AM and GM Sum upto n terms of special series: $\sum n$, $\sum n^2$, $\sum n^3$. Arithmetic - Geometric progression.

UNIT VIII Limit, Continuity and Differentiability

Real valued functions, algebra of functions, polynomials, rational, trigonometric, logarithmic and exponential functions, inverse functions. Graphs of simple functions. Limits, continuity and differentiability. Differentiation of the sum, difference, product and quotient of two functions. Differentiation of trigonometric, inverse trigonometric, logarithmic, exponential, composite and implicit functions; derivatives of order upto two. Rolle's and Lagrange's Mean Value Theorems. Applications of derivatives: Rate of change of quantities, monotonic - increasing and decreasing functions, Maxima and minima of functions of one variable, tangents and normals.

UNIT IX Integral Calculus

Integral as an anti - derivative. Fundamental integrals involving algebraic, trigonometric, exponential and logarithmic functions. Integration by substitution, by

parts and by partial fractions. Integration using trigonometric identities. Evaluation of simple integrals of the type

$$\int \frac{dx}{x^2 \pm a^2}, \int \frac{dx}{\sqrt{x^2 \pm a^2}}, \int \frac{dx}{a^2 - x^2}, \int \frac{dx}{\sqrt{a^2 - x^2}},$$

$$\int \frac{dx}{ax^2 + bx + c}, \int \frac{dx}{\sqrt{ax^2 + bx + c}}, \int \frac{(px + q) dx}{ax^2 + bx + c},$$

$$\int \frac{(px + q) dx}{\sqrt{ax^2 + bx + c}}, \int \sqrt{a^2 \pm x^2} dx \quad \text{and} \quad \int \sqrt{x^2 - a^2} dx$$

Integral as limit of a sum. Fundamental Theorem of Calculus. Properties of definite integrals. Evaluation of definite integrals, determining areas of the regions bounded by simple curves in standard form.

UNIT X Differential Equations

Ordinary differential equations, their order and degree. Formation of differential equations. Solution of differential equations by the method of separation of variables, solution of homogeneous and linear differential equations of the type

UNIT XI Coordinate Geometry

Cartesian system of rectangular coordinates in a plane, distance formula, section formula, locus and its equation, translation of axes, slope of a line, parallel and perpendicular lines, intercepts of a line on the coordinate axes.

Straight lines

Various forms of equations of a line, intersection of lines, angles between two lines, conditions for concurrence of three lines, distance of a point from a line, equations of internal and external bisectors of angles between two lines, coordinates of centroid, orthocentre and circumcentre of a triangle, equation of family of lines passing through the point of intersection of two lines.

Circles, Conic sections

Standard form of equation of a circle, general form of the equation of a circle, its radius and centre, equation of a

circle when the end points of a diameter are given, points of intersection of a line and a circle with the centre at the origin and condition for a line to be tangent to a circle, equation of the tangent. Sections of cones, equations of conic sections (parabola, ellipse and hyperbola) in standard forms, condition for $y=mx + c$ to be a tangent and point (s) of tangency.

UNIT XII Three Dimensional Geometry

Coordinates of a point in space, distance between two points, section formula, direction ratios and direction cosines, angle between two intersecting lines. Skew lines, the shortest distance between them and its equation. Equations of a line and a plane in different forms, intersection of a line and a plane, coplanar lines.

UNIT XIII Vector Algebra

Vectors and scalars, addition of vectors, components of a vector in two dimensions and three dimensional space, scalar and vector products, scalar and vector triple product.

UNIT XIV Statistics and Probability

Measures of Dispersion: Calculation of mean, median, mode of grouped and ungrouped data. Calculation of standard deviation, variance and mean deviation for grouped and ungrouped data.

Probability: Probability of an event, addition and multiplication theorems of probability, Baye's theorem, probability distribution of a random variate, Bernoulli trials and Binomial distribution.

UNIT XV Trigonometry

Trigonometrical identities and equations. Trigonometrical functions. Inverse trigonometrical functions and their properties. Heights and Distances.

UNIT XVI Mathematical Reasoning

Statements, logical operations And, or, implies, implied by, if and only if. Understanding of tautology, contradiction, converse and contra positive.

JEE ADVANCED

Algebra

Algebra of complex numbers, addition, multiplication, conjugation, polar representation, properties of modulus and principal argument, triangle inequality, cube roots of unity, geometric interpretations.

Quadratic equations with real coefficients, relations between roots and coefficients, formation of quadratic equations with given roots, symmetric functions of roots.

Arithmetic, geometric and harmonic progressions, arithmetic, geometric and harmonic means, sums of finite arithmetic and geometric progressions, infinite geometric series, sums of squares and cubes of the first n natural numbers.

Logarithms and their Properties, Permutations and combinations, Binomial theorem for a positive integral index, properties of binomial coefficients.

Matrices

Matrices as a rectangular array of real numbers, equality of matrices, addition, multiplication by a scalar and product of matrices, transpose of a matrix, determinant of a square matrix of order up to three, inverse of a square matrix of order up to three, properties of these matrix operations, diagonal, symmetric and skew-symmetric matrices and their properties, solutions of simultaneous linear equations in two or three variables.

Probability

Addition and multiplication rules of probability, conditional probability, independence of events, computation of probability of events using permutations and combinations.

Trigonometry

Trigonometric functions, their periodicity and graphs, addition and subtraction formulae, formulae involving multiple and sub-multiple angles, general solution of trigonometric equations.

Relations between sides and angles of a triangle, sine rule, cosine rule, half-angle formula and the area of a triangle, inverse trigonometric functions (principal value only).

Analytical Geometry

Two Dimensions Cartesian coordinates, distance between two points, section formulae, shift of origin.

Equation of a straight line in various forms, angle between two lines, distance of a point from a line. Lines through the point of intersection of two given lines, equation of the bisector of the angle between two lines, concurrency of lines, centroid, orthocentre, incentre and circumcentre of a triangle.

Equation of a circle in various forms, equations of tangent, normal and chord.

Parametric equations of a circle, intersection of a circle with a straight line or a circle, equation of a circle through the points of intersection of two circles and those of a circle and a straight line.

Equations of a parabola, ellipse and hyperbola in standard form, their foci, directrices and eccentricity, parametric equations, equations of tangent and normal.

Locus Problems, Three Dimensions Direction cosines and direction ratios, equation of a straight line in space, equation of a plane, distance of a point from a plane.

Differential Calculus

Real valued functions of a real variable, into, onto and one-to-one functions, sum, difference, product and quotient of two functions, composite functions, absolute value, polynomial, rational, trigonometric, exponential and logarithmic functions.

Limit and continuity of a function, limit and continuity of the sum, difference, product and quotient of two functions, l'Hospital rule of evaluation of limits of functions.

Even and odd functions, inverse of a function, continuity of composite functions, intermediate value property of continuous functions.

Derivative of a function, derivative of the sum, difference, product and quotient of two functions, chain rule, derivatives of polynomial, rational, trigonometric, inverse trigonometric, exponential and logarithmic functions.

Derivatives of implicit functions, derivatives up to order two, geometrical interpretation of the derivative, tangents and normals, increasing and decreasing functions, maximum and minimum values of a function, applications of Rolle's Theorem and Lagrange's Mean Value Theorem.

Integral Calculus

Integration as the inverse process of differentiation, indefinite integrals of standard functions, definite integrals and their properties, application of the Fundamental Theorem of Integral Calculus.

Integration by parts, integration by the methods of substitution and partial fractions, application of definite integrals to the determination of areas involving simple curves.

Formation of ordinary differential equations, solution of homogeneous differential equations, variables separable method, linear first order differential equations.

Vectors

Addition of vectors, scalar multiplication, scalar products, dot and cross products, scalar triple products and their geometrical interpretations.

1

Complex Numbers

Topic 1 Complex Number in Iota Form

Objective Questions I (Only one correct option)

1. Let $z \in C$ with $\text{Im}(z) = 10$ and it satisfies $\frac{2z - n}{2z + n} = 2i - 1$

for some natural number n , then (2019 Main, 12 April II)

- (a) $n = 20$ and $\text{Re}(z) = -10$ (b) $n = 40$ and $\text{Re}(z) = 10$
(c) $n = 40$ and $\text{Re}(z) = -10$ (d) $n = 20$ and $\text{Re}(z) = 10$

2. All the points in the set $S = \left\{ \frac{\alpha + i}{\alpha - i} : \alpha \in \mathbf{R} \right\}$ ($i = \sqrt{-1}$) lie on a (2019 Main, 9 April I)

- (a) circle whose radius is $\sqrt{2}$.
(b) straight line whose slope is -1 .
(c) circle whose radius is 1 .
(d) straight line whose slope is 1 .

3. Let $z \in C$ be such that $|z| < 1$. If $\omega = \frac{5 + 3z}{5(1 - z)}$, then (2019 Main, 9 April II)

- (a) $4 \text{Im}(\omega) > 5$ (b) $5 \text{Re}(\omega) > 1$
(c) $5 \text{Im}(\omega) < 1$ (d) $5 \text{Re}(\omega) > 4$

4. Let $\left(-2 - \frac{1}{3}i\right)^3 = \frac{x + iy}{27}$ ($i = \sqrt{-1}$), where x and y are real numbers, then $y - x$ equals (2019 Main, 11 Jan I)

- (a) 91 (b) 85 (c) -85 (d) -91

5. Let $A = \left\{ \theta \in \left(-\frac{\pi}{2}, \pi\right) : \frac{3 + 2i \sin \theta}{1 - 2i \sin \theta} \text{ is purely imaginary} \right\}$

Then, the sum of the elements in A is (2019 Main, 9 April I)

- (a) $\frac{3\pi}{4}$ (b) $\frac{5\pi}{6}$ (c) π (d) $\frac{2\pi}{3}$

6. A value of θ for which $\frac{2 + 3i \sin \theta}{1 - 2i \sin \theta}$ is purely imaginary, is (2016 Main)

- (a) $\frac{\pi}{3}$ (b) $\frac{\pi}{6}$ (c) $\sin^{-1}\left(\frac{\sqrt{3}}{4}\right)$ (d) $\sin^{-1}\left(\frac{1}{\sqrt{3}}\right)$

7. If $\begin{vmatrix} 6i & -3i & 1 \\ 4 & 3i & -1 \\ 20 & 3 & i \end{vmatrix} = x + iy$, then (1998, 2M)

- (a) $x = 3, y = 1$ (b) $x = 1, y = 1$ (c) $x = 0, y = 3$ (d) $x = 0, y = 0$

8. The value of sum $\sum_{n=1}^{13} (i^n + i^{n+1})$, where $i = \sqrt{-1}$, equals (1998, 2M)

- (a) i (b) $i - 1$ (c) $-i$ (d) 0

9. The smallest positive integer n for which $\left(\frac{1+i}{1-i}\right)^n = 1$, is (1980, 2M)

- (a) 8 (b) 16 (c) 12 (d) None of these

Objective Question II

(One or more than one correct option)

10. Let a, b, x and y be real numbers such that $a - b = 1$ and $y \neq 0$. If the complex number $z = x + iy$ satisfies $\text{Im}\left(\frac{az + b}{z + 1}\right) = y$, then which of the following is(are)

possible value(s) of x ? (2017 Adv.)

- (a) $1 - \sqrt{1 + y^2}$ (b) $-1 - \sqrt{1 - y^2}$
(c) $1 + \sqrt{1 + y^2}$ (d) $-1 + \sqrt{1 - y^2}$

Topic 2 Conjugate and Modulus of a Complex Number

Objective Questions I (Only one correct option)

1. The equation $|z - i| = |z - 1|$, $i = \sqrt{-1}$, represents (2019 Main, 12 April I)

- (a) a circle of radius $\frac{1}{2}$
(b) the line passing through the origin with slope 1
(c) a circle of radius 1
(d) the line passing through the origin with slope -1

2. If $a > 0$ and $z = \frac{(1+i)^2}{a-i}$, has magnitude $\sqrt{\frac{2}{5}}$, then \bar{z} is equal to (2019 Main, 10 April I)

- (a) $\frac{1}{5} - \frac{3}{5}i$ (b) $-\frac{1}{5} - \frac{3}{5}i$
(c) $-\frac{1}{5} + \frac{3}{5}i$ (d) $-\frac{3}{5} - \frac{1}{5}i$

2 Complex Numbers

3. Let z_1 and z_2 be two complex numbers satisfying $|z_1| = 9$ and $|z_2 - 3 - 4i| = 4$. Then, the minimum value of $|z_1 - z_2|$ is **(2019 Main, 12 Jan II)**
 (a) 1 (b) 2 (c) $\sqrt{2}$ (d) 0
4. If $\frac{z - \alpha}{z + \alpha}$ ($\alpha \in \mathbb{R}$) is a purely imaginary number and $|z| = 2$, then a value of α is **(2019 Main, 12 Jan I)**
 (a) $\sqrt{2}$ (b) $\frac{1}{2}$ (c) 1 (d) 2
5. Let z be a complex number such that $|z| + z = 3 + i$ (where $i = \sqrt{-1}$). Then, $|z|$ is equal to **(2019 Main, 11 Jan II)**
 (a) $\frac{\sqrt{34}}{3}$ (b) $\frac{5}{3}$ (c) $\frac{\sqrt{41}}{4}$ (d) $\frac{5}{4}$
6. A complex number z is said to be unimodular, if $|z| = 1$. If z_1 and z_2 are complex numbers such that $\frac{z_1 - 2z_2}{2 - z_1\bar{z}_2}$ is unimodular and z_2 is not unimodular. Then, the point z_1 lies on a **(2015 Main)**
 (a) straight line parallel to X-axis
 (b) straight line parallel to Y-axis
 (c) circle of radius 2
 (d) circle of radius $\sqrt{2}$
7. If z is a complex number such that $|z| \geq 2$, then the minimum value of $\left|z + \frac{1}{z}\right|$ **(2014 Main)**
 (a) is equal to 5/2
 (b) lies in the interval (1, 2)
 (c) is strictly greater than 5/2
 (d) is strictly greater than 3/2 but less than 5/2
8. Let complex numbers α and $1/\bar{\alpha}$ lies on circles $(x - x_0)^2 + (y - y_0)^2 = r^2$ and $(x - x_0)^2 + (y - y_0)^2 = 4r^2$, respectively. If $z_0 = x_0 + iy_0$ satisfies the equation $2|z_0|^2 = r^2 + 2$, then $|\alpha|$ is equal to **(2013 Adv.)**
 (a) $\frac{1}{\sqrt{2}}$ (b) $\frac{1}{2}$ (c) $\frac{1}{\sqrt{7}}$ (d) $\frac{1}{3}$
9. Let z be a complex number such that the imaginary part of z is non-zero and $a = z^2 + z + 1$ is real. Then, a cannot take the value **(2012)**
 (a) -1 (b) $\frac{1}{3}$ (c) $\frac{1}{2}$ (d) $\frac{3}{4}$
10. Let $z = x + iy$ be a complex number where, x and y are integers. Then, the area of the rectangle whose vertices are the root of the equation $z\bar{z}^3 + \bar{z}z^3 = 350$, is **(2009)**
 (a) 48 (b) 32
 (c) 40 (d) 80
11. If $|z| = 1$ and $z \neq \pm 1$, then all the values of $\frac{z}{1 - z^2}$ lie on **(2007, 3M)**
 (a) a line not passing through the origin
 (b) $|z| = \sqrt{2}$
 (c) the X-axis
 (d) the Y-axis
12. If $w = \alpha + i\beta$, where $\beta \neq 0$ and $z \neq 1$, satisfies the condition that $\left(\frac{w - \bar{w}z}{1 - z}\right)$ is purely real, then the set of values of z is **(2006, 3M)**
 (a) $|z| = 1, z \neq 2$ (b) $|z| = 1$ and $z \neq 1$
 (c) $z = \bar{z}$ (d) None of these
13. If $|z| = 1$ and $w = \frac{z - 1}{z + 1}$ (where, $z \neq -1$), then $\text{Re}(w)$ is **(2003, 1M)**
 (a) 0 (b) $\frac{1}{|z + 1|^2}$ (c) $\left|\frac{1}{z + 1}\right| \cdot \frac{1}{|z + 1|^2}$ (d) $\frac{\sqrt{2}}{|z + 1|^2}$
14. For all complex numbers z_1, z_2 satisfying $|z_1| = 12$ and $|z_2 - 3 - 4i| = 5$, the minimum value of $|z_1 - z_2|$ is **(2002, 1M)**
 (a) 0 (b) 2 (c) 7 (d) 17
15. If z_1, z_2 and z_3 are complex numbers such that $|z_1| = |z_2| = |z_3| = \left|\frac{1}{z_1} + \frac{1}{z_2} + \frac{1}{z_3}\right| = 1$, then $|z_1 + z_2 + z_3|$ is **(2000, 2M)**
 (a) equal to 1 (b) less than 1 (c) greater than 3 (d) equal to 3
16. For positive integers n_1, n_2 the value of expression $(1 + i)^{n_1} + (1 + i^3)^{n_1} + (1 + i^5)^{n_2} + (1 + i^7)^{n_2}$, here $i = \sqrt{-1}$ is a real number, if and only if **(1996, 2M)**
 (a) $n_1 = n_2 + 1$ (b) $n_1 = n_2 - 1$
 (c) $n_1 = n_2$ (d) $n_1 > 0, n_2 > 0$
17. The complex numbers $\sin x + i \cos 2x$ and $\cos x - i \sin 2x$ are conjugate to each other, for **(1988, 2M)**
 (a) $x = n\pi$ (b) $x = 0$ (c) $x = (n + 1/2)\pi$ (d) no value of x
18. The points z_1, z_2, z_3 and z_4 in the complex plane are the vertices of a parallelogram taken in order, if and only if **(1983, 1M)**
 (a) $z_1 + z_4 = z_2 + z_3$ (b) $z_1 + z_3 = z_2 + z_4$ (c) $z_1 + z_2 = z_3 + z_4$ (d) None of these
19. If $z = x + iy$ and $w = (1 - iz)/(z - i)$, then $|w| = 1$ implies that, in the complex plane **(1983, 1M)**
 (a) z lies on the imaginary axis (b) z lies on the real axis
 (c) z lies on the unit circle (d) None of these
20. The inequality $|z - 4| < |z - 2|$ represents the region given by **(1982, 2M)**
 (a) $\text{Re}(z) \geq 0$ (b) $\text{Re}(z) < 0$
 (c) $\text{Re}(z) > 0$ (d) None of these
21. If $z = \left(\frac{\sqrt{3}}{2} + \frac{i}{2}\right)^5 + \left(\frac{\sqrt{3}}{2} - \frac{i}{2}\right)^5$, then **(1982, 2M)**
 (a) $\text{Re}(z) = 0$ (b) $\text{Im}(z) = 0$
 (c) $\text{Re}(z) > 0, \text{Im}(z) > 0$ (d) $\text{Re}(z) > 0, \text{Im}(z) < 0$
22. The complex numbers $z = x + iy$ which satisfy the equation $\left|\frac{z - 5i}{z + 5i}\right| = 1$, lie on **(1981, 2M)**
 (a) the X-axis
 (b) the straight line $y = 5$
 (c) a circle passing through the origin
 (d) None of the above

4 Complex Numbers

35. If the expression $\frac{\left[\sin\left(\frac{x}{2}\right) + \cos\left(\frac{x}{2}\right) - i \tan(x) \right]}{\left[1 + 2i \sin\left(\frac{x}{2}\right) \right]}$ is real, then the set of all possible values of x is... (1987, 2M)

True/False

36. If three complex numbers are in AP. Then, they lie on a circle in the complex plane (1985 M)
37. If the complex numbers, z_1, z_2 and z_3 represent the vertices of an equilateral triangle such that $|z_1| = |z_2| = |z_3|$, then $z_1 + z_2 + z_3 = 0$. (1984, 1M)
38. For complex numbers $z_1 = x_1 + iy_1$ and $z_2 = x_2 + iy_2$, we write $z_1 \cap z_2$, if $x_1 \leq x_2$ and $y_1 \leq y_2$. Then, for all complex numbers z with $1 \cap z$, we have $\frac{1-z}{1+z} \cap 0$. (1981, 2M)

Analytical & Descriptive Questions

39. Find the centre and radius of the circle formed by all the points represented by $z = x + iy$ satisfying the relation $\left| \frac{z-\alpha}{z-\beta} \right| = k$ ($k \neq 1$), where α and β are the constant complex numbers given by $\alpha = \alpha_1 + i\alpha_2$, $\beta = \beta_1 + i\beta_2$. (2004, 2M)
40. Prove that there exists no complex number z such that $|z| < 1/3$ and $\sum_{r=1}^n a_r z^r = 1$, where $|a_r| < 2$. (2003, 2M)

41. If z_1 and z_2 are two complex numbers such that $|z_1| < 1 < |z_2|$, then prove that $\left| \frac{1-z_1\bar{z}_2}{z_1-z_2} \right| < 1$. (2003, 2M)
42. For complex numbers z and w , prove that $|z|^2 w - |w|^2 z = z - w$, if and only if $z = w$ or $z\bar{w} = 1$. (1999, 10M)
43. Find all non-zero complex numbers z satisfying $\bar{z} = iz^2$. (1996, 2M)
44. If $iz^3 + z^2 - z + i = 0$, then show that $|z| = 1$. (1995, 5M)
45. A relation R on the set of complex numbers is defined by $z_1 R z_2$, if and only if $\frac{z_1 - z_2}{z_1 + z_2}$ is real. Show that R is an equivalence relation. (1982, 2M)
46. Find the real values of x and y for which the following equation is satisfied $\frac{(1+i)x - 2i}{3+i} + \frac{(2-3i)y + i}{3-i} = i$. (1980, 2M)

47. Express $\frac{1}{(1 - \cos \theta) + 2i \sin \theta}$ in the form $A + iB$. (1979, 3M)
48. If $x + iy = \sqrt{\frac{a+ib}{c+id}}$, prove that $(x^2 + y^2)^2 = \frac{a^2 + b^2}{c^2 + d^2}$. (1978, 2M)

Integer & Numerical Answer Type Question

49. If z is any complex number satisfying $|z - 3 - 2i| \leq 2$, then the maximum value of $|2z - 6 + 5i|$ is (2011)

Topic 3 Argument of a Complex Number

Objective Questions I (Only one correct option)

1. If z_1, z_2 are complex numbers such that $\operatorname{Re}(z_1) = |z_1 - 1|$, $\operatorname{Re}(z_2) = |z_2 - 1|$ and $\arg(z_1 - z_2) = \frac{\pi}{6}$, then $\operatorname{Im}(z_1 + z_2)$ is equal to (2020 Main, 3 Sep II)
- (a) $\frac{\sqrt{3}}{2}$ (b) $\frac{1}{\sqrt{3}}$ (c) $\frac{2}{\sqrt{3}}$ (d) $2\sqrt{3}$
2. Let z_1 and z_2 be any two non-zero complex numbers such that $3|z_1| = 4|z_2|$. If $z = \frac{3z_1}{2z_2} + \frac{2z_2}{3z_1}$, then (2019 Main, 10 Jan I)
- (a) $|z| = \frac{1}{2}\sqrt{\frac{17}{2}}$ (b) $\operatorname{Im}(z) = 0$
- (c) $\operatorname{Re}(z) = 0$ (d) $|z| = \sqrt{\frac{5}{2}}$
3. If z is a complex number of unit modulus and argument θ , then $\arg\left(\frac{1+z}{1+\bar{z}}\right)$ is equal to (2013 Main)
- (a) $-\theta$ (b) $\frac{\pi}{2} - \theta$ (c) θ (d) $\pi - \theta$

4. If $\arg(z) < 0$, then $\arg(-z) - \arg(z)$ equals (2000, 2M)
- (a) π (b) $-\pi$
- (c) $-\pi/2$ (d) $\pi/2$
5. Let z and w be two complex numbers such that $|z| \leq 1$, $|w| \leq 1$ and $|z + iw| = |z - i\bar{w}| = 2$, then z equals (1995, 2M)
- (a) 1 or i (b) i or $-i$
- (c) 1 or -1 (d) i or -1
6. Let z and w be two non-zero complex numbers such that $|z| = |w|$ and $\arg(z) + \arg(w) = \pi$, then z equals (1995, 2M)
- (a) w (b) $-w$
- (c) \bar{w} (d) $-\bar{w}$
7. If z_1 and z_2 are two non-zero complex numbers such that $|z_1 + z_2| = |z_1| + |z_2|$, then $\arg(z_1) - \arg(z_2)$ is equal to (1987, 2M)
- (a) $-\pi$ (b) $-\frac{\pi}{2}$
- (c) 0 (d) $\frac{\pi}{2}$

8. If a, b, c and u, v, w are the complex numbers representing the vertices of two triangles such that $c = (1 - r)a + rb$ and $w = (1 - r)u + rv$, where r is a complex number, then the two triangles (1985, 2M)
- (a) have the same area (b) are similar
(c) are congruent (d) None of these

Objective Questions II

(One or more than one correct option)

9. For a non-zero complex number z , let $\arg(z)$ denote the principal argument with $-\pi < \arg(z) \leq \pi$. Then, which of the following statement(s) is (are) FALSE? (2018 Adv.)
- (a) $\arg(-1 - i) = \frac{\pi}{4}$, where $i = \sqrt{-1}$
- (b) The function $f: R \rightarrow (-\pi, \pi]$, defined by $f(t) = \arg(-1 + it)$ for all $t \in R$, is continuous at all points of R , where $i = \sqrt{-1}$.
- (c) For any two non-zero complex numbers z_1 and z_2 , $\arg\left(\frac{z_1}{z_2}\right) - \arg(z_1) + \arg(z_2)$ is an integer multiple of 2π .
- (d) For any three given distinct complex numbers z_1, z_2 and z_3 , the locus of the point z satisfying the condition $\arg\left(\frac{(z - z_1)(z_2 - z_3)}{(z - z_3)(z_2 - z_1)}\right) = \pi$, lies on a straight line.

Topic 4 Rotation of a Complex Number

Objective Questions I (Only one correct option)

1. Let S be the set of all complex numbers z satisfying $|z - 2 + i| \geq \sqrt{5}$. If the complex number z_0 is such that $\frac{1}{|z_0 - 1|}$ is the maximum of the set $\left\{\frac{1}{|z - 1|} : z \in S\right\}$, then the principal argument of $\frac{4 - z_0 - \bar{z}_0}{z_0 - \bar{z}_0 + 2i}$ is (2019 Adv.)
- (a) $\frac{\pi}{4}$ (b) $\frac{3\pi}{4}$ (c) $-\frac{\pi}{2}$ (d) $\frac{\pi}{2}$
2. Let $z = \left(\frac{\sqrt{3}}{2} + \frac{i}{2}\right)^5 + \left(\frac{\sqrt{3}}{2} - \frac{i}{2}\right)^5$. If $R(z)$ and $I(z)$ respectively denote the real and imaginary parts of z , then (2019 Main, 10 Jan II)
- (a) $R(z) > 0$ and $I(z) > 0$ (b) $I(z) = 0$
(c) $R(z) < 0$ and $I(z) > 0$ (d) $R(z) = -3$
3. A particle P starts from the point $z_0 = 1 + 2i$, where $i = \sqrt{-1}$. It moves first horizontally away from origin by 5 units and then vertically away from origin by 3 units to reach a point z_1 . From z_1 the particle moves $\sqrt{2}$ units in the direction of the vector $\hat{i} + \hat{j}$ and then it moves through an angle $\frac{\pi}{2}$ in anti-clockwise direction on a circle with centre at origin, to reach a point z_2 . The point z_2 is given by (2008, 3M)
- (a) $6 + 7i$ (b) $-7 + 6i$ (c) $7 + 6i$ (d) $-6 + 7i$

10. Let z_1 and z_2 be two distinct complex numbers and let $z = (1 - t)z_1 + tz_2$ for some real number t with $0 < t < 1$. If $\arg(w)$ denotes the principal argument of a non-zero complex number w , then (2010)
- (a) $|z - z_1| + |z - z_2| = |z_1 - z_2|$ (b) $\arg(z - z_1) = \arg(z - z_2)$
- (c) $\begin{vmatrix} z - z_1 & \bar{z} - \bar{z}_1 \\ z_2 - z_1 & \bar{z}_2 - \bar{z}_1 \end{vmatrix} = 0$ (d) $\arg(z - z_1) = \arg(z_2 - z_1)$

Match the Columns

11. Match the conditions/expressions in Column I with statement in Column II ($z \neq 0$ is a complex number)

Column I	Column II
A. $\operatorname{Re}(z) = 0$	p. $\operatorname{Re}(z^2) = 0$
B. $\arg(z) = \frac{\pi}{4}$	q. $\operatorname{Im}(z^2) = 0$
	r. $\operatorname{Re}(z^2) = \operatorname{Im}(z^2)$

Analytical & Descriptive Questions

12. $|z| \leq 1, |w| \leq 1$, then show that $|z - w|^2 \leq (|z| - |w|)^2 + (\arg z - \arg w)^2$ (1995, 5M)
13. Let $z_1 = 10 + 6i$ and $z_2 = 4 + 6i$. If z is any complex number such that the argument of $(z - z_1)/(z - z_2)$ is $\pi/4$, then prove that $|z - 7 - 9i| = 3\sqrt{2}$. (1991, 4M)

4. A man walks a distance of 3 units from the origin towards the North-East (N 45° E) direction. From there, he walks a distance of 4 units towards the North-West (N 45° W) direction to reach a point P . Then, the position of P in the Argand plane is (2007, 3M)
- (a) $3e^{i\pi/4} + 4i$
(b) $(3 - 4i)e^{i\pi/4}$
(c) $(4 + 3i)e^{i\pi/4}$
(d) $(3 + 4i)e^{i\pi/4}$

5. The shaded region, where $P = (-1, 0), Q = (-1 + \sqrt{2}, \sqrt{2}), R = (-1 + \sqrt{2}, -\sqrt{2}), S = (1, 0)$ is represented by (2005, 1M)

- (a) $|z + 1| > 2, |\arg(z + 1)| < \frac{\pi}{4}$
(b) $|z + 1| < 2, |\arg(z + 1)| < \frac{\pi}{2}$
(c) $|z + 1| > 2, |\arg(z + 1)| > \frac{\pi}{4}$
(d) $|z - 1| < 2, |\arg(z + 1)| > \frac{\pi}{2}$

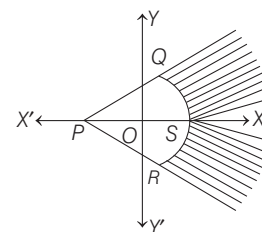

6. If $0 < \alpha < \frac{\pi}{2}$ is a fixed angle. If $P = (\cos \theta, \sin \theta)$ and $Q = \{\cos(\alpha - \theta), \sin(\alpha - \theta)\}$, then Q is obtained from P by (2002, 2M)

- (a) clockwise rotation around origin through an angle α
(b) anti-clockwise rotation around origin through an angle α
(c) reflection in the line through origin with slope $\tan \alpha$
(d) reflection in the line through origin with slope $\tan \frac{\alpha}{2}$

6 Complex Numbers

7. The complex numbers z_1, z_2 and z_3 satisfying $\frac{z_1 - z_3}{z_2 - z_3} = \frac{1 - i\sqrt{3}}{2}$ are the vertices of a triangle which is (2001, 1M)
- (a) of area zero (b) right angled isosceles
(c) equilateral (d) obtuse angled isosceles

Objective Questions II

(One or more than one correct option)

8. Let $a, b \in \mathbb{R}$ and $a^2 + b^2 \neq 0$.
Suppose $S = \left\{ z \in \mathbb{C} : z = \frac{1}{a + i bt}, t \in \mathbb{R}, t \neq 0 \right\}$, where $i = \sqrt{-1}$. If $z = x + iy$ and $z \in S$, then (x, y) lies on (2016 Adv.)
- (a) the circle with radius $\frac{1}{2a}$ and centre $\left(\frac{1}{2a}, 0\right)$ for $a > 0, b \neq 0$
(b) the circle with radius $-\frac{1}{2a}$ and centre $\left(-\frac{1}{2a}, 0\right)$ for $a < 0, b \neq 0$
(c) the X-axis for $a \neq 0, b = 0$
(d) the Y-axis for $a = 0, b \neq 0$
9. Let $W = \frac{\sqrt{3} + i}{2}$ and $P = \{W^n : n = 1, 2, 3, \dots\}$.
Further $H_1 = \left\{ z \in \mathbb{C} : \operatorname{Re}(z) > \frac{1}{2} \right\}$
and $H_2 = \left\{ z \in \mathbb{C} : \operatorname{Re}(z) < \frac{-1}{2} \right\}$, where C is the set of all complex numbers. If $z_1 \in P \cap H_1, z_2 \in P \cap H_2$ and O represents the origin, then $\angle z_1 O z_2$ is equal to (2013 JEE Adv.)
- (a) $\frac{\pi}{2}$ (b) $\frac{\pi}{6}$ (c) $\frac{2\pi}{3}$ (d) $\frac{5\pi}{6}$

Fill in the Blanks

10. Suppose z_1, z_2, z_3 are the vertices of an equilateral triangle inscribed in the circle $|z| = 2$. If $z_1 = 1 + i\sqrt{3}$, then $z_2 = \dots, z_3 = \dots$. (1994, 2M)
11. $ABCD$ is a rhombus. Its diagonals AC and BD intersect at the point M and satisfy $BD = 2AC$. If the points D and M represent the complex numbers $1 + i$ and $2 - i$ respectively, then A represents the complex number ...or... (1993, 2M)
12. If a and b are real numbers between 0 and 1 such that the points $z_1 = a + i, z_2 = 1 + bi$ and $z_3 = 0$ form an equilateral triangle, then $a = \dots$ and $b = \dots$. (1990, 2M)

Analytical & Descriptive Questions

13. If one of the vertices of the square circumscribing the circle $|z - 1| = \sqrt{2}$ is $2 + \sqrt{3}i$. Find the other vertices of square. (2005, 4M)
14. Let $\bar{b}z + b\bar{z} = c, b \neq 0$, be a line in the complex plane, where \bar{b} is the complex conjugate of b . If a point z_1 is the reflection of the point z_2 through the line, then show that $c = \bar{z}_1 b + z_2 \bar{b}$. (1997C, 5M)
15. Let z_1 and z_2 be the roots of the equation $z^2 + pz + q = 0$, where the coefficients p and q may be complex numbers. Let A and B represent z_1 and z_2 in the complex plane. If $\angle AOB = \alpha \neq 0$ and $OA = OB$, where O is the origin prove that $p^2 = 4q \cos^2\left(\frac{\alpha}{2}\right)$. (1997, 5M)
16. Complex numbers z_1, z_2, z_3 are the vertices A, B, C respectively of an isosceles right angled triangle with right angle at C . Show that $(z_1 - z_2)^2 = 2(z_1 - z_3)(z_3 - z_2)$. (1986, 2 $\frac{1}{2}$ M)
17. Show that the area of the triangle on the argand diagram formed by the complex number z, iz and $z + iz$ is $\frac{1}{2}|z|^2$. (1986, 2 $\frac{1}{2}$ M)
18. Prove that the complex numbers z_1, z_2 and the origin form an equilateral triangle only if $z_1^2 + z_2^2 - z_1 z_2 = 0$. (1983, 2M)
19. Let the complex numbers z_1, z_2 and z_3 be the vertices of an equilateral triangle. Let z_0 be the circumcentre of the triangle. Then, prove that $z_1^2 + z_2^2 + z_3^2 = 3z_0^2$. (1981, 4M)

Integer & Numerical Answer Type Questions

20. For a complex number z , let $\operatorname{Re}(z)$ denote the real part of z . Let S be the set of all complex numbers z satisfying $z^4 - |z|^4 = 4iz^2$, where $i = \sqrt{-1}$. Then the minimum possible value of $|z_1 - z_2|^2$, where $z_1, z_2 \in S$ with $\operatorname{Re}(z_1) > 0$ and $\operatorname{Re}(z_2) < 0$ is (2020 Adv.)
21. For any integer k , let $\alpha_k = \cos\left(\frac{k\pi}{7}\right) + i \sin\left(\frac{k\pi}{7}\right)$, where $i = \sqrt{-1}$. The value of the expression $\frac{\sum_{k=1}^{12} |\alpha_{k+1} - \alpha_k|}{\sum_{k=1}^3 |\alpha_{4k-1} - \alpha_{4k-2}|}$ is (2016 Adv.)

Topic 5 De-Moivre's Theorem, Cube Roots and n th Roots of Unity

Objective Questions I (Only one correct option)

1. The value of $\left(\frac{1 + \sin \frac{2\pi}{9} + i \cos \frac{2\pi}{9}}{1 + \sin \frac{2\pi}{9} - i \cos \frac{2\pi}{9}}\right)^3$ is

[2020 Main, 2 Sep I]

- (a) $-\frac{1}{2}(\sqrt{3} - i)$ (b) $-\frac{1}{2}(1 - i\sqrt{3})$
 (c) $\frac{1}{2}(\sqrt{3} - i)$ (d) $\frac{1}{2}(1 - i\sqrt{3})$

2. If z and w are two complex numbers such that $|zw| = 1$ and $\arg(z) - \arg(w) = \frac{\pi}{2}$, then

(2019 Main, 10 April II)

- (a) $\bar{z}w = -i$ (b) $z\bar{w} = \frac{1-i}{\sqrt{2}}$
 (c) $\bar{z}w = i$ (d) $z\bar{w} = \frac{-1+i}{\sqrt{2}}$

3. If $z = \frac{\sqrt{3}}{2} + \frac{i}{2}$ ($i = \sqrt{-1}$), then $(1 + iz + z^5 + iz^8)^9$ is equal to

(2019 Main, 8 April II)

- (a) 1 (b) $(-1 + 2i)^9$ (c) -1 (d) 0

4. Let z_0 be a root of the quadratic equation, $x^2 + x + 1 = 0$. If $z = 3 + 6iz_0^{81} - 3iz_0^{93}$, then $\arg z$ is equal to

(2019 Main, 9 Jan II)

- (a) $\frac{\pi}{4}$ (b) $\frac{\pi}{6}$ (c) 0 (d) $\frac{\pi}{3}$

5. Let $z = \cos \theta + i \sin \theta$. Then, the value of $\sum_{m=1}^{15} \operatorname{Im}(z^{2m-1})$ at

$\theta = 2^\circ$ is

(2009)

- (a) $\frac{1}{\sin 2^\circ}$ (b) $\frac{1}{3 \sin 2^\circ}$
 (c) $\frac{1}{2 \sin 2^\circ}$ (d) $\frac{1}{4 \sin 2^\circ}$

6. The minimum value of $|a + b\omega + c\omega^2|$, where a, b and c are all not equal integers and $\omega (\neq 1)$ is a cube root of unity, is

(2005, 1M)

- (a) $\sqrt{3}$ (b) $\frac{1}{2}$ (c) 1 (d) 0

7. If $\omega (\neq 1)$ be a cube root of unity and $(1 + \omega^2)^n = (1 + \omega^4)^n$, then the least positive value of n is

(2004, 1M)

- (a) 2 (b) 3 (c) 5 (d) 6

8. Let $\omega = -\frac{1}{2} + i\frac{\sqrt{3}}{2}$, then value of the determinant

$$\begin{vmatrix} 1 & 1 & 1 \\ 1 & -1 - \omega^2 & \omega^2 \\ 1 & \omega^2 & \omega \end{vmatrix}$$
 is

(2002, 1M)

- (a) 3ω (b) $3\omega(\omega - 1)$ (c) $3\omega^2$ (d) $3\omega(1 - \omega)$

9. Let z_1 and z_2 be n th roots of unity which subtend a right angled at the origin, then n must be of the form (where, k is an integer)

(2001, 1M)

- (a) $4k + 1$ (b) $4k + 2$ (c) $4k + 3$ (d) $4k$

10. If $i = \sqrt{-1}$, then $4 + 5\left(-\frac{1}{2} + \frac{i\sqrt{3}}{2}\right)^{334} + 3\left(-\frac{1}{2} + \frac{i\sqrt{3}}{2}\right)^{365}$

is equal to

(1999, 2M)

- (a) $1 - i\sqrt{3}$ (b) $-1 + i\sqrt{3}$ (c) $i\sqrt{3}$ (d) $-i\sqrt{3}$

11. If ω is an imaginary cube root of unity, then $(1 + \omega - \omega^2)^7$ is equal to

(1998, 2M)

- (a) 128ω (b) -128ω (c) $128\omega^2$ (d) $-128\omega^2$

12. If $\omega (\neq 1)$ is a cube root of unity and $(1 + \omega)^7 = A + B\omega$, then A and B are respectively

(1995, 2M)

- (a) 0, 1 (b) 1, 1 (c) 1, 0 (d) $-1, 1$

13. The value of $\sum_{k=1}^6 \left(\sin \frac{2\pi k}{7} - i \cos \frac{2\pi k}{7}\right)$ is

(1998, 2M)

- (a) -1 (b) 0 (c) $-i$ (d) i

Match the Columns

14. Let $z_k = \cos\left(\frac{2k\pi}{10}\right) + i \sin\left(\frac{2k\pi}{10}\right); k = 1, 2, \dots, 9$.

	Column I	Column II
P.	For each z_k , there exists a z_j such that $z_k \cdot z_j = 1$	(i) True
Q.	There exists a $k \in \{1, 2, \dots, 9\}$ such that $z_1 \cdot z = z_k$ has no solution z in the set of complex numbers	(ii) False
R.	$\frac{ 1 - z_1 1 - z_2 \dots 1 - z_9 }{10}$ equal	(iii) 1
S.	$1 - \sum_{k=1}^9 \cos\left(\frac{2k\pi}{10}\right)$ equals	(iv) 2

(2011)

Codes

	P	Q	R	S
(a)	(i)	(ii)	(iv)	(iii)
(b)	(ii)	(i)	(iii)	(iv)
(c)	(i)	(ii)	(iii)	(iv)
(d)	(ii)	(i)	(iv)	(iii)

Fill in the Blanks

15. Let ω be the complex number $\cos \frac{2\pi}{3} + i \sin \frac{2\pi}{3}$. Then the number of distinct complex number z satisfying

$$\begin{vmatrix} z+1 & \omega & \omega^2 \\ \omega & z+\omega^2 & 1 \\ \omega^2 & 1 & z+\omega \end{vmatrix} = 0$$
 is equal to ...

(2010)

8 Complex Numbers

16. The value of the expression
 $1(2-\omega)(2-\omega^2) + 2(3-\omega)(3-\omega^2) + \dots$
 $+ (n-1) \cdot (n-\omega)(n-\omega^2)$,
 where, ω is an imaginary cube root of unity, is....
 (1996, 2M)

True/False

17. The cube roots of unity when represented on Argand diagram form the vertices of an equilateral triangle.
 (1988, 1M)

Analytical & Descriptive Questions

18. Let a complex number $\alpha, \alpha \neq 1$, be a root of the equation
 $z^{p+q} - z^p - z^q + 1 = 0$
 where, p and q are distinct primes. Show that either
 $1 + \alpha + \alpha^2 + \dots + \alpha^{p-1} = 0$
 or $1 + \alpha + \alpha^2 + \dots + \alpha^{q-1} = 0$
 but not both together. (2002, 5M)

19. If $1, \alpha_1, \alpha_2, \dots, \alpha_{n-1}$ are the n roots of unity, then show that $(1 - \alpha_1)(1 - \alpha_2)(1 - \alpha_3) \dots (1 - \alpha_{n-1}) = n$ (1984, 2M)
 20. It is given that n is an odd integer greater than 3, but n is not a multiple of 3. Prove that $x^3 + x^2 + x$ is a factor of $(x+1)^n - x^n - 1$. (1980, 3M)
 21. If $x = a + b, y = a\alpha + b\beta, z = a\beta + b\alpha$, where α, β are complex cube roots of unity, then show that $xyz = a^3 + b^3$. (1979, 3M)

Integer & Numerical Answer Type Questions

22. Let $\omega \neq 1$ be a cube root of unity. Then the minimum of the set $\{|a + b\omega + c\omega^2|^2 : a, b, c \text{ distinct non-zero integers}\}$ equals (2019 Adv.)
 23. Let $\omega = e^{i\pi/3}$ and a, b, c, x, y, z be non-zero complex numbers such that $a + b + c = x, a + b\omega + c\omega^2 = y, a + b\omega^2 + c\omega = z$.
 Then, the value of $\frac{|x|^2 + |y|^2 + |z|^2}{|a|^2 + |b|^2 + |c|^2}$ is (2011)

Answers

Topic 1

1. (c) 2. (c) 3. (b) 4. (a)
 5. (d) 6. (d) 7. (d) 8. (b)
 9. (d) 10. (b, d)

Topic 2

1. (b) 2. (b) 3. (d) 4. (d)
 5. (b) 6. (c) 7. (b) 8. (c)
 9. (d) 10. (a) 11. (d) 12. (b)
 13. (a) 14. (b) 15. (a) 16. (d)
 17. (d) 18. (b) 19. (b) 20. (d)
 21. (b) 22. (a) 23. (b,c) 24. (a, c, d)
 25. (a,d) 26. (a, b, c) 27. (c) 28. (b)
 29. (d) 30. (c) 31. (b)
 32. $A \rightarrow q, r; B \rightarrow p; C \rightarrow p, s, t; D \rightarrow q, r, s, t$
 33. ω^2 34. $(a^2 + b^2)(|z_1|^2 + |z_2|^2)$
 35. $x = 2n\pi + 2\alpha, \alpha = \tan^{-1}k$, where $k \in (1, 2)$ or $x = 2n\pi$
 36. False 37. True
 38. True

39. Centre = $\frac{\alpha - k^2\beta}{1 - k^2}$, Radius = $\left| \frac{k(\alpha - \beta)}{1 - k^2} \right|$

43. $\left[z = i, \pm \frac{\sqrt{3}}{2} - \frac{i}{2} \right]$

46. $(x = 3 \text{ and } y = -1)$

47. $A + iB = \frac{1}{2\left(1 + 3 \cos^2 \frac{\theta}{2}\right)} - i \frac{\cot(\theta/2)}{1 + 3 \cos^2(\theta/2)}$ 49. 5

Topic 3

1. (d) 2. (*) 3. (c) 4. (a)
 5. (c) 6. (d) 7. (c) 8. (b)
 9. (a, b, d) 10. (a, c, d) 11. $A \rightarrow q; B \rightarrow p$

Topic 4

1. (c) 2. (b) 3. (d) 4. (d)
 5. (a) 6. (d) 7. (c) 8. (a,c,d)
 9. (c, d) 10. $z_2 = -2, z_3 = 1 - i\sqrt{3}$
 11. $3 - \frac{i}{2}$ or $1 - \frac{3i}{2}$ 12. $a = b = 2 \pm \sqrt{3}$
 13. $z_2 = -\sqrt{3}i, z_3 = (1 - \sqrt{3}) + i$ and $z_4 = (1 + \sqrt{3}) - i$
 20. (8) 21. (4)

Topic 5

1. (a) 2. (a) 3. (c) 3. (a)
 5. (d) 6. (c) 7. (b) 8. (b)
 9. (d) 10. (c) 11. (d) 12. (b)
 13. (d) 14. (c) 15. (1)
 16. $\left(\frac{n(n+1)}{2}\right)^2 - n$ 17. True 22. (3)
 23. (3)

Hints & Solutions

Topic 1 Complex Number in Iota Form

1. Let $z = x + 10i$, as $\text{Im}(z) = 10$ (given).

Since z satisfies,

$$\frac{2z - n}{2z + n} = 2i - 1, n \in \mathbb{N},$$

$$\begin{aligned} \therefore (2x + 20i - n) &= (2i - 1)(2x + 20i + n) \\ \Rightarrow (2x - n) + 20i &= (-2x - n - 40) + (4x + 2n - 20)i \end{aligned}$$

On comparing real and imaginary parts, we get

$$\begin{aligned} 2x - n &= -2x - n - 40 \text{ and } 20 = 4x + 2n - 20 \\ \Rightarrow 4x &= -40 \text{ and } 4x + 2n = 40 \\ \Rightarrow x &= -10 \text{ and } -40 + 2n = 40 \Rightarrow n = 40 \\ \text{So, } n &= 40 \text{ and } x = \text{Re}(z) = -10 \end{aligned}$$

2. Let $x + iy = \frac{\alpha + i}{\alpha - i}$

$$\Rightarrow x + iy = \frac{(\alpha + i)^2}{\alpha^2 + 1} = \frac{(\alpha^2 - 1) + (2\alpha)i}{\alpha^2 + 1} = \frac{\alpha^2 - 1}{\alpha^2 + 1} + \left(\frac{2\alpha}{\alpha^2 + 1}\right)i$$

On comparing real and imaginary parts, we get

$$x = \frac{\alpha^2 - 1}{\alpha^2 + 1} \text{ and } y = \frac{2\alpha}{\alpha^2 + 1}$$

$$\text{Now, } x^2 + y^2 = \left(\frac{\alpha^2 - 1}{\alpha^2 + 1}\right)^2 + \left(\frac{2\alpha}{\alpha^2 + 1}\right)^2$$

$$= \frac{\alpha^4 + 1 - 2\alpha^2 + 4\alpha^2}{(\alpha^2 + 1)^2} = \frac{(\alpha^2 + 1)^2}{(\alpha^2 + 1)^2} = 1$$

$$\Rightarrow x^2 + y^2 = 1$$

Which is an equation of circle with centre $(0, 0)$ and radius 1 unit.

So, $S = \left\{ \frac{\alpha + i}{\alpha - i}; \alpha \in \mathbb{R} \right\}$ lies on a circle with radius 1.

3. Given complex number

$$\omega = \frac{5 + 3z}{5(1 - z)}$$

$$\begin{aligned} \Rightarrow 5\omega - 5\omega z &= 5 + 3z \\ \Rightarrow (3 + 5\omega)z &= 5\omega - 5 \\ \Rightarrow |3 + 5\omega||z| &= |5\omega - 5| \quad \dots(i) \\ &[\text{applying modulus both sides and } |z_1 z_2| = |z_1||z_2|] \\ \therefore |z| &< 1 \end{aligned}$$

$$\therefore |3 + 5\omega| > |5\omega - 5| \quad [\text{from Eq. (i)}]$$

$$\Rightarrow \left| \omega + \frac{3}{5} \right| > |\omega - 1|$$

$$\text{Let } \omega = x + iy, \text{ then } \left(x + \frac{3}{5}\right)^2 + y^2 > (x - 1)^2 + y^2$$

$$\Rightarrow x^2 + \frac{9}{25} + \frac{6}{5}x > x^2 + 1 - 2x$$

$$\Rightarrow \frac{16x}{5} > \frac{16}{25} \Rightarrow x > \frac{1}{5} \Rightarrow 5x > 1$$

$$\Rightarrow 5 \text{Re}(\omega) > 1$$

4. We have, $\frac{x + iy}{27} = \left(-2 - \frac{1}{3}i\right)^3 = \left[\frac{-1}{3}(6 + i)\right]^3$

$$\begin{aligned} \Rightarrow \frac{x + iy}{27} &= -\frac{1}{27}(216 + 108i + 18i^2 + i^3) \\ &= -\frac{1}{27}(198 + 107i) \end{aligned}$$

$$[\because (a + b)^3 = a^3 + b^3 + 3a^2b + 3ab^2, i^2 = -1, i^3 = -i]$$

On equating real and imaginary part, we get

$$\begin{aligned} x &= -198 \text{ and } y = -107 \\ \Rightarrow y - x &= -107 + 198 = 91 \end{aligned}$$

5. Let $z = \left(\frac{3 + 2i \sin \theta}{1 - 2i \sin \theta}\right) \times \left(\frac{1 + 2i \sin \theta}{1 + 2i \sin \theta}\right)$

(rationalising the denominator)

$$= \frac{3 - 4 \sin^2 \theta + 8i \sin \theta}{1 + 4 \sin^2 \theta}$$

$$[\because a^2 - b^2 = (a + b)(a - b) \text{ and } i^2 = -1]$$

$$= \left(\frac{3 - 4 \sin^2 \theta}{1 + 4 \sin^2 \theta}\right) + \left(\frac{8 \sin \theta}{1 + 4 \sin^2 \theta}\right)i$$

As z is purely imaginary, so real part of $z = 0$

$$\therefore \frac{3 - 4 \sin^2 \theta}{1 + 4 \sin^2 \theta} = 0 \Rightarrow 3 - 4 \sin^2 \theta = 0$$

$$\Rightarrow \sin^2 \theta = \frac{3}{4}$$

$$\Rightarrow \sin \theta = \pm \frac{\sqrt{3}}{2}$$

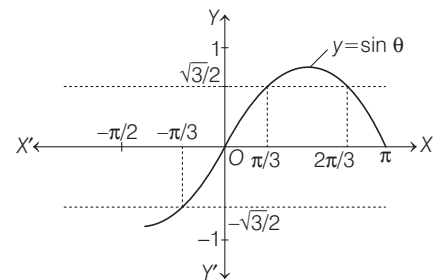

$$\Rightarrow \theta \in \left\{ -\frac{\pi}{3}, \frac{\pi}{3}, \frac{2\pi}{3} \right\}$$

$$\text{Sum of values of } \theta = \frac{2\pi}{3}$$

6. Let $z = \frac{2 + 3i \sin \theta}{1 - 2i \sin \theta}$ is purely imaginary. Then, we have

$$\text{Re}(z) = 0$$

$$\text{Now, consider } z = \frac{2 + 3i \sin \theta}{1 - 2i \sin \theta}$$

$$= \frac{(2 + 3i \sin \theta)(1 + 2i \sin \theta)}{(1 - 2i \sin \theta)(1 + 2i \sin \theta)}$$

$$= \frac{2 + 4i \sin \theta + 3i \sin \theta + 6i^2 \sin^2 \theta}{1^2 - (2i \sin \theta)^2}$$

10 Complex Numbers

$$= \frac{2 + 7i \sin \theta - 6 \sin^2 \theta}{1 + 4 \sin^2 \theta}$$

$$= \frac{2 - 6 \sin^2 \theta}{1 + 4 \sin^2 \theta} + i \frac{7 \sin \theta}{1 + 4 \sin^2 \theta}$$

$$\therefore \operatorname{Re}(z) = 0$$

$$\therefore \frac{2 - 6 \sin^2 \theta}{1 + 4 \sin^2 \theta} = 0 \Rightarrow 2 = 6 \sin^2 \theta$$

$$\Rightarrow \sin^2 \theta = \frac{1}{3}$$

$$\Rightarrow \sin \theta = \pm \frac{1}{\sqrt{3}}$$

$$\Rightarrow \theta = \sin^{-1} \left(\pm \frac{1}{\sqrt{3}} \right) = \pm \sin^{-1} \left(\frac{1}{\sqrt{3}} \right)$$

7. Given, $\begin{vmatrix} 6i & -3i & 1 \\ 4 & 3i & -1 \\ 20 & 3 & i \end{vmatrix} = x + iy$

$$\Rightarrow -3i \begin{vmatrix} 6i & 1 & 1 \\ 4 & -1 & -1 \\ 20 & i & i \end{vmatrix} = x + iy$$

$$\Rightarrow x + iy = 0 \quad [\because C_2 \text{ and } C_3 \text{ are identical}]$$

$$\Rightarrow x = 0, y = 0$$

8. $\sum_{n=1}^{13} (i^n + i^{n+1}) = \sum_{n=1}^{13} i^n (1 + i) = (1 + i) \sum_{n=1}^{13} i^n$

$$= (1 + i) (i + i^2 + i^3 + \dots + i^{13}) = (1 + i) \left[\frac{i - (1 - i^{13})}{1 - i} \right]$$

$$= (1 + i) \left[\frac{i(1 - i)}{1 - i} \right] = (1 + i)i = i - 1$$

Alternate Solution

Since, sum of any four consecutive powers of i is zero.

$$\therefore \sum_{n=1}^{13} (i^n + i^{n+1}) = (i + i^2 + \dots + i^{13})$$

$$+ (i^2 + i^3 + \dots + i^{14}) = i + i^2 = i - 1$$

9. Since, $\left(\frac{1+i}{1-i} \right)^n = 1 \Rightarrow \left(\frac{1+i}{1-i} \times \frac{1+i}{1+i} \right)^n = 1$

$$\Rightarrow \left(\frac{2i}{2} \right)^n = 1$$

$$\Rightarrow i^n = 1$$

The smallest positive integer n for which $i^n = 1$ is 4.

$$\therefore n = 4$$

10. $\frac{az + b}{z + 1} = \frac{ax + b + ai y}{(x + 1) + iy} = \frac{(ax + b + ai y)((x + 1) - iy)}{(x + 1)^2 + y^2}$

$$\therefore \operatorname{Im} \left(\frac{az + b}{z + 1} \right) = \frac{-(ax + b)y + ay(x + 1)}{(x + 1)^2 + y^2}$$

$$\Rightarrow \frac{(a - b)y}{(x + 1)^2 + y^2} = y$$

$$\therefore a - b = 1$$

$$\therefore (x + 1)^2 + y^2 = 1$$

$$\therefore x = -1 \pm \sqrt{1 - y^2}$$

Topic 2 Conjugate and Modulus of Complex Number

1. Let the complex number $z = x + iy$

$$\text{Also given, } |z - i| = |z - 1|$$

$$\Rightarrow |x + iy - i| = |x + iy - 1|$$

$$\Rightarrow \sqrt{x^2 + (y - 1)^2} = \sqrt{(x - 1)^2 + y^2}$$

$$[\because |z| = \sqrt{(\operatorname{Re}(z))^2 + (\operatorname{Im}(z))^2}]$$

On squaring both sides, we get

$$x^2 + y^2 - 2y + 1 = x^2 + y^2 - 2x + 1$$

$\Rightarrow y = x$, which represents a line passing through the origin with slope 1.

2. The given complex number $z = \frac{(1 + i)^2}{a - i}$

$$= \frac{(1 - 1 + 2i)(a + i)}{a^2 + 1} \quad [\because i^2 = -1]$$

$$= \frac{2i(a + i)}{a^2 + 1} = \frac{-2 + 2ai}{a^2 + 1} \quad \dots(i)$$

$$\therefore |z| = \sqrt{2/5} \quad [\text{given}]$$

$$\Rightarrow \sqrt{\frac{4 + 4a^2}{(a^2 + 1)^2}} = \sqrt{\frac{2}{5}} \Rightarrow \frac{2}{\sqrt{1 + a^2}} = \sqrt{\frac{2}{5}}$$

$$\Rightarrow \frac{4}{1 + a^2} = \frac{2}{5} \Rightarrow a^2 + 1 = 10 \Rightarrow a^2 = 9 \Rightarrow a = 3 \quad [\because a > 0]$$

$$\therefore z = \frac{-2 + 6i}{10} \quad [\text{From Eq. (i)}]$$

$$\text{So, } \bar{z} = \left(\frac{-2 + 6i}{10} \right) = \left(-\frac{1}{5} + \frac{3}{5}i \right) \Rightarrow \bar{z} = -\frac{1}{5} - \frac{3}{5}i$$

$$[\because \text{if } z = x + iy, \text{ then } \bar{z} = x - iy]$$

3. Clearly $|z_1| = 9$, represents a circle having centre $C_1(0, 0)$ and radius $r_1 = 9$.

and $|z_2 - 3 - 4i| = 4$ represents a circle having centre $C_2(3, 4)$ and radius $r_2 = 4$.

The minimum value of $|z_1 - z_2|$ is equals to minimum distance between circles $|z_1| = 9$ and $|z_2 - 3 - 4i| = 4$.

$$\therefore C_1C_2 = \sqrt{(3 - 0)^2 + (4 - 0)^2} = \sqrt{9 + 16} = \sqrt{25} = 5$$

$$\text{and } |r_1 - r_2| = |9 - 4| = 5 \Rightarrow C_1C_2 = |r_1 - r_2|$$

\therefore Circles touches each other internally.

$$\text{Hence, } |z_1 - z_2|_{\min} = 0$$

4. Since, the complex number $\frac{z - \alpha}{z + \alpha}$ ($\alpha \in R$) is purely

imaginary number, therefore

$$\frac{z - \alpha}{z + \alpha} + \frac{\bar{z} - \alpha}{\bar{z} + \alpha} = 0 \quad [\because \alpha \in R]$$

$$\Rightarrow z\bar{z} - \alpha\bar{z} + \alpha z - \alpha^2 + z\bar{z} - \alpha z + \alpha\bar{z} - \alpha^2 = 0$$

$$\Rightarrow 2|z|^2 - 2\alpha^2 = 0 \quad [\because z\bar{z} = |z|^2]$$

$$\Rightarrow \alpha^2 = |z|^2 = 4 \quad [|z| = 2 \text{ given}]$$

$$\Rightarrow \alpha = \pm 2$$

5. We have, $|z| + z = 3 + i$

Let $z = x + iy$
 $\therefore \sqrt{x^2 + y^2} + x + iy = 3 + i$
 $\Rightarrow (x + \sqrt{x^2 + y^2}) + iy = 3 + i$
 $\Rightarrow x + \sqrt{x^2 + y^2} = 3$ and $y = 1$
 Now, $\sqrt{x^2 + 1} = 3 - x$
 $\Rightarrow x^2 + 1 = 9 - 6x + x^2$
 $\Rightarrow 6x = 8 \Rightarrow x = \frac{4}{3}$
 $\therefore z = \frac{4}{3} + i$
 $\Rightarrow |z| = \sqrt{\frac{16}{9} + 1} = \sqrt{\frac{25}{9}} \Rightarrow |z| = \frac{5}{3}$

6. **PLAN** If z is unimodular, then $|z| = 1$. Also, use property of modulus i.e. $z\bar{z} = |z|^2$

Given, z_2 is not unimodular i.e. $|z_2| \neq 1$
 and $\frac{z_1 - 2z_2}{2 - z_1\bar{z}_2}$ is unimodular.
 $\Rightarrow \left| \frac{z_1 - 2z_2}{2 - z_1\bar{z}_2} \right| = 1 \Rightarrow |z_1 - 2z_2|^2 = |2 - z_1\bar{z}_2|^2$
 $\Rightarrow (z_1 - 2z_2)(\bar{z}_1 - 2\bar{z}_2) = (2 - z_1\bar{z}_2)(2 - \bar{z}_1z_2)$ [$z\bar{z} = |z|^2$]
 $\Rightarrow |z_1|^2 + 4|z_2|^2 - 2\bar{z}_1z_2 - 2z_1\bar{z}_2 = 4 - 2z_1\bar{z}_2 - 2\bar{z}_1z_2$
 $= 4 + |z_1|^2|z_2|^2 - 2\bar{z}_1z_2 - 2z_1\bar{z}_2 \Rightarrow (|z_2|^2 - 1)(|z_1|^2 - 4) = 0$
 $\therefore |z_2| \neq 1$
 $\therefore |z_1| = 2$
 Let $z_1 = x + iy \Rightarrow x^2 + y^2 = (2)^2$
 \therefore Point z_1 lies on a circle of radius 2.

7. $|z| \geq 2$ is the region on or outside circle whose centre is $(0, 0)$ and radius is 2.

Minimum $\left| z + \frac{1}{2} \right|$ is distance of z , which lie on circle $|z| = 2$ from $(-1/2, 0)$.

\therefore Minimum $\left| z + \frac{1}{2} \right| =$ Distance of $\left(-\frac{1}{2}, 0 \right)$ from $(-2, 0)$
 $= \sqrt{\left(-2 + \frac{1}{2} \right)^2 + 0} = \frac{3}{2} = \sqrt{\left(\frac{-1}{2} + 2 \right)^2 + 0} = \frac{3}{2}$

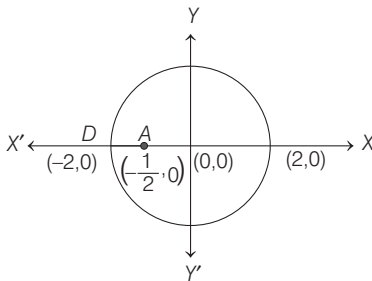

Geometrically $\text{Min} \left| z + \frac{1}{2} \right| = AD$

Hence, minimum value of $\left| z + \frac{1}{2} \right|$ lies in the interval $(1, 2)$.

8. **PLAN** Intersection of circles, the basic concept is to solve the equations simultaneously and using properties of modulus of complex numbers.

Formula used $|z|^2 = z \cdot \bar{z}$
 and $|z_1 - z_2|^2 = (z_1 - z_2)(\bar{z}_1 - \bar{z}_2)$
 $= |z_1|^2 - z_1\bar{z}_2 - z_2\bar{z}_1 + |z_2|^2$
 Here, $(x - x_0)^2 + (y - y_0)^2 = r^2$
 and $(x - x_0)^2 + (y - y_0)^2 = 4r^2$ can be written as,
 $|z - z_0|^2 = r^2$ and $|z - z_0|^2 = 4r^2$

Since, α and $\frac{1}{\alpha}$ lies on first and second respectively.

$\therefore | \alpha - z_0 |^2 = r^2$ and $\left| \frac{1}{\alpha} - z_0 \right|^2 = 4r^2$
 $\Rightarrow (\alpha - z_0)(\bar{\alpha} - \bar{z}_0) = r^2$
 $\Rightarrow |\alpha|^2 - z_0\bar{\alpha} - \bar{z}_0\alpha + |z_0|^2 = r^2$... (i)

and $\left| \frac{1}{\alpha} - z_0 \right|^2 = 4r^2$

$\Rightarrow \left(\frac{1}{\alpha} - z_0 \right) \left(\frac{1}{\alpha} - \bar{z}_0 \right) = 4r^2$

$\Rightarrow \frac{1}{|\alpha|^2} - \frac{z_0}{\alpha} - \frac{\bar{z}_0}{\bar{\alpha}} + |z_0|^2 = 4r^2$

Since, $|\alpha|^2 = \alpha \cdot \bar{\alpha}$

$\Rightarrow \frac{1}{|\alpha|^2} - \frac{z_0 \cdot \bar{\alpha}}{|\alpha|^2} - \frac{\bar{z}_0}{|\alpha|^2} \cdot \alpha + |z_0|^2 = 4r^2$

$\Rightarrow 1 - z_0\bar{\alpha} - \bar{z}_0\alpha + |\alpha|^2|z_0|^2 = 4r^2|\alpha|^2$... (ii)

On subtracting Eqs. (i) and (ii), we get

$(|\alpha|^2 - 1) + |z_0|^2(1 - |\alpha|^2) = r^2(1 - 4|\alpha|^2)$

$\Rightarrow (|\alpha|^2 - 1)(1 - |z_0|^2) = r^2(1 - 4|\alpha|^2)$

$\Rightarrow (|\alpha|^2 - 1) \left(1 - \frac{r^2 + 2}{2} \right) = r^2(1 - 4|\alpha|^2)$

Given, $|z_0|^2 = \frac{r^2 + 2}{2}$

$\Rightarrow (|\alpha|^2 - 1) \cdot \left(\frac{-r^2}{2} \right) = r^2(1 - 4|\alpha|^2)$

$\Rightarrow |\alpha|^2 - 1 = -2 + 8|\alpha|^2 \Rightarrow 7|\alpha|^2 = 1$

$\therefore |\alpha| = 1/\sqrt{7}$

9. **PLAN** If $ax^2 + bx + c = 0$ has roots α, β , then

$\alpha, \beta = \frac{-b \pm \sqrt{b^2 - 4ac}}{2a}$

For roots to be real $b^2 - 4ac \geq 0$.

Description of Situation As imaginary part of $z = x + iy$ is non-zero.

$\Rightarrow y \neq 0$

Method I Let $z = x + iy$

$\therefore a = (x + iy)^2 + (x + iy) + 1$

$\Rightarrow (x^2 - y^2 + x + 1 - a) + i(2xy + y) = 0$

$\Rightarrow (x^2 - y^2 + x + 1 - a) + iy(2x + 1) = 0$, ... (i)

12 Complex Numbers

It is purely real, if $y(2x+1)=0$

but imaginary part of z , i.e. y is non-zero.

$$\Rightarrow 2x+1=0 \text{ or } x=-1/2$$

$$\text{From Eq. (i), } \frac{1}{4} - y^2 - \frac{1}{2} + 1 - a = 0$$

$$\Rightarrow a = -y^2 + \frac{3}{4} \Rightarrow a < \frac{3}{4}$$

Method II Here, $z^2 + z + (1-a) = 0$

$$\therefore z = \frac{-1 \pm \sqrt{1-4(1-a)}}{2 \times 1}$$

$$\Rightarrow z = \frac{-1 \pm \sqrt{4a-3}}{2}$$

For z do not have real roots, $4a-3 < 0 \Rightarrow a < \frac{3}{4}$

10. Since, $z\bar{z}(z^2 + \bar{z}^2) = 350$

$$\Rightarrow 2(x^2 + y^2)(x^2 - y^2) = 350$$

$$\Rightarrow (x^2 + y^2)(x^2 - y^2) = 175$$

Since, $x, y \in I$, the only possible case which gives integral solution, is

$$x^2 + y^2 = 25 \quad \dots \text{ (i)}$$

$$x^2 - y^2 = 7 \quad \dots \text{ (ii)}$$

From Eqs. (i) and (ii),

$$x^2 = 16, y^2 = 9 \Rightarrow x = \pm 4, y = \pm 3$$

\therefore Area of rectangle = $8 \times 6 = 48$

11. Let $z = \cos \theta + i \sin \theta$

$$\begin{aligned} \Rightarrow \frac{z}{1-z^2} &= \frac{\cos \theta + i \sin \theta}{1 - (\cos 2\theta + i \sin 2\theta)} \\ &= \frac{\cos \theta + i \sin \theta}{2 \sin^2 \theta - 2i \sin \theta \cos \theta} \\ &= \frac{\cos \theta + i \sin \theta}{-2i \sin \theta (\cos \theta + i \sin \theta)} = \frac{i}{2 \sin \theta} \end{aligned}$$

Hence, $\frac{z}{1-z^2}$ lies on the imaginary axis i.e. Y -axis.

Alternate Solution

Let $E = \frac{z}{1-z^2} = \frac{z}{z\bar{z} - z^2} = \frac{1}{\bar{z} - z}$ which is an imaginary.

12. Let $z_1 = \frac{w - \bar{w}z}{1-z}$ be purely real $\Rightarrow z_1 = \bar{z}_1$

$$\therefore \frac{w - \bar{w}z}{1-z} = \frac{\bar{w} - w\bar{z}}{1-\bar{z}}$$

$$\Rightarrow w - w\bar{z} - \bar{w}z + \bar{w}z\bar{z} = \bar{w} - z\bar{w} - w\bar{z} + wz\bar{z}$$

$$\Rightarrow (w - \bar{w}) + (\bar{w} - w)|z|^2 = 0$$

$$\Rightarrow (w - \bar{w})(1 - |z|^2) = 0$$

$$\Rightarrow |z|^2 = 1 \text{ [as } w - \bar{w} \neq 0, \text{ since } \beta \neq 0]$$

$$\Rightarrow |z| = 1 \text{ and } z \neq 1$$

13. Since, $|z| = 1$ and $w = \frac{z-1}{z+1}$

$$\Rightarrow z-1 = wz + w \Rightarrow z = \frac{1+w}{1-w} \Rightarrow |z| = \frac{|1+w|}{|1-w|}$$

$$\Rightarrow |1-w| = |1+w| \quad [\because |z| = 1]$$

On squaring both sides, we get

$$1 + |w|^2 - 2|w| \operatorname{Re}(w) = 1 + |w|^2 + 2|w| \operatorname{Re}(w)$$

$$\text{[using } |z_1 \pm z_2|^2 = |z_1|^2 + |z_2|^2 \pm 2|z_1||z_2| \operatorname{Re}(\bar{z}_1 z_2)]$$

$$\Rightarrow 4|w| \operatorname{Re}(w) = 0$$

$$\Rightarrow \operatorname{Re}(w) = 0$$

14. We know, $|z_1 - z_2| = |z_1 - (z_2 - 3 - 4i) - (3 + 4i)|$

$$\geq |z_1| - |z_2 - 3 - 4i| - |3 + 4i|$$

$$\geq 12 - 5 - 5 \quad \text{[using } |z_1 - z_2| \geq |z_1| - |z_2|]$$

$$\therefore |z_1 - z_2| \geq 2$$

Alternate Solution

Clearly from the figure $|z_1 - z_2|$ is minimum when z_1, z_2 lie along the diameter.

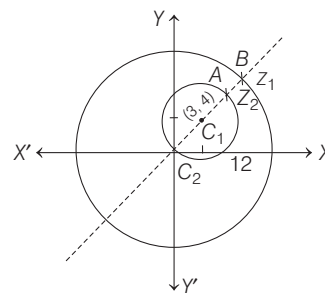

$$\therefore |z_1 - z_2| \geq C_2B - C_2A \geq 12 - 10 = 2$$

15. Given, $|z_1| = |z_2| = |z_3| = 1$

Now, $|z_1| = 1$

$$\Rightarrow |z_1|^2 = 1$$

$$\Rightarrow z_1 \bar{z}_1 = 1$$

Similarly, $z_2 \bar{z}_2 = 1, z_3 \bar{z}_3 = 1$

Again now, $\left| \frac{1}{z_1} + \frac{1}{z_2} + \frac{1}{z_3} \right| = 1$

$$\Rightarrow |\bar{z}_1 + \bar{z}_2 + \bar{z}_3| = 1 \Rightarrow |z_1 + z_2 + z_3| = 1$$

$$\Rightarrow |z_1 + z_2 + z_3| = 1$$

16. $(1+i)^{n_1} + (1-i)^{n_1} + (1+i)^{n_2} + (1-i)^{n_2}$

$$= [{}^n C_0 + {}^n C_1 i + {}^n C_2 i^2 + {}^n C_3 i^3 + \dots]$$

$$+ [{}^n C_0 - {}^n C_1 i + {}^n C_2 i^2 - {}^n C_3 i^3 + \dots]$$

$$+ [{}^{n_2} C_0 + {}^{n_2} C_1 i + {}^{n_2} C_2 i^2 + {}^{n_2} C_3 i^3 + \dots]$$

$$+ [{}^{n_2} C_0 - {}^{n_2} C_1 i + {}^{n_2} C_2 i^2 - {}^{n_2} C_3 i^3 + \dots]$$

$$= 2 [{}^n C_0 + {}^n C_2 i^2 + {}^n C_4 i^4 + \dots]$$

$$+ 2 [{}^{n_2} C_0 + {}^{n_2} C_2 i^2 + {}^{n_2} C_4 i^4 + \dots]$$

$$= 2 [{}^n C_0 - {}^n C_2 + {}^n C_4 - \dots] + 2 [{}^{n_2} C_0 - {}^{n_2} C_2 + {}^{n_2} C_4 - \dots]$$

This is a real number irrespective of the values of n_1 and n_2 .

Alternate Solution

$$\{(1+i)^{n_1} + (1-i)^{n_1}\} + \{(1+i)^{n_2} + (1-i)^{n_2}\}$$

\Rightarrow A real number for all n_1 and $n_2 \in R$.

$$[\because z + \bar{z} = 2 \operatorname{Re}(z) \Rightarrow (1+i)^n + (1-i)^n \text{ is real number for all } n \in R]$$

17. Since, $\overline{(\sin x + i \cos 2x)} = \cos x - i \sin 2x$
 $\Rightarrow \sin x - i \cos 2x = \cos x - i \sin 2x$
 $\Rightarrow \sin x = \cos x$ and $\cos 2x = \sin 2x$
 $\Rightarrow \tan x = 1$ and $\tan 2x = 1$
 $\Rightarrow x = \pi/4$ and $x = \pi/8$ which is not possible at same time.
Hence, no solution exists.
18. Since, z_1, z_2, z_3, z_4 are the vertices of parallelogram.

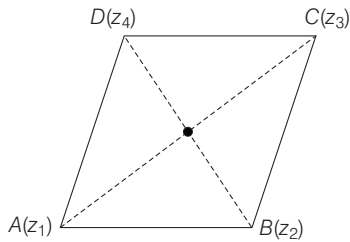

- \therefore Mid-point of $AC =$ mid-point of BD
 $\Rightarrow \frac{z_1 + z_3}{2} = \frac{z_2 + z_4}{2}$
 $\Rightarrow z_1 + z_3 = z_2 + z_4$
19. Since, $|w| = 1 \Rightarrow \left| \frac{1-iz}{z-i} \right| = 1$
 $\Rightarrow |z-i| = |1-iz|$
 $\Rightarrow |z-i| = |z+i|$ [$\because |1-iz| = |-i||z+i| = |z+i|$]
 \therefore It is a perpendicular bisector of $(0, 1)$ and $(0, -1)$
i.e. X -axis. Thus, z lies on the real axis.

20. Given, $|z-4| < |z-2|$
Since, $|z-z_1| > |z-z_2|$ represents the region on right side of perpendicular bisector of z_1 and z_2 .
 $\therefore |z-2| > |z-4|$
 $\Rightarrow \text{Re}(z) > 3$ and $\text{Im}(z) \in R$

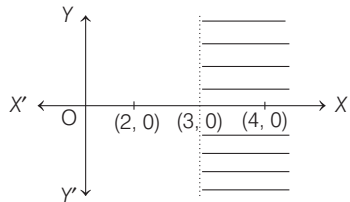

21. Given, $z = \left(\frac{\sqrt{3}}{2} + \frac{i}{2}\right)^5 + \left(\frac{\sqrt{3}}{2} - \frac{i}{2}\right)^5$
 $\left[\because \omega = \frac{-1+i\sqrt{3}}{2} \text{ and } \omega^2 = \frac{-1-i\sqrt{3}}{2} \right]$
- Now, $\frac{\sqrt{3}+i}{2} = -i \left(\frac{-1+i\sqrt{3}}{2}\right) = -i\omega$
and $\frac{\sqrt{3}-i}{2} = i \left(\frac{-1-i\sqrt{3}}{2}\right) = i\omega^2$
 $\therefore z = (-i\omega)^5 + (i\omega^2)^5 = -i\omega^2 + i\omega$
 $= i(\omega - \omega^2) = i(i\sqrt{3}) = -\sqrt{3}$
 $\Rightarrow \text{Re}(z) < 0$ and $\text{Im}(z) = 0$

Alternate Solution

We know that, $z + \bar{z} = 2 \text{Re}(z)$
If $z = \left(\frac{\sqrt{3}}{2} + \frac{i}{2}\right)^5 + \left(\frac{\sqrt{3}}{2} - \frac{i}{2}\right)^5$, then z is purely real. i.e. $\text{Im}(z) = 0$

22. Given, $\left| \frac{z-5i}{z+5i} \right| = 1 \Rightarrow |z-5i| = |z+5i|$
[\because if $|z-z_1| = |z-z_2|$, then it is a perpendicular bisector of z_1 and z_2]

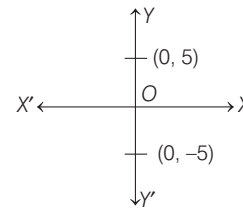

\therefore Perpendicular bisector of $(0, 5)$ and $(0, -5)$ is X -axis.

23. It is given that the complex number Z , satisfying
 $|z^2 + z + 1| = 1$
 $\Rightarrow \left| \left(z + \frac{1}{2}\right)^2 + \frac{3}{4} \right| = 1$
 $\therefore |z_1 - z_2| \geq ||z_1| - |z_2||$
 $\therefore \left| \left(z + \frac{1}{2}\right)^2 - \left(-\frac{3}{4}\right) \right| \geq \left| \left|z + \frac{1}{2}\right|^2 - \left|-\frac{3}{4}\right| \right|$
 $\Rightarrow \left| \left|z + \frac{1}{2}\right|^2 - \frac{3}{4} \right| \leq 1$
 $\Rightarrow -1 \leq \left|z + \frac{1}{2}\right|^2 - \frac{3}{4} \leq 1$
 $\Rightarrow -\frac{1}{4} \leq \left|z + \frac{1}{2}\right|^2 \leq \frac{7}{4}$
 $\Rightarrow 0 \leq \left|z + \frac{1}{2}\right|^2 \leq \frac{7}{4}$ [$\because |z| \geq 0$]
 $\Rightarrow 0 \leq \left|z + \frac{1}{2}\right| \leq \frac{\sqrt{7}}{2}$... (i)
 $\therefore \left|z + \frac{1}{2}\right| \leq \frac{\sqrt{7}}{2}$
 $\therefore |z_1 + z_2| \geq ||z_1| - |z_2||$
 $\therefore \left|z + \frac{1}{2}\right| \geq \left|z - \frac{1}{2}\right|$
 $\Rightarrow \left|z - \frac{1}{2}\right| \leq \left|z + \frac{1}{2}\right| \leq \frac{\sqrt{7}}{2}$
 $\Rightarrow -\frac{\sqrt{7}}{2} \leq |z - \frac{1}{2}| \leq \frac{\sqrt{7}}{2}$
 $\Rightarrow \frac{1 - \sqrt{7}}{2} \leq |z| \leq \frac{\sqrt{7} + 1}{2}$
 $\Rightarrow |z| \leq \frac{1 + \sqrt{7}}{2}$
 $\therefore |z| \leq 2$

14 Complex Numbers

$$\begin{aligned} \therefore & \left| \left(z + \frac{1}{2} \right)^2 + \frac{3}{4} \right| \leq \left| \left| z + \frac{1}{2} \right|^2 + \frac{3}{4} \right| \\ \Rightarrow & 1 \leq \left| \left| z + \frac{1}{2} \right|^2 + \frac{3}{4} \right| \Rightarrow \left| z + \frac{1}{2} \right|^2 + \frac{3}{4} \geq 1 \\ \Rightarrow & \left| z + \frac{1}{2} \right|^2 \geq \frac{1}{4} \Rightarrow \left| z + \frac{1}{2} \right| \geq \frac{1}{2} \quad \dots \text{(ii)} \end{aligned}$$

From Eqs. (i) and (ii), we get

$$\frac{1}{2} \leq \left| z + \frac{1}{2} \right| \leq \frac{\sqrt{7}}{2}$$

24. We have,

$$sz + t\bar{z} + r = 0 \quad \dots \text{(i)}$$

On taking conjugate

$$\bar{s}\bar{z} + \bar{t}z + \bar{r} = 0 \quad \dots \text{(ii)}$$

On solving Eqs. (i) and (ii), we get

$$z = \frac{\bar{r}t - r\bar{s}}{|s|^2 - |t|^2}$$

(a) For unique solutions of z

$$|s|^2 - |t|^2 \neq 0 \Rightarrow |s| \neq |t|$$

It is true

(b) If $|s| = |t|$, then $\bar{r}t - r\bar{s}$ may or may not be zero.

So, z may have no solutions.

$\therefore L$ may be an empty set.

It is false.

(c) If elements of set L represents line, then this line and given circle intersect at maximum two point.

Hence, it is true.

(d) In this case locus of z is a line, so L has infinite elements. Hence, it is true.

25. Given, $|z_1| = |z_2|$

$$\begin{aligned} \text{Now, } \frac{z_1 + z_2}{z_1 - z_2} \times \frac{\bar{z}_1 - \bar{z}_2}{z_1 - z_2} &= \frac{z_1\bar{z}_1 - z_1\bar{z}_2 + z_2\bar{z}_1 - z_2\bar{z}_2}{|z_1 - z_2|^2} \\ &= \frac{|z_1|^2 + (z_2\bar{z}_1 - z_1\bar{z}_2) - |z_2|^2}{|z_1 - z_2|^2} \\ &= \frac{z_2\bar{z}_1 - z_1\bar{z}_2}{|z_1 - z_2|^2} \quad [\because |z_1|^2 = |z_2|^2] \end{aligned}$$

As, we know $z - \bar{z} = 2i \operatorname{Im}(z)$

$$\therefore z_2\bar{z}_1 - z_1\bar{z}_2 = 2i \operatorname{Im}(z_2\bar{z}_1)$$

$$\therefore \frac{z_1 + z_2}{z_1 - z_2} = \frac{2i \operatorname{Im}(z_2\bar{z}_1)}{|z_1 - z_2|^2}$$

which is purely imaginary or zero.

26. Since, $z_1 = a + ib$ and $z_2 = c + id$

$$\Rightarrow |z_1|^2 = a^2 + b^2 = 1 \text{ and } |z_2|^2 = c^2 + d^2 = 1 \quad \dots \text{(i)}$$

$$[\because |z_1| = |z_2| = 1]$$

Also, $\operatorname{Re}(z_1\bar{z}_2) = 0 \Rightarrow ac + bd = 0$

$$\Rightarrow \frac{a}{b} = -\frac{d}{c} = \lambda \quad [\text{say}] \dots \text{(ii)}$$

From Eqs. (i) and (ii), $b^2\lambda^2 + b^2 = c^2 + \lambda^2c^2$

$$\Rightarrow b^2 = c^2 \text{ and } a^2 = d^2$$

Also, given $w_1 = a + ic$ and $w_2 = b + id$

$$\text{Now, } |w_1| = \sqrt{a^2 + c^2} = \sqrt{a^2 + b^2} = 1$$

$$|w_2| = \sqrt{b^2 + d^2} = \sqrt{a^2 + b^2} = 1$$

$$\begin{aligned} \text{and } \operatorname{Re}(w_1\bar{w}_2) &= ab + cd = (b\lambda)b + c(-\lambda c) \quad [\text{from Eq. (i)}] \\ &= \lambda(b^2 - c^2) = 0 \end{aligned}$$

27. $\min_{Z \in S} |1 - 3i - z|$ = perpendicular distance of point $(1, -3)$

$$\text{from the line } \sqrt{3}x + y = 0 \Rightarrow \frac{|\sqrt{3} - 3|}{\sqrt{3 + 1}} = \frac{3 - \sqrt{3}}{2}$$

28. Since, $S = S_1 \cap S_2 \cap S_3$

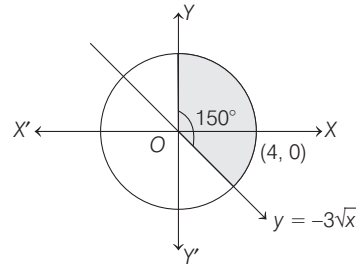

Clearly, the shaded region represents the area of sector

$$\therefore S = \frac{1}{2} r^2 \theta = \frac{1}{2} \times 4^2 \times \frac{5\pi}{6} = \frac{20\pi}{3}$$

29. Since, $|w - (2 + i)| < 3 \Rightarrow |w| - |2 + i| < 3$

$$\Rightarrow -3 + \sqrt{5} < |w| < 3 + \sqrt{5}$$

$$\Rightarrow -3 - \sqrt{5} < -|w| < 3 - \sqrt{5} \quad \dots \text{(i)}$$

$$\text{Also, } |z - (2 + i)| = 3$$

$$\Rightarrow -3 + \sqrt{5} \leq |z| \leq 3 + \sqrt{5} \quad \dots \text{(ii)}$$

$$\therefore -3 < |z| - |w| < 3 + 9$$

30. $|z + 1 - i|^2 + |z - 5 - i|^2$

$$= (x + 1)^2 + (y - 1)^2 + (x - 5)^2 + (y - 1)^2$$

$$= 2(x^2 + y^2 - 4x - 2y) + 28$$

$$= 2(4) + 28 = 36 \quad [\because x^2 + y^2 - 4x - 2y = 4]$$

31. Let $z = x + iy$

Set A corresponds to the region $y \geq 1$... (i)

Set B consists of points lying on the circle, centre at $(2, 1)$ and radius 3.

$$\text{i.e. } x^2 + y^2 - 4x - 2y = 4 \quad \dots \text{(ii)}$$

Set C consists of points lying on the $x + y = \sqrt{2}$... (iii)

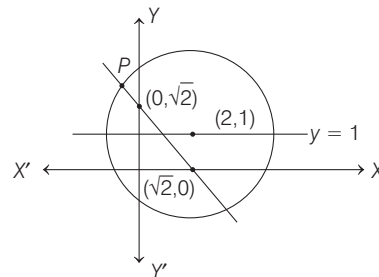

Clearly, there is only one point of intersection of the line $x + y = \sqrt{2}$ and circle $x^2 + y^2 - 4x - 2y = 4$.

32. A. Let $z = x + iy$
 \Rightarrow we get $y\sqrt{x^2 + y^2} = 0$
 $\Rightarrow y = 0 \Rightarrow \text{Im}(z) = 0$
 B. We have $2ae = 8, 2a = 10 \Rightarrow 10e = 8$
 $\Rightarrow e = \frac{4}{5} \Rightarrow b^2 = 25 \left(1 - \frac{16}{25}\right) = 9$
 $\therefore \frac{x^2}{25} + \frac{y^2}{9} = 1$

C. Let $w = 2(\cos \theta + i \sin \theta)$
 $\therefore z = 2(\cos \theta + i \sin \theta) - \frac{1}{2(\cos \theta + i \sin \theta)}$
 $= 2(\cos \theta + i \sin \theta) - \frac{1}{2}(\cos \theta - i \sin \theta)$
 $= \frac{3}{2} \cos \theta + \frac{5}{2} i \sin \theta$

Let $z = x + iy$
 $\Rightarrow x = \frac{3}{2} \cos \theta$ and $y = \frac{5}{2} \sin \theta$
 $\Rightarrow \left(\frac{2x}{3}\right)^2 + \left(\frac{2y}{5}\right)^2 = 1$
 $\Rightarrow \frac{x^2}{9/4} + \frac{y^2}{25/4} = 1$
 $\therefore e = \sqrt{1 - \frac{9/4}{25/4}} = \frac{4}{5}$

D. Let $w = \cos \theta + i \sin \theta$
 Then, $z = x + iy = \cos \theta + i \sin \theta + \frac{1}{\cos \theta + i \sin \theta}$
 $= 2 \cos \theta$
 $\Rightarrow x = 2 \cos \theta, y = 0$

33. $\frac{x\alpha + y\beta + z\gamma}{x\beta + y\gamma + z\alpha} = \frac{x(p)^{1/3} + y(p)^{1/3}\omega + z(p)^{1/3}\omega^2}{x(p)^{1/3}\omega^2 + y(p)^{1/3}\omega^3 + z(p)^{1/3}\omega}$
 $= \frac{\omega^2(x + y\omega + z\omega^2)}{\omega^2(x\omega + y\omega^2 + z)}$
 $= \frac{\omega^2(x + y\omega + z\omega^2)}{x + y\omega + z\omega^2} = \omega^2$

34. $|az_1 - bz_2|^2 + |bz_1 + az_2|^2$
 $= [a^2|z_1|^2 + b^2|z_2|^2 - 2ab \text{Re}(z_1\bar{z}_2)]$
 $+ [b^2|z_1|^2 + a^2|z_2|^2 + 2ab \text{Re}(z_1\bar{z}_2)]$
 $= (a^2 + b^2)(|z_1|^2 + |z_2|^2)$

35. $\frac{\left(\sin \frac{x}{2} + \cos \frac{x}{2}\right) - i \tan x}{1 + 2i \sin \frac{x}{2}} \in R$
 $= \frac{\left(\sin \frac{x}{2} + \cos \frac{x}{2} - i \tan x\right)\left(1 - 2i \sin \frac{x}{2}\right)}{1 + 4 \sin^2 \frac{x}{2}}$

Since, it is real, so imaginary part will be zero.

$\therefore -2 \sin \frac{x}{2} \left(\sin \frac{x}{2} + \cos \frac{x}{2}\right) - \tan x = 0$
 $\Rightarrow 2 \sin \frac{x}{2} \left(\sin \frac{x}{2} + \cos \frac{x}{2}\right) \cos x + 2 \sin \frac{x}{2} \cos \frac{x}{2} = 0$
 $\Rightarrow \sin \frac{x}{2} \left[\left(\sin \frac{x}{2} + \cos \frac{x}{2}\right)\left(\cos^2 \frac{x}{2} - \sin^2 \frac{x}{2}\right) + \cos \frac{x}{2}\right] = 0$
 $\therefore \sin \frac{x}{2} = 0$
 $\Rightarrow x = 2n\pi \dots (i)$
 or $\left(\sin \frac{x}{2} + \cos \frac{x}{2}\right)\left(\cos^2 \frac{x}{2} - \sin^2 \frac{x}{2}\right) + \cos \frac{x}{2} = 0$

On dividing by $\cos^3 \frac{x}{2}$, we get

$\left(\tan \frac{x}{2} + 1\right)\left(1 - \tan^2 \frac{x}{2}\right) + \left(1 + \tan^2 \frac{x}{2}\right) = 0$
 $\Rightarrow \tan^3 \frac{x}{2} - \tan \frac{x}{2} - 2 = 0$

Let $\tan \frac{x}{2} = t$
 and $f(t) = t^3 - t - 2$
 Then, $f(1) = -2 < 0$
 and $f(2) = 4 > 0$

Thus, $f(t)$ changes sign from negative to positive in the interval $(1, 2)$.

\therefore Let $t = k$ be the root for which $f(k) = 0$ and $k \in (1, 2)$
 $\therefore t = k$ or $\tan \frac{x}{2} = k = \tan \alpha$
 $\Rightarrow \frac{x}{2} = n\pi + \alpha$
 $\Rightarrow \begin{cases} x = 2n\pi + 2\alpha, \alpha = \tan^{-1} k, \text{ where } k \in (1, 2) \\ \text{or } x = 2n\pi \end{cases}$

36. Since, z_1, z_2, z_3 are in AP.

$\Rightarrow 2z_2 = z_1 + z_3$
 i.e. points are collinear, thus do not lie on circle. Hence, it is a false statement.

37. Since, z_1, z_2, z_3 are vertices of equilateral triangle and

$|z_1| = |z_2| = |z_3|$
 $\Rightarrow z_1, z_2, z_3$ lie on a circle with centre at origin.
 \Rightarrow Circumcentre = Centroid
 $\Rightarrow 0 = \frac{z_1 + z_2 + z_3}{3}$

$\therefore z_1 + z_2 + z_3 = 0$

38. Let $z = x + iy \Rightarrow 1 \cap z$ gives $1 \cap x + iy$

or $1 \leq x$ and $0 \leq y \dots (i)$
 Given, $\frac{1-z}{1+z} \cap 0 \Rightarrow \frac{1-x-iy}{1+x+iy} \cap 0$
 $\Rightarrow \frac{(1-x-iy)(1+x-iy)}{(1+x+iy)(1+x-iy)} \cap 0 + 0i$

16 Complex Numbers

$$\Rightarrow \frac{1-x^2-y^2}{(1+x)^2+y^2} - \frac{2iy}{(1+x)^2+y^2} \cap 0+0i$$

$$\Rightarrow x^2+y^2 \geq 1 \text{ and } -2y \leq 0$$

or $x^2+y^2 \geq 1$ and $y \geq 0$ which is true by Eq. (i).

39. As we know, $|z|^2 = z \cdot \bar{z}$

$$\text{Given, } \frac{|z-\alpha|^2}{|z-\beta|^2} = k^2$$

$$\Rightarrow (z-\alpha)(\bar{z}-\bar{\alpha}) = k^2(z-\beta)(\bar{z}-\bar{\beta})$$

$$\Rightarrow |z|^2 - \alpha\bar{z} - \bar{\alpha}z + |\alpha|^2 = k^2(|z|^2 - \beta\bar{z} - \bar{\beta}z + |\beta|^2)$$

$$\Rightarrow |z|^2(1-k^2) - (\alpha-k^2\beta)\bar{z} - (\bar{\alpha}-\bar{\beta}k^2)z + (|\alpha|^2 - k^2|\beta|^2) = 0$$

$$\Rightarrow |z|^2 - \frac{(\alpha-k^2\beta)}{(1-k^2)}\bar{z} - \frac{(\bar{\alpha}-\bar{\beta}k^2)}{(1-k^2)}z + \frac{|\alpha|^2 - k^2|\beta|^2}{(1-k^2)} = 0 \dots(i)$$

On comparing with equation of circle,

$$|z|^2 + a\bar{z} + \bar{a}z + b = 0$$

whose centre is $(-a)$ and radius $= \sqrt{|a|^2 - b}$

$$\therefore \text{Centre for Eq. (i)} = \frac{\alpha - k^2\beta}{1 - k^2}$$

$$\text{and radius} = \sqrt{\left(\frac{\alpha - k^2\beta}{1 - k^2}\right)\left(\frac{\bar{\alpha} - \bar{\beta}k^2}{1 - k^2}\right) - \frac{\alpha\bar{\alpha} - k^2\beta\bar{\beta}}{1 - k^2}}$$

$$= \left| \frac{k(\alpha - \beta)}{1 - k^2} \right|$$

40. Given, $a_1z + a_2z^2 + \dots + a_nz^n = 1$

$$\text{and } |z| < \frac{1}{3} \dots(i)$$

$$\therefore |a_1z + a_2z^2 + a_3z^3 + \dots + a_nz^n| = 1$$

$$\Rightarrow |a_1z| + |a_2z^2| + |a_3z^3| + \dots + |a_nz^n| \geq 1$$

$$\text{[using } |z_1 + z_2| \leq |z_1| + |z_2| \text{]}$$

$$\Rightarrow 2(|z| + |z|^2 + |z|^3 + \dots + |z|^n) > 1 \text{ [using } |a_r| < 2 \text{]}$$

$$\Rightarrow \frac{2|z|(1-|z|^n)}{1-|z|} > 1 \text{ [using sum of } n \text{ terms of GP]}$$

$$\Rightarrow 2|z| - 2|z|^{n+1} > 1 - |z|$$

$$\Rightarrow 3|z| > 1 + 2|z|^{n+1}$$

$$\Rightarrow |z| > \frac{1}{3} + \frac{2}{3}|z|^{n+1}$$

$$\Rightarrow |z| > \frac{1}{3}, \text{ which contradicts } \dots(ii)$$

\therefore There exists no complex number z such that

$$|z| < 1/3 \text{ and } \sum_{r=1}^n a_r z^r = 1$$

41. Given, $|z_1| < 1$ and $|z_2| > 1$ $\dots(i)$

Then, to prove

$$\left| \frac{1 - z_1\bar{z}_2}{z_1 - z_2} \right| < 1 \quad \left[\text{using } \left| \frac{z_1}{z_2} \right| = \frac{|z_1|}{|z_2|} \right]$$

$$\Rightarrow |1 - z_1\bar{z}_2| < |z_1 - z_2| \dots(ii)$$

On squaring both sides, we get,

$$(1 - z_1\bar{z}_2)(1 - \bar{z}_1z_2) < (z_1 - z_2)(\bar{z}_1 - \bar{z}_2) \text{ [using } |z|^2 = z\bar{z} \text{]}$$

$$\Rightarrow 1 - z_1\bar{z}_2 - \bar{z}_1z_2 + z_1\bar{z}_1z_2\bar{z}_2 < z_1\bar{z}_1 - z_1\bar{z}_2 - z_2\bar{z}_1 + z_2\bar{z}_2$$

$$\Rightarrow 1 + |z_1|^2|z_2|^2 < |z_1|^2 + |z_2|^2$$

$$\Rightarrow 1 - |z_1|^2 - |z_2|^2 + |z_1|^2|z_2|^2 < 0$$

$$\Rightarrow (1 - |z_1|^2)(1 - |z_2|^2) < 0 \dots(iii)$$

which is true by Eq. (i) as $|z_1| < 1$ and $|z_2| > 1$

$$\therefore (1 - |z_1|^2) > 0 \text{ and } (1 - |z_2|^2) < 0$$

\therefore Eq. (iii) is true whenever Eq. (ii) is true.

$$\Rightarrow \left| \frac{1 - z_1\bar{z}_2}{z_1 - z_2} \right| < 1 \quad \text{Hence proved.}$$

42. Given, $|z|^2 w - |w|^2 z = z - w$

$$\Rightarrow z\bar{z}w - w\bar{w}z = z - w \quad [\because |z|^2 = z\bar{z}] \dots(i)$$

Taking modulus of both sides, we get

$$|zw||\bar{z} - \bar{w}| = |z - w|$$

$$\Rightarrow |zw||\bar{z} - \bar{w}| = |\overline{z - w}| \quad [\because |z| = |\bar{z}|]$$

$$\Rightarrow |zw||\bar{z} - \bar{w}| = |\bar{z} - \bar{w}|$$

$$\Rightarrow |\bar{z} - \bar{w}|(|zw| - 1) = 0$$

$$\Rightarrow |\bar{z} - \bar{w}| = 0 \quad \text{or} \quad |zw| - 1 = 0$$

$$\Rightarrow |z - w| = 0 \quad \text{or} \quad |zw| = 1$$

$$\Rightarrow z - w = 0 \quad \text{or} \quad |zw| = 1$$

$$\Rightarrow z = w \quad \text{or} \quad |zw| = 1$$

Now, suppose $z \neq w$

Then, $|zw| = 1$ or $|z||w| = 1$

$$\Rightarrow |z| = \frac{1}{|w|} = r \quad \text{[say]}$$

$$\text{Let } z = re^{i\theta} \text{ and } w = \frac{1}{r}e^{i\phi}$$

On putting these values in Eq. (i), we get

$$r^2 \left(\frac{1}{r}e^{i\phi} \right) - \frac{1}{r^2} (re^{i\theta}) = re^{i\theta} - \frac{1}{r}e^{i\phi}$$

$$\Rightarrow re^{i\phi} - \frac{1}{r}e^{i\theta} = re^{i\theta} - \frac{1}{r}e^{i\phi}$$

$$\Rightarrow \left(r + \frac{1}{r} \right) e^{i\phi} = \left(r + \frac{1}{r} \right) e^{i\theta}$$

$$\Rightarrow e^{i\phi} = e^{i\theta} \Rightarrow \phi = \theta$$

$$\text{Therefore, } z = re^{i\theta} \text{ and } w = \frac{1}{r}e^{i\theta}$$

$$\Rightarrow z\bar{w} = re^{i\theta} \cdot \frac{1}{r}e^{-i\theta} = 1$$

NOTE 'if and only if' means we have to prove the relation in both directions.

Conversely

Assuming that $z = w$ or $z\bar{w} = 1$

If $z = w$, then

$$\text{LHS} = z\bar{z}w - w\bar{w}z = |z|^2z - |w|^2z = |z|^2z - |z|^2z = 0$$

$$\text{and RHS} = z - w = 0$$

If $zw = 1$, then $\bar{z}\bar{w} = 1$ and

$$\text{LHS} = z\bar{z}w - w\bar{w}z = \bar{z} \cdot 1 - \bar{w} \cdot 1 = \bar{z} - \bar{w} = z - w = 0 = \text{RHS}$$

Hence proved.

Alternate Solution

We have, $|z|^2 w - |w|^2 z = z - w$
 $\Leftrightarrow |z|^2 w - |w|^2 z - z + w = 0$
 $\Leftrightarrow (|z|^2 + 1)w - (|w|^2 + 1)z = 0$
 $\Leftrightarrow (|z|^2 + 1)w = (|w|^2 + 1)z$
 $\Leftrightarrow \frac{z}{w} = \frac{|z|^2 + 1}{|w|^2 + 1}$
 $\therefore \frac{z}{w}$ is purely real.
 $\Leftrightarrow \frac{\bar{z}}{\bar{w}} = \frac{z}{w} \Rightarrow z\bar{w} = \bar{z}w \quad \dots(i)$

Again, $|z|^2 w - |w|^2 z = z - w$
 $\Leftrightarrow z \cdot \bar{z}w - w \cdot \bar{w}z = z - w$
 $\Leftrightarrow z(\bar{z}w - 1) - w(\bar{w}z - 1) = 0$
 $\Leftrightarrow (z - w)(\bar{z}w - 1) = 0 \quad [\text{from Eq. (i)}]$
 $\Leftrightarrow z = w \text{ or } \bar{z}w = 1$

Therefore, $|z|^2 w - |w|^2 z = z - w$ if and only if $z = w$ or $\bar{z}w = 1$.

43. Let $z = x + iy$.
 Given, $\bar{z} = iz^2$
 $\Rightarrow \overline{(x + iy)} = i(x + iy)^2$
 $\Rightarrow x - iy = i(x^2 - y^2 + 2ixy)$
 $\Rightarrow x - iy = -2xy + i(x^2 - y^2)$

NOTE It is a compound equation, therefore we can generate from it more than one primary equations.

On equating real and imaginary parts, we get

$x = -2xy \text{ and } -y = x^2 - y^2$
 $\Rightarrow x + 2xy = 0 \text{ and } x^2 - y^2 + y = 0$
 $\Rightarrow x(1 + 2y) = 0$
 $\Rightarrow x = 0 \text{ or } y = -1/2$

When $x = 0$, $x^2 - y^2 + y = 0 \Rightarrow 0 - y^2 + y = 0$
 $\Rightarrow y(1 - y) = 0 \Rightarrow y = 0 \text{ or } y = 1$

When, $y = -1/2$, $x^2 - y^2 + y = 0$
 $\Rightarrow x^2 - \frac{1}{4} - \frac{1}{2} = 0 \Rightarrow x^2 = \frac{3}{4}$
 $\Rightarrow x = \pm \frac{\sqrt{3}}{2}$

Therefore, $z = 0 + i0, 0 + i; \pm \frac{\sqrt{3}}{2} - \frac{i}{2}$
 $\Rightarrow z = i, \pm \frac{\sqrt{3}}{2} - \frac{i}{2} \quad [\because z \neq 0]$

44. Given, $iz^3 + z^2 - z + i = 0$
 $\Rightarrow iz^3 - i^2z^2 - z + i = 0 \quad [\because i^2 = -1]$
 $\Rightarrow iz^2(z - i) - 1(z - i) = 0$
 $\Rightarrow (iz^2 - 1)(z - i) = 0$
 $\Rightarrow z - i = 0 \text{ or } iz^2 - 1 = 0$
 $\Rightarrow z = i \text{ or } z^2 = \frac{1}{i} = -i$
 If $z = i$, then $|z| = |i| = 1$
 If $z^2 = -i$, then $|z^2| = |-i| = 1$
 $\Rightarrow |z|^2 = 1 \Rightarrow |z| = 1$

45. Here, $z_1 R z_2 \Leftrightarrow \frac{z_1 - z_2}{z_1 + z_2}$ is real
 (i) **Reflexive** $z_1 R z_1 \Leftrightarrow \frac{z_1 - z_1}{z_1 + z_1} = 0$ [purely real]
 $\therefore z_1 R z_1$ is reflexive.

(ii) **Symmetric** $z_1 R z_2 \Leftrightarrow \frac{z_1 - z_2}{z_1 + z_2}$ is real
 $\Rightarrow \frac{-(z_2 - z_1)}{z_1 + z_2}$ is real $\Rightarrow z_2 R z_1$
 $\therefore z_1 R z_2 \Rightarrow z_2 R z_1$

Therefore, it is symmetric.

(iii) **Transitive** $z_1 R z_2$
 $\Rightarrow \frac{z_1 - z_2}{z_1 + z_2}$ is real

and $z_2 R z_3$
 $\Rightarrow \frac{z_2 - z_3}{z_2 + z_3}$ is real

Here, let $z_1 = x_1 + iy_1, z_2 = x_2 + iy_2$ and $z_3 = x_3 + iy_3$

$\therefore \frac{z_1 - z_2}{z_1 + z_2}$ is real $\Rightarrow \frac{(x_1 - x_2) + i(y_1 - y_2)}{(x_1 + x_2) + i(y_1 + y_2)}$ is real
 $\Rightarrow \frac{\{(x_1 - x_2) + i(y_1 - y_2)\}\{(x_1 + x_2) - i(y_1 + y_2)\}}{(x_1 + x_2)^2 + (y_1 + y_2)^2}$
 $\Rightarrow (y_1 - y_2)(x_1 + x_2) - (x_1 - x_2)(y_1 + y_2) = 0$
 $\Rightarrow 2x_2y_1 - 2y_2x_1 = 0$
 $\Rightarrow \frac{x_1}{y_1} = \frac{x_2}{y_2} \quad \dots (i)$

Similarly, $z_2 R z_3$
 $\Rightarrow \frac{x_2}{y_2} = \frac{x_3}{y_3} \quad \dots (ii)$

From Eqs. (i) and (ii), we have $\frac{x_1}{y_1} = \frac{x_3}{y_3} \Rightarrow z_1 R z_3$

Thus, $z_1 R z_2$ and $z_2 R z_3 \Rightarrow z_1 R z_3$. [transitive]
 Hence, R is an equivalence relation.

46. $\frac{(1 + i)x - 2i}{3 + i} + \frac{(2 - 3i)y + i}{3 - i} = i$
 $\Rightarrow (1 + i)(3 - i)x - 2i(3 - i) + (3 + i)(2 - 3i)y + i(3 + i) = 10i$
 $\Rightarrow 4x + 2ix - 6i - 2 + 9y - 7iy + 3i - 1 = 10i$
 $\Rightarrow 4x + 9y - 3 = 0 \text{ and } 2x - 7y - 3 = 10$
 $\Rightarrow x = 3 \text{ and } y = -1$

47. Now, $\frac{1}{(1 - \cos \theta) + 2i \sin \theta} = \frac{1}{2 \sin^2 \frac{\theta}{2} + 4i \sin \frac{\theta}{2} \cos \frac{\theta}{2}}$
 $= \frac{1}{2 \sin \frac{\theta}{2} \left(\sin \frac{\theta}{2} + 2i \cos \frac{\theta}{2} \right)} \times \frac{\sin \frac{\theta}{2} - 2i \cos \frac{\theta}{2}}{\sin \frac{\theta}{2} - 2i \cos \frac{\theta}{2}}$

18 Complex Numbers

$$= \frac{\sin \frac{\theta}{2} - 2i \cos \frac{\theta}{2}}{2 \sin \frac{\theta}{2} \left(\sin^2 \frac{\theta}{2} + 4 \cos^2 \frac{\theta}{2} \right)}$$

$$= \frac{\sin \frac{\theta}{2} - 2i \cos \frac{\theta}{2}}{2 \sin \frac{\theta}{2} \left(1 + 3 \cos^2 \frac{\theta}{2} \right)}$$

$$\Rightarrow A + iB = \frac{1}{2 \left(1 + 3 \cos^2 \frac{\theta}{2} \right)} - i \frac{\cot \frac{\theta}{2}}{1 + 3 \cos^2 \frac{\theta}{2}}$$

48. Since, $(x + iy)^2 = \frac{a + ib}{c + id}$

$$\Rightarrow |x + iy|^2 = \frac{|a + ib|}{|c + id|} \quad \left[\because \frac{|z_1|}{|z_2|} = \frac{|z_1|}{|z_2|} \right]$$

$$\Rightarrow (x^2 + y^2) = \frac{\sqrt{a^2 + b^2}}{\sqrt{c^2 + d^2}}$$

$$\Rightarrow (x^2 + y^2)^2 = \frac{a^2 + b^2}{c^2 + d^2}$$

Hence proved.

49. Given, $|z - 3 - 2i| \leq 2$... (i)

To find minimum of $|2z - 6 + 5i|$

or $2 \left| z - 3 + \frac{5}{2}i \right|$, using triangle inequality

i.e. $||z_1| - |z_2|| \leq |z_1 + z_2|$

$$\therefore \left| z - 3 + \frac{5}{2}i \right| = \left| z - 3 - 2i + 2i + \frac{5}{2}i \right|$$

$$= \left| (z - 3 - 2i) + \frac{9}{2}i \right|$$

$$\geq \left| z - 3 - 2i \right| - \frac{9}{2} \geq 2 - \frac{9}{2} \geq \frac{5}{2}$$

$$\Rightarrow \left| z - 3 + \frac{5}{2}i \right| \geq \frac{5}{2} \text{ or } |2z - 6 + 5i| \geq 5$$

Topic 3 Argument of a Complex Number

1. Let the complex numbers

$$z_1 = x_1 + iy_1 \quad \text{and} \quad z_2 = x_2 + iy_2$$

Now, it is given that

$$\operatorname{Re}(z_1) = |z_1 - 1| \Rightarrow x_1^2 = (x_1 - 1)^2 + y_1^2$$

$$\Rightarrow y_1^2 + 1 = 2x_1 \quad \dots (i)$$

$$\text{and} \quad \operatorname{Re}(z_2) = |z_2 - 1| \Rightarrow x_2^2 = (x_2 - 1)^2 + y_2^2$$

$$\Rightarrow y_2^2 + 1 = 2x_2 \quad \dots (ii)$$

$$\text{and} \quad \arg(z_1 - z_2) = \frac{\pi}{6} \Rightarrow \frac{y_1 - y_2}{x_1 - x_2} = \frac{1}{\sqrt{3}} \quad \dots (iii)$$

From Eqs. (i) and (ii), we get

$$y_1^2 - y_2^2 = 2(x_1 - x_2)$$

$$\Rightarrow \frac{y_1 - y_2}{x_1 - x_2} (y_1 + y_2) = 2 \Rightarrow \frac{1}{\sqrt{3}} (y_1 + y_2) = 2$$

$$\Rightarrow y_1 + y_2 = 2\sqrt{3} \Rightarrow \operatorname{Im}(z_1 + z_2) = 2\sqrt{3}$$

Hence, option (d) is correct.

2. (*) Given, $3|z_1| = 4|z_2| \Rightarrow \frac{|z_1|}{|z_2|} = \frac{4}{3} \quad [\because z_2 \neq 0 \Rightarrow |z_2| \neq 0]$

$$\therefore \frac{z_1}{z_2} = \frac{|z_1|}{|z_2|} e^{j\theta} \quad \text{and} \quad \frac{z_2}{z_1} = \frac{|z_2|}{|z_1|} e^{-i\theta}$$

$$[\because z = |z|(\cos \theta + i \sin \theta) = |z| e^{i\theta}]$$

$$\Rightarrow \frac{z_1}{z_2} = \frac{4}{3} e^{j\theta} \quad \text{and} \quad \frac{z_2}{z_1} = \frac{3}{4} e^{-i\theta}$$

$$\Rightarrow \frac{3}{2} \frac{z_1}{z_2} = 2e^{j\theta} \quad \text{and} \quad \frac{2}{3} \frac{z_2}{z_1} = \frac{1}{2} e^{-i\theta}$$

On adding these two, we get

$$z = \frac{3}{2} \frac{z_1}{z_2} + \frac{2}{3} \frac{z_2}{z_1} = 2e^{j\theta} + \frac{1}{2} e^{-i\theta}$$

$$= 2 \cos \theta + 2i \sin \theta + \frac{1}{2} \cos \theta - \frac{1}{2} i \sin \theta$$

$$[\because e^{\pm i\theta} = (\cos \theta \pm i \sin \theta)]$$

$$= \frac{5}{2} \cos \theta + \frac{3}{2} i \sin \theta$$

$$\Rightarrow |z| = \sqrt{\left(\frac{5}{2}\right)^2 + \left(\frac{3}{2}\right)^2} = \sqrt{\frac{34}{4}} = \sqrt{\frac{17}{2}}$$

Note that z is neither purely imaginary and nor purely real.

*None of the options is correct.

3. Given, $|z| = 1$, $\arg z = \theta \therefore z = e^{j\theta}$

$$\therefore \bar{z} = e^{-i\theta} \Rightarrow \bar{z} = \frac{1}{z}$$

$$\therefore \arg \left(\frac{1+z}{1+\bar{z}} \right) = \arg \left(\frac{1+z}{1+\frac{1}{z}} \right) = \arg(z) = \theta$$

4. Since, $\arg(z) < 0 \Rightarrow \arg(z) = -\theta$

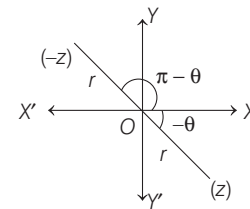

$$\Rightarrow z = r \cos(-\theta) + i \sin(-\theta)$$

$$= r(\cos \theta - i \sin \theta)$$

and $-z = -r[\cos \theta - i \sin \theta]$

$$= r[\cos(\pi - \theta) + i \sin(\pi - \theta)]$$

$$\therefore \arg(-z) = \pi - \theta$$

Thus, $\arg(-z) - \arg(z)$

$$= \pi - \theta - (-\theta) = \pi$$

Alternate Solution

Reason $\arg(-z) - \arg z = \arg\left(\frac{-z}{z}\right) = \arg(-1) = \pi$

and also $\arg z - \arg(-z) = \arg\left(\frac{z}{-z}\right) = \arg(-1) = \pi$

5. Given, $|z + iw| = |z - i\bar{w}| = 2$
 $\Rightarrow |z - (-iw)| = |z - (i\bar{w})| = 2$
 $\Rightarrow |z - (-iw)| = |z - (-i\bar{w})|$
 $\therefore z$ lies on the perpendicular bisector of the line joining $-iw$ and $-i\bar{w}$. Since, $-i\bar{w}$ is the mirror image of $-iw$ in the X-axis, the locus of z is the X-axis.
 Let $z = x + iy$ and $y = 0$.
 Now, $|z| \leq 1 \Rightarrow x^2 + 0^2 \leq 1$
 $\Rightarrow -1 \leq x \leq 1$.

$\therefore z$ may take values given in option (c).

Alternate Solution

- $$|z + iw| \leq |z| + |iw| = |z| + |w| \leq 1 + 1 = 2$$
- $\therefore |z + iw| \leq 2$
 $\Rightarrow |z + iw| = 2$ holds when $\arg z - \arg iw = 0$
 $\Rightarrow \arg \frac{z}{iw} = 0$
 $\Rightarrow \frac{z}{iw}$ is purely real.
 $\Rightarrow \frac{z}{w}$ is purely imaginary.

Similarly, when $|z - i\bar{w}| = 2$, then $\frac{z}{w}$ is purely imaginary

Now, given relation

- $$|z + iw| = |z - i\bar{w}| = 2$$
- Put $w = i$, we get
- $$|z + i^2| = |z + i^2| = 2$$
- $$\Rightarrow |z - 1| = 2$$
- $$\Rightarrow z = -1 \quad [\because |z| \leq 1]$$

Put $w = -i$, we get

- $$|z - i^2| = |z - i^2| = 2$$
- $$\Rightarrow |z + 1| = 2 \Rightarrow z = 1 \quad [\because |z| \leq 1]$$

$\therefore z = 1$ or -1 is the correct option.

6. Since, $|z| = |w|$ and $\arg(z) = \pi - \arg(w)$
 Let $w = re^{i\theta}$, then $\bar{w} = re^{-i\theta}$
 $\therefore z = re^{j(\pi - \theta)} = re^{i\pi} \cdot e^{-i\theta} = -re^{-i\theta} = -\bar{w}$
7. Given, $|z_1 + z_2| = |z_1| + |z_2|$
 On squaring both sides, we get
 $|z_1|^2 + |z_2|^2 + 2|z_1||z_2| \cos(\arg z_1 - \arg z_2) = |z_1|^2 + |z_2|^2 + 2|z_1||z_2|$
 $\Rightarrow 2|z_1||z_2| \cos(\arg z_1 - \arg z_2) = 2|z_1||z_2|$
 $\Rightarrow \cos(\arg z_1 - \arg z_2) = 1$
 $\Rightarrow \arg(z_1) - \arg(z_2) = 0$
8. Since a, b, c and u, v, w are the vertices of two triangles.
 Also, $c = (1 - r)a + rb$
 and $w = (1 - r)u + rv$... (i)

Consider $\begin{vmatrix} a & u & 1 \\ b & v & 1 \\ c & w & 1 \end{vmatrix}$

Applying $R_3 \rightarrow R_3 - \{(1 - r)R_1 + rR_2\}$

$$= \begin{vmatrix} a & u & 1 \\ b & v & 1 \\ c - (1 - r)a - rb & w - (1 - r)u - rv & 1 - (1 - r) - r \end{vmatrix}$$

$$= \begin{vmatrix} a & u & 1 \\ b & v & 1 \\ 0 & 0 & 0 \end{vmatrix} = 0 \quad \text{[from Eq. (i)]}$$

9. (a) Let $z = -1 - i$ and $\arg(z) = \theta$

Now, $\tan \theta = \left| \frac{\text{im}(z)}{\text{Re}(z)} \right| = \left| \frac{-1}{-1} \right| = 1$

$\Rightarrow \theta = \frac{\pi}{4}$

Since, $x < 0, y < 0$

$\therefore \arg(z) = -\left(\pi - \frac{\pi}{4}\right) = -\frac{3\pi}{4}$

- (b) We have, $f(t) = \arg(-1 + it)$

$$\arg(-1 + it) = \begin{cases} \pi - \tan^{-1} t, & t \geq 0 \\ -(\pi + \tan^{-1} t), & t < 0 \end{cases}$$

This function is discontinuous at $t = 0$.

- (c) We have,

$$\arg\left(\frac{z_1}{z_2}\right) = \arg(z_1) - \arg(z_2)$$

Now $\arg\left(\frac{z_1}{z_2}\right) = \arg(z_1) - \arg(z_2) + 2n\pi$

$\therefore \arg\left(\frac{z_1}{z_2}\right) - \arg(z_1) + \arg(z_2)$

$$= \arg(z_1) - \arg(z_2) + 2n\pi - \arg(z_1) + \arg(z_2) = 2n\pi$$

So, given expression is multiple of 2π .

- (d) We have, $\arg\left(\frac{(z - z_1)(z_2 - z_3)}{(z - z_3)(z_2 - z_1)}\right) = \pi$

$\Rightarrow \left(\frac{z - z_1}{z - z_3}\right)\left(\frac{z_2 - z_3}{z_2 - z_1}\right)$ is purely real

Thus, the points $A(z_1), B(z_2), C(z_3)$ and $D(z)$ taken in order would be concyclic if purely real.

Hence, it is a circle.

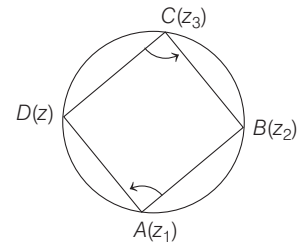

\therefore (a), (b), (d) are false statement.

20 Complex Numbers

10. Given, $z = \frac{(1-t)z_1 + tz_2}{(1-t) + t}$

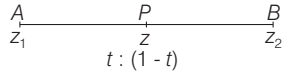

Clearly, z divides z_1 and z_2 in the ratio of $t:(1-t)$, $0 < t < 1$

$\Rightarrow AP + BP = AB$ i.e. $|z - z_1| + |z - z_2| = |z_1 - z_2|$

\Rightarrow Option (a) is true.

and $\arg(z - z_1) = \arg(z_2 - z) = \arg(z_2 - z_1)$

\Rightarrow Option (b) is false and option (d) is true.

Also, $\arg(z - z_1) = \arg(z_2 - z_1)$

$\Rightarrow \arg\left(\frac{z - z_1}{z_2 - z_1}\right) = 0$

$\therefore \frac{z - z_1}{z_2 - z_1}$ is purely real.

$\Rightarrow \frac{z - z_1}{z_2 - z_1} = \frac{\bar{z} - \bar{z}_1}{\bar{z}_2 - \bar{z}_1}$ or $\left| \frac{z - z_1}{z_2 - z_1} \right| = \left| \frac{\bar{z} - \bar{z}_1}{\bar{z}_2 - \bar{z}_1} \right| = 0$

Option (c) is correct.

11. Let $z = a + ib$.

Given, $\operatorname{Re}(z) = 0 \Rightarrow a = 0$

Then, $z = ib \Rightarrow z^2 = -b^2$ or $\operatorname{Im}(z^2) = 0$

Therefore, $A \rightarrow q$

Also, given, $\arg(z) = \frac{\pi}{4}$.

Let $z = r \left(\cos \frac{\pi}{4} + i \sin \frac{\pi}{4} \right)$

Then, $z^2 = r^2 \left(\cos^2 \frac{\pi}{4} - \sin^2 \frac{\pi}{4} \right) + 2ir^2 \cos \frac{\pi}{4} \sin \frac{\pi}{4}$
 $= ir^2 \sin \pi/2 = ir^2$

Therefore, $\operatorname{Re}(z^2) = 0 \Rightarrow B \rightarrow p$.

$\Rightarrow a = b = 2 - \sqrt{3}$ [$\because a, b \in (0, 1)$]

12. Let $z = r_1(\cos \theta_1 + i \sin \theta_1)$ and $w = r_2(\cos \theta_2 + i \sin \theta_2)$

We have, $|z| = r_1, |w| = r_2, \arg(z) = \theta_1$ and $\arg(w) = \theta_2$

Given, $|z| \leq 1, |w| < 1$

$\Rightarrow r_1 \leq 1$ and $r_2 \leq 1$

Now,

$$\begin{aligned} z - w &= (r_1 \cos \theta_1 - r_2 \cos \theta_2) + i(r_1 \sin \theta_1 - r_2 \sin \theta_2) \\ \Rightarrow |z - w|^2 &= (r_1 \cos \theta_1 - r_2 \cos \theta_2)^2 + (r_1 \sin \theta_1 - r_2 \sin \theta_2)^2 \\ &= r_1^2 \cos^2 \theta_1 + r_2^2 \cos^2 \theta_2 - 2r_1 r_2 \cos \theta_1 \cos \theta_2 \\ &\quad + r_1^2 \sin^2 \theta_1 + r_2^2 \sin^2 \theta_2 - 2r_1 r_2 \sin \theta_1 \sin \theta_2 \\ &= r_1^2 (\cos^2 \theta_1 + \sin^2 \theta_1) + r_2^2 (\cos^2 \theta_2 + \sin^2 \theta_2) \\ &\quad - 2r_1 r_2 (\cos \theta_1 \cos \theta_2 + \sin \theta_1 \sin \theta_2) \\ &= r_1^2 + r_2^2 - 2r_1 r_2 \cos(\theta_1 - \theta_2) \\ &= (r_1 - r_2)^2 + 2r_1 r_2 [1 - \cos(\theta_1 - \theta_2)] \\ &= (r_1 - r_2)^2 + 4r_1 r_2 \sin^2 \left(\frac{\theta_1 - \theta_2}{2} \right) \\ &\leq |r_1 - r_2|^2 + 4 \left| \sin \left(\frac{\theta_1 - \theta_2}{2} \right) \right|^2 \quad [\because r_1, r_2 \leq 1] \end{aligned}$$

and $|\sin \theta| \leq |\theta|, \forall \theta \in R$

Therefore, $|z - w|^2 \leq |r_1 - r_2|^2 + 4 \left| \frac{\theta_1 - \theta_2}{2} \right|^2$
 $\leq |r_1 - r_2|^2 + |\theta_1 - \theta_2|^2$
 $\Rightarrow |z - w|^2 \leq (|z| - |w|)^2 + (\arg z - \arg w)^2$

Alternate Solution

$$\begin{aligned} |z - w|^2 &= |z|^2 + |w|^2 - 2|z||w| \cos(\arg z - \arg w) \\ &= |z|^2 + |w|^2 - 2|z||w| + 2|z||w| \\ &\quad - 2|z||w| \cos(\arg z - \arg w) \\ &= (|z| - |w|)^2 + 2|z||w| \cdot 2 \sin^2 \left(\frac{\arg z - \arg w}{2} \right) \dots (i) \\ \therefore |z - w|^2 &\leq (|z| - |w|)^2 + 4 \cdot 1 \cdot 1 \left(\frac{\arg z - \arg w}{2} \right)^2 \\ &\quad [\because \sin \theta \leq \theta] \\ \Rightarrow |z - w|^2 &\leq (|z| - |w|)^2 + (\arg z - \arg w)^2 \end{aligned}$$

13. Since, $z_1 = 10 + 6i, z_2 = 4 + 6i$

and $\arg\left(\frac{z - z_1}{z - z_2}\right) = \frac{\pi}{4}$ represents locus of z is a circle

shown as from the figure whose centre is $(7, 9)$ and $\angle AOB = 90^\circ$, clearly $OC = 9 \Rightarrow OD = 6 + 3 = 9$

\therefore Centre = $(7, 9)$ and radius = $\frac{6}{\sqrt{2}} = 3\sqrt{2}$

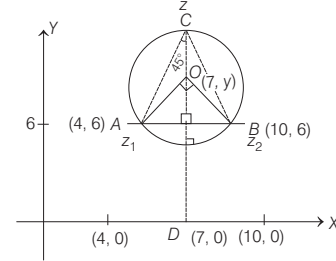

\Rightarrow Equation of circle is $|z - (7 + 9i)| = 3\sqrt{2}$

Topic 4 Rotation of a Complex Number

1. The complex number z satisfying $|z - 2 + i| \geq \sqrt{5}$, which represents the region outside the circle (including the circumference) having centre $(2, -1)$ and radius $\sqrt{5}$ units.

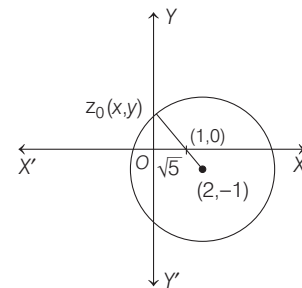

Now, for $z_0 \in S \frac{1}{|z_0 - 1|}$ is maximum.

When $|z_0 - 1|$ is minimum. And for this it is required that $z_0 \in S$, such that z_0 is collinear with the points $(2, -1)$ and $(1, 0)$ and lies on the circumference of the circle $|z - 2 + i| = \sqrt{5}$.

So let $z_0 = x + iy$, and from the figure $0 < x < 1$ and $y > 0$.

$$\begin{aligned} \text{So, } \frac{4 - z_0 - \bar{z}_0}{z_0 - \bar{z}_0 + 2i} &= \frac{4 - x - iy - x + iy}{x + iy - x + iy + 2i} \\ &= \frac{2(2-x)}{2i(y+1)} = -i \left(\frac{2-x}{y+1} \right) \end{aligned}$$

$\therefore \frac{2-x}{y+1}$ is a positive real number, so

$\frac{4 - z_0 - \bar{z}_0}{z_0 - \bar{z}_0 + 2i}$ is purely negative imaginary number.

$$\Rightarrow \arg \left(\frac{4 - z_0 - \bar{z}_0}{z_0 - \bar{z}_0 + 2i} \right) = -\frac{\pi}{2}$$

2. Given, $z = \left(\frac{\sqrt{3}}{2} + \frac{i}{2} \right)^5 + \left(\frac{\sqrt{3}}{2} - \frac{i}{2} \right)^5$

\therefore Euler's form of

$$\frac{\sqrt{3}}{2} + \frac{i}{2} = \left(\cos \frac{\pi}{6} + i \sin \frac{\pi}{6} \right) = e^{i\pi/6}$$

and $\frac{\sqrt{3}}{2} - \frac{i}{2} = \cos \left(-\frac{\pi}{6} \right) + i \sin \left(-\frac{\pi}{6} \right) = e^{-i\pi/6}$

$$\begin{aligned} \text{So, } z &= (e^{i\pi/6})^5 + (e^{-i\pi/6})^5 = e^{i\frac{5\pi}{6}} + e^{-i\frac{5\pi}{6}} \\ &= \left(\cos \frac{5\pi}{6} + i \sin \frac{5\pi}{6} \right) + \left(\cos \frac{5\pi}{6} - i \sin \frac{5\pi}{6} \right) \\ &= 2 \cos \frac{5\pi}{6} \quad [\because e^{i\theta} = \cos \theta + i \sin \theta] \end{aligned}$$

$\therefore I(z) = 0$ and $R(z) = -2 \cos \frac{\pi}{6} = -\sqrt{3} < 0$

$$\left[\because \cos \frac{5\pi}{6} = \cos \left(\pi - \frac{\pi}{6} \right) = -\cos \frac{\pi}{6} \right]$$

3.

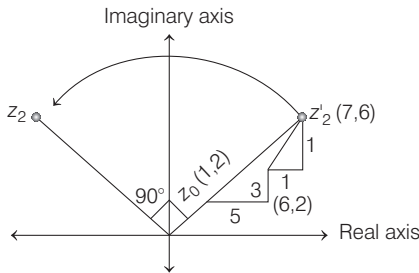

$$z_2' = (6 + \sqrt{2} \cos 45^\circ, 5 + \sqrt{2} \sin 45^\circ) = (7, 6) = 7 + 6i$$

By rotation about $(0, 0)$,

$$\frac{z_2}{z_2'} = e^{i\pi/2} \Rightarrow z_2 = z_2' \left(e^{i\frac{\pi}{2}} \right)$$

$$= (7 + 6i) \left(\cos \frac{\pi}{2} + i \sin \frac{\pi}{2} \right) = (7 + 6i)(i) = -6 + 7i$$

4. Let $OA = 3$, so that the complex number associated with A is $3e^{i\pi/4}$. If z is the complex number associated with P , then

$$\begin{aligned} \frac{z - 3e^{i\pi/4}}{0 - 3e^{i\pi/4}} &= \frac{4}{3} e^{-i\pi/2} = -\frac{4i}{3} \\ \Rightarrow 3z - 9e^{i\pi/4} &= 12ie^{i\pi/4} \Rightarrow z = (3 + 4i)e^{i\pi/4} \end{aligned}$$

5. Since, $|PQ| = |PS| = |PR| = 2$

\therefore Shaded part represents the external part of circle having centre $(-1, 0)$ and radius 2.

As we know equation of circle having centre z_0 and radius r , is $|z - z_0| = r$

$$\begin{aligned} \therefore |z - (-1 + 0i)| &> 2 \\ \Rightarrow |z + 1| &> 2 \end{aligned}$$

Also, argument of $z + 1$ with respect to positive direction of X -axis is $\pi/4$.

$$\therefore \arg(z + 1) \leq \frac{\pi}{4} \quad \dots(i)$$

and argument of $z + 1$ in anticlockwise direction is $-\pi/4$.

$$\therefore -\pi/4 \leq \arg(z + 1) \quad \dots(ii)$$

From Eqs. (i) and (ii),

$$|\arg(z + 1)| \leq \pi/4$$

6. In the Argand plane, P is represented by $e^{i\theta}$ and Q is represented by $e^{i(\alpha-\theta)}$

Now, rotation about a line with angle α is given by $e^\theta \rightarrow e^{(\alpha-\theta)}$. Therefore, Q is obtained from P by reflection in the line making an angle $\alpha/2$.

$$\begin{aligned} 7. \frac{z_1 - z_3}{z_2 - z_3} &= \frac{1 - i\sqrt{3}}{2} = \frac{(1 - i\sqrt{3})(1 + i\sqrt{3})}{2(1 + i\sqrt{3})} \\ &= \frac{1 - i^2 3}{2(1 + i\sqrt{3})} \\ &= \frac{4}{2(1 + i\sqrt{3})} = \frac{2}{1 + i\sqrt{3}} \end{aligned}$$

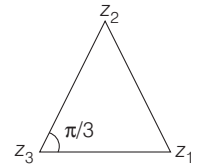

$$\begin{aligned} \Rightarrow \frac{z_2 - z_3}{z_1 - z_3} &= \frac{1 + i\sqrt{3}}{2} = \cos \frac{\pi}{3} + i \sin \frac{\pi}{3} \\ \Rightarrow \left| \frac{z_2 - z_3}{z_1 - z_3} \right| &= 1 \quad \text{and} \quad \arg \left(\frac{z_2 - z_3}{z_1 - z_3} \right) = \frac{\pi}{3} \end{aligned}$$

Hence, the triangle is an equilateral.

Alternate Solution

$$\begin{aligned} \therefore \frac{z_1 - z_3}{z_2 - z_3} &= \frac{1 - i\sqrt{3}}{2} \\ \Rightarrow \frac{z_2 - z_3}{z_1 - z_3} &= \frac{2}{1 - i\sqrt{3}} = \frac{1 + i\sqrt{3}}{2} = \cos \frac{\pi}{3} + i \sin \frac{\pi}{3} \\ \Rightarrow \arg \left(\frac{z_2 - z_3}{z_1 - z_3} \right) &= \frac{\pi}{3} \quad \text{and also} \quad \left| \frac{z_2 - z_3}{z_1 - z_3} \right| = 1 \end{aligned}$$

Therefore, triangle is equilateral.

8. Here, $x + iy = \frac{1}{a + ibt} \times \frac{a - ibt}{a - ibt}$

$$\therefore x + iy = \frac{a - ibt}{a^2 + b^2 t^2}$$

Let $a \neq 0, b \neq 0$

$$\therefore x = \frac{a}{a^2 + b^2 t^2} \quad \text{and} \quad y = \frac{-bt}{a^2 + b^2 t^2}$$

$$\Rightarrow \frac{y}{x} = \frac{-bt}{a} \Rightarrow t = \frac{ay}{bx}$$

22 Complex Numbers

On putting $x = \frac{a}{a^2 + b^2 t^2}$, we get

$$x \left(a^2 + b^2 \cdot \frac{a^2 y^2}{b^2 x^2} \right) = a \Rightarrow a^2(x^2 + y^2) = ax$$

or $x^2 + y^2 - \frac{x}{a} = 0 \quad \dots (i)$

or $\left(x - \frac{1}{2a}\right)^2 + y^2 = \frac{1}{4a^2}$

\therefore Option (a) is correct.

For $a \neq 0$ and $b = 0$,
 $x + iy = \frac{1}{a} \Rightarrow x = \frac{1}{a}, y = 0$

$\Rightarrow z$ lies on X-axis.

\therefore Option (c) is correct.

For $a = 0$ and $b \neq 0$, $x + iy = \frac{1}{ibt} \Rightarrow x = 0, y = -\frac{1}{bt}$

$\Rightarrow z$ lies on Y-axis.

\therefore Option (d) is correct.

9. **PLAN** It is the simple representation of points on Argand plane and to find the angle between the points.

Here, $P = W^n = \left(\cos \frac{\pi}{6} + i \sin \frac{\pi}{6} \right)^n = \cos \frac{n\pi}{6} + i \sin \frac{n\pi}{6}$

$$H_1 = \left\{ z \in C : \operatorname{Re}(z) > \frac{1}{2} \right\}$$

$\therefore P \cap H_1$ represents those points for which $\cos \frac{n\pi}{6}$ is +ve.

Hence, it belongs to I or IV quadrant.

$\Rightarrow z_1 = P \cap H_1 = \cos \frac{\pi}{6} + i \sin \frac{\pi}{6}$ or $\cos \frac{11\pi}{6} + i \sin \frac{11\pi}{6}$

$\therefore z_1 = \frac{\sqrt{3}}{2} + \frac{i}{2}$ or $\frac{\sqrt{3}}{2} - \frac{i}{2} \quad \dots (i)$

Similarly, $z_2 = P \cap H_2$ i.e. those points for which

$$\cos \frac{n\pi}{6} < 0$$

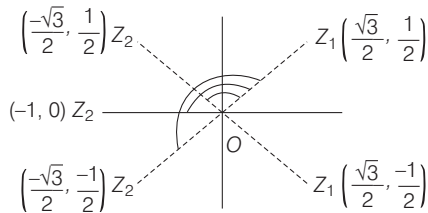

$\therefore z_2 = \cos \pi + i \sin \pi, \cos \frac{5\pi}{6} + i \sin \frac{5\pi}{6}, \cos \frac{7\pi}{6} + i \sin \frac{7\pi}{6}$

$\Rightarrow z_2 = -1, \frac{-\sqrt{3}}{2} + \frac{i}{2}, \frac{-\sqrt{3}}{2} - \frac{i}{2}$

Thus, $\angle z_1 O z_2 = \frac{2\pi}{3}, \frac{5\pi}{6}, \pi$

10. $z_1 = 1 + i\sqrt{3} = r(\cos \theta + i \sin \theta)$ [let]
 $\Rightarrow r \cos \theta = 1, r \sin \theta = \sqrt{3}$
 $\Rightarrow r = 2$ and $\theta = \pi/3$

So, $z_1 = 2(\cos \pi/3 + i \sin \pi/3)$

Since, $|z_2| = |z_3| = 2$ [given]

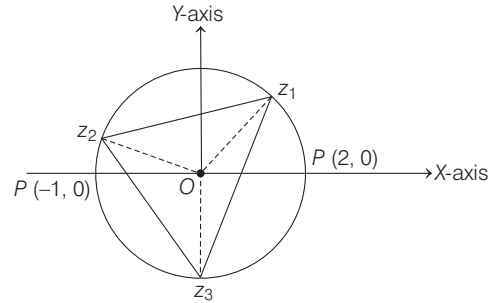

Now, the triangle z_1, z_2 and z_3 being an equilateral and the sides $z_1 z_2$ and $z_1 z_3$ make an angle $2\pi/3$ at the centre.

Therefore, $\angle P O z_2 = \frac{\pi}{3} + \frac{2\pi}{3} = \pi$

and $\angle P O z_3 = \frac{\pi}{3} + \frac{2\pi}{3} + \frac{2\pi}{3} = \frac{5\pi}{3}$

Therefore, $z_2 = 2(\cos \pi + i \sin \pi) = 2(-1 + 0) = -2$

and $z_3 = 2 \left(\cos \frac{5\pi}{3} + i \sin \frac{5\pi}{3} \right) = 2 \left(\frac{1}{2} - i \frac{\sqrt{3}}{2} \right) = 1 - i\sqrt{3}$

Alternate Solution

Whenever vertices of an equilateral triangle having centroid is given its vertices are of the form $z, z\omega, z\omega^2$.

\therefore If one of the vertex is $z_1 = 1 + i\sqrt{3}$, then other two vertices are $(z_1\omega), (z_1\omega^2)$.

$\Rightarrow (1 + i\sqrt{3}) \frac{(-1 + i\sqrt{3})}{2}, (1 + i\sqrt{3}) \frac{(-1 - i\sqrt{3})}{2}$

$\Rightarrow \frac{-(1+3)}{2}, \frac{-(1+i^2(\sqrt{3})^2 + 2i\sqrt{3})}{2}$

$\Rightarrow -2, \frac{-(-2 + 2i\sqrt{3})}{2} = 1 - i\sqrt{3}$

$\therefore z_2 = -2$ and $z_3 = 1 - i\sqrt{3}$

11. Given, $D = (1 + i), M = (2 - i)$

and diagonals of a rhombus bisect each other.

Let $B \equiv (a + ib)$, therefore

$$\frac{a+1}{2} = 2, \frac{b+1}{2} = -1 \Rightarrow a+1=4, b+1=-2$$

$\Rightarrow a=3, b=-3 \Rightarrow B \equiv (3-3i)$

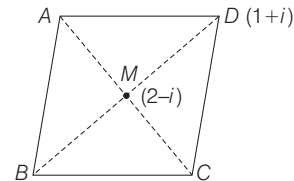

Again, $DM = \sqrt{(2-1)^2 + (-1-1)^2} = \sqrt{1+4} = \sqrt{5}$

But $BD = 2DM \Rightarrow BD = 2\sqrt{5}$

and $2AC = BD \Rightarrow 2AC = 2\sqrt{5}$

$\Rightarrow AC = \sqrt{5}$ and $AC = 2AM$

$\Rightarrow \sqrt{5} = 2AM \Rightarrow AM = \frac{\sqrt{5}}{2}$

Now, let coordinate of A be $(x + iy)$.

But in a rhombus $AD = AB$, therefore we have

$$\begin{aligned} AD^2 &= AB^2 \\ \Rightarrow (x-1)^2 + (y-1)^2 &= (x-3)^2 + (y+3)^2 \\ \Rightarrow x^2 + 1 - 2x + y^2 + 1 - 2y &= x^2 + 9 - 6x + y^2 + 9 + 6y \\ \Rightarrow 4x - 8y &= 16 \\ \Rightarrow x - 2y &= 4 \\ \Rightarrow x &= 2y + 4 \quad \dots(i) \end{aligned}$$

Again, $AM = \frac{\sqrt{5}}{2} \Rightarrow AM^2 = \frac{5}{4}$

$$\begin{aligned} \Rightarrow (x-2)^2 + (y+1)^2 &= \frac{5}{4} \\ \Rightarrow (2y+2)^2 + (y+1)^2 &= \frac{5}{4} \quad [\text{from Eq. (i)}] \\ \Rightarrow 5y^2 + 10y + 5 &= \frac{5}{4} \\ \Rightarrow 20y^2 + 40y + 15 &= 0 \\ \Rightarrow 4y^2 + 8y + 3 &= 0 \\ \Rightarrow (2y+1)(2y+3) &= 0 \\ \Rightarrow 2y+1=0, 2y+3 &= 0 \\ \Rightarrow y &= -\frac{1}{2}, y = -\frac{3}{2} \end{aligned}$$

On putting these values in Eq. (i), we get

$$\begin{aligned} x &= 2\left(-\frac{1}{2}\right) + 4, x = 2\left(-\frac{3}{2}\right) + 4 \\ \Rightarrow x &= 3, x = 1 \end{aligned}$$

Therefore, A is either $\left(3 - \frac{i}{2}\right)$ or $\left(1 - \frac{3i}{2}\right)$.

Alternate Solution

Since, M is the centre of rhombus.

∴ By rotating D about M through an angle of $\pm \pi/2$, we get possible position of A.

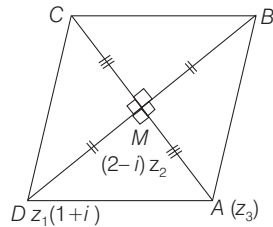

$$\begin{aligned} \Rightarrow \frac{z_3 - (2-i)}{-1+2i} &= \frac{1}{2} (\pm i) \Rightarrow \frac{z_3 - (2-i)}{-1+2i} = \frac{1}{2} (\pm i) \\ \Rightarrow z_3 &= (2-i) \pm \frac{1}{2} i(2i-1) = (2-i) \pm \frac{1}{2} (-2-i) \\ &= \frac{(4-2i-2-i)}{2}, \frac{4-2i+2+i}{2} = 1 - \frac{3}{2}i, 3 - \frac{i}{2} \\ \therefore A &\text{ is either } \left(1 - \frac{3}{2}i\right) \text{ or } \left(3 - \frac{i}{2}\right). \end{aligned}$$

12. Since, z_1, z_2 and z_3 form an equilateral triangle.

$$\begin{aligned} \Rightarrow z_1^2 + z_2^2 + z_3^2 &= z_1z_2 + z_2z_3 + z_3z_1 \\ \Rightarrow (a+i)^2 + (1+ib)^2 + (0)^2 &= (a+i)(1+ib) + 0 + 0 \\ \Rightarrow a^2 - 1 + 2ia + 1 - b^2 + 2ib &= a + i(ab+1) - b \\ \Rightarrow (a^2 - b^2) + 2i(a+b) &= (a-b) + i(ab+1) \\ \Rightarrow a^2 - b^2 &= a - b \end{aligned}$$

$$\begin{aligned} \text{and } 2(a+b) &= ab + 1 \\ \Rightarrow (a=b \text{ or } a+b=1) \\ \text{and } 2(a+b) &= ab + 1 \\ \text{If } a=b, 2(2a) &= a^2 + 1 \\ \Rightarrow a^2 - 4a + 1 &= 0 \\ \Rightarrow a &= \frac{4 \pm \sqrt{16-4}}{2} = 2 \pm \sqrt{3} \end{aligned}$$

If $a+b=1, 2=a(1-a)+1 \Rightarrow a^2 - a + 1 = 0$

$\Rightarrow a = \frac{1 \pm \sqrt{1-4}}{2}$, but a and $b \in R$

∴ Only solution when $a=b$
 $\Rightarrow a=b=2 \pm \sqrt{3}$
 $\Rightarrow a=b=2 - \sqrt{3}$ [$\because a, b \in (0, 1)$]

13. Here, centre of circle is $(1, 0)$ is also the mid-point of diagonals of square

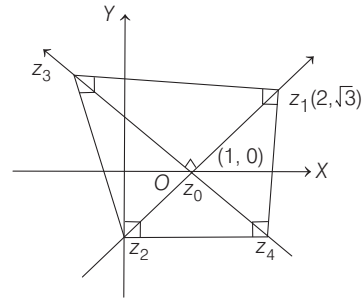

$$\begin{aligned} \Rightarrow \frac{z_1 + z_2}{2} &= z_0 \\ \Rightarrow z_2 &= -\sqrt{3}i \quad [\text{where, } z_0 = 1 + 0i] \\ \text{and } \frac{z_3 - 1}{z_1 - 1} &= e^{\pm i\pi/2} \\ \Rightarrow z_3 &= 1 + (1 + \sqrt{3}i) \cdot \left(\cos \frac{\pi}{2} \pm i \sin \frac{\pi}{2}\right) [\because z_1 = 2 + \sqrt{3}i] \\ &= 1 \pm i(1 + \sqrt{3}i) = (1 \mp \sqrt{3}) \pm i = (1 - \sqrt{3}) + i \\ \text{and } z_4 &= (1 + \sqrt{3}) - i \end{aligned}$$

14. Let Q be z_2 and its reflection be the point P(z_1) in the given line. If O(z) be any point on the given line then by definition OR is right bisector of QP.

$$\begin{aligned} \therefore OP &= OQ \text{ or } |z - z_1| = |z - z_2| \\ \Rightarrow |z - z_1|^2 &= |z - z_2|^2 \\ \Rightarrow (z - z_1)(\bar{z} - \bar{z}_1) &= (z - z_2)(\bar{z} - \bar{z}_2) \\ \Rightarrow z(\bar{z}_1 - \bar{z}_2) + \bar{z}(z_1 - z_2) &= z_1\bar{z}_1 - z_2\bar{z}_2 \end{aligned}$$

Comparing with given line $z\bar{b} + \bar{z}b = c$

$$\frac{\bar{z}_1 - \bar{z}_2}{b} = \frac{z_1 - z_2}{b} = \frac{z_1\bar{z}_1 - z_2\bar{z}_2}{c} = \lambda, \quad [\text{say}]$$

$$\frac{\bar{z}_1 - \bar{z}_2}{\lambda} = \bar{b}, \frac{z_1 - z_2}{\lambda} = b, \frac{z_1\bar{z}_1 - z_2\bar{z}_2}{\lambda} = c \quad \dots(i)$$

$$\begin{aligned} \therefore \bar{z}_1 b + z_2 \bar{b} &= \bar{z}_1 \left(\frac{z_1 - z_2}{\lambda}\right) + z_2 \left(\frac{\bar{z}_1 - \bar{z}_2}{\lambda}\right) \\ &= \frac{z\bar{z}_1 - z_2\bar{z}_2}{\lambda} = c \quad [\text{from Eq. (i)}] \end{aligned}$$

24 Complex Numbers

15. Since, $z_1 + z_2 = -p$ and $z_1 z_2 = q$

Now, $\frac{z_1}{z_2} = \frac{|z_1|}{|z_2|} (\cos \alpha + i \sin \alpha)$

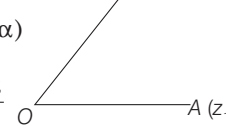
$\Rightarrow \frac{z_1}{z_2} = \frac{\cos \alpha + i \sin \alpha}{1}$ 

[$\because |z_1| = |z_2|$]

Applying componendo and dividendo, we get

$$\frac{z_1 + z_2}{z_1 - z_2} = \frac{\cos \alpha + i \sin \alpha + 1}{\cos \alpha + i \sin \alpha - 1}$$

$$= \frac{2 \cos^2(\alpha/2) + 2i \sin(\alpha/2) \cos(\alpha/2)}{-2 \sin^2(\alpha/2) + 2i \sin(\alpha/2) \cos(\alpha/2)}$$

$$= \frac{2 \cos(\alpha/2) [\cos(\alpha/2) + i \sin(\alpha/2)]}{2i \sin(\alpha/2) [\cos(\alpha/2) + i \sin(\alpha/2)]}$$

$$= \frac{\cot(\alpha/2)}{i} = -i \cot \alpha/2 \Rightarrow \frac{-p}{z_1 - z_2} = -i \cot(\alpha/2)$$

On squaring both sides, we get $\frac{p^2}{(z_1 - z_2)^2} = -\cot^2(\alpha/2)$

$$\Rightarrow \frac{p^2}{(z_1 + z_2)^2 - 4z_1 z_2} = -\cot^2(\alpha/2)$$

$$\Rightarrow \frac{p^2}{p^2 - 4q} = -\cot^2(\alpha/2)$$

$$\Rightarrow p^2 = -p^2 \cot^2(\alpha/2) + 4q \cot^2(\alpha/2)$$

$$\Rightarrow p^2(1 + \cot^2 \alpha/2) = 4q \cot^2(\alpha/2)$$

$$\Rightarrow p^2 \operatorname{cosec}^2(\alpha/2) = 4q \cot^2(\alpha/2) \Rightarrow p^2 = 4q \cos^2 \alpha/2$$

16. Since, triangle is a right angled isosceles triangle.

\therefore Rotating z_2 about z_3 in anti-clockwise direction through an angle of $\pi/2$, we get

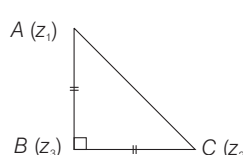
$$\frac{z_2 - z_3}{z_1 - z_3} = \frac{|z_2 - z_3|}{|z_1 - z_3|} e^{i\pi/2}$$

where, $|z_2 - z_3| = |z_1 - z_3|$

$$\Rightarrow (z_2 - z_3) = i(z_1 - z_3)$$

On squaring both sides, we get

$$(z_2 - z_3)^2 = -(z_1 - z_3)^2$$

$$\Rightarrow z_2^2 + z_3^2 - 2z_2 z_3 = -z_1^2 - z_3^2 + 2z_1 z_3$$

$$\Rightarrow z_1^2 + z_2^2 - 2z_1 z_2 = 2z_1 z_3 + 2z_2 z_3 - 2z_3^2 - 2z_1 z_2$$

$$\Rightarrow (z_1 - z_2)^2 = 2\{(z_1 z_3 - z_3^2) + (z_2 z_3 - z_1 z_2)\}$$

$$\Rightarrow (z_1 - z_2)^2 = 2(z_1 - z_3)(z_3 - z_2)$$

17. We have, $iz = ze^{i\pi/2}$. This implies that iz is the vector obtained by rotating vector z in anti-clockwise direction through 90° . Therefore, $OA \perp AB$. So,

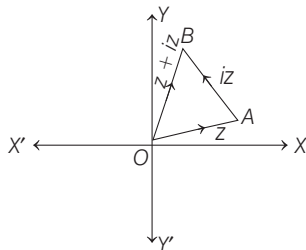

$$\text{Area of } \Delta OAB = \frac{1}{2} OA \times OB = \frac{1}{2} |z| |iz| = \frac{1}{2} |z|^2$$

18. Since, z_1, z_2 and origin form an equilateral triangle.

$$\left[\because \text{if } z_1, z_2, z_3 \text{ from an equilateral triangle, then } \right]$$

$$z_1^2 + z_2^2 + z_3^2 = z_1 z_2 + z_2 z_3 + z_3 z_1$$

$$\Rightarrow z_1^2 + z_2^2 + 0^2 = z_1 z_2 + z_2 \cdot 0 + 0 \cdot z_1$$

$$\Rightarrow z_1^2 + z_2^2 = z_1 z_2 \Rightarrow z_1^2 + z_2^2 - z_1 z_2 = 0$$

19. Since, z_1, z_2, z_3 are the vertices of an equilateral triangle.

$$\therefore \text{Circumcentre } (z_0) = \text{Centroid} \left(\frac{z_1 + z_2 + z_3}{3} \right) \quad \dots(i)$$

Also, for equilateral triangle

$$z_1^2 + z_2^2 + z_3^2 = z_1 z_2 + z_2 z_3 + z_3 z_1 \quad \dots(ii)$$

On squaring Eq. (i), we get

$$9z_0^2 = z_1^2 + z_2^2 + z_3^2 + 2(z_1 z_2 + z_2 z_3 + z_3 z_1)$$

$$\Rightarrow 9z_0^2 = z_1^2 + z_2^2 + z_3^2 + 2(z_1^2 + z_2^2 + z_3^2) \quad [\text{from Eq. (ii)}]$$

$$\Rightarrow 3z_0^2 = z_1^2 + z_2^2 + z_3^2$$

20. For a complex number z , it is given that

$$z^4 - |z|^4 = 4iz^2$$

$$\Rightarrow z^4 - z^2 \bar{z}^2 = 4iz^2$$

$$\Rightarrow z^2(z - \bar{z})(z + \bar{z}) = 4iz^2$$

So, either $z^2 = 0$ or $(z - \bar{z})(z + \bar{z}) = 4i$

Now, **Case-I**, if $z^2 = 0$ and $z = x + iy$

$$\text{So, } x^2 - y^2 + 2ixy = 0 \Rightarrow x^2 - y^2 = 0$$

$$\text{and } xy = 0 \Rightarrow x = y = 0$$

$\Rightarrow z = 0$, which is not possible according to given conditions.

Case-II, if $(z - \bar{z})(z + \bar{z}) = 4i$ and $z = x + iy$

$$\text{So, } (2iy)(2x) = 4i$$

$\Rightarrow xy = 1$ is an equation of rectangular hyperbola and for minimum value of $|z_1 - z_2|^2$, the z_1 and z_2 must be vertices of the rectangular hyperbola.

Therefore, $z_1 = 1 + i$ and $z_2 = -1 - i$

$$\therefore \text{Minimum value of } |z_1 - z_2|^2 = (1 + 1)^2 + (1 + 1)^2 = 4 + 4 = 8$$

21. Given, $\alpha_k = \cos\left(\frac{k\pi}{7}\right) + i \sin\left(\frac{k\pi}{7}\right)$

$$= \cos\left(\frac{2k\pi}{14}\right) + i \sin\left(\frac{2k\pi}{14}\right)$$

$\therefore \alpha_k$ are vertices of regular polygon having 14 sides.

Let the side length of regular polygon be a .

$$\therefore |\alpha_{k+1} - \alpha_k| = \text{length of a side of the regular polygon}$$

$$= a \quad \dots(i)$$

and $|\alpha_{4k-1} - \alpha_{4k-2}| = \text{length of a side of the regular polygon}$

$$= a \quad \dots(ii)$$

$$\therefore \frac{\sum_{k=1}^{12} |\alpha_{k+1} - \alpha_k|}{\sum_{k=1}^3 |\alpha_{4k-1} - \alpha_{4k-2}|} = \frac{12(a)}{3(a)} = 4$$

Topic 5 De-Moivre's Theorem, Cube Roots and nth Roots of Unity

1. Given expression

$$\begin{aligned} & \left(\frac{1 + \sin \frac{2\pi}{9} + i \cos \frac{2\pi}{9}}{1 + \sin \frac{2\pi}{9} - i \cos \frac{2\pi}{9}} \right)^3 \\ &= \left[\frac{\left(\sin^2 \frac{2\pi}{9} - i^2 \cos^2 \frac{2\pi}{9} \right) + \left(\sin \frac{2\pi}{9} + i \cos \frac{2\pi}{9} \right)}{1 + \sin \frac{2\pi}{9} - i \cos \frac{2\pi}{9}} \right]^3 \\ &= \left[\frac{\left(\sin \frac{2\pi}{9} + i \cos \frac{2\pi}{9} \right) \cdot \left\{ \sin \frac{2\pi}{9} - i \cos \frac{2\pi}{9} + 1 \right\}}{1 + \sin \frac{2\pi}{9} - i \cos \frac{2\pi}{9}} \right]^3 \\ &= \left(\sin \frac{2\pi}{9} + i \cos \frac{2\pi}{9} \right)^3 = \left(-i^2 \sin \frac{2\pi}{9} + i \cos \frac{2\pi}{9} \right)^3 \\ &= i^3 \left[\cos \frac{2\pi}{9} - i \sin \frac{2\pi}{9} \right]^3 \\ &= -i \left[\cos \left(-\frac{2\pi}{9} \right) + i \sin \left(-\frac{2\pi}{9} \right) \right]^3 \\ &= -i \left[\cos \frac{2\pi}{3} - i \sin \frac{2\pi}{3} \right] \end{aligned}$$

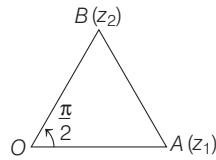

[according to the De-Moivre's theorem]

$$\begin{aligned} &= -i \left[\left(-\frac{1}{2} \right) - i \frac{\sqrt{3}}{2} \right] \\ &= -\frac{\sqrt{3}}{2} + \frac{i}{2} = -\frac{1}{2}(\sqrt{3} - i) \end{aligned}$$

2. It is given that, there are two complex numbers z and w , such that $|z w| = 1$ and $\arg(z) - \arg(w) = \pi/2$

$$\therefore |z||w| = 1 \quad [\because |z_1 z_2| = |z_1| |z_2|]$$

$$\text{and } \arg(z) = \frac{\pi}{2} + \arg(w)$$

$$\text{Let } |z| = r, \text{ then } |w| = \frac{1}{r} \quad \dots(\text{i})$$

$$\text{and let } \arg(w) = \theta, \text{ then } \arg(z) = \frac{\pi}{2} + \theta \quad \dots(\text{ii})$$

So, we can assume $z = r e^{i(\pi/2 + \theta)}$... (iii)

[\because if $z = x + iy$ is a complex number, then it can be written as $z = r e^{i\theta}$ where, $r = |z|$ and $\theta = \arg(z)$]

and $w = \frac{1}{r} e^{i\theta}$... (iv)

$$\begin{aligned} \text{Now, } \bar{z} \cdot w &= r e^{-i(\pi/2 + \theta)} \cdot \frac{1}{r} e^{i\theta} \\ &= e^{i(-\pi/2 - \theta + \theta)} = e^{-i(\pi/2)} = -i \quad [\because e^{-i\theta} = \cos \theta - i \sin \theta] \end{aligned}$$

$$\begin{aligned} \text{and } z \bar{w} &= r e^{i(\pi/2 + \theta)} \cdot \frac{1}{r} e^{-i\theta} \\ &= e^{i(\pi/2 + \theta - \theta)} = e^{i(\pi/2)} = i \end{aligned}$$

3. **Key Idea** Use, $e^{i\theta} = \cos \theta + i \sin \theta$

$$\text{Given, } z = \frac{\sqrt{3}}{2} + \left(\frac{1}{2} \right) i = \cos \frac{\pi}{6} + i \sin \frac{\pi}{6} = e^{i\frac{\pi}{6}}$$

$$\begin{aligned} \text{so, } (1 + iz + z^5 + iz^8)^9 &= \left(1 + i e^{i\frac{\pi}{6}} + e^{i\frac{5\pi}{6}} + i e^{i\frac{8\pi}{6}} \right)^9 \\ &= \left(1 + e^{i\frac{\pi}{2}} \cdot e^{i\frac{\pi}{6}} + e^{i\frac{5\pi}{6}} + e^{i\frac{\pi}{2}} \cdot e^{i\frac{4\pi}{3}} \right)^9 \quad \left[\because i = e^{i\frac{\pi}{2}} \right] \\ &= \left(1 + e^{i\frac{2\pi}{3}} + e^{i\frac{5\pi}{6}} + e^{i\frac{11\pi}{6}} \right)^9 \\ &= \left[1 + \left(\cos \frac{2\pi}{3} + i \sin \frac{2\pi}{3} \right) + \left(\cos \frac{5\pi}{6} + i \sin \frac{5\pi}{6} \right) \right. \\ &\quad \left. + \left(\cos \frac{11\pi}{6} + i \sin \frac{11\pi}{6} \right) \right]^9 \\ &= \left(1 - \frac{1}{2} + \frac{i\sqrt{3}}{2} - \frac{\sqrt{3}}{2} + \frac{1}{2} + \frac{i}{2} + \frac{\sqrt{3}}{2} - \frac{i}{2} \right)^9 \\ &= \left(\frac{1}{2} + \frac{\sqrt{3}i}{2} \right)^9 = \left(\cos \frac{\pi}{3} + i \sin \frac{\pi}{3} \right)^9 \\ &= \cos 3\pi + i \sin 3\pi \quad [\because \text{for any natural number 'n'} \\ &\quad (\cos \theta + i \sin \theta)^n = \cos(n\theta) + i \sin(n\theta)] \\ &= -1 \end{aligned}$$

4. Given, $x^2 + x + 1 = 0$

$$\Rightarrow x = \frac{-1 \pm \sqrt{3}i}{2}$$

[\because Roots of quadratic equation $ax^2 + bx + c = 0$

$$\text{are given by } x = \frac{-b \pm \sqrt{b^2 - 4ac}}{2a}]$$

$$\Rightarrow z_0 = \omega, \omega^2 \text{ [where } \omega = \frac{-1 + \sqrt{3}i}{2} \text{ and}$$

$$\omega^2 = \frac{-1 - \sqrt{3}i}{2}]$$

are the cube roots of unity and $\omega, \omega^2 \neq 1$

$$\begin{aligned} \text{Now consider } z &= 3 + 6i z_0^{81} - 3i z_0^{93} \\ &= 3 + 6i - 3i \quad (\because \omega^{3n} = (\omega^3)^n = 1) \\ &= 3 + 3i = 3(1 + i) \end{aligned}$$

If ' θ ' is the argument of z , then

$$\begin{aligned} \tan \theta &= \frac{\text{Im}(z)}{\text{Re}(z)} \quad [\because z \text{ is in the first quadrant}] \\ &= \frac{3}{3} = 1 \Rightarrow \theta = \frac{\pi}{4} \end{aligned}$$

5. Given that, $z = \cos \theta + i \sin \theta = e^{i\theta}$

$$\therefore \sum_{\mu=1}^{15} \text{Im}(\zeta^{2\mu-1}) = \sum_{\mu=1}^{15} \text{Im}(\epsilon^{i\theta})^{2\mu-1} = \sum_{\mu=1}^{15} \text{Im} \epsilon^{i(2\mu-1)\theta}$$

$$= \sin \theta + \sin 3\theta + \sin 5\theta + \dots + \sin 29\theta$$

26 Complex Numbers

$$\begin{aligned}
 &= \frac{\sin\left(\frac{\theta+29\theta}{2}\right)\sin\left(\frac{15\times 2\theta}{2}\right)}{\sin\left(\frac{2\theta}{2}\right)} \\
 &= \frac{\sin(15\theta)\sin(15\theta)}{\sin\theta} = \frac{1}{4\sin 2^\circ}
 \end{aligned}$$

6. Let $z = |a + b\omega + c\omega^2|$
 $\Rightarrow z^2 = |a + b\omega + c\omega^2|^2 = (a^2 + b^2 + c^2 - ab - bc - ca)$
 or $z^2 = \frac{1}{2} \{(a-b)^2 + (b-c)^2 + (c-a)^2\}$... (i)

Since, a, b, c are all integers but not all simultaneously equal.

\Rightarrow If $a = b$ then $a \neq c$ and $b \neq c$

Because difference of integers = integer

$\Rightarrow (b-c)^2 \geq 1$ {as minimum difference of two consecutive integers is (± 1) } also $(c-a)^2 \geq 1$

and we have taken $a = b \Rightarrow (a-b)^2 = 0$

From Eq. (i), $z^2 \geq \frac{1}{2}(0+1+1) \Rightarrow z^2 \geq 1$

Hence, minimum value of $|z|$ is 1.

7. Given, $(1 + \omega^2)^n = (1 + \omega^4)^n$
 $\Rightarrow (-\omega)^n = (-\omega^2)^n$ [$\because \omega^3 = 1$ and $1 + \omega + \omega^2 = 0$]
 $\Rightarrow \omega^n = 1$
 $\Rightarrow n = 3$ is the least positive value of n .

8. Let $\Delta = \begin{vmatrix} 1 & 1 & 1 \\ 1 & -1 - \omega^2 & \omega^2 \\ 1 & \omega^2 & \omega \end{vmatrix}$

Applying $R_2 \rightarrow R_2 - R_1; R_3 \rightarrow R_3 - R_1$

$$\begin{aligned}
 &= \begin{vmatrix} 1 & 1 & 1 \\ 0 & -2 - \omega^2 & \omega^2 - 1 \\ 0 & \omega^2 - 1 & \omega - 1 \end{vmatrix} \\
 &= (-2 - \omega^2)(\omega - 1) - (\omega^2 - 1)^2 \\
 &= -2\omega + 2 - \omega^3 + \omega^2 - (\omega^4 - 2\omega^2 + 1) \\
 &= 3\omega^2 - 3\omega = 3\omega(\omega - 1) \quad [\because \omega^4 = \omega]
 \end{aligned}$$

9. Since, $\arg \frac{z_1}{z_2} = \frac{\pi}{2}$
 $\Rightarrow \frac{z_1}{z_2} = \cos \frac{\pi}{2} + i \sin \frac{\pi}{2} = i$
 $\therefore \frac{z_1^n}{z_2^n} = (i)^n \Rightarrow i^n = 1$ [$\because |z_2| = |z_1| = 1$]
 $\Rightarrow n = 4k$

Alternate Solution

Since, $\arg \frac{z_2}{z_1} = \frac{\pi}{2}$

$$\therefore \frac{z_2}{z_1} = \left| \frac{z_2}{z_1} \right| e^{i\frac{\pi}{2}}$$

$$\Rightarrow \frac{z_2}{z_1} = i \quad [\because |z_1| = |z_2| = 1]$$

$$\Rightarrow \left(\frac{z_2}{z_1} \right)^n = i^n$$

$\therefore z_1$ and z_2 are n th roots of unity.

$$z_1^n = z_2^n = 1$$

$$\Rightarrow \left(\frac{z_2}{z_1} \right)^n = 1$$

$$\Rightarrow i^n = 1$$

$$\Rightarrow n = 4k, \text{ where } k \text{ is an integer.}$$

10. We know that,

$$\omega = -\frac{1}{2} + \frac{\sqrt{3}}{2}i$$

$$\begin{aligned}
 \therefore 4 + 5 \left(-\frac{1}{2} + \frac{i\sqrt{3}}{2} \right)^{334} + 3 \left(-\frac{1}{2} + \frac{i\sqrt{3}}{2} \right)^{365} \\
 &= 4 + 5\omega^{334} + 3\omega^{365} \\
 &= 4 + 5 \cdot (\omega^3)^{111} \cdot \omega + 3 \cdot (\omega^3)^{121} \cdot \omega^2 \\
 &= 4 + 5\omega + 3\omega^2 \quad [\because \omega^3 = 1] \\
 &= 1 + 3 + 2\omega + 3\omega + 3\omega^2 \\
 &= 1 + 2\omega + 3(1 + \omega + \omega^2) = 1 + 2\omega + 3 \times 0 \\
 &= 1 + (-1 + \sqrt{3}i) = \sqrt{3}i \quad [\because 1 + \omega + \omega^2 = 0]
 \end{aligned}$$

11. $(1 + \omega - \omega^2)^7 = (-\omega^2 - \omega^2)^7$ [$\because 1 + \omega + \omega^2 = 0$]
 $= (-2\omega^2)^7 = (-2)^7 \omega^{14} = -128\omega^2$

12. $(1 + \omega)^7 = (1 + \omega)(1 + \omega)^6$
 $= (1 + \omega)(-\omega^2)^6 = 1 + \omega$
 $\Rightarrow A + B\omega = 1 + \omega$
 $\Rightarrow A = 1, B = 1$

13. $\sum_{k=1}^6 \left(\sin \frac{2k\pi}{7} - i \cos \frac{2k\pi}{7} \right)$
 $= \sum_{k=1}^6 -i \left(\cos \frac{2k\pi}{7} + i \sin \frac{2k\pi}{7} \right)$
 $= -i \left\{ \sum_{k=1}^6 e^{\frac{i2k\pi}{7}} \right\} = -i \{ e^{i2\pi/7} + e^{i4\pi/7} + e^{i6\pi/7} + e^{i8\pi/7} + e^{i10\pi/7} + e^{i12\pi/7} \}$
 $= -i \left\{ e^{i2\pi/7} \frac{(1 - e^{i12\pi/7})}{1 - e^{i2\pi/7}} \right\}$
 $= -i \left\{ \frac{e^{j2\pi/7} - e^{j14\pi/7}}{1 - e^{i2\pi/7}} \right\}$ [$\because e^{i14\pi/7} = 1$]
 $= -i \left\{ \frac{e^{i2\pi/7} - 1}{1 - e^{i2\pi/7}} \right\} = i$

14. (P) PLAN $e^{i\theta} \cdot e^{i\alpha} = e^{i(\theta + \alpha)}$

$$\text{Given } z_k = e^{i\frac{2k\pi}{10}} \Rightarrow z_k \cdot z_j = e^{i\left(\frac{2\pi}{10}\right)(k+j)}$$

z_k is 10th root of unity.

$\Rightarrow \bar{z}_k$ will also be 10th root of unity.

Taking, z_j as \bar{z}_k , we have $z_k \cdot z_j = 1$ (True)

(Q) PLAN $\frac{e^{i\theta}}{e^{i\alpha}} = e^{i(\theta - \alpha)}$
 $z = z_k / z_1 = e^{i\left(\frac{2k\pi}{10} - \frac{2\pi}{10}\right)} = e^{i\frac{\pi}{5}(k-1)}$

For $k=2; z = e^{i\frac{\pi}{5}}$ which is in the given set (False)

(R) PLAN

(i) $1 - \cos 2\theta = 2 \sin^2 \theta$
 (ii) $\sin 2\theta = 2 \sin \theta \cos \theta$ and
 (i) $\cos 36^\circ = \frac{\sqrt{5} - 1}{4}$

(ii) $\cos 108^\circ = \frac{\sqrt{5} + 1}{4}$

NOTE $|1 - z_k| = \left| 1 - \cos \frac{2\pi k}{10} - i \sin \frac{2\pi k}{10} \right|$
 $= \left| 2 \sin \frac{\pi k}{10} \right| \left| \sin \frac{\pi k}{10} - i \cos \frac{\pi k}{10} \right| = 2 \left| \sin \frac{\pi k}{10} \right|$

Now, required product is

$$\frac{2^9 \sin \frac{\pi}{10} \cdot \sin \frac{2\pi}{10} \cdot \sin \frac{3\pi}{10} \dots \sin \frac{8\pi}{10} \cdot \sin \frac{9\pi}{10}}{10}$$

$$= \frac{2^9 \left(\sin \frac{\pi}{10} \sin \frac{2\pi}{10} \sin \frac{3\pi}{10} \sin \frac{4\pi}{10} \right)^2 \sin \frac{5\pi}{10}}{10}$$

$$= \frac{2^9 \left(\sin \frac{\pi}{10} \cos \frac{\pi}{10} \cdot \sin \frac{2\pi}{10} \cos \frac{2\pi}{10} \right)^2 \cdot 1}{10}$$

$$= \frac{2^9 \left(\frac{1}{2} \sin \frac{\pi}{5} \cdot \frac{1}{2} \sin \frac{2\pi}{5} \right)^2}{10}$$

$$= \frac{2^5 (\sin 36^\circ \cdot \sin 72^\circ)^2}{10}$$

$$= \frac{2^5}{2^2 \times 10} (2 \sin 36^\circ \sin 72^\circ)^2$$

$$= \frac{2^2}{5} (\cos 36^\circ - \cos 108^\circ)^2$$

$$= \frac{2^2}{5} \left[\left(\frac{\sqrt{5} - 1}{4} \right) + \left(\frac{\sqrt{5} + 1}{4} \right) \right]^2 = \frac{2^2 \cdot 5}{5 \cdot 4} = 1$$

(S) Sum of n th roots of unity = 0

$$1 + \alpha + \alpha^2 + \alpha^3 + \dots + \alpha^9 = 0$$

$$1 + \sum_{k=1}^9 \alpha^k = 0$$

$$1 + \sum_{k=1}^9 \left(\cos \frac{2k\pi}{10} + i \sin \frac{2k\pi}{10} \right) = 0$$

$$1 + \sum_{k=1}^9 \cos \frac{2k\pi}{10} = 0$$

So, $1 - \sum_{k=1}^9 \cos \frac{2k\pi}{10} = 2$

(P) \rightarrow (i), (Q) \rightarrow (ii), (R) \rightarrow (iii), (S) \rightarrow (iv)

15. Let $A = \begin{bmatrix} 1 & \omega & \omega^2 \\ \omega & \omega^2 & 1 \\ \omega^2 & 1 & \omega \end{bmatrix}$

Now, $A^2 = \begin{bmatrix} 0 & 0 & 0 \\ 0 & 0 & 0 \\ 0 & 0 & 0 \end{bmatrix}$ and $\text{Tr}(A) = 0, |A| = 0$

$A^3 = 0$

$\Rightarrow \begin{vmatrix} z+1 & \omega & \omega^2 \\ \omega & z+\omega^2 & 1 \\ \omega^2 & 1 & z+\omega \end{vmatrix} = [A + zI] = 0$

$\Rightarrow z^3 = 0$

$\Rightarrow z = 0$, the number of z satisfying the given equation is 1.

16. Here, $T_r = (r-1)(r-\omega)(r-\omega^2) = (r^3 - 1)$

$\therefore S_n = \sum_{r=1}^n (r^3 - 1)$
 $= \left[\frac{n(n+1)}{2} \right]^2 - n$

17. Since, cube root of unity are $1, \omega, \omega^2$ given by

$A(1,0), B\left(-\frac{1}{2}, -\frac{\sqrt{3}}{2}\right), C\left(-\frac{1}{2}, \frac{\sqrt{3}}{2}\right)$

$\Rightarrow AB = BC = CA = \sqrt{3}$

Hence, cube roots of unity form an equilateral triangle.

18. Given, $z^{p+q} - z^p - z^q + 1 = 0 \dots (i)$
 $\Rightarrow (z^p - 1)(z^q - 1) = 0$

Since, α is root of Eq. (i), either $\alpha^p - 1 = 0$ or $\alpha^q - 1 = 0$

\Rightarrow Either $\frac{\alpha^p - 1}{\alpha - 1} = 0$ or $\frac{\alpha^q - 1}{\alpha - 1} = 0$ [as $\alpha \neq 1$]

\Rightarrow Either $1 + \alpha + \alpha^2 + \dots + \alpha^{p-1} = 0$
 or $1 + \alpha + \dots + \alpha^{q-1} = 0$

But $\alpha^p - 1 = 0$ and $\alpha^q - 1 = 0$ cannot occur simultaneously as p and q are distinct primes, so neither p divides q nor q divides p , which is the requirement for $1 = \alpha^p = \alpha^q$.

19. Since, $1, \alpha_1, \alpha_2, \dots, \alpha_{n-1}$ are n th roots of unity.

$\Rightarrow (x^n - 1) = (x - 1)(x - \alpha_1)(x - \alpha_2) \dots (x - \alpha_{n-1})$

$\Rightarrow \frac{x^n - 1}{x - 1} = (x - \alpha_1)(x - \alpha_2) \dots (x - \alpha_{n-1})$

$\Rightarrow x^{n-1} + x^{n-2} + \dots + x^2 + x + 1$

$= (x - \alpha_1)(x - \alpha_2) \dots (x - \alpha_{n-1})$

$\left[\because \frac{x^n - 1}{x - 1} = x^{n-1} + x^{n-2} + \dots + x + 1 \right]$

On putting $x = 1$, we get $1 + 1 + \dots$ n times

$= (1 - \alpha_1)(1 - \alpha_2) \dots (1 - \alpha_{n-1})$

$\Rightarrow (1 - \alpha_1)(1 - \alpha_2) \dots (1 - \alpha_{n-1}) = n$

28 Complex Numbers

20. Since, n is not a multiple of 3, but odd integers and

$$x^3 + x^2 + x = 0 \Rightarrow x = 0, \omega, \omega^2$$

Now, when $x = 0$

$$\Rightarrow (x+1)^n - x^n - 1 = 1 - 0 - 1 = 0$$

$$\therefore x = 0 \text{ is root of } (x+1)^n - x^n - 1$$

Again, when $x = \omega$

$$\Rightarrow (x+1)^n - x^n - 1 = (1+\omega)^n - \omega^n - 1 \\ = -\omega^{2n} - \omega^n - 1 = 0$$

[as n is not a multiple of 3 and odd]

Similarly, $x = \omega^2$ is root of $\{(x+1)^n - x^n - 1\}$

Hence, $x = 0, \omega, \omega^2$ are the roots of $(x+1)^n - x^n - 1$

Thus, $x^3 + x^2 + x$ divides $(x+1)^n - x^n - 1$.

21. Since, α, β are the complex cube roots of unity.

\therefore We take $\alpha = \omega$ and $\beta = \omega^2$.

$$\text{Now, } xyz = (a+b)(a\alpha + b\beta)(a\beta + b\alpha)$$

$$= (a+b)[a^2\alpha\beta + ab(\alpha^2 + \beta^2) + b^2\alpha\beta]$$

$$= (a+b)[a^2(\omega \cdot \omega^2) + ab(\omega^2 + \omega^4) + b^2(\omega \cdot \omega^2)]$$

$$= (a+b)(a^2 - ab + b^2) \quad [:\because 1 + \omega + \omega^2 = 0 \text{ and } \omega^3 = 1]$$

$$= a^3 + b^3$$

22. Given, $\omega \neq 1$ be a cube root of unity, then $|a + b\omega + c\omega^2|^2$

$$= (a + b\omega + c\omega^2)(\overline{a + b\omega + c\omega^2}), (\because z\bar{z} = |z|^2)$$

$$= (a + b\omega + c\omega^2)(a + b\bar{\omega} + 2c\bar{\omega}^2)$$

$$= (a + b\omega + c\omega^2)(a + b\omega^2 + c\omega) \quad [:\because \bar{\omega} = \omega^2 \text{ and } \bar{\omega}^2 = \omega]$$

$$= a^2 + ab\omega^2 + ac\omega + ab\omega + b^2\omega^3 + bc\omega^2 + ac\omega^2 \\ + bc\omega^4 + c^2\omega^3$$

$$= a^2 + b^2 + c^2 + ab(\omega^2 + \omega) + bc(\omega^2 + \omega^4) + ac(\omega + \omega^2)$$

$$[\text{as } \omega^3 = 1]$$

$$= a^2 + b^2 + c^2 + ab(-1) + bc(-1) + ac(-1)$$

$$[\text{as } \omega + \omega^2 = -1, \omega^4 = \omega]$$

$$= a^2 + b^2 + c^2 - ab - bc - ca$$

$$= \frac{1}{2}\{(a-b)^2 + (b-c)^2 + (c-a)^2\}$$

$\therefore a, b$ and c are distinct non-zero integers.

For minimum value $a = 1, b = 2$ and $c = 3$

$$\therefore |a + b\omega + c\omega^2|_{\min}^2 = \frac{1}{2}\{1^2 + 1^2 + 2^2\}$$

$$= \frac{6}{2} = 3.00$$

23. Printing error = $e^{\frac{i2\pi}{3}}$

$$\text{Then, } \frac{|x|^2 + |y|^2 + |z|^2}{(a)^2 + (b)^2 + (c)^2} = 3$$

NOTE Here, $w = e^{\frac{i2\pi}{3}}$, then only integer solution exists.

2

Theory of Equations

Topic 1 Quadratic Equations

Objective Questions I (Only one correct option)

- Suppose a, b denote the distinct real roots of the quadratic polynomial $x^2 + 20x - 2020$ and suppose c, d denote the distinct complex roots of the quadratic polynomial $x^2 - 20x + 2020$. Then the value of $ac(a - c) + ad(a - d) + bc(b - c) + bd(b - d)$ is (2020 Adv.)
(a) 0 (b) 8000
(c) 8080 (d) 16000
- Let $\lambda \neq 0$ be in \mathbf{R} . If α and β are the roots of the equation, $x^2 - x + 2\lambda = 0$ and α and γ are the roots of the equation, $3x^2 - 10x + 27\lambda = 0$, then $\frac{\beta\gamma}{\lambda}$ is equal to (2020 Main, 4 Sep II)
(a) 36 (b) 9
(c) 27 (d) 18
- The set of all real values of λ for which the quadratic equations, $(\lambda^2 + 1)x^2 - 4\lambda x + 2 = 0$ always have exactly one root in the interval $(0, 1)$ is (2020 Main, 3 Sep II)
(a) $(0, 2)$ (b) $(-3, -1)$
(c) $(2, 4]$ (d) $(1, 3]$
- If α and β are the roots of the quadratic equation, $x^2 + x\sin\theta - 2\sin\theta = 0$, $\theta \in \left(0, \frac{\pi}{2}\right)$, then $\frac{\alpha^{12} + \beta^{12}}{(\alpha^{-12} + \beta^{-12})(\alpha - \beta)^{24}}$ is equal to (2019 Main, 10 April I)
(a) $\frac{2^{12}}{(\sin\theta + 8)^{12}}$ (b) $\frac{2^6}{(\sin\theta + 8)^{12}}$
(c) $\frac{2^{12}}{(\sin\theta - 4)^{12}}$ (d) $\frac{2^{12}}{(\sin\theta - 8)^6}$
- Let $p, q \in \mathbf{R}$. If $2 - \sqrt{3}$ is a root of the quadratic equation, $x^2 + px + q = 0$, then (2019 Main, 9 April I)
(a) $q^2 - 4p - 16 = 0$ (b) $p^2 - 4q - 12 = 0$
(c) $p^2 - 4q + 12 = 0$ (d) $q^2 + 4p + 14 = 0$
- If m is chosen in the quadratic equation $(m^2 + 1)x^2 - 3x + (m^2 + 1)^2 = 0$ such that the sum of its roots is greatest, then the absolute difference of the cubes of its roots is (2019 Main, 9 April II)
(a) $10\sqrt{5}$ (b) $8\sqrt{5}$ (c) $8\sqrt{3}$ (d) $4\sqrt{3}$

- If α and β are the roots of the equation $x^2 - 2x + 2 = 0$, then the least value of n for which $\left(\frac{\alpha}{\beta}\right)^n = 1$ is
(a) 2 (b) 5 (2019 Main, 8 April I)
(c) 4 (d) 3
- The number of integral values of m for which the equation $(1 + m^2)x^2 - 2(1 + 3m)x + (1 + 8m) = 0$, has no real root is (2019 Main, 8 April II)
(a) 3 (b) infinitely many
(c) 1 (d) 2
- The number of integral values of m for which the quadratic expression, $(1 + 2m)x^2 - 2(1 + 3m)x + 4(1 + m)$, $x \in \mathbf{R}$, is always positive, is (2019 Main, 12 Jan II)
(a) 6 (b) 8 (c) 7 (d) 3
- If λ be the ratio of the roots of the quadratic equation in x , $3m^2x^2 + m(m - 4)x + 2 = 0$, then the least value of m for which $\lambda + \frac{1}{\lambda} = 1$, is (2019 Main, 12 Jan I)
(a) $-2 + \sqrt{2}$ (b) $4 - 2\sqrt{3}$
(c) $4 - 3\sqrt{2}$ (d) $2 - \sqrt{3}$
- If one real root of the quadratic equation $81x^2 + kx + 256 = 0$ is cube of the other root, then a value of k is (2019 Main, 11 Jan I)
(a) 100 (b) 144 (c) -81 (d) -300
- If $5, 5r, 5r^2$ are the lengths of the sides of a triangle, then r cannot be equal to (2019 Main, 10 Jan I)
(a) $\frac{5}{4}$ (b) $\frac{7}{4}$ (c) $\frac{3}{2}$ (d) $\frac{3}{4}$
- The value of λ such that sum of the squares of the roots of the quadratic equation, $x^2 + (3 - \lambda)x + 2 = \lambda$ has the least value is (2019 Main, 10 Jan II)
(a) $\frac{4}{9}$ (b) 1 (c) $\frac{15}{8}$ (d) 2
- The number of all possible positive integral values of α for which the roots of the quadratic equation, $6x^2 - 11x + \alpha = 0$ are rational numbers is (2019 Main, 9 Jan II)
(a) 5 (b) 2 (c) 4 (d) 3

30 Theory of Equations

15. Let α and β be two roots of the equation $x^2 + 2x + 2 = 0$, then $\alpha^{15} + \beta^{15}$ is equal to (2019 Main, 9 Jan I)
 (a) 256 (b) 512
 (c) -256 (d) -512
16. Let $S = \{x \in \mathbf{R} : x \geq 0 \text{ and } 2|\sqrt{x} - 3| + \sqrt{x}(\sqrt{x} - 6) + 6 = 0\}$. Then, S (2018 Main)
 (a) is an empty set
 (b) contains exactly one element
 (c) contains exactly two elements
 (d) contains exactly four elements
17. If $\alpha, \beta \in \mathbf{C}$ are the distinct roots of the equation $x^2 - x + 1 = 0$, then $\alpha^{101} + \beta^{107}$ is equal to (2018 Main)
 (a) -1 (b) 0 (c) 1 (d) 2
18. For a positive integer n , if the quadratic equation, $x(x+1) + (x+1)(x+2) + \dots + (x+n-1)(x+n) = 10n$ has two consecutive integral solutions, then n is equal to (2017 Main)
 (a) 12 (b) 9 (c) 10 (d) 11
19. The sum of all real values of x satisfying the equation $(x^2 - 5x + 5)^{x^2 + 4x - 60} = 1$ is (2016 Main)
 (a) 3 (b) -4 (c) 6 (d) 5
20. Let $-\frac{\pi}{6} < \theta < -\frac{\pi}{12}$. Suppose α_1 and β_1 are the roots of the equation $x^2 - 2x \sec \theta + 1 = 0$, and α_2 and β_2 are the roots of the equation $x^2 + 2x \tan \theta - 1 = 0$. If $\alpha_1 > \beta_1$ and $\alpha_2 > \beta_2$, then $\alpha_1 + \beta_2$ equals (2016 Adv.)
 (a) $2(\sec \theta - \tan \theta)$ (b) $2 \sec \theta$
 (c) $-2 \tan \theta$ (d) 0
21. Let α and β be the roots of equation $x^2 - 6x - 2 = 0$. If $a_n = \alpha^n - \beta^n$, for $n \geq 1$, then the value of $\frac{a_{10} - 2a_8}{2a_9}$ is (2015 Main)
 (a) 6 (b) -6 (c) 3 (d) -3
22. In the quadratic equation $p(x) = 0$ with real coefficients has purely imaginary roots. Then, the equation $p[p(x)] = 0$ has (2014 Adv.)
 (a) only purely imaginary roots
 (b) all real roots
 (c) two real and two purely imaginary roots
 (d) neither real nor purely imaginary roots
23. Let α and β be the roots of equation $px^2 + qx + r = 0$, $p \neq 0$. If p, q and r are in AP and $\frac{1}{\alpha} + \frac{1}{\beta} = 4$, then the value of $|\alpha - \beta|$ is (2014 Main)
 (a) $\frac{\sqrt{61}}{9}$ (b) $\frac{2\sqrt{17}}{9}$
 (c) $\frac{\sqrt{34}}{9}$ (d) $\frac{2\sqrt{13}}{9}$
24. Let α and β be the roots of $x^2 - 6x - 2 = 0$, with $\alpha > \beta$. If $a_n = \alpha^n - \beta^n$ for $n \geq 1$, then the value of $\frac{a_{10} - 2a_8}{2a_9}$ is (2011)
 (a) 1 (b) 2 (c) 3 (d) 4
25. Let p and q be real numbers such that $p \neq 0, p^3 \neq q$ and $p^3 \neq -q$. If α and β are non-zero complex numbers satisfying $\alpha + \beta = -p$ and $\alpha^3 + \beta^3 = q$, then a quadratic equation having $\frac{\alpha}{\beta}$ and $\frac{\beta}{\alpha}$ as its roots is (2010)
 (a) $(p^3 + q)x^2 - (p^3 + 2q)x + (p^3 + q) = 0$
 (b) $(p^3 + q)x^2 - (p^3 - 2q)x + (p^3 + q) = 0$
 (c) $(p^3 - q)x^2 - (5p^3 - 2q)x + (p^3 - q) = 0$
 (d) $(p^3 - q)x^2 - (5p^3 + 2q)x + (p^3 - q) = 0$
26. Let α, β be the roots of the equation $x^2 - px + r = 0$ and $\frac{\alpha}{2}, 2\beta$ be the roots of the equation $x^2 - qx + r = 0$. Then, the value of r is (2007, 3M)
 (a) $\frac{2}{9}(p - q)(2q - p)$ (b) $\frac{2}{9}(q - p)(2p - q)$
 (c) $\frac{2}{9}(q - 2p)(2q - p)$ (d) $\frac{2}{9}(2p - q)(2q - p)$
27. If a, b, c are the sides of a triangle ABC such that $x^2 - 2(a + b + c)x + 3\lambda(ab + bc + ca) = 0$ has real roots, then (2006, 3M)
 (a) $\lambda < \frac{4}{3}$ (b) $\lambda > \frac{5}{3}$ (c) $\lambda \in \left(\frac{4}{3}, \frac{5}{3}\right)$ (d) $\lambda \in \left(\frac{1}{3}, \frac{5}{3}\right)$
28. If one root is square of the other root of the equation $x^2 + px + q = 0$, then the relation between p and q is (2004, 1M)
 (a) $p^3 - q(3p - 1) + q^2 = 0$
 (b) $p^3 - q(3p + 1) + q^2 = 0$
 (c) $p^3 + q(3p - 1) + q^2 = 0$
 (d) $p^3 + q(3p + 1) + q^2 = 0$
29. The set of all real numbers x for which $x^2 - |x + 2| + x > 0$ is (2002, 1M)
 (a) $(-\infty, -2) \cup (2, \infty)$ (b) $(-\infty, -\sqrt{2}) \cup (\sqrt{2}, \infty)$
 (c) $(-\infty, -1) \cup (1, \infty)$ (d) $(\sqrt{2}, \infty)$
30. The number of solutions of $\log_4(x - 1) = \log_2(x - 3)$ is (2001, 2M)
 (a) 3 (b) 1
 (c) 2 (d) 0
31. For the equation $3x^2 + px + 3 = 0, p > 0$, if one of the root is square of the other, then p is equal to (2000, 1M)
 (a) $1/3$ (b) 1 (c) 3 (d) $2/3$
32. If α and β ($\alpha < \beta$) are the roots of the equation $x^2 + bx + c = 0$, where $c < 0 < b$, then (2000, 1M)
 (a) $0 < \alpha < \beta$ (b) $\alpha < 0 < \beta < |\alpha|$
 (c) $\alpha < \beta < 0$ (d) $\alpha < 0 < |\alpha| < \beta$
33. The equation $\sqrt{x+1} - \sqrt{x-1} = \sqrt{4x-1}$ has (1997C, 2M)
 (a) no solution
 (b) one solution
 (c) two solutions
 (d) more than two solutions
34. The equation $x^{\frac{3}{4}(\log_2 x)^2 + \log_2 x - \frac{5}{4}} = \sqrt{2}$ has (1989; 2M)
 (a) atleast one real solution
 (b) exactly three real solutions
 (c) exactly one irrational solution
 (d) complex roots

35. If α and β are the roots of $x^2 + px + q = 0$ and α^4, β^4 are the roots of $x^2 - rx + s = 0$, then the equation $x^2 - 4qx + 2q^2 - r = 0$ has always (1989, 2M)
 (a) two real roots (b) two positive roots
 (c) two negative roots (d) one positive and one negative root
36. The equation $x - \frac{2}{x-1} = 1 - \frac{2}{x-1}$ has (1984, 2M)
 (a) no root (b) one root
 (c) two equal roots (d) infinitely many roots
37. For real x , the function $\frac{(x-a)(x-b)}{(x-c)}$ will assume all real values provided (1984, 3M)
 (a) $a > b > c$ (b) $a < b < c$ (c) $a > c < b$ (d) $a \leq c \leq b$
38. The number of real solutions of the equation $|x|^2 - 3|x| + 2 = 0$ is (1982, 1M)
 (a) 4 (b) 1 (c) 3 (d) 2
39. Both the roots of the equation $(x-b)(x-c) + (x-a)(x-c) + (x-a)(x-b) = 0$ are always (1980, 1M)
 (a) positive (b) negative
 (c) real (d) None of these
40. Let $a > 0, b > 0$ and $c > 0$. Then, both the roots of the equation $ax^2 + bx + c = 0$ (1979, 1M)
 (a) are real and negative (b) have negative real parts
 (c) have positive real parts (d) None of the above

Assertion and Reason

For the following question, choose the correct answer from the codes (a), (b), (c) and (d) defined as follows :

- (a) Statement I is true, Statement II is also true; Statement II is the correct explanation of Statement I
 (b) Statement I is true, Statement II is also true; Statement II is not the correct explanation of Statement I
 (c) Statement I is true; Statement II is false
 (d) Statement I is false; Statement II is true
41. Let a, b, c, p, q be the real numbers. Suppose α, β are the roots of the equation $x^2 + 2px + q = 0$. and $\alpha, \frac{1}{\beta}$ are the roots of the equation $ax^2 + 2bx + c = 0$, where $\beta^2 \notin \{-1, 0, 1\}$.
Statement I $(p^2 - q)(b^2 - ac) \geq 0$
Statement II $b \notin pa$ or $c \notin qa$. (2008, 3M)

Fill in the Blanks

42. The sum of all the real roots of the equation $|x-2|^2 + |x-2| - 2 = 0$ is..... (1997, 2M)
43. If the products of the roots of the equation $x^2 - 3kx + 2e^{2\log k} - 1 = 0$ is 7, then the roots are real for $k = \dots$ (1984, 2M)

44. If $2 + i\sqrt{3}$ is a root of the equation $x^2 + px + q = 0$, where p and q are real, then $(p, q) = (\dots, \dots)$. (1982, 2M)
45. The coefficient of x^{99} in the polynomial $(x-1)(x-2)\dots(x-100)$ is.... (1982, 2M)

True/False

46. If $P(x) = ax^2 + bx + c$ and $Q(x) = -ax^2 + bx + c$, where $ac \neq 0$, then $P(x)Q(x)$ has atleast two real roots. (1985, 1M)
47. The equation $2x^2 + 3x + 1 = 0$ has an irrational root. (1983, 1M)

Analytical & Descriptive Questions

48. If $x^2 - 10ax - 11b = 0$ have roots c and d . $x^2 - 10cx - 11d = 0$ have roots a and b , then find $a + b + c + d$. (2006, 6M)
49. If α, β are the roots of $ax^2 + bx + c = 0, (a \neq 0)$ and $\alpha + \delta, \beta + \delta$ are the roots of $Ax^2 + Bx + C = 0, (A \neq 0)$ for some constant δ , then prove that

$$\frac{b^2 - 4ac}{a^2} = \frac{B^2 - 4AC}{A^2}$$
 (2000, 4M)
50. Let $f(x) = Ax^2 + Bx + C$ where, A, B, C are real numbers. prove that if $f(x)$ is an integer whenever x is an integer, then the numbers $2A, A + B$ and C are all integers. Conversely, prove that if the numbers $2A, A + B$ and C are all integers, then $f(x)$ is an integer whenever x is an integer. (1998, 3M)
51. Find the set of all solutions of the equation
 $2^{|y|} - |2^{y-1} - 1| = 2^{y-1} + 1$ (1997 C, 3M)
52. Find the set of all x for which

$$\frac{2x}{2x^2 + 5x + 2} > \frac{1}{x+1}$$
 (1987, 3M)
53. Solve $|x^2 + 4x + 3| + 2x + 5 = 0$ (1987, 5M)
54. For $a \leq 0$, determine all real roots of the equation
 $x^2 - 2a|x-a| - 3a^2 = 0$ (1986, 5M)
55. Solve for $x: (5 + 2\sqrt{6})^{x^2-3} + (5 - 2\sqrt{6})^{x^2-3} = 10$ (1985, 5M)
56. If one root of the quadratic equation $ax^2 + bx + c = 0$ is equal to the n th power of the other, then show that

$$(ac^n)^{\frac{1}{n+1}} + (a^n c)^{\frac{1}{n+1}} + b = 0$$
 (1983, 2M)
57. If α and β are the roots of $x^2 + px + q = 0$ and γ, δ are the roots of $x^2 + rx + s = 0$, then evaluate $(\alpha - \gamma)(\beta - \gamma)(\alpha - \delta)(\beta - \delta)$ in terms of p, q, r and s . (1979, 2M)
58. Solve $2 \log_x a + \log_{ax} a + 3 \log_b a = 0$, where $a > 0, b = a^2 x$ (1978, 3M)
59. If α and β are the roots of the equation $x^2 + px + 1 = 0$; γ, δ are the roots of $x^2 + qx + 1 = 0$, then $q^2 - p^2 = (\alpha - \gamma)(\beta - \gamma)(\alpha + \delta)(\beta + \delta)$ (1978, 2M)

32 Theory of Equations

Passage Type Questions

Let p, q be integers and let α, β be the roots of the equation, $x^2 - x - 1 = 0$ where $\alpha \neq \beta$. For $n = 0, 1, 2, \dots$, let $a_n = p\alpha^n + q\beta^n$.

FACT: If a and b are rational numbers and $a + b\sqrt{5} = 0$, then $a = 0 = b$. (2017 Adv.)

60. $a_{12} =$
- (a) $a_{11} + 2a_{10}$ (b) $2a_{11} + a_{10}$
(c) $a_{11} - a_{10}$ (d) $a_{11} + a_{10}$
61. If $a_4 = 28$, then $p + 2q =$
- (a) 14 (b) 7
(c) 21 (d) 12

Topic 2 Common Roots

Objective Questions I (Only one correct option)

1. If α, β and γ are three consecutive terms of a non-constant GP such that the equations $\alpha x^2 + 2\beta x + \gamma = 0$ and $x^2 + x - 1 = 0$ have a common root, then, $\alpha(\beta + \gamma)$ is equal to (2019 Main, 12 April II)
- (a) 0
(b) $\alpha\beta$
(c) $\alpha\gamma$
(d) $\beta\gamma$
2. If the equations $x^2 + 2x + 3 = 0$ and $ax^2 + bx + c = 0$, $a, b, c \in R$ have a common root, then $a : b : c$ is
- (a) 1 : 2 : 3 (b) 3 : 2 : 1 (2013 Main)
(c) 1 : 3 : 2 (d) 3 : 1 : 2

3. A value of b for which the equations $x^2 + bx - 1 = 0$, $x^2 + x + b = 0$ have one root in common is (2011)
- (a) $-\sqrt{2}$ (b) $-i\sqrt{3}$ (c) $i\sqrt{5}$ (d) $\sqrt{2}$

Fill in the Blanks

4. If the quadratic equations $x^2 + ax + b = 0$ and $x^2 + bx + a = 0$ ($a \neq b$) have a common root, then the numerical value of $a + b$ is... (1986, 2M)

True/False

5. If $x - r$ is a factor of the polynomial $f(x) = a_n x^n + a_{n-1} x^{n-1} + \dots + a_0$ repeated m times ($1 < m \leq n$), then r is a root of $f'(x) = 0$ repeated m times. (1983, 1M)

Topic 3 Transformation of Roots

Objective Question I (Only one correct option)

1. Let α, β be the roots of the equation, $(x - a)(x - b) = c, c \neq 0$. Then the roots of the equation $(x - \alpha)(x - \beta) + c = 0$ are
- (a) a, c (b) b, c (c) a, b (d) $a + c, b + c$ (1992, 2M)

Analytical & Descriptive Question

2. Let a, b and c be real numbers with $a \neq 0$ and let α, β be the roots of the equation $ax^2 + bx + c = 0$. Express the roots of $a^3 x^2 + abcx + c^3 = 0$ in terms of α, β . (2001, 4M)

Topic 4 Graph of Quadratic Expression

Objective Questions I (Only one correct option)

1. Let $P(4, -4)$ and $Q(9, 6)$ be two points on the parabola, $y^2 = 4x$ and let X be any point on the arc POQ of this parabola, where O is the vertex of this parabola, such that the area of ΔPXQ is maximum. Then, this maximum area (in sq units) is (2019 Main, 12 Jan I)
- (a) $\frac{125}{2}$ (b) $\frac{75}{2}$
(c) $\frac{625}{4}$ (d) $\frac{125}{4}$
2. Consider the quadratic equation, $(c - 5)x^2 - 2cx + (c - 4) = 0, c \neq 5$. Let S be the set of all integral values of c for which one root of the equation lies in the interval $(0, 2)$ and its other root lies in the interval $(2, 3)$. Then, the number of elements in S is (2019 Main, 10 Jan I)
- (a) 11 (b) 10
(c) 12 (d) 18
3. If both the roots of the quadratic equation $x^2 - mx + 4 = 0$ are real and distinct and they lie in the interval $[1, 5]$ then m lies in the interval (2019 Main, 9 Jan II)
- (a) $(4, 5)$ (b) $(-5, -4)$
(c) $(5, 6)$ (d) $(3, 4)$
4. If $a \in R$ and the equation $-3(x - [x])^2 + 2(x - [x]) + a^2 = 0$ (where, $[x]$ denotes the greatest integer $\leq x$) has no integral solution, then all possible values of a lie in the interval (2014 Main)
- (a) $(-1, 0) \cup (0, 1)$ (b) $(1, 2)$
(c) $(-2, -1)$ (d) $(-\infty, -2) \cup (2, \infty)$
5. For all ' x ', $x^2 + 2ax + (10 - 3a) > 0$, then the interval in which ' a ' lies is (2004, 1M)
- (a) $a < -5$ (b) $-5 < a < 2$ (c) $a > 5$ (d) $2 < a < 5$

6. If $b > a$, then the equation $(x - a)(x - b) - 1 = 0$ has
 (a) both roots in (a, b) (2000, 1M)
 (b) both roots in $(-\infty, a)$
 (c) both roots in $(b, +\infty)$
 (d) one root in $(-\infty, a)$ and the other in (b, ∞)
7. If the roots of the equation $x^2 - 2ax + a^2 + a - 3 = 0$ are real and less than 3, then (1999, 2M)
 (a) $a < 2$
 (b) $2 \leq a \leq 3$
 (c) $3 < a \leq 4$
 (d) $a > 4$
8. Let $f(x)$ be a quadratic expression which is positive for all real values of x . If $g(x) = f(x) + f'(x) + f''(x)$, then for any real x (1990, 2M)
 (a) $g(x) < 0$ (b) $g(x) > 0$
 (c) $g(x) = 0$ (d) $g(x) \geq 0$

Topic 5 Some Special Forms

Objective Questions I (Only one correct option)

1. The number of real roots of the equation $5 + |2^x - 1| = 2^x(2^x - 2)$ is (2019 Main, 10 April II)
 (a) 1 (b) 3
 (c) 4 (d) 2
2. All the pairs (x, y) that satisfy the inequality $2\sqrt{\sin^2 x - 2\sin x + 5} \cdot \frac{1}{4^{\sin^2 y}} \leq 1$ also satisfy the equation (2019 Main, 10 April I)
 (a) $2|\sin x| = 3 \sin y$ (b) $\sin x = |\sin y|$
 (c) $\sin x = 2 \sin y$ (d) $2 \sin x = \sin y$
3. The sum of the solutions of the equation $|\sqrt{x} - 2| + \sqrt{x}(\sqrt{x} - 4) + 2 = 0$ ($x > 0$) is equal to (2019 Main, 8 April I)
 (a) 9 (b) 12
 (c) 4 (d) 10
4. The real number k for which the equation, $2x^3 + 3x + k = 0$ has two distinct real roots in $[0, 1]$ (2013 Main)
 (a) lies between 1 and 2 (b) lies between 2 and 3
 (c) lies between -1 and 0 (d) does not exist
5. Let a, b, c be real numbers, $a \neq 0$. If α is a root of $a^2x^2 + bx + c = 0$, β is the root of $a^2x^2 - bx - c = 0$ and $0 < \alpha < \beta$, then the equation $a^2x^2 + 2bx + 2c = 0$ has a root γ that always satisfies (1989, 2M)
 (a) $\gamma = \frac{\alpha + \beta}{2}$ (b) $\gamma = \alpha + \frac{\beta}{2}$
 (c) $\gamma = \alpha$ (d) $\alpha < \gamma < \beta$
6. If $a + b + c = 0$, then the quadratic equation $3ax^2 + 2bx + c = 0$ has (1983, 1M)
 (a) at least one root in $(0, 1)$
 (b) one root in $(2, 3)$ and the other in $(-2, -1)$
 (c) imaginary roots
 (d) None of the above

Analytical & Descriptive Questions

9. If $x^2 + (a - b)x + (1 - a - b) = 0$ where $a, b \in R$, then find the values of a for which equation has unequal real roots for all values of b . (2003, 4M)
10. Let a, b, c be real. If $ax^2 + bx + c = 0$ has two real roots α and β , where $\alpha < -1$ and $\beta > 1$, then show that $1 + \frac{c}{a} + \left| \frac{b}{a} \right| < 0$ (1995, 5M)
11. Find all real values of x which satisfy $x^2 - 3x + 2 > 0$ and $x^2 - 2x - 4 \leq 0$. (1983, 2M)

Integer & Numerical Answer Type Question

12. The smallest value of k , for which both the roots of the equation $x^2 - 8kx + 16(k^2 - k + 1) = 0$ are real, distinct and have values atleast 4, is (2009)

7. The largest interval for which $x^{12} - x^9 + x^4 - x + 1 > 0$ is (1982, 2M)
 (a) $-4 < x \leq 0$
 (b) $0 < x < 1$
 (c) $-100 < x < 100$
 (d) $-\infty < x < \infty$

8. Let a, b, c be non-zero real numbers such that

$$\int_0^1 (1 + \cos^8 x)(ax^2 + bx + c) dx = \int_0^2 (1 + \cos^8 x)(ax^2 + bx + c) dx$$
 (1981, 2M)

Then, the quadratic equation $ax^2 + bx + c = 0$ has

- (a) no root in $(0, 2)$
 (b) atleast one root in $(1, 2)$
 (c) a double root in $(0, 2)$
 (d) two imaginary roots

Objective Questions II

(One or more than one correct option)

9. Let S be the set of all non-zero real numbers α such that the quadratic equation $\alpha x^2 - x + \alpha = 0$ has two distinct real roots x_1 and x_2 satisfying the inequality $|x_1 - x_2| < 1$. Which of the following interval(s) is/are a subset of S ? (2015 Adv.)
 (a) $\left(-\frac{1}{2}, -\frac{1}{\sqrt{5}}\right)$ (b) $\left(-\frac{1}{\sqrt{5}}, 0\right)$
 (c) $\left(0, \frac{1}{\sqrt{5}}\right)$ (d) $\left(\frac{1}{\sqrt{5}}, \frac{1}{2}\right)$
10. Let $a \in R$ and $f: R \rightarrow R$ be given by $f(x) = x^5 - 5x + a$. Then,
 (a) $f(x)$ has three real roots, if $a > 4$
 (b) $f(x)$ has only one real root, if $a > 4$
 (c) $f(x)$ has three real roots, if $a < -4$
 (d) $f(x)$ has three real roots, if $-4 < a < 4$

34 Theory of Equations

Passage Based Problems

Read the following passage and answer the questions.

Passage I

Consider the polynomial $f(x) = 1 + 2x + 3x^2 + 4x^3$. Let s be the sum of all distinct real roots of $f(x)$ and let $t = |s|$.

(2010)

11. The real numbers s lies in the interval
 (a) $\left(-\frac{1}{4}, 0\right)$ (b) $\left(-11, -\frac{3}{4}\right)$ (c) $\left(-\frac{3}{4}, -\frac{1}{2}\right)$ (d) $\left(0, \frac{1}{4}\right)$
12. The area bounded by the curve $y = f(x)$ and the lines $x = 0, y = 0$ and $x = t$, lies in the interval
 (a) $\left(\frac{3}{4}, 3\right)$ (b) $\left(\frac{21}{64}, \frac{11}{16}\right)$ (c) $(9, 10)$ (d) $\left(0, \frac{21}{64}\right)$
13. The function $f'(x)$ is
 (a) increasing in $\left(-t, -\frac{1}{4}\right)$ and decreasing in $\left(-\frac{1}{4}, t\right)$
 (b) decreasing in $\left(-t, -\frac{1}{4}\right)$ and increasing in $\left(-\frac{1}{4}, t\right)$
 (c) increasing in $(-t, t)$
 (d) decreasing in $(-t, t)$

Passage II

If a continuous function f defined on the real line \mathbb{R} , assumes positive and negative values in \mathbb{R} , then the equation $f(x) = 0$ has a root in \mathbb{R} . For example, if it is known that a continuous function f on \mathbb{R} is positive at some point and its minimum values is negative, then the

equation $f(x) = 0$ has a root in \mathbb{R} . Consider $f(x) = ke^x - x$ for all real x where k is real constant. (2007, 4M)

14. The line $y = x$ meets $y = ke^x$ for $k \leq 0$ at
 (a) no point
 (b) one point
 (c) two points
 (d) more than two points
15. The positive value of k for which $ke^x - x = 0$ has only one root is
 (a) $\frac{1}{e}$ (b) 1
 (c) e (d) $\log_e 2$
16. For $k > 0$, the set of all values of k for which $ke^x - x = 0$ has two distinct roots, is
 (a) $\left(0, \frac{1}{e}\right)$ (b) $\left(\frac{1}{e}, 1\right)$
 (c) $\left(\frac{1}{e}, \infty\right)$ (d) $(0, 1)$

True/False

17. If $a < b < c < d$, then the roots of the equation $(x-a)(x-c) + 2(x-b)(x-d) = 0$ are real and distinct.

(1984, 1M)

Analytical & Descriptive Question

18. Let $-1 \leq p < 1$. Show that the equation $4x^3 - 3x - p = 0$ has a unique root in the interval $[1/2, 1]$ and identify it.

(2001, 4M)

Answers

Topic 1

- | | | | |
|-------------------------------------|---|----------------------------------|--|
| 1. (d) | 2. (d) | 3. (d) | 4. (a) |
| 5. (b) | 6. (b) | 7. (c) | 8. (a) |
| 9. (c) | 10. (c) | 11. (d) | 12. (b) |
| 13. (d) | 14. (d) | 15. (c) | 16. (c) |
| 17. (c) | 18. (d) | 19. (a) | 20. (c) |
| 21. (c) | 22. (d) | 23. (d) | 24. (c) |
| 25. (b) | 26. (d) | 27. (a) | 28. (a) |
| 29. (b) | 30. (b) | 31. (c) | 32. (b) |
| 33. (a) | 34. (b) | 35. (a) | 36. (a) |
| 37. (d) | 38. (a) | 39. (c) | 40. (b) |
| 41. (b) | 42. 4 | 43. $k = 2$ | 44. $(-4, 7)$ |
| 45. -5050 | 46. True | 47. False | 48. 1210 |
| 51. $y \in \{-1\} \cup [1, \infty)$ | 52. $x \in (-2, -1) \cup \left(-\frac{2}{3}, -\frac{1}{2}\right)$ | 53. -4 and $(-1 - \sqrt{3})$ | 54. $x = \{a(1 - \sqrt{2}), a(\sqrt{6} - 1)\}$ |
| 55. $\pm 2, \pm \sqrt{2}$ | 57. $(q-s)^2 - rqp - rsp + sp^2 + qr^2$ | 58. $x = a^{-1/2}$ or $a^{-4/3}$ | 59. $q^2 - p^2$ 60. (d) |
| 61. (d) | | | |

Topic 2

1. (d) 2. (a) 3. (b) 4. -1
 5. False

Topic 3

1. (c) 2. $x = \alpha^2\beta, \alpha\beta^2$

Topic 4

1. (d) 2. (a) 3. (a) 4. (a)
 5. (b) 6. (d) 7. (a) 8. (b)
 9. $a > 1$ 11. $x \in [1 - \sqrt{5}, 1) \cup [1 + \sqrt{5}, 2)$
 12. $k = 2$

Topic 5

1. (a) 2. (b) 3. (d) 4. (d)
 5. (d) 6. (a) 7. (d) 8. (b)
 9. (a,d) 10. (b, d) 11. (c) 12. (a)
 13. (b) 14. (b) 15. (a) 16. (a)
 17. True 18. $x = \cos \left[\frac{1}{3} \cos^{-1} p \right]$

Hints & Solutions

Topic 1 Quadratic Equations

1. Given quadratic polynomials, $x^2 + 20x - 2020$ and $x^2 - 20x + 2020$ having a, b distinct real and c, d distinct complex roots respectively.

So, $a + b = -20, ab = -2020$

and $c + d = 20, cd = 2020$

Now, $ac(a - c) + ad(a - d) + bc(b - c) + bd(b - d)$
 $= a^2(c + d) - a(c^2 + d^2) + b^2(c + d) - b(c^2 + d^2)$
 $= (c + d)(a^2 + b^2) - (c^2 + d^2)(a + b)$
 $= (c + d)[(a + b)^2 - 2ab] - (a + b)[(c + d)^2 - 2cd]$
 $= 20 [(20)^2 + 4040] + 20 [(20)^2 - 4040]$
 $= 2 \times 20 \times (20)^2 = 40 \times 400 = 16000$

2. It is given that α is a common roots of given quadratic equations

$$x^2 - x + 2\lambda = 0 \text{ and } 3x^2 - 10x + 27\lambda = 0$$

$$\therefore 3\alpha^2 - 10\alpha + 27\lambda = 0$$

$$3\alpha^2 - 3\alpha + 6\lambda = 0$$

$$\begin{array}{r} - \quad + \quad - \\ 0 - 7\alpha + 21\lambda = 0 \Rightarrow \alpha = 3\lambda \end{array}$$

So, $9\lambda^2 - 3\lambda + 2\lambda = 0$

$$\Rightarrow \lambda = \frac{1}{9} \Rightarrow \alpha = \frac{1}{3} \quad [\because \lambda \neq 0]$$

As $\alpha\beta = 2\lambda \Rightarrow \beta = \frac{2\lambda}{\alpha} = \frac{2 \times \frac{1}{9}}{\frac{1}{3}} = \frac{2}{3}$

and $\alpha\gamma = 9\lambda \Rightarrow \gamma = \frac{9\lambda}{\alpha} = \frac{9 \times \frac{1}{9}}{\frac{1}{3}} = 3$

$$\therefore \frac{\beta\gamma}{\lambda} = \frac{\frac{2}{3} \times 3}{\frac{1}{9}} = 18$$

3. Given quadratic equations

$f(x) = (\lambda^2 + 1)x^2 - 4\lambda x + 2 = 0$ have exactly one root in the interval $(0, 1)$.

So, $D > 0 \Rightarrow 16\lambda^2 - 4(\lambda^2 + 1)2 > 0$

$$\Rightarrow 8\lambda^2 - 8 > 0 \Rightarrow \lambda^2 > 1$$

$$\Rightarrow \lambda \in (-\infty, -1) \cup (1, \infty) \quad \dots(i)$$

and $f(0)f(1) < 0$

$$\Rightarrow 2(\lambda^2 + 1 - 4\lambda + 2) < 0 \Rightarrow \lambda^2 - 4\lambda + 3 < 0$$

$$\Rightarrow (\lambda - 3)(\lambda - 1) < 0 \Rightarrow \lambda \in (1, 3) \quad \dots(ii)$$

From Eqs, (i) and (ii), we get

$$\lambda \in (1, 3)$$

And if $\lambda = 3$, then the quadratic equation is

$$10x^2 - 12x + 2 = 0$$

$$\Rightarrow 5x^2 - 6x + 1 = 0$$

$$\Rightarrow x = 1, \frac{1}{5}$$

\therefore The root $x = \frac{1}{5} \in (0, 1)$ for $\lambda = 3$

$\therefore \lambda \in (1, 3]$.

Hence, option (d) is correct.

4. Given quadratic equation is

$$x^2 + x \sin \theta - 2 \sin \theta = 0, \theta \in \left(0, \frac{\pi}{2}\right)$$

and its roots are α and β .

So, sum of roots $= \alpha + \beta = -\sin \theta$

and product of roots $= \alpha\beta = -2 \sin \theta$

$$\Rightarrow \alpha\beta = 2(\alpha + \beta) \quad \dots(i)$$

Now, the given expression is $\frac{\alpha^{12} + \beta^{12}}{(\alpha^{-12} + \beta^{-12})(\alpha - \beta)^{24}}$

$$= \frac{\alpha^{12} + \beta^{12}}{\left(\frac{1}{\alpha^{12}} + \frac{1}{\beta^{12}}\right)(\alpha - \beta)^{24}} = \frac{\alpha^{12} + \beta^{12}}{\left(\frac{\beta^{12} + \alpha^{12}}{\alpha^{12}\beta^{12}}\right)(\alpha - \beta)^{24}}$$

$$= \left[\frac{\alpha\beta}{(\alpha - \beta)^2}\right]^{12} = \left[\frac{\alpha\beta}{(\alpha + \beta)^2 - 4\alpha\beta}\right]^{12}$$

$$= \left[\frac{2(\alpha + \beta)}{(\alpha + \beta)^2 - 8(\alpha + \beta)}\right]^{12} \quad [\text{from Eq. (i)}]$$

$$= \left(\frac{2}{(\alpha + \beta) - 8}\right)^{12} = \left(\frac{2}{-\sin \theta - 8}\right)^{12} \quad [\because \alpha + \beta = -\sin \theta]$$

$$= \frac{2^{12}}{(\sin \theta + 8)^{12}}$$

5. Given quadratic equation is $x^2 + px + q = 0$, where $p, q \in \mathbf{R}$ having one root $2 - \sqrt{3}$, then other root is $2 + \sqrt{3}$ (conjugate of $2 - \sqrt{3}$) [\because irrational roots of a quadratic equation always occurs in pairs]

So, sum of roots $= -p = 4 \Rightarrow p = -4$

and product of roots $= q = 4 - 3 \Rightarrow q = 1$

Now, from options $p^2 - 4q - 12 = 16 - 4 - 12 = 0$

6. Given quadratic equation is

$$(m^2 + 1)x^2 - 3x + (m^2 + 1) = 0 \quad \dots(i)$$

Let the roots of quadratic Eq. (i) are α and β , so

$$\alpha + \beta = \frac{3}{m^2 + 1} \text{ and } \alpha\beta = m^2 + 1$$

According to the question, the sum of roots is greatest and it is possible only when " $(m^2 + 1)$ is minimum" and "minimum value of $m^2 + 1 = 1$, when $m = 0$ ".

$\therefore \alpha + \beta = 3$ and $\alpha\beta = 1$, as $m = 0$

Now, the absolute difference of the cubes of roots

$$\begin{aligned} &= |\alpha^3 - \beta^3| \\ &= |\alpha - \beta| |\alpha^2 + \beta^2 + \alpha\beta| \\ &= \sqrt{(\alpha + \beta)^2 - 4\alpha\beta} |(\alpha + \beta)^2 - \alpha\beta| \\ &= \sqrt{9 - 4} |9 - 1| = 8\sqrt{5} \end{aligned}$$

36 Theory of Equations

7. Given, α and β are the roots of the quadratic equation,

$$\begin{aligned} x^2 - 2x + 2 &= 0 \\ \Rightarrow (x-1)^2 + 1 &= 0 \\ \Rightarrow (x-1)^2 &= -1 \\ \Rightarrow x-1 &= \pm i \quad [\text{where } i = \sqrt{-1}] \\ \Rightarrow x &= (1+i) \text{ or } (1-i) \end{aligned}$$

Clearly, if $\alpha = 1 + i$, then $\beta = 1 - i$

According to the question $\left(\frac{\alpha}{\beta}\right)^n = 1 \Rightarrow \left(\frac{1+i}{1-i}\right)^n = 1$

$$\Rightarrow \left(\frac{(1+i)(1+i)}{(1-i)(1+i)}\right)^n = 1 \quad [\text{by rationalization}]$$

$$\Rightarrow \left(\frac{1+i^2+2i}{1-i^2}\right)^n = 1 \Rightarrow \left(\frac{2i}{2}\right)^n = 1 \Rightarrow i^n = 1$$

So, minimum value of n is 4. [$\because i^4 = 1$]

8. Key Idea

- (i) First convert the given equation in quadratic equation.
 (ii) Use, Discriminant, $D = b^2 - 4ac < 0$

Given quadratic equation is

$$(1+m^2)x^2 - 2(1+3m)x + (1+8m) = 0 \quad \dots(i)$$

Now, discriminant

$$\begin{aligned} D &= [-2(1+3m)]^2 - 4(1+m^2)(1+8m) \\ &= 4[(1+3m)^2 - (1+m^2)(1+8m)] \\ &= 4[1+9m^2+6m - (1+8m+m^2+8m^3)] \\ &= 4[-8m^3+8m^2-2m] \\ &= -8m(4m^2-4m+1) = -8m(2m-1)^2 \end{aligned}$$

According to the question there is no solution of the quadratic Eq. (i), then

$$D < 0$$

$$\therefore -8m(2m-1)^2 < 0 \Rightarrow m > 0$$

So, there are infinitely many values of 'm' for which, there is no solution of the given quadratic equation.

9. The quadratic expression

$ax^2 + bx + c$, $x \in R$ is always positive,

if $a > 0$ and $D < 0$.

So, the quadratic expression

$$(1+2m)x^2 - 2(1+3m)x + 4(1+m), x \in R \text{ will be}$$

always positive, if $1+2m > 0$... (i)

$$\text{and } D = 4(1+3m)^2 - 4(2m+1)4(1+m) < 0 \quad \dots(ii)$$

From inequality Eq. (i), we get

$$m > -\frac{1}{2} \quad \dots(iii)$$

From inequality Eq. (ii), we get

$$\begin{aligned} 1+9m^2+6m-4(2m^2+3m+1) &< 0 \\ \Rightarrow m^2-6m-3 &< 0 \\ \Rightarrow [m-(3+\sqrt{12})][m-(3-\sqrt{12})] &< 0 \\ [\because m^2-6m-3=0 \Rightarrow m &= \frac{6 \pm \sqrt{36+12}}{2} = 3 \pm \sqrt{12}] \\ \Rightarrow 3-\sqrt{12} < m < 3+\sqrt{12} & \quad \dots(iv) \end{aligned}$$

From inequalities Eqs. (iii) and (iv), the integral values of m are 0, 1, 2, 3, 4, 5, 6

Hence, the number of integral values of m is 7.

10. Let the given quadratic equation in x , $3m^2x^2 + m(m-4)x + 2 = 0$, $m \neq 0$ have roots α and β , then

$$\alpha + \beta = -\frac{m(m-4)}{3m^2} \text{ and } \alpha\beta = \frac{2}{3m^2}$$

Also, let $\frac{\alpha}{\beta} = \lambda$

Then, $\lambda + \frac{1}{\lambda} = 1 \Rightarrow \frac{\alpha}{\beta} + \frac{\beta}{\alpha} = 1$ (given)

$$\Rightarrow \alpha^2 + \beta^2 = \alpha\beta$$

$$\Rightarrow (\alpha + \beta)^2 = 3\alpha\beta$$

$$\Rightarrow \frac{m^2(m-4)^2}{9m^4} = 3 \cdot \frac{2}{3m^2}$$

$$\Rightarrow (m-4)^2 = 18 \quad [\because m \neq 0]$$

$$\Rightarrow m-4 = \pm 3\sqrt{2}$$

$$\Rightarrow m = 4 \pm 3\sqrt{2}$$

The least value of $m = 4 - 3\sqrt{2}$

11. Given quadratic equation is

$$81x^2 + kx + 256 = 0$$

Let one root be α , then other is α^3 .

Now, $\alpha + \alpha^3 = -\frac{k}{81}$ and $\alpha \cdot \alpha^3 = \frac{256}{81}$

[\because for $ax^2 + bx + c = 0$, sum of roots = $-\frac{b}{a}$
 and product of roots = $\frac{c}{a}$]

$$\Rightarrow \alpha^4 = \left(\frac{4}{3}\right)^4$$

$$\Rightarrow \alpha = \pm \frac{4}{3}$$

$$\therefore k = -81(\alpha + \alpha^3)$$

$$= -81(1 + \alpha^2)$$

$$= -81\left(\pm \frac{4}{3}\right)\left(1 + \frac{16}{9}\right) = \pm 300$$

12. Let $a = 5$, $b = 5r$ and $c = 5r^2$

We know that, in a triangle sum of 2 sides is always greater than the third side.

$$\therefore a + b > c; b + c > a \text{ and } c + a > b$$

Now, $a + b > c$

$$\Rightarrow 5 + 5r > 5r^2 \Rightarrow 5r^2 - 5r - 5 < 0$$

$$\Rightarrow r^2 - r - 1 < 0$$

$$\Rightarrow \left[r - \left(\frac{1-\sqrt{5}}{2}\right)\right] \left[r - \left(\frac{1+\sqrt{5}}{2}\right)\right] < 0$$

[\because roots of $ax^2 + bx + c = 0$ are given by

$$x = \frac{-b \pm \sqrt{b^2 - 4ac}}{2a} \text{ and } r^2 - r - 1 = 0$$

$$\Rightarrow r = \frac{1 \pm \sqrt{1+4}}{2} = \frac{1 \pm \sqrt{5}}{2}]$$

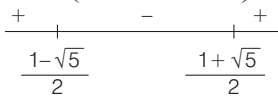
$$\Rightarrow r \in \left(\frac{1-\sqrt{5}}{2}, \frac{1+\sqrt{5}}{2} \right) \quad \dots(i)$$

Similarly, $b + c > a$

$$\Rightarrow 5r + 5r^2 > 5$$

$$\Rightarrow r^2 + r - 1 > 0$$

$$\left[r - \left(\frac{-1-\sqrt{5}}{2} \right) \right] \left[r - \left(\frac{-1+\sqrt{5}}{2} \right) \right] > 0$$

$$\left[\because r^2 + r - 1 = 0 \Rightarrow r = \frac{-1 \pm \sqrt{1+4}}{2} = \frac{-1 \pm \sqrt{5}}{2} \right]$$

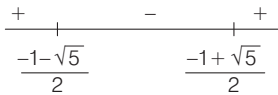
$$\Rightarrow r \in \left(-\infty, \frac{-1-\sqrt{5}}{2} \right) \cup \left(\frac{-1+\sqrt{5}}{2}, \infty \right) \quad \dots(ii)$$

and $c + a > b$

$$\Rightarrow 5r^2 + 5 > 5r$$

$$\Rightarrow r^2 - r + 1 > 0$$

$$\Rightarrow r^2 - 2 \cdot \frac{1}{2}r + \left(\frac{1}{2}\right)^2 + 1 - \left(\frac{1}{2}\right)^2 > 0$$

$$\Rightarrow \left(r - \frac{1}{2}\right)^2 + \frac{3}{4} > 0$$

$$\Rightarrow r \in R \quad \dots(iii)$$

From Eqs. (i), (ii) and (iii), we get

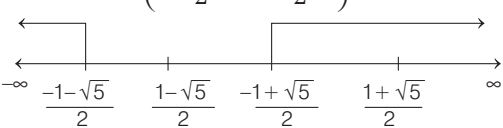
$$r \in \left(\frac{-1+\sqrt{5}}{2}, \frac{1+\sqrt{5}}{2} \right)$$

and $\frac{7}{4}$ is the only value that does not satisfy.

13. Given quadratic equation is

$$x^2 + (3-\lambda)x + 2 = \lambda$$

$$x^2 + (3-\lambda)x + (2-\lambda) = 0 \quad \dots(i)$$

Let Eq. (i) has roots α and β , then $\alpha + \beta = \lambda - 3$ and $\alpha\beta = 2 - \lambda$

\therefore For $ax^2 + bx + c = 0$, sum of roots $= -\frac{b}{a}$
and product of roots $= \frac{c}{a}$

Now, $\alpha^2 + \beta^2 = (\alpha + \beta)^2 - 2\alpha\beta$

$$= (\lambda - 3)^2 - 2(2 - \lambda)$$

$$= \lambda^2 - 6\lambda + 9 - 4 + 2\lambda$$

$$= \lambda^2 - 4\lambda + 5 = (\lambda^2 - 4\lambda + 4) + 1$$

$$= (\lambda - 2)^2 + 1$$

Clearly, $\alpha^2 + \beta^2$ will be least when $\lambda = 2$.

14. For the roots of quadratic equation $ax^2 + bx + c = 0$ to be rational $D = (b^2 - 4ac)$ should be perfect square.

In the equation $6x^2 - 11x + \alpha = 0$
 $a = 6, b = -11$ and $c = \alpha$

\therefore For roots to be rational

$D = (-11)^2 - 4(6)(\alpha)$ should be a perfect square.

$\Rightarrow D(\alpha) = 121 - 24\alpha$ should be a perfect square

Now,

$D(1) = 121 - 24 = 97$ is not a perfect square.

$D(2) = 121 - 24 \times 2 = 73$ is not a perfect square.

$D(3) = 121 - 24 \times 3 = 49$ is a perfect square.

$D(4) = 121 - 24 \times 4 = 25$ is a perfect square.

$D(5) = 121 - 24 \times 5 = 1$ is a perfect square.

and for $\alpha \geq 6, D(\alpha) < 0$, hence imaginary roots.

\therefore For 3 values of α ($\alpha = 3, 4, 5$), the roots are rational.

15. We have, $x^2 + 2x + 2 = 0$

$\Rightarrow x = \frac{-2 \pm \sqrt{4-8}}{2}$ [\because roots of $ax^2 + bx + c = 0$ are

given by $x = \frac{-b \pm \sqrt{b^2 - 4ac}}{2a}$]

$\Rightarrow x = -1 \pm i$

Let $\alpha = -1 + i$ and $\beta = -1 - i$.

Then, $\alpha^{15} + \beta^{15} = (-1 + i)^{15} + (-1 - i)^{15}$

$= -[(1 - i)^{15} + (1 + i)^{15}]$

$= -\left[\left\{ \sqrt{2} \left(\frac{1}{\sqrt{2}} - \frac{i}{\sqrt{2}} \right) \right\}^{15} + \left\{ \sqrt{2} \left(\frac{1}{\sqrt{2}} + \frac{i}{\sqrt{2}} \right) \right\}^{15} \right]$

$= -\left[\left\{ \sqrt{2} \left(\cos \frac{\pi}{4} - i \sin \frac{\pi}{4} \right) \right\}^{15} + \left\{ \sqrt{2} \left(\cos \frac{\pi}{4} + i \sin \frac{\pi}{4} \right) \right\}^{15} \right]$

$= -(\sqrt{2})^{15} \left[\left(\cos \frac{15\pi}{4} - i \sin \frac{15\pi}{4} \right) + \left(\cos \frac{15\pi}{4} + i \sin \frac{15\pi}{4} \right) \right]$

[using De' Moivre's theorem
 $(\cos \theta \pm i \sin \theta)^n = \cos n\theta \pm i \sin n\theta, n \in \mathbb{Z}$]

$= -(\sqrt{2})^{15} \left[2 \cos \frac{15\pi}{4} \right] = -(\sqrt{2})^{15} \left[2 \times \frac{1}{\sqrt{2}} \right]$

$\left[\because \cos \frac{15\pi}{4} = \cos \left(4\pi - \frac{\pi}{4} \right) = \cos \frac{\pi}{4} = \frac{1}{\sqrt{2}} \right]$

$= -(\sqrt{2})^{16} = -2^8$

$= -256.$

Alternate Method

$\alpha^{15} + \beta^{15} = (-1 + i)^{15} + (-1 - i)^{15}$

$= -[(1 - i)^{15} + (1 + i)^{15}]$

$= -\left[\frac{(1 - i)^{16}}{1 - i} + \frac{(1 + i)^{16}}{1 + i} \right]$

$= -\left[\frac{[(1 - i)^2]^8}{1 - i} + \frac{[(1 + i)^2]^8}{1 + i} \right]$

38 Theory of Equations

$$\begin{aligned}
 &= - \left[\frac{[1 + i^2 - 2i]^8}{1 - i} + \frac{[1 + i^2 + 2i]^8}{1 + i} \right] \\
 &= - \left[\frac{(-2i)^8}{1 - i} + \frac{(2i)^8}{1 + i} \right] \\
 &= -2^8 \left[\frac{1}{1 - i} + \frac{1}{1 + i} \right] \quad [\because i^{4n} = 1, n \in \mathbb{Z}] \\
 &= -256 \left[\frac{2}{1 - (i)^2} \right] = -256 \left[\frac{2}{2} \right] = -256
 \end{aligned}$$

16. We have, $2|\sqrt{x} - 3| + \sqrt{x}(\sqrt{x} - 6) + 6 = 0$

$$\begin{aligned}
 &\text{Let } \sqrt{x} - 3 = y \\
 &\Rightarrow \sqrt{x} = y + 3 \\
 \therefore &2|y| + (y + 3)(y - 3) + 6 = 0 \\
 &\Rightarrow 2|y| + y^2 - 3 = 0 \\
 &\Rightarrow |y|^2 + 2|y| - 3 = 0 \\
 &\Rightarrow (|y| + 3)(|y| - 1) = 0 \\
 &\Rightarrow |y| \neq -3 \Rightarrow |y| = 1 \\
 &\Rightarrow y = \pm 1 \Rightarrow \sqrt{x} - 3 = \pm 1 \\
 &\Rightarrow \sqrt{x} = 4, 2 \Rightarrow x = 16, 4
 \end{aligned}$$

17. We have, α, β are the roots of $x^2 - x + 1 = 0$

$$\begin{aligned}
 \therefore &\text{Roots of } x^2 - x + 1 = 0 \text{ are } -\omega, -\omega^2 \\
 \therefore &\text{Let } \alpha = -\omega \text{ and } \beta = -\omega^2 \\
 \Rightarrow &\alpha^{101} + \beta^{107} = (-\omega)^{101} + (-\omega^2)^{107} = -(\omega^{101} + \omega^{214}) \\
 &= -(\omega^2 + \omega) \quad [\because \omega^3 = 1] \\
 &= -(-1) \quad [\because 1 + \omega + \omega^2 = 0] \\
 &= 1
 \end{aligned}$$

18. Given quadratic equation is

$$\begin{aligned}
 &x(x + 1) + (x + 1)(x + 2) + \dots + (x + n - 1)(x + n) = 10n \\
 \Rightarrow &(x^2 + x^2 + \dots + x^2) + [(1 + 3 + 5 + \dots + (2n - 1))x \\
 &\quad + [(1 \cdot 2 + 2 \cdot 3 + \dots + (n - 1)n)] = 10n \\
 \Rightarrow &nx^2 + n^2x + \frac{n(n^2 - 1)}{3} - 10n = 0 \\
 \Rightarrow &x^2 + nx + \frac{n^2 - 1}{3} - 10 = 0 \\
 \Rightarrow &3x^2 + 3nx + n^2 - 31 = 0
 \end{aligned}$$

Let α and β be the roots.

Since, α and β are consecutive.

$$\begin{aligned}
 \therefore &|\alpha - \beta| = 1 \Rightarrow (\alpha - \beta)^2 = 1 \\
 \text{Again, } &(\alpha - \beta)^2 = (\alpha + \beta)^2 - 4\alpha\beta \\
 \Rightarrow &1 = \left(\frac{-3n}{3}\right)^2 - 4\left(\frac{n^2 - 31}{3}\right) \\
 \Rightarrow &1 = n^2 - \frac{4}{3}(n^2 - 31) \Rightarrow 3 = 3n^2 - 4n^2 + 124 \\
 \Rightarrow &n^2 = 121 \Rightarrow n = \pm 11 \\
 \therefore &n = 11 \quad [\because n > 0]
 \end{aligned}$$

19. Given, $(x^2 - 5x + 5)^{x^2 + 4x - 60} = 1$

Clearly, this is possible when

$$\text{I. } x^2 + 4x - 60 = 0 \text{ and } x^2 - 5x + 5 \neq 0$$

or

$$\text{II. } x^2 - 5x + 5 = 1$$

III. $x^2 - 5x + 5 = -1$ and $x^2 + 4x - 60 = \text{Even integer}$.

$$\begin{aligned}
 \text{Case I} &\quad \text{When } x^2 + 4x - 60 = 0 \\
 \Rightarrow &x^2 + 10x - 6x - 60 = 0 \\
 \Rightarrow &x(x + 10) - 6(x + 10) = 0 \\
 \Rightarrow &(x + 10)(x - 6) = 0 \\
 \Rightarrow &x = -10 \text{ or } x = 6
 \end{aligned}$$

Note that, for these two values of x , $x^2 - 5x + 5 \neq 0$

$$\begin{aligned}
 \text{Case II} &\quad \text{When } x^2 - 5x + 5 = 1 \\
 \Rightarrow &x^2 - 5x + 4 = 0 \\
 \Rightarrow &x^2 - 4x - x + 4 = 0 \\
 \Rightarrow &x(x - 4) - 1(x - 4) = 0 \\
 \Rightarrow &(x - 4)(x - 1) = 0 \\
 \Rightarrow &x = 4 \text{ or } x = 1
 \end{aligned}$$

$$\begin{aligned}
 \text{Case III} &\quad \text{When } x^2 - 5x + 5 = -1 \\
 \Rightarrow &x^2 - 5x + 6 = 0 \\
 \Rightarrow &x^2 - 2x - 3x + 6 = 0 \\
 \Rightarrow &x(x - 2) - 3(x - 2) = 0 \\
 \Rightarrow &(x - 2)(x - 3) = 0 \\
 \Rightarrow &x = 2 \text{ or } x = 3
 \end{aligned}$$

Now, when $x = 2$, $x^2 + 4x - 60 = 4 + 8 - 60 = -48$, which is an even integer.

When $x = 3$, $x^2 + 4x - 60 = 9 + 12 - 60 = -39$, which is not an even integer.

Thus, in this case, we get $x = 2$.

Hence, the sum of all real values of

$$x = -10 + 6 + 4 + 1 + 2 = 3$$

20. Here, $x^2 - 2x \sec \theta + 1 = 0$ has roots α_1 and β_1 .

$$\begin{aligned}
 \therefore \alpha_1, \beta_1 &= \frac{2 \sec \theta \pm \sqrt{4 \sec^2 \theta - 4}}{2 \times 1} \\
 &= \frac{2 \sec \theta \pm 2 |\tan \theta|}{2}
 \end{aligned}$$

$$\text{Since, } \theta \in \left(-\frac{\pi}{6}, -\frac{\pi}{12}\right),$$

$$\text{i.e. } \theta \in \text{IV quadrant} = \frac{2 \sec \theta \mp 2 \tan \theta}{2}$$

$$\therefore \alpha_1 = \sec \theta - \tan \theta \text{ and } \beta_1 = \sec \theta + \tan \theta \quad [\text{as } \alpha_1 > \beta_1]$$

and $x^2 + 2x \tan \theta - 1 = 0$ has roots α_2 and β_2 .

$$\text{i.e. } \alpha_2, \beta_2 = \frac{-2 \tan \theta \pm \sqrt{4 \tan^2 \theta + 4}}{2}$$

$$\therefore \alpha_2 = -\tan \theta + \sec \theta$$

$$\text{and } \beta_2 = -\tan \theta - \sec \theta \quad [\text{as } \alpha_2 > \beta_2]$$

$$\text{Thus, } \alpha_1 + \beta_2 = -2 \tan \theta$$

21. Given, α and β are the roots of the equation $x^2 - 6x - 2 = 0$.

$$\therefore a_n = \alpha^n - \beta^n \text{ for } n \geq 1$$

$$a_{10} = \alpha^{10} - \beta^{10}$$

$$a_8 = \alpha^8 - \beta^8$$

$$a_9 = \alpha^9 - \beta^9$$

Now, consider

$$\begin{aligned} \frac{a_{10}-2a_8}{2a_9} &= \frac{\alpha^{10}-\beta^{10}-2(\alpha^8-\beta^8)}{2(\alpha^9-\beta^9)} \\ &= \frac{\alpha^8(\alpha^2-2)-\beta^8(\beta^2-2)}{2(\alpha^9-\beta^9)} \\ &= \frac{\alpha^8 \cdot 6\alpha - \beta^8 \cdot 6\beta}{2(\alpha^9-\beta^9)} = \frac{6\alpha^9-6\beta^9}{2(\alpha^9-\beta^9)} = \frac{6}{2} = 3 \end{aligned}$$

$$\left[\begin{array}{l} \because \alpha \text{ and } \beta \text{ are the roots of} \\ x^2 - 6x - 2 = 0 \text{ or } x^2 = 6x + 2 \\ \Rightarrow \alpha^2 = 6\alpha + 2 \Rightarrow \alpha^2 - 2 = 6\alpha \\ \text{and } \beta^2 = 6\beta + 2 \Rightarrow \beta^2 - 2 = 6\beta \end{array} \right]$$

Alternate Solution

Since, α and β are the roots of the equation

$$x^2 - 6x - 2 = 0.$$

or $x^2 = 6x + 2$

$\therefore \alpha^2 = 6\alpha + 2$
 $\Rightarrow \alpha^{10} = 6\alpha^9 + 2\alpha^8 \dots(i)$

Similarly, $\beta^{10} = 6\beta^9 + 2\beta^8 \dots(ii)$

On subtracting Eq. (ii) from Eq. (i), we get

$$\begin{aligned} \alpha^{10} - \beta^{10} &= 6(\alpha^9 - \beta^9) + 2(\alpha^8 - \beta^8) \quad (\because a_n = \alpha^n - \beta^n) \\ \Rightarrow a_{10} - 2a_8 &= 6a_9 + 2a_8 \\ \Rightarrow a_{10} - 2a_8 &= 6a_9 \\ \Rightarrow \frac{a_{10} - 2a_8}{2a_9} &= 3 \end{aligned}$$

- 22.** If quadratic equation has purely imaginary roots, then coefficient of x must be equal to zero.

Let $p(x) = ax^2 + b$ with a, b of same sign and $a, b \in R$.

Then, $p[p(x)] = a(ax^2 + b)^2 + b$

$p(x)$ has imaginary roots say ix .

Then, also $ax^2 + b \in R$ and $(ax^2 + b)^2 > 0$

$\therefore a(ax^2 + b)^2 + b \neq 0, \forall x$

Thus, $p[p(x)] \neq 0, \forall x$

- 23. PLAN** If $ax^2 + bx + c = 0$ has roots α and β , then $\alpha + \beta = -b/a$ and $\alpha\beta = c/a$. Find the values of $\alpha + \beta$ and $\alpha\beta$ and then put in $(\alpha - \beta)^2 = (\alpha + \beta)^2 - 4\alpha\beta$ to get required value.

Given, α and β are roots of $px^2 + qx + r = 0, p \neq 0$.

$\therefore \alpha + \beta = \frac{-q}{p}, \alpha\beta = \frac{r}{p} \dots(i)$

Since, p, q and r are in AP.

$\therefore 2q = p + r \dots(ii)$

Also, $\frac{1}{\alpha} + \frac{1}{\beta} = 4 \Rightarrow \frac{\alpha + \beta}{\alpha\beta} = 4$

$\Rightarrow \alpha + \beta = 4\alpha\beta \Rightarrow \frac{-q}{p} = \frac{4r}{p}$ [from Eq. (i)]

$\Rightarrow q = -4r$

On putting the value of q in Eq. (ii), we get

$\Rightarrow 2(-4r) = p + r \Rightarrow p = -9r$

Now, $\alpha + \beta = \frac{-q}{p} = \frac{4r}{p} = \frac{4r}{-9r} = -\frac{4}{9}$

and $\alpha\beta = \frac{r}{p} = \frac{r}{-9r} = -\frac{1}{9}$

$\therefore (\alpha - \beta)^2 = (\alpha + \beta)^2 - 4\alpha\beta = \frac{16}{81} + \frac{4}{9} = \frac{16 + 36}{81}$

$\Rightarrow (\alpha - \beta)^2 = \frac{52}{81}$

$\Rightarrow |\alpha - \beta| = \frac{2}{9}\sqrt{13}$

24. $\frac{a_{10} - 2a_8}{2a_9} = \frac{(\alpha^{10} - \beta^{10}) - 2(\alpha^8 - \beta^8)}{2(\alpha^9 - \beta^9)}$
 $= \frac{\alpha^8(\alpha^2 - 2) - \beta^8(\beta^2 - 2)}{2(\alpha^9 - \beta^9)}$

$\therefore \alpha$ is root of $x^2 - 6x - 2 = 0 \Rightarrow \alpha^2 - 2 = 6\alpha$

[and β is root of $x^2 - 6x - 2 = 0 \Rightarrow \beta^2 - 2 = 6\beta$]

$= \frac{\alpha^8(6\alpha) - \beta^8(6\beta)}{2(\alpha^9 - \beta^9)} = \frac{6(\alpha^9 - \beta^9)}{2(\alpha^9 - \beta^9)} = 3$

- 25.** Sum of roots $= \frac{\alpha^2 + \beta^2}{\alpha\beta}$ and product $= 1$

Given, $\alpha + \beta = -p$ and $\alpha^3 + \beta^3 = q$

$\Rightarrow (\alpha + \beta)(\alpha^2 - \alpha\beta + \beta^2) = q$

$\therefore \alpha^2 + \beta^2 - \alpha\beta = \frac{-q}{p} \dots(i)$

and $(\alpha + \beta)^2 = p^2$

$\Rightarrow \alpha^2 + \beta^2 + 2\alpha\beta = p^2 \dots(ii)$

From Eqs. (i) and (ii), we get

$\alpha^2 + \beta^2 = \frac{p^3 - 2q}{3p}$ and $\alpha\beta = \frac{p^3 + q}{3p}$

\therefore Required equation is, $x^2 - \frac{(p^3 - 2q)x}{(p^3 + q)} + 1 = 0$

$\Rightarrow (p^3 + q)x^2 - (p^3 - 2q)x + (p^3 + q) = 0$

- 26.** The equation $x^2 - px + r = 0$ has roots α, β and the equation $x^2 - qx + r = 0$ has roots $\frac{\alpha}{2}, 2\beta$.

$\Rightarrow r = \alpha\beta$ and $\alpha + \beta = p,$

and $\frac{\alpha}{2} + 2\beta = q \Rightarrow \beta = \frac{2q - p}{3}$ and $\alpha = \frac{2(2p - q)}{3}$

$\Rightarrow \alpha\beta = r = \frac{2}{9}(2q - p)(2p - q)$

- 27.** Since, roots are real, therefore $D \geq 0$

$\Rightarrow 4(a + b + c)^2 - 12\lambda(ab + bc + ca) \geq 0$

$\Rightarrow (a + b + c)^2 \geq 3\lambda(ab + bc + ca)$

$\Rightarrow a^2 + b^2 + c^2 \geq (ab + bc + ca)(3\lambda - 2)$

$\Rightarrow 3\lambda - 2 \leq \frac{a^2 + b^2 + c^2}{ab + bc + ca} \dots(i)$

Also, $\cos A = \frac{b^2 + c^2 - a^2}{2bc} < 1$

40 Theory of Equations

$$\begin{aligned} \Rightarrow & b^2 + c^2 - a^2 < 2bc \\ \text{Similarly,} & c^2 + a^2 - b^2 < 2ca \\ \text{and} & a^2 + b^2 - c^2 < 2ab \\ \Rightarrow & a^2 + b^2 + c^2 < 2(ab + bc + ca) \\ \Rightarrow & \frac{a^2 + b^2 + c^2}{ab + bc + ca} < 2 \quad \dots(\text{ii}) \end{aligned}$$

From Eqs. (i) and (ii), we get

$$3\lambda - 2 < 2 \Rightarrow \lambda < \frac{4}{3}$$

28. Let the roots of $x^2 + px + q = 0$ be α and α^2 .

$$\begin{aligned} \Rightarrow & \alpha + \alpha^2 = -p \quad \text{and} \quad \alpha^3 = q \\ \Rightarrow & \alpha(\alpha + 1) = -p \\ \Rightarrow & \alpha^3\{\alpha^3 + 1 + 3\alpha(\alpha + 1)\} = -p^3 \quad [\text{cubing both sides}] \\ \Rightarrow & q(q + 1 - 3p) = -p^3 \\ \Rightarrow & p^3 - (3p - 1)q + q^2 = 0 \end{aligned}$$

29. Given, $x^2 - |x + 2| + x > 0$... (i)

Case I When $x + 2 \geq 0$

$$\begin{aligned} \therefore & x^2 - x - 2 + x > 0 \Rightarrow x^2 - 2 > 0 \\ \Rightarrow & x < -\sqrt{2} \quad \text{or} \quad x > \sqrt{2} \\ \Rightarrow & x \in [-2, -\sqrt{2}) \cup (\sqrt{2}, \infty) \quad \dots(\text{ii}) \end{aligned}$$

Case II When $x + 2 < 0$

$$\begin{aligned} \therefore & x^2 + x + 2 + x > 0 \\ \Rightarrow & x^2 + 2x + 2 > 0 \\ \Rightarrow & (x + 1)^2 + 1 > 0 \end{aligned}$$

which is true for all x .

$$\therefore x \leq -2 \quad \text{or} \quad x \in (-\infty, -2) \quad \dots(\text{iii})$$

From Eqs. (ii) and (iii), we get

$$x \in (-\infty, -\sqrt{2}) \cup (\sqrt{2}, \infty)$$

30. Given, $\log_4(x - 1) = \log_2(x - 3) = \log_{4^{1/2}}(x - 3)$

$$\begin{aligned} \Rightarrow & \log_4(x - 1) = 2 \log_4(x - 3) \\ \Rightarrow & \log_4(x - 1) = \log_4(x - 3)^2 \\ \Rightarrow & (x - 3)^2 = x - 1 \\ \Rightarrow & x^2 + 9 - 6x = x - 1 \\ \Rightarrow & x^2 - 7x + 10 = 0 \\ \Rightarrow & (x - 2)(x - 5) = 0 \\ \Rightarrow & x = 2, \quad \text{or} \quad x = 5 \\ \Rightarrow & x = 5 \quad [\because x = 2 \text{ makes } \log(x - 3) \text{ undefined}] \end{aligned}$$

Hence, one solution exists.

31. Let α, α^2 be the roots of $3x^2 + px + 3 = 0$

$$\begin{aligned} \text{Now,} & S = \alpha + \alpha^2 = -p/3, \\ & P = \alpha^3 = 1 \\ \Rightarrow & \alpha = 1, \omega, \omega^2 \\ \text{Now,} & \alpha + \alpha^2 = -p/3 \\ \Rightarrow & \omega + \omega^2 = -p/3 \end{aligned}$$

$$\begin{aligned} \Rightarrow & -1 = -p/3 \\ \Rightarrow & p = 3 \end{aligned}$$

32. Given, $c < 0 < b$
 Since, $\alpha + \beta = -b$... (i)
 and $\alpha\beta = c$... (ii)

From Eq. (ii), $c < 0 \Rightarrow \alpha\beta < 0$

\Rightarrow Either α is -ve, β is -ve or α is +ve, β is -ve.

From Eq. (i), $b > 0 \Rightarrow -b < 0 \Rightarrow \alpha + \beta < 0 \Rightarrow$ the sum is negative.

\Rightarrow Modulus of negative quantity is $>$ modulus of positive quantity but $\alpha < \beta$ is given.

Therefore, it is clear that α is negative and β is positive and modulus of α is greater than modulus of β

$$\Rightarrow \alpha < 0 < \beta < |\alpha|$$

NOTE This question is not on the theory of interval in which root lie, which appears looking at first sight. It is new type and first time asked in the paper. It is important for future. The actual type is interval in which parameter lie.

33. Since, $\sqrt{x+1} - \sqrt{x-1} = \sqrt{4x-1}$
 $\Rightarrow (x+1) + (x-1) - 2\sqrt{x^2-1} = 4x-1$
 $\Rightarrow 1-2x = 2\sqrt{x^2-1} \Rightarrow 1+4x^2-4x = 4x^2-4$
 $\Rightarrow 4x = 5 \Rightarrow x = \frac{5}{4}$

But it does not satisfy the given equation.

Hence, no solution exists.

34. Given, $x^{\frac{3}{4}(\log_2 x)^2 + \log_2 x} - \frac{5}{4} = \sqrt{2}$
 $\Rightarrow \frac{3}{4}(\log_2 x)^2 + \log_2 x - \frac{5}{4} = \log_x \sqrt{2}$
 $\Rightarrow \frac{3}{4}(\log_2 x)^2 + \log_2 x - \frac{5}{4} = \frac{1}{2 \log_2 x}$
 $\Rightarrow 3(\log_2 x)^3 + 4(\log_2 x)^2 - 5(\log_2 x) - 2 = 0$
 Put $\log_2 x = y$
 $\therefore 3y^3 + 4y^2 - 5y - 2 = 0$
 $\Rightarrow (y-1)(y+2)(3y+1) = 0$
 $\Rightarrow y = 1, -2, -1/3$
 $\Rightarrow \log_2 x = 1, -2, -1/3$
 $\Rightarrow x = 2, \frac{1}{2^{1/3}}, \frac{1}{4}$

35. Since, α, β are the roots of $x^2 + px + q = 0$ and α^4, β^4 are the roots of $x^2 - rx + s = 0$.

$$\Rightarrow \alpha + \beta = -p; \alpha\beta = q; \alpha^4 + \beta^4 = r \quad \text{and} \quad \alpha^4\beta^4 = s$$

Let roots of $x^2 - 4qx + (2q^2 - r) = 0$ be α' and β'

$$\begin{aligned} \text{Now,} \quad \alpha' \beta' &= (2q^2 - r) = 2(\alpha\beta)^2 - (\alpha^4 + \beta^4) \\ &= -(\alpha^4 + \beta^4 - 2\alpha^2\beta^2) = -(\alpha^2 - \beta^2)^2 < 0 \end{aligned}$$

\Rightarrow Roots are real and of opposite sign.

36. Given, $x - \frac{2}{x-1} = 1 - \frac{2}{x-1} \Rightarrow x = 1$

But at $x = 1$, the given equation is not defined.

Hence, no solution exist.

37. Let $y = \frac{x^2 - (a+b)x + ab}{x-c}$
 $\Rightarrow yx - cy = x^2 - (a+b)x + ab$
 $\Rightarrow x^2 - (a+b+y)x + (ab+cy) = 0$
 For real roots, $D \geq 0$
 $\Rightarrow (a+b+y)^2 - 4(ab+cy) \geq 0$
 $\Rightarrow (a+b)^2 + y^2 + 2(a+b)y - 4ab - 4cy \geq 0$
 $\Rightarrow y^2 + 2(a+b-2c)y + (a-b)^2 \geq 0$
 which is true for all real values of y .
 $\therefore D \leq 0$
 $4(a+b-2c)^2 - 4(a-b)^2 \leq 0$
 $\Rightarrow 4(a+b-2c+a-b)(a+b-2c-a+b) \leq 0$
 $\Rightarrow (2a-2c)(2b-2c) \leq 0$
 $\Rightarrow (a-c)(b-c) \leq 0$
 $\Rightarrow (c-a)(c-b) \leq 0$
 $\Rightarrow c$ must lie between a and b
 i.e. $a \leq c \leq b$ or $b \leq c \leq a$

38. Since, $|x|^2 - 3|x| + 2 = 0$
 $\Rightarrow (|x|-1)(|x|-2) = 0$
 $\Rightarrow |x| = 1, 2$
 $\therefore x = 1, -1, 2, -2$
 Hence, four real solutions exist.

39. $(x-a)(x-b) + (x-b)(x-c) + (x-c)(x-a) = 0$
 $\Rightarrow 3x^2 - 2(a+b+c)x + (ab+bc+ca) = 0$
 Now, discriminant $= 4(a+b+c)^2 - 12(ab+bc+ca)$
 $= 4\{a^2 + b^2 + c^2 - ab - bc - ca\}$
 $= 2\{(a-b)^2 + (b-c)^2 + (c-a)^2\}$
 which is always positive.
 Hence, both roots are real.

40. Since, $a, b, c > 0$ and $ax^2 + bx + c = 0$
 $\Rightarrow x = \frac{-b \pm \sqrt{b^2 - 4ac}}{2a}$
Case I When $b^2 - 4ac > 0$
 $\Rightarrow x = \frac{-b}{2a} \pm \frac{\sqrt{b^2 - 4ac}}{2a}$
 and $\frac{-b}{2a} + \frac{\sqrt{b^2 - 4ac}}{2a}$ both roots, are negative.

Case II When $b^2 - 4ac = 0$
 $\Rightarrow x = \frac{-b}{2a}$, i.e. both roots are equal and negative

Case III When $b^2 - 4ac < 0$
 $\Rightarrow x = \frac{-b}{2a} \pm i \frac{\sqrt{4ac - b^2}}{2a}$

have negative real part.
 \therefore From above discussion, both roots have negative real parts.

41. Given, $x^2 + 2px + q = 0$
 $\therefore \alpha + \beta = -2p$... (i)
 $\alpha\beta = q$... (ii)
 And $ax^2 + 2bx + c = 0$
 $\therefore \alpha + \frac{1}{\beta} = -\frac{2b}{a}$... (iii)
 and $\frac{\alpha}{\beta} = \frac{c}{a}$... (iv)

Now, $(p^2 - q)(b^2 - ac)$

$$= \left[\left(\frac{\alpha + \beta}{-2} \right)^2 - \alpha\beta \right] \left[\left(\frac{\alpha + \frac{1}{\beta}}{2} \right)^2 - \frac{\alpha}{\beta} \right] a^2$$

$$= \frac{(\alpha - \beta)^2}{16} \left(\alpha - \frac{1}{\beta} \right)^2 \cdot a^2 \geq 0$$

\therefore Statement I is true.
 Again, now $pa = -\left(\frac{\alpha + \beta}{2}\right)a = -\frac{a}{2}(\alpha + \beta)$
 and $b = -\frac{a}{2}\left(\alpha + \frac{1}{\beta}\right)$
 Since, $pa \neq b \Rightarrow \alpha + \frac{1}{\beta} \neq \alpha + \beta$
 $\Rightarrow \beta^2 \neq 1, \beta \neq \{-1, 0, 1\}$, which is correct.
 Similarly, if $c \neq qa$
 $\Rightarrow \alpha \frac{\alpha}{\beta} \neq a\alpha\beta \Rightarrow \alpha\left(\beta - \frac{1}{\beta}\right) \neq 0$
 $\Rightarrow \alpha \neq 0$ and $\beta - \frac{1}{\beta} \neq 0$
 $\Rightarrow \beta \neq \{-1, 0, 1\}$

Statement II is true.
 Both Statement I and Statement II are true. But Statement II does not explain Statement I.

42. Given, $|x-2|^2 + |x-2| - 2 = 0$
Case I When $x \geq 2$
 $\Rightarrow (x-2)^2 + (x-2) - 2 = 0$
 $\Rightarrow x^2 + 4 - 4x + x - 2 - 2 = 0$
 $\Rightarrow x^2 - 3x = 0$
 $\Rightarrow x(x-3) = 0$
 $\Rightarrow x = 0, 3$ [0 is rejected]
 $\Rightarrow x = 3$... (i)
Case II When $x < 2$
 $\Rightarrow \{-(x-2)\}^2 - (x-2) - 2 = 0$
 $\Rightarrow (x-2)^2 - x + 2 - 2 = 0$
 $\Rightarrow x^2 + 4 - 4x - x = 0$
 $\Rightarrow x^2 - 4x - (x-4) = 0$
 $\Rightarrow x(x-4) - 1(x-4) = 0$
 $\Rightarrow (x-1)(x-4) = 0$

42 Theory of Equations

$$\begin{aligned} \Rightarrow & x = 1, 4 && [4 \text{ is rejected}] \\ \Rightarrow & x = 1 && \dots(\text{ii}) \end{aligned}$$

Hence, the sum of the roots is $3 + 1 = 4$.

Alternate Solution

$$\begin{aligned} \text{Given, } & |x-2|^2 + |x-2| - 2 = 0 \\ \Rightarrow & (|x-2| + 2)(|x-2| - 1) = 0 \\ \therefore & |x-2| = -2, 1 && [\text{neglecting } -2] \\ \Rightarrow & |x-2| = 1 \Rightarrow x = 3, 1 \\ \Rightarrow & \text{Sum of the roots} = 4 \end{aligned}$$

43. Since, $x^2 - 3kx + 2e^{2 \log k} - 1 = 0$ has product of roots 7.

$$\begin{aligned} \Rightarrow & 2e^{2 \log k} - 1 = 7 \\ \Rightarrow & e^{2 \log k} = 4 \\ \Rightarrow & k^2 = 4 \\ \Rightarrow & k = 2 && [\text{neglecting } -2] \end{aligned}$$

44. If $2 + i\sqrt{3}$ is one of the root of $x^2 + px + q = 0$. Then, other root is $2 - i\sqrt{3}$.

$$\begin{aligned} \Rightarrow & -p = 2 + i\sqrt{3} + 2 - i\sqrt{3} = 4 \\ \text{and } & q = (2 + i\sqrt{3})(2 - i\sqrt{3}) = 7 \\ \Rightarrow & (p, q) = (-4, 7) \end{aligned}$$

45. The coefficient of x^{99} in $(x-1)(x-2)\dots(x-100)$

$$\begin{aligned} &= -(1+2+3+\dots+100) \\ &= -\frac{100}{2}(1+100) = -50(101) = -5050 \end{aligned}$$

46. $P(x) \cdot Q(x) = (ax^2 + bx + c)(-ax^2 + bx + c)$

Now, $D_1 = b^2 - 4ac$ and $D_2 = b^2 + 4ac$

Clearly, $D_1 + D_2 = 2b^2 \geq 0$

\therefore Atleast one of D_1 and D_2 is (+ve). Hence, atleast two real roots.

Hence, statement is true.

47. Given, $2x^2 + 3x + 1 = 0$

Here, $D = (3)^2 - 4 \cdot 2 \cdot 1 = 1$ which is a perfect square.

\therefore Roots are rational.

Hence, statement is false.

48. Here, $a + b = 10c$ and $c + d = 10a$

$$\begin{aligned} \Rightarrow & (a - c) + (b - d) = 10(c - a) \\ \Rightarrow & (b - d) = 11(c - a) && \dots(\text{i}) \end{aligned}$$

Since, 'c' is the root of $x^2 - 10ax - 11b = 0$

$$\Rightarrow c^2 - 10ac - 11b = 0 \quad \dots(\text{ii})$$

Similarly, 'a' is the root of

$$\begin{aligned} & x^2 - 10cx - 11d = 0 \\ \Rightarrow & a^2 - 10ca - 11d = 0 && \dots(\text{iii}) \end{aligned}$$

On subtracting Eq. (iv) from Eq. (ii), we get

$$(c^2 - a^2) = 11(b - d) \quad \dots(\text{iv})$$

$$\begin{aligned} \therefore & (c + a)(c - a) = 11 \times 11(c - a) && [\text{from Eq. (i)}] \\ \Rightarrow & c + a = 121 \end{aligned}$$

$$\begin{aligned} \therefore & a + b + c + d = 10c + 10a \\ & = 10(c + a) = 1210 \end{aligned}$$

49. Since, $\alpha + \beta = -\frac{b}{a}$, $\alpha\beta = \frac{c}{a}$

and $\alpha + \delta + \beta + \delta = -\frac{B}{A}$, $(\alpha + \delta)(\beta + \delta) = \frac{C}{A}$

Now,

$$\begin{aligned} \Rightarrow & \alpha - \beta = (\alpha + \delta) - (\beta + \delta) \\ \Rightarrow & (\alpha - \beta)^2 = [(\alpha + \delta) - (\beta + \delta)]^2 \\ \Rightarrow & (\alpha + \beta)^2 - 4\alpha\beta = (\alpha + \delta + \beta + \delta)^2 - 4(\alpha + \delta)(\beta + \delta) \\ \Rightarrow & \left(-\frac{b}{a}\right)^2 - \frac{4c}{a} = \left(-\frac{B}{A}\right)^2 - \frac{4C}{A} \\ \Rightarrow & \frac{b^2}{a^2} - \frac{4c}{a} = \frac{B^2}{A^2} - \frac{4C}{A} \\ \Rightarrow & \frac{b^2 - 4ac}{a^2} = \frac{B^2 - 4AC}{A^2} \end{aligned}$$

50. Suppose $f(x) = Ax^2 + Bx + C$ is an integer, whenever x is an integer.

$$\begin{aligned} \therefore & f(0), f(1), f(-1) \text{ are integers.} \\ \Rightarrow & C, A + B + C, A - B + C \text{ are integers.} \\ \Rightarrow & C, A + B, A - B \text{ are integers.} \\ \Rightarrow & C, A + B, (A + B) - (A - B) = 2A \text{ are integers.} \end{aligned}$$

Conversely, suppose $2A, A + B$ and C are integers.

Let n be any integer. We have,

$$f(n) = An^2 + Bn + C = 2A \left[\frac{n(n-1)}{2} \right] + (A+B)n + C$$

Since, n is an integer, $n(n-1)/2$ is an integer. Also, $2A, A+B$ and C are integers.

We get $f(n)$ is an integer for all integer n .

51. Given, $2^{|y|} - |2^{y-1} - 1| = 2^{y-1} + 1$

Case I When $y \in (-\infty, 0]$

$$\begin{aligned} \therefore & 2^{-y} + (2^{y-1} - 1) = 2^{y-1} + 1 \\ \Rightarrow & 2^{-y} = 2 \\ \Rightarrow & y = -1 \in (-\infty, 0] && \dots(\text{i}) \end{aligned}$$

Case II When $y \in (0, 1]$

$$\begin{aligned} \therefore & 2^y + (2^{y-1} - 1) = 2^{y-1} + 1 \\ \Rightarrow & 2^y = 2 \\ \Rightarrow & y = 1 \in (0, 1] && \dots(\text{ii}) \end{aligned}$$

Case III When $y \in (1, \infty)$

$$\begin{aligned} \therefore & 2^y - 2^{y-1} + 1 = 2^{y-1} + 1 \\ \Rightarrow & 2^y - 2 \cdot 2^{y-1} = 0 \\ \Rightarrow & 2^y - 2^y = 0 \text{ true for all } y > 1 && \dots(\text{iii}) \end{aligned}$$

From Eqs. (i), (ii) and (iii), we get

$$y \in \{-1\} \cup [1, \infty).$$

52. Given, $\frac{2x}{2x^2 + 5x + 2} > \frac{1}{x+1}$

$$\begin{aligned} \Rightarrow & \frac{2x}{(2x+1)(x+2)} - \frac{1}{x+1} > 0 \\ \Rightarrow & \frac{2x(x+1) - (2x+1)(x+2)}{(2x+1)(x+2)(x+1)} > 0 \end{aligned}$$

$$\Rightarrow \frac{-(3x+2)}{(2x+1)(x+1)(x+2)} > 0; \text{ using number line rule}$$

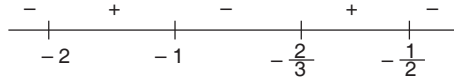

$$\therefore x \in (-2, -1) \cup \left(-\frac{2}{3}, -\frac{1}{2}\right)$$

53. Given, $|x^2 + 4x + 3| + 2x + 5 = 0$

Case I $x^2 + 4x + 3 > 0 \Rightarrow (x < -3 \text{ or } x > -1)$
 $\therefore x^2 + 4x + 3 + 2x + 5 = 0$
 $\Rightarrow x^2 + 6x + 8 = 0 \Rightarrow (x+4)(x+2) = 0$
 $\Rightarrow x = -4, -2$ [but $x < -3$ or $x > -1$]
 $\therefore x = -4$ is the only solution. ... (i)

Case II $x^2 + 4x + 3 < 0 \Rightarrow (-3 < x < -1)$
 $\therefore -x^2 - 4x - 3 + 2x + 5 = 0$
 $\Rightarrow x^2 + 2x - 2 = 0 \Rightarrow (x+1)^2 = 3$
 $\Rightarrow |x+1| = \sqrt{3}$
 $\Rightarrow x = -1 - \sqrt{3}, -1 + \sqrt{3}$ [but $x \in (-3, -1)$]
 $\therefore x = -1 - \sqrt{3}$ is the only solution. ... (ii)

From Eqs. (i) and (ii), we get
 $x = -4$ and $(-1 - \sqrt{3})$ are the only solutions.

54. Here, $a \leq 0$

Given, $x^2 - 2a|x - a| - 3a^2 = 0$
Case I When $x \geq a$
 $\Rightarrow x^2 - 2a(x - a) - 3a^2 = 0$
 $\Rightarrow x^2 - 2ax - a^2 = 0$
 $\Rightarrow x = a \pm \sqrt{2}a$
 [as $a(1 + \sqrt{2}) < a$ and $a(1 - \sqrt{2}) > a$]

\therefore Neglecting $x = a(1 + \sqrt{2})$ as $x \geq a$
 $\Rightarrow x = a(1 - \sqrt{2})$... (i)

Case II When $x < a \Rightarrow x^2 + 2a(x - a) - 3a^2 = 0$
 $\Rightarrow x^2 + 2ax - 5a^2 = 0 \Rightarrow x = -a \pm \sqrt{6}a$
 [as $a(\sqrt{6} - 1) < a$ and $a(-1 - \sqrt{6}) > a$]
 \therefore Neglecting $x = a(-1 - \sqrt{6}) \Rightarrow x = a(\sqrt{6} - 1)$... (ii)

From Eqs. (i) and (ii), we get
 $x = \{a(1 - \sqrt{2}), a(\sqrt{6} - 1)\}$

55. Given, $(5 + 2\sqrt{6})^{x^2-3} + (5 - 2\sqrt{6})^{x^2-3} = 10$... (i)

Put $y = (5 + 2\sqrt{6})^{x^2-3} \Rightarrow (5 - 2\sqrt{6})^{x^2-3} = \frac{1}{y}$

From Eq. (i), $y + \frac{1}{y} = 10$
 $\Rightarrow y^2 - 10y + 1 = 0 \Rightarrow y = 5 \pm 2\sqrt{6}$
 $\Rightarrow (5 + 2\sqrt{6})^{x^2-3} = 5 + 2\sqrt{6}$
 or $(5 + 2\sqrt{6})^{x^2-3} = 5 - 2\sqrt{6}$
 $\Rightarrow x^2 - 3 = 1$ or $x^2 - 3 = -1$
 $\Rightarrow x = \pm 2$ or $x = \pm \sqrt{2}$
 $\Rightarrow x = \pm 2, \pm \sqrt{2}$

56. Let α, β are roots of $ax^2 + bx + c = 0$

Given, $\alpha = \beta^n$
 $\Rightarrow \alpha\beta = \frac{c}{a} \Rightarrow \beta^{n+1} = \frac{c}{a} \Rightarrow \beta = \left(\frac{c}{a}\right)^{1/(n+1)}$

It must satisfy $ax^2 + bx + c = 0$
 i.e. $a\left(\frac{c}{a}\right)^{2/(n+1)} + b\left(\frac{c}{a}\right)^{1/(n+1)} + c = 0$

$$\Rightarrow \frac{a \cdot c^{2/(n+1)}}{a^{2/(n+1)}} + \frac{b \cdot c^{1/(n+1)}}{a^{1/(n+1)}} + c = 0$$

$$\Rightarrow \frac{c^{1/(n+1)}}{a^{1/(n+1)}} \left\{ \frac{a \cdot c^{1/(n+1)}}{a^{1/(n+1)}} + b + \frac{c \cdot a^{1/(n+1)}}{c^{1/(n+1)}} \right\} = 0$$

$$\Rightarrow a^{n/(n+1)} c^{1/(n+1)} + b + c^{n/(n+1)} a^{1/(n+1)} = 0$$

$$\Rightarrow (a^n c)^{1/(n+1)} + (c^n a)^{1/(n+1)} + b = 0$$

57. Since, α, β are the roots of $x^2 + px + q = 0$

and γ, δ are the roots of $x^2 + rx + s = 0$
 $\therefore \alpha + \beta = -p, \alpha\beta = q$ and $\gamma + \delta = -r, \gamma\delta = s$

Now, $(\alpha - \gamma)(\alpha - \delta)(\beta - \gamma)(\beta - \delta)$
 $= [\alpha^2 - (\gamma + \delta)\alpha + \gamma\delta][\beta^2 - (\gamma + \delta)\beta + \gamma\delta]$
 $= (\alpha^2 + r\alpha + s)(\beta^2 + r\beta + s)$
 $= (\alpha\beta)^2 + r(\alpha + \beta)\alpha\beta + s(\alpha^2 + \beta^2) + \alpha\beta r^2 + rs(\alpha + \beta) + s^2$
 $= q^2 - rqp + s(p^2 - 2q) + qr^2 - rsp + s^2$
 $= (q - s)^2 - rqp - rsp + sp^2 + qr^2$

58. The given equation can be rewritten as

$$\frac{2}{\log_a x} + \frac{1}{\log_a ax} + \frac{3}{\log_a a^2 x} = 0 \quad [\because b = a^2 x, \text{ given}]$$

$$\Rightarrow \frac{2}{\log_a x} + \frac{1}{1 + \log_a x} + \frac{3}{2 + \log_a x} = 0$$

$$\Rightarrow \frac{2}{t} + \frac{1}{1+t} + \frac{3}{2+t} = 0, \text{ where } t = \log_a x$$

$$\Rightarrow 2(1+t)(2+t) + 3t(1+t) + t(2+t) = 0$$

$$\Rightarrow 6t^2 + 11t + 4 = 0$$

$$\Rightarrow (2t+1)(3t+4) = 0$$

$$\Rightarrow t = -\frac{1}{2} \text{ or } -\frac{4}{3}$$

$$\therefore \log_a x = -\frac{1}{2} \text{ or } \log_a x = -\frac{4}{3}$$

$$\Rightarrow x = a^{-1/2} \text{ or } x = a^{-4/3}$$

59. Since, $\alpha + \beta = -p, \alpha\beta = 1$ and $\gamma + \delta = -q, \gamma\delta = 1$

Now, $(\alpha - \gamma)(\beta - \gamma)(\alpha + \delta)(\beta + \delta)$
 $= \{\alpha\beta - \gamma(\alpha + \beta) + \gamma^2\} \{\alpha\beta + \delta(\alpha + \beta) + \delta^2\}$
 $= \{1 - \gamma(-p) + \gamma^2\} \{1 + \delta(-p) + \delta^2\}$
 $= (1 + \gamma^2 + \gamma p)(1 - \delta p + \delta^2) = (-q\gamma + \gamma p)(-\delta p - \delta q)$
 $[\because \gamma^2 + q\gamma + 1 = 0 \text{ and } \delta^2 + q\delta + 1 = 0]$
 $= (q^2 - p^2)(\gamma\delta) = q^2 - p^2 \quad [\because \gamma\delta = 1]$

44 Theory of Equations

60. $\alpha^2 = \alpha + 1$
 $\beta^2 = \beta + 1$
 $a_n = p\alpha^n + q\beta^n$
 $= p(\alpha^{n-1} + \alpha^{n-2}) + q(\beta^{n-1} + \beta^{n-2})$
 $= a_{n-1} + a_{n-2}$
 $\therefore a_{12} = a_{11} + a_{10}$

61. $\alpha = \frac{1 + \sqrt{5}}{2}, \beta = \frac{1 - \sqrt{5}}{2}$
 $a_4 = a_3 + a_2$
 $= 2a_2 + a_1$
 $= 3a_1 + 2a_0$
 $28 = p(3\alpha + 2) + q(3\beta + 2)$
 $28 = (p + q)\left(\frac{3}{2} + 2\right) + (p - q)\left(\frac{3\sqrt{5}}{2}\right)$
 $\therefore p - q = 0$
and $(p + q) \times \frac{7}{2} = 28$
 $\Rightarrow p + q = 8$
 $\Rightarrow p = q = 4$
 $\therefore p + 2q = 12$

Topic 2 Common Roots

- 1 Given α, β and γ are three consecutive terms of a non-constant GP.

Let $\alpha = \alpha, \beta = \alpha r, \gamma = \alpha r^2, \{r \neq 0, 1\}$

and given quadratic equation is

$$\alpha x^2 + 2\beta x + \gamma = 0 \quad \dots(i)$$

On putting the values of α, β, γ in Eq. (i), we get

$$\alpha x^2 + 2\alpha r x + \alpha r^2 = 0$$

$$\Rightarrow x^2 + 2rx + r^2 = 0$$

$$\Rightarrow (x + r)^2 = 0$$

$$\Rightarrow x = -r$$

\therefore The quadratic equations $\alpha x^2 + 2\beta x + \gamma = 0$ and $x^2 + x - 1 = 0$ have a common root, so $x = -r$ must be root of equation $x^2 + x - 1 = 0$, so

$$r^2 - r - 1 = 0 \quad \dots(ii)$$

Now, $\alpha(\beta + \gamma) = \alpha(\alpha r + \alpha r^2)$
 $= \alpha^2(r + r^2)$

From the options,

$$\beta\gamma = \alpha r \cdot \alpha r^2 = \alpha^2 r^3 = \alpha^2(r + r^2)$$

$$[\because r^2 - r - 1 = 0 \Rightarrow r^3 = r + r^2]$$

$$\therefore \alpha(\beta + \gamma) = \beta\gamma$$

2. Given equations are $x^2 + 2x + 3 = 0$ $\dots(i)$

and $ax^2 + bx + c = 0$ $\dots(ii)$

Since, Eq. (i) has imaginary roots, so Eq. (ii) will also have both roots same as Eq. (i).

Thus, $\frac{a}{1} = \frac{b}{2} = \frac{c}{3}$

Hence, $a : b : c$ is $1 : 2 : 3$.

3. If $a_1x^2 + b_1x + c_1 = 0$
and $a_2x^2 + b_2x + c_2 = 0$
have a common real root, then
 $\Rightarrow (a_1c_2 - a_2c_1)^2 = (b_1c_2 - b_2c_1)(a_1b_2 - a_2b_1)$
 $\therefore \left. \begin{array}{l} x^2 + bx - 1 = 0 \\ x^2 + x + b = 0 \end{array} \right\}$ have a common root.
 $\Rightarrow (1 + b)^2 = (b^2 + 1)(1 - b)$
 $\Rightarrow b^2 + 2b + 1 = b^2 - b^3 + 1 - b$
 $\Rightarrow b^3 + 3b = 0$
 $\therefore b(b^2 + 3) = 0$
 $\Rightarrow b = 0, \pm\sqrt{3}i$

4. Given equations are $x^2 + ax + b = 0$ and $x^2 + bx + a = 0$ have common root
On subtracting above equations, we get
 $(a - b)x + (b - a) = 0$
 $\Rightarrow x = 1$
 $\therefore x = 1$ is the common root.
 $\Rightarrow 1 + a + b = 0$
 $\Rightarrow a + b = -1$

5. Since, $(x - r)$ is a factor of the polynomial

$$f(x) = a_n x^n + a_{n-1} x^{n-1} + \dots + a_0$$

Then, $x = r$ is root of $f'(x) = 0$ repeated $(m - 1)$ times.

Hence, statement is false.

Topic 3 Transformation of Roots

1. Given, α, β are the roots of $(x - a)(x - b) - c = 0$
 $\Rightarrow (x - a)(x - b) - c = (x - \alpha)(x - \beta)$
 $\Rightarrow (x - a)(x - b) = (x - \alpha)(x - \beta) + c$
 $\Rightarrow a, b$ are the roots of equation $(x - \alpha)(x - \beta) + c = 0$

2. Since, $ax^2 + bx + c = 0$ has roots α and β .

$$\Rightarrow \alpha + \beta = -b/a$$

and $\alpha\beta = c/a$

Now, $a^3x^2 + abcx + c^3 = 0$ $\dots(i)$

On dividing the equation by c^2 , we get

$$\frac{a^3}{c^2}x^2 + \frac{abcx}{c^2} + \frac{c^3}{c^2} = 0$$

$$\Rightarrow a\left(\frac{ax}{c}\right)^2 + b\left(\frac{ax}{c}\right) + c = 0$$

$$\Rightarrow \frac{ax}{c} = \alpha, \beta \text{ are the roots}$$

$$\Rightarrow x = \frac{c}{a}\alpha, \frac{c}{a}\beta \text{ are the roots}$$

$$\Rightarrow x = \alpha\beta\alpha, \alpha\beta\beta \text{ are the roots}$$

$$\Rightarrow x = \alpha^2\beta, \alpha\beta^2 \text{ are the roots}$$

Divide the Eq. (i) by a^3 , we get

$$x^2 + \frac{b}{a} \cdot \frac{c}{a} \cdot x + \left(\frac{c}{a}\right)^3 = 0$$

$$\Rightarrow x^2 - (\alpha + \beta) \cdot (\alpha\beta) x + (\alpha\beta)^3 = 0$$

$$\Rightarrow x^2 - \alpha^2\beta x - \alpha\beta^2 x + (\alpha\beta)^3 = 0$$

$$\Rightarrow x(x - \alpha^2\beta) - \alpha\beta^2(x - \alpha^2\beta) = 0$$

$$\Rightarrow (x - \alpha^2\beta)(x - \alpha\beta^2) = 0$$

$$\Rightarrow x = \alpha^2\beta, \alpha\beta^2 \text{ which is the required answer.}$$

Alternate Solution

Since, $a^3x^2 + abcx + c^3 = 0$

$$\Rightarrow x = \frac{-abc \pm \sqrt{(abc)^2 - 4 \cdot a^3 \cdot c^3}}{2a^3}$$

$$\Rightarrow x = \frac{-(bla)(cla) \pm \sqrt{(bla)^2(cla)^2 - 4(cla)^3}}{2}$$

$$\Rightarrow x = \frac{(\alpha + \beta)(\alpha\beta) \pm \sqrt{(\alpha + \beta)^2(\alpha\beta)^2 - 4(\alpha\beta)^3}}{2}$$

$$\Rightarrow x = \frac{(\alpha + \beta)(\alpha\beta) \pm \alpha\beta\sqrt{(\alpha + \beta)^2 - 4\alpha\beta}}{2}$$

$$\Rightarrow x = \alpha\beta \left[\frac{(\alpha + \beta) \pm \sqrt{(\alpha + \beta)^2 - 4\alpha\beta}}{2} \right]$$

$$\Rightarrow x = \alpha\beta \left[\frac{(\alpha + \beta) \pm (\alpha - \beta)}{2} \right]$$

$$\Rightarrow x = \alpha\beta \left[\frac{\alpha + \beta + \alpha - \beta}{2}, \frac{\alpha + \beta - \alpha + \beta}{2} \right]$$

$$\Rightarrow x = \alpha\beta \left[\frac{2\alpha}{2}, \frac{2\beta}{2} \right]$$

$$\Rightarrow x = \alpha^2\beta, \alpha\beta^2 \text{ which is the required answer.}$$

Topic 4 Graph of Quadratic Expression

- Given parabola is $y^2 = 4x$,
 Since, X lies on the parabola, so let the coordinates of X be $(t^2, 2t)$. Thus, the coordinates of the vertices of the triangle PXQ are $P(4, -4)$, $X(t^2, 2t)$ and $Q(9, 6)$.

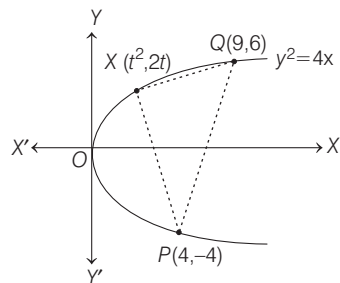

$$\therefore \text{Area of } \Delta PXQ = \frac{1}{2} \begin{vmatrix} 4 & -4 & 1 \\ t^2 & 2t & 1 \\ 9 & 6 & 1 \end{vmatrix}$$

$$= \frac{1}{2} | [4(2t - 6) + 4(t^2 - 9) + 1(6t^2 - 18t)] |$$

$$= \frac{1}{2} | [8t - 24 + 4t^2 - 36 + 6t^2 - 18t] |$$

$$= | 5t^2 - 5t - 30 | = | 5(t + 2)(t - 3) |$$

Now, as X is any point on the arc POQ of the parabola, therefore ordinate of point X , $2t \in (-4, 6) \Rightarrow t \in (-2, 3)$.
 \therefore Area of $\Delta PXQ = -5(t + 2)(t - 3) = -5t^2 + 5t + 30$
 $[\because |x - a| = -(x - a), \text{ if } x < a]$

The maximum area (in square units)

$$= - \left[\frac{25 - 4(-5)(30)}{4(-5)} \right] = \frac{125}{4}$$

$[\because \text{Maximum value of quadratic expression } ax^2 + bx + c, \text{ when } a < 0 \text{ is } -\frac{D}{4a}]$

- Let $f(x) = (c - 5)x^2 - 2cx + (c - 4) = 0$.
 Then, according to problem, the graph of $y = f(x)$ will be either of the two ways, shown below.

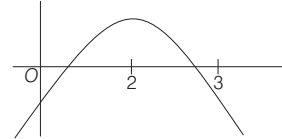
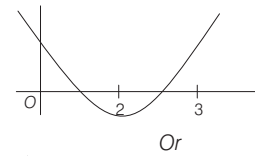

In both cases $f(0) \cdot f(2) < 0$ and $f(2)f(3) < 0$

Now, consider $f(0)f(2) < 0$

$$\Rightarrow (c - 4) [4(c - 5) - 4c + (c - 4)] < 0$$

$$\Rightarrow (c - 4)(c - 24) < 0$$

$$\Rightarrow c \in (4, 24) \quad \dots (i)$$

$$\begin{array}{c} + \quad - \quad + \\ | \quad | \quad | \\ 4 \quad 24 \end{array}$$

Similarly, $f(2) \cdot f(3) < 0$

$$\Rightarrow [4(c - 5) - 4c + (c - 4)] [9(c - 5) - 6c + (c - 4)] < 0$$

$$\Rightarrow (c - 24)(4c - 49) < 0$$

$$\begin{array}{c} + \quad - \quad + \\ | \quad | \quad | \\ 49/4 \quad 24 \end{array}$$

$$\Rightarrow c \in \left(\frac{49}{4}, 24 \right) \quad \dots (ii)$$

From Eqs. (i) and (ii), we get $c \in \left(\frac{49}{4}, 24 \right)$.
 \therefore Integral values of c are 13, 14,, 23.
 Thus, 11 integral values of c are possible.

46 Theory of Equations

3. According to given information, we have the following graph

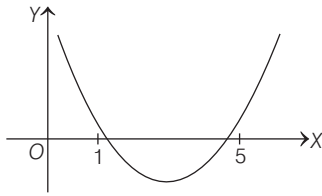

Now, the following conditions should satisfy

- (i) $D > 0 \Rightarrow b^2 - 4ac > 0$
 $\Rightarrow m^2 - 4 \times 1 \times 4 > 0$
 $\Rightarrow m^2 - 16 > 0$
 $\Rightarrow (m - 4)(m + 4) > 0$
 $\Rightarrow m \in (-\infty, -4) \cup (4, \infty)$
- (ii) The vertex of the parabola should lie between $x = 1$ and $x = 5$
 $\therefore -\frac{b}{2a} \in (1, 5) \Rightarrow 1 < \frac{m}{2} < 5 \Rightarrow m \in (2, 10)$
- (iii) $f(1) > 0 \Rightarrow 1 - m + 4 > 0$
 $\Rightarrow m < 5 \Rightarrow m \in (-\infty, 5)$
- (iv) $f(5) > 0 \Rightarrow 25 - 5m + 4 > 0$
 $\Rightarrow 5m < 29 \Rightarrow m \in \left(-\infty, \frac{29}{5}\right)$

From the values of m obtained in (i), (ii), (iii) and (iv), we get $m \in (4, 5)$.

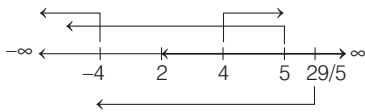

4. Put $t = x - [x] = \{X\}$, which is a fractional part function and lie between $0 \leq \{X\} < 1$ and then solve it.
 Given, $a \in R$ and equation is

$$-3\{x - [x]\}^2 + 2\{x - [x]\} + a^2 = 0$$

Let $t = x - [x]$, then equation is

$$-3t^2 + 2t + a^2 = 0$$

$$\Rightarrow t = \frac{1 \pm \sqrt{1 + 3a^2}}{3}$$

$\therefore t = x - [x] = \{X\}$ [fractional part]

$$\therefore 0 \leq t < 1$$

$$0 \leq \frac{1 \pm \sqrt{1 + 3a^2}}{3} < 1$$

Taking positive sign, we get

$$0 \leq \frac{1 + \sqrt{1 + 3a^2}}{3} < 1 \quad [\because \{x\} > 0]$$

$$\Rightarrow \sqrt{1 + 3a^2} < 2 \Rightarrow 1 + 3a^2 < 4$$

$$\Rightarrow a^2 - 1 < 0 \Rightarrow (a + 1)(a - 1) < 0$$

$\therefore a \in (-1, 1)$, for no integer solution of a , we consider $(-1, 0) \cup (0, 1)$

5. As we know, $ax^2 + bx + c > 0$ for all $x \in R$, iff $a > 0$ and $D < 0$.

Given equation is $x^2 + 2ax + (10 - 3a) > 0, \forall x \in R$

$$\text{Now, } D < 0$$

$$\Rightarrow 4a^2 - 4(10 - 3a) < 0$$

$$\Rightarrow 4(a^2 + 3a - 10) < 0$$

$$\Rightarrow (a + 5)(a - 2) < 0 \Rightarrow a \in (-5, 2)$$

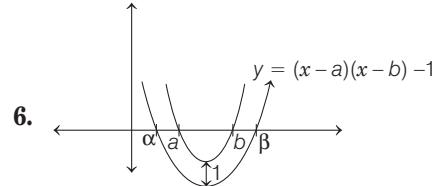

From graph, it is clear that one of the roots of $(x - a)(x - b) - 1 = 0$ lies in $(-\infty, a)$ and other lies in (b, ∞) .

7. Let $f(x) = x^2 - 2ax + a^2 + a - 3$

Since, both root are less than 3.

$$\Rightarrow \alpha < 3, \beta < 3$$

$$\Rightarrow \text{Sum, } S = \alpha + \beta < 6$$

$$\Rightarrow \frac{\alpha + \beta}{2} < 3$$

$$\Rightarrow \frac{2a}{2} < 3$$

$$\Rightarrow a < 3$$

Again, product, $P = \alpha\beta$

$$\Rightarrow P < 9 \Rightarrow \alpha\beta < 9$$

$$\Rightarrow a^2 + a - 3 < 9$$

$$\Rightarrow a^2 + a - 12 < 0$$

$$\Rightarrow (a - 3)(a + 4) < 0$$

$$\Rightarrow -4 < a < 3 \quad \dots(\text{ii})$$

Again, $D = B^2 - 4AC \geq 0$

$$\Rightarrow (-2a)^2 - 4 \cdot 1 \cdot (a^2 + a - 3) \geq 0$$

$$\Rightarrow 4a^2 - 4a^2 - 4a + 12 \geq 0$$

$$\Rightarrow -4a + 12 \geq 0 \Rightarrow a \leq 3 \quad \dots(\text{iii})$$

Again, $a f(3) > 0$

$$\Rightarrow 1 [(3)^2 - 2a(3) + a^2 + a - 3] > 0$$

$$\Rightarrow 9 - 6a + a^2 + a - 3 > 0$$

$$\Rightarrow a^2 - 5a + 6 > 0$$

$$\Rightarrow (a - 2)(a - 3) > 0$$

$$\therefore a \in (-\infty, 2) \cup (3, \infty) \quad \dots(\text{iv})$$

From Eqs. (i), (ii), (iii) and (iv), we get

$$a \in (-4, 2).$$

NOTE There is correction in answer $a < 2$ should be $-4 < a < 2$.

8. Let $f(x) = ax^2 + bx + c > 0, \forall x \in R$

$$\Rightarrow a > 0$$

$$\text{and } b^2 - 4ac < 0 \quad \dots(\text{i})$$

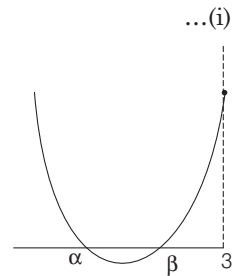

$\therefore g(x) = f(x) + f'(x) + f''(x)$
 $\Rightarrow g(x) = ax^2 + bx + c + 2ax + b + 2a$
 $\Rightarrow g(x) = ax^2 + x(b + 2a) + (c + b + 2a)$
 whose discriminant
 $= (b + 2a)^2 - 4a(c + b + 2a)$
 $= b^2 + 4a^2 + 4ab - 4ac - 4ab - 8a^2$
 $= b^2 - 4a^2 - 4ac = (b^2 - 4ac) - 4a^2 < 0$ [from Eq. (i)]
 $\therefore g(x) > 0 \forall x$, as $a > 0$ and discriminant < 0 .
 Thus, $g(x) > 0, \forall x \in R$.

9. Given,
 $x^2 + (a - b)x + (1 - a - b) = 0$ has real and unequal roots.
 $\Rightarrow D > 0$
 $\Rightarrow (a - b)^2 - 4(1)(1 - a - b) > 0$
 $\Rightarrow a^2 + b^2 - 2ab - 4 + 4a + 4b > 0$
 Now, to find the values of 'a' for which equation has unequal real roots for all values of b.
 i.e. Above equation is true for all b.
 or $b^2 + b(4 - 2a) + (a^2 + 4a - 4) > 0$, is true for all b.
 \therefore Discriminant, $D < 0$
 $\Rightarrow (4 - 2a)^2 - 4(a^2 + 4a - 4) < 0$
 $\Rightarrow 16 - 16a + 4a^2 - 4a^2 - 16a + 16 < 0$
 $\Rightarrow -32a + 32 < 0 \Rightarrow a > 1$

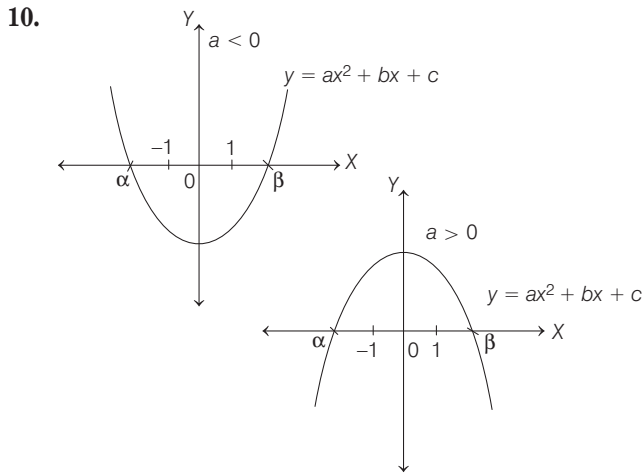

From figure, it is clear that, if $a > 0$, then $f(-1) < 0$ and $f(1) < 0$ and if $a < 0$, $f(-1) > 0$ and $f(1) > 0$. In both cases, $af(-1) < 0$ and $af(1) < 0$.

$\Rightarrow a(a - b + c) < 0$
 and $a(a + b + c) < 0$
 On dividing by a^2 , we get
 $1 - \frac{b}{a} + \frac{c}{a} < 0$ and $1 + \frac{b}{a} + \frac{c}{a} < 0$

On combining both, we get

$1 \pm \frac{b}{a} + \frac{c}{a} < 0$
 $\Rightarrow 1 + \left| \frac{b}{a} \right| + \frac{c}{a} < 0$

11. Since, $x^2 - 3x + 2 > 0$ and $x^2 - 2x - 4 \leq 0$
 $\Rightarrow (x - 1)(x - 2) > 0$ and $x^2 - 2x + 1 \leq 5$
 $\Rightarrow (x < 1 \text{ or } x > 2)$ and $(1 - \sqrt{5} \leq x \leq 1 + \sqrt{5})$
 $\therefore x \in [1 - \sqrt{5}, 1) \cup [1 + \sqrt{5}, 2)$
12. (i) Given, $x^2 - 8kx + 16(k^2 - k + 1) = 0$
 Now, $D = 64\{k^2 - (k^2 - k + 1)\} = 64(k - 1) > 0$
 $k > 1$
 (ii) $-\frac{b}{2a} > 4 \Rightarrow \frac{8k}{2} > 4 \Rightarrow k > 1$
 (iii) $f(4) \geq 0$
 $\Rightarrow 16 - 32k + 16(k^2 - k + 1) \geq 0$
 $\Rightarrow k^2 - 3k + 2 \geq 0$
 $\Rightarrow (k - 2)(k - 1) \geq 0$
 $\Rightarrow k \leq 1 \text{ or } k \geq 2$
 Hence, $k = 2$

Topic 5 Some Special Forms

1. Given equation $5 + |2^x - 1| = 2^x(2^x - 2)$

Case I

If $2^x - 1 \geq 0 \Rightarrow x \geq 0$,

then $5 + 2^x - 1 = 2^x(2^x - 2)$

Put $2^x = t$, then

$5 + t - 1 = t^2 - 2t \Rightarrow t^2 - 3t - 4 = 0$
 $\Rightarrow t^2 - 4t + t - 4 = 0 \Rightarrow t(t - 4) + 1(t - 4) = 0$
 $\Rightarrow t = 4 \text{ or } -1 \Rightarrow t = 4$ ($\because t = 2^x > 0$)
 $\Rightarrow 2^x = 4 \Rightarrow x = 2 > 0$
 $\Rightarrow x = 2$ is the solution.

Case II

If $2^x - 1 < 0 \Rightarrow x < 0$,

then $5 + 1 - 2^x = 2^x(2^x - 2)$

Put $2^x = y$, then $6 - y = y^2 - 2y$

$\Rightarrow y^2 - y - 6 = 0 \Rightarrow y^2 - 3y + 2y - 6 = 0$

$\Rightarrow (y + 2)(y - 3) = 0 \Rightarrow y = 3 \text{ or } -2$

$\Rightarrow y = 3$ (as $y = 2^x > 0$) $\Rightarrow 2^x = 3$

$\Rightarrow x = \log_2 3 > 0$

So, $x = \log_2 3$ is not a solution.

Therefore, number of real roots is one.

2. Given, inequality is

$2^{\sqrt{\sin^2 x - 2\sin x + 5}} \cdot \frac{1}{4^{\sin^2 y}} \leq 1$

$\Rightarrow 2^{\sqrt{(\sin x - 1)^2 + 4}} \cdot 2^{-2\sin^2 y} \leq 1$

$\Rightarrow 2^{\sqrt{(\sin x - 1)^2 + 4}} \leq 2^{2\sin^2 y}$

$\Rightarrow \sqrt{(\sin x - 1)^2 + 4} \leq 2\sin^2 y$

[if $a > 1$ and $a^m \leq a^n \Rightarrow m \leq n$]

\therefore Range of $\sqrt{(\sin x - 1)^2 + 4}$ is $[2, 2\sqrt{2}]$

and range of $2\sin^2 y$ is $[0, 2]$.

48 Theory of Equations

∴ The above inequality holds, iff

$$\sqrt{(\sin x - 1)^2 + 4} = 2 = 2 \sin^2 y$$

$$\Rightarrow \sin x = 1 \text{ and } \sin^2 y = 1$$

$$\Rightarrow \sin x = |\sin y| \quad [\text{from the options}]$$

3. **Key Idea** Reduce the given equation into quadratic equation.

Given equation is

$$|\sqrt{x} - 2| + \sqrt{x}(\sqrt{x} - 4) + 2 = 0$$

$$\Rightarrow |\sqrt{x} - 2| + x - 4\sqrt{x} + 4 = 2$$

$$\Rightarrow |\sqrt{x} - 2| + (\sqrt{x} - 2)^2 = 2$$

$$\Rightarrow (|\sqrt{x} - 2|)^2 + |\sqrt{x} - 2| - 2 = 0$$

Let $|\sqrt{x} - 2| = y$, then above equation reduced to

$$y^2 + y - 2 = 0 \Rightarrow y^2 + 2y - y - 2 = 0$$

$$\Rightarrow y(y + 2) - 1(y + 2) = 0 \Rightarrow (y + 2)(y - 1) = 0$$

$$\Rightarrow y = 1, -2$$

$$\therefore y = 1 \quad [\because y = |\sqrt{x} - 2| \geq 0]$$

$$\Rightarrow |\sqrt{x} - 2| = 1$$

$$\Rightarrow \sqrt{x} - 2 = \pm 1$$

$$\Rightarrow \sqrt{x} = 3 \text{ or } 1$$

$$\Rightarrow x = 9 \text{ or } 1$$

$$\therefore \text{Sum of roots} = 9 + 1 = 10$$

4. Let $f(x) = 2x^3 + 3x + k$

On differentiating w.r.t. x , we get

$$f'(x) = 6x^2 + 3 > 0, \forall x \in R$$

$\Rightarrow f(x)$ is strictly increasing function.

$\Rightarrow f(x) = 0$ has only one real root, so two roots are not possible.

5. Since, α is a root of $a^2x^2 + bx + c = 0$

$$\Rightarrow a^2\alpha^2 + b\alpha + c = 0 \quad \dots (i)$$

and β is a root of $a^2x^2 - bx - c = 0$

$$\Rightarrow a^2\beta^2 - b\beta - c = 0 \quad \dots (ii)$$

$$\text{Let } f(x) = a^2x^2 + 2bx + 2c$$

$$\begin{aligned} \therefore f(\alpha) &= a^2\alpha^2 + 2b\alpha + 2c \\ &= a^2\alpha^2 - 2a^2\alpha^2 = -a^2\alpha^2 \end{aligned} \quad [\text{from Eq. (i)}]$$

$$\begin{aligned} \text{and } f(\beta) &= a^2\beta^2 + 2b\beta + 2c \\ &= a^2\beta^2 + 2a^2\beta^2 = 3a^2\beta^2 \quad [\text{from Eq. (ii)}] \end{aligned}$$

$$\Rightarrow f(\alpha) f(\beta) < 0$$

$f(x)$ must have a root lying in the open interval (α, β) .

$$\therefore \alpha < \gamma < \beta$$

6. Let $f(x) = ax^3 + bx^2 + cx + d$... (i)

$$\begin{aligned} \therefore f(0) &= d \quad \text{and} \quad f(1) = a + b + c + d = d \\ & \quad [\because a + b + c = 0] \end{aligned}$$

$$\therefore f(0) = f(1)$$

f is continuous in the closed interval $[0, 1]$ and f is derivable in the open interval $(0, 1)$.

$$\text{Also, } f(0) = f(1).$$

∴ By Rolle's theorem, $f'(\alpha) = 0$ for $0 < \alpha < 1$

$$\text{Now, } f'(x) = 3ax^2 + 2bx + c$$

$$\Rightarrow f'(\alpha) = 3a\alpha^2 + 2b\alpha + c = 0$$

∴ Eq. (i) has exist atleast one root in the interval $(0, 1)$.

Thus, $f'(x)$ must have root in the interval $(0, 1)$ or $3ax^2 + 2bx + c = 0$ has root $\in (0, 1)$.

7. Given, $x^{12} - x^9 + x^4 - x + 1 > 0$

Here, three cases arises:

Case I When $x \leq 0 \Rightarrow x^{12} > 0, -x^9 > 0, x^4 > 0, -x > 0$

$$\therefore x^{12} - x^9 + x^4 - x + 1 > 0, \forall x \leq 0 \quad \dots (i)$$

Case II When $0 < x \leq 1$

$$x^9 < x^4 \text{ and } x < 1 \Rightarrow -x^9 + x^4 > 0 \text{ and } 1 - x > 0$$

$$\therefore x^{12} - x^9 + x^4 - x + 1 > 0, \forall 0 < x \leq 1 \quad \dots (ii)$$

Case III When $x > 1 \Rightarrow x^{12} > x^9$ and $x^4 > x$

$$\therefore x^{12} - x^9 + x^4 - x + 1 > 0, \forall x > 1 \quad \dots (iii)$$

From Eqs. (i), (ii) and (iii), the above equation holds for all $x \in R$.

8. Consider,

$$f(x) = \int_0^1 (1 + \cos^8 x)(ax^2 + bx + c) dx$$

Obviously, $f(x)$ is continuous and differentiable in the interval $[1, 2]$.

$$\text{Also, } f(1) = f(2) \quad [\text{given}]$$

∴ By Rolle's theorem, there exist atleast one point $k \in (1, 2)$, such that $f'(k) = 0$.

$$\text{Now, } f'(x) = (1 + \cos^8 x)(ax^2 + bx + c)$$

$$f'(k) = 0$$

$$\Rightarrow (1 + \cos^8 k)(ak^2 + bk + c) = 0$$

$$\Rightarrow ak^2 + bk + c = 0 \quad [\text{as } (1 + \cos^8 k) \neq 0]$$

$$\therefore x = k \text{ is root of } ax^2 + bx + c = 0,$$

where $k \in (1, 2)$

9. Given, x_1 and x_2 are roots of $\alpha x^2 - x + \alpha = 0$.

$$\therefore x_1 + x_2 = \frac{1}{\alpha} \text{ and } x_1 x_2 = 1$$

$$\text{Also, } |x_1 - x_2| < 1$$

$$\Rightarrow |x_1 - x_2|^2 < 1$$

$$\Rightarrow (x_1 - x_2)^2 < 1$$

$$\text{or } (x_1 + x_2)^2 - 4x_1 x_2 < 1$$

$$\Rightarrow \frac{1}{\alpha^2} - 4 < 1 \quad \text{or} \quad \frac{1}{\alpha^2} < 5$$

$$\Rightarrow 5\alpha^2 - 1 > 0 \quad \text{or} \quad (\sqrt{5}\alpha - 1)(\sqrt{5}\alpha + 1) > 0$$

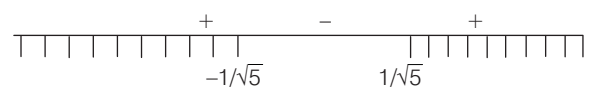

$$\therefore \alpha \in \left(-\infty, -\frac{1}{\sqrt{5}}\right) \cup \left(\frac{1}{\sqrt{5}}, \infty\right) \quad \dots (i)$$

Also, $D > 0$
 $\Rightarrow 1 - 4\alpha^2 > 0$
 or $\alpha \in \left(-\frac{1}{2}, \frac{1}{2}\right) \dots(ii)$

From Eqs. (i) and (ii), we get

$$\alpha \in \left(-\frac{1}{2}, \frac{-1}{\sqrt{5}}\right) \cup \left(\frac{1}{\sqrt{5}}, \frac{1}{2}\right)$$

10. PLAN

- (i) Concepts of curve tracing are used in this question.
- (ii) Number of roots are taken out from the curve traced.

Let $y = x^5 - 5x$

- (i) As $x \rightarrow \infty, y \rightarrow \infty$ and as $x \rightarrow -\infty, y \rightarrow -\infty$
- (ii) Also, at $x=0, y=0$, thus the curve passes through the origin.
- (iii) $\frac{dy}{dx} = 5x^4 - 5 = 5(x^4 - 1) = 5(x^2 - 1)(x^2 + 1)$

$$= 5(x-1)(x+1)(x^2+1)$$

$$\begin{array}{ccccccc} & + & & - & & + & \\ & & -1 & & 1 & & \\ & & & & & & \end{array}$$

Now, $\frac{dy}{dx} > 0$ in $(-\infty, -1) \cup (1, \infty)$, thus $f(x)$ is increasing in these intervals.

Also, $\frac{dy}{dx} < 0$ in $(-1, 1)$, thus decreasing in $(-1, 1)$.

- (iv) Also, at $x = -1, dy/dx$ changes its sign from +ve to -ve.
 $\therefore x = -1$ is point of local maxima.
 Similarly, $x = 1$ is point of local minima.
 Local maximum value, $y = (-1)^5 - 5(-1) = 4$
 Local minimum value, $y = (1)^5 - 5(1) = -4$

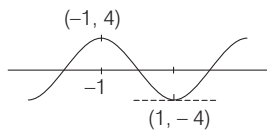

Now, let $y = -a$
 As evident from the graph, if $-a \in (-4, 4)$
 i.e. $a \in (-4, +4)$
 Then, $f(x)$ has three real roots and if $-a > 4$ or $-a < -4$, then $f(x)$ has one real root.
 i.e. for $a < -4$ or $a > 4, f(x)$ has one real root.

11. Given, $f(x) = 4x^3 + 3x^2 + 2x + 1$
 $f'(x) = 2(6x^2 + 3x + 1)$

$\Rightarrow D = 9 - 24 < 0$

Hence, $f(x) = 0$ has only one real root.

$$f\left(-\frac{1}{2}\right) = 1 - 1 + \frac{3}{4} - \frac{4}{8} > 0$$

$$f\left(-\frac{3}{4}\right) = 1 - \frac{6}{4} + \frac{27}{16} - \frac{108}{64}$$

$$= \frac{64 - 96 + 108 - 108}{64} < 0$$

$f(x)$ changes its sign in $\left(-\frac{3}{4}, -\frac{1}{2}\right)$

Hence, $f(x) = 0$ has a root in $\left(-\frac{3}{4}, -\frac{1}{2}\right)$.

12. $\int_0^{1/2} f(x) dx < \int_0^t f(x) dx < \int_0^{3/4} f(x) dx$

Now, $\int f(x) dx = \int (1 + 2x + 3x^2 + 4x^3) dx$
 $= x + x^2 + x^3 + x^4$

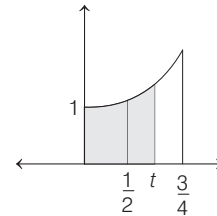

$\Rightarrow \int_0^{1/2} f(x) dx = \frac{15}{16} > \frac{3}{4}, \int_0^{3/4} f(x) dx = \frac{530}{256} < 3$

13. As, $f''(x) = 2(12x + 3)$

$f'(x) > 0$, when $x > -\frac{1}{4}$ and

$f'(x) < 0$, when $x < -\frac{1}{4}$.

\therefore It could be shown as

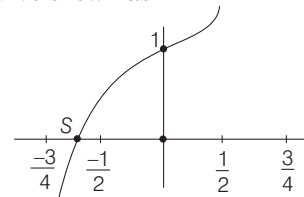

14. Let $y = x$ intersect the curve $y = ke^x$ at exactly one point when $k \leq 0$.

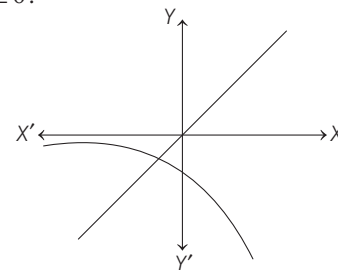

15. Let $f(x) = ke^x - x$
 $f'(x) = ke^x - 1 = 0$

$\Rightarrow x = -\ln k$

$f''(x) = ke^x$

$\therefore [f''(x)]_{x=-\ln k} = 1 > 0$

Hence, $f(-\ln k) = 1 + \ln k$

For one root of given equation

$1 + \ln k = 0$

$\Rightarrow k = \frac{1}{e}$

50 Theory of Equations

16. For two distinct roots, $1 + \ln k < 0$ ($k > 0$)

$$\ln k < -1 \Rightarrow k < \frac{1}{e}$$

Hence, $k \in \left(0, \frac{1}{e}\right)$

17. Let $f(x) = (x-a)(x-c) + 2(x-b)(x-d)$

Here, $f(a) = +ve$

$$f(b) = -ve$$

$$f(c) = -ve$$

$$f(d) = +ve$$

\therefore There exists two real and distinct roots one in the interval (a, b) and other in (c, d) .

Hence, statement is true.

18. Let $f(x) = 4x^3 - 3x - p$... (i)

$$\begin{aligned} \text{Now, } f\left(\frac{1}{2}\right) &= 4\left(\frac{1}{2}\right)^3 - 3\left(\frac{1}{2}\right) - p = \frac{4}{8} - \frac{3}{2} - p \\ &= -(1+p) \end{aligned}$$

$$f(1) = 4(1)^3 - 3(1) - p = 1 - p$$

$$\begin{aligned} \Rightarrow f\left(\frac{1}{2}\right) \cdot f(1) &= -(1+p)(1-p) \\ &= (p+1)(p-1) = p^2 - 1 \end{aligned}$$

Which is ≤ 0 , $\forall p \in [-1, 1]$.

$\therefore f(x)$ has atleast one root in $\left[\frac{1}{2}, 1\right]$.

$$\begin{aligned} \text{Now, } f'(x) &= 12x^2 - 3 = 3(2x-1)(2x+1) \\ &= \frac{3}{4}\left(x - \frac{1}{2}\right)\left(x + \frac{1}{2}\right) > 0 \text{ in } \left[\frac{1}{2}, 1\right] \end{aligned}$$

$\Rightarrow f(x)$ is an increasing function in $[1/2, 1]$

Therefore, $f(x)$ has exactly one root in $[1/2, 1]$ for any $p \in [-1, 1]$.

Now, let $x = \cos \theta$

$$\therefore x \in \left[\frac{1}{2}, 1\right] \Rightarrow \theta \in \left[0, \frac{\pi}{3}\right]$$

From Eq. (i),

$$\begin{aligned} 4 \cos^3 \theta - 3 \cos \theta &= p \\ \Rightarrow \cos 3\theta &= p \\ \Rightarrow 3\theta &= \cos^{-1} p \\ \Rightarrow \theta &= \frac{1}{3} \cos^{-1} p \\ \Rightarrow \cos \theta &= \cos\left(\frac{1}{3} \cos^{-1} p\right) \\ \Rightarrow x &= \cos\left(\frac{1}{3} \cos^{-1} p\right) \end{aligned}$$

3

Sequences and Series

Topic 1 Arithmetic Progression (AP)

Objective Questions I (Only one correct option)

- If $a_1, a_2, a_3, \dots, a_n$ are in AP and $a_1 + a_4 + a_7 + \dots + a_{16} = 114$, then $a_1 + a_6 + a_{11} + a_{16}$ is equal to
(2019 Main, 10 April I)
(a) 64 (b) 76
(c) 98 (d) 38
- If 19th term of a non-zero AP is zero, then its (49th term) : (29th term) is
(2019 Main, 11 Jan II)
(a) 1 : 3 (b) 4 : 1
(c) 2 : 1 (d) 3 : 1
- For any three positive real numbers a, b and c , if $9(25a^2 + b^2) + 25(c^2 - 3ac) = 15b(3a + c)$, then (2017 Main)
(a) b, c and a are in GP
(b) b, c and a are in AP
(c) a, b and c are in AP
(d) a, b and c are in GP
- If T_r is the r th term of an AP, for $r = 1, 2, 3, \dots$. If for some positive integers m and n , we have $T_m = \frac{1}{n}$ and $T_n = \frac{1}{m}$, then T_{mn} equals
(1998, 2M)
(a) $\frac{1}{mn}$ (b) $\frac{1}{m} + \frac{1}{n}$
(c) 1 (d) 0

Topic 2 Sum of n Terms of an AP

Objective Questions I (Only one correct option)

- If a_1, a_2, a_3, \dots are in AP such that $a_1 + a_7 + a_{16} = 40$, then the sum of the first 15 terms of this AP is
(2019 Main, 12 April II)
(a) 200 (b) 280
(c) 120 (d) 150
- Let S_n denote the sum of the first n terms of an AP. If $S_4 = 16$ and $S_6 = -48$, then S_{10} is equal to
(2019 Main, 12 April I)
(a) -260 (b) -410
(c) -320 (d) -380

Analytical and Descriptive Question

- If a_1, a_2, \dots, a_n are in arithmetic progression, where $a_i > 0, \forall i$, then show that
$$\frac{1}{\sqrt{a_1} + \sqrt{a_2}} + \frac{1}{\sqrt{a_2} + \sqrt{a_3}} + \dots + \frac{1}{\sqrt{a_{n-1}} + \sqrt{a_n}} = \frac{n-1}{\sqrt{a_1} + \sqrt{a_n}}$$

(1982, 2M)

True/False

- n_1, n_2, \dots, n_p are p positive integers, whose sum is an even number, then the number of odd integers among them is odd.
(1985, 1M)

Integer & Numerical Answer Type Questions

- Let $AP(a; d)$ denote the set of all the terms of an infinite arithmetic progression with first term a and common difference $d > 0$. If $AP(1; 3) \cap AP(2; 5) \cap AP(3; 7) = AP(a; d)$ then $a + d$ equals
(2019 Adv.)
- The sides of a right angled triangle are in arithmetic progression. If the triangle has area 24, then what is the length of its smallest side?
(2017 Adv.)

- For $x \in R$, let $[x]$ denote the greatest integer $\leq x$, then the sum of the series
$$\left[-\frac{1}{3} \right] + \left[-\frac{1}{3} - \frac{1}{100} \right] + \left[-\frac{1}{3} - \frac{2}{100} \right] + \dots + \left[-\frac{1}{3} - \frac{99}{100} \right]$$
 is
(2019 Main, 12 April I)
(a) -153 (b) -133
(c) -131 (d) -135
- If the sum and product of the first three terms in an AP are 33 and 1155, respectively, then a value of its 11th term is
(2019 Main, 9 April II)
(a) 25 (b) -36 (c) -25 (d) -35

52 Sequences and Series

5. Let the sum of the first n terms of a non-constant AP a_1, a_2, a_3, \dots be $50n + \frac{n(n-7)}{2}A$, where A is a constant.

If d is the common difference of this AP, then the ordered pair (d, a_{50}) is equal to (2019 Main, 9 April I)

- (a) $(A, 50 + 46A)$ (b) $(50, 50 + 45A)$
 (c) $(50, 50 + 46A)$ (d) $(A, 50 + 45A)$
6. The sum of all two digit positive numbers which when divided by 7 yield 2 or 5 as remainder is (2019 Main, 10 Jan I)
- (a) 1256 (b) 1465 (c) 1356 (d) 1365

7. Let a_1, a_2, \dots, a_{30} be an AP, $S = \sum_{i=1}^{30} a_i$ and

$$T = \sum_{i=1}^{15} a_{(2i-1)}. \text{ If } a_5 = 27 \text{ and } S - 2T = 75,$$

then a_{10} is equal to (2019 Main, 9 Jan I)

- (a) 42 (b) 57
 (c) 52 (d) 47
8. Let $b_i > 1$ for $i = 1, 2, \dots, 101$. Suppose $\log_e b_1, \log_e b_2, \dots, \log_e b_{101}$ are in AP with the common difference $\log_e 2$. Suppose a_1, a_2, \dots, a_{101} are in AP, such that $a_1 = b_1$ and $a_{51} = b_{51}$. If $t = b_1 + b_2 + \dots + b_{51}$ and $s = a_1 + a_2 + \dots + a_{51}$, then (2016 Adv.)
- (a) $s > t$ and $a_{101} > b_{101}$ (b) $s > t$ and $a_{101} < b_{101}$
 (c) $s < t$ and $a_{101} > b_{101}$ (d) $s < t$ and $a_{101} < b_{101}$

9. If the sum of first n terms of an AP is cn^2 , then the sum of squares of these n terms is (2009)

(a) $\frac{n(4n^2-1)c^2}{6}$ (b) $\frac{n(4n^2+1)c^2}{3}$
 (c) $\frac{n(4n^2-1)c^2}{3}$ (d) $\frac{n(4n^2+1)c^2}{6}$

10. If the sum of the first $2n$ terms of the AP series 2, 5, 8, ..., is equal to the sum of the first n terms of the AP series 57, 59, 61, ..., then n equals (2001, 1M)

- (a) 10 (b) 12
 (c) 11 (d) 13

Objective Question II

(One or more than one correct option)

11. If $S_n = \sum_{k=1}^{4n} (-1)^{\frac{k(k+1)}{2}} k^2$. Then, S_n can take value(s) (2013 Adv.)

- (a) 1056 (b) 1088
 (c) 1120 (d) 1332

Passage Based Problems

Read the following passage and answer the questions.

Passage

Let V_r denotes the sum of the first r terms of an arithmetic progression (AP) whose first term is r and the common difference is $(2r-1)$. Let $T_r = V_{r+1} - V_r$ and $Q_r = T_{r+1} - T_r$ for $r = 1, 2, \dots$ (2007, 8M)

12. The sum $V_1 + V_2 + \dots + V_n$ is

- (a) $\frac{1}{12}n(n+1)(3n^2-n+1)$
 (b) $\frac{1}{12}n(n+1)(3n^2+n+2)$
 (c) $\frac{1}{2}n(2n^2-n+1)$
 (d) $\frac{1}{3}(2n^3-2n+3)$

13. T_r is always

- (a) an odd number (b) an even number
 (c) a prime number (d) a composite number

14. Which one of the following is a correct statement ?

- (a) Q_1, Q_2, Q_3, \dots are in an AP with common difference 5
 (b) Q_1, Q_2, Q_3, \dots are in an AP with common difference 6
 (c) Q_1, Q_2, Q_3, \dots are in an AP with common difference 11
 (d) $Q_1 = Q_2 = Q_3 = \dots$

Fill in the Blanks

15. Let p and q be the roots of the equation $x^2 - 2x + A = 0$ and let r and s be the roots of the equation $x^2 - 18x + B = 0$. If $p < q < r < s$ are in arithmetic progression, then $A = \dots$ and $B = \dots$ (1997, 2M)

16. The sum of the first n terms of the series $1^2 + 2 \cdot 2^2 + 3^2 + 2 \cdot 4^2 + 5^2 + 2 \cdot 6^2 + \dots$ is $\frac{n(n+1)^2}{2}$, when n is even. When n is odd, the sum is (1988, 2M)

17. The sum of integers from 1 to 100 that are divisible by 2 or 5 is (1984, 2M)

Analytical & Descriptive Questions

18. The fourth power of the common difference of an arithmetic progression with integer entries is added to the product of any four consecutive terms of it. Prove that resulting sum is the square of an integer (2000, 4M)

19. The real numbers x_1, x_2, x_3 satisfying the equation $x^3 - x^2 + \beta x + \gamma = 0$ are in AP. Find the intervals in which β and γ lie. (1996, 3M)

20. The interior angles of a polygon are in arithmetic progression. The smallest angle is 120° and the common difference is 5° . Find the number of sides of the polygon. (1980, 3M)

Integer & Numerical Answer Type Questions

21. Suppose that all the terms of an arithmetic progression are natural numbers. If the ratio of the sum of the first seven terms to the sum of the first eleven terms is 6 : 11 and the seventh term lies in between 130 and 140, then the common difference of this AP is (2015 Adv.)

22. A pack contains n cards numbered from 1 to n . Two consecutive numbered cards are removed from the pack and the sum of the numbers on the remaining cards is 1224. If the smaller of the numbers on the removed cards is k , then $k - 20$ is equal to (2013 Adv.)

23. Let $a_1, a_2, a_3, \dots, a_{100}$ be an arithmetic progression with $a_1 = 3$ and $S_p = \sum_{i=1}^p a_i, 1 \leq p \leq 100$. For any integer n with $1 \leq n \leq 20$, let $m = 5n$. If $\frac{S_m}{S_n}$ does not depend on n , then a_2 is equal to
- (2011)
24. Let $a_1, a_2, a_3, \dots, a_{11}$ be real numbers satisfying $a_1 = 15, 27 - 2a_2 > 0$ and $a_k = 2a_{k-1} - a_{k-2}$ for $k = 3, 4, \dots, 11$. If $\frac{a_1^2 + a_2^2 + \dots + a_{11}^2}{a_1 + a_2 + \dots + a_{11}} = 90$, then the value of $\frac{11}{11}$ is.....
- (2010)

Topic 3 Geometric Progression (GP)

Objective Questions I (Only one correct option)

- Let a, b and c be in GP with common ratio r , where $a \neq 0$ and $0 < r \leq \frac{1}{2}$. If $3a, 7b$ and $15c$ are the first three terms of an AP, then the 4th term of this AP is
(2019 Main, 10 April II)
(a) $5a$ (b) $\frac{2}{3}a$ (c) a (d) $\frac{7}{3}a$
- If three distinct numbers a, b and c are in GP and the equations $ax^2 + 2bx + c = 0$ and $dx^2 + 2ex + f = 0$ have a common root, then which one of the following statements is correct?
(2019 Main, 8 April II)
(a) d, e and f are in GP (b) $\frac{d}{a}, \frac{e}{b}$ and $\frac{f}{c}$ are in AP
(c) d, e and f are in AP (d) $\frac{d}{a}, \frac{e}{b}$ and $\frac{f}{c}$ are in GP
- The product of three consecutive terms of a GP is 512. If 4 is added to each of the first and the second of these terms, the three terms now form an AP. Then, the sum of the original three terms of the given GP is
(2019 Main, 12 Jan I)
(a) 36 (b) 28 (c) 32 (d) 24
- Let a_1, a_2, \dots, a_{10} be a GP. If $\frac{a_3}{a_1} = 25$, then $\frac{a_9}{a_5}$ equals
(2019 Main, 11 Jan I)
(a) 5^3 (b) $2(5^2)$ (c) $4(5^2)$ (d) 5^4
- Let a, b and c be the 7th, 11th and 13th terms respectively of a non-constant AP. If these are also the three consecutive terms of a GP, then $\frac{a}{c}$ is equal to
(2019 Main, 9 Jan II)
(a) 2 (b) $\frac{7}{13}$ (c) 4 (d) $\frac{1}{2}$
- If a, b and c be three distinct real numbers in GP and $a + b + c = xb$, then x cannot be
(2019 Main, 9 Jan I)
(a) 4 (b) 2 (c) -2 (d) -3
- If the 2nd, 5th and 9th terms of a non-constant AP are in GP, then the common ratio of this GP is
(2016 Main)
(a) $\frac{8}{5}$ (b) $\frac{4}{3}$ (c) 1 (d) $\frac{7}{4}$
- Let $f(x) = ax^2 + bx + c, a \neq 0$ and $\Delta = b^2 - 4ac$. If $\alpha + \beta, \alpha^2 + \beta^2$ and $\alpha^3 + \beta^3$ are in GP, then
(2005, 1M)
(a) $\Delta \neq 0$ (b) $b\Delta = 0$ (c) $c\Delta = 0$ (d) $bc \neq 0$
- Let a, b, c be in an AP and a^2, b^2, c^2 be in GP. If $a < b < c$ and $a + b + c = \frac{3}{2}$, then the value of a is
(2002, 1M)
(a) $\frac{1}{2\sqrt{2}}$ (b) $\frac{1}{2\sqrt{3}}$ (c) $\frac{1}{2} - \frac{1}{\sqrt{3}}$ (d) $\frac{1}{2} - \frac{1}{\sqrt{2}}$
- Let α, β be the roots of $x^2 - x + p = 0$ and γ, δ be the roots of $x^2 - 4x + q = 0$. If $\alpha, \beta, \gamma, \delta$ are in GP, then the integer values of p and q respectively are
(2001, 1M)
(a) -2, -32 (b) -2, 3 (c) -6, 3 (d) -6, -32
- If a, b, c, d and p are distinct real numbers such that $(a^2 + b^2 + c^2)p^2 - 2(ab + bc + cd)p + (b^2 + c^2 + d^2) \leq 0$, then a, b, c, d
(a) are in AP (b) are in GP (1987, 2M)
(c) are in HP (d) satisfy $ab = cd$
- If a, b, c are in GP, then the equations $ax^2 + 2bx + c = 0$ and $dx^2 + 2ex + f = 0$ have a common root, if $\frac{d}{a}, \frac{e}{b}, \frac{f}{c}$ are in
(1985, 2M)
(a) AP (b) GP
(c) HP (d) None of these
- The third term of a geometric progression is 4. The product of the first five terms is
(1982, 2M)
(a) 4^3 (b) 4^5
(c) 4^4 (d) None of these

Analytical & Descriptive Questions

- Find three numbers a, b, c between 2 and 18 such that
(i) their sum is 25. (ii) the numbers $2, a, b$ are consecutive terms of an AP. (iii) the numbers $b, c, 18$ are consecutive terms of a GP.
(1983, 2M)
- Does there exist a geometric progression containing 27, 8 and 12 as three of its terms? If it exists, then how many such progressions are possible?
(1982, 2M)
- If the m th, n th and p th terms of an AP and GP are equal and are x, y, z , then prove that $x^{y-z} \cdot y^{z-x} \cdot z^{x-y} = 1$.
(1979, 3M)

Topic 4 Sum of n Terms & Infinite Terms of a GP

Objective Questions I (Only one correct option)

1. If $|x| < 1, |y| < 1$ and $x \neq y$, then the sum to infinity of the following series $(x+y) + (x^2+xy+y^2) + (x^3+x^2y+xy^2+y^3) + \dots$ is (2020 Main, 2 Sep I)

(a) $\frac{x+y+xy}{(1+x)(1+y)}$ (b) $\frac{x+y-xy}{(1-x)(1-y)}$
 (c) $\frac{x+y+xy}{(1-x)(1-y)}$ (d) $\frac{x+y-xy}{(1+x)(1+y)}$

2. The sum $\sum_{k=1}^{20} k \frac{1}{2^k}$ is equal to (2019 Main, 8 April II)

(a) $2 - \frac{11}{2^{19}}$ (b) $1 - \frac{11}{2^{20}}$
 (c) $2 - \frac{3}{2^{17}}$ (d) $2 - \frac{21}{2^{20}}$

3. Let $S_n = 1 + q + q^2 + \dots + q^n$ and $T_n = 1 + \left(\frac{q+1}{2}\right) + \left(\frac{q+1}{2}\right)^2 + \dots + \left(\frac{q+1}{2}\right)^n$, where q is a real number and $q \neq 1$. If ${}^{101}C_1 + {}^{101}C_2 \cdot S_1 + \dots + {}^{101}C_{101} \cdot S_{100} = \alpha T_{100}$, then α is equal to (2019 Main, 11 Jan II)

(a) 2^{100} (b) 202
 (c) 200 (d) 2^{99}

4. The sum of an infinite geometric series with positive terms is 3 and the sum of the cubes of its terms is $\frac{27}{19}$.

Then, the common ratio of this series is (2019 Main, 11 Jan I)

(a) $\frac{4}{9}$ (b) $\frac{2}{3}$ (c) $\frac{2}{9}$ (d) $\frac{1}{3}$

5. Three positive numbers form an increasing GP. If the middle term in this GP is doubled, then new numbers are in AP. Then, the common ratio of the GP is (2014 Main)

(a) $\sqrt{2} + \sqrt{3}$ (b) $3 + \sqrt{2}$
 (c) $2 - \sqrt{3}$ (d) $2 + \sqrt{3}$

6. If $(10)^9 + 2(11)^1(10)^8 + 3(11)^2(10)^7 + \dots + 10(11)^9 = k(10)^9$, then k is equal to (2014 Main)

(a) $\frac{121}{10}$ (b) $\frac{441}{100}$ (c) 100 (d) 110

7. The sum of first 20 terms of the sequence $0.7, 0.77, 0.777, \dots$, is (2013 Main)

(a) $\frac{7}{81}(179 - 10^{-20})$ (b) $\frac{7}{9}(99 - 10^{-20})$
 (c) $\frac{7}{81}(179 + 10^{-20})$ (d) $\frac{7}{9}(99 + 10^{-20})$

8. An infinite GP has first term x and sum 5, then x belongs to (2004, 1M)

(a) $x < -10$ (b) $-10 < x < 0$ (c) $0 < x < 10$ (d) $x > 10$

9. Consider an infinite geometric series with first term a and common ratio r . If its sum is 4 and the second term is $3/4$, then (2000, 2M)

(a) $a = 4/7, r = 3/7$ (b) $a = 2, r = 3/8$
 (c) $a = 3/2, r = 1/2$ (d) $a = 3, r = 1/4$

10. Sum of the first n terms of the series $\frac{1}{2} + \frac{3}{4} + \frac{7}{8} + \frac{15}{16} + \dots$ is equal to (1988, 2M)

(a) $2^n - n - 1$ (b) $1 - 2^{-n}$ (c) $n + 2^{-n} - 1$ (d) $2^n + 1$

Objective Question II

(One or more than one correct option)

11. Let α and β be the roots of $x^2 - x - 1 = 0$, with $\alpha > \beta$. For all positive integers n , define

$$a_n = \frac{\alpha^n - \beta^n}{\alpha - \beta}, n \geq 1,$$

$$b_1 = 1 \text{ and } b_n = a_{n-1} + a_{n+1}, n \geq 2$$

Then which of the following options is/are correct?

(a) $\sum_{n=1}^{\infty} \frac{b_n}{10^n} = \frac{8}{89}$ (2019 Adv.)

(b) $b_n = \alpha^n + \beta^n$ for all $n \geq 1$

(c) $a_1 + a_2 + a_3 + \dots + a_n = a_{n+2} - 1$ for all $n \geq 1$

(d) $\sum_{n=1}^{\infty} \frac{a_n}{10^n} = \frac{10}{89}$

12. Let S_1, S_2, \dots be squares such that for each $n \geq 1$ the length of a side of S_n equals the length of a diagonal of S_{n+1} . If the length of a side of S_1 is 10 cm, then for which of the following values of n is the area of S_n less than 1 sq cm? (1999, 3M)

(a) 7 (b) 8 (c) 9 (d) 10

Analytical & Descriptive Questions

13. Let $A_n = \left(\frac{3}{4}\right) - \left(\frac{3}{4}\right)^2 + \left(\frac{3}{4}\right)^3 + \dots + (-1)^{n-1} \left(\frac{3}{4}\right)^n$,

$B_n = 1 - A_n$. Find a least odd natural number n_0 , so that $B_n > A_n, \forall n \geq n_0$. (2006, 6M)

14. If $S_1, S_2, S_3, \dots, S_n$ are the sums of infinite geometric series, whose first terms are 1, 2, 3, ..., n and whose common ratios are $\frac{1}{2}, \frac{1}{3}, \frac{1}{4}, \dots, \frac{1}{n+1}$ respectively, then find the values of $S_1^2 + S_2^2 + S_3^2 + \dots + S_{2n-1}^2$. (1991, 4M)

15. The sum of the squares of three distinct real numbers, which are in GP, is S^2 . If their sum is αS , then show that

$$\alpha^2 \in \left(\frac{1}{3}, 1\right) \cup (1, 3) \quad (1986, 5M)$$

Integer & Numerical Answer Type Question

16. Let S_k , where $k = 1, 2, \dots, 100$, denotes the sum of the infinite geometric series whose first term is $\frac{k-1}{k!}$ and

the common ratio is $\frac{1}{k}$. Then, the value of

$$\frac{100^2}{100!} + \sum_{k=1}^{100} |(k^2 - 3k + 1) S_k| \text{ is } \dots \quad (2010)$$

Topic 5 Harmonic Progression (HP)

Objective Questions I (Only one correct option)

- If a_1, a_2, a_3, \dots are in a harmonic progression with $a_1 = 5$ and $a_{20} = 25$. Then, the least positive integer n for which $a_n < 0$, is (2012)
 - 22
 - 23
 - 24
 - 25
- If the positive numbers a, b, c, d are in AP. Then, abc, abd, acd, bcd are (2001, 1M)
 - not in AP/GP/HP
 - in AP
 - in GP
 - in HP
- Let a_1, a_2, \dots, a_{10} be in AP and h_1, h_2, \dots, h_{10} be in HP. If $a_1 = h_1 = 2$ and $a_{10} = h_{10} = 3$, then $a_4 h_7$ is (1999, 2M)
 - 2
 - 3
 - 5
 - 6
- If $x > 1, y > 1, z > 1$ are in GP, then $\frac{1}{1 + \ln x}, \frac{1}{1 + \ln y}, \frac{1}{1 + \ln z}$ are in (1998, 2M)
 - AP
 - HP
 - GP
 - None of these

Assertion and Reason

For the following question, choose the correct answer from the codes (a), (b), (c) and (d) defined as follows:

- Statement I is true, Statement II is also true; Statement II is the correct explanation of Statement I
- Statement I is true, Statement II is also true; Statement II is not the correct explanation of Statement I
- Statement I is true; Statement II is false
- Statement I is false; Statement II is true

- Suppose four distinct positive numbers a_1, a_2, a_3, a_4 are in GP. Let $b_1 = a_1, b_2 = b_1 + a_2, b_3 = b_2 + a_3$ and $b_4 = b_3 + a_4$.

Statement I The numbers b_1, b_2, b_3, b_4 are neither in AP nor in GP.

Statement II The numbers b_1, b_2, b_3, b_4 are in HP.

(2008, 3M)

Fill in the Blank

- If $\cos(x - y), \cos x$ and $\cos(x + y)$ are in HP. Then $\cos x \cdot \sec\left(\frac{y}{2}\right) = \dots$ (1997C, 2M)

Analytical & Descriptive Questions

- If a, b, c are in AP, a^2, b^2, c^2 are in HP, then prove that either $a = b = c$ or $a, b, -\frac{c}{2}$ form a GP. (2003, 4M)
- Let a and b be positive real numbers. If a, A_1, A_2, b are in arithmetic progression, a, G_1, G_2, b are in geometric progression and a, H_1, H_2, b are in harmonic progression, then show that

$$\frac{G_1 G_2}{H_1 H_2} = \frac{A_1 + A_2}{H_1 + H_2} = \frac{(2a + b)(a + 2b)}{9ab}$$
 (2002, 5M)
- (i) The value of $x + y + z$ is 15. If a, x, y, z, b are in AP while the value of $\frac{1}{x} + \frac{1}{y} + \frac{1}{z}$ is $\frac{5}{3}$. If a, x, y, z, b are in HP, then find a and b .
 (ii) If x, y, z are in HP, then show that $\log(x + z) + \log(x + z - 2y) = 2 \log(x - z)$. (1978, 3M)

Topic 6 Relation between AM, GM, HM and Some Special Series

Objective Questions I (Only one correct option)

- The sum of series $1 + \frac{1^3 + 2^3}{1 + 2} + \frac{1^3 + 2^3 + 3^3}{1 + 2 + 3} + \dots + \frac{1^3 + 2^3 + 3^3 + \dots + 15^3}{1 + 2 + 3 + \dots + 15} - \frac{1}{2}(1 + 2 + 3 + \dots + 15)$ is equal to (2019 Main, 10 April II)
 - 620
 - 660
 - 1240
 - 1860
- The sum of series $\frac{3 \times 1^3}{1^2} + \frac{5 \times (1^3 + 2^3)}{1^2 + 2^2} + \frac{7 \times (1^3 + 2^3 + 3^3)}{1^2 + 2^2 + 3^2} + \dots$ upto 10th term, is (2019 Main, 10 April I)
 - 680
 - 600
 - 660
 - 620
- The sum of the series $1 + 2 \times 3 + 3 \times 5 + 4 \times 7 + \dots$ upto 11th term is (2019 Main, 9 April II)
 - 915
 - 946
 - 916
 - 945

- If the sum of the first 15 terms of the series

$$\left(\frac{3}{4}\right)^3 + \left(1\frac{1}{2}\right)^3 + \left(2\frac{1}{4}\right)^3 + 3^3 + \left(3\frac{3}{4}\right)^3 + \dots$$

is equal to $225k$, then k is equal to

(2019 Main, 12 Jan II)

- 108
- 27
- 54
- 9

- Let $S_k = \frac{1 + 2 + 3 + \dots + k}{k}$. If $S_1^2 + S_2^2 + \dots + S_{10}^2 = \frac{5}{12}A$, then A is equal to (2019 Main, 12 Jan I)
 - 156
 - 301
 - 283
 - 303

- Let x, y be positive real numbers and m, n positive integers. The maximum value of the expression

$$\frac{x^m y^n}{(1 + x^{2m})(1 + y^{2n})}$$
 is

(2019 Main, 11 Jan II)

- $\frac{1}{2}$
- 1
- $\frac{1}{4}$
- $\frac{m + n}{6mn}$

56 Sequences and Series

7. The sum of the following series

$$1 + 6 + \frac{9(1^2 + 2^2 + 3^2)}{7} + \frac{12(1^2 + 2^2 + 3^2 + 4^2)}{9} + \frac{15(1^2 + 2^2 + \dots + 5^2)}{11} + \dots \text{ up to 15 terms is}$$

(2019 Main, 9 Jan II)

- (a) 7510 (b) 7820 (c) 7830 (d) 7520

8. Let $a_1, a_2, a_3, \dots, a_{49}$ be in AP such that $\sum_{k=0}^{12} a_{4k+1} = 416$

and $a_9 + a_{43} = 66$. If $a_1^2 + a_2^2 + \dots + a_{17}^2 = 140m$, then m is equal to (2018 Main)

- (a) 66 (b) 68 (c) 34 (d) 33

9. Let A be the sum of the first 20 terms and B be the sum of the first 40 terms of the series

$$1^2 + 2 \cdot 2^2 + 3^2 + 2 \cdot 4^2 + 5^2 + 2 \cdot 6^2 + \dots$$

If $B - 2A = 100\lambda$, then λ is equal to (2018 Main)

- (a) 232 (b) 248 (c) 464 (d) 496

10. If the sum of the first ten terms of the series

$$\left(1 \frac{3}{5}\right)^2 + \left(2 \frac{2}{5}\right)^2 + \left(3 \frac{1}{5}\right)^2 + 4^2 + \left(4 \frac{4}{5}\right)^2 + \dots, \text{ is } \frac{16}{5}m, \text{ then}$$

m is equal to (2016 Main)

- (a) 102 (b) 101 (c) 100 (d) 99

11. If m is the AM of two distinct real numbers l and n ($l, n > 1$) and G_1, G_2 and G_3 are three geometric means between l and n , then $G_1^4 + 2G_2^4 + G_3^4$ equals (2015)

- (a) $4l^2mn$ (b) $4lm^2n$ (c) lmn^2 (d) $l^2m^2n^2$

12. The sum of first 9 terms of the series $\frac{1^3}{1} + \frac{1^3 + 2^3}{1+3} + \frac{1^3 + 2^3 + 3^3}{1+3+5} + \dots$ is (2015)

- (a) 71 (b) 96 (c) 142 (d) 192

13. If $\alpha \in \left(0, \frac{\pi}{2}\right)$, then $\sqrt{x^2 + x} + \frac{\tan^2 \alpha}{\sqrt{x^2 + x}}$ is always greater

than or equal to (2003, 2M)

- (a) $2 \tan \alpha$ (b) 1 (c) 2 (d) $\sec^2 \alpha$

14. If a_1, a_2, \dots, a_n are positive real numbers whose product is a fixed number c , then the minimum value of $a_1 + a_2 + \dots + a_{n-1} + 2a_n$ is (2002, 1M)

- (a) $n(2c)^{1/n}$ (b) $(n+1)c^{1/n}$
(c) $2nc^{1/n}$ (d) $(n+1)(2c)^{1/n}$

15. If a, b, c are positive real numbers such that $a + b + c + d = 2$, then $M = (a + b)(c + d)$ satisfies the relation (2000, 2M)

- (a) $0 < M \leq 1$ (b) $1 \leq M \leq 2$ (c) $2 \leq M \leq 3$ (d) $3 \leq M \leq 4$

16. The harmonic mean of the roots of the equation

$$(5 + \sqrt{2})x^2 - (4 + \sqrt{5})x + 8 + 2\sqrt{5} = 0 \text{ is (1999, 2M)}$$

- (a) 2 (b) 4
(c) 6 (d) 8

17. The product of n positive numbers is unity, then their sum is (1991, 2M)

- (a) a positive integer (b) divisible by n
(c) equal to $n + \frac{1}{n}$ (d) never less than n

18. If a, b and c are distinct positive numbers, then the expression $(b + c - a)(c + a - b)(a + b - c) - abc$ is

- (a) positive (b) negative (1991, 2M)
(c) non-positive (d) non-negative

19. If x_1, x_2, \dots, x_n are any real numbers and n is any positive integer, then (1982, 1M)

- (a) $n \sum_{i=1}^n x_i^2 < \left(\sum_{i=1}^n x_i\right)^2$ (b) $n \sum_{i=1}^n x_i^2 \geq \left(\sum_{i=1}^n x_i\right)^2$
(c) $n \sum_{i=1}^n x_i^2 \geq n \left(\sum_{i=1}^n x_i\right)^2$ (d) None of these

Passage Based Problems

Passage

Let A_1, G_1, H_1 denote the arithmetic, geometric and harmonic means, respectively, of two distinct positive numbers. For $n \geq 2$, let A_{n-1} and H_{n-1} has arithmetic, geometric and harmonic means as A_n, G_n, H_n , respectively. (2007, 8M)

20. Which one of the following statements is correct?

- (a) $G_1 > G_2 > G_3 > \dots$
(b) $G_1 < G_2 < G_3 < \dots$
(c) $G_1 = G_2 = G_3 = \dots$
(d) $G_1 < G_3 < G_5 < \dots$ and $G_2 > G_4 > G_6 > \dots$

21. Which of the following statements is correct?

- (a) $A_1 > A_2 > A_3 > \dots$
(b) $A_1 < A_2 < A_3 < \dots$
(c) $A_1 > A_3 > A_5 > \dots$ and $A_2 < A_4 < A_6 < \dots$
(d) $A_1 < A_3 < A_5 < \dots$ and $A_2 > A_4 > A_6 > \dots$

22. Which of the following statements is correct ?

- (a) $H_1 > H_2 > H_3 > \dots$
(b) $H_1 < H_2 < H_3 < \dots$
(c) $H_1 > H_3 > H_5 > \dots$ and $H_2 < H_4 < H_6 < \dots$
(d) $H_1 < H_3 < H_5 < \dots$ and $H_2 > H_4 > H_6 > \dots$

Objective Questions II

(One or more than one correct option)

23. For a positive integer n let

$$a(n) = 1 + \frac{1}{2} + \frac{1}{3} + \frac{1}{4} + \dots + \frac{1}{(2^n) - 1}, \text{ then (1999, 3M)}$$

- (a) $a(100) \leq 100$ (b) $a(100) > 100$
(c) $a(200) \leq 100$ (d) $a(200) > 100$

24. If the first and the $(2n - 1)$ th term of an AP, GP and HP are equal and their n th terms are a, b and c respectively, then (1988, 2M)

- (a) $a = b = c$ (b) $a \geq b \geq c$
(c) $a + c = b$ (d) $ac - b^2 = 0$

Fill in the Blanks

25. If x be is the arithmetic mean and y, z be two geometric means between any two positive numbers, then

$$\frac{y^3 + z^3}{xyz} = \dots$$

(1997C, 2M)

26. If the harmonic mean and geometric mean of two positive numbers are in the ratio 4 : 5. Then, the two numbers are in the ratio ... (1992, 2M)

True/False

27. If x and y are positive real numbers and m, n are any positive integers, then $\frac{x^n y^m}{(1+x^{2n})(1+y^{2m})} > \frac{1}{4}$. (1989, 1M)

28. For $0 < a < x$, the minimum value of function $\log_a x + \log_x a$ is 2.

Analytical & Descriptive Questions

29. If a, b, c are positive real numbers, then prove that $\{(1+a)(1+b)(1+c)\}^7 > 7^7 a^4 b^4 c^4$ (2004, 4M)
30. Let a_1, a_2, \dots be positive real numbers in geometric progression. For each n , if A_n, G_n, H_n are respectively, the arithmetic mean, geometric mean and harmonic mean of a_1, a_2, \dots, a_n . Then, find an expression for the geometric mean of G_1, G_2, \dots, G_n in terms of $A_1, A_2, \dots, A_n, H_1, H_2, \dots, H_n$. (2001, 5M)
31. If p is the first of the n arithmetic means between two numbers and q be the first on n harmonic means between the same numbers. Then, show that q does not lie between p and $\left(\frac{n+1}{n-1}\right)^2 p$. (1991, 4M)

32. If $a > 0, b > 0$ and $c > 0$, then prove that

$$(a + b + c) \frac{1}{a} + \frac{1}{b} + \frac{1}{c} \geq 9 \quad (1984, 2M)$$

Integer & Numerical Answer Type Questions

33. Let m be the minimum possible value of $\log_3(3^{y_1} + 3^{y_2} + 3^{y_3})$, where y_1, y_2, y_3 are real numbers for which $y_1 + y_2 + y_3 = 9$. Let M be the maximum possible value of $(\log_3 x_1 + \log_3 x_2 + \log_3 x_3)$, where x_1, x_2, x_3 are positive real numbers for which $x_1 + x_2 + x_3 = 9$. Then the value of $\log_2(m^3) + \log_3(M^2)$ is (2020 Adv.)
34. Let a_1, a_2, a_3, \dots be a sequence of positive integers in arithmetic progression with common difference 2. Also, let b_1, b_2, b_3, \dots be a sequence of positive integers in geometric progression with common ratio 2. If $a_1 = b_1 = c$, then the number of all possible values of c , for which the equality $2(a_1 + a_2 + \dots + a_n) = b_1 + b_2 + \dots + b_n$ holds for some positive integer n , is (2020 Adv.)
35. If m arithmetic means (AMs) and three geometric means (GMs) are inserted between 3 and 243 such that 4th AM is equal to 2nd GM, then m is equal to [2020 Main, 3 Sep III]
36. Let a, b, c be positive integers such that b/a is an integer. If a, b, c are in geometric progression and the arithmetic mean of a, b, c is $b + 2$, then the value of $\frac{a^2 + a - 14}{a + 1}$ is (2014 Adv.)
37. The minimum value of the sum of real numbers $a^{-5}, a^{-4}, 3a^{-3}, 1, a^8$ and a^{10} with $a > 0$ is (2011)

Answers

Topic 1

1. (b) 2. (d) 3. (b) 4. (c)
6. False 7. (157.00) 8. (6)

Topic 2

1. (a) 2. (c) 3. (b) 4. (c)
5. (a) 6. (c) 7. (c) 8. (b)
9. (c) 10. (c) 11. (a, d) 12. (b)
13. (d) 14. (b) 15. $A = -3, B = 77$

16. $\left[\frac{n^2(n+1)}{2} \right]$ 17. 3050

19. $\beta \in \left[-\infty, \frac{1}{3} \right]$ and $\gamma \in \left[-\frac{1}{27}, \infty \right]$ 20. (9) 21. (9)

22. (5) 23. (9) 24. (0)

Topic 3

1. (c) 2. (b) 3. (b) 4. (d)
5. (c) 6. (b) 7. (b) 8. (c)
9. (d) 10. (a) 11. (b) 12. (a)
13. (b)
14. $(a = 5) (b = 8) (c = 12)$ 15. Yes, infinite

Topic 4

1. (b) 2. (a) 3. (a) 4. (b)
5. (d) 6. (c) 7. (c) 8. (c)
9. (d) 10. (c) 11. (b, c, d) 12. (b,c,d)
13. (7) 14. $\frac{1}{6}(2n)(2n+1)(4n+1) - 1$ 16. (4)

Topic 5

1. (d) 2. (d) 3. (d) 4. (b)
5. (c) 6. $\pm\sqrt{2}$ 9. (i) $a = 1, b = 9$

Topic 6

1. (a) 2. (c) 3. (b) 4. (b)
5. (d) 6. (c) 7. (b) 8. (c)
9. (b) 10. (b) 11. (b) 12. (b)
13. (a) 14. (a) 15. (a) 16. (b)
17. (d) 18. (b) 19. (b) 20. (c)
21. (a) 22. (b) 23. (a, d) 24. (a, b, d)
25. 2 26. 4 : 1 27. False 28. False
33. (8) 34. $C = 12$ for $n = 3$ 35. (39)
36. (4) 37. (8)

Hints & Solutions

Topic 1 Arithmetic Progression (AP)

1. **Key Idea** Use n th term of an AP i.e. $a_n = a + (n-1)d$, simplify the given equation and use result.

Given AP is $a_1, a_2, a_3, \dots, a_n$

Let the above AP has common difference ' d ', then
 $a_1 + a_4 + a_7 + \dots + a_{16}$

$$= a_1 + (a_1 + 3d) + (a_1 + 6d) + \dots + (a_1 + 15d)$$

$$= 6a_1 + (3 + 6 + 9 + 12 + 15)d$$

$$\therefore 6a_1 + 45d = 114 \quad \text{(given)}$$

$$\Rightarrow 2a_1 + 15d = 38 \quad \dots(i)$$

Now, $a_1 + a_6 + a_{11} + a_{16}$

$$= a_1 + (a_1 + 5d) + (a_1 + 10d) + (a_1 + 15d)$$

$$= 4a_1 + 30d = 2(2a_1 + 15d)$$

$$= 2 \times 38 = 76 \quad \text{[from Eq. (i)]}$$

2. Let t_n be the n th term of given AP. Then, we have $t_{19} = 0$
- $$\Rightarrow a + (19-1)d = 0 \quad [\because t_n = a + (n-1)d]$$
- $$\Rightarrow a + 18d = 0 \quad \dots(i)$$

Now, $\frac{t_{49}}{t_{29}} = \frac{a + 48d}{a + 28d}$

$$= \frac{-18d + 48d}{-18d + 28d} \quad \text{[using Eq. (i)]}$$

$$= \frac{30d}{10d} = 3:1$$

3. We have,
- $$225a^2 + 9b^2 + 25c^2 - 75ac - 45ab - 15bc = 0$$
- $$\Rightarrow (15a)^2 + (3b)^2 + (5c)^2 - (15a)(5c) - (15a)(3b) - (3b)(5c) = 0$$
- $$\Rightarrow \frac{1}{2} [(15a - 3b)^2 + (3b - 5c)^2 + (5c - 15a)^2] = 0$$
- $$\Rightarrow 15a = 3b, 3b = 5c \text{ and } 5c = 15a$$
- $$\therefore 15a = 3b = 5c \Rightarrow \frac{a}{1} = \frac{b}{5} = \frac{c}{3} = \lambda \quad \text{(say)}$$
- $$\Rightarrow a = \lambda, b = 5\lambda, c = 3\lambda$$
- $\therefore b, c, a$ are in AP.

4. Let $T_m = a + (m-1)d = \frac{1}{n} \quad \dots(i)$
- and $T_n = a + (n-1)d = \frac{1}{m} \quad \dots(ii)$

On subtracting Eq. (ii) from Eq. (i), we get

$$(m-n)d = \frac{1}{n} - \frac{1}{m} = \frac{m-n}{mn}$$

$$\Rightarrow d = \frac{1}{mn}$$

Again, $T_{mn} = a + (mn-1)d$

$$= a + (mn-n+n-1)d$$

$$= a + (n-1)d + (mn-n)d$$

$$= T_n + n(m-1)\frac{1}{mn} = \frac{1}{m} + \frac{(m-1)}{m} = 1$$

5. Since, a_1, a_2, \dots, a_n are in an AP.

$$\therefore (a_2 - a_1) = (a_3 - a_2) = \dots = (a_n - a_{n-1}) = d$$

Thus, $\frac{1}{\sqrt{a_1} + \sqrt{a_2}} + \frac{1}{\sqrt{a_2} + \sqrt{a_3}} + \dots + \frac{1}{\sqrt{a_{n-1}} + \sqrt{a_n}}$

$$= \left(\frac{\sqrt{a_2} - \sqrt{a_1}}{d} \right) + \left(\frac{\sqrt{a_3} - \sqrt{a_2}}{d} \right) + \dots + \left(\frac{\sqrt{a_n} - \sqrt{a_{n-1}}}{d} \right)$$

$$= \frac{1}{d} (\sqrt{a_n} - \sqrt{a_1}) = \frac{1}{d} \frac{(a_n - a_1)}{\sqrt{a_n} + \sqrt{a_1}} = \frac{(n-1)}{\sqrt{a_n} + \sqrt{a_1}}$$

6. Since, n_1, n_2, \dots, n_p are p positive integers, whose sum is even and we know that, sum of any two odd integers is even.

\therefore Number of odd integers must be even.

Hence, it is a false statement.

7. Given that, $AP(a; d)$ denote the set of all the terms of an infinite arithmetic progression with first term ' a ' and common difference $d > 0$.

Now, let m^{th} term of first progression

$$AP(1; 3) = 1 + (m-1)3 = 3m - 2 \quad \dots(i)$$

and n^{th} term of progression

$$AP(2; 5) = 2 + (n-1)5 = 5n - 3 \quad \dots(ii)$$

and r^{th} term of third progression $AP(3; 7)$

$$= 3 + (r-1)7 = 7r - 4 \quad \dots(iii)$$

are equal. Then

$$3m - 2 = 5n - 3 = 7r - 4$$

Now, for $AP(1; 3) \cap AP(2; 5) \cap AP(3; 7)$, the common terms of first and second progressions, $m = \frac{5n-1}{3}$

$\Rightarrow n = 2, 5, 11, \dots$ and the common terms of second and the third progressions, $r = \frac{5n+1}{7} \Rightarrow n = 4, 11, \dots$

Now, the first common term of first, second and third progressions (when $n = 11$), so $a = 2 + (11-1)5 = 52$

and $d = \text{LCM}(3, 5, 7) = 105$

So, $AP(1; 3) \cap AP(2; 5) \cap AP(3; 7) = AP(52; 105)$

So, $a = 52$ and $d = 105 \Rightarrow a + d = 157.00$

8. Let the sides are $a-d, a$ and $a+d$. Then,

$$a(a-d) = 48$$

$$\text{and } a^2 - 2ad + d^2 + a^2 = a^2 + 2ad + d^2$$

$$\Rightarrow a^2 = 4ad$$

$$\Rightarrow a = 4d$$

$$\text{Thus, } a = 8, d = 2$$

$$\text{Hence, } a - d = 6$$

Topic 2 Sum of n Terms of an AP

1. Let the common difference of given AP is ' d '.

Since, $a_1 + a_7 + a_{16} = 40$
 $\therefore a_1 + a_1 + 6d + a_1 + 15d = 40$ [$\because a_n = a_1 + (n-1)d$]
 $\Rightarrow 3a_1 + 21d = 40$... (i)

Now, sum of first 15 terms is given by

$$S_{15} = \frac{15}{2} [2a_1 + (15-1)d]$$

$$= \frac{15}{2} [2a_1 + 14d] = 15 [a_1 + 7d]$$

From Eq. (i), we have

$$a_1 + 7d = \frac{40}{3}$$

So, $S_{15} = 15 \times \frac{40}{3}$
 $= 5 \times 40 = 200$

2. Given S_n denote the sum of the first n terms of an AP.

Let first term and common difference of the AP be ' a ' and ' d ', respectively.

$\therefore S_4 = 2[2a + 3d] = 16$ (given)

$$\left[\because S_n = \frac{n}{2} [2a + (n-1)d] \right]$$

$\Rightarrow 2a + 3d = 8$... (i)

and $S_6 = 3[2a + 5d] = -48$ [given]

$\Rightarrow 2a + 5d = -16$... (ii)

On subtracting Eq. (i) from Eq. (ii), we get

$$2d = -24$$

$$\Rightarrow d = -12$$

So, $2a = 44$ [put $d = -12$ in Eq. (i)]

Now, $S_{10} = 5[2a + 9d]$
 $= 5[44 + 9(-12)] = 5[44 - 108]$
 $= 5 \times (-64) = -320$

3. Given series is

$$\left[-\frac{1}{3} \right] + \left[-\frac{1}{3} - \frac{1}{100} \right] + \left[-\frac{1}{3} - \frac{2}{100} \right] + \dots + \left[-\frac{1}{3} - \frac{99}{100} \right]$$

[where, $[x]$ denotes the greatest integer $\leq x$]

Now,

$$\left[-\frac{1}{3} \right], \left[-\frac{1}{3} - \frac{1}{100} \right], \left[-\frac{1}{3} - \frac{2}{100} \right], \dots + \left[-\frac{1}{3} - \frac{66}{100} \right]$$

all the term have value -1

and $\left[-\frac{1}{3} - \frac{67}{100} \right], \left[-\frac{1}{3} - \frac{68}{100} \right], \dots, \left[-\frac{1}{3} - \frac{99}{100} \right]$ all the term have value -2 .

So, $\left[-\frac{1}{3} \right] + \left[-\frac{1}{3} - \frac{1}{100} \right] + \left[-\frac{1}{3} - \frac{2}{100} \right] + \dots + \left[-\frac{1}{3} - \frac{66}{100} \right]$

$= -1 - 1 - 1 - 1 \dots 67$ times.

$= (-1) \times 67 = -67$

and $\left[-\frac{1}{3} - \frac{67}{100} \right] + \left[-\frac{1}{3} - \frac{68}{100} \right] + \dots + \left[-\frac{1}{3} - \frac{99}{100} \right]$

$= -2 - 2 - 2 - 2 \dots 33$ times

$= (-2) \times 33 = -66$

$$\therefore \left[-\frac{1}{3} \right] + \left[-\frac{1}{3} - \frac{1}{100} \right] + \left[-\frac{1}{3} - \frac{2}{100} \right] + \dots + \left[-\frac{1}{3} - \frac{99}{100} \right]$$

$= (-67) + (-66) = -133$.

Alternate Solution

$\because [-x] = -[x] - 1$, if $x \notin \text{Integer}$,

and $[x] + \left[x + \frac{1}{n} \right] + \left[x + \frac{2}{n} \right] + \dots + \left[x + \frac{n-1}{n} \right] = [nx]$,

$n \in N$.

So given series

$$\left[-\frac{1}{3} \right] + \left[-\frac{1}{3} - \frac{1}{100} \right] + \left[-\frac{1}{3} - \frac{2}{100} \right] + \dots + \left[-\frac{1}{3} - \frac{99}{100} \right]$$

$$= \left(-\left[\frac{1}{3} \right] - 1 \right) + \left(-\left[\frac{1}{3} + \frac{1}{100} \right] - 1 \right)$$

$$+ \left(-\left[\frac{1}{3} + \frac{2}{100} \right] - 1 \right) + \dots + \left(-\left[\frac{1}{3} + \frac{99}{100} \right] - 1 \right)$$

$$= (-1) \times 100 - \left[\frac{1}{3} \times 100 \right] = -100 - 33 = -133$$

4. Let first three terms of an AP as $a - d, a, a + d$.

So, $3a = 33 \Rightarrow a = 11$

[given sum of three terms = 33

and product of terms = 1155]

$\Rightarrow (11 - d)11(11 + d) = 1155$ [given]

$\Rightarrow 11^2 - d^2 = 105$

$\Rightarrow d^2 = 121 - 105 = 16$

$\Rightarrow d = \pm 4$

So the first three terms of the AP are either 7, 11, 15 or 15, 11, 7.

So, the 11th term is either $7 + (10 \times 4) = 47$

or $15 + (10 \times (-4)) = -25$.

5. **Key Idea** Use the formula of sum of first n terms of AP, i.e

$$S_n = \frac{n}{2} [2a + (n-1)d]$$

Given AP, is

a_1, a_2, a_3, \dots having sum of first n -terms

$$= \frac{n}{2} [2a_1 + (n-1)d]$$

[where, d is the common difference of AP]

$$= 50n + \frac{n(n-7)}{2} A \quad (\text{given})$$

$\Rightarrow \frac{1}{2} [2a_1 + (n-1)d] = 50 + \frac{n-7}{2} A$

$\Rightarrow \frac{1}{2} [2a_1 + nd - d] = \left(50 - \frac{7}{2} A \right) + \frac{n}{2} A$

$\Rightarrow \left(a_1 - \frac{d}{2} \right) + \frac{nd}{2} = \left(50 - \frac{7}{2} A \right) + \frac{n}{2} A$

On comparing corresponding term, we get

$$d = A \text{ and } a_1 - \frac{d}{2} = 50 - \frac{7}{2} A$$

60 Sequences and Series

$$\Rightarrow a_1 - \frac{A}{2} = 50 - \frac{7}{2}A \quad [\because d = A]$$

$$\Rightarrow a_1 = 50 - 3A$$

$$\begin{aligned} \text{So } a_{50} &= a_1 + 49d \\ &= (50 - 3A) + 49A \\ &= 50 + 46A \end{aligned} \quad [\because d = A]$$

Therefore, $(d, a_{50}) = (A, 50 + 46A)$

6. Clearly, the two digit number which leaves remainder 2 when divided by 7 is of the form $N = 7k + 2$ [by Division Algorithm]

$$\begin{aligned} \text{For, } k &= 2, N = 16 \\ k &= 3, N = 23 \\ &\vdots \\ k &= 13, N = 93 \end{aligned}$$

\therefore 12 such numbers are possible and these numbers forms an AP.

$$\text{Now, } S = \frac{12}{2} [16 + 93] = 654$$

$$\left(\because S_n = \frac{n}{2} (a + l) \right)$$

Similarly, the two digit number which leaves remainder 5 when divided by 7 is of the form $N = 7k + 5$

$$\begin{aligned} \text{For } k &= 1, N = 12 \\ k &= 2, N = 19 \\ &\vdots \\ k &= 13, N = 96 \end{aligned}$$

\therefore 13 such numbers are possible and these numbers also forms an AP.

$$\text{Now, } S' = \frac{13}{2} [12 + 96] = 702$$

$$\left(\because S_n = \frac{n}{2} (a + l) \right)$$

$$\text{Total sum} = S + S' = 654 + 702 = 1356$$

7. We have, $S = a_1 + a_2 + \dots + a_{30}$
 $= 15[2a_1 + 29d]$... (i)
 (where d is the common difference)

$$\left[\because S_n = \frac{n}{2} [2a + (n-1)d] \right]$$

$$\begin{aligned} \text{and } T &= a_1 + a_3 + \dots + a_{29} \\ &= \frac{15}{2} [2a_1 + 14 \times 2d] \end{aligned}$$

(\because common difference is $2d$)

$$\Rightarrow 2T = 15[2a_1 + 28d] \quad \dots \text{(ii)}$$

From Eqs. (i) and (ii), we get

$$S - 2T = 15d = 75 \quad [\because S - 2T = 75]$$

$$\Rightarrow d = 5$$

$$\begin{aligned} \text{Now, } a_{10} &= a_5 + 5d \\ &= 27 + 25 = 52 \end{aligned}$$

8. If $\log b_1, \log b_2, \dots, \log b_{101}$ are in AP, with common difference $\log_e 2$, then b_1, b_2, \dots, b_{101} are in GP, with common ratio 2.

$$\therefore b_1 = 2^0 b_1, b_2 = 2^1 b_1, b_3 = 2^2 b_1, \dots, b_{101} = 2^{100} b_1 \quad \dots \text{(i)}$$

Also, a_1, a_2, \dots, a_{101} are in AP.

$$\text{Given, } a_1 = b_1 \text{ and } a_{51} = b_{51}$$

$$\Rightarrow a_1 + 50D = 2^{50} b_1$$

$$\Rightarrow a_1 + 50D = 2^{50} a_1 \quad [\because a_1 = b_1] \dots \text{(ii)}$$

$$\text{Now, } t = b_1 + b_2 + \dots + b_{51}$$

$$\Rightarrow t = b_1 \frac{(2^{51} - 1)}{2 - 1} \quad \dots \text{(iii)}$$

and

$$\begin{aligned} s &= a_1 + a_2 + \dots + a_{51} \\ &= \frac{51}{2} (2a_1 + 50D) \end{aligned} \quad \dots \text{(iv)}$$

$$\therefore t = a_1 (2^{51} - 1) \quad [\because a_1 = b_1]$$

$$\text{or } t = 2^{51} a_1 - a_1 < 2^{51} a_1 \quad \dots \text{(v)}$$

$$\text{and } s = \frac{51}{2} [a_1 + (a_1 + 50D)] \quad [\text{from Eq. (ii)}]$$

$$= \frac{51}{2} [a_1 + 2^{50} a_1]$$

$$= \frac{51}{2} a_1 + \frac{51}{2} 2^{50} a_1$$

$$\therefore s > 2^{51} a_1 \quad \dots \text{(vi)}$$

From Eqs. (v) and (vi), we get $s > t$

$$\text{Also, } a_{101} = a_1 + 100D \text{ and } b_{101} = 2^{100} b_1$$

$$\therefore a_{101} = a_1 + 100 \left(\frac{2^{50} a_1 - a_1}{50} \right) \text{ and } b_{101} = 2^{100} a_1$$

$$\Rightarrow a_{101} = a_1 + 2^{51} a_1 - 2a_1 = 2^{51} a_1 - a_1$$

$$\Rightarrow a_{101} < 2^{51} a_1 \text{ and } b_{101} > 2^{51} a_1$$

$$\Rightarrow b_{101} > a_{101}$$

9. Let $S_n = cn^2$

$$S_{n-1} = c(n-1)^2 = cn^2 + c - 2cn$$

$$\therefore T_n = 2cn - c \quad [\because T_n = S_n - S_{n-1}]$$

$$T_n^2 = (2cn - c)^2 = 4c^2 n^2 + c^2 - 4c^2 n$$

$$\therefore \text{Sum} = \sum T_n^2 = \frac{4c^2 \cdot n(n+1)(2n+1)}{6} + nc^2 - 2c^2 n(n+1)$$

$$= \frac{2c^2 n(n+1)(2n+1) + 3nc^2 - 6c^2 n(n+1)}{3}$$

$$= \frac{nc^2(4n^2 + 6n + 2 + 3 - 6n - 6)}{3} = \frac{nc^2(4n^2 - 1)}{3}$$

10. According to given condition,

$$S_{2n} = S'_n$$

$$\Rightarrow \frac{2n}{2} [2 \times 2 + (2n-1) \times 3] = \frac{n}{2} [2 \times 57 + (n-1) \times 2]$$

$$\Rightarrow (4 + 6n - 3) = \frac{1}{2} (114 + 2n - 2)$$

$$\Rightarrow 6n + 1 = 57 + n - 1 \Rightarrow 5n = 55$$

$$\therefore n = 11$$

11. **PLAN** Convert it into differences and use sum of n terms of an AP,

$$\text{i.e. } S_n = \frac{n}{2} [2a + (n-1)d]$$

$$\text{Now, } S_n = \sum_{k=1}^{4n} (-1)^{\frac{k(k+1)}{2}} \cdot k^2$$

$$\begin{aligned}
 &= -(1)^2 - 2^2 + 3^2 + 4^2 - 5^2 - 6^2 + 7^2 + 8^2 + \dots \\
 &= (3^2 - 1^2) + (4^2 - 2^2) + (7^2 - 5^2) + (8^2 - 6^2) + \dots \\
 &= 2\left\{ \underbrace{(4 + 6 + 12 + \dots)}_{n \text{ terms}} + \underbrace{(6 + 14 + 22 + \dots)}_{n \text{ terms}} \right\} \\
 &= 2 \left[\frac{n}{2} \{2 \times 4 + (n-1)8\} + \frac{n}{2} \{2 \times 6 + (n-1)8\} \right] \\
 &= 2 [n(4 + 4n - 4) + n(6 + 4n - 4)] \\
 &= 2 [4n^2 + 4n^2 + 2n] = 4n(4n + 1)
 \end{aligned}$$

Here, $1056 = 32 \times 33$, $1088 = 32 \times 34$,

$$1120 = 32 \times 35, 1332 = 36 \times 37$$

1056 and 1332 are possible answers.

12. Here, $V_r = \frac{r}{2} [2r + (r-1)(2r-1)] = \frac{1}{2} (2r^3 - r^2 + r)$

$$\begin{aligned}
 \therefore \Sigma V_r &= \frac{1}{2} [2 \Sigma r^3 - \Sigma r^2 + \Sigma r] \\
 &= \frac{1}{2} \left[2 \left\{ \frac{n(n+1)}{2} \right\}^2 - \frac{n(n+1)(2n+1)}{6} + \frac{n(n+1)}{2} \right] \\
 \Rightarrow &= \frac{n(n+1)}{12} [3n(n+1) - (2n+1) + 3] \\
 &= \frac{1}{12} n(n+1)(3n^2 + n + 2)
 \end{aligned}$$

13. $V_{r+1} - V_r = (r+1)^3 - r^3 - \frac{1}{2} [(r+1)^2 - r^2] + \frac{1}{2} = 3r^2 + 2r - 1$

$$\therefore T_r = 3r^2 + 2r - 1 = (r+1)(3r-1)$$

which is a composite number.

14. Since, $T_r = 3r^2 + 2r - 1$

and $T_{r+1} = 3(r+1)^2 + 2(r+1) - 1$

$$\therefore Q_r = T_{r+1} - T_r = 3[2r+1] + 2 [1]$$

$$\Rightarrow Q_r = 6r + 5$$

$$\Rightarrow Q_{r+1} = 6(r+1) + 5$$

$$\text{Common difference} = Q_{r+1} - Q_r = 6$$

15. Given, $p + q = 2$, $pq = A$

and $r + s = 18$, $rs = B$

and it is given that p, q, r, s are in an AP.

Therefore, let $p = a - 3d$, $q = a - d$, $r = a + d$

and $s = a + 3d$

Since, $p < q < r < s$

We have, $d > 0$

Now, $2 = p + q = a - 3d + a - d = 2a - 4d$

$$\Rightarrow a - 2d = 1 \quad \dots(i)$$

Again, $18 = r + s = a + d + a + 3d$

$$18 = 2a + 4d$$

$$\Rightarrow 9 = a + 2d \quad \dots(ii)$$

On subtracting Eq. (i) from Eq. (ii), we get

$$8 = 4d \Rightarrow d = 2$$

On putting in Eq. (ii), we get $a = 5$

$$\therefore p = a - 3d = 5 - 6 = -1$$

$$q = a - d = 5 - 2 = 3$$

$$r = a + d = 5 + 2 = 7$$

and $s = a + 3d = 5 + 6 = 11$

Therefore, $A = pq = -3$ and $B = rs = 77$

16. Here, $1^2 + 2 \cdot 2^2 + 3^2 + 2 \cdot 4^2 + 5^2 + \dots$ upto n terms

$$= \frac{n(n+1)^2}{2} \quad [\text{when } n \text{ is even}] \dots(i)$$

When n is odd, $1^2 + 2 \cdot 2^2 + 3^2 + 2 \cdot 4^2 + 5^2 + \dots + n^2$

$$= \{1^2 + 2 \cdot 2^2 + 3^2 + 2 \cdot 4^2 + \dots + 2(n-1)^2\} + n^2$$

$$= \left\{ \frac{(n-1)(n)^2}{2} \right\} + n^2 \quad [\text{from Eq. (i)}]$$

$$= n^2 \left(\frac{n-1}{2} + 1 \right) = n^2 \frac{(n+1)}{2}$$

$\therefore 1^2 + 2 \cdot 2^2 + 3^2 + 2 \cdot 4^2 + \dots$ upto n terms, when n is odd

$$= \frac{n^2(n+1)}{2}$$

17. Integers divisible by 2 are $\{2, 4, 6, 8, 10, \dots, 100\}$.

Integers divisible by 5 are $\{5, 10, 15, \dots, 100\}$.

Thus, sum of integers divisible by 2

$$= \frac{50}{2} (2 + 100) = 50 \times 51 = 2550$$

Sum of integers divisible by 5

$$= \frac{20}{2} (5 + 100) = 10 \times 105 = 1050$$

Sum of integers divisible by 10

$$= \frac{10}{2} (10 + 100) = 5 \times 110 = 550$$

\therefore Sum of integers from 1 to 100 divisible by 2 or 5

$$= 2550 + 1050 - 550$$

$$= 2550 + 500 = 3050$$

18. Let four consecutive terms of the AP are $a - 3d, a - d, a + d, a + 3d$, which are integers.

Again, required product

$$P = (a - 3d)(a - d)(a + d)(a + 3d) + (2d)^4 \quad [\text{by given condition}]$$

$$= (a^2 - 9d^2)(a^2 - d^2) + 16d^4$$

$$= a^4 - 10a^2d^2 + 9d^4 + 16d^4 = (a^2 - 5d^2)^2$$

Now, $a^2 - 5d^2 = a^2 - 9d^2 + 4d^2$

$$= (a - 3d)(a + 3d) + (2d)^2$$

$$= I \cdot I + I^2 \quad [\text{given}]$$

$$= I^2 + I^2 = I^2$$

$$= I \quad [\text{where, } I \text{ is any integer}]$$

Therefore, $P = (I^2)^2 = \text{Integer}$

19. Since, x_1, x_2, x_3 are in an AP. Let $x_1 = a - d, x_2 = a$ and $x_3 = a + d$ and x_1, x_2, x_3 be the roots of $x^3 - x^2 + \beta x + \gamma = 0$

$$\therefore \Sigma \alpha = a - d + a + a + d = 1$$

62 Sequences and Series

$$\Rightarrow a = 1/3 \quad \dots(i)$$

$$\Sigma\alpha\beta = (a-d)a + a(a+d) + (a-d)(a+d) = \beta \quad \dots(ii)$$

$$\text{and } \alpha\beta\gamma = (a-d)a(a+d) = -\gamma \quad \dots(iii)$$

From Eq. (i),

$$3a = 1 \Rightarrow a = 1/3$$

From Eq. (ii), $3a^2 - d^2 = \beta$

$$\Rightarrow 3(1/3)^2 - d^2 = \beta \quad [\text{from Eq. (i)}]$$

$$\Rightarrow 1/3 - \beta = d^2$$

NOTE In this equation, we have two variables β and γ but we have only one equation. So, at first sight it looks that this equation cannot solve but we know that $d^2 \geq 0, \forall d \in \mathbb{R}$, then β can be solved. This trick is frequently asked in IIT examples.

$$\Rightarrow \frac{1}{3} - \beta \geq 0 \quad [\because d^2 \geq 0]$$

$$\Rightarrow \beta \leq \frac{1}{3} \Rightarrow \beta \in [-\infty, 1/3]$$

From Eq. (iii), $a(a^2 - d^2) = -\gamma$

$$\Rightarrow \frac{1}{3} \left(\frac{1}{9} - d^2 \right) = -\gamma \Rightarrow \frac{1}{27} - \frac{1}{3}d^2 = -\gamma$$

$$\Rightarrow \gamma + \frac{1}{27} = \frac{1}{3}d^2$$

$$\Rightarrow \gamma + \frac{1}{27} \geq 0$$

$$\Rightarrow \gamma \geq -1/27$$

$$\Rightarrow \gamma \in \left[-\frac{1}{27}, \infty \right)$$

Hence, $\beta \in (-\infty, 1/3]$ and $\gamma \in [-1/27, \infty)$

20. Since, angles of polygon are in an AP.

\therefore Sum of all angles

$$= (n-2) \times 180^\circ = \frac{n}{2} \{2(120^\circ) + (n-1)5^\circ\}$$

$$\Rightarrow 5n^2 - 125n + 720 = 0 \Rightarrow n^2 - 25n + 144 = 0$$

$$\Rightarrow (n-9)(n-16) = 0 \Rightarrow n = 9, 16$$

If $n=9$, then largest angle = $a + 8d = 160^\circ$

Again, if $n=16$, the n largest angle

$$= a + 15d = 120^\circ + 75 = 195^\circ$$

which is not possible.

[since, any angle of polygon cannot be $> 180^\circ$]

Hence, $n=9$ [neglecting $n=16$]

21. Given, $\frac{S_7}{S_{11}} = \frac{6}{11}$ and $130 < t_7 < 140$

$$\Rightarrow \frac{\frac{7}{2}[2a+6d]}{\frac{11}{2}[2a+10d]} = \frac{6}{11} \Rightarrow \frac{7(2a+6d)}{(2a+10d)} = 6$$

$$\Rightarrow a = 9d \quad \dots(i)$$

Also, $130 < t_7 < 140$

$$\Rightarrow 130 < a + 6d < 140$$

$$\Rightarrow 130 < 9d + 6d < 140 \quad [\text{from Eq. (i)}]$$

$$\Rightarrow 130 < 15d < 140$$

$$\Rightarrow \frac{26}{3} < d < \frac{28}{3} \quad [\text{since, } d \text{ is a natural number}]$$

$$\therefore d = 9$$

22. Let number of removed cards be k and $(k+1)$.

$$\therefore \frac{n(n+1)}{2} - k - (k+1) = 1224$$

$$\Rightarrow n^2 + n - 4k = 2450 \Rightarrow n^2 + n - 2450 = 4k$$

$$\Rightarrow (n+50)(n-49) = 4k$$

$$\therefore n > 49$$

$$\text{Let } n = 50$$

$$\therefore 100 = 4k \Rightarrow k = 25$$

$$\text{Now } k - 20 = 5$$

23. Given, $a_1 = 3, m = 5n$ and a_1, a_2, \dots , is an AP.

$$\therefore \frac{S_m}{S_n} = \frac{S_{5n}}{S_n} \text{ is independent of } n.$$

$$= \frac{\frac{5n}{2} [2 \times 3 + (5n-1)d]}{\frac{n}{2} [2 \times 3 + (n-1)d]} = \frac{5 \{(6-d) + 5n\}}{(6-d) + n},$$

independent of n

$$\text{If } 6-d=0 \Rightarrow d=6$$

$$\therefore a_2 = a_1 + d = 3 + 6 = 9$$

or If $d=0$, then $\frac{S_m}{S_n}$ is independent of n .

$$\therefore a_2 = 9$$

24. $a_k = 2a_{k-1} - a_{k-2}$

$\Rightarrow a_1, a_2, \dots, a_{11}$ are in an AP.

$$\therefore \frac{a_1^2 + a_2^2 + \dots + a_{11}^2}{11} = \frac{11a^2 + 35 \times 11d^2 + 10ad}{11} = 90$$

$$\Rightarrow 225 + 35d^2 + 150d = 90$$

$$\Rightarrow 35d^2 + 150d + 135 = 0$$

$$\Rightarrow d = -3, -\frac{9}{7}$$

$$\text{Given, } a_2 < \frac{27}{2}$$

$$\therefore d = -3 \text{ and } d \neq -\frac{9}{7}$$

$$\Rightarrow \frac{a_1 + a_2 + \dots + a_{11}}{11} = \frac{11}{2} [30 - 10 \times 3] = 0$$

Topic 3 Geometric Progression (GP)

1. **Key Idea** Use n^{th} term of AP i.e., $a_n = a + (n-1)d$, If a, A, b are in AP, then $2A = a + b$ and n^{th} term of G.P. i.e., $a_n = ar^{n-1}$.

It is given that, the terms a, b, c are in GP with common ratio r , where $a \neq 0$ and $0 < r \leq \frac{1}{2}$.

So, let, $b = ar$ and $c = ar^2$

Now, the terms $3a, 7b$ and $15c$ are the first three terms of an AP, then

$$\begin{aligned}
& 2(7b) = 3a + 15c \\
\Rightarrow & 14ar = 3a + 15ar^2 \quad [\text{as } b = ar, c = ar^2] \\
\Rightarrow & 14r = 3 + 15r^2 \quad [\text{as } a \neq 0] \\
\Rightarrow & 15r^2 - 14r + 3 = 0 \\
\Rightarrow & 15r^2 - 5r - 9r + 3 = 0 \\
\Rightarrow & 5r(3r - 1) - 3(3r - 1) = 0 \\
\Rightarrow & (3r - 1)(5r - 3) = 0 \\
\Rightarrow & r = \frac{1}{3} \text{ or } \frac{3}{5}
\end{aligned}$$

$$\text{as, } r \in \left(0, \frac{1}{2}\right] \text{ so } r = \frac{1}{3}$$

Now, the common difference of AP = $7b - 3a$

$$= 7ar - 3a = a\left(\frac{7}{3} - 3\right) = -\frac{2a}{3}$$

$$\text{So, 4}^{\text{th}} \text{ term of AP} = 3a + 3\left(\frac{-2a}{3}\right) = a$$

2. Given, three distinct numbers a, b and c are in GP.

$$\therefore b^2 = ac \quad \dots(i)$$

and the given quadratic equations

$$ax^2 + 2bx + c = 0 \quad \dots(ii)$$

$$dx^2 + 2ex + f = 0 \quad \dots(iii)$$

For quadratic Eq. (ii),

the discriminant $D = (2b)^2 - 4ac$

$$= 4(b^2 - ac) = 0 \quad [\text{from Eq. (i)}]$$

\Rightarrow Quadratic Eq. (ii) have equal roots, and it is equal to $x = -\frac{b}{a}$, and it is given that quadratic Eqs. (ii) and (iii)

have a common root, so

$$d\left(-\frac{b}{a}\right)^2 + 2e\left(-\frac{b}{a}\right) + f = 0$$

$$\Rightarrow db^2 - 2eba + a^2f = 0$$

$$\Rightarrow d(ac) - 2eab + a^2f = 0 \quad [\because b^2 = ac]$$

$$\Rightarrow dc - 2eb + af = 0 \quad [\because a \neq 0]$$

$$\Rightarrow 2eb = dc + af$$

$$\Rightarrow 2\frac{e}{b} = \frac{dc}{b^2} + \frac{af}{b^2}$$

[dividing each term by b^2]

$$\Rightarrow 2\left(\frac{e}{b}\right) = \frac{d}{a} + \frac{f}{c} \quad [\because b^2 = ac]$$

So, $\frac{d}{a}, \frac{e}{b}, \frac{f}{c}$ are in AP.

Alternate Solution

Given, three distinct numbers a, b and c are in GP. Let $a = a, b = ar, c = ar^2$ are in GP, which satisfies

$$ax^2 + 2bx + c = 0$$

$$\therefore ax^2 + 2(ar)x + ar^2 = 0$$

$$\Rightarrow x^2 + 2rx + r^2 = 0 \quad [\because a \neq 0]$$

$$\Rightarrow (x + r)^2 = 0 \Rightarrow x = -r.$$

According to the question, $ax^2 + 2bx + c = 0$ and $dx^2 + 2ex + f = 0$ have a common root.

So, $x = -r$ satisfies $dx^2 + 2ex + f = 0$

$$\therefore d(-r)^2 + 2e(-r) + f = 0$$

$$\Rightarrow dr^2 - 2er + f = 0$$

$$\Rightarrow d\left(\frac{c}{a}\right) - 2e\left(\frac{c}{b}\right) + f = 0$$

$$\Rightarrow \frac{d}{a} - \frac{2e}{b} + \frac{f}{c} = 0$$

$$\Rightarrow \frac{d}{a} + \frac{f}{c} = \frac{2e}{b} \quad [\because c \neq 0]$$

3. Let the three consecutive terms of a GP are $\frac{a}{r}, a$ and ar .

Now, according to the question, we have

$$\frac{a}{r} \cdot a \cdot ar = 512$$

$$\Rightarrow a^3 = 512$$

$$\Rightarrow a = 8 \quad \dots(i)$$

Also, after adding 4 to first two terms, we get

$$\frac{8}{r} + 4, 8 + 4, 8r$$
 are in AP

$$\Rightarrow 2(12) = \frac{8}{r} + 4 + 8r$$

$$\Rightarrow 24 = \frac{8}{r} + 8r + 4 \Rightarrow 20 = 4\left(\frac{2}{r} + 2r\right)$$

$$\Rightarrow 5 = \frac{2}{r} + 2r \Rightarrow 2r^2 - 5r + 2 = 0$$

$$\Rightarrow 2r^2 - 4r - r + 2 = 0$$

$$\Rightarrow 2r(r - 2) - 1(r - 2) = 0$$

$$\Rightarrow (r - 2)(2r - 1) = 0$$

$$\Rightarrow r = 2, \frac{1}{2}$$

Thus, the terms are either 16, 8, 4 or 4, 8, 16. Hence, required sum = 28.

4. Let r be the common ratio of given GP, then we have the following sequence $a_1, a_2 = a_1r, a_3 = a_1r^2, \dots, a_{10} = a_1r^9$

$$\text{Now, } a_3 = 25a_1$$

$$\Rightarrow a_1r^2 = 25a_1$$

$$\Rightarrow r^2 = 25$$

$$\text{Consider, } \frac{a_9}{a_5} = \frac{a_1r^8}{a_1r^4} = r^4 = (25)^2 = 5^4$$

5. Let A be the 1st term of AP and d be the common difference.

$$\therefore 7\text{th term} = a = A + 6d$$

$$[\because n\text{th term} = A + (n - 1)d]$$

$$11\text{th term} = b = A + 10d$$

$$13\text{th term} = c = A + 12d$$

$\therefore a, b, c$ are also in GP

$$\therefore b^2 = ac$$

$$\Rightarrow (A + 10d)^2 = (A + 6d)(A + 12d)$$

$$\Rightarrow A^2 + 20Ad + 100d^2 = A^2 + 18Ad + 72d^2$$

$$\Rightarrow 2Ad + 28d^2 = 0$$

$$\Rightarrow 2d(A + 14d) = 0$$

$$\Rightarrow d = 0 \text{ or } A + 14d = 0$$

But $d \neq 0$ [\because the series is non constant AP]

$$\Rightarrow A = -14d$$

64 Sequences and Series

$$\begin{aligned} \therefore a &= A + 6d = -14d + 6d = -8d \\ \text{and } c &= A + 12d = -14d + 12d = -2d \\ \Rightarrow \frac{a}{c} &= \frac{-8d}{-2d} = 4 \end{aligned}$$

6. Let $b = ar$ and $c = ar^2$, where r is the common ratio.

$$\begin{aligned} \text{Then, } a + b + c &= xb \\ \Rightarrow a + ar + ar^2 &= xar \\ \Rightarrow 1 + r + r^2 &= xr \quad \dots \text{(i) } [\because a \neq 0] \\ \Rightarrow x &= \frac{1 + r + r^2}{r} = 1 + r + \frac{1}{r} \end{aligned}$$

We know that, $r + \frac{1}{r} \geq 2$ (for $r > 0$)

and $r + \frac{1}{r} \leq -2$ (for $r < 0$) [using AM \geq GM]

$$\therefore 1 + r + \frac{1}{r} \geq 3$$

$$\text{or } 1 + r + \frac{1}{r} \leq -1$$

$$\Rightarrow x \geq 3 \text{ or } x \leq -1$$

$$\Rightarrow x \in (-\infty, -1] \cup [3, \infty)$$

Hence, x cannot be 2.

Alternate Method

From Eq. (i), we have

$$1 + r + r^2 = xr \Rightarrow r^2 + (1-x)r + 1 = 0$$

For real solution of r , $D \geq 0$.

$$\Rightarrow (1-x)^2 - 4 \geq 0$$

$$\Rightarrow x^2 - 2x - 3 \geq 0$$

$$\Rightarrow (x-3)(x+1) \geq 0$$

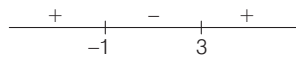

$$\Rightarrow x \in (-\infty, -1] \cup [3, \infty)$$

$\therefore x$ cannot be 2.

7. Let a be the first term and d be the common difference.

Then, we have $a + d, a + 4d, a + 8d$ in GP,

$$\text{i.e. } (a + 4d)^2 = (a + d)(a + 8d)$$

$$\Rightarrow a^2 + 16d^2 + 8ad = a^2 + 8ad + ad + 8d^2$$

$$\Rightarrow 8d^2 = ad$$

$$\Rightarrow 8d = a \quad [\because d \neq 0]$$

Now, common ratio,

$$r = \frac{a + 4d}{a + d} = \frac{8d + 4d}{8d + d} = \frac{12d}{9d} = \frac{4}{3}$$

8. Since, $(\alpha + \beta), (\alpha^2 + \beta^2), (\alpha^3 + \beta^3)$ are in GP.

$$\Rightarrow (\alpha^2 + \beta^2)^2 = (\alpha + \beta)(\alpha^3 + \beta^3)$$

$$\Rightarrow \alpha^4 + \beta^4 + 2\alpha^2\beta^2 = \alpha^4 + \beta^4 + \alpha\beta^3 + \beta\alpha^3$$

$$\Rightarrow \alpha\beta(\alpha^2 + \beta^2 - 2\alpha\beta) = 0$$

$$\Rightarrow \alpha\beta(\alpha - \beta)^2 = 0$$

$$\Rightarrow \alpha\beta = 0 \quad \text{or} \quad \alpha = \beta$$

$$\Rightarrow \frac{c}{a} = 0 \quad \text{or} \quad \Delta = 0$$

$$\Rightarrow c\Delta = 0$$

9. Since, a, b and c are in an AP.

$$\text{Let } a = A - D, b = A, c = A + D$$

$$\text{Given, } a + b + c = \frac{3}{2}$$

$$\Rightarrow (A - D) + A + (A + D) = \frac{3}{2}$$

$$\Rightarrow 3A = \frac{3}{2} \Rightarrow A = \frac{1}{2}$$

\therefore The number are $\frac{1}{2} - D, \frac{1}{2}, \frac{1}{2} + D$.

Also, $\left(\frac{1}{2} - D\right)^2, \frac{1}{4}, \left(\frac{1}{2} + D\right)^2$ are in GP.

$$\therefore \left(\frac{1}{4}\right)^2 = \left(\frac{1}{2} - D\right)^2 \left(\frac{1}{2} + D\right)^2 \Rightarrow \frac{1}{16} = \left(\frac{1}{4} - D^2\right)^2$$

$$\Rightarrow \frac{1}{4} - D^2 = \pm \frac{1}{4} \Rightarrow D^2 = \frac{1}{2}$$

$$\Rightarrow D = \pm \frac{1}{\sqrt{2}} \Rightarrow a = \frac{1}{2} \pm \frac{1}{\sqrt{2}}$$

So, out of the given values, $a = \frac{1}{2} - \frac{1}{\sqrt{2}}$ is the right choice.

$$10. \left. \begin{aligned} \alpha + \beta &= 1 \\ \alpha\beta &= p \end{aligned} \right\} \quad \text{and} \quad \left. \begin{aligned} \lambda + \delta &= 4 \\ \lambda\delta &= q \end{aligned} \right\}$$

Let r be the common ratio.

Since, α, β, γ and δ are in GP.

$$\text{Therefore, } \beta = \alpha r, \gamma = \alpha r^2$$

$$\text{and } \delta = \alpha r^3$$

$$\text{Then, } \alpha + \alpha r = 1 \Rightarrow \alpha(1 + r) = 1 \quad \dots \text{(i)}$$

$$\text{and } \alpha r^2 + \alpha r^3 = 4 \Rightarrow \alpha r^2(1 + r) = 4 \quad \dots \text{(ii)}$$

From Eqs. (i) and (ii), $r^2 = 4 \Rightarrow r = \pm 2$

$$\text{Now, } \alpha \cdot \alpha r = p \text{ and } \alpha r^2 \cdot \alpha r^3 = q$$

On putting $r = -2$, we get

$$\alpha = -1, p = -2 \text{ and } q = -32$$

Again putting $r = 2$, we get $\alpha = 1/3$ and $p = -\frac{2}{9}$

Since, q and p are integers.

Therefore, we take $p = -2$ and $q = -32$.

$$11. \text{ Here, } (a^2 + b^2 + c^2)p^2 - 2(ab + bc + cd)p + (b^2 + c^2 + d^2) \leq 0$$

$$\Rightarrow (a^2p^2 - 2abp + b^2) + (b^2p^2 - 2bcp + c^2) + (c^2p^2 - 2cdp + d^2) \leq 0$$

$$\Rightarrow (ap - b)^2 + (bp - c)^2 + (cp - d)^2 \leq 0$$

[since, sum of squares is never less than zero]

Since, each of the squares is zero.

$$\therefore (ap - b)^2 = (bp - c)^2 = (cp - d)^2 = 0$$

$$\Rightarrow p = \frac{b}{a} = \frac{c}{b} = \frac{d}{c}$$

$\therefore a, b, c, d$ are in GP.

12. Since, a, b, c are in GP.

$$\Rightarrow b^2 = ac$$

Given, $ax^2 + 2bx + c = 0$

$$\Rightarrow ax^2 + 2\sqrt{ac}x + c = 0$$

$$\Rightarrow (\sqrt{a}x + \sqrt{c})^2 = 0 \Rightarrow x = -\sqrt{\frac{c}{a}}$$

Since, $ax^2 + 2bx + c = 0$ and $dx^2 + 2ex + f = 0$ have common root.

$\therefore x = -\sqrt{\frac{c}{a}}$ must satisfy.

$$\Rightarrow dx^2 + 2ex + f = 0$$

$$\Rightarrow d \cdot \frac{c}{a} - 2e\sqrt{\frac{c}{a}} + f = 0 \Rightarrow \frac{d}{a} - \frac{2e}{\sqrt{ac}} + \frac{f}{c} = 0$$

$$\Rightarrow \frac{2e}{b} = \frac{d}{a} + \frac{f}{c} \quad [\because b^2 = ac]$$

Hence, $\frac{d}{a}, \frac{e}{b}, \frac{f}{c}$ are in an AP.

13. Here, $t_3 = 4 \Rightarrow ar^2 = 4$

$$\therefore \text{Product of first five terms} = a \cdot ar \cdot ar^2 \cdot ar^3 \cdot ar^4$$

$$= a^5 r^{10} = (ar^2)^5 = 4^5$$

14. If $a, b, c \in (2, 18)$, then

$$a + b + c = 25 \quad \dots(i)$$

Since, $2, a, b$ are in AP.

$$\Rightarrow 2a = b + 2 \quad \dots(ii)$$

and $b, c, 18$ are in GP.

$$\Rightarrow c^2 = 18b \quad \dots(iii)$$

From Eqs. (i), (ii) and (iii),

$$\frac{b+2}{2} + b + \sqrt{18b} = 25$$

$$\Rightarrow 3b + 2 + 6\sqrt{2}\sqrt{b} = 50$$

$$\Rightarrow 3b + 6\sqrt{2}\sqrt{b} - 48 = 0$$

$$\Rightarrow b + 2\sqrt{2}\sqrt{b} - 16 = 0$$

$$\Rightarrow b + 4\sqrt{2}\sqrt{b} - 2\sqrt{2}\sqrt{b} - 16 = 0$$

$$\Rightarrow \sqrt{b}(\sqrt{b} + 4\sqrt{2}) - 2\sqrt{2}(\sqrt{b} + 4\sqrt{2}) = 0$$

$$\Rightarrow (\sqrt{b} - 2\sqrt{2})(\sqrt{b} + 4\sqrt{2}) = 0$$

$$\Rightarrow b = 8, a = 5 \text{ and } c = 12$$

15. Let 27, 8, 12 be three terms of a GP.

$$\Rightarrow t_m = 27, t_n = 8 \text{ and } t_p = 12$$

$$AR^{m-1} = 27, AR^{n-1} = 8$$

$$\text{and } AR^{p-1} = 12$$

$$\therefore R = \left(\frac{27}{8}\right)^{\frac{1}{m-n}} \text{ and } R = \left(\frac{8}{12}\right)^{\frac{1}{n-p}}$$

$$\Rightarrow \left(\frac{27}{8}\right)^{\frac{1}{m-n}} = \left(\frac{2}{3}\right)^{\frac{1}{n-p}}$$

$$\Rightarrow 3^{\frac{3}{m-n}} \cdot 3^{\frac{1}{n-p}} = 2^{\frac{1}{n-p}} \cdot 2^{\frac{3}{m-n}}$$

$$\Rightarrow \frac{3^{\frac{3}{m-n} + \frac{1}{n-p}}}{2^{\frac{1}{n-p} + \frac{3}{m-n}}} = 1 \Rightarrow \frac{3}{m-n} + \frac{1}{n-p} = 0$$

$$\text{and } \frac{1}{n-p} + \frac{3}{m-n} = 0$$

$$\Rightarrow 3(n-p) = n-m$$

$$\text{and } 2n = 3p - m$$

Hence, there exists infinite GP for which 27, 8 and 12 as three of its terms.

16. Let a, d be the first term and common difference of an AP and b, r be the first term and common ratio of a GP.

$$\text{Then, } x = a + (m-1)d \text{ and } x = br^{m-1}$$

$$y = a + (n-1)d \text{ and } y = br^{n-1}$$

$$z = a + (p-1)d \text{ and } z = br^{p-1}$$

$$\text{Now, } x - y = (m-n)d, y - z = (n-p)d$$

$$\text{and } z - x = (p-m)d$$

$$\text{Again now, } x^{y-z} \cdot y^{z-x} \cdot z^{x-y}$$

$$= [br^{m-1}]^{(n-p)d} \cdot [br^{n-1}]^{(p-m)d} \cdot [br^{p-1}]^{(m-n)d}$$

$$= b^{[(n-p)+p-m+m-n]d} \cdot r^{[(m-1)(n-p)+(n-1)(p-m)+(p-1)(m-n)]d}$$

$$= b^0 \cdot r^0 = 1$$

Topic 4 Sum of n Terms and Infinite Terms of a GP

1. Given series of infinite terms, if $|x| < 1, |y| < 1$ and $x \neq y$ is

$$S = (x + y) + (x^2 + xy + y^2) + (x^3 + x^2y + xy^2 + y^3) + \dots$$

On multiplying $(x - y)$ both sides, we get

$$\Rightarrow (x - y)S = (x^2 - y^2) + (x^3 - y^3) + (x^4 - y^4) + \dots$$

$$= [x^2 + x^3 + x^4 + \dots] - [y^2 + y^3 + y^4 + \dots]$$

$$= \frac{x^2}{1-x} - \frac{y^2}{1-y} \text{ as } |x| < 1 \text{ and } |y| < 1$$

$$\Rightarrow (x - y)S = \frac{x^2(1-y) - y^2(1-x)}{(1-x)(1-y)} = \frac{(x^2 - y^2) - (x^2y - y^2x)}{(1-x)(1-y)}$$

$$\Rightarrow (x - y)S = \frac{(x - y)[(x + y) - xy]}{(1-x)(1-y)} \Rightarrow S = \frac{x + y - xy}{(1-x)(1-y)}$$

2. Let $S = \sum_{k=1}^{20} k\left(\frac{1}{2^k}\right)$

$$S = \frac{1}{2} + \frac{2}{2^2} + \frac{3}{2^3} + \frac{4}{2^4} + \dots + \frac{20}{2^{20}} \quad \dots(i)$$

On multiplying by $\left(\frac{1}{2}\right)$ both sides, we get

$$\frac{S}{2} = \frac{1}{2^2} + \frac{2}{2^3} + \frac{3}{2^4} + \dots + \frac{19}{2^{20}} + \frac{20}{2^{21}} \quad \dots(ii)$$

On subtracting Eq. (ii) from Eq. (i), we get

$$S - \frac{S}{2} = \frac{1}{2} + \frac{1}{2^2} + \frac{1}{2^3} + \dots + \frac{1}{2^{20}} - \frac{20}{2^{21}}$$

$$\Rightarrow \frac{S}{2} = \frac{1}{2} \left(1 - \frac{1}{2^{20}}\right) - \frac{20}{2^{21}}$$

$$\left[\because \text{sum of GP} = \frac{a(1-r^n)}{1-r}, r < 1 \right]$$

66 Sequences and Series

$$\frac{S}{2} = 1 - \frac{1}{2^{20}} - \frac{20}{2^{21}} = 1 - \frac{1}{2^{20}} - \frac{10}{2^{20}} = 1 - \frac{11}{2^{20}}$$

$$\Rightarrow S = 2 - \frac{11}{2^{19}}$$

3. We have, $S_n = 1 + q + q^2 + \dots + q^n$ and

$$T_n = 1 + \left(\frac{q+1}{2}\right) + \left(\frac{q+1}{2}\right)^2 + \dots + \left(\frac{q+1}{2}\right)^n$$

Also, we have

$${}^{101}C_1 + {}^{101}C_2 S_1 + {}^{101}C_3 S_2 + \dots + {}^{101}C_{101} S_{100} = \alpha T_{100}$$

$$\Rightarrow {}^{101}C_1 + {}^{101}C_2(1+q) + {}^{101}C_3(1+q+q^2) + \dots + {}^{101}C_{101}(1+q+q^2+\dots+q^{100}) = \alpha \cdot T_{100}$$

$$\Rightarrow {}^{101}C_1 + {}^{101}C_2 \frac{(1-q^2)}{1-q} + {}^{101}C_3 \left(\frac{1-q^3}{1-q}\right) + {}^{101}C_4 \left(\frac{1-q^4}{1-q}\right) + \dots + {}^{101}C_{101} \left(\frac{1-q^{101}}{1-q}\right) = \alpha \cdot T_{100}$$

[\because for a GP, $S_n = a \left(\frac{1-r^n}{1-r}\right)$, $r \neq 1$]

$$\Rightarrow \frac{1}{1-q} \{ {}^{101}C_1 + {}^{101}C_2 + \dots + {}^{101}C_{101} \} - \{ {}^{101}C_1 q + {}^{101}C_2 q^2 + \dots + {}^{101}C_{101} q^{101} \} = \alpha \cdot T_{100}$$

$$\Rightarrow \frac{1}{(1-q)} [(2^{101} - 1) - ((1+q)^{101} - 1)] = \alpha T_{100}$$

[$\because {}^n C_0 + {}^n C_1 + \dots + {}^n C_n = 2^n$]

$$\Rightarrow \frac{2^{101} - (q+1)^{101}}{1-q} = \alpha$$

$$\left[1 + \frac{q+1}{2} + \left(\frac{q+1}{2}\right)^2 + \dots + \left(\frac{q+1}{2}\right)^{100} \right]$$

$$\Rightarrow \frac{2^{101} - (q+1)^{101}}{1-q} = \alpha \left[1 \cdot \frac{1 - \left(\frac{q+1}{2}\right)^{101}}{1 - \frac{q+1}{2}} \right]$$

[$\because q \neq 1 \Rightarrow q+1 \neq 2 \Rightarrow \frac{q+1}{2} \neq 1$]

$$= \frac{\alpha [2^{101} - (q+1)^{101}]}{(1-q) \cdot 2^{100}} \Rightarrow \alpha = 2^{100}$$

4. Let the GP be $a, ar, ar^2, ar^3, \dots \infty$; where $a > 0$ and $0 < r < 1$.

Then, according to the problem, we have

$$3 = \frac{a}{1-r}$$

and $\frac{27}{19} = a^3 + (ar)^3 + (ar^2)^3 + (ar^3)^3 + \dots$

$$\Rightarrow \frac{27}{19} = \frac{a^3}{1-r^3} \quad \left[\because S_\infty = \frac{a}{1-r} \right]$$

$$\Rightarrow \frac{27}{19} = \frac{(3(1-r))^3}{1-r^3} \quad \left[\because 3 = \frac{a}{1-r} \Rightarrow a = 3(1-r) \right]$$

$$\Rightarrow \frac{27}{19} = \frac{27(1-r)(1+r^2-2r)}{(1-r)(1+r+r^2)}$$

[$\because (1-r)^3 = (1-r)(1-r)^2$]

$$\Rightarrow r^2 + r + 1 = 19(r^2 - 2r + 1)$$

$$\Rightarrow 18r^2 - 39r + 18 = 0$$

$$\Rightarrow 6r^2 - 13r + 6 = 0$$

$$\Rightarrow (3r-2)(2r-3) = 0$$

$$\therefore r = \frac{2}{3} \text{ or } r = \frac{3}{2} \text{ (reject)} \quad [0 < r < 1]$$

5. Let a, ar, ar^2 are in GP, where ($r > 1$).

On multiplying middle term by 2, we have $a, 2ar, ar^2$ are in an AP.

$$\Rightarrow 4ar = a + ar^2$$

$$\Rightarrow r^2 - 4r + 1 = 0$$

$$\Rightarrow r = \frac{4 \pm \sqrt{16-4}}{2} = 2 \pm \sqrt{3}$$

$$\Rightarrow r = 2 + \sqrt{3} \quad [\text{since, AP is increasing}]$$

6. Given,

$$k \cdot 10^9 = 10^9 + 2(11)^1(10)^8 + 3(11)^2(10)^7 + \dots + 10(11)^9$$

$$\Rightarrow k = 1 + 2\left(\frac{11}{10}\right) + 3\left(\frac{11}{10}\right)^2 + \dots + 10\left(\frac{11}{10}\right)^9 \quad \dots(i)$$

$$\left(\frac{11}{10}\right)k = 1\left(\frac{11}{10}\right) + 2\left(\frac{11}{10}\right)^2 + \dots + 9\left(\frac{11}{10}\right)^9 + 10\left(\frac{11}{10}\right)^{10} \quad \dots(ii)$$

On subtracting Eq. (ii) from Eq. (i), we get

$$k\left(1 - \frac{11}{10}\right) = 1 + \frac{11}{10} + \left(\frac{11}{10}\right)^2 + \dots + \left(\frac{11}{10}\right)^9 - 10\left(\frac{11}{10}\right)^{10}$$

$$\Rightarrow k\left(\frac{10-11}{10}\right) = \frac{1\left[\left(\frac{11}{10}\right)^{10} - 1\right]}{\left(\frac{11}{10} - 1\right)} - 10\left(\frac{11}{10}\right)^{10}$$

[\because In GP, sum of n terms = $\frac{a(r^n - 1)}{r - 1}$, when $r > 1$]

$$\Rightarrow -k = 10\left[10\left(\frac{11}{10}\right)^{10} - 10 - 10\left(\frac{11}{10}\right)^{10}\right]$$

$$\therefore k = 100$$

7. Let $S = 0.7 + 0.77 + 0.777 + \dots$

$$= \frac{7}{10} + \frac{77}{10^2} + \frac{777}{10^3} + \dots \text{ upto 20 terms}$$

$$= 7\left[\frac{1}{10} + \frac{11}{10^2} + \frac{111}{10^3} + \dots \text{ upto 20 terms}\right]$$

$$= \frac{7}{9}\left[\frac{9}{10} + \frac{99}{100} + \frac{999}{1000} + \dots \text{ upto 20 terms}\right]$$

$$= \frac{7}{9}\left[\left(1 - \frac{1}{10}\right) + \left(1 - \frac{1}{10^2}\right) + \left(1 - \frac{1}{10^3}\right) + \dots + \text{ upto 20 terms}\right]$$

$$= \frac{7}{9}[(1+1+\dots \text{ upto 20 terms}) - \left(\frac{1}{10} + \frac{1}{10^2} + \frac{1}{10^3} + \dots + \text{ upto 20 terms}\right)]$$

$$= \frac{7}{9} \left[20 - \frac{1 - \left(\frac{1}{10}\right)^{20}}{1 - \frac{1}{10}} \right]$$

$$\left[\begin{array}{l} \because \sum_{i=1}^{20} = 20 \text{ and sum of } n \text{ terms of} \\ \text{GP, } S_n = \frac{\alpha(1-r^n)}{1-r} \text{ when } (r < 1) \end{array} \right]$$

$$= \frac{7}{9} \left[20 - \frac{1}{9} \left\{ 1 - \left(\frac{1}{10}\right)^{20} \right\} \right]$$

$$= \frac{7}{9} \left[\frac{179}{9} + \frac{1}{9} \left(\frac{1}{10}\right)^{20} \right] = \frac{7}{81} [179 + (10)^{-20}]$$

8. We know that, the sum of infinite terms of GP is

$$S_\infty = \begin{cases} \frac{a}{1-r}, & |r| < 1 \\ \infty, & |r| \geq 1 \end{cases}$$

$$\therefore S_\infty = \frac{x}{1-r} = 5 \quad [|r| < 1]$$

or $1-r = \frac{x}{5}$

$$\Rightarrow r = \frac{5-x}{5} \text{ exists only when } |r| < 1.$$

i.e. $-1 < \frac{5-x}{5} < 1$ or $-10 < -x < 0$

$$\Rightarrow 0 < x < 10$$

9. Since, sum = 4 and second term = $\frac{3}{4}$.

It is given first term a and common ratio r .

$$\Rightarrow \frac{a}{1-r} = 4, ar = \frac{3}{4} \Rightarrow r = \frac{3}{4a}$$

$$\Rightarrow \frac{a}{1 - \frac{3}{4a}} = 4 \Rightarrow \frac{4a^2}{4a-3} = 4$$

$$\Rightarrow (a-1)(a-3) = 0 \Rightarrow a = 1 \text{ or } 3$$

When $a = 1, r = 3/4$

and when $a = 3, r = 1/4$

10. Sum of the n terms of the series $\frac{1}{2} + \frac{3}{4} + \frac{7}{8} + \frac{15}{16} + \dots$

upto n terms can be written as

$$\left(1 - \frac{1}{2}\right) + \left(1 - \frac{1}{4}\right) + \left(1 - \frac{1}{8}\right) + \left(1 - \frac{1}{16}\right) + \dots \text{ upto } n \text{ terms}$$

$$= n - \left(\frac{1}{2} + \frac{1}{4} + \frac{1}{8} + \dots + n \text{ terms}\right)$$

$$= n - \frac{1 - \left(\frac{1}{2}\right)^n}{1 - \frac{1}{2}} = n + 2^{-n} - 1$$

11. Given quadratic equation $x^2 - x - 1 = 0$ having roots α and $\beta, (\alpha > \beta)$

$$\text{So, } \alpha = \frac{1 + \sqrt{5}}{2} \text{ and } \beta = \frac{1 - \sqrt{5}}{2}$$

$$\text{and } \alpha + \beta = 1, \alpha\beta = -1$$

$$\therefore a_n = \frac{\alpha^n - \beta^n}{\alpha - \beta}, n \geq 1$$

$$\text{So, } a_{n+1} = \frac{\alpha^{n+1} - \beta^{n+1}}{\alpha - \beta} = \alpha^n + \alpha^{n-1}\beta + \alpha^{n-2}\beta^2 + \dots$$

$$+ \alpha\beta^{n-1} + \beta^n \quad [\text{as } \alpha\beta = -1]$$

$$= \alpha^n + \beta^n - (\alpha^{n-2} + \alpha^{n-3}\beta + \dots + \beta^{n-2})$$

$$= \alpha^n + \beta^n - a_{n-1}$$

$$\left[\text{as } a_{n-1} = \frac{\alpha^{n-1} - \beta^{n-1}}{\alpha - \beta} = \alpha^{n-2} + \alpha^{n-3}\beta + \dots + \beta^{n-2} \right]$$

$$\Rightarrow a_{n+1} + a_{n-1} = \alpha^n + \beta^n = b_n, \forall n \geq 1$$

So, option (b) is correct.

$$\text{Now, } \sum_{n=1}^{\infty} \frac{b_n}{10^n} = \sum_{n=1}^{\infty} \frac{\alpha^n + \beta^n}{10^n} \quad [\text{as, } b_n = \alpha^n + \beta^n]$$

$$= \sum_{n=1}^{\infty} \left(\frac{\alpha}{10}\right)^n + \sum_{n=1}^{\infty} \left(\frac{\beta}{10}\right)^n \quad \left[\because \left|\frac{\alpha}{10}\right| < 1 \text{ and } \left|\frac{\beta}{10}\right| < 1 \right]$$

$$= \frac{\alpha}{1 - \frac{\alpha}{10}} + \frac{\beta}{1 - \frac{\beta}{10}} = \frac{\alpha}{10 - \alpha} + \frac{\beta}{10 - \beta}$$

$$= \frac{10\alpha - \alpha\beta + 10\beta - \alpha\beta}{(10 - \alpha)(10 - \beta)} = \frac{10(\alpha + \beta) - 2\alpha\beta}{100 - 10(\alpha + \beta) + \alpha\beta}$$

$$= \frac{10(1) - 2(-1)}{100 - 10(1) - 1} = \frac{12}{89} \quad [\text{as } \alpha + \beta = 1 \text{ and } \alpha\beta = -1]$$

So, option (a) is not correct.

$$\therefore \alpha^2 = \alpha + 1 \text{ and } \beta^2 = \beta + 1$$

$$\Rightarrow \alpha^{n+2} = \alpha^{n+1} + \alpha^n \text{ and } \beta^{n+2} = \beta^{n+1} + \beta^n$$

$$\Rightarrow (\alpha^{n+2} + \beta^{n+2}) = (\alpha^{n+1} + \beta^{n+1}) + (\alpha^n + \beta^n)$$

$$\Rightarrow a_{n+2} = a_{n+1} + a_n$$

Similarly, $a_{n+1} = a_n + a_{n-1}$

$$a_n = a_{n-1} + a_{n-2}$$

$$\dots\dots\dots$$

$$\dots\dots\dots$$

$$a_3 = a_2 + a_1$$

On adding, we get

$$a_{n+2} = (a_n + a_{n-1} + a_{n-2} + \dots + a_2 + a_1) + a_2$$

$$\left[\because a_2 = \frac{\alpha^2 - \beta^2}{\alpha - \beta} = \alpha + \beta = 1 \right]$$

$$\text{So, } a_{n+2} - 1 = a_1 + a_2 + a_3 + \dots + a_n$$

So, option (c) is also correct.

$$\text{And, now } \sum_{n=1}^{\infty} \frac{a_n}{10^n} = \sum_{n=1}^{\infty} \frac{\alpha^n - \beta^n}{(\alpha - \beta) 10^n}$$

$$= \frac{1}{\alpha - \beta} \left[\sum_{n=1}^{\infty} \left(\frac{\alpha}{10}\right)^n - \sum_{n=1}^{\infty} \left(\frac{\beta}{10}\right)^n \right]$$

68 Sequences and Series

$$\begin{aligned}
 &= \frac{1}{\alpha - \beta} \left[\frac{\frac{\alpha}{10}}{1 - \frac{\alpha}{10}} - \frac{\frac{\beta}{10}}{1 - \frac{\beta}{10}} \right], \left[\text{as } \left| \frac{\alpha}{10} \right| < 1 \text{ and } \left| \frac{\beta}{10} \right| < 1 \right] \\
 &= \frac{1}{\alpha - \beta} \left(\frac{\alpha}{10 - \alpha} - \frac{\beta}{10 - \beta} \right) = \frac{1}{\alpha - \beta} \left[\frac{10\alpha - \alpha\beta - 10\beta + \alpha\beta}{100 - 10(\alpha + \beta) + \alpha\beta} \right] \\
 &= \frac{10(\alpha - \beta)}{(\alpha - \beta)[100 - 10(\alpha + \beta) + \alpha\beta]} = \frac{10}{100 - 10 - 1} = \frac{10}{89}
 \end{aligned}$$

Hence, options (b), (c) and (d) are correct.

- 12.** Let a_n denotes the length of side of the square S_n .

We are given, $a_n =$ length of diagonal of S_{n+1} .

$$\Rightarrow a_n = \sqrt{2} a_{n+1} \Rightarrow a_{n+1} = \frac{a_n}{\sqrt{2}}$$

This shows that a_1, a_2, a_3, \dots form a GP with common ratio $1/\sqrt{2}$.

$$\text{Therefore, } a_n = a_1 \left(\frac{1}{\sqrt{2}} \right)^{n-1}$$

$$\Rightarrow a_n = 10 \left(\frac{1}{\sqrt{2}} \right)^{n-1} \quad [\because a_1 = 10, \text{ given}]$$

$$\Rightarrow a_n^2 = 100 \left(\frac{1}{\sqrt{2}} \right)^{2(n-1)} \Rightarrow \frac{100}{2^{n-1}} \leq 1 \quad [\because a_n^2 \leq 1, \text{ given}]$$

$$\Rightarrow 100 \leq 2^{n-1}$$

This is possible for $n \geq 8$.

Hence, (b), (c), (d) are the correct answers.

- 13.** $B_n = 1 - A_n > A_n$

$$\Rightarrow A_n < \frac{1}{2} \Rightarrow \frac{3 \left(1 - \left(-\frac{3}{4} \right)^n \right)}{1 + \frac{3}{4}} < \frac{1}{2}$$

$$\Rightarrow \left(-\frac{3}{4} \right)^n > -\frac{1}{6}$$

Obviously, it is true for all even values of n .

But for

$$n = 1, \quad -\frac{3}{4} < -\frac{1}{6}$$

$$n = 3, \quad \left(-\frac{3}{4} \right)^3 = -\frac{27}{64} < -\frac{1}{6}$$

$$n = 5, \quad \left(-\frac{3}{4} \right)^5 = -\frac{243}{1024} < -\frac{1}{6}$$

and for $n = 7$,

$$\left(-\frac{3}{4} \right)^7 = -\frac{2187}{12288} > -\frac{1}{6}$$

Hence, minimum odd natural number $n_0 = 7$.

- 14.** Consider an infinite GP with first term 1, 2, 3, ..., n and common ratios $\frac{1}{2}, \frac{1}{3}, \frac{1}{4}, \dots, \frac{1}{n+1}$.

$$\therefore S_1 = \frac{1}{1 - 1/2} = 2$$

$$S_2 = \frac{2}{1 - 1/3} = 3$$

$$\vdots \quad \vdots \quad \vdots$$

$$S_{2n-1} = \frac{2n-1}{1 - 1/2n} = 2n$$

$$\begin{aligned}
 \therefore S_1^2 + S_2^2 + S_3^2 + \dots + S_{2n-1}^2 &= 2^2 + 3^2 + 4^2 + \dots + (2n)^2 \\
 &= \frac{1}{6} (2n)(2n+1)(4n+1) - 1
 \end{aligned}$$

- 15.** Let three numbers in GP be a, ar, ar^2 .

$$\therefore a^2 + a^2 r^2 + a^2 r^4 = S^2 \quad \dots(i)$$

$$\text{and } a + ar + ar^2 = aS \quad \dots(ii)$$

On dividing Eq. (i) by Eq. (ii) after squaring it, we get

$$\frac{a^2(1+r^2+r^4)}{a^2(1+r+ar)^2} = \frac{S^2}{a^2 S^2} \Rightarrow \frac{(1+r^2)^2 - r^2}{(1+r+r^2)^2} = \frac{1}{a^2}$$

$$\Rightarrow \frac{(1+r^2-r)}{(1+r^2+r)} = \frac{1}{a^2} \Rightarrow a^2 = \frac{r + \frac{1}{r} + 1}{r + \frac{1}{r} - 1}$$

$$\text{Put } r + \frac{1}{r} = y \Rightarrow \frac{y+1}{y-1} = a^2$$

$$\Rightarrow y+1 = a^2 y - a^2$$

$$\Rightarrow y = \frac{a^2 + 1}{a^2 - 1} \quad \left[\because |y| = \left| r + \frac{1}{r} \right| > 2 \right]$$

$$\Rightarrow \left| \frac{a^2 + 1}{a^2 - 1} \right| > 2 \quad [\text{where } (a^2 - 1) \neq 0]$$

$$\Rightarrow |a^2 + 1| > 2|a^2 - 1|$$

$$\Rightarrow (a^2 + 1)^2 - \{2(a^2 - 1)\}^2 > 0$$

$$\Rightarrow \{(a^2 + 1) - 2(a^2 - 1)\} \{(a^2 + 1) + 2(a^2 - 1)\} > 0$$

$$\Rightarrow (-a^2 + 3)(3a^2 - 1) > 0$$

$$\therefore \frac{1}{3} < a^2 < 3$$

$$\therefore a^2 \in \left(\frac{1}{3}, 1 \right) \cup (1, 3) \quad [\because a^2 \neq 1]$$

- 16.** We have, $S_k = \frac{k!}{1 - \frac{1}{k}} = \frac{1}{(k-1)!}$

$$\begin{aligned}
 \text{Now, } (k^2 - 3k + 1)S_k &= \{(k-2)(k-1) - 1\} \times \frac{1}{(k-1)!} \\
 &= \frac{1}{(k-3)!} - \frac{1}{(k-1)!}
 \end{aligned}$$

$$\Rightarrow \sum_{k=1}^{100} |(k^2 - 3k + 1)S_k| = 1 + 1 + 2 - \left(\frac{1}{99!} + \frac{1}{98!} \right) = 4 - \frac{100^2}{100!}$$

$$\Rightarrow \frac{100^2}{100!} + \sum_{k=1}^{100} |(k^2 - 3k + 1)S_k| = 4$$

Topic 5 Harmonic Progression (HP)

1. **PLAN** n th term of HP, $t_n = \frac{1}{a + (n-1)d}$

Here, $a_1 = 5, a_{20} = 25$ for HP

$$\therefore \frac{1}{a} = 5 \text{ and } \frac{1}{a + 19d} = 25$$

$$\Rightarrow \frac{1}{5} + 19d = \frac{1}{25} \Rightarrow 19d = \frac{1}{25} - \frac{1}{5} = -\frac{4}{25}$$

$$\therefore d = \frac{-4}{19 \times 25}$$

$$\text{Since, } a_n < 0 \Rightarrow \frac{1}{5} + (n-1)d < 0$$

$$\Rightarrow \frac{1}{5} - \frac{4}{19 \times 25}(n-1) < 0 \Rightarrow (n-1) > \frac{95}{4}$$

$$\Rightarrow n > 1 + \frac{95}{4} \text{ or } n > 24.75$$

\therefore Least positive value of $n = 25$

2. Since, a, b, c, d are in AP.

$$\Rightarrow \frac{a}{abcd}, \frac{b}{abcd}, \frac{c}{abcd}, \frac{d}{abcd} \text{ are in AP.}$$

$$\Rightarrow \frac{1}{bcd}, \frac{1}{cda}, \frac{1}{abd}, \frac{1}{abc} \text{ are in AP.}$$

$$\Rightarrow bcd, cda, abd, abc \text{ are in HP.}$$

$$\Rightarrow abc, abd, cda, bcd \text{ are in HP.}$$

3. Since, $a_1, a_2, a_3, \dots, a_{10}$ are in AP.

$$\text{Now, } a_{10} = a_1 + 9d \Rightarrow 3 = 2 + 9d$$

$$\Rightarrow d = 1/9 \text{ and } a_4 = a_1 + 3d$$

$$\Rightarrow a_4 = 2 + 3(1/9) = 2 + 1/3 = 7/3$$

Also, $h_1, h_2, h_3, \dots, h_{10}$ are in HP.

$$\Rightarrow \frac{1}{h_1}, \frac{1}{h_2}, \frac{1}{h_3}, \dots, \frac{1}{h_{10}} \text{ are in AP.}$$

$$\text{Given, } h_1 = 2, h_{10} = 3$$

$$\therefore \frac{1}{h_{10}} = \frac{1}{h_1} + 9d_1 \Rightarrow \frac{1}{3} = \frac{1}{2} + 9d_1 \Rightarrow -\frac{1}{6} = 9d_1$$

$$\Rightarrow d_1 = -\frac{1}{54} \text{ and } \frac{1}{h_7} = \frac{1}{h_1} + 6d_1$$

$$\Rightarrow \frac{1}{h_7} = \frac{1}{2} + \frac{6 \times 1}{-54}$$

$$\Rightarrow \frac{1}{h_7} = \frac{1}{2} - \frac{1}{9} \Rightarrow h_7 = \frac{18}{7}$$

$$\therefore a_4 h_7 = \frac{7}{3} \times \frac{18}{7} = 6$$

4. Let the common ratio of the GP be r . Then,

$$y = xr \text{ and } z = xr^2$$

$$\Rightarrow \ln y = \ln x + \ln r \text{ and } \ln z = \ln x + 2 \ln r$$

$$\text{Let } A = 1 + \ln x, D = \ln r$$

$$\text{Then, } \frac{1}{1 + \ln x} = \frac{1}{A}, \frac{1}{1 + \ln y} = \frac{1}{1 + \ln x + \ln r} = \frac{1}{A + D}$$

$$\text{and } \frac{1}{1 + \ln z} = \frac{1}{1 + \ln x + 2 \ln r} = \frac{1}{A + 2D}$$

Therefore, $\frac{1}{1 + \ln x}, \frac{1}{1 + \ln y}, \frac{1}{1 + \ln z}$ are in HP.

5. Let $a_1 = 1, a_2 = 2, \Rightarrow a_3 = 4, a_4 = 8$

$$\therefore b_1 = 1, b_2 = 3, b_3 = 7, b_4 = 15$$

Clearly, b_1, b_2, b_3, b_4 are not in HP.

Hence, Statement II is false.

Statement I is already true.

6. Since, $\cos(x-y), \cos x$ and $\cos(x+y)$ are in HP.

$$\therefore \cos x = \frac{2 \cos(x-y) \cos(x+y)}{\cos(x-y) + \cos(x+y)}$$

$$\Rightarrow \cos x (2 \cos x \cdot \cos y) = 2 \{\cos^2 x - \sin^2 y\}$$

$$\Rightarrow \cos^2 x \cdot \cos y = \cos^2 x - \sin^2 y$$

$$\Rightarrow \cos^2 x (1 - \cos y) = \sin^2 y$$

$$\Rightarrow \cos^2 x \cdot 2 \sin^2 \frac{y}{2} = 4 \sin^2 \frac{y}{2} \cdot \cos^2 \frac{y}{2}$$

$$\Rightarrow \cos^2 x \cdot \sec^2 \frac{y}{2} = 2 \Rightarrow \cos x \cdot \sec \frac{y}{2} = \pm \sqrt{2}$$

7. Since, a, b, c are in an AP.

$$\therefore 2b = a + c$$

and a^2, b^2, c^2 are in HP.

$$\Rightarrow b^2 = \frac{2a^2 c^2}{a^2 + c^2} \Rightarrow \left(\frac{a+c}{2}\right)^2 = \frac{2a^2 c^2}{a^2 + c^2}$$

$$\Rightarrow (a^2 + c^2)(a^2 + c^2 + 2ac) = 8a^2 c^2$$

$$\Rightarrow (a^2 + c^2) + 2ac(a^2 + c^2) = 8a^2 c^2$$

$$\Rightarrow (a^2 + c^2) + 2ac(a^2 + c^2) + a^2 c^2 = 9a^2 c^2$$

$$\Rightarrow (a^2 + c^2 + ac)^2 = 9a^2 c^2$$

$$\Rightarrow a^2 + c^2 + ac = 3ac$$

$$\Rightarrow a^2 + b^2 - 2ac = 0$$

$$\Rightarrow (a-c)^2 = 0 \Rightarrow a = c$$

and if $a = c \Rightarrow b = c$ or $a^2 + c^2 + ac = -3ac$

$$\Rightarrow a^2 + c^2 + 2ac = -2ac$$

$$\Rightarrow (a+c)^2 = -2ac$$

$$\Rightarrow 4b^2 = -2ac \Rightarrow b^2 = -\frac{ac}{2}$$

Hence, $a, b, -\frac{c}{2}$ are in GP.

\therefore Either $a = b = c$ or $a, b, -\frac{c}{2}$ are in GP.

8. Since, a, A_1, A_2, b are in AP.

$$\Rightarrow A_1 + A_2 = a + b$$

$$a, G_1, G_2, b \text{ are in GP} \Rightarrow G_1 G_2 = ab$$

and a, H_1, H_2, b are in HP.

$$\Rightarrow H_1 = \frac{3ab}{2b+a}, H_2 = \frac{3ab}{b+2a}$$

$$\therefore \frac{1}{H_1} + \frac{1}{H_2} = \frac{1}{a} + \frac{1}{b}$$

70 Sequences and Series

$$\Rightarrow \frac{H_1 + H_2}{H_1 H_2} = \frac{A_1 + A_2}{G_1 G_2} = \frac{1}{a} + \frac{1}{b} \quad \dots(i)$$

$$\text{Now, } \frac{G_1 G_2}{H_1 H_2} = \frac{ab}{\left(\frac{3ab}{2b+a}\right)\left(\frac{3ab}{b+2a}\right)} = \frac{(2a+b)(a+2b)}{9ab} \quad \dots(ii)$$

From Eqs. (i) and (ii), we get

$$\frac{G_1 G_2}{H_1 H_2} = \frac{A_1 + A_2}{H_1 + H_2} = \frac{(2a+b)(a+2b)}{9ab}$$

$$\begin{aligned} 9. \text{ (i) Now, } a + b &= (a + x + y + z + b) - (x + y + z) \\ &= \frac{5}{2}(a + b) - 15 \end{aligned}$$

[since, a, x, y, z are in AP]

$$\therefore \text{ Sum} = \frac{5}{2}(a + b)$$

$$\Rightarrow a + b = 10 \quad \dots(i)$$

Since, a, x, y, z, b are in HP, then $\frac{1}{a}, \frac{1}{x}, \frac{1}{y}, \frac{1}{z}, \frac{1}{b}$ are in AP.

$$\begin{aligned} \text{Now, } \frac{1}{a} + \frac{1}{b} &= \left(\frac{1}{a} + \frac{1}{x} + \frac{1}{y} + \frac{1}{z} + \frac{1}{b}\right) - \left(\frac{1}{x} + \frac{1}{y} + \frac{1}{z}\right) \\ &= \frac{5}{2} \left(\frac{1}{a} + \frac{1}{b}\right) - \frac{5}{3} \Rightarrow \frac{a+b}{ab} = \frac{10}{9} \end{aligned}$$

$$\Rightarrow ab = \frac{9 \times 10}{10} \quad \text{[from Eq. (i)]}$$

$$\Rightarrow ab = 9 \quad \dots(ii)$$

On solving Eqs. (i) and (ii), we get

$$a = 1, b = 9$$

$$(ii) \text{ LHS} = \log(x+z) + \log(x+z-2y)$$

$$= \log(x+z) + \log\left[x+z-2\left(\frac{2xz}{x+z}\right)\right] \quad \left[\because y = \frac{2xz}{x+z}\right]$$

$$= \log(x+z) + \log\frac{(x-z)^2}{(x+z)}$$

$$= 2 \log(x-z) = \text{RHS}$$

Topic 6 Relation between AM, GM, HM and Some Special Series

1. Given series,

$$\begin{aligned} S &= 1 + \frac{1^3 + 2^3}{1+2} + \frac{1^3 + 2^3 + 3^3}{1+2+3} + \dots + \\ &\frac{1^3 + 2^3 + 3^3 + \dots + 15^3}{1+2+3+\dots+15} - \frac{1}{2}(1+2+3+\dots+15) \\ &= S_1 - S_2 \text{ (let)} \end{aligned}$$

where,

$$S_1 = 1 + \frac{1^3 + 2^3}{1+2} + \frac{1^3 + 2^3 + 3^3}{1+2+3} + \dots + \frac{1^3 + 2^3 + 3^3 + \dots + 15^3}{1+2+3+\dots+15}$$

$$\begin{aligned} &= \sum_{n=1}^{15} \frac{1^3 + 2^3 + \dots + n^3}{1+2+\dots+n} = \sum_{n=1}^{15} \frac{\left(\frac{n(n+1)}{2}\right)^2}{\frac{n(n+1)}{2}} \\ &\left[\because \sum_{r=1}^n r^3 = \left(\frac{n(n+1)}{2}\right)^2 \text{ and } \sum_{r=1}^n r = \frac{n(n+1)}{2}\right] \\ &= \sum_{n=1}^{15} \frac{n(n+1)}{2} = \frac{1}{2} \sum_{n=1}^{15} (n^2 + n) \\ &= \frac{1}{2} \left[\frac{15 \times 16 \times 31}{6} + \frac{15 \times 16}{2} \right] \\ &\left[\because \sum_{r=1}^n r^2 = \frac{n(n+1)(2n+1)}{6}\right] \end{aligned}$$

$$= \frac{1}{2} [(5 \times 8 \times 31) + (15 \times 8)]$$

$$= (5 \times 4 \times 31) + (15 \times 4) = 620 + 60 = 680$$

$$\text{and } S_2 = \frac{1}{2}(1+2+3+\dots+15) = \frac{1}{2} \times \frac{15 \times 16}{2} = 60$$

Therefore, $S = S_1 - S_2 = 680 - 60 = 620$.

2. Given series is

$$\frac{3 \times 1^3}{1^2} + \frac{5 \times (1^3 + 2^3)}{1^2 + 2^2} + \frac{7 \times (1^3 + 2^3 + 3^3)}{1^2 + 2^2 + 3^2} + \dots$$

So, n th term

$$T_n = \frac{(3 + (n-1)2)(1^3 + 2^3 + 3^3 \dots + n^3)}{1^2 + 2^2 + 3^2 + \dots + n^2}$$

$$= \frac{(2n+1) \times \left(\frac{n(n+1)}{2}\right)^2}{\frac{n(n+1)(2n+1)}{6}}$$

$$\left[\because \sum_{r=1}^n r^3 = \left[\frac{n(n+1)}{2}\right]^2 \text{ and } \sum_{r=1}^n r^2 = \frac{n(n+1)(2n+1)}{6}\right]$$

$$\text{So, } T_n = \frac{3n(n+1)}{2} = \frac{3}{2}(n^2 + n)$$

Now, sum of the given series upto n terms

$$\begin{aligned} S_n &= \sum T_n = \frac{3}{2} [\sum n^2 + \sum n] \\ &= \frac{3}{2} \left[\frac{n(n+1)(2n+1)}{6} + \frac{n(n+1)}{2} \right] \end{aligned}$$

$$\begin{aligned} \therefore S_{10} &= \frac{3}{2} \left[\frac{10 \times 11 \times 21}{6} + \frac{10 \times 11}{2} \right] \\ &= \frac{3}{2} [(5 \times 11 \times 7) + (5 \times 11)] \\ &= \frac{3}{2} \times 55(7+1) = \frac{3}{2} \times 55 \times 8 = 3 \times 55 \times 4 \\ &= 12 \times 55 = 660 \end{aligned}$$

3. (b) Given series is

$$1 + (2 \times 3) + (3 \times 5) + (4 \times 7) + \dots \text{ upto } 11 \text{ terms.}$$

Now, the r th term of the series is $a_r = r(2r-1)$

\therefore Sum of first 11-terms is

$$\begin{aligned}
 S_{11} &= \sum_{r=1}^{11} r(2r-1) = \sum_{r=1}^{11} (2r^2-r) = 2 \sum_{r=1}^{11} r^2 - \sum_{r=1}^{11} r \\
 &= 2 \frac{11 \times (11+1)(2 \times 11+1)}{6} - \frac{11 \times (11+1)}{2} \\
 &= \left[\because \sum_{r=1}^n r^2 = \frac{n(n+1)(2n+1)}{6} \text{ and } \sum_{r=1}^n r = \frac{n(n+1)}{2} \right] \\
 &= \left(\frac{11 \times 12 \times 23}{3} \right) - \left(\frac{11 \times 12}{2} \right) \\
 &= (11 \times 4 \times 23) - (11 \times 6) = 11(92-6) = 11 \times 86 = 946
 \end{aligned}$$

4. Given series is

$$\begin{aligned}
 &\left(\frac{3}{4}\right)^3 + \left(1\frac{1}{2}\right)^3 + \left(2\frac{1}{4}\right)^3 + 3^3 + \left(3\frac{3}{4}\right)^3 + \dots \\
 \text{Let } S &= \left(\frac{3}{4}\right)^3 + \left(\frac{6}{4}\right)^3 + \left(\frac{9}{4}\right)^3 + \left(\frac{12}{4}\right)^3 \\
 &\quad + \left(\frac{15}{4}\right)^3 + \dots + \text{upto } 15 \text{ terms} \\
 &= \left(\frac{3}{4}\right)^3 [1^3 + 2^3 + 3^3 + 4^3 + 5^3 + \dots + 15^3] \\
 &= \left(\frac{3}{4}\right)^3 \left(\frac{15 \times 16}{2}\right)^2 \\
 &\quad \left[\because 1^3 + 2^3 + 3^3 + \dots + n^3 = \left(\frac{n(n+1)}{2}\right)^2, n \in N \right] \\
 &= \frac{27}{64} \times \frac{225 \times 256}{4} = 27 \times 225 \\
 \Rightarrow S &= 27 \times 225 = 225k \quad \text{[given]} \\
 \Rightarrow k &= 27.
 \end{aligned}$$

5. Since, $S_k = \frac{1+2+3+\dots+k}{k}$
 $= \frac{k(k+1)}{2k} = \frac{k+1}{2}$

So, $S_k^2 = \left(\frac{k+1}{2}\right)^2 = \frac{1}{4}(k+1)^2 \quad \dots (i)$

Now, $\frac{5}{12}A = S_1^2 + S_2^2 + S_3^2 + \dots + S_{10}^2 = \sum_{k=1}^{10} S_k^2$
 $\Rightarrow \frac{5}{12}A = \frac{1}{4} \sum_{k=1}^{10} (k+1)^2 = \frac{1}{4} [2^2 + 3^2 + 4^2 + \dots + 11^2]$
 $= \frac{1}{4} \left[\frac{11 \times (11+1)(2 \times 11+1)}{6} - 1^2 \right]$
 $[\because \sum n^2 = \frac{n(n+1)(2n+1)}{6}]$
 $= \frac{1}{4} \left[\frac{11 \times 12 \times 23}{6} - 1 \right] = \frac{1}{4} [(22 \times 23) - 1]$
 $= \frac{1}{4} [506 - 1] = \frac{1}{4} [505] \Rightarrow \frac{5}{12}A = \frac{505}{4} \Rightarrow A = 303$

6. Consider, $\frac{x^m y^n}{(1+x^{2m})(1+y^{2n})} = \frac{1}{(x^m+x^{-m})(y^n+y^{-n})}$
 By using AM \geq GM (because $x, y \in R^+$), we get

$$\begin{aligned}
 (x^m + x^{-m}) &\geq 2 \text{ and } (y^n + y^{-n}) \geq 2 \\
 &[\because \text{If } x > 0, \text{ then } x + \frac{1}{x} \geq 2] \\
 \Rightarrow (x^m + x^{-m})(y^n + y^{-n}) &\geq 4 \\
 \Rightarrow \frac{1}{(x^m + x^{-m})(y^n + y^{-n})} &\leq \frac{1}{4} \\
 \therefore \text{Maximum value} &= \frac{1}{4}.
 \end{aligned}$$

7. General term of the given series is

$$\begin{aligned}
 T_r &= \frac{3r(1^2 + 2^2 + \dots + r^2)}{2r+1} = \frac{3r[r(r+1)(2r+1)]}{6(2r+1)} \\
 &= \frac{1}{2}(r^3 + r^2)
 \end{aligned}$$

Now, required sum = $\sum_{r=1}^{15} T_r = \frac{1}{2} \sum_{r=1}^{15} (r^3 + r^2)$
 $= \frac{1}{2} \left\{ \left[\frac{n(n+1)}{2} \right]^2 + \frac{n(n+1)(2n+1)}{6} \right\}_{n=15}$
 $= \frac{1}{2} \left\{ \frac{n(n+1)}{2} \left[\frac{n^2+n}{2} + \frac{2n+1}{3} \right] \right\}_{n=15}$
 $= \frac{1}{2} \left\{ \frac{n(n+1)(3n^2+7n+2)}{6} \right\}_{n=15}$
 $= \frac{1}{2} \times \frac{15 \times 16}{2} \times \frac{(3 \times 225 + 105 + 2)}{6} = 7820$

8. We have, $a_1, a_2, a_3, \dots, a_{49}$ are in AP.

$$\sum_{k=0}^{12} a_{4k+1} = 416 \text{ and } a_9 + a_{43} = 66$$

Let $a_1 = a$ and d = common difference

$$\begin{aligned}
 \therefore a_1 + a_5 + a_9 + \dots + a_{49} &= 416 \\
 \therefore a + (a+4d) + (a+8d) + \dots + (a+48d) &= 416 \\
 \Rightarrow \frac{13}{2}(2a+48d) &= 416 \quad 33a + 24d = 32 \quad \dots (i)
 \end{aligned}$$

Also $a_9 + a_{43} = 66 \Rightarrow a + 8d + a + 42d = 66$
 $\Rightarrow 2a + 50d = 66 \Rightarrow a + 25d = 33 \quad \dots (ii)$

Solving Eqs. (i) and (ii), we get

$$\begin{aligned}
 a &= 8 \text{ and } d = 1 \\
 \text{Now, } a_1^2 + a_2^2 + a_3^2 + \dots + a_{17}^2 &= 140m \\
 8^2 + 9^2 + 10^2 + \dots + 24^2 &= 140m \\
 \Rightarrow (1^2 + 2^2 + 3^2 + \dots + 24^2) - (1^2 + 2^2 + 3^2 + \dots + 7^2) &= 140m \\
 \Rightarrow \frac{24 \times 25 \times 49}{6} - \frac{7 \times 8 \times 15}{6} &= 140m \\
 \Rightarrow \frac{3 \times 7 \times 8 \times 5}{6} (7 \times 5 - 1) &= 140m \\
 \Rightarrow 7 \times 4 \times 5 \times 34 &= 140m \\
 \Rightarrow 140 \times 34 &= 140m \Rightarrow m = 34
 \end{aligned}$$

9. We have,

$$\begin{aligned}
 &1^2 + 2 \cdot 2^2 + 3^2 + 2 \cdot 4^2 + 5^2 + 2 \cdot 6^2 + \dots \\
 A &= \text{sum of first 20 terms} \\
 B &= \text{sum of first 40 terms}
 \end{aligned}$$

72 Sequences and Series

$$\begin{aligned} \therefore A &= 1^2 + 2 \cdot 2^2 + 3^2 + 2 \cdot 4^2 + 5^2 + 2 \cdot 6^2 + \dots + 2 \cdot 20^2 \\ A &= (1^2 + 2^2 + 3^2 + \dots + 20^2) + (2^2 + 4^2 + 6^2 + \dots + 20^2) \\ A &= (1^2 + 2^2 + 3^2 + \dots + 20^2) + 4(1^2 + 2^2 + 3^2 + \dots + 10^2) \\ A &= \frac{20 \times 21 \times 41}{6} + \frac{4 \times 10 \times 11 \times 21}{6} \\ A &= \frac{20 \times 21}{6} (41 + 22) = \frac{20 \times 41 \times 63}{6} \end{aligned}$$

Similarly

$$\begin{aligned} B &= (1^2 + 2^2 + 3^2 + \dots + 40^2) + 4(1^2 + 2^2 + \dots + 20^2) \\ B &= \frac{40 \times 41 \times 81}{6} + \frac{4 \times 20 \times 21 \times 41}{6} \\ B &= \frac{40 \times 41}{6} (81 + 42) = \frac{40 \times 41 \times 123}{6} \end{aligned}$$

Now, $B - 2A = 100\lambda$

$$\begin{aligned} \therefore \frac{40 \times 41 \times 123}{6} - \frac{2 \times 20 \times 21 \times 63}{6} &= 100\lambda \\ \Rightarrow \frac{40}{6} (5043 - 1323) &= 100\lambda \Rightarrow \frac{40}{6} \times 3720 = 100\lambda \\ \Rightarrow 40 \times 620 &= 100\lambda \Rightarrow \lambda = \frac{40 \times 620}{100} = 248 \end{aligned}$$

10. Let S_{10} be the sum of first ten terms of the series. Then, we have

$$\begin{aligned} S_{10} &= \left(1 \frac{3}{5}\right)^2 + \left(2 \frac{2}{5}\right)^2 + \left(3 \frac{1}{5}\right)^2 + 4^2 + \left(4 \frac{4}{5}\right)^2 \\ &\quad + \dots \text{ to 10 terms} \\ &= \left(\frac{8}{5}\right)^2 + \left(\frac{12}{5}\right)^2 + \left(\frac{16}{5}\right)^2 + 4^2 + \left(\frac{24}{5}\right)^2 + \dots \text{ to 10 terms} \\ &= \frac{1}{5^2} (8^2 + 12^2 + 16^2 + 20^2 + 24^2 + \dots \text{ to 10 terms}) \\ &= \frac{4^2}{5^2} (2^2 + 3^2 + 4^2 + 5^2 + \dots \text{ to 10 terms}) \\ &= \frac{4^2}{5^2} (2^2 + 3^2 + 4^2 + 5^2 + \dots + 11^2) \\ &= \frac{16}{25} ((1^2 + 2^2 + \dots + 11^2) - 1^2) \\ &= \frac{16}{25} \left(\frac{11 \cdot (11 + 1) (2 \cdot 11 + 1)}{6} - 1 \right) \\ &= \frac{16}{25} (506 - 1) = \frac{16}{25} \times 505 \Rightarrow \frac{16}{5} m = \frac{16}{25} \times 505 = 101 \end{aligned}$$

11. Given, m is the AM of l and n .

$$\therefore l + n = 2m \quad \dots (i)$$

and G_1, G_2, G_3 are geometric means between l and n .

l, G_1, G_2, G_3, n are in GP.

Let r be the common ratio of this GP.

$$\therefore G_1 = lr, G_2 = lr^2, G_3 = lr^3, n = lr^4 \Rightarrow r = \left(\frac{n}{l}\right)^{\frac{1}{4}}$$

$$\begin{aligned} \text{Now, } G_1^4 + 2G_2^4 + G_3^4 &= (lr)^4 + 2(lr^2)^4 + (lr^3)^4 \\ &= l^4 \times r^4 (1 + 2r^4 + r^6) = l^4 \times r^4 (r^4 + 1)^2 \\ &= l^4 \times \frac{n}{l} \left(\frac{n+l}{l}\right)^2 = ln \times 4m^2 = 4lm^2n \end{aligned}$$

12. **PLAN** Write the n th term of the given series and simplify it to get its lowest form. Then, apply, $S_n = \sum T_n$

$$\text{Given series is } \frac{1^3}{1} + \frac{1^3 + 2^3}{1+3} + \frac{1^3 + 2^3 + 3^3}{1+3+5} + \dots$$

Let T_n be the n th term of the given series.

$$\begin{aligned} \therefore T_n &= \frac{1^3 + 2^3 + 3^3 + \dots + n^3}{1 + 3 + 5 + \dots \text{ upto } n \text{ terms}} \\ &= \frac{\left\{ \frac{n(n+1)}{2} \right\}^2}{\frac{n^2}{4}} = \frac{(n+1)^2}{4} \end{aligned}$$

$$\begin{aligned} S_9 &= \sum_{n=1}^9 \frac{(n+1)^2}{4} = \frac{1}{4} (2^2 + 3^2 + \dots + 10^2) + 1^2 - 1^2 \\ &= \frac{1}{4} \left[\frac{10(10+1)(20+1)}{6} - 1 \right] = \frac{384}{4} = 96 \end{aligned}$$

13. Here, $\alpha \in (0, \frac{\pi}{2}) \Rightarrow \tan \alpha > 0$

$$\begin{aligned} \therefore \frac{\sqrt{x^2 + x} + \frac{\tan^2 \alpha}{\sqrt{x^2 + x}}}{2} &\geq \sqrt{\sqrt{x^2 + x} \cdot \frac{\tan^2 \alpha}{\sqrt{x^2 + x}}} \\ &\quad \text{[using AM} \geq \text{GM]} \end{aligned}$$

$$\Rightarrow \sqrt{x^2 + x} + \frac{\tan^2 \alpha}{\sqrt{x^2 + x}} \geq 2 \tan \alpha$$

14. Given, $a_1 a_2 a_3 \dots a_n = c$

$$\Rightarrow a_1 a_2 a_3 \dots (a_{n-1})(2a_n) = 2c \quad \dots (i)$$

$$\therefore \frac{a_1 + a_2 + a_3 + \dots + 2a_n}{n} \geq (a_1 \cdot a_2 \cdot a_3 \dots 2a_n)^{1/n}$$

[using AM \geq GM]

$$\Rightarrow a_1 + a_2 + a_3 + \dots + 2a_n \geq n(2c)^{1/n} \quad \text{[from Eq. (i)]}$$

\Rightarrow Minimum value of

$$a_1 + a_2 + a_3 + \dots + 2a_n = n(2c)^{1/n}$$

15. Since, AM \geq GM, then

$$\frac{(a+b) + (c+d)}{2} \geq \sqrt{(a+b)(c+d)} \Rightarrow M \leq 1$$

Also, $(a+b) + (c+d) > 0$ [$\because a, b, c, d > 0$]

$$\therefore 0 < M \leq 1$$

16. Let α, β be the roots of given quadratic equation. Then,

$$\alpha + \beta = \frac{4 + \sqrt{5}}{5 + \sqrt{2}} \quad \text{and} \quad \alpha \beta = \frac{8 + 2\sqrt{5}}{5 + \sqrt{2}}$$

Let H be the harmonic mean between α and β , then

$$H = \frac{2\alpha\beta}{\alpha + \beta} = \frac{16 + 4\sqrt{5}}{4 + \sqrt{5}} = 4$$

17. Since, product of n positive numbers is unity.

$$\Rightarrow x_1 \cdot x_2 \cdot x_3 \dots x_n = 1 \quad \dots (i)$$

$$\text{Using AM} \geq \text{GM, } \frac{x_1 + x_2 + \dots + x_n}{n} \geq (x_1 \cdot x_2 \dots x_n)^{1/n}$$

$$\Rightarrow x_1 + x_2 + \dots + x_n \geq n(1)^{1/n} \quad \text{[from Eq. (i)]}$$

Hence, sum of n positive numbers is never less than n .

18. Since, AM > GM

$$\therefore \frac{(b+c-a)+(c+a-b)}{2} > (b+c-a)(c+a-b)^{1/2}$$

$$\Rightarrow c > [(b+c-a)(c+a-b)]^{1/2} \quad \dots(i)$$

Similarly $b > [(a+b-c)(b+c-a)]^{1/2} \quad \dots(ii)$

and $a > [(a+b-c)(c+a-b)]^{1/2} \quad \dots(iii)$

On multiplying Eqs. (i), (ii) and (iii), we get
 $abc > (a+b-c)(b+c-a)(c+a-b)$

Hence, $(a+b-c)(b+c-a)(c+a-b) - abc < 0$

19. Since, x_1, x_2, \dots, x_n are positive real numbers.

\therefore Using n th power mean inequality

$$\frac{x_1^2 + x_2^2 + \dots + x_n^2}{n} \geq \left(\frac{x_1 + x_2 + \dots + x_n}{n} \right)^2$$

$$\Rightarrow \frac{n^2}{n} \left(\sum_{i=1}^n x_i^2 \right) \geq \left(\sum_{i=1}^n x_i \right)^2 \Rightarrow n \left(\sum_{i=1}^n x_i^2 \right) \geq \left(\sum_{i=1}^n x_i \right)^2$$

20. Let a and b are two numbers. Then,

$$A_1 = \frac{a+b}{2}; G_1 = \sqrt{ab}; H_1 = \frac{2ab}{a+b}$$

$$A_n = \frac{A_{n-1} + H_{n-1}}{2}, G_n = \sqrt{A_{n-1}H_{n-1}},$$

$$H_n = \frac{2A_{n-1}H_{n-1}}{A_{n-1} + H_{n-1}}$$

Clearly, $G_1 = G_2 = G_3 = \dots = \sqrt{ab}$.

21. A_2 is AM of A_1 and H_1 and $A_1 > H_1$

$$\Rightarrow A_1 > A_2 > H_1$$

A_3 is AM of A_2 and H_2 and $A_2 > H_2$

$$\Rightarrow A_2 > A_3 > H_2$$

$$\vdots \quad \vdots \quad \vdots$$

$$\therefore A_1 > A_2 > A_3 > \dots$$

22. As above, $A_1 > H_2 > H_1, A_2 > H_3 > H_2$

$$\therefore H_1 < H_2 < H_3 < \dots$$

23. Given, $a(n) = 1 + \frac{1}{2} + \frac{1}{3} + \frac{1}{4} + \dots + \frac{1}{2^n - 1}$

$$= 1 + \left(\frac{1}{2} + \frac{1}{3} \right) + \left(\frac{1}{4} + \dots + \frac{1}{7} \right) + \left(\frac{1}{8} + \dots + \frac{1}{15} \right)$$

$$+ \dots + \left(\frac{1}{2^{n-1}} + \dots + \frac{1}{2^n - 1} \right)$$

$$< 1 + \left(\frac{1}{2} + \frac{1}{2} \right) + \left(\frac{1}{4} + \frac{1}{4} + \dots + \frac{1}{4} \right) + \left(\frac{1}{8} + \frac{1}{8} + \dots + \frac{1}{8} \right)$$

$$+ \dots + \left(\frac{1}{2^{n-1}} + \dots + \frac{1}{2^{n-1}} \right)$$

$$= 1 + \frac{2}{2} + \frac{4}{4} + \frac{8}{8} + \dots + \frac{2^{n-1}}{2^{n-1}}$$

$$= \underbrace{1 + 1 + 1 + 1 + \dots + 1}_{(n) \text{ times}} = n$$

Thus, $a(100) \leq 100$

Therefore, (a) is the answer.

Again, $a(n) = 1 + \frac{1}{2} + \left(\frac{1}{3} + \frac{1}{4} \right) + \left(\frac{1}{5} + \dots + \frac{1}{8} \right)$

$$+ \dots + \left(\frac{1}{2^{n-1} + 1} + \dots + \frac{1}{2^n} \right) - \frac{1}{2^n}$$

$$> 1 + \frac{1}{2} + \left(\frac{1}{4} + \frac{1}{4} \right) + \left(\frac{1}{8} + \frac{1}{8} + \dots + \frac{1}{8} \right)$$

$$+ \dots + \left(\frac{1}{2^n} + \dots + \frac{1}{2^n} \right) - \frac{1}{2^n}$$

$$= 1 + \frac{1}{2} + \frac{2}{4} + \frac{4}{8} + \dots + \frac{2^{n-1}}{2^n} - \frac{1}{2^n}$$

$$= 1 + \frac{1}{2} + \frac{1}{2} + \frac{1}{2} + \dots + \frac{1}{2} - \frac{1}{2^n} = \left(1 - \frac{1}{2^n} \right) + \frac{n}{2}$$

Therefore, $a(200) > \left(1 - \frac{1}{2^{200}} \right) + \frac{200}{2} > 100$

Therefore, (d) is also the answer.

24. Since, first and $(2n - 1)$ th terms are equal.

Let first term be x and $(2n - 1)$ th term be y , whose middle term is t_n .

Thus, in arithmetic progression, $t_n = \frac{x+y}{2} = a$

In geometric progression, $t_n = \sqrt{xy} = b$

In harmonic progression, $t_n = \frac{2xy}{x+y} = c$

$$\Rightarrow b^2 = ac \text{ and } a > b > c \quad [\text{using AM} > \text{GM} > \text{HM}]$$

Here, equality holds (i.e. $a = b = c$) only if all terms are same. Hence, options (a), (b) and (d) are correct.

25. Let the two positive numbers be a and b .

$$\therefore x = \frac{a+b}{2} \quad [\text{since, } x \text{ is AM between } a \text{ and } b] \quad \dots (i)$$

and $\frac{a}{y} = \frac{y}{z} = \frac{z}{b}$ [since, y, z are GM's between a and b]

$$\therefore a = \frac{y^2}{z} \text{ and } b = \frac{z^2}{y}$$

On substituting the values of a and b in Eq. (i), we get

$$2x = \frac{y^2}{z} + \frac{z^2}{y} \Rightarrow \frac{y^3 + z^3}{yz} = 2x \Rightarrow \frac{y^3 + z^3}{xyz} = 2$$

26. Let the two positive numbers be ka and $a, a > 0$.

Then, $G = \sqrt{ka \cdot a} = \sqrt{k} \cdot a$ and $H = \frac{2(ka)a}{ka+a} = \frac{2ka}{k+1}$

Again, $\frac{H}{G} = \frac{4}{5}$ [given]

$$\Rightarrow \frac{\frac{2ka}{k+1}}{\sqrt{k}a} = \frac{4}{5} \Rightarrow \frac{2\sqrt{k}}{k+1} = \frac{4}{5}$$

$$\Rightarrow 5\sqrt{k} = 2k + 2 \Rightarrow 2k - 5\sqrt{k} + 2 = 0$$

$$\Rightarrow \sqrt{k} = \frac{5 \pm \sqrt{25 - 16}}{4} = \frac{5 \pm 3}{4} = 2, \frac{1}{2} \Rightarrow k = 4, 1/4.$$

Hence, the required ratio is 4 : 1.

74 Sequences and Series

27. Using AM \geq GM,

$$\frac{1+x^{2n}}{2} \geq \sqrt{1 \cdot x^{2n}} \Rightarrow \frac{1+x^{2n}}{2} \geq x^n$$

$$\Rightarrow \frac{x^n}{1+x^{2n}} \leq \frac{1}{2} \Rightarrow \frac{x^n \cdot y^n}{(1+x^{2n})(1+y^{2m})} \leq \frac{1}{4}$$

Hence, it is false statement.

28. Since, $\frac{\log_a x + \frac{1}{\log_a x}}{2} > 1$, using AM $>$ GM

Here, equality holds only when $x=a$ which is not possible. So, $\log_a x + \log_x a$ is greater than 2.

Hence, it is a false statement.

29. Here, $(1+a)(1+b)(1+c)$

$$= 1 + a + b + c + ab + bc + ca + abc \quad \dots(i)$$

$$\text{Since, } \frac{a+b+c+ab+bc+ca+abc}{7} \geq (a^4 b^4 c^4)^{1/7}$$

[using AM \geq GM]

$$\Rightarrow a + b + c + ab + bc + ca + abc \geq 7(a^4 b^4 c^4)^{1/7}$$

$$\Rightarrow 1 + a + b + c + ca + abc > 7(a^4 b^4 c^4)^{1/7} \quad \dots(ii)$$

From Eqs. (i) and (ii), we get

$$(1+a)(1+b)(1+c) > 7(a^4 b^4 c^4)^{1/7}$$

$$\text{or } \{(1+a)(1+b)(1+c)\}^7 > 7^7 (a^4 b^4 c^4)$$

30. Let G_m be the geometric mean of G_1, G_2, \dots, G_n .

$$\Rightarrow G_m = (G_1 \cdot G_2 \dots G_n)^{1/n}$$

$$= [(a_1) \cdot (a_1 \cdot a_1 r)^{1/2} \cdot (a_1 \cdot a_1 r \cdot a_1 r^2)^{1/3} \dots (a_1 \cdot a_1 r \cdot a_1 r^2 \dots a_1 r^{n-1})^{1/n}]^{1/n}$$

where, r is the common ratio of GP a_1, a_2, \dots, a_n .

$$= [(a_1 \cdot a_1 \dots n \text{ times}) (r^{1/2} \cdot r^{3/3} \cdot r^{6/4} \dots r^{2n})]^{1/n}$$

$$= [a_1^n \cdot r^{2+1+\frac{3}{2}+\dots+\frac{n-1}{2}}]^{1/n}$$

$$= a_1 \left[r^{\frac{1}{2} \left[\frac{(n-1)n}{2} \right]} \right]^{1/n} = a_1 \left[r^{\frac{n-1}{4}} \right] \quad \dots(i)$$

$$\text{Now, } A_n = \frac{a_1 + a_2 + \dots + a_n}{n} = \frac{a_1(1-r^n)}{n(1-r)}$$

$$\text{and } H_n = \frac{n}{\left(\frac{1}{a_1} + \frac{1}{a_2} + \dots + \frac{1}{a_n} \right)}$$

$$= \frac{n}{\frac{1}{a_1} \left(1 + \frac{1}{r} + \dots + \frac{1}{r^{n-1}} \right)} = \frac{a_1 n (1-r) r^{n-1}}{1-r^n}$$

$$\therefore A_n \cdot H_n = \frac{a_1(1-r^n)}{n(1-r)} \times \frac{a_1 n (1-r) r^{n-1}}{(1-r^n)} = a_1^2 r^{n-1}$$

$$\Rightarrow \prod_{k=1}^n A_k H_k = \prod_{k=1}^n (a_1^2 r^{n-1})$$

$$= (a_1^2 \cdot a_1^2 \cdot a_1^2 \dots n \text{ times}) \times r^0 \cdot r^1 \cdot r^2 \dots r^{n-1}$$

$$= a_1^{2n} \cdot r^{1+2+\dots+(n-1)} = a_1^{2n} r^{\frac{n(n-1)}{2}} = [a_1 r^{\frac{n-1}{4}}]^{2n}$$

$$= [G_m]^{2n} \quad \text{[from Eq. (i)]}$$

$$G_m = \left[\prod_{k=1}^n A_k H_k \right]^{1/2n}$$

$$\Rightarrow G_m = (A_1 A_2 \dots A_n H_1 H_2 \dots H_n)^{1/2n}$$

31. Let two numbers be a and b and A_1, A_2, \dots, A_n be n arithmetic means between a and b . Then, $a, A_1, A_2, \dots, A_n, b$ are in AP with common difference

$$d = \frac{b-a}{n+1} \Rightarrow p = A_1 = a + d = a + \frac{b-a}{n+1}$$

$$\Rightarrow p = \frac{na+b}{n+1} \quad \dots(i)$$

Let H_1, H_2, \dots, H_n be n harmonic means between a and b .

$\therefore \frac{1}{a}, \frac{1}{H_1}, \frac{1}{H_2}, \dots, \frac{1}{H_n}, \frac{1}{b}$ is an AP with common difference, $D = \frac{(a-b)}{(n+1)ab}$.

$$\therefore \frac{1}{q} = \frac{1}{a} + D \Rightarrow \frac{1}{q} = \frac{1}{a} + \frac{(a-b)}{(n+1)ab}$$

$$\Rightarrow \frac{1}{q} = \frac{nb+a}{(n+1)ab} \Rightarrow q = \frac{(n+1)ab}{nb+a} \quad \dots(ii)$$

From Eq. (i), $b = (n+1)p - na$.

Putting it in Eq. (ii), we get

$$q \{ n(n+1)p - n^2 a + a \} = (n+1)a \{ (n+1)p - na \}$$

$$\Rightarrow n(n+1)a^2 - \{ (n+1)^2 p + (n^2-1)q \} a + n(n+1)pq = 0$$

$$\Rightarrow na^2 - \{ (n+1)p + (n-1)q \} a + npq = 0$$

Since, a is real, therefore

$$\{ (n+1)p + (n-1)q \}^2 - 4n^2 pq > 0$$

$$\Rightarrow (n+1)^2 p^2 + (n-1)^2 q^2 + 2(n^2-1)pq - 4n^2 pq > 0$$

$$\Rightarrow (n+1)^2 p^2 + (n-1)^2 q^2 - 2(n^2+1)pq > 0$$

$$\Rightarrow q^2 - \frac{2(n^2+1)}{(n-1)^2} pq + \left(\frac{n+1}{n-1} \right)^2 p^2 > 0$$

$$\Rightarrow q^2 - \left\{ 1 + \left(\frac{n+1}{n-1} \right)^2 \right\} pq + \left(\frac{n+1}{n-1} \right)^2 p^2 > 0$$

$$\Rightarrow (q-p) \left\{ q - \left(\frac{n+1}{n-1} \right)^2 p \right\} > 0$$

$$\Rightarrow q < p \text{ or } q > \left(\frac{n+1}{n-1} \right)^2 p$$

$$\therefore \left\{ \left(\frac{n+1}{n-1} \right)^2 p > p \right\}$$

Hence, q cannot lie between p and $\left(\frac{n+1}{n-1} \right)^2 p$.

32. Since $a, b, c > 0$

$$\Rightarrow \frac{(a+b+c)}{3} > (abc)^{1/3} \quad \dots(i)$$

[using AM \geq GM]

Also,
$$\frac{\frac{1}{a} + \frac{1}{b} + \frac{1}{c}}{3} \geq \left(\frac{1}{a} \cdot \frac{1}{b} \cdot \frac{1}{c}\right)^{1/3} \quad \dots(ii)$$

[using AM \geq GM]

On multiplying Eqs. (i) and (ii), we get

$$\frac{(a+b+c)\left(\frac{1}{a} + \frac{1}{b} + \frac{1}{c}\right)}{9} \geq (abc)^{1/3} \cdot \frac{1}{(abc)^{1/3}}$$

$$\therefore (a+b+c)\left(\frac{1}{a} + \frac{1}{b} + \frac{1}{c}\right) \geq 9$$

33. For real numbers y_1, y_2, y_3 , the quantities $3^{y_1}, 3^{y_2}$ and 3^{y_3} are positive real numbers, so according to the AM-GM inequality, we have

$$\frac{3^{y_1} + 3^{y_2} + 3^{y_3}}{3} \geq (3^{y_1} \cdot 3^{y_2} \cdot 3^{y_3})^{1/3}$$

$$\Rightarrow 3^{y_1} + 3^{y_2} + 3^{y_3} \geq 3(3^{y_1} \cdot 3^{y_2} \cdot 3^{y_3})^{1/3}$$

On applying logarithm with base '3', we get

$$\log_3(3^{y_1} + 3^{y_2} + 3^{y_3}) \geq \left[1 + \frac{1}{3}(y_1 + y_2 + y_3)\right]$$

$$= 1 + 3$$

$$= 4 \quad \{\because y_1 + y_2 + y_3 = 9\}$$

$$\therefore m = 4$$

Now, for positive real numbers x_1, x_2 and x_3 , according to AM-GM inequality, we have

$$\frac{x_1 + x_2 + x_3}{3} \geq (x_1 x_2 x_3)^{1/3}$$

On applying logarithm with base '3', we get

$$\log_3\left(\frac{x_1 + x_2 + x_3}{3}\right) \geq \frac{1}{3}(\log_3 x_1 + \log_3 x_2 + \log_3 x_3)$$

$$\Rightarrow 1 \geq \frac{1}{3}(\log_3 x_1 + \log_3 x_2 + \log_3 x_3)$$

$$\{\because x_1 + x_2 + x_3 = 9\}$$

$$\therefore M = 3$$

$$\text{Now, } \log_2(m^3) + \log_3(M^2) = 3 \log_2(4) + 2 \log_3(3)$$

$$= 6 + 2 = 8$$

34. Given arithmetic progression of positive integers terms a_1, a_2, a_3, \dots having common difference '2' and geometric progression of positive integers terms b_1, b_2, b_3, \dots having common ratio '2' with $a_1 = b_1 = c$, such that

$$2(a_1 + a_2 + a_3 + \dots + a_n) = b_1 + b_2 + b_3 + \dots + b_n$$

$$\Rightarrow 2 \times \frac{n}{2} [2C + (n-1)2] = C \left(\frac{2^n - 1}{2 - 1}\right)$$

$$\Rightarrow 2nC + 2n^2 - 2n = 2^n \cdot C - C$$

$$\Rightarrow C[2^n - 2n - 1] = 2n^2 - 2n$$

$$\therefore C \in N \Rightarrow 2n^2 - 2n \geq 2^n - 2n - 1$$

$$\Rightarrow 2n^2 + 1 \geq 2^n \Rightarrow n \leq 6$$

$$\text{and, also } C > 0 \Rightarrow n > 2$$

\therefore The possible values of n are 3, 4, 5, 6

$$\text{So, at } n = 3, C = \frac{(2 \times 9) - 6}{8 - 6 - 1} = 12$$

$$\text{at, } n = 4, C = \frac{32 - 8}{16 - 8 - 1} = \frac{24}{9} = \frac{8}{3} \notin N$$

$$\text{at, } n = 5, C = \frac{50 - 10}{32 - 10 - 1} = \frac{40}{21} \notin N$$

$$\text{and at, } n = 6, C = \frac{72 - 12}{64 - 12 - 1} = \frac{60}{51} \notin N$$

\therefore The required value of $C = 12$ for $n = 3$.

35. The 4th AM out of m AMs inserted between 3 and 243 is

$$A_4 = 3 + 4 \frac{243 - 3}{m + 1} \quad \dots(i)$$

and the 2nd GM out of three GMs inserted between 3 and 243 is

$$G_2 = 3 \left(\left(\frac{243}{3} \right)^{\frac{1}{3+1}} \right)^2 = 3(81)^{1/2} = 27$$

$$\therefore A_4 = G_2 \Rightarrow 3 + 4 \left(\frac{240}{m + 1} \right) = 27$$

$$\Rightarrow 4 \left(\frac{240}{m + 1} \right) = 24 \Rightarrow m + 1 = 40 \Rightarrow m = 39$$

Hence, answer is 39.00

36. Plan

(i) If a, b, c are in GP, then they can be taken as a, ar, ar^2 where $r, (r \neq 0)$ is the common ratio.

(ii) Arithmetic mean of $x_1, x_2, \dots, x_n = \frac{x_1 + x_2 + \dots + x_n}{n}$

Let a, b, c be a, ar, ar^2 , where $r \in N$

$$\text{Also, } \frac{a + b + c}{3} = b + 2$$

$$\Rightarrow a + ar + ar^2 = 3(ar) + 6$$

$$\Rightarrow ar^2 - 2ar + a = 6$$

$$\Rightarrow (r - 1)^2 = \frac{6}{a}$$

Since, $6/a$ must be perfect square and $a \in N$.

So, a can be 6 only.

$$\Rightarrow r - 1 = \pm 1 \Rightarrow r = 2$$

$$\text{and } \frac{a^2 + a - 14}{a + 1} = \frac{36 + 6 - 14}{7} = 4$$

37. Using AM \geq GM,

$$\frac{a^{-5} + a^{-4} + a^{-3} + a^{-3} + a^{-3} + 1 + a^8 + a^{10}}{8}$$

$$\geq (a^{-5} \cdot a^{-4} \cdot a^{-3} \cdot a^{-3} \cdot a^{-3} \cdot 1 \cdot a^8 \cdot a^{10})^{1/8}$$

$$\Rightarrow a^{-5} + a^{-4} + 3a^{-3} + 1 + a^8 + a^{10} \geq 8 \cdot 1$$

Hence, minimum value is 8.

4

Permutations and Combinations

Topic 1 General Arrangement

Objective Questions I (Only one correct option)

- The number of four-digit numbers strictly greater than 4321 that can be formed using the digits 0, 1, 2, 3, 4, 5 (repetition of digits is allowed) is (2019 Main, 8 April II)
(a) 306 (b) 310
(c) 360 (d) 288
- How many 3×3 matrices M with entries from $\{0, 1, 2\}$ are there, for which the sum of the diagonal entries of $M^T M$ is 5? (2017 Adv.)
(a) 198 (b) 162 (c) 126 (d) 135
- The number of integers greater than 6000 that can be formed using the digits 3, 5, 6, 7 and 8 without repetition is (2015 Main)
(a) 216 (b) 192
(c) 120 (d) 72
- The number of seven-digit integers, with sum of the digits equal to 10 and formed by using the digits 1, 2 and 3 only, is (2009)
(a) 55 (b) 66 (c) 77 (d) 88
- How many different nine-digit numbers can be formed from the number 22 33 55 888 by rearranging its digits so that the odd digits occupy even positions? (2000, 2M)
(a) 16 (b) 36
(c) 60 (d) 180
- An n -digit number is a positive number with exactly n digits. Nine hundred distinct n -digit numbers are to be formed using only the three digits 2, 5 and 7. The smallest value of n for which this is possible, is (1998, 2M)
(a) 6 (b) 7 (c) 8 (d) 9
- In a collage of 300 students, every student reads 5 newspapers and every newspaper is read by 60 students. The number of newspapers is (1998, 2M)
(a) atleast 30
(b) atmost 20
(c) exactly 25
(d) None of the above
- A five digits number divisible by 3 is to be formed using the numbers 0, 1, 2, 3, 4 and 5, without repetition. The total number of ways this can be done, is (1989, 2M)
(a) 216 (b) 240
(c) 600 (d) 3125
- Eight chairs are numbered 1 to 8. Two women and three men wish to occupy one chair each. First the women choose the chairs from amongst the chairs marked 1 to 4 and then the men select the chairs from amongst the remaining. The number of possible arrangements is
(a) ${}^6C_3 \times {}^4C_2$ (b) ${}^4P_2 \times {}^4P_3$ (1982, 2M)
(c) ${}^4C_2 + {}^4P_3$ (d) None of these
- The different letters of an alphabet are given. Words with five letters are formed from these given letters. Then, the number of words which have at least one letter repeated, is (1980, 2M)
(a) 69760 (b) 30240
(c) 99748 (d) None

Analytical & Descriptive Question

- Eighteen guests have to be seated half on each side of a long table. Four particular guests desire to sit on one particular side and three other on the other side. Determine the number of ways in which the sitting arrangements can be made. (1991, 4M)

Match the Columns

Match the conditions/expressions in Column I with statement in Column II.

12. Consider all possible permutations of the letters of the word ENDEANOEL.

(2008, 6M)

Column I	Column II
A. The number of permutations containing the word ENDEA, is	p. $5!$
B. The number of permutations in which the letter E occurs in the first and the last positions, is	q. $2 \times 5!$
C. The number of permutations in which none of the letters D, L, N occurs in the last five positions, is	r. $7 \times 5!$
D. The number of permutations in which the letters A, E, O occur only in odd positions, is	s. $21 \times 5!$

Topic 2 Properties of Combinational and General Selections

Objective Questions I (Only one correct option)

- There are 3 sections in a question paper and each section contains 5 questions. A candidate has to answer a total of 5 questions, choosing at least one question from each section. Then the number of ways, in which the candidate can choose the questions, is
(2020 Main, 5 Sep II)
(a) 3000 (b) 1500
(c) 2255 (d) 2250
- The number of ways of choosing 10 objects out of 31 objects of which 10 are identical and the remaining 21 are distinct, is
(2019 Main, 12 April I)
(a) $2^{20} - 1$ (b) 2^{21} (c) 2^{20} (d) $2^{20} + 1$
- Suppose that 20 pillars of the same height have been erected along the boundary of a circular stadium. If the top of each pillar has been connected by beams with the top of all its non-adjacent pillars, then the total number of beams is
(2019 Main, 10 April II)
(a) 180 (b) 210 (c) 170 (d) 190
- Some identical balls are arranged in rows to form an equilateral triangle. The first row consists of one ball, the second row consists of two balls and so on. If 99 more identical balls are added to the total number of balls used in forming the equilateral triangle, then all these balls can be arranged in a square whose each side contains exactly 2 balls less than the number of balls each side of the triangle contains. Then, the number of balls used to form the equilateral triangle is
(2019 Main, 9 April II)
(a) 262 (b) 190 (c) 225 (d) 157
- There are m men and two women participating in a chess tournament. Each participant plays two games with every other participant. If the number of games played by the men between themselves exceeds the number of games played between the men and the women by 84, then the value of m is (2019 Main, 12 Jan II)
(a) 12 (b) 11 (c) 9 (d) 7

- If ${}^n C_4$, ${}^n C_5$ and ${}^n C_6$ are in AP, then n can be
(2019 Main, 12 Jan II)
(a) 9 (b) 11 (c) 14 (d) 12
- If $\sum_{r=0}^{25} \{ {}^{50} C_r \cdot {}^{50-r} C_{25-r} \} = K ({}^{50} C_{25})$, then, K is equal to
(2019 Main, 10 Jan II)
(a) 2^{24} (b) $2^{25} - 1$ (c) 2^{25} (d) $(25)^2$
- If $\sum_{i=1}^{20} \left(\frac{{}^{20} C_{i-1}}{{}^{20} C_i + {}^{20} C_{i-1}} \right)^3 = \frac{k}{21}$, then k equals
(2019 Main, 10 Jan I)
(a) 100 (b) 400 (c) 200 (d) 50
- A man X has 7 friends, 4 of them are ladies and 3 are men. His wife Y also has 7 friends, 3 of them are ladies and 4 are men. Assume X and Y have no common friends. Then, the total number of ways in which X and Y together can throw a party inviting 3 ladies and 3 men, so that 3 friends of each of X and Y are in this party, is
(2017 Main)
(a) 485 (b) 468 (c) 469 (d) 484
- Let $S = \{1, 2, 3, \dots, 9\}$. For $k = 1, 2, \dots, 5$, let N_k be the number of subsets of S , each containing five elements out of which exactly k are odd. Then $N_1 + N_2 + N_3 + N_4 + N_5 =$
(2017 Adv.)
(a) 210 (b) 252 (c) 126 (d) 125
- A debate club consists of 6 girls and 4 boys. A team of 4 members is to be selected from this club including the selection of a captain (from among these 4 members) for the team. If the team has to include atmost one boy, the number of ways of selecting the team is
(2016 Adv.)
(a) 380 (b) 320 (c) 260 (d) 95
- Let T_n be the number of all possible triangles formed by joining vertices of an n -sided regular polygon. If $T_{n+1} - T_n = 10$, then the value of n is
(2013 Main)
(a) 7 (b) 5
(c) 10 (d) 8

78 Permutations and Combinations

13. If r, s, t are prime numbers and p, q are the positive integers such that LCM of p, q is $r^2s^4t^2$, then the number of ordered pairs (p, q) is (2006, 3M)
- (a) 252 (b) 254
(c) 225 (d) 224
14. The value of the expression ${}^{47}C_4 + \sum_{j=1}^5 {}^{52-j}C_3$ is (1980, 2M)
- (a) ${}^{47}C_5$
(b) ${}^{52}C_5$
(c) ${}^{52}C_4$
(d) None of these

Match the Columns

15. In a high school, a committee has to be formed from a group of 6 boys $M_1, M_2, M_3, M_4, M_5, M_6$ and 5 girls G_1, G_2, G_3, G_4, G_5 .
- (i) Let α_1 be the total number of ways in which the committee can be formed such that the committee has 5 members, having exactly 3 boys and 2 girls.
- (ii) Let α_2 be the total number of ways in which the committee can be formed such that the committee has at least 2 members, and having an equal number of boys and girls.
- (iii) Let α_3 be the total number of ways in which the committee can be formed such that the committee has 5 members, at least 2 of them being girls.
- (iv) Let α_4 be the total number of ways in which the committee can be formed such that the committee has 4 members, having at least 2 girls such that both M_1 and G_1 are NOT in the committee together. (2018 Adv.)

	List-I	List-II
P.	The value of α_1 is	1. 136
Q.	The value of α_2 is	2. 189
R.	The value of α_3 is	3. 192
S.	The value of α_4 is	4. 200
		5. 381
		6. 461

The correct option is

- (a) $P \rightarrow 4; Q \rightarrow 6; R \rightarrow 2; S \rightarrow 1$
(b) $P \rightarrow 1; Q \rightarrow 4; R \rightarrow 2; S \rightarrow 3$
(c) $P \rightarrow 4; Q \rightarrow 6; R \rightarrow 5; S \rightarrow 2$
(d) $P \rightarrow 4; Q \rightarrow 2; R \rightarrow 3; S \rightarrow 1$

Integer & Numerical Answer Type Questions

16. Five persons A, B, C, D and E are seated in a circular arrangement. If each of them is given a hat of one of the three colours red, blue and green, then the number of ways of distributing the hats such that the persons seated in adjacent seats get different coloured hats is (2019 Adv.)

17. Let $n \geq 2$ be an integer. Take n distinct points on a circle and join each pair of points by a line segment. Colour the line segment joining every pair of adjacent points by blue and the rest by red. If the number of red and blue line segments are equal, then the value of n is (2014 Adv.)

Fill in the Blanks

18. Let A be a set of n distinct elements. Then, the total number of distinct functions from A to A is...and out of these... are onto functions. (1985, 2M)
19. In a certain test, a_i students gave wrong answers to at least i questions, where $i = 1, 2, \dots, k$. No student gave more than k wrong answers. The total number of wrong answers given is (1982, 2M)

True/False

20. The product of any r consecutive natural numbers is always divisible by $r!$. (1985, 1M)

Analytical & Descriptive Questions

21. A committee of 12 is to be formed from 9 women and 8 men. In how many ways this can be done if at least five women have to be included in a committee? In how many of these committees
(i) the women are in majority?
(ii) the men are in majority? (1994, 4M)
22. A student is allowed to select at most n books from n collection of $(2n + 1)$ books. If the total number of ways in which he can select at least one books is 63, find the value of n . (1987, 3M)
23. A box contains two white balls, three black balls and four red balls. In how many ways can three balls be drawn from the box, if at least one black ball is to be included in the draw? (1986, 2½ M)
24. 7 relatives of a man comprises 4 ladies and 3 gentlemen, his wife has also 7 relatives; 3 of them are ladies and 4 gentlemen. In how many ways can they invite a dinner party of 3 ladies and 3 gentlemen so that there are 3 of man's relative and 3 of the wife's relatives? (1985, 5M)
25. m men and n women are to be seated in a row so that no two women sit together. If $m > n$, then show that the number of ways in which they can be seated, is
$$\frac{m!(m+1)!}{(m-n+1)!}$$
 (1983, 2M)
26. mn squares of equal size are arranged to form a rectangle of dimension m by n where m and n are natural numbers. Two squares will be called 'neighbours' if they have exactly one common side. A natural number is written in each square such that the number in written any square is the arithmetic mean of the numbers written in its neighbouring squares. Show that this is possible only if all the numbers used are equal. (1982, 5M)
27. If ${}^nC_{r-1} = 36$, ${}^nC_r = 84$ and ${}^nC_{r+1} = 126$, then find the values of n and r . (1979, 3M)

Topic 3 Multinomial, Repeated Arrangement and Selection

Objective Question I (Only one correct option)

- The number of 6 digits numbers that can be formed using the digits 0, 1, 2, 5, 7 and 9 which are divisible by 11 and no digit is repeated, is (2019 Main, 10 April I)

(a) 60	(b) 72
(c) 48	(d) 36
- A committee of 11 members is to be formed from 8 males and 5 females. If m is the number of ways the committee is formed with at least 6 males and n is the number of ways the committee is formed with at least 3 females, then (2019 Main, 9 April I)

(a) $m = n = 68$	(b) $m + n = 68$
(c) $m = n = 78$	(d) $n = m - 8$
- Consider three boxes, each containing 10 balls labelled 1, 2, ..., 10. Suppose one ball is randomly drawn from each of the boxes. Denote by n_i , the label of the ball drawn from the i th box, ($i = 1, 2, 3$). Then, the number of ways in which the balls can be chosen such that $n_1 < n_2 < n_3$ is (2019 Main, 12 Jan I)

(a) 82	(b) 120
(c) 240	(d) 164
- The number of natural numbers less than 7,000 which can be formed by using the digits 0, 1, 3, 7, 9 (repetition of digits allowed) is equal to (2019 Main, 9 Jan II)

(a) 374	(b) 375
(c) 372	(d) 250
- Consider a class of 5 girls and 7 boys. The number of different teams consisting of 2 girls and 3 boys that can be formed from this class, if there are two specific boys A and B , who refuse to be the members of the same team, is (2019 Main, 9 Jan I)

(a) 350	(b) 500
(c) 200	(d) 300
- If all the words (with or without meaning) having five letters, formed using the letters of the word SMALL and arranged as in a dictionary, then the position of the word SMALL is (2016 Main)

(a) 46th	(b) 59th
(c) 52nd	(d) 58th
- The letters of the word COCHIN are permuted and all the permutations are arranged in an alphabetical order as in an English dictionary. The number of words that appear before the word COCHIN, is (2007, 3M)

(a) 360	(b) 192
(c) 96	(d) 48

Integer & Numerical Answer Type Questions

- An engineer is required to visit a factory for exactly four days during the first 15 days of every month and it is mandatory that no two visits take place on consecutive days. Then the number of all possible ways in which such visits to the factory can be made by the engineer during 1-15 June 2021 is (2020 Adv.)
- If the letters of the word 'MOTHER' be permuted and all the words so formed (with or without meaning) be listed as in dictionary, then the position of the word 'MOTHER' is..... (2020 Main, 2 Sep I)
- The number of 5 digit numbers which are divisible by 4, with digits from the set $\{1, 2, 3, 4, 5\}$ and the repetition of digits is allowed, is (2018 Adv.)
- Words of length 10 are formed using the letters A, B, C, D, E, F, G, H, I, J. Let x be the number of such words where no letter is repeated; and let y be the number of such words where exactly one letter is repeated twice and no other letter is repeated. Then, $\frac{y}{9x} =$ (2017 Adv.)
- Let n be the number of ways in which 5 boys and 5 girls can stand in a queue in such a way that all the girls stand consecutively in the queue. Let m be the number of ways in which 5 boys and 5 girls can stand in a queue in such a way that exactly four girls stand consecutively in the queue. Then, the value of $\frac{m}{n}$ is (2015 Adv.)
- Let $n_1 < n_2 < n_3 < n_4 < n_5$ be positive integers such that $n_1 + n_2 + n_3 + n_4 + n_5 = 20$. The number of such distinct arrangements $(n_1, n_2, n_3, n_4, n_5)$ is (2014 Adv.)

Fill in the Blanks

- Let n and k be positive integers such that $n \geq \frac{k(k+1)}{2}$.
The number of solutions (x_1, x_2, \dots, x_k) , $x_1 \geq 1, x_2 \geq 2, \dots, x_k \geq k$ for all integers satisfying $x_1 + x_2 + \dots + x_k = n$ is ... (1996, 2M)
- Total number of ways in which six '+' and four '-' signs can be arranged in a line such that no two '-' signs occur together is... (1988, 2M)

Analytical & Descriptive Question

- Five balls of different colours are to be placed in three boxes of different sizes. Each box can hold all five. In how many different ways can we place the balls so that no box remains empty? (1981, 4M)

Topic 4 Distribution of Object into Group

Objective Questions I (Only one correct option)

- A group of students comprises of 5 boys and n girls. If the number of ways, in which a team of 3 students can randomly be selected from this group such that there is at least one boy and at least one girl in each team, is 1750, then n is equal to (2019 Main, 12 April II)
 (a) 28 (b) 27
 (c) 25 (d) 24
- Let S be the set of all triangles in the xy -plane, each having one vertex at the origin and the other two vertices lie on coordinate axes with integral coordinates. If each triangle in S has area 50 sq. units, then the number of elements in the set S is (2019 Main, 9 Jan II)
 (a) 36 (b) 32
 (c) 18 (d) 9
- From 6 different novels and 3 different dictionaries, 4 novels and 1 dictionary are to be selected and arranged in a row on a shelf, so that the dictionary is always in the middle. The number of such arrangements is (2018 Main)
 (a) at least 1000
 (b) less than 500
 (c) at least 500 but less than 750
 (d) at least 750 but less than 1000

- The total number of ways in which 5 balls of different colours can be distributed among 3 persons so that each person gets at least one ball, is (2012)
 (a) 75 (b) 150 (c) 210 (d) 243
- The number of arrangements of the letters of the word BANANA in which the two N's do not appear adjacently, is (2002, 1M)
 (a) 40 (b) 60 (c) 80 (d) 100

Analytical & Descriptive Questions

- Using permutation or otherwise, prove that $\frac{n^2!}{(n!)^n}$ is an integer, where n is a positive integer. (2004, 2M)
- In how many ways can a pack of 52 cards be
 (i) divided equally among four players in order
 (ii) divided into four groups of 13 cards each
 (iii) divided in 4 sets, three of them having 17 cards each and the fourth just one card? (1979, 3M)

Integer & Numerical Answer Type Question

- In a hotel, four rooms are available. Six persons are to be accommodated in these four rooms in such a way that each of these rooms contains at least one person and at most two persons. Then the number of all possible ways in which this can be done is (2020 Adv.)

Topic 5 Dearrangement and Number of Divisors

Objective Question I (Only one correct option)

- Number of divisors of the form $(4n + 2)$, $n \geq 0$ of the integer 240 is (1998, 2M)
 (a) 4 (b) 8
 (c) 10 (d) 3

Fill in the Blank

- There are four balls of different colours and four boxes of colours, same as those of the balls. The number of ways in which the balls, one each in a box, could be placed such that a ball does not go to a box of its own colour is.... (1992, 2M)

Answers

Topic 1

- (b) 2. (a) 3. (b) 4. (c)
- (c) 6. (b) 7. (c) 8. (a)
- (d) 10. (a) 11. ${}^9P_4 \times {}^9P_3$ (11)!
- (A \rightarrow p; B \rightarrow s; C \rightarrow q; D \rightarrow q)

Topic 2

- (d) 2. (c) 3. (c) 4. (b)
- (a) 6. (c) 7. (c) 8. (a)
- (a) 10. (c) 11. (a) 12. (b)
- (c) 14. (c) 15. (c) 16. (30)
- (5) 18. $n^n, \sum_{r=1}^n (-1)^{n-r} {}^nC_r (r)^n$ 19. $2^n - 1$
- (True)
- 6062, (i) 2702 (ii) 1008 22. $n = 3$
- (64) 24. (485) 27. ($n = 9$ and $r = 3$)

Topic 3

- (a) 2. (c) 3. (b) 4. (a)
- (d) 6. (d) 7. (c) 8. (495)
- (309) 10. (625) 11. (5) 12. (5)
- (7) 14. $\frac{1}{2}(2n - k^2 + k - 2)$ 15. (35 ways)
- (300)

Topic 4

- (c) 2. (a) 3. (a) 4. (b)
- (a) 7. (i) $\frac{(52)!}{(13!)^4}$ (ii) $\frac{(52)!}{4!(13!)^4}$ (iii) $\frac{(52)!}{3!(17)^3}$
- (1080)

Topic 5

- (a) 2. (9)

Hints & Solutions

Topic 1 General Arrangement

1. Following are the cases in which the 4-digit numbers strictly greater than 4321 can be formed using digits 0, 1, 2, 3, 4, 5 (repetition of digits is allowed)

Case-I

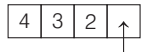

$2/3/4/5 \rightarrow 4$ ways 4 numbers

Case-II

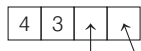

$3/4/5$ $0/1/2/3/4/5$ $3 \times 6 = 18$ numbers
3 ways 6 ways

Case-III

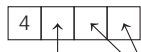

$4/5$ $0/1/2/3/4/5$ $2 \times 6 \times 6 = 72$ numbers
2 ways 6 ways

Case-IV

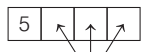

$0/1/2/3/4/5$ $6 \times 6 \times 6 = 216$ numbers
6 ways

So, required total numbers = $4 + 18 + 72 + 216 = 310$

2. Sum of diagonal entries of $M^T M$ is $\sum a_i^2$.

$$\sum_{i=1}^9 a_i^2 = 5$$

Possibilities

- I. 2, 1, 0, 0, 0, 0, 0, 0, 0, which gives $\frac{9!}{7!}$ matrices
II. 1, 1, 1, 1, 1, 0, 0, 0, 0, 0, which gives $\frac{9!}{4! \times 5!}$ matrices

Total matrices = $9 \times 8 + 9 \times 7 \times 2 = 198$

3. The integer greater than 6000 may be of 4 digits or 5 digits. So, here two cases arise.

Case I When number is of 4 digits.

Four-digit number can start from 6, 7 or 8.

Thus, total number of 4-digit numbers, which are greater than 6000 = $3 \times 4 \times 3 \times 2 = 72$

Case II When number is of 5 digits.

Total number of five-digit numbers which are greater than 6000 = $5! = 120$

\therefore Total number of integers = $72 + 120 = 192$

4. There are two possible cases

Case I Five 1's, one 2's, one 3's

Number of numbers = $\frac{7!}{5!} = 42$

Case II Four 1's, three 2's

Number of numbers = $\frac{7!}{4!3!} = 35$

\therefore Total number of numbers = $42 + 35 = 77$

5. $X-X-X-X-X$. The four digits 3, 3, 5, 5 can be arranged at (—) places in $\frac{4!}{2!2!} = 6$ ways.

The five digits 2, 2, 8, 8, 8 can be arranged at (X) places in $\frac{5!}{2!3!}$ ways = 10 ways.

Total number of arrangements = $6 \times 10 = 60$

[since, events A and B are independent, therefore $A \cap B = A \times B$]

6. Distinct n -digit numbers which can be formed using digits 2, 5 and 7 are 3^n . We have to find n , so that

$$3^n \geq 900$$

$$\Rightarrow 3^{n-2} \geq 100$$

$$\Rightarrow n - 2 \geq 5$$

$$\Rightarrow n \geq 7, \text{ so the least value of } n \text{ is } 7.$$

7. Let n be the number of newspapers which are read by the students.

$$\text{Then, } 60n = (300) \times 5$$

$$\Rightarrow n = 25$$

8. Since, a five-digit number is formed using the digits $\{0, 1, 2, 3, 4 \text{ and } 5\}$ divisible by 3 i.e. only possible when sum of the digits is multiple of three.

Case I Using digits 0, 1, 2, 4, 5

Number of ways = $4 \times 4 \times 3 \times 2 \times 1 = 96$

Case II Using digits 1, 2, 3, 4, 5

Number of ways = $5 \times 4 \times 3 \times 2 \times 1 = 120$

\therefore Total numbers formed = $120 + 96 = 216$

9. Since, the first 2 women select the chairs amongst 1 to 4 in 4P_2 ways. Now, from the remaining 6 chairs, three men could be arranged in 6P_3 .

\therefore Total number of arrangements = ${}^4P_2 \times {}^6P_3$.

10. Total number of five letters words formed from ten different letters = $10 \times 10 \times 10 \times 10 \times 10 = 10^5$

Number of five letters words having no repetition

$$= 10 \times 9 \times 8 \times 7 \times 6 = 30240$$

\therefore Number of words which have at least one letter repeated = $10^5 - 30240 = 69760$

11. Let the two sides be A and B . Assume that four particular guests wish to sit on side A . Four guests who wish to sit on side A can be accommodated on nine chairs in 9P_4 ways and three guests who wish to sit on side B can be accommodated in 9P_3 ways. Now, the remaining guests are left who can sit on 11 chairs on both the sides of the table in $(11!)$ ways. Hence, the total number of ways in which 18 persons can be seated = ${}^9P_4 \times {}^9P_3 \times (11)!$.

82 Permutations and Combinations

12. A. If ENDEA is fixed word, then assume this as a single letter. Total number of letters = 5
Total number of arrangements = 5!
- B. If E is at first and last places, then total number of permutations = $7!/2! = 21 \times 5!$
- C. If D, L, N are not in last five positions
← D, L, N, N → ← E, E, E, A, O →
Total number of permutations = $\frac{4!}{2!} \times \frac{5!}{3!} = 2 \times 5!$
- D. Total number of odd positions = 5
Permutations of AEEEE are $\frac{5!}{3!}$
Total number of even positions = 4
∴ Number of permutations of N, N, D, L = $\frac{4!}{2!}$
⇒ Total number of permutations = $\frac{5!}{3!} \times \frac{4!}{2!} = 2 \times 5!$

Topic 2 Properties of Combinational and General Selections

1. As each section has 5 questions, so number of ways to select 5 questions are

S_1	S_2	S_3
1	1	3
1	3	1
3	1	1
and		
1	2	2
2	1	2
2	2	1

∴ Total number of selection of 5 questions
 $= 3 \times ({}^5C_1 \times {}^5C_1 \times {}^5C_3) + 3 \times ({}^5C_1 \times {}^5C_2 \times {}^5C_2)$
 $= 3(5 \times 5 \times 10) + 3(5 \times 10 \times 10)$
 $= 750 + 1500 = 2250.$

2. Given that, out of 31 objects 10 are identical and remaining 21 are distinct, so in following ways, we can choose 10 objects.

0 identical + 10 distincts, number of ways = $1 \times {}^{21}C_{10}$

1 identical + 9 distincts, number of ways = $1 \times {}^{21}C_9$

2 identicals + 8 distincts, number of ways = $1 \times {}^{21}C_8$

.....

So, total number of ways in which we can choose 10 objects is

$${}^{21}C_{10} + {}^{21}C_9 + {}^{21}C_8 + \dots + {}^{21}C_0 = x \text{ (let)} \quad \dots \text{ (i)}$$

$$\Rightarrow {}^{21}C_{11} + {}^{21}C_{12} + {}^{21}C_{13} + \dots + {}^{21}C_{21} = x \quad \dots \text{ (ii)}$$

[∵ ${}^nC_r = {}^nC_{n-r}$]

On adding both Eqs. (i) and (ii), we get

$$2x = {}^{21}C_0 + {}^{21}C_1 + {}^{21}C_2 + \dots + {}^{21}C_{10} + {}^{21}C_{11} + {}^{21}C_{12} + \dots + {}^{21}C_{21}$$

$$\Rightarrow 2x = 2^{21} \Rightarrow x = 2^{20}$$

3. It is given that, there are 20 pillars of the same height have been erected along the boundary of a circular stadium.

Now, the top of each pillar has been connected by beams with the top of all its non-adjacent pillars, then total number of beams = number of diagonals of 20-sided polygon.

∴ ${}^{20}C_2$ is selection of any two vertices of 20-sided polygon which included the sides as well.

So, required number of total beams = ${}^{20}C_2 - 20$

$$\begin{aligned} [\because \text{the number of diagonals in a } n\text{-sided closed polygon} &= {}^nC_2 - n] \\ &= \frac{20 \times 19}{2} - 20 = 190 - 20 = 170 \end{aligned}$$

4. Let there are n balls used to form the sides of equilateral triangle.

According to the question, we have

$$\frac{n(n+1)}{2} + 99 = (n-2)^2$$

$$\Rightarrow n^2 + n + 198 = 2[n^2 - 4n + 4]$$

$$\Rightarrow n^2 - 9n - 190 = 0$$

$$\Rightarrow n^2 - 19n + 10n - 190 = 0$$

$$\Rightarrow (n-19)(n+10) = 0$$

$$\Rightarrow n = 19, -10$$

$$\Rightarrow n = 19 \quad [\because \text{number of balls } n > 0]$$

Now, number of balls used to form an equilateral triangle is $\frac{n(n+1)}{2}$

$$= \frac{19 \times 20}{2} = 190.$$

5. Since, there are m -men and 2-women and each participant plays two games with every other participant.

∴ Number of games played by the men between themselves = $2 \times {}^mC_2$

and the number of games played between the men and the women = $2 \times {}^mC_1 \times {}^2C_1$

Now, according to the question,

$$2 \times {}^mC_2 = 2 \times {}^mC_1 \times {}^2C_1 + 84$$

$$\Rightarrow \frac{m!}{2!(m-2)!} = m \times 2 + 42$$

$$\Rightarrow m(m-1) = 4m + 84$$

$$\Rightarrow m^2 - m = 4m + 84$$

$$\Rightarrow m^2 - 5m - 84 = 0$$

$$\Rightarrow m^2 - 12m + 7m - 84 = 0$$

$$\Rightarrow m(m-12) + 7(m-12) = 0$$

$$\Rightarrow m = 12$$

[∵ $m > 0$]

6. If nC_4 , nC_5 and nC_6 are in AP, then

$$2 \cdot {}^nC_5 = {}^nC_4 + {}^nC_6$$

[If a, b, c are in AP, then $2b = a + c$]

$$\Rightarrow 2 \frac{n!}{5!(n-5)!} = \frac{n!}{4!(n-4)!} + \frac{n!}{6!(n-6)!}$$

$$\left[\because {}^nC_r = \frac{n!}{r!(n-r)!} \right]$$

$$\begin{aligned} &\Rightarrow \frac{2}{5 \cdot 4!(n-5)(n-6)!} \\ &= \frac{1}{4!(n-4)(n-5)(n-6)!} + \frac{1}{6 \cdot 5 \cdot 4!(n-6)!} \\ &\Rightarrow \frac{2}{5(n-5)} = \frac{1}{(n-4)(n-5)} + \frac{1}{30} \\ &\Rightarrow \frac{2}{5(n-5)} = \frac{30 + (n-4)(n-5)}{30(n-4)(n-5)} \\ &\Rightarrow 12(n-4) = 30 + n^2 - 9n + 20 \\ &\Rightarrow n^2 - 21n + 98 = 0 \\ &\Rightarrow n^2 - 14n - 7n + 98 = 0 \\ &\Rightarrow n(n-14) - 7(n-14) = 0 \\ &\Rightarrow (n-7)(n-14) = 0 \\ &\Rightarrow n = 7 \text{ or } 14 \end{aligned}$$

7. Given, $\sum_{r=0}^{25} \{ {}^{50}C_r \cdot {}^{50-r}C_{25-r} \} = K \cdot {}^{50}C_{25}$

$$\begin{aligned} &\Rightarrow \sum_{r=0}^{25} \left(\frac{50!}{r!(50-r)!} \times \frac{(50-r)!}{(25-r)!25!} \right) = K \cdot {}^{50}C_{25} \\ &\Rightarrow \sum_{r=0}^{25} \left(\frac{50!}{25!25!} \times \frac{25!}{r!(25-r)!} \right) = K \cdot {}^{50}C_{25} \\ &\quad \text{[on multiplying 25! in numerator and denominator.]} \\ &\Rightarrow {}^{50}C_{25} \sum_{r=0}^{25} {}^{25}C_r = K \cdot {}^{50}C_{25} \quad \left[\because {}^{50}C_{25} = \frac{50!}{25!25!} \right] \\ &\Rightarrow K = \sum_{r=0}^{25} {}^{25}C_r = 2^{25} \\ &\quad [\because {}^nC_0 + {}^nC_1 + {}^nC_2 + \dots + {}^nC_n = 2^n] \\ &\Rightarrow K = 2^{25} \end{aligned}$$

8. Given,

$$\begin{aligned} &\sum_{i=1}^{20} \left(\frac{{}^{20}C_{i-1}}{{}^{20}C_i + {}^{20}C_{i-1}} \right)^3 = \frac{k}{21} \\ &\Rightarrow \sum_{i=1}^{20} \left(\frac{{}^{20}C_{i-1}}{{}^{21}C_i} \right)^3 = \frac{k}{21} \quad (\because {}^nC_r + {}^nC_{r-1} = {}^{n+1}C_r) \\ &\Rightarrow \sum_{i=1}^{20} \left(\frac{{}^{20}C_{i-1}}{\frac{21}{i} {}^{20}C_{i-1}} \right)^3 = \frac{k}{21} \quad \left(\because {}^nC_r = \frac{n}{r} {}^{n-1}C_{r-1} \right) \\ &\Rightarrow \sum_{i=1}^{20} \left(\frac{i}{21} \right)^3 = \frac{k}{21} \\ &\Rightarrow \frac{1}{(21)^3} \sum_{i=1}^{20} i^3 = \frac{k}{21} \\ &\Rightarrow \frac{1}{(21)^3} \left[\frac{n(n+1)^2}{2} \right]_{n=20} = \frac{k}{21} \\ &\quad \left[\because 1^3 + 2^3 + \dots + n^3 = \left[\frac{n(n+1)}{2} \right]^2 \right] \\ &\Rightarrow k = \frac{21}{(21)^3} \left(\frac{20 \times 21}{2} \right)^2 = 100 \\ &\therefore k = 100 \end{aligned}$$

9. Given, X has 7 friends, 4 of them are ladies and 3 are men while Y has 7 friends, 3 of them are ladies and 4 are men.

\therefore Total number of required ways

$$\begin{aligned} &= {}^3C_3 \times {}^4C_0 \times {}^4C_0 \times {}^3C_3 + {}^3C_2 \times {}^4C_1 \times {}^4C_1 \times {}^3C_2 \\ &\quad + {}^3C_1 \times {}^4C_2 \times {}^4C_2 \times {}^3C_1 + {}^3C_0 \times {}^4C_3 \times {}^4C_3 \times {}^3C_0 \\ &= 1 + 144 + 324 + 16 = 485 \end{aligned}$$

10. $N_i = {}^5C_k \times {}^4C_{5-k}$

$$\begin{aligned} N_1 &= 5 \times 1 \\ N_2 &= 10 \times 4 \\ N_3 &= 10 \times 6 \\ N_4 &= 5 \times 4 \\ N_5 &= 1 \\ N_1 + N_2 + N_3 + N_4 + N_5 &= 126 \end{aligned}$$

11. We have, 6 girls and 4 boys. To select 4 members (atmost one boy)

i.e. (1 boy and 3 girls) or (4 girls) = ${}^6C_3 \cdot {}^4C_1 + {}^6C_4$... (i)

Now, selection of captain from 4 members = 4C_1 ... (ii)

\therefore Number of ways to select 4 members (including the selection of a captain, from these 4 members)

$$= ({}^6C_3 \cdot {}^4C_1 + {}^6C_4) \cdot {}^4C_1 = (20 \times 4 + 15) \times 4 = 380$$

12. Given, $T_n = {}^nC_3 \Rightarrow T_{n+1} = {}^{n+1}C_3$

$\therefore T_{n+1} - T_n = {}^{n+1}C_3 - {}^nC_3 = 10$ [given]

$\Rightarrow {}^nC_2 + {}^nC_3 - {}^nC_3 = 10$ [$\because {}^nC_r + {}^nC_{r+1} = {}^{n+1}C_{r+1}$]

$\Rightarrow {}^nC_2 = 10 \Rightarrow n = 5$

13. Since, r, s, t are prime numbers.

\therefore Selection of p and q are as under

p	q	Number of ways
r^0	r^2	1 way
r^1	r^2	1 way
r^2	r^0, r^1, r^2	3 ways

\therefore Total number of ways to select, r = 5

Selection of s as under

s^0	s^4	1 way
s^1	s^4	1 way
s^2	s^4	1 way
s^3	s^4	1 way
s^4		5 ways

\therefore Total number of ways to select s = 9

Similarly, the number of ways to select t = 5

\therefore Total number of ways = $5 \times 9 \times 5 = 225$

14. Here, ${}^{47}C_4 + \sum_{j=1}^5 {}^{52-j}C_3$

$$\begin{aligned} &= {}^{47}C_4 + {}^{51}C_3 + {}^{50}C_3 + {}^{49}C_3 + {}^{48}C_3 + {}^{47}C_3 \\ &= ({}^{47}C_4 + {}^{47}C_3) + {}^{48}C_3 + {}^{49}C_3 + {}^{50}C_3 + {}^{51}C_3 \\ &\quad \text{[using } {}^nC_r + {}^nC_{r-1} = {}^{n+1}C_r \text{]} \end{aligned}$$

84 Permutations and Combinations

$$\begin{aligned}
 &= ({}^{48}C_4 + {}^{48}C_3) + {}^{49}C_3 + {}^{50}C_3 + {}^{51}C_3 \\
 &= ({}^{49}C_4 + {}^{49}C_3) + {}^{50}C_3 + {}^{51}C_3 \\
 &= ({}^{50}C_4 + {}^{50}C_3) + {}^{51}C_3 = {}^{51}C_4 + {}^{51}C_3 = {}^{52}C_4
 \end{aligned}$$

15. Given 6 boys $M_1, M_2, M_3, M_4, M_5, M_6$ and 5 girls G_1, G_2, G_3, G_4, G_5

(i) $\alpha_1 \rightarrow$ Total number of ways of selecting 3 boys and 2 girls from 6 boys and 5 girls.

$$\text{i.e., } {}^6C_3 \times {}^5C_2 = 20 \times 10 = 200$$

$$\therefore \alpha_1 = 200$$

(ii) $\alpha_2 \rightarrow$ Total number of ways selecting at least 2 member and having equal number of boys and girls

$$\text{i.e., } {}^6C_1 {}^5C_1 + {}^6C_2 {}^5C_2 + {}^6C_3 {}^5C_3 + {}^6C_4 {}^5C_4 + {}^6C_5 {}^5C_5$$

$$= 30 + 150 + 200 + 75 + 6 = 461$$

$$\Rightarrow \alpha_2 = 461$$

(iii) $\alpha_3 \rightarrow$ Total number of ways of selecting 5 members in which at least 2 of them girls

$$\text{i.e., } {}^5C_2 {}^6C_3 + {}^5C_3 {}^6C_2 + {}^5C_4 {}^6C_1 + {}^5C_5 {}^6C_0$$

$$= 200 + 150 + 30 + 1 = 381$$

$$\alpha_3 = 381$$

(iv) $\alpha_4 \rightarrow$ Total number of ways of selecting 4 members in which at least two girls such that M_1 and G_1 are not included together.

$$G_1 \text{ is included} \rightarrow {}^4C_1 \cdot {}^5C_2 + {}^4C_2 \cdot {}^5C_1 + {}^4C_3$$

$$= 40 + 30 + 4 = 74$$

$$M_1 \text{ is included} \rightarrow {}^4C_2 \cdot {}^5C_1 + {}^4C_3 = 30 + 4 = 34$$

G_1 and M_1 both are not included

$${}^4C_4 + {}^4C_3 \cdot {}^5C_1 + {}^4C_2 \cdot {}^5C_2$$

$$1 + 20 + 60 = 81$$

$$\therefore \text{Total number} = 74 + 34 + 81 = 189$$

$$\alpha_4 = 189$$

Now, $P \rightarrow 4; Q \rightarrow 6; R \rightarrow 5; S \rightarrow 2$

Hence, option (c) is correct.

16. Given that, no two persons sitting adjacent in circular arrangement, have hats of same colour. So, only possible combination due to circular arrangement is $2 + 2 + 1$.

So, there are following three cases of selecting hats are $2R + 2B + 1G$ or $2B + 2G + 1R$ or $2G + 2R + 1B$.

To distribute these 5 hats first we will select a person which we can done in 5C_1 ways and distribute that hat which is one of it's colour. And, now the remaining four hats can be distributed in two ways.

So, total ways will be $3 \times {}^5C_1 \times 2 = 3 \times 5 \times 2 = 30$

17. **PLAN** Number of line segment joining pair of adjacent point = n

Number of line segment obtained joining n points on a circle = nC_2

Number of red line segments = ${}^nC_2 - n$

Number of blue line segments = n

$$\therefore {}^nC_2 - n = n$$

$$\Rightarrow \frac{n(n-1)}{2} = 2n$$

$$\Rightarrow n = 5$$

18. Let $A = \{x_1, x_2, \dots, x_n\}$

\therefore Number of functions from A to A is n^n and out of these

$$\sum_{r=1}^n (-1)^{n-r} {}^nC_r (r)^n \text{ are onto functions.}$$

19. The number of students answering exactly k ($1 \leq k \leq n-1$) questions wrongly is $2^{n-k} - 2^{n-k-1}$. The number of students answering all questions wrongly is 2^0 .

Thus, total number of wrong answers

$$= 1(2^{n-1} - 2^{n-2}) + 2(2^{n-2} - 2^{n-3}) + \dots$$

$$+ (n-1)(2^1 - 2^0) + 2^0 \cdot n$$

$$= 2^{n-1} + 2^{n-2} + 2^{n-3} + \dots + 2^1 + 2^0 = 2^n - 1$$

20. Let r consecutive integers be $x+1, x+2, \dots, x+r$.

$$\therefore (x+1)(x+2)\dots(x+r) = \frac{(x+r)(x+r-1)\dots(x+1)x!}{x!}$$

$$= \frac{(x+r)!}{(x)!} \cdot \frac{r!}{r!} = {}^{x+r}C_r \cdot (r)!$$

Thus, $(x+1)(x+2)\dots(x+r) = {}^{x+r}C_r \cdot (r)!$, which is clearly divisible by $(r)!$. Hence, it is a true statement.

21. Given that, there are 9 women and 8 men, a committee of 12 is to be formed including at least 5 women.

This can be done in

$$= (5 \text{ women and } 7 \text{ men}) + (6 \text{ women and } 6 \text{ men})$$

$$+ (7 \text{ women and } 5 \text{ men}) + (8 \text{ women and } 4 \text{ men})$$

$$+ (9 \text{ women and } 3 \text{ men}) \text{ ways}$$

Total number of ways of forming committee

$$= ({}^9C_5 \cdot {}^8C_7) + ({}^9C_6 \cdot {}^8C_6) + ({}^9C_7 \cdot {}^8C_5)$$

$$+ ({}^9C_8 \cdot {}^8C_4) + ({}^9C_9 \cdot {}^8C_3)$$

$$= 1008 + 2352 + 2016 + 630 + 56 = 6062$$

(i) The women are in majority = $2016 + 630 + 56$

$$= 2702$$

(ii) The man are in majority = 1008 ways

22. Since, student is allowed to select at most n books out of $(2n+1)$ books.

$$\therefore {}^{2n+1}C_1 + {}^{2n+1}C_2 + \dots + {}^{2n+1}C_n = 63 \quad \dots (i)$$

We know ${}^{2n+1}C_0 + {}^{2n+1}C_1 + \dots + {}^{2n+1}C_{2n+1} = 2^{2n+1}$

$$\Rightarrow 2({}^{2n+1}C_0 + {}^{2n+1}C_1 + {}^{2n+1}C_2 + \dots + {}^{2n+1}C_n) = 2^{2n+1}$$

$$\Rightarrow {}^{2n+1}C_1 + {}^{2n+1}C_2 + \dots + {}^{2n+1}C_n = (2^{2n} - 1) \quad \dots (ii)$$

From Eqs. (i) and (ii), we get

$$2^{2n} - 1 = 63$$

$$\Rightarrow 2^{2n} = 64$$

$$\Rightarrow 2n = 6$$

$$\Rightarrow n = 3$$

23. **Case I** When one black and two others balls are drawn.

$$\Rightarrow \text{Number of ways} = {}^3C_1 \cdot {}^6C_2 = 45$$

Case II When two black and one other balls are drawn

$$\Rightarrow \text{Number of ways} = {}^3C_2 \cdot {}^6C_1 = 18$$

Case III When all three black balls are drawn
 \Rightarrow Number of ways = ${}^3C_3 = 1$
 \therefore Total number of ways = $45 + 18 + 1 = 64$

24. The possible cases are

Case I A man invites 3 ladies and women invites 3 gentlemen.

Number of ways = ${}^4C_3 \cdot {}^4C_3 = 16$

Case II A man invites (2 ladies, 1 gentleman) and women invites (2 gentlemen, 1 lady).

Number of ways = $({}^4C_2 \cdot {}^3C_1) \cdot ({}^3C_1 \cdot {}^4C_2) = 324$

Case III A man invites (1 lady, 2 gentlemen) and women invites (2 ladies, 1 gentleman).

Number of ways = $({}^4C_1 \cdot {}^3C_2) \cdot ({}^3C_2 \cdot {}^4C_1) = 144$

Case IV A man invites (3 gentlemen) and women invites (3 ladies).

Number of ways = ${}^3C_3 \cdot {}^3C_3 = 1$

\therefore Total number of ways,
 $= 16 + 324 + 144 + 1 = 485$

25. Since, m men and n women are to be seated in a row so that no two women sit together. This could be shown as

$$\times M_1 \times M_2 \times M_3 \times \dots \times M_m \times$$

which shows there are $(m + 1)$ places for n women.

\therefore Number of ways in which they can be arranged
 $= (m)! \cdot {}^{m+1}P_n = \frac{(m)! \cdot (m+1)!}{(m+1-n)!}$

26. Let mn squares of equal size are arrange to form a rectangle of dimension m by n . Shown as, from figure.

neighbours of x_1 are $\{x_2, x_3, x_4, x_5\}$ x_5 are $\{x_1, x_6, x_7\}$ and x_7 are $\{x_5, x_4\}$.

$$\Rightarrow x_1 = \frac{x_2 + x_3 + x_4 + x_5}{4}, \quad x_5 = \frac{x_1 + x_6 + x_7}{3}$$

and $x_7 = \frac{x_4 + x_5}{2}$

$$\therefore 4x_1 = x_2 + x_3 + x_4 + \frac{x_1 + x_6 + x_7}{3}$$

$$\Rightarrow 12x_1 = 3x_2 + 3x_3 + 3x_4 + x_1 + x_6 + \frac{x_4 + x_5}{2}$$

$$\Rightarrow 24x_1 = 6x_2 + 6x_3 + 6x_4 + 2x_1 + 2x_6 + x_4 + x_5$$

$$\Rightarrow 22x_1 = 6x_2 + 6x_3 + 7x_4 + x_5 + 2x_6$$

where, $x_1, x_2, x_3, x_4, x_5, x_6$ are all the natural numbers and x_1 is linearly expressed as the sum of x_2, x_3, x_4, x_5, x_6 where sum of coefficients are equal only if, all observations are same.

$$\Rightarrow x_2 = x_3 = x_4 = x_5 = x_6$$

\Rightarrow All the numbers used are equal.

27. We know that, $\frac{{}^nC_r}{{}^nC_{r-1}} = \frac{n-r+1}{r}$

$$\Rightarrow \frac{84}{36} = \frac{7}{3} = \frac{n-r+1}{r} \quad \text{[given]}$$

$$\Rightarrow 3n - 10r + 3 = 0 \quad \dots(i)$$

Also given, $\frac{{}^nC_r}{{}^nC_{r+1}} = \frac{84}{126}$

$$\Rightarrow \frac{r+1}{n-r} = \frac{2}{3}$$

$$\Rightarrow 2n - 5r - 3 = 0 \quad \dots(ii)$$

On solving Eqs. (i) and (ii), we get

$$r = 3 \quad \text{and} \quad n = 9$$

Topic 3 Multinomial, Repeated Arrangement and Selection

1. **Key Idea** Use divisibility test of 11 and consider different situation according to given condition.

Since, the sum of given digits

$$0 + 1 + 2 + 5 + 7 + 9 = 24$$

Let the six-digit number be $abcdef$ and to be divisible by 11, so the difference of sum of odd placed digits and sum of even placed digits should be either 0 or a multiple of 11 means $|(a + c + e) - (b + d + f)|$ should be either 0 or a multiple of 11.

Hence, possible case is $a + c + e = 12 = b + d + f$ (only)

Now, **Case I**

set $\{a, c, e\} = \{0, 5, 7\}$ and set $\{b, d, f\} = \{1, 2, 9\}$

So, number of 6-digits numbers = $(2 \times 2!) \times (3!) = 24$

[$\because a$ can be selected in ways only either 5 or 7].

Case II

Set $\{a, c, e\} = \{1, 2, 9\}$ and set $\{b, d, f\} = \{0, 5, 7\}$

So, number of 6-digits numbers = $3! \times 3! = 36$

So, total number of 6-digits numbers = $24 + 36 = 60$

2. Since there are 8 males and 5 females. Out of these 13 members committee of 11 members is to be formed.

According to the question, m = number of ways when there is at least 6 males

$$= ({}^8C_6 \times {}^5C_5) + ({}^8C_7 \times {}^5C_4) + ({}^8C_8 \times {}^5C_3)$$

$$= (28 \times 1) + (8 \times 5) + (1 \times 10) = 28 + 40 + 10 = 78$$

and n = number of ways when there is at least 3 females

$$= ({}^5C_3 \times {}^8C_8) + ({}^5C_4 \times {}^8C_7) + ({}^5C_5 \times {}^8C_6)$$

$$= 10 \times 1 + 5 \times 8 + 1 \times 28 = 78$$

So, $m = n = 78$

3. Given there are three boxes, each containing 10 balls labelled 1, 2, 3, ..., 10.

Now, one ball is randomly drawn from each boxes, and n_i denote the label of the ball drawn from the i th box, ($i = 1, 2, 3$).

Then, the number of ways in which the balls can be chosen such that $n_1 < n_2 < n_3$ is same as selection of 3 different numbers from numbers $\{1, 2, 3, \dots, 10\} = {}^{10}C_3 = 120$.

4. Using the digits 0, 1, 3, 7, 9

number of one digit natural numbers that can be formed = 4,

86 Permutations and Combinations

number of two digit natural numbers that can be formed = 20,



(\because 0 can not come in 1st box)

number of three digit natural numbers that can be formed = 100

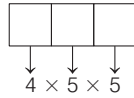

and number of four digit natural numbers less than 7000, that can be formed = 250

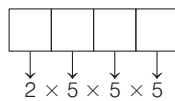

(\because only 1 or 3 can come in 1st box)

\therefore Total number of natural numbers formed
 $= 4 + 20 + 100 + 250 = 374$

5. Number of girls in the class = 5 and number of boys in the class = 7

Now, total ways of forming a team of 3 boys and 2 girls

$$= {}^7C_3 \cdot {}^5C_2 = 350$$

But, if two specific boys are in team, then number of ways = ${}^5C_1 \cdot {}^5C_2 = 50$

Required ways, i.e. the ways in which two specific boys are not in the same team = $350 - 50 = 300$.

Alternate Method

Number of ways when A is selected and B is not

$$= {}^5C_2 \cdot {}^5C_2 = 100$$

Number of ways when B is selected and A is not

$$= {}^5C_2 \cdot {}^5C_2 = 100$$

Number of ways when both A and B are not selected

$$= {}^5C_3 \cdot {}^5C_2 = 100$$

\therefore Required ways = $100 + 100 + 100 = 300$.

6. Clearly, number of words start with $A = \frac{4!}{2!} = 12$

Number of words start with $L = 4! = 24$

Number of words start with $M = \frac{4!}{2!} = 12$

Number of words start with $SA = \frac{3!}{2!} = 3$

Number of words start with $SL = 3! = 6$

Note that, next word will be "SMALL".

Hence, the position of word "SMALL" is 58th.

7. Arrange the letters of the word COCHIN as in the order of dictionary CCHINO.

Consider the words starting from C.

There are $5!$ such words. Number of words with the two C's occupying first and second place = $4!$.

Number of words starting with CH, CI, CN is $4!$ each.

Similarly, number of words before the first word starting with CO = $4! + 4! + 4! + 4! = 96$.

The word starting with CO found first in the dictionary is COCHIN. There are 96 words before COCHIN.

8. Let the engineer visits the factory first time after x_1 days to 1 June, second time after x_2 days to first visit and so on.

$$\therefore x_1 + x_2 + x_3 + x_4 + x_5 = 11$$

where $x_1, x_5 \geq 0$ and $x_2, x_3, x_4 \geq 1$ according to the requirement of the question.

Now, let $x_2 = a + 1$, $x_3 = b + 1$ and $x_4 = c + 1$ where $a, b, c \geq 0$

\therefore New equation will be

$$x_1 + a + b + c + x_5 = 8$$

Now, the number of all possible ways in which the engineer can made visits is equals to the non-negative integral solution of equation

$$x_1 + a + b + c + x_5 = 8, \text{ and it is equal to } {}^{8+5-1}C_{5-1} = {}^{12}C_4 = \frac{12 \times 11 \times 10 \times 9}{4 \times 3 \times 2} = 495.$$

9. Given word in MOTHER, now alphabetical order of letters is EHMORT, so number of words start with letter.

E ----- is $5!$

H ----- is $5!$

M E ----- is $4!$

M H ----- is $4!$

M O E ----- is $3!$

M O H ----- is $3!$

M O R ----- is $3!$

M O T E ----- is $2!$

M O T H E R is 1

So, position of the word 'MOTHER' is

$$5! + 5! + 4! + 4! + 3! + 3! + 3! + 2! + 1$$

$$= 120 + 120 + 24 + 24 + 6 + 6 + 6 + 2 + 1 = 309$$

10. A number is divisible by 4 if last 2 digit number is divisible by 4.

\therefore Last two digit number divisible by 4 from (1, 2, 3, 4, 5) are 12, 24, 32, 44, 52

\therefore The number of 5 digit number which are divisible by 4, from the digit (1, 2, 3, 4, 5) and digit is repeated is

$$5 \times 5 \times 5 \times (5 \times 1) = 625$$

11. $x = 10!$

$$y = {}^{10}C_1 \times {}^9C_8 \times \frac{10!}{2!} = 10 \times 9 \times \frac{10!}{2} \Rightarrow \frac{y}{9x} = \frac{10}{2} = 5$$

12. Here, $_ B_1 _ B_2 _ B_3 _ B_4 _ B_5 _$

Out of 5 girls, 4 girls are together and 1 girl is separate. Now, to select 2 positions out of 6 positions between boys = 6C_2 ... (i)

4 girls are to be selected out of 5 = 5C_4 ... (ii)

Now, 2 groups of girls can be arranged in $2!$ ways. ... (iii)

Also, the group of 4 girls and 5 boys is arranged in $4! \times 5!$ ways. ... (iv)

Now, total number of ways = ${}^6C_2 \times {}^5C_4 \times 2! \times 4! \times 5!$
 [from Eqs. (i), (ii), (iii) and (iv)]

$\therefore m = {}^6C_2 \times {}^5C_4 \times 2! \times 4! \times 5!$

and $n = 5! \times 6!$

$\Rightarrow \frac{m}{n} = \frac{{}^6C_2 \times {}^5C_4 \times 2! \times 4! \times 5!}{6! \times 5!} = \frac{15 \times 5 \times 2 \times 4!}{6 \times 5 \times 4!} = 5$

13. **PLAN** Reducing the equation to a newer equation, where sum of variables is less. Thus, finding the number of arrangements becomes easier.

As, $n_1 \geq 1, n_2 \geq 2, n_3 \geq 3, n_4 \geq 4, n_5 \geq 5$

Let $n_1 - 1 = x_1 \geq 0, n_2 - 2 = x_2 \geq 0, \dots, n_5 - 5 = x_5 \geq 0$

\Rightarrow New equation will be

$x_1 + 1 + x_2 + 2 + \dots + x_5 + 5 = 20$

$\Rightarrow x_1 + x_2 + x_3 + x_4 + x_5 = 20 - 15 = 5$

Now, $x_1 \leq x_2 \leq x_3 \leq x_4 \leq x_5$

x_1	x_2	x_3	x_4	x_5
0	0	0	0	5
0	0	0	1	4
0	0	0	2	3
0	0	1	1	3
0	0	1	2	2
0	1	1	1	2
1	1	1	1	1

So, 7 possible cases will be there.

14. The number of solutions of $x_1 + x_2 + \dots + x_k = n$
 = Coefficient of t^n in $(t + t^2 + t^3 + \dots)(t^2 + t^3 + \dots) \dots$
 $(t^k + t^{k+1} + \dots)$

= Coefficient of t^n in $t^{1+2+\dots+k} (1 + t + t^2 + \dots)^k$

Now, $1 + 2 + \dots + k = \frac{k(k+1)}{2} = p$ [say]

and $1 + t + t^2 + \dots = \frac{1}{1-t}$

Thus, the number of required solutions

= Coefficient of t^{n-p} in $(1-t)^{-k}$

= Coefficient of t^{n-p} in $[1 + {}^kC_1 t + {}^{k+1}C_2 t^2 + {}^{k+2}C_3 t^3 + \dots]$

= ${}^{k+n-p-1}C_{n-p} = {}^rC_{n-p}$

where, $r = k + n - p - 1 = k + n - 1 - \frac{1}{2}k(k+1)$

$= \frac{1}{2}(2k + 2n - 2 + k^2 - k)$

$= \frac{1}{2}(2n - k^2 + k - 2)$

15. Since, six '+' signs are + + + + + +
 \therefore 4 negative sign has seven places to be arranged in
 $\Rightarrow {}^7C_4$ ways = 35 ways

16. Since, each box can hold five balls.
 \therefore Number of ways in which balls could be distributed so that none is empty, are (2, 2, 1) or (3, 1, 1).

i.e. $({}^5C_2 {}^3C_2 {}^1C_1 + {}^5C_3 {}^2C_1 {}^1C_1) \times 3!$
 $= (30 + 20) \times 6 = 300$

Topic 4 Distribution of Object into Group

1. It is given that a group of students comprises of 5 boys and n girls. The number of ways, in which a team of 3 students can be selected from this group such that each team consists of at least one boy and at least one girls, is = (number of ways selecting one boy and 2 girls) + (number of ways selecting two boys and 1 girl)

= $({}^5C_1 \times {}^nC_2) + ({}^5C_2 \times {}^nC_1) = 1750$ [given]

$\Rightarrow \left(5 \times \frac{n(n-1)}{2}\right) + \left(\frac{5 \times 4}{2} \times n\right) = 1750$

$\Rightarrow n(n-1) + 4n = \frac{2}{5} \times 1750 \Rightarrow n^2 + 3n = 2 \times 350$

$\Rightarrow n^2 + 3n - 700 = 0 \Rightarrow n^2 + 28n - 25n - 700 = 0$

$\Rightarrow n(n+28) - 25(n+28) = 0 \Rightarrow (n+28)(n-25) = 0$

$\Rightarrow n = 25$ [$\because n \in N$]

2. According to given information, we have the following figure.

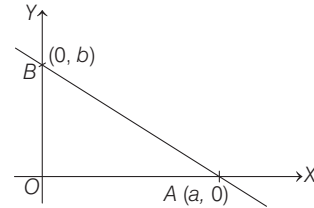

(Note that as a and b are integers so they can be negative also). Here $O(0,0)$, $A(a,0)$ and $B(0,b)$ are the three vertices of the triangle.

Clearly, $OA = |a|$ and $OB = |b|$.

\therefore Area of $\Delta OAB = \frac{1}{2} |a| |b|$.

But area of such triangles is given as 50 sq units.

$\therefore \frac{1}{2} |a| |b| = 50$

$\Rightarrow |a| |b| = 100 = 2^2 \cdot 5^2$

Number of ways of distributing two 2's in $|a|$ and $|b| = 3$

$ a $	$ b $
0	2
1	1
2	0

$\Rightarrow 3$ ways

Similarly, number of ways of distributing two 5's in $|a|$ and $|b| = 3$ ways.

\therefore Total number of ways of distributing 2's and 5's = $3 \times 3 = 9$ ways

Note that for one value of $|a|$, there are 2 possible values of a and for one value of $|b|$, there are 2 possible values of b .

\therefore Number of such triangles possible = $2 \times 2 \times 9 = 36$.

So, number of elements in S is 36.

3. Given 6 different novels and 3 different dictionaries.

Number of ways of selecting 4 novels from 6 novels is

${}^6C_4 = \frac{6!}{2!4!} = 15$

88 Permutations and Combinations

Number of ways of selecting 1 dictionary is from 3 dictionaries is ${}^3C_1 = \frac{3!}{1!2!} = 3$

\therefore Total number of arrangement of 4 novels and 1 dictionary where dictionary is always in the middle, is
 $15 \times 3 \times 4! = 45 \times 24 = 1080$

4.	Objects	Groups	Objects	Groups
	Distinct	Distinct	Identical	Identical
	Distinct	Identical	Identical	Distinct

Description of Situation Here, 5 distinct balls are distributed amongst 3 persons so that each gets at least one ball. i.e. Distinct \rightarrow Distinct

So, we should make cases

$$\text{Case I } \left. \begin{array}{ccc} A & B & C \\ 1 & 1 & 2 \end{array} \right\} \quad \text{Case II } \left. \begin{array}{ccc} A & B & C \\ 1 & 2 & 2 \end{array} \right\}$$

Number of ways to distribute 5 balls

$$= \left({}^5C_1 \cdot {}^4C_1 \cdot {}^3C_3 \times \frac{3!}{2!} \right) + \left({}^5C_1 \cdot {}^4C_2 \cdot {}^2C_2 \times \frac{3!}{2!} \right)$$

$$= 60 + 90 = 150$$

5. Total number of arrangements of word BANANA

$$= \frac{6!}{3!2!} = 60$$

The number of arrangements of words BANANA in which two N's appear adjacently = $\frac{5!}{3!} = 20$

Required number of arrangements = $60 - 20 = 40$

6. Here, n^2 objects are distributed in n groups, each group containing n identical objects.

\therefore Number of arrangements

$$= {}^{n^2}C_n \cdot {}^{n^2-n}C_n \cdot {}^{n^2-2n}C_n \cdot {}^{n^2-3n}C_n \cdot {}^{n^2-4n}C_n \dots {}^nC_n$$

$$= \frac{(n^2)!}{n!(n^2-n)!} \cdot \frac{(n^2-n)!}{n!(n^2-2n)!} \dots \frac{n!}{n! \cdot 1} = \frac{(n^2)!}{(n!)^n}$$

\Rightarrow Integer (as number of arrangements has to be integer).

7. (i) The number of ways in which 52 cards be divided equally among four players in order

$$= {}^{52}C_{13} \times {}^{39}C_{13} \times {}^{26}C_{13} \times {}^{13}C_{13} = \frac{(52)!}{(13!)^4}$$

- (ii) The number of ways in which a pack of 52 cards can be divided equally into four groups of 13 cards

$$\text{each} = \frac{{}^{52}C_{13} \times {}^{39}C_{13} \times {}^{26}C_{13} \times {}^{13}C_{13}}{4!} = \frac{(52)!}{4!(13!)^4}$$

- (iii) The number of ways in which a pack of 52 cards be divided into 4 sets, three of them having 17 cards each and the fourth just one card

$$= \frac{{}^{52}C_{17} \times {}^{35}C_{18} \times {}^{18}C_{17} \times {}^1C_1}{3!} = \frac{(52)!}{3!(17!)^3}$$

8. The groups of persons can be made only in 2, 2, 1, 1

\therefore So the number of required ways is equal to number of ways to distribute the 6 distinct objects in group sizes 1, 1, 2 and 2

$$= \frac{6!}{(2!)^2 (1!)^2 (2!) (2!)}$$

$$= 360 \times 3 = 1080.$$

Topic 5 Dearrangement and Number of Divisors

1. Since, $240 = 2^4 \cdot 3 \cdot 5$

\therefore Total number of divisors = $(4+1)(2)(2) = 20$

Out of these 2, 6, 10, and 30 are of the form $4n+2$.

2. The number of ways in which the ball does not go its own colour box = $4! \left(1 - \frac{1}{1!} + \frac{1}{2!} - \frac{1}{3!} + \frac{1}{4!} \right)$

$$= 4! \left(1 - \frac{1}{1!} + \frac{1}{2!} - \frac{1}{3!} + \frac{1}{4!} \right)$$

$$= 4! \left(\frac{1}{2} - \frac{1}{6} + \frac{1}{24} \right)$$

$$= 24 \left(\frac{12-4+1}{24} \right) = 9$$

5

Binomial Theorem

Topic 1 Binomial Expansion and General Term

Objective Questions I (Only one correct option)

1. If the constant term in the binomial expansion of $\left(\sqrt{x} - \frac{k}{x^2}\right)^{10}$ is 405, then $|k|$ equals (2020 Main, 6 Sep II)

- (a) 9 (b) 1 (c) 3 (d) 2

2. If α and β be the coefficients of x^4 and x^2 respectively in the expansion of $(x + \sqrt{x^2 - 1})^6 + (x - \sqrt{x^2 - 1})^6$, then

(2020 Main, 8 Jan II)

- (a) $\alpha + \beta = -30$ (b) $\alpha - \beta = -132$
(c) $\alpha + \beta = 60$ (d) $\alpha - \beta = 60$

3. The coefficient of x^{18} in the product $(1+x)(1-x)^{10}(1+x+x^2)^9$ is (2019 Main, 12 April I)

- (a) 84 (b) -126 (c) -84 (d) 126

4. If the coefficients of x^2 and x^3 are both zero, in the expansion of the expression $(1+ax+bx^2)(1-3x)^{15}$ in powers of x , then the ordered pair (a, b) is equal to (2019 Main, 10 April I)

- (a) (28, 315) (b) (-21, 714)
(c) (28, 861) (d) (-54, 315)

5. The term independent of x in the expansion of $\left(\frac{1}{60} - \frac{x^8}{81}\right) \cdot \left(2x^2 - \frac{3}{x^2}\right)^6$ is equal to (2019 Main, 12 April II)

- (a) -72 (b) 36 (c) -36 (d) -108

6. The smallest natural number n , such that the coefficient of x in the expansion of $\left(x^2 + \frac{1}{x^3}\right)^n$ is ${}^n C_{23}$, is (2019 Main, 10 April II)

- (a) 35 (b) 23 (c) 58 (d) 38

7. If some three consecutive coefficients in the binomial expansion of $(x+1)^n$ in powers of x are in the ratio 2 : 15 : 70, then the average of these three coefficients is (2019 Main, 9 April II)

- (a) 964 (b) 227
(c) 232 (d) 625

8. If the fourth term in the binomial expansion of $\left(\frac{2}{x} + x^{\log_8 x}\right)^6$ ($x > 0$) is 20×8^7 , then the value of x is (2019 Main, 9 April I)

- (a) 8^{-2} (b) 8^3
(c) 8 (d) 8^2

9. If the fourth term in the binomial expansion of

$$\left(\sqrt{x^{\left(\frac{1}{1+\log_{10} x}\right)}} + x^{\frac{1}{12}}\right)^6$$
 is equal to 200, and $x > 1$, then the

value of x is (2019 Main, 8 April II)

- (a) 100 (b) 10^4 (c) 10 (d) 10^3

10. The sum of the coefficients of all even degree terms is x in the expansion of (2019 Main, 8 April I)

$$(x + \sqrt{x^3 - 1})^6 + (x - \sqrt{x^3 - 1})^6, (x > 1)$$
 is equal to

- (a) 29 (b) 32 (c) 26 (d) 24

11. The total number of irrational terms in the binomial expansion of $(7^{1/5} - 3^{1/10})^{60}$ is (2019 Main, 12 Jan II)

- (a) 49 (b) 48 (c) 54 (d) 55

12. The ratio of the 5th term from the beginning to the 5th term from the end in the binomial expansion of

$$\left(2^{\frac{1}{3}} + \frac{1}{2(3)^{\frac{1}{3}}}\right)^{10}$$
 is (2019 Main, 12 Jan I)

- (a) 1 : $2(6)^{\frac{1}{3}}$ (b) 1 : $4(16)^{\frac{1}{3}}$ (c) $4(36)^{\frac{1}{3}} : 1$ (d) $2(36)^{\frac{1}{3}} : 1$

13. The sum of the real values of x for which the middle term in the binomial expansion of $\left(\frac{x^3}{3} + \frac{3}{x}\right)^8$ equals

5670 is (2019 Main, 11 Jan I)

- (a) 4 (b) 0 (c) 6 (d) 8

14. The positive value of λ for which the coefficient of x^2 in the expression $x^2 \left(\sqrt{x} + \frac{\lambda}{x^2}\right)^{10}$ is 720, is (2019 Main, 10 Jan II)

- (a) 3 (b) $\sqrt{5}$ (c) $2\sqrt{2}$ (d) 4

15. If the third term in the binomial expansion of $(1 + x^{\log_2 x})^5$ equals 2560, then a possible value of x is (2019 Main, 10 Jan I)

- (a) $4\sqrt{2}$ (b) $\frac{1}{4}$ (c) $\frac{1}{8}$ (d) $2\sqrt{2}$

16. The coefficient of t^4 in the expansion of $\left(\frac{1-t^6}{1-t}\right)^3$ is

(2019 Main, 9 Jan II)

- (a) 12 (b) 10 (c) 15 (d) 14

90 Binomial Theorem

17. The sum of the coefficients of all odd degree terms in the expansion of $(x + \sqrt{x^3 - 1})^5 + (x - \sqrt{x^3 - 1})^5$, ($x > 1$) is (2018 Main)
 (a) -1 (b) 0 (c) 1 (d) 2
18. The value of $({}^{21}C_1 - {}^{10}C_1) + ({}^{21}C_2 - {}^{10}C_2) + ({}^{21}C_3 - {}^{10}C_3) + ({}^{21}C_4 - {}^{10}C_4) + \dots + ({}^{21}C_{10} - {}^{10}C_{10})$ is (2017 Main)
 (a) $2^{21} - 2^{11}$ (b) $2^{21} - 2^{10}$ (c) $2^{20} - 2^9$ (d) $2^{20} - 2^{10}$
19. If the number of terms in the expansion of $(1 - \frac{2}{x} + \frac{4}{x^2})^n$, $x \neq 0$, is 28, then the sum of the coefficients of all the terms in this expansion, is (2016 Main)
 (a) 64 (b) 2187 (c) 243 (d) 729
20. The sum of coefficients of integral powers of x in the binomial expansion $(1 - 2\sqrt{x})^{50}$ is (2015 Main)
 (a) $\frac{1}{2}(3^{50} + 1)$ (b) $\frac{1}{2}(3^{50})$ (c) $\frac{1}{2}(3^{50} - 1)$ (d) $\frac{1}{2}(2^{50} + 1)$
21. Coefficient of x^{11} in the expansion of $(1 + x^2)^4(1 + x^3)^7(1 + x^4)^{12}$ is (2014 Adv.)
 (a) 1051 (b) 1106 (c) 1113 (d) 1120
22. The term independent of x in expansion of $(\frac{x+1}{x^{2/3} - x^{1/3} + 1} - \frac{x-1}{x-x^{1/2}})^{10}$ is (2013 Main)
 (a) 4 (b) 120 (c) 210 (d) 310
23. Coefficient of t^{24} in $(1 + t^2)^{12}(1 + t^{12})(1 + t^{24})$ is (2003, 1M)
 (a) ${}^{12}C_6 + 3$ (b) ${}^{12}C_6 + 1$ (c) ${}^{12}C_6$ (d) ${}^{12}C_6 + 2$
24. In the binomial expansion of $(a - b)^n$, $n \geq 5$ the sum of the 5th and 6th terms is zero. Then, a/b equals (2001, 1M)
 (a) $\frac{n-5}{6}$ (b) $\frac{n-4}{5}$ (c) $\frac{5}{n-4}$ (d) $\frac{6}{n-5}$
25. If in the expansion of $(1 + x)^m(1 - x)^n$, the coefficients of x and x^2 are 3 and -6 respectively, then m is equal to (1999, 2M)
 (a) 6 (b) 9 (c) 12 (d) 24
26. The expression $[x + (x^3 - 1)^{1/2}]^5 + [x - (x^3 - 1)^{1/2}]^5$ is a polynomial of degree (1992, 2M)
 (a) 5 (b) 6 (c) 7 (d) 8
27. The coefficient of x^4 in $(\frac{x}{2} - \frac{3}{x^2})^{10}$ is (1983, 1M)
 (a) $\frac{405}{256}$ (b) $\frac{504}{259}$
 (c) $\frac{450}{263}$ (d) None of these
28. Given positive integers $r > 1$, $n > 2$ and the coefficient of $(3r)$ th and $(r + 2)$ th terms in the binomial expansion of $(1 + x)^{2n}$ are equal. Then, (1980, 2M)
 (a) $n = 2r$ (b) $n = 2r + 1$
 (c) $n = 3r$ (d) None of these

29. If the coefficients of x^3 and x^4 in the expansion of $(1 + ax + bx^2)(1 - 2x)^{18}$ in powers of x are both zero, then (a, b) is equal to

(a) $(16, \frac{251}{3})$ (b) $(14, \frac{251}{3})$ (c) $(14, \frac{272}{3})$ (d) $(16, \frac{272}{3})$

Fill in the Blanks

30. Let n be a positive integer. If the coefficients of 2nd, 3rd, and 4th terms in the expansion of $(1 + x)^n$ are in AP, then the value of n is... (1994, 2M)
31. If $(1 + ax)^n = 1 + 8x + 24x^2 + \dots$, then $a = \dots$ and $n = \dots$ (1983, 2M)
32. For any odd integer $n \geq 1$, $n^3 - (n-1)^3 + \dots + (-1)^{n-1}1^3 = \dots$
33. The larger of $99^{50} + 100^{50}$ and 101^{50} is ...

Analytical & Descriptive Questions

34. Prove that $\sum_{r=1}^k (-3)^{r-1} {}^3n C_{2r-1} = 0$, where $k = (3n)/2$ and n is an even positive integer. (1993, 5M)
35. If $\sum_{r=0}^{2n} a_r (x-2)^r = \sum_{r=0}^{2n} b_r (x-3)^r$ and $a_k = 1, \forall k \geq n$, then show that $b_n = {}^{2n+1}C_{n+1}$ (1992, 6M)
36. Find the sum of the series $\sum_{r=0}^n (-1)^r {}^n C_r \left[\frac{1}{2^r} + \frac{3^r}{2^{2r}} + \frac{7^r}{2^{3r}} + \frac{15^r}{2^{4r}} \dots \text{upto } m \text{ terms} \right]$. (1985, 5M)
37. Given, $s_n = 1 + q + q^2 + \dots + q^n$
 $S_n = 1 + \frac{q+1}{2} + \left(\frac{q+1}{2}\right)^2 + \dots + \left(\frac{q+1}{2}\right)^n, q \neq 1$
 Prove that ${}^{n+1}C_1 + {}^{n+1}C_2 s_1 + {}^{n+1}C_3 s_2 + \dots + {}^{n+1}C_{n+1} s_n = 2^n S_n$ (1984, 4M)

Integer & Numerical Answer Type Questions

38. The natural number m , for which the coefficient of x in the binomial expansion of $(x^m + \frac{1}{x^2})^{22}$ is 1540, is [2020 Main, 5 Sep II]
39. Let m be the smallest positive integer such that the coefficient of x^2 in the expansion of $(1 + x)^2 + (1 + x)^3 + \dots + (1 + x)^{49} + (1 + mx)^{50}$ is $(3n + 1) {}^{51}C_3$ for some positive integer n . Then, the value of n is (2016 Adv.)
40. The coefficient of x^9 in the expansion of $(1 + x)(1 + x^2)(1 + x^3) \dots (1 + x^{100})$ is (2015 Adv.)
41. The coefficients of three consecutive terms of $(1 + x)^{n+5}$ are in the ratio 5 : 10 : 14. Then, n is equal to (2013 Adv.)

Topic 2 Properties of Binomial Coefficient

Objective Questions I (Only one correct option)

1. Let $(x + 10)^{50} + (x - 10)^{50} = a_0 + a_1x + a_2x^2 + \dots + a_{50}x^{50}$, for all $x \in R$; then $\frac{a_2}{a_0}$ is equal to (2019 Main, 11 Jan II)

- (a) 12.25 (b) 12.50
(c) 12.00 (d) 12.75

2. The value of r for which ${}^{20}C_r {}^{20}C_0 + {}^{20}C_{r-1} {}^{20}C_1 + {}^{20}C_{r-2} {}^{20}C_2 + \dots + {}^{20}C_0 {}^{20}C_r$ is maximum, is (2019 Main, 11 Jan I)

- (a) 15 (b) 10
(c) 11 (d) 20

3. If the fractional part of the number $\frac{2^{403}}{15}$ is $\frac{k}{15}$, then k is equal to (2019 Main, 9 Jan I)

- (a) 14 (b) 6
(c) 4 (d) 8

4. For $r = 0, 1, \dots, 10$, if A_r, B_r and C_r denote respectively the coefficient of x^r in the expansions of $(1+x)^{10}, (1+x)^{20}$ and $(1+x)^{30}$. Then, $\sum_{r=1}^{10} A_r (B_{10}B_r - C_{10}A_r)$ is equal to

- (a) $B_{10} - C_{10}$ (b) $A_{10} (B_{10}^2 - C_{10}A_{10})$ (2010)
(c) 0 (d) $C_{10} - B_{10}$

5. $\binom{30}{0}\binom{30}{10} - \binom{30}{1}\binom{30}{11} + \binom{30}{2}\binom{30}{12} + \dots + \binom{30}{20}\binom{30}{30}$ is equal to (2005, 1M)

- (a) ${}^{30}C_{11}$ (b) ${}^{60}C_{10}$
(c) ${}^{30}C_{10}$ (d) ${}^{65}C_{55}$

6. If ${}^{n-1}C_r = (k^2 - 3) {}^nC_{r+1}$, then k belongs to (2004, 1M)

- (a) $(-\infty, -2]$ (b) $[2, \infty)$
(c) $[-\sqrt{3}, \sqrt{3}]$ (d) $(\sqrt{3}, 2]$

7. The sum $\sum_{i=0}^m \binom{10}{i} \binom{20}{m-i}$, where $\binom{p}{q} = 0$ if $p < q$, is maximum when m is equal to (2002, 1M)

- (a) 5 (b) 10
(c) 15 (d) 20

8. For $2 \leq r \leq n$, $\binom{n}{r} + 2\binom{n}{r-1} + \binom{n}{r-2}$ is equal to (2000, 2M)

- (a) $\binom{n+1}{r-1}$ (b) $2\binom{n+1}{r+1}$
(c) $2\binom{n+2}{r}$ (d) $\binom{n+2}{r}$

9. If $a_n = \sum_{r=0}^n \frac{1}{{}^nC_r}$, then $\sum_{r=0}^n \frac{r}{{}^nC_r}$ equals (1998, 2M)

- (a) $(n-1)a_n$ (b) na_n
(c) $\frac{1}{2}na_n$ (d) None of these

10. If C_r stands for nC_r , then the sum of the series

$$\frac{2 \binom{n}{2}! \binom{n}{2}!}{n!} [C_0^2 - 2C_1^2 + 3C_2^2 - \dots + (-1)^n(n+1)C_n^2],$$

where n is an even positive integer, is (1986, 2M)

- (a) $(-1)^{n/2}(n+2)$ (b) $(-1)^n(n+1)$
(c) $(-1)^{n/2}(n+1)$ (d) None of these

Objective Question II

(One or more than one correct option)

11. For non-negative integers s and r , let

$$\binom{s}{r} = \begin{cases} \frac{s!}{r!(s-r)!} & \text{if } r \leq s, \\ 0 & \text{if } r > s \end{cases}$$

For positive integers m and n , let

$$g(m, n) = \sum_{p=0}^{m+n} \frac{f(m, n, p)}{\binom{n+p}{p}}$$

where for any non-negative integer p ,

$$f(m, n, p) = \sum_{i=0}^p \binom{m}{i} \binom{n+i}{p} \binom{p+n}{p-i}. \quad (2020 Adv.)$$

Then which of the following statements is/are TRUE?

- (a) $g(m, n) = g(n, m)$ for all positive integers m, n
(b) $g(m, n+1) = g(m+1, n)$ for all positive integers m, n
(c) $g(2m, 2n) = 2g(m, n)$ for all positive integers m, n
(d) $g(2m, 2n) = (g(m, n))^2$ for all positive integers m, n

Integer & Numerical Answer Type Questions

12. Suppose $\det \begin{bmatrix} \sum_{k=0}^n k & \sum_{k=0}^n {}^nC_k k^2 \\ \sum_{k=0}^n {}^nC_k k & \sum_{k=0}^n {}^nC_k 3^k \end{bmatrix} = 0$ holds for some

positive integer n . Then $\sum_{k=0}^n \frac{{}^nC_k}{k+1}$ equals (2019 Adv.)

13. Let $X = ({}^{10}C_1)^2 + 2({}^{10}C_2)^2 + 3({}^{10}C_3)^2 + \dots + 10({}^{10}C_{10})^2$, where ${}^{10}C_r, r \in \{1, 2, \dots, 10\}$ denote binomial coefficients. Then, the value of $\frac{1}{1430} X$ is (2018 Adv.)

Fill in the Blank

14. The sum of the coefficients of the polynomial $(1+x-3x^2)^{2163}$ is (1982, 2M)

Analytical & Descriptive Questions

15. Prove that

$$2^k \binom{n}{0} \binom{n}{k} - 2^{k-1} \binom{n}{1} \binom{n-1}{k-1} + 2^{k-2} \binom{n}{2} \binom{n-2}{k-2} - \dots + (-1)^k \binom{n}{k} \binom{n-k}{0} = \binom{n}{k} \quad (2003, 4 M)$$

92 Binomial Theorem

16. For any positive integers m, n (with $n \geq m$),

If $\binom{n}{m} = {}^n C_m$. Prove that

$$\binom{n}{m} + \binom{n-1}{m} + \binom{n-2}{m} + \dots + \binom{m}{m} = \binom{n+1}{m+1}$$

or

Prove that

$$\binom{n}{m} + 2\binom{n-1}{m} + 3\binom{n-2}{m} + \dots + (n-m+1)\binom{m}{m} = \binom{n+2}{m+2} \quad (\text{IIT JEE 2000, 6M})$$

17. Prove that $\frac{3!}{2(n+3)} = \sum_{r=0}^n (-1)^r \binom{n}{r+3} C_r$. (1997C, 5M)

18. If n is a positive integer and

$$(1+x+x^2)^n = a_0 + a_1x + \dots + a_{2n}x^{2n}.$$

Then, show that, $a_0^2 - a_1^2 + \dots + a_{2n}^2 = a_n$. (1994, 5M)

19. Prove that $C_0 - 2^2 \cdot C_1 + 3^2 \cdot C_2 - \dots + (-1)^n (n+1)^2 C_n = 0$, $n > 2$, where $C_r = {}^n C_r$. (1989, 5M)

20. If $(1+x)^n = C_0 + C_1x + C_2x^2 + \dots + C_nx^n$, then show that the sum of the products of the C_i 's taken two at a time represented by $\sum \sum C_i C_j$ is equal to

$$0 \leq i < j \leq n \quad 2^{2n-1} - \frac{(2n)!}{2(n!)^2}. \quad (1983, 3M)$$

21. Prove that $C_1^2 - 2 \cdot C_2^2 + 3 \cdot C_3^2 - \dots - 2n \cdot C_{2n}^2 = (-1)^n n \cdot C_n$ (1979, 4M)

22. Prove that $({}^{2n}C_0)^2 - ({}^{2n}C_1)^2 + ({}^{2n}C_2)^2 - \dots + ({}^{2n}C_{2n})^2 = (-1)^n \cdot 2^n C_n$. (1978, 4M)

Answers

Topic 1

- | | | | |
|--------------------|---------------|---------|---------|
| 1. (c) | 2. (b) | 3. (a) | 4. (a) |
| 5. (c) | 6. (d) | 7. (c) | 8. (d) |
| 9. (c) | 10. (d) | 11. (c) | 12. (c) |
| 13. (b) | 14. (d) | 15. (b) | 16. (c) |
| 17. (d) | 18. (d) | 19. (d) | 20. (a) |
| 21. (c) | 22. (c) | 23. (d) | 24. (b) |
| 25. (c) | 26. (c) | 27. (a) | 28. (a) |
| 29. (d) | 30. ($n=7$) | | |
| 31. ($a=2, n=4$) | | | |

32. $\frac{1}{4}(n+1)^2(2n-1)$

33. $(101)^{50}$ 36. $\left[\frac{2^{mn}-1}{2^{mn}(2^n-1)} \right]$

38. (13) 39. (5) 40. (8) 41. ($n=6$)

Topic 2

- | | | | |
|-----------|----------|-------------|------------|
| 1. (a) | 2. (d) | 3. (d) | 4. (d) |
| 5. (c) | 6. (d) | 7. (c) | 8. (d) |
| 9. (c) | 10. (a) | 11. (a,b,d) | 12. (6.20) |
| 13. (646) | 14. (-1) | | |

Hints & Solutions

Topic 1 Binomial Expansion and General Term

1. Since, the general term in the expansion of binomial

$\left(\sqrt{x} - \frac{k}{x^2}\right)^{10}$ is

$$T_{r+1} = {}^{10}C_r x^{\left(\frac{10-r}{2}\right)} (-k)^r x^{-2r} = {}^{10}C_r (-k)^r x^{\frac{10-5r}{2}}$$

\therefore Term is constant, so $r=2$.

$$\therefore {}^{10}C_2 (-k)^2 = 405 \Rightarrow \frac{10 \times 9}{2} k^2 = 405$$

$$\Rightarrow k^2 = 9 \Rightarrow |k| = 3$$

2. Given expression is

$$\begin{aligned} (x + \sqrt{x^2-1})^6 + (x - \sqrt{x^2-1})^6 \\ = 2 [{}^6C_0 x^6 + {}^6C_2 x^4 (x^2-1) + {}^6C_4 x^2 (x^2-1)^2 \\ + {}^6C_6 (x^2-1)^3] \end{aligned}$$

The coefficients of x^4 in above expansion

$$\alpha = 2 [{}^6C_2(-1) + {}^6C_4 \cdot 2 C_1(-1) + {}^6C_6 \cdot 3 C_1(-1)]$$

$$= 2 [-15 - (15 \times 2) - (1 \times 3)] = -96$$

and the coefficient of x^2 in the expansion

$$\beta = 2 [{}^6C_4 \cdot 4 C_0 + {}^6C_6 \cdot 3 C_2] = 2 [15 + 3] = 36$$

$$\therefore \alpha - \beta = -96 - 36 = -132$$

Hence, option (b) is correct.

3. Given expression is $(1+x)(1-x)^{10}(1+x+x^2)^9$

$$= (1+x)(1-x)[(1-x)(1+x+x^2)]^9$$

$$= (1-x^2)(1-x^3)^9$$

Now, coefficient of x^{18} in the product

$$(1+x)(1-x)^{10}(1+x+x^2)^9$$

$$= \text{coefficient of } x^{18} \text{ in the product } (1-x^2)(1-x^3)^9$$

$$= \text{coefficient of } x^{18} \text{ in } (1-x^3)^9$$

$$- \text{coefficient of } x^{16} \text{ in } (1-x^3)^9$$

Since, $(r+1)^{\text{th}}$ term in the expansion of

$$(1-x^3)^9 \text{ is } {}^9C_r (-x^3)^r = {}^9C_r (-1)^r x^{3r}$$

Now, for x^{18} , $3r = 18 \Rightarrow r = 6$

and for x^{16} , $3r = 16 \Rightarrow r = \frac{16}{3} \notin N$.

\therefore Required coefficient is ${}^9C_6 = \frac{9!}{6!3!} = \frac{9 \times 8 \times 7}{3 \times 2} = 84$

4. Given expression is $(1 + ax + bx^2)(1 - 3x)^{15}$. In the expansion of binomial $(1 - 3x)^{15}$, the $(r + 1)$ th term is

$$T_{r+1} = {}^{15}C_r (-3x)^r = {}^{15}C_r (-3)^r x^r$$

Now, coefficient of x^2 , in the expansion of $(1 + ax + bx^2)(1 - 3x)^{15}$ is

$${}^{15}C_2(-3)^2 + a {}^{15}C_1(-3)^1 + b {}^{15}C_0(-3)^0 = 0 \text{ (given)}$$

$$\Rightarrow (105 \times 9) - 45a + b = 0 \Rightarrow 45a - b = 945 \quad \dots(i)$$

Similarly, the coefficient of x^3 , in the expansion of $(1 + ax + bx^2)(1 - 3x)^{15}$ is

$${}^{15}C_3(-3)^3 + a {}^{15}C_2(-3)^2 + b {}^{15}C_1(-3)^1 = 0 \text{ (given)}$$

$$\Rightarrow -12285 + 945a - 45b = 0$$

$$\Rightarrow 63a - 3b = 819 \Rightarrow 21a - b = 273 \quad \dots(ii)$$

From Eqs. (i) and (ii), we get

$$24a = 672 \Rightarrow a = 28$$

So, $b = 315 \Rightarrow (a, b) = (28, 315)$

5. **Key Idea** Use the general term (or $(r + 1)$ th term) in the expansion of binomial $(a + b)^n$
i.e. $T_{r+1} = {}^nC_r a^{n-r} b^r$

Let a binomial $\left(2x^2 - \frac{3}{x^2}\right)^6$, it's $(r + 1)$ th term

$$= T_{r+1} = {}^6C_r (2x^2)^{6-r} \left(-\frac{3}{x^2}\right)^r$$

$$= {}^6C_r (-3)^r (2)^{6-r} x^{12-2r-2r}$$

$$= {}^6C_r (-3)^r (2)^{6-r} x^{12-4r} \quad \dots(i)$$

Now, the term independent of x in the expansion of $\left(\frac{1}{60} - \frac{x^8}{81}\right) \left(2x^2 - \frac{3}{x^2}\right)^6$

= the term independent of x in the expansion of $\frac{1}{60} \left(2x^2 - \frac{3}{x^2}\right)^6$ + the term independent of x in the

expansion of $-\frac{x^8}{81} \left(2x^2 - \frac{3}{x^2}\right)^6$

$$= \frac{{}^6C_3}{60} (-3)^3 (2)^{6-3} x^{12-4(3)} \quad [\text{put } r = 3]$$

$$+ \left(-\frac{1}{81}\right) {}^6C_5 (-3)^5 (2)^{6-5} x^{12-4(5)} x^8 \quad [\text{put } r = 5]$$

$$= \frac{1}{3} (-3)^3 2^3 + \frac{3^5 \times 2(6)}{81} = 36 - 72 = -36$$

6. Given binomial is $\left(x^2 + \frac{1}{x^3}\right)^n$, its $(r + 1)$ th term, is

$$T_{r+1} = {}^nC_r (x^2)^{n-r} \left(\frac{1}{x^3}\right)^r = {}^nC_r x^{2n-2r} \frac{1}{x^{3r}}$$

$$= {}^nC_r x^{2n-2r-3r} = {}^nC_r x^{2n-5r}$$

For the coefficient of x ,

$$2n - 5r = 1 \Rightarrow 2n = 5r + 1 \quad \dots(i)$$

As coefficient of x is given as ${}^nC_{23}$, then either $r = 23$ or $n - r = 23$.

If $r = 23$, then from Eq. (i), we get

$$2n = 5(23) + 1$$

$$\Rightarrow 2n = 115 + 1 \Rightarrow 2n = 116 \Rightarrow n = 58.$$

If $n - r = 23$, then from Eq. (i) on replacing the value of 'r', we get $2n = 5(n - 23) + 1$

$$\Rightarrow 2n = 5n - 115 + 1 \Rightarrow 3n = 114 \Rightarrow n = 38$$

So, the required smallest natural number $n = 38$.

7. **Key Idea** Use general term of Binomial expansion $(x + a)^n$ i.e.

$$T_{r+1} = {}^nC_r x^{n-r} a^r$$

Given binomial is $(x + 1)^n$, whose general term, is $T_{r+1} = {}^nC_r x^r$

According to the question, we have

$${}^nC_{r-1} : {}^nC_r : {}^nC_{r+1} = 2 : 15 : 70$$

Now, $\frac{{}^nC_{r-1}}{{}^nC_r} = \frac{2}{15}$

$$\Rightarrow \frac{(r-1)!(n-r+1)!}{n!} = \frac{2}{15}$$

$$\frac{r!(n-r)!}{r!(n-r)!} = \frac{2}{15}$$

$$\Rightarrow \frac{r}{n-r+1} = \frac{2}{15} \Rightarrow 15r = 2n - 2r + 2$$

$$\Rightarrow 2n - 17r + 2 = 0 \quad \dots(i)$$

Similarly, $\frac{{}^nC_r}{{}^nC_{r+1}} = \frac{15}{70} \Rightarrow \frac{\frac{n!}{r!(n-r)!}}{\frac{n!}{(r+1)!(n-r-1)!}} = \frac{3}{14}$

$$\Rightarrow \frac{r+1}{n-r} = \frac{3}{14} \Rightarrow 14r + 14 = 3n - 3r$$

$$\Rightarrow 3n - 17r - 14 = 0 \quad \dots(ii)$$

On solving Eqs. (i) and (ii), we get

$$n - 16 = 0 \Rightarrow n = 16 \text{ and } r = 2$$

Now, the average = $\frac{{}^{16}C_1 + {}^{16}C_2 + {}^{16}C_3}{3}$

$$= \frac{16 + 120 + 560}{3} = \frac{696}{3} = 232$$

8. Given binomial is $\left(\frac{2}{x} + x^{\log_8 x}\right)^6$

Since, general term in the expansion of $(x + a)^n$ is $T_{r+1} = {}^nC_r x^{n-r} a^r$

$$\therefore T_4 = T_{3+1} = {}^6C_3 \left(\frac{2}{x}\right)^{6-3} (x^{\log_8 x})^3 = 20 \times 8^7 \text{ (given)}$$

$$\Rightarrow 20 \left(\frac{2}{x}\right)^3 x^{3 \log_8 x} = 20 \times 8^7 \quad [\because {}^6C_3 = 20]$$

$$\Rightarrow 2^3 x^{[3(\log_8 x) - 3]} = (2^3)^7 \Rightarrow x^{\left(\frac{3}{8} \log_2 x - 3\right)} = (2^3)^6$$

94 Binomial Theorem

$$\left[\because \log_{a^n}(x) = \frac{1}{n} \log_a x \text{ for } x > 0; a > 0, \neq 1 \right]$$

$$\Rightarrow x^{(\log_2 x - 3)} = 2^{18}$$

On taking \log_2 both sides, we get

$$\begin{aligned} & (\log_2 x - 3) \log_2 x = 18 \\ \Rightarrow & (\log_2 x)^2 - 3 \log_2 x - 18 = 0 \\ \Rightarrow & (\log_2 x)^2 - 6 \log_2 x + 3 \log_2 x - 18 = 0 \\ \Rightarrow & \log_2 x (\log_2 x - 6) + 3 (\log_2 x - 6) = 0 \\ \Rightarrow & (\log_2 x - 6) (\log_2 x + 3) = 0 \\ \Rightarrow & \log_2 x = -3, 6 \\ \Rightarrow & x = 2^{-3}, 2^6 \Rightarrow x = \frac{1}{8}, 8^2 \end{aligned}$$

9. Given binomial is $\left(\sqrt{x^{\frac{1}{1+\log_{10} x}} + x^{\frac{1}{12}}} \right)^6$

Since, the fourth term in the given expansion is 200.

$$\begin{aligned} \therefore {}^6C_3 \left(x^{\frac{1}{1+\log_{10} x}} \right)^{\frac{3}{2}} \left(x^{\frac{1}{12}} \right)^3 &= 200 \\ \Rightarrow 20 \times x^{\left[\frac{3}{2(1+\log_{10} x)} + \frac{1}{4} \right]} &= 200 \Rightarrow x^{\frac{3}{2(1+\log_{10} x)} + \frac{1}{4}} = 10 \\ \Rightarrow \left[\frac{3}{2(1+\log_{10} x)} + \frac{1}{4} \right] \log_{10} x &= 1 \\ & \text{[applying } \log_{10} \text{ both sides]} \\ \Rightarrow [6 + (1 + \log_{10} x)] \log_{10} x &= 4(1 + \log_{10} x) \\ \Rightarrow (7 + \log_{10} x) \log_{10} x &= 4 + 4 \log_{10} x \\ \Rightarrow t^2 + 7t = 4 + 4t & \quad \text{[let } \log_{10} x = t] \\ \Rightarrow t^2 + 3t - 4 = 0 \\ \Rightarrow t = 1, -4 = \log_{10} x \\ \Rightarrow x = 10, 10^{-4} \\ \text{Since, } x > 1 & \quad x = 10 \end{aligned}$$

10.

Key Idea Use formula :

$$(a+b)^n + (a-b)^n = 2[{}^nC_0 a^n + {}^nC_2 a^{n-2} b^2 + {}^nC_4 a^{n-4} b^4 + \dots]$$

$$\begin{aligned} \text{Given expression is } & (x + \sqrt{x^3 - 1})^6 + (x - \sqrt{x^3 - 1})^6 \\ = & 2[{}^6C_0 x^6 + {}^6C_2 x^4 (\sqrt{x^3 - 1})^2 \\ & + {}^6C_4 x^2 (\sqrt{x^3 - 1})^4 + {}^6C_6 (\sqrt{x^3 - 1})^6] \\ & \quad \quad \quad \{ \because (a+b)^n + (a-b)^n \\ = & 2[{}^nC_0 a^n + {}^nC_2 a^{n-2} b^2 + {}^nC_4 a^{n-4} b^4 + \dots] \} \\ = & 2[{}^6C_0 x^6 + {}^6C_2 x^4 (x^3 - 1) + {}^6C_4 x^2 (x^3 - 1)^2 + {}^6C_6 (x^3 - 1)^3] \end{aligned}$$

The sum of the terms with even power of x

$$\begin{aligned} = & 2[{}^6C_0 x^6 + {}^6C_2 (-x^4) + {}^6C_4 x^8 + {}^6C_4 x^2 + {}^6C_6 (-1 - 3x^6)] \\ = & 2[{}^6C_0 x^6 - {}^6C_2 x^4 + {}^6C_4 x^8 + {}^6C_4 x^2 - 1 - 3x^6] \end{aligned}$$

Now, the required sum of the coefficients of even powers of x in

$$\begin{aligned} & (x + \sqrt{x^3 - 1})^6 + (x - \sqrt{x^3 - 1})^6 \\ & = 2[{}^6C_0 - {}^6C_2 + {}^6C_4 + {}^6C_4 - 1 - 3] \\ & = 2[1 - 15 + 15 + 15 - 1 - 3] = 2(15 - 3) = 24 \end{aligned}$$

11. The general term in the binomial expansion of $(a+b)^n$ is $T_{r+1} = {}^nC_r a^{n-r} b^r$.

So, the general term in the binomial expansion of $(7^{1/5} - 3^{1/10})^{60}$ is

$$\begin{aligned} T_{r+1} &= {}^{60}C_r (7^{1/5})^{60-r} (-3^{1/10})^r \\ &= {}^{60}C_r 7^{\frac{60-r}{5}} (-1)^r 3^{\frac{r}{10}} = (-1)^r {}^{60}C_r 7^{12-\frac{r}{5}} 3^{\frac{r}{10}} \end{aligned}$$

The possible non-negative integral values of ' r ' for which $\frac{r}{5}$ and $\frac{r}{10}$ are integer, where $r \leq 60$, are $r = 0, 10, 20, 30, 40, 50, 60$.

\therefore There are 7 rational terms in the binomial expansion and remaining $61 - 7 = 54$ terms are irrational terms.

12. Since, r th term from the end in the expansion of a binomial $(x+a)^n$ is same as the $(n-r+2)$ th term from the beginning in the expansion of same binomial.

$$\therefore \text{Required ratio} = \frac{T_5}{T_{10-5+2}} = \frac{T_5}{T_7} = \frac{T_{4+1}}{T_{6+1}}$$

$$\begin{aligned} \Rightarrow \frac{T_5}{T_{10-5+2}} &= \frac{{}^{10}C_4 (2^{1/3})^{10-4} \left(\frac{1}{2(3)^{1/3}} \right)^4}{{}^{10}C_6 (2^{1/3})^{10-6} \left(\frac{1}{2(3)^{1/3}} \right)^6} \\ & \quad \quad \quad \{ \because T_{r+1} = {}^nC_r x^{n-r} a^r \} \\ &= \frac{2^{63} (2(3)^{1/3})^6}{{}^{10}C_6 (2(3)^{1/3})^4} \quad \{ \because {}^{10}C_4 = {}^{10}C_6 \} \\ &= 2^{63-4/3} (2(3)^{1/3})^{6-4} \\ &= 2^{23} \cdot 2^2 \cdot 3^{2/3} \\ &= 4(6)^{23} = 4(36)^{1/3} \end{aligned}$$

So, the required ratio is $4(36)^{1/3} : 1$.

13. In the expansion of $\left(\frac{x^3}{3} + \frac{3}{x} \right)^8$, the middle term is T_{4+1} .

[\because Here, $n = 8$, which is even, therefore middle term = $\left(\frac{n+2}{2} \right)$ th term]

$$\begin{aligned} \therefore 5670 &= {}^8C_4 \left(\frac{x^3}{3} \right)^4 \left(\frac{3}{x} \right)^4 = \frac{8 \cdot 7 \cdot 6 \cdot 5}{1 \cdot 2 \cdot 3 \cdot 4} x^8 \\ & \quad \quad \quad \left[\because T_{r+1} = {}^8C_r \left(\frac{x^3}{3} \right)^{8-r} \left(\frac{3}{x} \right)^r \right] \end{aligned}$$

$$\Rightarrow x^8 = 3^4 \Rightarrow x = \pm \sqrt{3}$$

So, sum of all values of x i.e. $+\sqrt{3}$ and $-\sqrt{3} = 0$

14. The general term in the expansion of binomial expression $(a+b)^n$ is $T_{r+1} = {}^nC_r a^{n-r} b^r$, so the general term in the expansion of binomial expression

$$x^2 \left(\sqrt{x + \frac{\lambda}{x^2}} \right)^{10} \text{ is}$$

$$T_{r+1} = x^2 \left({}^{10}C_r (\sqrt{x})^{10-r} \left(\frac{\lambda}{x^2} \right)^r \right) = {}^{10}C_r x^2 \cdot x^{\frac{10-r}{2}} \lambda^r x^{-2r}$$

$$= {}^{10}C_r \lambda^r x^{2 + \frac{10-r}{2} - 2r}$$

Now, for the coefficient of x^2 , put $2 + \frac{10-r}{2} - 2r = 2$

$$\Rightarrow \frac{10-r}{2} - 2r = 0$$

$$\Rightarrow 10 - r = 4r \Rightarrow r = 2$$

So, the coefficient of x^2 is ${}^{10}C_2 \lambda^2 = 720$ [given]

$$\Rightarrow \frac{10!}{2!8!} \lambda^2 = 720 \Rightarrow \frac{10 \cdot 9 \cdot 8!}{2 \cdot 8!} \lambda^2 = 720$$

$$\Rightarrow 45 \lambda^2 = 720$$

$$\Rightarrow \lambda^2 = 16 \Rightarrow \lambda = \pm 4$$

$$\therefore \lambda = 4 \quad [\lambda > 0]$$

15. The $(r + 1)$ th term in the expansion of $(a + x)^n$ is given by $T_{r+1} = {}^nC_r a^{n-r} x^r$

$\therefore 3^{\text{rd}}$ term in the expansion of $(1 + x^{\log_2 x})^5$ is

$${}^5C_2 (1)^{5-2} (x^{\log_2 x})^2$$

$$\Rightarrow {}^5C_2 (1)^{5-2} (x^{\log_2 x})^2 = 2560 \text{ (given)}$$

$$\Rightarrow 10 (x^{\log_2 x})^2 = 2560$$

$$\Rightarrow x^{2 \log_2 x} = 256$$

$$\Rightarrow \log_2 x^{2 \log_2 x} = \log_2 256$$

$$\Rightarrow 2(\log_2 x)(\log_2 x) = 8 \quad (\because \log_2 256 = \log_2 2^8 = 8)$$

$$(\log_2 x)^2 = 4$$

$$\Rightarrow \log_2 x = \pm 2$$

$$\Rightarrow \log_2 x = 2 \text{ or } \log_2 x = -2$$

$$\Rightarrow x = 4 \text{ or } x = 2^{-2} = \frac{1}{4}$$

16. Clearly, $\left(\frac{1-t^6}{1-t} \right)^3 = (1-t^6)^3 (1-t)^{-3}$

\therefore Coefficient of t^4 in $(1-t^6)^3 (1-t)^{-3}$

$$= \text{Coefficient of } t^4 \text{ in } (1-t^{18} - 3t^6 + 3t^{12})(1-t)^{-3}$$

$$= \text{Coefficient of } t^4 \text{ in } (1-t)^{-3}$$

$$= {}^{3+4-1}C_4 = {}^6C_4 = 15$$

$$(\because \text{coefficient of } x^r \text{ in } (1-x)^{-n} = {}^{n+r-1}C_r)$$

17. **Key Idea** Use formula :

$$= (a+b)^n + (a-b)^n$$

$$= 2({}^nC_0 a^n + {}^nC_2 a^{n-2} b^2 + {}^nC_4 a^{n-4} b^4 + \dots)$$

We have, $(x + \sqrt{x^3 - 1})^5 + (x - \sqrt{x^3 - 1})^5, x > 1$

$$= 2({}^5C_0 x^5 + {}^5C_2 x^3 (\sqrt{x^3 - 1})^2 + {}^5C_4 x (\sqrt{x^3 - 1})^4)$$

$$= 2(x^5 + 10x^3 (x^3 - 1) + 5x(x^3 - 1)^2)$$

$$= 2(x^5 + 10x^6 - 10x^3 + 5x^7 - 10x^4 + 5x)$$

Sum of coefficients of all odd degree terms is

$$2(1 - 10 + 5 + 5) = 2$$

18. $({}^{21}C_1 - {}^{10}C_1) + ({}^{21}C_2 - {}^{10}C_2) + ({}^{21}C_3 - {}^{10}C_3)$
 $\quad \quad \quad + \dots + ({}^{21}C_{10} - {}^{10}C_{10})$

$$= ({}^{21}C_1 + {}^{21}C_2 + \dots + {}^{21}C_{10}) - ({}^{10}C_1 + {}^{10}C_2 + \dots + {}^{10}C_{10})$$

$$= \frac{1}{2} ({}^{21}C_1 + {}^{21}C_2 + \dots + {}^{21}C_{20}) - (2^{10} - 1)$$

$$= \frac{1}{2} ({}^{21}C_1 + {}^{21}C_2 + \dots + {}^{21}C_{21} - 1) - (2^{10} - 1)$$

$$= \frac{1}{2} (2^{21} - 2) - (2^{10} - 1) = 2^{20} - 1 - 2^{10} + 1 = 2^{20} - 2^{10}$$

19. Clearly, number of terms in the expansion of

$$\left(1 - \frac{2}{x} + \frac{4}{x^2} \right)^n \text{ is } \frac{(n+2)(n+1)}{2} \text{ or } {}^{n+2}C_2$$

[assuming $\frac{1}{x}$ and $\frac{1}{x^2}$ distinct]

$$\therefore \frac{(n+2)(n+1)}{2} = 28$$

$$\Rightarrow (n+2)(n+1) = 56 = (6+1)(6+2) \Rightarrow n = 6$$

$$\text{Hence, sum of coefficients} = (1 - 2 + 4)^6 = 3^6 = 729$$

Note As $\frac{1}{x}$ and $\frac{1}{x^2}$ are functions of same variables, therefore

number of dissimilar terms will be $2n + 1$, i.e. odd, which is not possible. Hence, it contains error.

20. Let T_{r+1} be the general term in the expansion of $(1 - 2\sqrt{x})^{50}$

$$\therefore T_{r+1} = {}^{50}C_r (1)^{50-r} (-2x^{1/2})^r = {}^{50}C_r 2^r x^{r/2} (-1)^r$$

For the integral power of x , r should be even integer.

$$\therefore \text{Sum of coefficients} = \sum_{r=0}^{25} {}^{50}C_{2r} (2)^{2r}$$

$$= \frac{1}{2} [(1+2)^{50} + (1-2)^{50}] = \frac{1}{2} (3^{50} + 1)$$

Alternate Solution

We have,

$$(1 - 2\sqrt{x})^{50} = C_0 - C_1 2\sqrt{x} + C_2 (2\sqrt{x})^2 + \dots + C_{50} (2\sqrt{x})^{50} \dots \text{(i)}$$

$$(1 + 2\sqrt{x})^{50} = C_0 + C_1 2\sqrt{x} + C_2 (2\sqrt{x})^2 + \dots + C_{50} (2\sqrt{x})^{50} \dots \text{(ii)}$$

On adding Eqs. (i) and (ii), we get

$$(1 - 2\sqrt{x})^{50} + (1 + 2\sqrt{x})^{50}$$

$$= 2 [C_0 + C_2 (2\sqrt{x})^2 + \dots + C_{50} (2\sqrt{x})^{50}] \dots \text{(iii)}$$

$$\Rightarrow \frac{(1 - 2\sqrt{x})^{50} + (1 + 2\sqrt{x})^{50}}{2}$$

$$= C_0 + C_2 (2\sqrt{x})^2 + \dots + C_{50} (2\sqrt{x})^{50}$$

On putting $x = 1$, we get

$$\frac{(1 - 2\sqrt{1})^{50} + (1 + 2\sqrt{1})^{50}}{2} = C_0 + C_2 + \dots + C_{50} (2)^{50}$$

$$\Rightarrow \frac{(-1)^{50} + (3)^{50}}{2} = C_0 + C_2 (2)^2 + \dots + C_{50} (2)^{50}$$

$$\Rightarrow \frac{1 + 3^{50}}{2} = C_0 + C_2 (2)^2 + \dots + C_{50} (2)^{50}$$

21. Coefficient of x^r in $(1 + x)^n$ is nC_r .

In this type of questions, we find different composition of terms where product will give us x^{11} .

Now, consider the following cases for x^{11} in $(1 + x^2)^4 (1 + x^3)^7 (1 + x^4)^{12}$.

96 Binomial Theorem

Coefficient of $x^0 x^3 x^8$; Coefficient of $x^2 x^9 x^0$
 Coefficient of $x^4 x^3 x^4$; Coefficient of $x^8 x^3 x^0$
 $= {}^4C_0 \times {}^7C_1 \times {}^{12}C_2 + {}^4C_1 \times {}^7C_3 \times {}^{12}C_0 + {}^4C_2 \times {}^7C_1$
 $\times {}^{12}C_1 + {}^4C_4 \times {}^7C_1 \times {}^{12}C_0$
 $= 462 + 140 + 504 + 7 = 1113$

22. $\left[\frac{x+1}{x^{2/3} - x^{1/3} + 1} - \frac{(x-1)}{x - x^{1/2}} \right]^{10}$
 $= \left[\frac{(x^{1/3})^3 + 1^3 - \{(\sqrt{x})^2 - 1\}}{x^{2/3} - x^{1/3} + 1 - \sqrt{x}(\sqrt{x}-1)} \right]^{10}$
 $= \left[\frac{(x^{1/3} + 1)(x^{2/3} + 1 - x^{1/3}) - \{(\sqrt{x})^2 - 1\}}{x^{2/3} - x^{1/3} + 1 - \sqrt{x}(\sqrt{x}-1)} \right]^{10}$
 $= \left[(x^{1/3} + 1) - \frac{(\sqrt{x} + 1)}{\sqrt{x}} \right]^{10} = (x^{1/3} - x^{-1/2})^{10}$

\therefore The general term is

$$T_{r+1} = {}^{10}C_r (x^{1/3})^{10-r} (-x^{-1/2})^r = {}^{10}C_r (-1)^r x^{\frac{10-r}{3} - \frac{r}{2}}$$

For independent of x , put

$$\frac{10-r}{3} - \frac{r}{2} = 0 \Rightarrow 20 - 2r - 3r = 0$$

$$\Rightarrow 20 = 5r \Rightarrow r = 4$$

$$\therefore T_5 = {}^{10}C_4 = \frac{10 \times 9 \times 8 \times 7}{4 \times 3 \times 2 \times 1} = 210$$

23. Here, Coefficient of t^{24} in $\{(1+t^2)^{12}(1+t^{12})(1+t^{24})\}$
 $=$ Coefficient of t^{24} in $\{(1+t^2)^{12} \cdot (1+t^{12}+t^{24}+t^{36})\}$
 $=$ Coefficient of t^{24} in $\{(1+t^2)^{12} + t^{12}(1+t^2)^{12} + t^{24}(1+t^2)^{12}\}$;
 [neglecting $t^{36}(1+t^2)^{12}$]
 $=$ Coefficient of $t^{24} = ({}^{12}C_{12} + {}^{12}C_6 + {}^{12}C_0) = 2 + {}^{12}C_6$

24. Given, $T_5 + T_6 = 0$
 $\Rightarrow {}^nC_4 a^{n-4} b^4 - {}^nC_5 a^{n-5} b^5 = 0$
 $\Rightarrow {}^nC_4 a^{n-4} b^4 = {}^nC_5 a^{n-5} b^5 \Rightarrow \frac{a}{b} = \frac{{}^nC_5}{{}^nC_4} = \frac{n-4}{5}$

25. $(1+x)^m(1-x)^n = \left[1 + mx + \frac{m(m-1)}{2}x^2 + \dots \right]$
 $\left[1 - nx + \frac{n(n-1)}{2}x^2 - \dots \right]$
 $= 1 + (m-n)x + \left[\frac{m(m-1)}{2} + \frac{n(n-1)}{2} - mn \right]x^2 + \dots$

term containing power of $x \geq 3$.

Now, $m - n = 3$... (i)
 [\because coefficient of $x = 3$, given]

and $\frac{1}{2}m(m-1) + \frac{1}{2}n(n-1) - mn = -6$

$$\Rightarrow m(m-1) + n(n-1) - 2mn = -12$$

$$\Rightarrow m^2 - m + n^2 - n - 2mn = -12$$

$$\Rightarrow (m-n)^2 - (m+n) = -12$$

$$\Rightarrow m + n = 9 + 12 = 21$$
 ... (ii)

On solving Eqs. (i) and (ii), we get $m = 12$

26. We know that,

$$(a+b)^5 + (a-b)^5 = {}^5C_0 a^5 + {}^5C_1 a^4 b + {}^5C_2 a^3 b^2$$

$$+ {}^5C_3 a^2 b^3 + {}^5C_4 a b^4 + {}^5C_5 b^5 + {}^5C_0 a^5 - {}^5C_1 a^4 b$$

$$+ {}^5C_2 a^3 b^2 - {}^5C_3 a^2 b^3 + {}^5C_4 a b^4 - {}^5C_5 b^5$$

$$= 2[a^5 + 10a^3 b^2 + 5ab^4]$$

$$\therefore [x + (x^3 - 1)^{1/2}]^5 + [x - (x^3 - 1)^{1/2}]^5$$

$$= 2[x^5 + 10x^3(x^3 - 1) + 5x(x^3 - 1)^2]$$

Therefore, the given expression is a polynomial of degree 7.

27. The general term in $\left(\frac{x}{2} - \frac{3}{x^2}\right)^{10}$ is

$$t_{r+1} = (-1)^r {}^{10}C_r \left(\frac{x}{2}\right)^{10-r} \left(\frac{3}{x^2}\right)^r = (-1)^r {}^{10}C_r \cdot \frac{3^r}{2^{10-r}} \cdot x^{10-3r}$$

For coefficient of x^4 , we put $10 - 3r = 4$

$$\Rightarrow 3r = 6$$

$$\Rightarrow r = 2$$

$$\therefore \text{Coefficient of } x^4 \text{ in } \left(\frac{x}{2} - \frac{3}{x^2}\right)^{10} = (-1)^2 \cdot {}^{10}C_2 \cdot \frac{3^2}{2^8}$$

$$= \frac{45 \times 9}{256} = \frac{405}{256}$$

28. In the expansion $(1+x)^{2n}$, $t_{3r} = {}^{2n}C_{3r-1} (x)^{3r-1}$

and $t_{r+2} = {}^{2n}C_{r+1} (x)^{r+1}$

Since, binomial coefficients of t_{3r} and t_{r+2} are equal.

$$\therefore {}^{2n}C_{3r-1} = {}^{2n}C_{r+1}$$

$$\Rightarrow 3r - 1 = r + 1 \quad \text{or} \quad 2n = (3r - 1) + (r + 1)$$

$$\Rightarrow 2r = 2 \quad \text{or} \quad 2n = 4r$$

$$\Rightarrow r = 1 \quad \text{or} \quad n = 2r$$

But $r > 1$

\therefore We take, $n = 2r$

29. To find the coefficient of x^3 and x^4 , use the formula of coefficient of x^r in $(1-x)^n$ is $(-1)^r {}^nC_r$, and then simplify.

In expansion of $(1+ax+bx^2)(1-2x)^{18}$.

$$\text{Coefficient of } x^3 = \text{Coefficient of } x^3 \text{ in } (1-2x)^{18}$$

$$+ \text{Coefficient of } x^2 \text{ in } a(1-2x)^{18}$$

$$+ \text{Coefficient of } x \text{ in } b(1-2x)^{18}$$

$$= {}^{18}C_3 \cdot 2^3 + a {}^{18}C_2 \cdot 2^2 - b {}^{18}C_1 \cdot 2$$

Given, coefficient of $x^3 = 0$

$$\Rightarrow {}^{18}C_3 \cdot 2^3 + a {}^{18}C_2 \cdot 2^2 - b {}^{18}C_1 \cdot 2 = 0$$

$$\Rightarrow -\frac{18 \times 17 \times 16}{3 \times 2} \cdot 8 + a \cdot \frac{18 \times 17}{2} \cdot 2^2 - b \cdot 18 \cdot 2 = 0$$

$$\Rightarrow 17a - b = \frac{34 \times 16}{3}$$
 ... (i)

Similarly, coefficient of $x^4 = 0$

$$\Rightarrow {}^{18}C_4 \cdot 2^4 - a {}^{18}C_3 \cdot 2^3 + b {}^{18}C_2 \cdot 2^2 = 0$$

$$\therefore 32a - 3b = 240$$
 ... (ii)

On solving Eqs. (i) and (ii), we get

$$a = 16, b = \frac{272}{3}$$

30. Let the coefficients of 2nd, 3rd and 4th terms in the expansion of $(1+x)^n$ is ${}^nC_1, {}^nC_2, {}^nC_3$.

According to given condition,

$$\begin{aligned} 2({}^nC_2) &= {}^nC_1 + {}^nC_3 \\ \Rightarrow 2 \frac{n(n-1)}{1 \cdot 2} &= n + \frac{n(n-1)(n-2)}{1 \cdot 2 \cdot 3} \\ \Rightarrow n-1 &= 1 + \frac{(n-1)(n-2)}{6} \\ \Rightarrow n-1 &= 1 + \frac{n^2-3n+2}{6} \\ \Rightarrow 6n-6 &= 6+n^2-3n+2 \\ \Rightarrow n^2-9n+14 &= 0 \Rightarrow (n-2)(n-7) = 0 \\ \Rightarrow n &= 2 \Rightarrow n = 7 \end{aligned}$$

But nC_3 is true for $n \geq 3$, therefore $n = 7$ is the answer.

31. Given,

$$\begin{aligned} (1+ax)^n &= 1 + 8x + 24x^2 + \dots \\ \Rightarrow 1 + anx + \frac{n(n-1)}{2!} a^2 x^2 + \dots &= 1 + 8x + 24x^2 + \dots \\ \therefore an = 8 \text{ and } a^2 \frac{n(n-1)}{2} = 24 &\Rightarrow 8(8-a) = 48 \\ \Rightarrow 8-a = 6 &\Rightarrow a = 2 \\ \text{Hence, } a = 2 \text{ and } n = 4 \end{aligned}$$

32. Since, n is an odd integer, $(-1)^{n-1} = 1$

and $n-1, n-3, n-5, \dots$, are even integers, then

$$\begin{aligned} n^3 - (n-1)^3 + (n-2)^3 - (n-3)^3 + \dots + (-1)^{n-1} \cdot 1^3 \\ = n^3 + (n-1)^3 + (n-2)^3 + \dots + 1^3 \\ - 2[(n-1)^3 + (n-3)^3 + \dots + 2^3] \\ = \Sigma n^3 - 2 \times 2^3 \left[\left(\frac{n-1}{2}\right)^3 + \left(\frac{n-3}{2}\right)^3 + \dots + 1^3 \right] \\ [\because n-1, n-3, \dots, \text{ are even integers}] \\ = \Sigma n^3 - 16 \left[\Sigma \left(\frac{n-1}{2}\right)^3 \right] \\ = \left[\frac{n(n+1)}{2} \right]^2 - 16 \left[\frac{1}{2} \left(\frac{n-1}{2}\right) \left(\frac{n-1}{2} + 1\right) \right]^2 \\ = \frac{1}{4} n^2 (n+1)^2 - \frac{16(n-1)^2 (n+1)^2}{4 \times 4 \times 4} \\ = \frac{1}{4} (n+1)^2 [n^2 - (n-1)^2] = \frac{1}{4} (n+1)^2 (2n-1) \end{aligned}$$

33. Consider, $(101)^{50} - (99)^{50} - (100)^{50}$

$$\begin{aligned} &= (100+1)^{50} - (100-1)^{50} - (100)^{50} \\ &= \{(100)^{50} (1+0.01)^{50} - (1-0.01)^{50} - 1\} \\ &= (100)^{50} \{2 \cdot [{}^{50}C_1(0.01) + {}^{50}C_3(0.01)^3 + \dots] - 1\} \\ &= (100)^{50} \{2 [{}^{50}C_3(0.01)^3 + {}^{50}C_5(0.01)^5 + \dots]\} \\ \therefore (101)^{50} - \{(99)^{50} + (100)^{50}\} &> 0 \\ \Rightarrow (101)^{50} &> (99)^{50} + (100)^{50} \end{aligned}$$

34. Since, n is an even positive integer, we can write $n = 2m, m = 1, 2, 3, \dots$

Also, $k = \frac{3n}{2} = \frac{3(2m)}{2} = 3m \therefore S = \sum_{r=1}^{3m} (-3)^{r-1} \cdot {}^{6m}C_{2r-1}$

i.e. $S = (-3)^0 {}^{6m}C_1 + (-3)^1 {}^{6m}C_3 + \dots + (-3)^{3m-1} \cdot {}^{6m}C_{3m-1} \dots(i)$

From the binomial expansion, we write $(1+x)^{6m} = {}^{6m}C_0 + {}^{6m}C_1x + {}^{6m}C_2x^2 + \dots + {}^{6m}C_{6m-1}x^{6m-1} + {}^{6m}C_{6m}x^{6m} \dots(ii)$

$(1-x)^{6m} = {}^{6m}C_0 + {}^{6m}C_1(-x) + {}^{6m}C_2(-x)^2 + \dots + {}^{6m}C_{6m-1}(-x)^{6m-1} + {}^{6m}C_{6m}(-x)^{6m} \dots(iii)$

On subtracting Eq. (iii) from Eq. (ii), we get $(1+x)^{6m} - (1-x)^{6m} = 2 [{}^{6m}C_1x + {}^{6m}C_3x^3 + {}^{6m}C_5x^5 + \dots + {}^{6m}C_{6m-1}x^{6m-1}]$

$$\Rightarrow \frac{(1+x)^{6m} - (1-x)^{6m}}{2x} = {}^{6m}C_1 + {}^{6m}C_3x^2 + {}^{6m}C_5x^4 + \dots + {}^{6m}C_{6m-1}x^{6m-2}$$

Let $x^2 = y$

$$\Rightarrow \frac{(1+\sqrt{y})^{6m} - (1-\sqrt{y})^{6m}}{2\sqrt{y}} = {}^{6m}C_1 + {}^{6m}C_3y + {}^{6m}C_5y^2 + \dots + {}^{6m}C_{6m-1}y^{3m-1}$$

For the required sum we have to put $y = -3$ in RHS.

$$\begin{aligned} \therefore S &= \frac{(1+\sqrt{-3})^{6m} - (1-\sqrt{-3})^{6m}}{2\sqrt{-3}} \\ &= \frac{(1+i\sqrt{3})^{6m} - (1-i\sqrt{3})^{6m}}{2i\sqrt{3}} \dots(iv) \end{aligned}$$

Let $z = 1 + i\sqrt{3} = r(\cos \theta + i \sin \theta)$

$$\Rightarrow r = |z| = \sqrt{1+3} = 2$$

and $\theta = \pi/3$

Now, $z^{6m} = [r(\cos \theta + i \sin \theta)]^{6m} = r^{6m}(\cos 6m\theta + i \sin 6m\theta)$

Again, $\bar{z} = r(\cos \theta - i \sin \theta)$

and $(\bar{z})^{6m} = r^{6m}(\cos 6m\theta - i \sin 6m\theta)$

$$\Rightarrow z^{6m} - \bar{z}^{6m} = r^{6m}(2i \sin 6m\theta) \dots(v)$$

From Eq. (i),

$$\begin{aligned} S &= \frac{z^{6m} - \bar{z}^{6m}}{2i\sqrt{3}} = \frac{r^{6m}(2i \sin 6m\theta)}{2i\sqrt{3}} = \frac{2^{6m} \sin 6m\theta}{\sqrt{3}} \\ &= 0 \text{ as } m \in z, \text{ and } \theta = \pi/3 \end{aligned}$$

35. Let $y = (x-a)^m$, where m is a positive integer, $r \leq m$

Now, $\frac{dy}{dx} = m(x-a)^{m-1} \Rightarrow \frac{d^2y}{dx^2} = m(m-1)(x-a)^{m-2}$

$$\Rightarrow \frac{d^3y}{dx^3} = m(m-1)(m-2)(x-a)^{m-3}$$

.....

On differentiating r times, we get

$$\begin{aligned} \frac{d^r y}{dx^r} &= m(m-1) \dots (m-r+1)(x-a)^{m-r} \\ &= \frac{m!}{(m-r)!} (x-a)^{m-r} = r!({}^mC_r)(x-a)^{m-r} \end{aligned}$$

98 Binomial Theorem

and for $r > m$, $\frac{d^r y}{dx^r} = 0$

$$\text{Now, } \sum_{r=0}^{2n} a_r (x-2)^r = \sum_{r=0}^{2n} b_r (x-3)^r \quad [\text{given}]$$

On differentiating both sides n times w.r.t. x , we get

$$\sum_{r=n}^{2n} a_r (n!)^r C_n (x-2)^{r-n} = \sum_{r=n}^{2n} b_r (n!)^r C_n (x-3)^{r-n}$$

On putting $x=3$, we get

$$\sum_{r=n}^{2n} a_r (n!)^r C_n = (b_n) n!$$

[since, all the terms except first on RHS become zero]

$$\begin{aligned} \Rightarrow b_n &= {}^n C_n + {}^{n+1} C_n + {}^{n+2} C_n + \dots + {}^{2n} C_n \\ & \quad [\because a_r = 1, \forall r \geq n] \\ &= ({}^{n+2} C_{n+1} + {}^{n+2} C_n) + \dots + {}^{2n} C_n \\ &= {}^{n+3} C_{n+1} + \dots + {}^{2n} C_n = \dots \\ &= {}^{2n} C_{n+1} + {}^{2n} C_n = {}^{2n+1} C_{n+1} \end{aligned}$$

$$\begin{aligned} 36. \sum_{r=0}^n (-1)^r {}^n C_r \left[\frac{1}{2^r} + \frac{3^r}{2^{2r}} + \frac{7^r}{2^{3r}} + \frac{15^r}{2^{4r}} + \dots \text{ upto } m \text{ terms} \right] \\ = \sum_{r=0}^n (-1)^r {}^n C_r \left(\frac{1}{2} \right)^r + \sum_{r=0}^n (-1)^r {}^n C_r \left(\frac{3}{4} \right)^r + \\ \sum_{r=0}^n (-1)^r {}^n C_r \left(\frac{7}{8} \right)^r + \dots \text{ upto } m \text{ terms} \\ = \left(1 - \frac{1}{2} \right)^n + \left(1 - \frac{3}{4} \right)^n + \left(1 - \frac{7}{8} \right)^n + \dots \text{ upto } m \text{ terms} \\ \left[\text{using } \sum_{r=0}^n (-1)^r {}^n C_r x^r = (1-x)^n \right] \\ = \left(\frac{1}{2} \right)^n + \left(\frac{1}{4} \right)^n + \left(\frac{1}{8} \right)^n + \dots \text{ upto } m \text{ terms} \\ = \left(\frac{1}{2} \right)^n \left[\frac{1 - \left(\frac{1}{2} \right)^m}{1 - \frac{1}{2}} \right] = \frac{2^{mn} - 1}{2^{mn} (2^n - 1)} \end{aligned}$$

$$\begin{aligned} 37. {}^{n+1} C_1 + {}^{n+1} C_2 s_1 + {}^{n+1} C_3 s_2 + \dots + {}^{n+1} C_{n+1} s_n \\ = \sum_{r=1}^{n+1} {}^{n+1} C_r s_{r-1}, \end{aligned}$$

$$\text{where } s_n = 1 + q + q^2 + \dots + q^n = \frac{1 - q^{n+1}}{1 - q}$$

$$\begin{aligned} \therefore \sum_{r=1}^{n+1} {}^{n+1} C_r \left(\frac{1-q^r}{1-q} \right) &= \frac{1}{1-q} \left(\sum_{r=1}^{n+1} {}^{n+1} C_r - \sum_{r=1}^{n+1} {}^{n+1} C_r q^r \right) \\ &= \frac{1}{1-q} [(1+1)^{n+1} - (1+q)^{n+1}] \\ &= \frac{1}{1-q} [2^{n+1} - (1+q)^{n+1}] \quad \dots (i) \end{aligned}$$

$$\text{Also, } S_n = 1 + \left(\frac{q+1}{2} \right) + \left(\frac{q+1}{2} \right)^2 + \dots + \left(\frac{q+1}{2} \right)^n$$

$$= \frac{1 - \left(\frac{q+1}{2} \right)^{n+1}}{1 - \left(\frac{q+1}{2} \right)} = \frac{2^{n+1} - (q+1)^{n+1}}{2^n (1-q)} \quad \dots (ii)$$

From Eqs. (i) and (ii),

$${}^{n+1} C_1 + {}^{n+1} C_2 s_1 + {}^{n+1} C_3 s_2 + \dots + {}^{n+1} C_{n+1} s_n = 2^n S_n$$

38. The general term (i.e. $(r+1)$ th term) in the expansion of binomial $\left(x^m + \frac{1}{x^2} \right)^{22}$ is

$$T_{r+1} = {}^{22} C_r (x^m)^{22-r} x^{-2r}$$

\therefore The coefficient ${}^{22} C_r = 1540$ [given]

$$\Rightarrow r = 3 \text{ or } 19$$

$$\text{and } 22m - mr - 2r = 1$$

$$\text{at } r = 3, 22m - 3m - 6 = 1 \Rightarrow 18m = 7$$

$$\Rightarrow m = \frac{7}{18} \notin N$$

$$\text{Now, at } r = 19, 22m - 19m - 38 = 1$$

$$\Rightarrow 3m = 39 \Rightarrow m = 13 \in N$$

So, the natural value of $m = 13$

39. Coefficient of x^2 in the expansion of

$$\begin{aligned} \{ (1+x)^2 + (1+x)^3 + \dots + (1+x)^{49} + (1+mx)^{50} \} \\ \Rightarrow {}^2 C_2 + {}^3 C_2 + {}^4 C_2 + \dots + {}^{49} C_2 + {}^{50} C_2 \cdot m^2 = (3n+1) \cdot {}^{51} C_3 \\ \Rightarrow {}^{50} C_3 + {}^{50} C_2 m^2 = (3n+1) \cdot {}^{51} C_3 \\ [\because {}^r C_r + {}^{r+1} C_r + \dots + {}^n C_r = {}^{n+1} C_{r+1}] \\ \Rightarrow \frac{50 \times 49 \times 48}{3 \times 2 \times 1} + \frac{50 \times 49}{2} \times m^2 = (3n+1) \frac{51 \times 50 \times 49}{3 \times 2 \times 1} \end{aligned}$$

$$\Rightarrow m^2 = 51n + 1$$

\therefore Minimum value of m^2 for which $(51n+1)$ is integer (perfect square) for $n=5$.

$$\therefore m^2 = 51 \times 5 + 1 \Rightarrow m^2 = 256 \Rightarrow m = 16 \text{ and } n = 5$$

Hence, the value of n is 5.

40. Coefficient of x^9 in the expansion of

$$\begin{aligned} (1+x)(1+x^2)(1+x^3) \dots (1+x^{100}) = \text{Terms having } x^9 \\ = [1^{99} \cdot x^9, 1^{98} \cdot x \cdot x^8, 1^{98} \cdot x^2 \cdot x^7, 1^{98} \cdot x^3 \cdot x^6, \\ 1^{98} \cdot x^4 \cdot x^5, 1^{97} \cdot x \cdot x^2 \cdot x^6, 1^{97} \cdot x \cdot x^3 \cdot x^5, 1^{97} \cdot x^2 \cdot x^3 \cdot x^4] \\ \therefore \text{Coefficient of } x^9 = 8 \end{aligned}$$

41. Let the three consecutive terms in $(1+x)^{n+5}$ be t_r, t_{r+1}, t_{r+2} having coefficients

$${}^{n+5} C_{r-1}, {}^{n+5} C_r, {}^{n+5} C_{r+1}.$$

$$\text{Given, } {}^{n+5} C_{r-1} : {}^{n+5} C_r : {}^{n+5} C_{r+1} = 5 : 10 : 14$$

$$\therefore \frac{{}^{n+5} C_r}{{}^{n+5} C_{r-1}} = \frac{10}{5} \text{ and } \frac{{}^{n+5} C_{r+1}}{{}^{n+5} C_r} = \frac{14}{10}$$

$$\Rightarrow \frac{n+5-(r-1)}{r} = 2 \text{ and } \frac{n-r+5}{r+1} = \frac{7}{5}$$

$$\Rightarrow n - r + 6 = 2r$$

$$\text{and } 5n - 5r + 25 = 7r + 7$$

$$\Rightarrow n + 6 = 3r \text{ and } 5n + 18 = 12r$$

$$\therefore \frac{n+6}{3} = \frac{5n+18}{12}$$

$$\Rightarrow 4n + 24 = 5n + 18 \Rightarrow n = 6$$

Topic 2 Properties of Binomial Coefficient

1. We have,

$$\begin{aligned} (x + 10)^{50} + (x - 10)^{50} &= a_0 + a_1x + a_2x^2 + \dots + a_{50}x^{50} \\ \therefore a_0 + a_1x + a_2x^2 + \dots + a_{50}x^{50} \\ &= [({}^{50}C_0x^{50} + {}^{50}C_1x^{49} \cdot 10 + {}^{50}C_2x^{48} \cdot 10^2 + \dots + {}^{50}C_{50} 10^{50}) \\ &\quad + ({}^{50}C_0x^{50} - {}^{50}C_1x^{49} \cdot 10 + {}^{50}C_2x^{48} \cdot 10^2 - \dots + {}^{50}C_{50} 10^{50})] \\ &= 2 [{}^{50}C_0x^{50} + {}^{50}C_2x^{48} \cdot 10^2 + {}^{50}C_4x^{46} \cdot 10^4 \\ &\quad + \dots + {}^{50}C_{50} \cdot 10^{50}] \end{aligned}$$

By comparing coefficients, we get

$$\begin{aligned} a_2 &= 2 \cdot {}^{50}C_48(10)^{48}; \quad a_0 = 2 \cdot {}^{50}C_{50}(10)^{50} = 2(10)^{50} \\ \therefore \frac{a_2}{a_0} &= \frac{2({}^{50}C_2)(10)^{48}}{2(10)^{50}} = 2 \frac{50 \cdot 49}{1 \cdot 2} \frac{(10)^{48}}{2 \cdot (10)^{50}} \\ &= \frac{50 \times 49}{2 \cdot (10 \times 10)} = \frac{5 \times 49}{20} = \frac{245}{20} = 12.25 \quad [\because {}^{50}C_{48} = {}^{50}C_2] \end{aligned}$$

2. We know that,

$$\begin{aligned} (1 + x)^{20} &= {}^{20}C_0 + {}^{20}C_1x + {}^{20}C_2x^2 + \dots + \\ &\quad {}^{20}C_{r-1}x^{r-1} + {}^{20}C_r x^r + \dots + {}^{20}C_{20}x^{20} \\ \therefore (1 + x)^{20} \cdot (1 + x)^{20} &= ({}^{20}C_0 + {}^{20}C_1x + \\ &\quad {}^{20}C_2x^2 + \dots + {}^{20}C_{r-1}x^{r-1} + {}^{20}C_r x^r + \dots + {}^{20}C_{20}x^{20}) \\ &\quad \times ({}^{20}C_0 + {}^{20}C_1x + \dots + {}^{20}C_{r-1}x^{r-1} + {}^{20}C_r x^r \\ &\quad + \dots + {}^{20}C_{20}x^{20}) \\ \Rightarrow (1 + x)^{40} &= ({}^{20}C_0 \cdot {}^{20}C_r + {}^{20}C_1 \cdot {}^{20}C_{r-1} \dots \\ &\quad \dots + {}^{20}C_r \cdot {}^{20}C_0) x^r + \dots \end{aligned}$$

On comparing the coefficient of x^r of both sides, we get

$${}^{20}C_0 {}^{20}C_r + {}^{20}C_1 {}^{20}C_{r-1} + \dots + {}^{20}C_r {}^{20}C_0 = {}^{40}C_r$$

The maximum value of ${}^{40}C_r$ is possible only when $r = 20$

$$[\because {}^nC_{n/2} \text{ is maximum when } n \text{ is even}]$$

Thus, required value of r is 20.

3. Consider,

$$\begin{aligned} 2^{403} &= 2^{400+3} = 8 \cdot 2^{400} = 8 \cdot (2^4)^{100} = 8(16)^{100} = 8(1 + 15)^{100} \\ &= 8(1 + {}^{100}C_1(15) + {}^{100}C_2(15)^2 + \dots + {}^{100}C_{100}(15)^{100}) \end{aligned}$$

[By binomial theorem,

$$\begin{aligned} (1 + x)^n &= {}^nC_0 + {}^nC_1x + {}^nC_2x^2 + \dots + {}^nC_nx^n, \quad n \in N \\ &= 8 + 8({}^{100}C_1(15) + {}^{100}C_2(15)^2 + \dots + {}^{100}C_{100}(15)^{100}) \\ &= 8 + 8 \times 15\lambda \end{aligned}$$

$$\text{where } \lambda = {}^{100}C_1 + \dots + {}^{100}C_{100}(15)^{99} \in N$$

$$\therefore \frac{2^{403}}{15} = \frac{8 + 8 \times 15\lambda}{15} = 8\lambda + \frac{8}{15} \Rightarrow \left\{ \frac{2^{403}}{15} \right\} = \frac{8}{15}$$

(where $\{ \}$ is the fractional part function)

$$\therefore k = 8$$

Alternate Method

$$2^{403} = 8 \cdot 2^{400} = 8(16)^{100}$$

Note that, when 16 is divided by 15, gives remainder 1.

\therefore When $(16)^{100}$ is divided by 15, gives remainder $1^{100} = 1$ and when $8(16)^{100}$ is divided by 15, gives remainder 8.

$$\therefore \left\{ \frac{2^{403}}{15} \right\} = \frac{8}{15}$$

(where $\{ \}$ is the fractional part function)

$$\Rightarrow k = 8$$

4. $A_r =$ Coefficient of x^r in $(1 + x)^{10} = {}^{10}C_r$

$B_r =$ Coefficient of x^r in $(1 + x)^{20} = {}^{20}C_r$

$C_r =$ Coefficient of x^r in $(1 + x)^{30} = {}^{30}C_r$

$$\therefore \sum_{r=1}^{10} A_r (B_{10} B_r - C_{10} A_r) = \sum_{r=1}^{10} A_r B_{10} B_r - \sum_{r=1}^{10} A_r C_{10} A_r$$

$$= \sum_{r=1}^{10} {}^{10}C_r \cdot {}^{20}C_{10} \cdot {}^{20}C_r - \sum_{r=1}^{10} {}^{10}C_r \cdot {}^{30}C_{10} \cdot {}^{10}C_r$$

$$= \sum_{r=1}^{10} {}^{10}C_{10-r} \cdot {}^{20}C_{10} \cdot {}^{20}C_r - \sum_{r=1}^{10} {}^{10}C_{10-r} \cdot {}^{30}C_{10} \cdot {}^{10}C_r$$

$$= {}^{20}C_{10} \sum_{r=1}^{10} {}^{10}C_{10-r} \cdot {}^{20}C_r - {}^{30}C_{10} \sum_{r=1}^{10} {}^{10}C_{10-r} \cdot {}^{10}C_r$$

$$= {}^{20}C_{10} ({}^{30}C_{10} - 1) - {}^{30}C_{10} ({}^{20}C_{10} - 1)$$

$$= {}^{30}C_{10} - {}^{20}C_{10} = C_{10} - B_{10}$$

5. Let $A = \binom{30}{0} \binom{30}{10} - \binom{30}{1} \binom{30}{11} + \binom{30}{2} \binom{30}{12} - \dots + \binom{30}{20} \binom{30}{30}$

$$\therefore A = {}^{30}C_0 \cdot {}^{30}C_{10} - {}^{30}C_1 \cdot {}^{30}C_{11} + {}^{30}C_2 \cdot {}^{30}C_{12} - \dots + {}^{30}C_{20} \cdot {}^{30}C_{30}$$

$$= \text{Coefficient of } x^{20} \text{ in } (1 + x)^{30} (1 - x)^{30}$$

$$= \text{Coefficient of } x^{20} \text{ in } (1 - x^2)^{30}$$

$$= \text{Coefficient of } x^{20} \text{ in } \sum_{r=0}^{30} (-1)^r {}^{30}C_r (x^2)^r$$

$$= (-1)^{10} {}^{30}C_{10} \quad [\text{for coefficient of } x^{20}, \text{ put } r = 10]$$

$$= {}^{30}C_{10}$$

6. Given, ${}^{n-1}C_r = (k^2 - 3) {}^nC_{r+1}$

$$\Rightarrow {}^{n-1}C_r = (k^2 - 3) \frac{n}{r+1} {}^{n-1}C_r \Rightarrow k^2 - 3 = \frac{r+1}{n}$$

$$[\text{since, } n \geq r \Rightarrow \frac{r+1}{n} \leq 1 \text{ and } n, r > 0]$$

$$\Rightarrow 0 < k^2 - 3 \leq 1 \Rightarrow 3 < k^2 \leq 4$$

$$\Rightarrow k \in [-2, -\sqrt{3}) \cup (\sqrt{3}, 2]$$

7. $\sum_{i=0}^m \binom{10}{i} \binom{20}{m-i}$ is the coefficient of x^m in the expansion of

$$(1 + x)^{10} (x + 1)^{20},$$

$$\Rightarrow \sum_{i=0}^m \binom{10}{i} \binom{20}{m-i}$$
 is the coefficient of x^m in the

expansion of $(1 + x)^{30}$

100 Binomial Theorem

i.e.
$$\sum_{i=0}^m \binom{10}{i} \binom{20}{m-i} = {}^{30}C_m = \binom{30}{m} \quad \dots(i)$$

and we know that, $\binom{n}{r}$ is maximum, when

$$\binom{n}{r}_{\max} = \begin{cases} r = \frac{n}{2}, & \text{if } n \in \text{even.} \\ r = \frac{n \pm 1}{2}, & \text{if } n \in \text{odd.} \end{cases}$$

Hence, $\binom{30}{m}$ is maximum when $m = 15$.

8.
$$\binom{n}{r} + 2\binom{n}{r-1} + \binom{n}{r-2} = \left[\binom{n}{r} + \binom{n}{r-1} \right] + \left[\binom{n}{r-1} + \binom{n}{r-2} \right] = \binom{n+1}{r} + \binom{n+1}{r-1} = \binom{n+2}{r}$$

$$[\because {}^nC_r + {}^nC_{r-1} = {}^{n+1}C_r]$$

9. Let
$$b = \sum_{r=0}^n \frac{r}{{}^nC_r} = \sum_{r=0}^n \frac{n-(n-r)}{{}^nC_r}$$

$$= n \sum_{r=0}^n \frac{1}{{}^nC_r} - \sum_{r=0}^n \frac{n-r}{{}^nC_r}$$

$$= na_n - \sum_{r=0}^n \frac{n-r}{{}^nC_{n-r}} \quad [\because {}^nC_r = {}^nC_{n-r}]$$

$$= na_n - b \Rightarrow 2b = na_n \Rightarrow b = \frac{n}{2} a_n$$

10. We have,

$$C_0^2 - 2C_1^2 + 3C_2^2 - 4C_3^2 + \dots + (-1)^n (n+1) C_n^2$$

$$= [C_0^2 - C_1^2 + C_2^2 - C_3^2 + \dots + (-1)^n C_n^2]$$

$$- [C_1^2 - 2C_2^2 + 3C_3^2 - \dots + (-1)^n n C_n^2]$$

$$= (-1)^{n/2} \frac{n!}{\left(\frac{n}{2}\right)! \left(\frac{n}{2}\right)!} - (-1)^{\frac{n}{2}-1} \frac{n!}{2 \left(\frac{n}{2}\right)! \left(\frac{n}{2}\right)!}$$

$$= (-1)^{n/2} \frac{n!}{\left(\frac{n}{2}\right)! \left(\frac{n}{2}\right)!} \left(1 + \frac{n}{2}\right)$$

$$\therefore \frac{2 \left(\frac{n}{2}\right)! \left(\frac{n}{2}\right)!}{n!} [C_0^2 - 2C_1^2 + 3C_2^2 - \dots + (-1)^n (n+1) C_n^2]$$

$$= \frac{2 \left(\frac{n}{2}\right)! \left(\frac{n}{2}\right)!}{n!} (-1)^{n/2} \frac{n!}{\left(\frac{n}{2}\right)! \left(\frac{n}{2}\right)!} \frac{(n+2)}{2} = (-1)^{n/2} (n+2)$$

11. Since,

$$f(m, n, p) = \sum_{i=0}^p \binom{m}{i} \binom{n+i}{p} \binom{p+n}{p-i}$$

$$= \sum_{i=0}^p \frac{m!}{i!(m-i)!} \times \frac{(n+i)!}{p!(n+i-p)!} \times \frac{(p+n)!}{(p-i)!(n+i)!}$$

$$= \frac{(n+p)!}{p!} \sum_{i=0}^p m C_i \frac{1}{(p-i)!(n+i-p)!}$$

$$= \frac{(n+p)!}{n!p!} \sum_{i=0}^p m C_i \times {}^nC_{p-i} = {}^{n+p}C_p \cdot m \cdot {}^nC_p$$

Since,
$$g(m, n) = \sum_{p=0}^{m+n} \frac{f(m, n, p)}{\binom{n+p}{p}}$$

$$= \sum_{p=0}^{m+n} \frac{{}^{n+p}C_p \times m \cdot {}^nC_p}{{}^{n+p}C_p} = \sum_{p=0}^{m+n} m \cdot {}^nC_p = 2^{m+n}$$

$\therefore g(m, n) = g(n, m) = 2^{m+n}$, and
 $g(m, n+1) = 2^{m+n+1} = g(m+1, n)$, and
 $g(2m; 2n) = 2^{2m+2n} = (2^{m+n})^2 = (g(m, n))^2$.

12. It is given that

$$\left| \begin{array}{cc} \sum_{k=0}^n k & \sum_{k=0}^n {}^nC_k k^2 \\ \sum_{k=0}^n {}^nC_k \cdot k & \sum_{k=0}^n {}^nC_k 3^k \end{array} \right| = 0$$

$$\Rightarrow \left| \begin{array}{cc} \frac{n(n+1)}{2} & n(n+1)2^{n-2} \\ n \cdot 2^{n-1} & 4^n \end{array} \right| = 0$$

$$\left[\begin{array}{l} \therefore \sum_{k=0}^n k = \frac{n(n+1)}{2}, \quad \sum_{k=0}^n {}^nC_k k = n \cdot 2^{n-1}, \\ \sum_{k=0}^n {}^nC_k k^2 = n(n+1)2^{n-2} \quad \text{and} \quad \sum_{k=0}^n {}^nC_k 3^k = 4^n \end{array} \right]$$

$$\Rightarrow \frac{n(n+1)}{2} 4^n - n^2(n+1) 2^{2n-3} = 0$$

$$\Rightarrow \frac{4^n}{2} - n \frac{4^{n-1}}{2} = 0 \Rightarrow n = 4$$

$$\therefore \sum_{k=0}^n \frac{{}^nC_k}{k+1} = \sum_{k=0}^4 \frac{{}^4C_k}{k+1} = \frac{1}{5} \sum_{k=0}^4 {}^5C_{k+1} = \frac{1}{5} (2^5 - 1)$$

$$= \frac{1}{5} (32 - 1) = \frac{31}{5} = 6.20$$

13. We have,

$$X = ({}^{10}C_1)^2 + 2({}^{10}C_2)^2 + 3({}^{10}C_3)^2 + \dots + 10({}^{10}C_{10})^2$$

$$\Rightarrow X = \sum_{r=1}^{10} r({}^{10}C_r)^2 \Rightarrow X = \sum_{r=1}^{10} r \cdot {}^{10}C_r \cdot {}^{10}C_r$$

$$\Rightarrow X = \sum_{r=1}^{10} r \times \frac{10}{r} {}^9C_{r-1} \cdot {}^{10}C_r \quad \left[\because {}^nC_r = \frac{n}{r} {}^{n-1}C_{r-1} \right]$$

$$\Rightarrow X = 10 \sum_{r=1}^{10} {}^9C_{r-1} \cdot {}^{10}C_r$$

$$\Rightarrow X = 10 \sum_{r=1}^{10} {}^9C_{r-1} \cdot {}^{10}C_{10-r} \quad [\because {}^nC_r = {}^nC_{n-r}]$$

$$\Rightarrow X = 10 \times {}^{19}C_9 \quad [\because {}^{n-1}C_{r-1} \cdot {}^nC_{n-r} = {}^{2n-1}C_{n-1}]$$

Now,
$$\frac{1}{1430} X = \frac{10 \times {}^{19}C_9}{1430} = \frac{{}^{19}C_9}{143} = \frac{{}^{19}C_9}{11 \times 13}$$

$$= \frac{19 \times 17 \times 16}{8} = 19 \times 34 = 646$$

14. Sum of coefficients is obtained by putting $x = 1$

i.e. $(1 + 1 - 3)^{2163} = -1$

Thus, sum of the coefficients of the polynomial $(1 + x - 3x^2)^{2163}$ is -1 .

15. To show that

$$2^{k \cdot n} C_0^n C_k^n - 2^{(k-1) \cdot n} C_1^{n-1} C_{k-1}^n + 2^{(k-2) \cdot n} C_2^{n-2} C_{k-2}^n - \dots + (-1)^k C_k^{n-k} C_0^n = C_k^n$$

Taking LHS

$$\begin{aligned} & 2^{k \cdot n} C_0^n C_k^n - 2^{(k-1) \cdot n} C_1^{n-1} C_{k-1}^n + \dots + (-1)^k C_k^{n-k} C_0^n \\ &= \sum_{r=0}^k (-1)^r \cdot 2^{k-r \cdot n} C_r^{n-r} C_{k-r}^n \\ &= \sum_{r=0}^k (-1)^r 2^{k-r \cdot n} \frac{n!}{r!(n-r)!} \cdot \frac{(n-r)!}{(k-r)!(n-k)!} \\ &= \sum_{r=0}^k (-1)^r \cdot 2^{k-r \cdot n} \frac{n!}{(n-k)! \cdot k!} \cdot \frac{k!}{r!(k-r)!} \\ &= \sum_{r=0}^k (-1)^r \cdot 2^{k-r \cdot n} C_k^{n-k} C_r^k \\ &= 2^{k \cdot n} C_k^n \left\{ \sum_{r=0}^k (-1)^r \cdot \frac{1}{2^r} C_r^k \right\} \\ &= 2^{k \cdot n} C_k^n \left(1 - \frac{1}{2} \right)^k \\ &= C_k^n = \text{RHS} \end{aligned}$$

16. Let $S = \binom{n}{m} + \binom{n-1}{m} + \binom{n-2}{m} + \dots + \binom{m}{m} = \binom{n+1}{m+1}$... (i)

It is obvious that, $n \geq m$. [given]

NOTE This question is based upon additive loop.

$$\begin{aligned} \text{Now, } S &= \binom{m}{m} + \binom{m+1}{m} + \binom{m+2}{m} + \dots + \binom{n}{m} \\ &= \left\{ \binom{m+1}{m+1} + \binom{m+1}{m} \right\} + \binom{m+2}{m} + \dots + \binom{n}{m} \\ & \quad \left[\because \binom{m}{m} = 1 = \binom{m+1}{m+1} \right] \\ &= \binom{m+2}{m+1} + \binom{m+2}{m} + \dots + \binom{n}{m} \\ & \quad [\because {}^n C_r + {}^n C_{r+1} = {}^{n+1} C_{r+1}] \\ &= \binom{m+3}{m+1} + \dots + \binom{n}{m} \\ &= \dots \\ &= \binom{n}{m+1} + \binom{n}{m} = \binom{n+1}{m+1}, \text{ which is true.} \quad \dots \text{(ii)} \end{aligned}$$

Again, we have to prove that

$$\binom{n}{m} + 2 \binom{n-1}{m} + 3 \binom{n-2}{m} + \dots + (n-m+1) \binom{m}{m} = \binom{n+2}{m+2}$$

Let $S_1 = \binom{n}{m} + 2 \binom{n-1}{m} + 3 \binom{n-2}{m} + \dots + (n-m+1) \binom{m}{m}$

$$\begin{aligned} &= \left. \begin{aligned} & \binom{n}{m} + \binom{n-1}{m} + \binom{n-2}{m} + \dots + \binom{m}{m} \\ & + \binom{n-1}{m} + \binom{n-2}{m} + \dots + \binom{m}{m} \\ & + \binom{n-2}{m} + \dots + \binom{m}{m} \\ & \dots \\ & + \binom{m}{m} \end{aligned} \right\} n - m + 1 \text{ rows} \end{aligned}$$

Now, sum of the first row is $\binom{n+1}{m+1}$.

Sum of the second row is $\binom{n}{m+1}$.

Sum of the third row is $\binom{n-1}{m+1}$,

.....

Sum of the last row is $\binom{m}{m} = \binom{m+1}{m+1}$.

Thus, $S = \binom{n+1}{m+1} + \binom{n}{m+1} + \binom{n-1}{m+1} + \dots + \binom{m+1}{m+1} = \binom{n+1+1}{m+2} = \binom{n+2}{m+2}$

[from Eq. (i) replacing n by $n + 1$ and m by $m + 1$]

$$\begin{aligned} 17. \sum_{r=0}^n (-1)^r \frac{{}^n C_r}{r+3} &= \sum_{r=0}^n (-1)^r \frac{n! \cdot 3!}{(n-r)! (r+3)!} = 3! \sum_{r=0}^n (-1)^r \frac{n!}{(n-r)! (r+3)!} \\ &= \frac{3!}{(n+1)(n+2)(n+3)} \sum_{r=0}^n \frac{(-1)^r \cdot (n+3)!}{(n-r)! (r+3)!} \\ &= \frac{3!}{(n+1)(n+2)(n+3)} \cdot \sum_{r=0}^n (-1)^r \cdot {}^{n+3} C_{r+3} \\ &= \frac{3!(-1)^3}{(n+1)(n+2)(n+3)} \sum_{s=3}^{n+3} (-1)^s \cdot {}^{n+3} C_s \\ &= \frac{-3!}{(n+1)(n+2)(n+3)} \left(\sum_{s=0}^{n+3} (-1)^s \cdot {}^{n+3} C_s \right) \\ & \quad - {}^{n+3} C_0 + {}^{n+3} C_1 - {}^{n+3} C_2 \\ &= \frac{-3!}{(n+1)(n+2)(n+3)} \left\{ 0 - 1 + (n+3) - \frac{(n+3)(n+2)}{2!} \right\} \\ &= \frac{-3!}{(n+1)(n+2)(n+3)} \cdot \frac{(n+2)(2-n-3)}{2} = \frac{3!}{2(n+3)} \end{aligned}$$

18. $(1 + x + x^2)^n = a_0 + a_1 x + \dots + a_{2n} x^{2n}$... (i)

Replacing x by $-1/x$, we get

$$\left(1 - \frac{1}{x} + \frac{1}{x^2} \right)^n = a_0 - \frac{a_1}{x} + \frac{a_2}{x^2} - \frac{a_3}{x^3} + \dots + \frac{a_{2n}}{x^{2n}} \quad \dots \text{(ii)}$$

102 Binomial Theorem

Now, $a_0^2 - a_1^2 + a_2^2 - a_3^2 + \dots + a_{2n}^2 =$ coefficient of the term independent of x in

$$[a_0 + a_1x + a_2x^2 + \dots + a_{2n}x^{2n}] \times \left[a_0 - \frac{a_1}{x} + \frac{a_2}{x^2} - \dots + \frac{a_{2n}}{x^{2n}} \right]$$

= Coefficient of the term independent of x in

$$(1 + x + x^2)^n \left(1 - \frac{1}{x} + \frac{1}{x^2} \right)^n$$

$$\begin{aligned} \text{Now, RHS} &= (1 + x + x^2)^n \left(1 - \frac{1}{x} + \frac{1}{x^2} \right)^n \\ &= \frac{(1 + x + x^2)^n (x^2 - x + 1)^n}{x^{2n}} = \frac{[(x^2 + 1)^2 - x^2]^n}{x^{2n}} \\ &= \frac{(1 + 2x^2 + x^4 - x^2)^n}{x^{2n}} = \frac{(1 + x^2 + x^4)^n}{x^{2n}} \end{aligned}$$

$$\begin{aligned} \text{Thus, } a_0^2 - a_1^2 + a_2^2 - a_3^2 + \dots + a_{2n}^2 &= \text{Coefficient of the term independent of } x \text{ in} \\ &= \frac{1}{x^{2n}} (1 + x^2 + x^4)^n \end{aligned}$$

$$\begin{aligned} &= \text{Coefficient of } x^{2n} \text{ in } (1 + x^2 + x^4)^n \\ &= \text{Coefficient of } t^n \text{ in } (1 + t + t^2)^n = a_n \end{aligned}$$

$$\begin{aligned} \mathbf{19.} \quad C_0 - 2^2 \cdot C_1 + 3^2 \cdot C_2 - \dots + (-1)^n (n+1)^2 \cdot C_n &= \sum_{r=0}^n (-1)^r (r+1)^2 {}^n C_r = \sum_{r=0}^n (-1)^r (r^2 + 2r + 1) {}^n C_r \\ &= \sum_{r=0}^n (-1)^r r^2 \cdot {}^n C_r + 2 \sum_{r=0}^n (-1)^r r \cdot {}^n C_r + \sum_{r=0}^n (-1)^r \cdot {}^n C_r \\ &= \sum_{r=0}^n (-1)^r \cdot r(r-1) \cdot {}^n C_r + 3 \sum_{r=0}^n (-1)^r \cdot r \cdot {}^n C_r \\ &\quad + \sum_{r=0}^n (-1)^r {}^n C_r \\ &= \sum_{r=2}^n (-1)^r n(n-1) {}^{n-2} C_{r-2} + 3 \sum_{r=1}^n (-1)^r n \cdot {}^{n-1} C_{r-1} \\ &\quad + \sum_{r=0}^n (-1)^r {}^n C_r \\ &= n(n-1) \{ {}^{n-2} C_0 - {}^{n-2} C_1 + {}^{n-2} C_2 - \dots + (-1)^n {}^{n-2} C_{n-2} \} \\ &\quad + 3n \{ -{}^{n-1} C_0 + {}^{n-1} C_1 - {}^{n-1} C_2 + \dots + (-1)^n {}^{n-1} C_{n-1} \} \\ &\quad + \{ {}^n C_0 - {}^n C_1 + {}^n C_2 - \dots + (-1)^n {}^n C_n \} \\ &= n(n-1) \cdot 0 + 3n \cdot 0 + 0, \forall n > 2 = 0, \forall n > 2 \end{aligned}$$

20. We know that,

$$\begin{aligned} 2 \sum_{0 \leq i < j \leq n} C_i C_j &= \sum_{i=0}^n \sum_{j=0}^n C_i C_j - \sum_{i=0}^n \sum_{j=0}^n C_i C_j \\ &= \sum_{i=0}^n C_i \sum_{j=0}^n C_j - \sum_{i=0}^n C_i^2 \end{aligned}$$

$$= 2^n 2^n - ({}^{2n} C_n) = 2^{2n} - {}^{2n} C_n$$

$$\therefore \sum_{0 \leq i < j \leq n} C_i C_j = \frac{2^{2n} - {}^{2n} C_n}{2} = 2^{2n-1} - \frac{(2n)!}{2(n!)^2}$$

21. We know that, $(1+x)^{2n} = C_0 + C_1x + C_2x^2 + \dots + C_{2n}x^{2n}$

On differentiating both sides w.r.t. x , we get

$$2n(1+x)^{2n-1} = C_1 + 2 \cdot C_2x + 3 \cdot C_3x^2 + \dots + 2n C_{2n} x^{2n-1} \dots \text{(i)}$$

$$\begin{aligned} \text{and } \left(1 - \frac{1}{x} \right)^{2n} &= C_0 - C_1 \cdot \frac{1}{x} + C_2 \cdot \frac{1}{x^2} - C_3 \cdot \frac{1}{x^3} \\ &\quad + \dots + C_{2n} \cdot \frac{1}{x^{2n}} \dots \text{(ii)} \end{aligned}$$

On multiplying Eqs. (i) and (ii), we get

$$\begin{aligned} 2n(1+x)^{2n-1} \left(1 - \frac{1}{x} \right)^{2n} &= [C_1 + 2 \cdot C_2x + 3 \cdot C_3x^2 + \dots + 2n \cdot C_{2n}x^{2n-1}] \\ &\quad \times \left[C_0 - C_1 \left(\frac{1}{x} \right) + C_2 \left(\frac{1}{x^2} \right) - \dots + C_{2n} \left(\frac{1}{x^{2n}} \right) \right] \end{aligned}$$

Coefficient of $\left(\frac{1}{x} \right)$ on the LHS

$$\begin{aligned} &= \text{Coefficient of } \frac{1}{x} \text{ in } 2n \left(\frac{1}{x^{2n}} \right) (1+x)^{2n-1} (x-1)^{2n} \\ &= \text{Coefficient of } x^{2n-1} \text{ in } 2n(1-x^2)^{2n-1} (1-x) \\ &= 2n(-1)^{n-1} \cdot (2n-1) C_{n-1} (-1) \\ &= (-1)^n (2n) \frac{(2n-1)!}{(n-1)! n!} = (-1)^n n \frac{(2n)!}{(n!)^2} \cdot n \\ &= -(-1)^n n \cdot C_n \dots \text{(iii)} \end{aligned}$$

Again, the coefficient of $\left(\frac{1}{x} \right)$ on the RHS

$$= -(C_1^2 - 2 \cdot C_2^2 + 3 \cdot C_3^2 - \dots - 2n \cdot C_{2n}^2) \dots \text{(iv)}$$

From Eqs. (iii) and (iv),

$$C_1^2 - 2 \cdot C_2^2 + 3 \cdot C_3^2 - \dots - 2n \cdot C_{2n}^2 = (-1)^n n \cdot C_n$$

$$\begin{aligned} \mathbf{22.} \quad (1+x)^{2n} \left(1 - \frac{1}{x} \right)^{2n} &= [{}^{2n} C_0 + ({}^{2n} C_1)x + ({}^{2n} C_2)x^2 + \dots + ({}^{2n} C_{2n})x^{2n}] \\ &\quad \times \left[{}^{2n} C_0 - ({}^{2n} C_1) \frac{1}{x} + ({}^{2n} C_2) \frac{1}{x^2} + \dots + ({}^{2n} C_{2n}) \frac{1}{x^{2n}} \right] \end{aligned}$$

Independent terms of x on RHS

$$= ({}^{2n} C_0)^2 - ({}^{2n} C_1)^2 + ({}^{2n} C_2)^2 - \dots + ({}^{2n} C_{2n})^2$$

$$\text{LHS} = (1+x)^{2n} \left(\frac{x-1}{x} \right)^{2n} = \frac{1}{x^{2n}} (1-x^2)^{2n}$$

Independent term of x on the LHS = $(-1)^n \cdot {}^{2n} C_n$.

6

Probability

Topic 1 Classical Probability

Objective Questions I (Only one correct option)

1. A person throws two fair dice. He wins ₹ 15 for throwing a doublet (same numbers on the two dice), wins ₹ 12 when the throw results in the sum of 9, and loses ₹ 6 for any other outcome on the throw. Then, the expected gain/loss (in ₹) of the person is
(2019 Main, 12 April II)

- (a) $\frac{1}{2}$ gain (b) $\frac{1}{4}$ loss (c) $\frac{1}{2}$ loss (d) 2 gain

2. In a random experiment, a fair die is rolled until two fours are obtained in succession. The probability that the experiment will end in the fifth throw of the die is equal to
(2019 Main, 12 Jan I)

- (a) $\frac{175}{6^5}$ (b) $\frac{225}{6^5}$
(c) $\frac{200}{6^5}$ (d) $\frac{150}{6^5}$

3. If three of the six vertices of a regular hexagon are chosen at random, then the probability that the triangle formed with these chosen vertices is equilateral is
(2019 Main, 12 April I)

- (a) $\frac{1}{10}$ (b) $\frac{1}{5}$ (c) $\frac{3}{10}$ (d) $\frac{3}{20}$

4. Let $S = \{1, 2, \dots, 20\}$. A subset B of S is said to be "nice", if the sum of the elements of B is 203. Then, the probability that a randomly chosen subset of S is "nice", is
(2019 Main, 11 Jan II)

- (a) $\frac{6}{2^{20}}$ (b) $\frac{4}{2^{20}}$ (c) $\frac{7}{2^{20}}$ (d) $\frac{5}{2^{20}}$

5. If two different numbers are taken from the set $\{0, 1, 2, 3, \dots, 10\}$, then the probability that their sum as well as absolute difference are both multiple of 4, is
(2017 Main)

- (a) $\frac{6}{55}$ (b) $\frac{12}{55}$ (c) $\frac{14}{45}$ (d) $\frac{7}{55}$

6. Three randomly chosen non-negative integers x , y and z are found to satisfy the equation $x + y + z = 10$. Then the probability that z is even, is
(2017 Adv.)

- (a) $\frac{1}{2}$ (b) $\frac{36}{55}$ (c) $\frac{6}{11}$ (d) $\frac{5}{11}$

7. If 12 identical balls are to be placed in 3 different boxes, then the probability that one of the boxes contains exactly 3 balls, is
(2015 Main)

- (a) $\frac{55}{3} \left(\frac{2}{3}\right)^{11}$ (b) $55 \left(\frac{2}{3}\right)^{10}$ (c) $220 \left(\frac{1}{3}\right)^{12}$ (d) $22 \left(\frac{1}{3}\right)^{11}$

8. Three boys and two girls stand in a queue. The probability that the number of boys ahead of every girl is at least one more than the number of girls ahead of her, is
(2014 Adv.)

- (a) 1/2 (b) 1/3 (c) 2/3 (d) 3/4

9. Four fair dice D_1, D_2, D_3 and D_4 each having six faces numbered 1, 2, 3, 4, 5 and 6 are rolled simultaneously. The probability that D_4 shows a number appearing on one of D_1, D_2 and D_3 , is
(2012)

- (a) $\frac{91}{216}$ (b) $\frac{108}{216}$ (c) $\frac{125}{216}$ (d) $\frac{127}{216}$

10. Let ω be a complex cube root of unity with $\omega \neq 1$. A fair die is thrown three times. If r_1, r_2 and r_3 are the numbers obtained on the die, then the probability that $\omega^{r_1} + \omega^{r_2} + \omega^{r_3} = 0$, is
(2010)

- (a) 1/18 (b) 1/9 (c) 2/9 (d) 1/36

11. If three distinct numbers are chosen randomly from the first 100 natural numbers, then the probability that all three of them are divisible by both 2 and 3, is
(2004, 1M)

- (a) $\frac{4}{55}$ (b) $\frac{4}{35}$ (c) $\frac{4}{33}$ (d) $\frac{4}{1155}$

12. Two numbers are selected randomly from the set $S = \{1, 2, 3, 4, 5, 6\}$ without replacement one by one. The probability that minimum of the two numbers is less than 4, is
(2003, 1M)

- (a) 1/15 (b) 14/15 (c) 1/5 (d) 4/5

13. If the integers m and n are chosen at random between 1 and 100, then the probability that a number of the form $7^m + 7^n$ is divisible by 5, equals
(1999, 2M)

- (a) $\frac{1}{4}$ (b) $\frac{1}{7}$ (c) $\frac{1}{8}$ (d) $\frac{1}{49}$

14. Seven white balls and three black balls are randomly placed in a row. The probability that no two black balls are placed adjacently, equals
(1998, 2M)

- (a) $\frac{1}{2}$ (b) $\frac{7}{15}$ (c) $\frac{2}{15}$ (d) $\frac{1}{3}$

104 Probability

15. Three of the six vertices of a regular hexagon are chosen at random. The probability that the triangle with three vertices is equilateral, equals (1995, 2M)
(a) $1/2$ (b) $1/5$ (c) $1/10$ (d) $1/20$
16. Three identical dice are rolled. The probability that the same number will appear on each of them, is (1984, 2M)
(a) $\frac{1}{6}$ (b) $\frac{1}{36}$ (c) $\frac{1}{18}$ (d) $\frac{3}{28}$
17. Fifteen coupons are numbered 1, 2, ..., 15, respectively. Seven coupons are selected at random one at a time with replacement. The probability that the largest number appearing on a selected coupon is 9, is
(a) $\left(\frac{9}{16}\right)^6$ (b) $\left(\frac{8}{15}\right)^7$ (c) $\left(\frac{3}{5}\right)^7$ (d) None of these

Assertion and Reason

For the following questions, choose the correct answer from the codes (a), (b), (c) and (d) defined as follows.

- (a) Statement I is true, Statement II is also true; Statement II is the correct explanation of Statement I
(b) Statement I is true, Statement II is also true; Statement II is not the correct explanation of Statement I
(c) Statement I is true; Statement II is false
(d) Statement I is false; Statement II is true
18. Consider the system of equations

$$ax + by = 0, cx + dy = 0,$$

where $a, b, c, d \in \{0, 1\}$.

Statement I The probability that the system of equations has a unique solution, is $3/8$.

Statement II The probability that the system of equations has a solution, is 1. (2008, 3M)

Passage Based Problems

Passage

Box I contains three cards bearing numbers 1, 2, 3; box II contains five cards bearing numbers 1, 2, 3, 4, 5; and box III contains seven cards bearing numbers 1, 2, 3, 4, 5, 6, 7. A card is drawn from each of the boxes. Let x_i be the number on the card drawn from the i th box $i = 1, 2, 3$. (2014 Adv.)

19. The probability that $x_1 + x_2 + x_3$ is odd, is
(a) $\frac{29}{105}$ (b) $\frac{53}{105}$ (c) $\frac{57}{105}$ (d) $\frac{1}{2}$
20. The probability that x_1, x_2 and x_3 are in an arithmetic progression, is
(a) $\frac{9}{105}$ (b) $\frac{10}{105}$ (c) $\frac{11}{105}$ (d) $\frac{7}{105}$

Fill in the Blanks

21. Three faces of a fair die are yellow, two faces red and one face blue. The die is tossed three times. The probability that the colours, yellow, red and blue, appear in the first, second and the third tosses respectively, is..... (1992, 2M)
22. If $\frac{1+3p}{3}$, $\frac{1-p}{4}$ and $\frac{1-2p}{2}$ are the probabilities of three mutually exclusive events, then the set of all values of p is... (1986, 2M)
23. A determinant is chosen at random from the set of all determinants of order 2 with elements 0 or 1 only. The probability that the value of the determinant chosen is positive, is... (1982, 2M)

True/False

24. If the letters of the word 'ASSASSIN' are written down at random in a row, the probability that no two S's occur together is $1/35$.

Analytical and Descriptive Questions

25. An unbiased die, with faces numbered 1, 2, 3, 4, 5 and 6 is thrown n times and the list of n numbers showing up is noted. What is the probability that among the numbers 1, 2, 3, 4, 5 and 6 only three numbers appear in this list? (2001, 5M)
26. If p and q are chosen randomly from the set $\{1, 2, 3, 4, 5, 6, 7, 8, 9$ and $10\}$ with replacement, determine the probability that the roots of the equation $x^2 + px + q = 0$ are real. (1997, 5M)
27. In how many ways three girls and nine boys can be seated in two vans, each having numbered seats, 3 in the front and 4 at the back? How many seating arrangements are possible if 3 girls should sit together in a back row on adjacent seats? Now, if all the seating arrangements are equally likely, what is the probability of 3 girls sitting together in a back row on adjacent seats? (1996, 5M)
28. A box contains 2 fifty paise coins, 5 twenty five paise coins and a certain fixed number n (≥ 2) of ten and five paise coins. Five coins are taken out of the box at random. Find the probability that the total value of these 5 coins is less than one rupee and fifty paise. (1988, 3M)
29. Six boys and six girls sit in a row at random. Find the probability that
(i) the six girls sit together.
(ii) the boys and girls sit alternatively. (1978, 3M)

Topic 2 Addition and Subtraction Law of Probability

Objective Questions I (Only one correct option)

1. The probabilities of three events A , B and C are given by $P(A) = 0.6$, $P(B) = 0.4$ and $P(C) = 0.5$. If $P(A \cup B) = 0.8$, $P(A \cap C) = 0.3$, $P(A \cap B \cap C) = 0.2$, $P(B \cap C) = \beta$ and $P(A \cup B \cup C) = \alpha$, where $0.85 \leq \alpha \leq 0.95$, then β lies in the interval

(2020 Main, 6 Sep II)

- (a) [0.35, 0.36] (b) [0.25, 0.35]
(c) [0.20, 0.25] (d) [0.36, 0.40]
2. For three events A , B and C , if $P(\text{exactly one of } A \text{ or } B \text{ occurs}) = P(\text{exactly one of } B \text{ or } C \text{ occurs}) = P(\text{exactly one of } C \text{ or } A \text{ occurs}) = \frac{1}{4}$ and $P(\text{all the three events occur simultaneously}) = \frac{1}{16}$, then the probability that atleast one of the events occurs, is

(2017 Main)

- (a) $\frac{7}{32}$ (b) $\frac{7}{16}$ (c) $\frac{7}{64}$ (d) $\frac{3}{16}$
3. If $P(B) = \frac{3}{4}$, $P(A \cap B \cap \bar{C}) = \frac{1}{3}$ and $P(\bar{A} \cap B \cap \bar{C}) = \frac{1}{3}$, then $P(B \cap C)$ is equal to

(2002, 3M)

- (a) $\frac{1}{12}$ (b) $\frac{1}{6}$ (c) $\frac{1}{15}$ (d) $\frac{1}{9}$
4. If E and F are events with $P(E) \leq P(F)$ and $P(E \cap F) > 0$, then which one is not correct? (1998, 2M)
- (a) occurrence of $E \Rightarrow$ occurrence of F
(b) occurrence of $F \Rightarrow$ occurrence of E
(c) non-occurrence of $E \Rightarrow$ non-occurrence of F
(d) None of the above

5. For the three events A , B and C , $P(\text{exactly one of the events } A \text{ or } B \text{ occurs}) = P(\text{exactly one of the events } B \text{ or } C \text{ occurs}) = P(\text{exactly one of the events } C \text{ or } A \text{ occurs}) = p$ and $P(\text{all the three events occurs simultaneously}) = p^2$, where $0 < p < \frac{1}{2}$. Then, the probability of atleast one of the three events A , B and C occurring is

(1996, 2M)

- (a) $\frac{3p + 2p^2}{2}$ (b) $\frac{p + 3p^2}{4}$
(c) $\frac{p + 3p^2}{2}$ (d) $\frac{3p + 2p^2}{4}$
6. If $0 < P(A) < 1$, $0 < P(B) < 1$ and $P(A \cup B) = P(A) + P(B) - P(A)P(B)$, then (1995, 2M)
- (a) $P(B|A) = P(B) - P(A)$
(b) $P(A' - B') = P(A') - P(B')$
(c) $P(A \cup B)' = P(A)'P(B)'$
(d) $P(A|B) = P(A) - P(B)$

7. The probability that at least one of the events A and B occurs is 0.6. If A and B occur simultaneously with probability 0.2, then $P(\bar{A}) + P(\bar{B})$ is equal to

(1987, 2M)

- (a) 0.4 (b) 0.8 (c) 1.2 (d) 1.4

8. Two events A and B have probabilities 0.25 and 0.50, respectively. The probability that both A and B occur simultaneously is 0.14. Then, the probability that neither A nor B occurs, is (1980, 1M)

- (a) 0.39 (b) 0.25
(c) 0.11 (d) None of these

Objective Questions II

(One or more than one correct option)

9. For two given events A and B , $P(A \cap B)$ is (1988, 2M)
- (a) not less than $P(A) + P(B) - 1$
(b) not greater than $P(A) + P(B)$
(c) equal to $P(A) + P(B) - P(A \cup B)$
(d) equal to $P(A) + P(B) + P(A \cup B)$

10. If M and N are any two events, then the probability that exactly one of them occurs is (1984, 3M)
- (a) $P(M) + P(N) - 2P(M \cap N)$
(b) $P(M) + P(N) - P(\overline{M \cup N})$
(c) $P(\overline{M}) + P(\overline{N}) - 2P(\overline{M} \cap \overline{N})$
(d) $P(M \cap \overline{N}) - P(\overline{M} \cap N)$

Fill in the Blanks

11. Three numbers are chosen at random without replacement from $\{1, 2, \dots, 10\}$. The probability that the minimum of the chosen number is 3, or their maximum is 7, is ... (1997C, 2M)
12. $P(A \cup B) = P(A \cap B)$ if and only if the relation between $P(A)$ and $P(B)$ is... (1985, 2M)

True/False

13. If the probability for A to fail in an examination is 0.2 and that of B is 0.3, then the probability that either A or B fails is 0.5. (1989, 1M)

Analytical and Descriptive Questions

14. In a certain city only two newspapers A and B are published, it is known that 25% of the city population reads A and 20% reads B , while 8% reads both A and B . It is also known that 30% of those who read A but not B look into advertisements and 40% of those who read B but not A look into advertisements while 50% of those who read both A and B look into advertisements. What is the percentage of the population reads an advertisement? (1984, 4M)

15. A , B , C are events such that
 $P_r(A) = 0.3$, $P_r(B) = 0.4$, $P_r(C) = 0.8$,
 $P_r(AB) = 0.08$, $P_r(AC) = 0.28$ and $P_r(ABC) = 0.09$
If $P_r(A \cup B \cup C) \geq 0.75$, then show that $P_r(BC)$ lies in the interval $[0.23, 0.48]$. (1983, 2M)

16. A and B are two candidates seeking admission in IIT. The probability that A is selected is 0.5 and the probability that both A and B are selected is atmost 0.3. Is it possible that the probability of B getting selected is 0.9? (1982, 2M)

Paragraph Based Questions

There are five students S_1, S_2, S_3, S_4 and S_5 in a music class and for them there are five seats R_1, R_2, R_3, R_4 and R_5 arranged in a row, where initially the seat R_i is allotted to the student $S_i, i = 1, 2, 3, 4, 5$. But, on the examination day, the five students are randomly allotted the five seats.

(There are two questions based on Paragraph, the question given below is one of them) (2018 Adv.)

17. The probability that, on the examination day, the student S_1 gets the previously allotted seat R_1 , and

NONE of the remaining students gets the seat previously allotted to him/her is

- (a) $\frac{3}{40}$ (b) $\frac{1}{8}$ (c) $\frac{7}{40}$ (d) $\frac{1}{5}$

18. For $i = 1, 2, 3, 4$, let T_i denote the event that the students S_i and S_{i+1} do NOT sit adjacent to each other on the day of the examination. Then, the probability of the event $T_1 \cap T_2 \cap T_3 \cap T_4$ is

- (a) $\frac{1}{15}$ (b) $\frac{1}{10}$ (c) $\frac{7}{60}$ (d) $\frac{1}{5}$

Topic 3 Independent and Conditional Probability

Objective Questions I (Only one correct option)

1. Assume that each born child is equally likely to be a boy or a girl. If two families have two children each, then the conditional probability that all children are girls given that at least two are girls; is (2019 Main, 10 April I)

- (a) $\frac{1}{17}$ (b) $\frac{1}{12}$ (c) $\frac{1}{10}$ (d) $\frac{1}{11}$

2. Four persons can hit a target correctly with probabilities $\frac{1}{2}, \frac{1}{3}, \frac{1}{4}$ and $\frac{1}{8}$ respectively. If all hit at the target independently, then the probability that the target would be hit, is (2019 Main, 9 April I)

- (a) $\frac{1}{192}$ (b) $\frac{25}{32}$ (c) $\frac{7}{32}$ (d) $\frac{25}{192}$

3. Let A and B be two non-null events such that $A \subset B$. Then, which of the following statements is always correct. (2019 Main, 8 April I)

- (a) $P(A/B) = P(B) - P(A)$ (b) $P(A/B) \geq P(A)$
(c) $P(A/B) \leq P(A)$ (d) $P(A/B) = 1$

4. Two integers are selected at random from the set $\{1, 2, \dots, 11\}$. Given that the sum of selected numbers is even, the conditional probability that both the numbers are even is (2019 Main, 11 Jan I)

- (a) $\frac{2}{5}$ (b) $\frac{1}{2}$ (c) $\frac{7}{10}$ (d) $\frac{3}{5}$

5. An unbiased coin is tossed. If the outcome is a head, then a pair of unbiased dice is rolled and the sum of the numbers obtained on them is noted. If the toss of the coin results in tail, then a card from a well-shuffled pack of nine cards numbered 1, 2, 3, ..., 9 is randomly picked and the number on the card is noted. The probability that the noted number is either 7 or 8 is (2019 Main, 10 Jan I)

- (a) $\frac{15}{72}$ (b) $\frac{13}{36}$ (c) $\frac{19}{72}$ (d) $\frac{19}{36}$

6. Let two fair six-faced dice A and B be thrown simultaneously. If E_1 is the event that die A shows up four, E_2 is the event that die B shows up two and E_3 is the event that the sum of numbers on both dice is odd, then which of the following statements is not true? (2016 Main)

- (a) E_1 and E_2 are independent
(b) E_2 and E_3 are independent
(c) E_1 and E_3 are independent
(d) E_1, E_2 and E_3 are independent

7. Let A and B be two events such that $P(\overline{A \cup B}) = \frac{1}{6}$, $P(A \cap B) = \frac{1}{4}$ and $P(\overline{A}) = \frac{1}{4}$, where \overline{A} stands for the complement of the event A . Then, the events A and B are (2014 Main)

- (a) independent but not equally likely
(b) independent and equally likely
(c) mutually exclusive and independent
(d) equally likely but not independent

8. Four persons independently solve a certain problem correctly with probabilities $\frac{1}{2}, \frac{3}{4}, \frac{1}{4}, \frac{1}{8}$. Then, the probability that the problem is solved correctly by atleast one of them, is (2013 Adv.)

- (a) $\frac{235}{256}$ (b) $\frac{21}{256}$
(c) $\frac{3}{256}$ (d) $\frac{253}{256}$

9. An experiment has 10 equally likely outcomes. Let A and B be two non-empty events of the experiment. If A consists of 4 outcomes, then the number of outcomes that B must have, so that A and B are independent, is

- (a) 2, 4 or 8 (b) 3, 6 or 9 (2008, 3M)
(c) 4 or 8 (d) 5 or 10

10. Let E^c denotes the complement of an event E . If E, F, G are pairwise independent events with $P(G) > 0$ and $P(E \cap F \cap G) = 0$. Then, $P(E^c \cap F^c | G)$ equals (2007, 3M)

- (a) $P(E^c) + P(F^c)$ (b) $P(E^c) - P(F^c)$
(c) $P(E^c) - P(F)$ (d) $P(E) - P(F^c)$

11. One Indian and four American men and their wives are to be seated randomly around a circular table. Then, the conditional probability that Indian man is seated adjacent to his wife given that each American man is seated adjacent to his wife, is (2007, 3M)

- (a) $\frac{1}{2}$ (b) $\frac{1}{3}$ (c) $\frac{2}{5}$ (d) $\frac{1}{5}$

12. A fair die is rolled. The probability that the first time 1 occurs at the even throw, is (2005, 1M)
(a) $1/6$ (b) $5/11$ (c) $6/11$ (d) $5/36$
13. There are four machines and it is known that exactly two of them are faulty. They are tested, one by one, in a random order till both the faulty machines are identified. Then, the probability that only two tests are needed, is (1998, 2M)
(a) $\frac{1}{3}$ (b) $\frac{1}{6}$ (c) $\frac{1}{2}$ (d) $\frac{1}{4}$
14. A fair coin is tossed repeatedly. If tail appears on first four tosses, then the probability of head appearing on fifth toss equals (1998, 2M)
(a) $\frac{1}{2}$ (b) $\frac{1}{32}$ (c) $\frac{31}{32}$ (d) $\frac{1}{5}$
15. If from each of the three boxes containing 3 white and 1 black, 2 white and 2 black, 1 white and 3 black balls, one ball is drawn at random, then the probability that 2 white and 1 black balls will be drawn, is (1998, 2M)
(a) $\frac{13}{32}$ (b) $\frac{1}{4}$ (c) $\frac{1}{32}$ (d) $\frac{3}{16}$
16. The probability of India winning a test match against West Indies is $1/2$. Assuming independence from match to match the probability that in a 5 match series India's second win occurs at third test, is (1995, 2M)
(a) $1/8$ (b) $1/4$ (c) $1/2$ (d) $2/3$
17. An unbiased die with faces marked 1, 2, 3, 4, 5 and 6 is rolled four times. Out of four face values obtained, the probability that the minimum face value is not less than 2 and the maximum face value is not greater than 5, is (1993, 1M)
(a) $16/81$ (b) $1/81$ (c) $80/81$ (d) $65/81$
18. A student appears for tests I, II and III. The student is successful if he passes either in tests I and II or tests I and III. The probabilities of the student passing in tests I, II and III are p , q and $\frac{1}{2}$, respectively. If the probability that the student is successful, is $\frac{1}{2}$, then (1986, 2M)
(a) $p = q = 1$ (b) $p = q = \frac{1}{2}$
(c) $p = 1, q = 0$ (d) $p = 1, q = \frac{1}{2}$
19. If A and B are two independent events such that $P(A) > 0$, and $P(B) \neq 1$, then $P(\bar{A}/\bar{B})$ is equal to (1982, 2M)
(a) $1 - P(A/B)$ (b) $1 - P(A/\bar{B})$
(c) $\frac{1 - P(A \cup B)}{P(B)}$ (d) $\frac{P(\bar{A})}{P(\bar{B})}$
20. The probability that an event A happens in one trial of an experiment, is 0.4. Three independent trials of the experiments are performed. The probability that the event A happens atleast once, is (1980, 1M)
(a) 0.936 (b) 0.784
(c) 0.904 (d) None of these

Objective Questions II

(One or more than one correct option)

21. Let X and Y be two events such that $P(X) = \frac{1}{3}$, $P(X/Y) = \frac{1}{2}$ and $P(Y/X) = \frac{2}{5}$. Then (2017 Adv.)
(a) $P(Y) = \frac{4}{15}$ (b) $P(X'/Y) = \frac{1}{2}$
(c) $P(X \cup Y) = \frac{2}{5}$ (d) $P(X \cap Y) = \frac{1}{5}$
22. If X and Y are two events such that $P(X/Y) = \frac{1}{2}$, $P(Y/X) = \frac{1}{3}$ and $P(X \cap Y) = \frac{1}{6}$. Then, which of the following is/are correct? (2012)
(a) $P(X \cup Y) = 2/3$
(b) X and Y are independent
(c) X and Y are not independent
(d) $P(X^c \cap Y) = 1/3$
23. Let E and F be two independent events. The probability that exactly one of them occurs is $\frac{11}{25}$ and the probability of none of them occurring is $\frac{2}{25}$. If $P(T)$ denotes the probability of occurrence of the event T , then (2011)
(a) $P(E) = \frac{4}{5}$, $P(F) = \frac{3}{5}$ (b) $P(E) = \frac{1}{5}$, $P(F) = \frac{2}{5}$
(c) $P(E) = \frac{2}{5}$, $P(F) = \frac{1}{5}$ (d) $P(E) = \frac{3}{5}$, $P(F) = \frac{4}{5}$
24. The probabilities that a student passes in Mathematics, Physics and Chemistry are m , p and c , respectively. Of these subjects, the students has a 75% chance of passing in atleast one, a 50% chance of passing in atleast two and a 40% chance of passing in exactly two. Which of the following relations are true? (1999, 3M) (2011)
(a) $p + m + c = \frac{19}{20}$ (b) $p + m + c = \frac{27}{20}$
(c) $pmc = \frac{1}{10}$ (d) $pmc = \frac{1}{4}$
25. If \bar{E} and \bar{F} are the complementary events of E and F respectively and if $0 < P(F) < 1$, then (1998, 2M)
(a) $P(E/F) + P(\bar{E}/F) = 1$ (b) $P(E/F) + P(E/\bar{F}) = 1$
(c) $P(\bar{E}/F) + P(E/\bar{F}) = 1$ (d) $P(E/\bar{F}) + P(\bar{E}/\bar{F}) = 1$
26. Let E and F be two independent events. If the probability that both E and F happen is $1/12$ and the probability that neither E nor F happen is $1/2$. Then, (1993, 2M)
(a) $P(E) = 1/3$, $P(F) = 1/4$
(b) $P(E) = 1/2$, $P(F) = 1/6$
(c) $P(E) = 1/6$, $P(F) = 1/2$
(d) $P(E) = 1/4$, $P(F) = 1/3$
27. For any two events A and B in a sample space (1991, 2M)
(a) $P\left(\frac{A}{B}\right) \geq \frac{P(A) + P(B) - 1}{P(B)}$, $P(B) \neq 0$ is always true
(b) $P(A \cap \bar{B}) = P(A) - P(A \cap B)$ does not hold
(c) $P(A \cup B) = 1 - P(\bar{A})P(\bar{B})$, if A and B are independent
(d) $P(A \cup B) = 1 - P(\bar{A})P(\bar{B})$, if A and B are disjoint

108 Probability

28. If E and F are independent events such that $0 < P(E) < 1$ and $0 < P(F) < 1$, then (1989, 2M)
- E and F are mutually exclusive
 - E and F^c (the complement of the event F) are independent
 - E^c and F^c are independent
 - $P(E/F) + P(E^c/F) = 1$

Fill in the Blanks

29. If two events A and B are such that $P(A^c) = 0.3$, $P(B) = 0.4$ and $P(A \cap B^c) = 0.5$, then $P[B/(A \cup B^c)] = \dots$ (1994, 2M)
30. Let A and B be two events such that $P(A) = 0.3$ and $P(A \cup B) = 0.8$. If A and B are independent events, then $P(B) = \dots$ (1990, 2M)
31. A pair of fair dice is rolled together till a sum of either 5 or 7 is obtained. Then, the probability that 5 comes before 7, is... (1989, 2M)
32. Urn A contains 6 red and 4 black balls and urn B contains 4 red and 6 black balls. One ball is drawn at random from urn A and placed in urn B . Then, one ball is drawn at random from urn B and placed in urn A . If one ball is drawn at random from urn A , the probability that it is found to be red, is... (1988, 2M)
33. A box contains 100 tickets numbered 1, 2, ..., 100. Two tickets are chosen at random. It is given that the maximum number on the two chosen tickets is not more than 10. The maximum number on them is 5 with probability... (1985, 2M)

Analytical and Descriptive Questions

34. If A and B are two independent events, prove that $P(A \cup B) \cdot P(A' \cap B') \leq P(C)$, where C is an event defined that exactly one of A and B occurs. (2004, 2M)
35. A is targeting to B , B and C are targeting to A . Probability of hitting the target by A , B and C are $\frac{2}{3}$, $\frac{1}{2}$ and $\frac{1}{3}$, respectively. If A is hit, then find the probability that B hits the target and C does not. (2003, 2M)
36. For a student to qualify, he must pass at least two out of three exams. The probability that he will pass the 1st exam is p . If he fails in one of the exams, then the probability of his passing in the next exam, is $\frac{p}{2}$ otherwise it remains the same. Find the probability that he will qualify. (2003, 2M)
37. A coin has probability p of showing head when tossed. It is tossed n times. Let p_n denotes the probability that no two (or more) consecutive heads occur. Prove that $p_1 = 1$, $p_2 = 1 - p^2$ and $p_n = (1 - p) \cdot p_{n-1} + p(1 - p)p_{n-2}$, $\forall n \geq 3$. (2000, 5M)
38. An unbiased coin is tossed. If the result in a head, a pair of unbiased dice is rolled and the number obtained by adding the numbers on the two faces is noted. If the

result is a tail, a card from a well-shuffled pack of eleven cards numbered 2, 3, 4, ..., 12 is picked and the number on the card is noted. What is the probability that the noted number is either 7 or 8? (1994, 5M)

39. A lot contains 50 defective and 50 non-defective bulbs. Two bulbs are drawn at random, one at a time, with replacement. The events A , B , C are defined as :
 $A =$ (the first bulb is defective)
 $B =$ (the second bulb is non-defective)
 $C =$ (the two bulbs are both defective or both non-defective).

Determine whether

- A , B , C are pairwise independent.
 - A , B , C are independent. (1992, 6M)
40. In a multiple-choice question there are four alternative answers, of which one or more are correct. A candidate will get marks in the question only if he ticks the correct answers. The candidates decide to tick the answers at random, if he is allowed upto three chances to answer the questions, find the probability that he will get marks in the question. (1985, 5M)
41. A and B are two independent events. The probability that both A and B occur is $\frac{1}{6}$ and the probability that neither of them occurs is $\frac{1}{3}$. Find the probability of the occurrence of A . (1984, 2M)
42. Cards are drawn one by one at random from a well shuffled full pack of 52 playing cards until 2 aces are obtained for the first time. If N is the number of cards required to be drawn, then show that
- $$P_r \{N = n\} = \frac{(n-1)(52-n)(51-n)}{50 \times 49 \times 17 \times 13}$$
- where, $2 < n \leq 50$. (1983, 3M)
43. An anti-aircraft gun can take a maximum of four shots at an enemy plane moving away from it. The probabilities of hitting the plane at the first, second, third and fourth shot are 0.4, 0.3, 0.2, and 0.1, respectively. What is the probability that the gun hits the plane? (1981, 2M)
44. A box contains 2 black, 4 white and 3 red balls. One ball is drawn at random from the box and kept aside. From the remaining balls in the box, another ball is drawn at random and kept beside the first. This process is repeated till all the balls are drawn from the box. Find the probability that the balls drawn are in the sequence of 2 black, 4 white and 3 red. (1979, 2M)

Integer & Numerical Answer Type Questions

45. Let S be the sample space of all 3×3 matrices with entries from the set $\{0, 1\}$. Let the events E_1 and E_2 be given by
 $E_1 = \{A \in S : \det A = 0\}$ and
 $E_2 = \{A \in S : \text{sum of entries of } A \text{ is } 7\}$.
 If a matrix is chosen at random from S , then the conditional probability $P(E_1 | E_2)$ equals

46. Of the three independent events E_1, E_2 and E_3 , the probability that only E_1 occurs is α , only E_2 occurs is β and only E_3 occurs is γ . Let the probability p that none of events E_1, E_2 or E_3 occurs satisfy the equations $(\alpha - 2\beta)$, $p = \alpha\beta$ and $(\beta - 3\gamma) p = 2\beta\gamma$. All the given probabilities are assumed to lie in the interval $(0, 1)$.

Then, $\frac{\text{probability of occurrence of } E_1}{\text{probability of occurrence of } E_3}$ is equal to

Passage Type Questions

Passage

Football teams T_1 and T_2 have to play two games against each other. It is assumed that the outcomes of the two games are independent. The probabilities of T_1 winning, drawing and

losing a game against T_2 are $\frac{1}{2}$, $\frac{1}{6}$ and $\frac{1}{3}$, respectively. Each team gets 3 points for a win, 1 point for a draw and 0 point for a loss in a game. Let X and Y denote the total points scored by teams T_1 and T_2 , respectively, after two games. (2016 Adv.)

47. $P(X > Y)$ is

- (a) $\frac{1}{4}$ (b) $\frac{5}{12}$
(c) $\frac{1}{2}$ (d) $\frac{7}{12}$

48. $P(X = Y)$ is

- (a) $\frac{11}{36}$ (b) $\frac{1}{3}$
(c) $\frac{13}{36}$ (d) $\frac{1}{2}$

Topic 4 Law of Total Probability and Baye's Theorem

Objective Question I (Only one correct option)

1. A pot contain 5 red and 2 green balls. At random a ball is drawn from this pot. If a drawn ball is green then put a red ball in the pot and if a drawn ball is red, then put a green ball in the pot, while drawn ball is not replace in the pot. Now we draw another ball randomly, the probability of second ball to be red is (2019 Main, 9 Jan II)

- (a) $\frac{27}{49}$ (b) $\frac{26}{49}$ (c) $\frac{21}{49}$ (d) $\frac{32}{49}$

2. A bag contains 4 red and 6 black balls. A ball is drawn at random from the bag, its colour is observed and this ball along with two additional balls of the same colour are returned to the bag. If now a ball is drawn at random from the bag, then the probability that this drawn ball is red, is (2018 Main)

- (a) $\frac{3}{10}$ (b) $\frac{2}{5}$
(c) $\frac{1}{5}$ (d) $\frac{3}{4}$

3. A computer producing factory has only two plants T_1 and T_2 . Plant T_1 produces 20% and plant T_2 produces 80% of the total computers produced. 7% of computers produced in the factory turn out to be defective. It is known that $P(\text{computer turns out to be defective, given that it is produced in plant } T_1) = 10P(\text{computer turns out to be defective, given that it is produced in plant } T_2)$, where $P(E)$ denotes the probability of an event E . A computer produced in the factory is randomly selected and it does not turn out to be defective. Then, the probability that it is produced in plant T_2 , is (2016 Adv.)

- (a) $\frac{36}{73}$ (b) $\frac{47}{79}$
(c) $\frac{78}{93}$ (d) $\frac{75}{83}$

4. A signal which can be green or red with probability $\frac{4}{5}$ and $\frac{1}{5}$ respectively, is received by station A and then

transmitted to station B . The probability of each station receiving the signal correctly is $\frac{3}{4}$. If the signal received

at station B is green, then the probability that the original signal green is (2010)

- (a) $\frac{3}{5}$ (b) $\frac{6}{7}$
(c) $\frac{20}{23}$ (d) $\frac{9}{20}$

Objective Question II

(One or more than one correct option)

5. There are three bags B_1, B_2 and B_3 . The bag B_1 contains 5 red and 5 green balls, B_2 contains 3 red and 5 green balls, and B_3 contains 5 red and 3 green balls. Bags B_1, B_2 and B_3 have probabilities $\frac{3}{10}, \frac{3}{10}$ and $\frac{4}{10}$ respectively

of being chosen. A bag is selected at random and a ball is chosen at random from the bag. Then which of the following options is/are correct?

- (a) Probability that the chosen ball is green, given that the selected bag is B_3 , equals $\frac{3}{8}$.
(b) Probability that the selected bag is B_3 , given that the chosen ball is green, equals $\frac{5}{13}$.
(c) Probability that the chosen ball is green equals $\frac{39}{80}$.
(d) Probability that the selected bag is B_3 and the chosen ball is green equals $\frac{3}{10}$.

6. A ship is fitted with three engines E_1, E_2 and E_3 . The engines function independently of each other with respective probabilities $1/2, 1/4$ and $1/4$. For the ship to be operational at least two of its engines must function. Let X denotes the event that the ship is operational and let X_1, X_2 and X_3 denote, respectively the events that the engines E_1, E_2 and E_3 are functioning.

110 Probability

Which of the following is/are true? (2012)

- (a) $P[X_1^c | X] = 3/16$
 (b) $P[\text{exactly two engines of the ship are functioning}] = \frac{7}{8}$
 (c) $P[X | X_2] = \frac{5}{16}$ (d) $P[X | X_1] = \frac{7}{16}$

Assertion and Reason

For the following questions, choose the correct answer from the codes (a), (b), (c) and (d) defined as follows.

- (a) Statement I is true, Statement II is also true; Statement II is the correct explanation of Statement I
 (b) Statement I is true, Statement II is also true; Statement II is not the correct explanation of Statement I
 (c) Statement I is true; Statement II is false
 (d) Statement I is false; Statement II is true

7. Let H_1, H_2, \dots, H_n be mutually exclusive events with $P(H_i) > 0, i = 1, 2, \dots, n$. Let E be any other event with $0 < P(E) < 1$.

Statement I $P(H_i|E) > P(E|H_i) \cdot P(H_i)$ for $i = 1, 2, \dots, n$

Statement II $\sum_{i=1}^n P(H_i) = 1$ (2007, 3M)

Passage Based Problems

Passage I

Let n_1 and n_2 be the number of red and black balls, respectively in box I. Let n_3 and n_4 be the number of red and black balls, respectively in box II. (2015 Adv.)

8. One of the two boxes, box I and box II was selected at random and a ball was drawn randomly out of this box. The ball was found to be red. If the probability that this red ball was drawn from box II, is $\frac{1}{3}$, then the correct

option(s) with the possible values of n_1, n_2, n_3 and n_4 is/are

- (a) $n_1 = 3, n_2 = 3, n_3 = 5, n_4 = 15$
 (b) $n_1 = 3, n_2 = 6, n_3 = 10, n_4 = 50$
 (c) $n_1 = 8, n_2 = 6, n_3 = 5, n_4 = 20$
 (d) $n_1 = 6, n_2 = 12, n_3 = 5, n_4 = 20$
9. A ball is drawn at random from box I and transferred to box II. If the probability of drawing a red ball from box I, after this transfer, is $\frac{1}{3}$, then the correct option(s) with

the possible values of n_1 and n_2 is/are

- (a) $n_1 = 4$ and $n_2 = 6$ (b) $n_1 = 2$ and $n_2 = 3$
 (c) $n_1 = 10$ and $n_2 = 20$ (d) $n_1 = 3$ and $n_2 = 6$

Passage II

Let U_1 and U_2 be two urns such that U_1 contains 3 white and 2 red balls and U_2 contains only 1 white ball. A fair coin is tossed. If head appears then 1 ball is drawn at random from U_1 and put into U_2 . However, if tail appears then 2 balls are drawn at random from U_1 and put into U_2 . Now, 1 ball is drawn at random from U_2 . (2011)

10. The probability of the drawn ball from U_2 being white, is

- (a) $\frac{13}{30}$ (b) $\frac{23}{30}$ (c) $\frac{19}{30}$ (d) $\frac{11}{30}$

11. Given that the drawn ball from U_2 is white, the probability that head appeared on the coin is

- (a) $\frac{17}{23}$ (b) $\frac{11}{23}$ (c) $\frac{15}{23}$ (d) $\frac{12}{23}$

Passage III

A fair die is tossed repeatedly until a six is obtained. Let X denote the number of tosses required. (2009)

12. The probability that $X = 3$ equals

- (a) $\frac{25}{216}$ (b) $\frac{25}{36}$ (c) $\frac{5}{36}$ (d) $\frac{125}{216}$

13. The probability that $X \geq 3$ equals

- (a) $\frac{125}{216}$ (b) $\frac{25}{36}$ (c) $\frac{5}{36}$ (d) $\frac{25}{216}$

14. The conditional probability that $X \geq 6$ given $X > 3$ equals

- (a) $\frac{125}{216}$ (b) $\frac{25}{216}$ (c) $\frac{5}{36}$ (d) $\frac{25}{36}$

Passage IV

There are n urns each containing $(n+1)$ balls such that the i th urn contains i white balls and $(n+1-i)$ red balls. Let u_i be the event of selecting i th urn, $i = 1, 2, 3, \dots, n$ and W denotes the event of getting a white balls. (2006, 5M)

15. If $P(u_i) \propto i$, where $i = 1, 2, 3, \dots, n$, then $\lim_{n \rightarrow \infty} P(W)$ is equal to

- (a) 1 (b) $\frac{2}{3}$ (c) $\frac{1}{4}$ (d) $\frac{3}{4}$

16. If $P(u_i) = c$, where c is a constant, then $P(u_n | W)$ is equal to

- (a) $\frac{2}{n+1}$ (b) $\frac{1}{n+1}$
 (c) $\frac{n}{n+1}$ (d) $\frac{1}{2}$

17. If n is even and E denotes the event of choosing even numbered urn $\left[P(u_i) = \frac{1}{n} \right]$, then the value of $P(W|E)$ is

- (a) $\frac{n+2}{2n+1}$ (b) $\frac{n+2}{2(n+1)}$
 (c) $\frac{n}{n+1}$ (d) $\frac{1}{n+1}$

Analytical and Descriptive Questions

18. A person goes to office either by car, scooter, bus or train probability of which being $\frac{1}{7}, \frac{3}{7}, \frac{2}{7}$ and $\frac{1}{7}$ respectively. Probability that he reaches offices late, if he takes car, scooter, bus or train is $\frac{2}{9}, \frac{1}{9}, \frac{4}{9}$ and $\frac{1}{9}$ respectively. Given that he reached office in time, then what is the probability that he travelled by a car? (2005, 2M)

19. A bag contains 12 red balls and 6 white balls. Six balls are drawn one by one without replacement of which at least 4 balls are white. Find the probability that in the next two drawn exactly one white ball is drawn. (Leave the answer in ${}^n C_r$). (2004, 4M)
20. A box contains N coins, m of which are fair and the rest are biased. The probability of getting a head when a fair coin is tossed, is $1/2$, while it is $2/3$ when a biased coin is tossed. A coin is drawn from the box at random and is tossed twice. The first time it shows head and the second time it shows tail. What is the probability that the coin drawn is fair? (2002, 5M)
21. An urn contains m white and n black balls. A ball is drawn at random and is put back into the urn along with k additional balls of the same colour as that of the ball drawn. A ball is again drawn at random. What is the probability that the ball drawn now is white? (2001, 5M)
22. Eight players P_1, P_2, \dots, P_8 play a knock-out tournament. It is known that whenever the players P_i and P_j play, the player P_i will win if $i < j$. Assuming that the players are paired at random in each round, what is the probability that the player P_4 reaches the final? (1999, 10M)
23. Three players, A, B and C , toss a coin cyclically in that order (i.e. $A, B, C, A, B, C, A, B, \dots$) till a head shows. Let p be the probability that the coin shows a head. Let α, β and γ be, respectively, the probabilities that A, B and C gets the first head. Prove that $\beta = (1 - p)\alpha$. Determine α, β and γ (in terms of p). (1998, 8M)
24. Sixteen players S_1, S_2, \dots, S_{16} play in a tournament. They are divided into eight pairs at random from each pair a winner is decided on the basis of a game played between the two players of the pair. Assume that all the players are of equal strength.
- (i) Find the probability that the player S_1 is among the eight winners.
- (ii) Find the probability that exactly one of the two players S_1 and S_2 is among the eight winners. (1997C, 5M)
25. In a test an examinee either guesses or copies of knows the answer to a multiple choice question with four choices. The probability that he make a guess is $\frac{1}{3}$ and the probability that he copies the answer is $\frac{1}{6}$. The probability that his answer is correct given that he copied it, is $\frac{1}{8}$. Find the probability that he knew the answer to the question given that he correctly answered it. (1991, 4M)
26. An urn contains 2 white and 2 blacks balls. A ball is drawn at random. If it is white it is not replaced into the urn. Otherwise it is replaced along with another ball of the same colour. The process is repeated. Find the probability that the third ball drawn is black. (1987, 4M)
27. A lot contains 20 articles. The probability that the lot contains exactly 2 defective articles is 0.4 and the probability that the lot contains exactly 3 defective articles is 0.6. Articles are drawn from the lot at random one by one without replacement and are tested till all defective articles are found. What is the probability that the testing procedure ends at the twelfth testing? (1986, 5M)

Topic 5 Probability Distribution and Binomial Distribution

Objective Questions I (Only one correct option)

1. Let C_1 and C_2 be two biased coins such that the probabilities of getting head in a single toss are $\frac{2}{3}$ and $\frac{1}{3}$, respectively. Suppose α is the number of heads that appear when C_1 is tossed twice, independently, and suppose β is the number of heads that appear when C_2 is tossed twice, independently. Then the probability that the roots of the quadratic polynomial $x^2 - \alpha x + \beta$ are real and equal, is (2020 Adv.)
- (a) $\frac{40}{81}$ (b) $\frac{20}{81}$
 (c) $\frac{1}{2}$ (d) $\frac{1}{4}$
2. Four fair dice are thrown independently 27 times. Then, the expected number of times, at least two dice show up a three or a five, is (2020 Main, 5 Sep II)
3. In a workshop, there are five machines and the probability of any one of them to be out of service on a day is $\frac{1}{4}$. If the probability that at most two machines will be out of service on the same day is $\left(\frac{3}{4}\right)^3 k$, then k is equal to (2020 Main, 7 Jan II)
- (a) 4 (b) $\frac{17}{4}$ (c) $\frac{17}{8}$ (d) $\frac{17}{2}$
4. For an initial screening of an admission test, a candidate is given fifty problems to solve. If the probability that the candidate can solve any problem is $\frac{4}{5}$, then the probability that he is unable to solve less than two problem is (2019 Main, 12 April II)
- (a) $\frac{201}{5} \left(\frac{1}{5}\right)^{49}$ (b) $\frac{316}{25} \left(\frac{4}{5}\right)^{48}$
 (c) $\frac{54}{5} \left(\frac{4}{5}\right)^{49}$ (d) $\frac{164}{25} \left(\frac{1}{5}\right)^{48}$
5. Let a random variable X have a binomial distribution with mean 8 and variance 4. If $P(X \leq 2) = \frac{k}{2^{16}}$, then k is equal to (2019 Main, 12 April I)
- (a) 17 (b) 121 (c) 1 (d) 137

112 Probability

6. Minimum number of times a fair coin must be tossed so that the probability of getting atleast one head is more than 99% is (2019 Main 10 April II)
 (a) 8 (b) 6 (c) 7 (d) 5
7. The minimum number of times one has to toss a fair coin so that the probability of observing atleast one head is atleast 90% is (2019 Main, 8 April II)
 (a) 2 (b) 3 (c) 5 (d) 4
8. In a game, a man wins ₹ 100 if he gets 5 or 6 on a throw of a fair die and loses ₹ 50 for getting any other number on the die. If he decides to throw the die either till he gets a five or a six or to a maximum of three throws, then his expected gain/loss (in rupees) is (2019 Main, 12 Jan II)
 (a) $\frac{400}{3}$ loss (b) $\frac{400}{9}$ loss (c) 0 (d) $\frac{400}{3}$ gain
9. If the probability of hitting a target by a shooter in any shot, is $\frac{1}{3}$, then the minimum number of independent shots at the target required by him so that the probability of hitting the target at least once is greater than $\frac{5}{6}$, is (2019 Main, 10 Jan II)
 (a) 6 (b) 3 (c) 5 (d) 4
10. Two cards are drawn successively with replacement from a well shuffled deck of 52 cards. Let X denote the random variable of number of aces obtained in the two drawn cards. Then, $P(X = 1) + P(X = 2)$ equals (2019 Main, 9 Jan I)
 (a) $\frac{25}{169}$ (b) $\frac{52}{169}$ (c) $\frac{49}{169}$ (d) $\frac{24}{169}$
11. A box contains 15 green and 10 yellow balls. If 10 balls are randomly drawn one-by-one with replacement, then the variance of the number of green balls drawn is (2017 Main)
 (a) $\frac{12}{5}$ (b) 6 (c) 4 (d) $\frac{6}{25}$
12. A multiple choice examination has 5 questions. Each question has three alternative answers of which exactly one is correct. The probability that a student will get 4 or more correct answers just by guessing is (2013 Main)
 (a) $\frac{17}{3^5}$ (b) $\frac{13}{3^5}$ (c) $\frac{11}{3^5}$ (d) $\frac{10}{3^5}$
13. India plays two matches each with West Indies and Australia. In any match the probabilities of India getting points 0, 1 and 2 are 0.45, 0.05 and 0.50, respectively. Assuming that the outcomes are independent. The probability of India getting at least 7 points, is (1992, 2M)
 (a) 0.8750 (b) 0.0875 (c) 0.0625 (d) 0.0250
14. One hundred identical coins, each with probability p , of showing up heads are tossed once. If $0 < p < 1$ and the probability of heads showing on 50 coins is equal to that of heads showing on 51 coins, then the value of p is (1988, 2M)
 (a) 1/2 (b) 49/101 (c) 50/101 (d) 51/101

Fill in the Blanks

15. If the mean and the variance of a binomial variate X are 2 and 1 respectively, then the probability that X takes a value greater than one is equal to... (1991, 2M)
16. For a biased die the probabilities for the different faces to turn up are given below

Face	1	2	3	4	5	6
Probability	0.1	0.32	0.21	0.15	0.05	0.17

This die is tossed and you are told that either face 1 or face 2 has turned up. Then, the probability that it is face 1, is... (1981, 2M)

Analytical & Descriptive Questions

17. Numbers are selected at random, one at a time, from the two-digit numbers 00, 01, 02, ..., 99 with replacement. An event E occurs if and only if the product of the two digits of a selected number is 18. If four numbers are selected, find probability that the event E occurs at least 3 times. (1993, 5M)
18. A is a set containing n elements. A subset P of A is chosen at random. The set A is reconstructed by replacing the elements of P . A subset Q of A is again chosen at random. Find the probability that P and Q have no common elements. (1991, 4M)
19. Suppose the probability for A to win a game against B is 0.4. If A has an option of playing either a 'best of 3 games' or a 'best of 5 games' match against B , which option should choose so that the probability of his winning the match is higher? (no game ends in a draw). (1989, 5M)
20. A man takes a step forward with probability 0.4 and backwards with probability 0.6. Find the probability that at the end of eleven steps he is one step away from the starting point. (1987, 3M)

Integer & Numerical Answer Type Questions

21. Two fair dice, each with faces numbered 1, 2, 3, 4, 5 and 6, are rolled together and the sum of the numbers on the faces is observed. This process is repeated till the sum is either a prime number or a perfect square. Suppose the sum turns out to be a perfect square before it turns out to be a prime number. If p is the probability that this perfect square is an odd number, then the value of $14p$ is
22. The probability that a missile hits a target successfully is 0.75. In order to destroy the target completely, at least three successful hits are required. Then the minimum number of missiles that have to be fired so that the probability of completely destroying the target is NOT less than 0.95, is
23. The minimum number of times a fair coin needs to be tossed, so that the probability of getting atleast two heads is atleast 0.96, is (2015 Adv.)

Answers

Topic 1

1. (c) 2. (a) 3. (a) 4. (d)
 5. (a) 6. (c) 7. (a) 8. (a)
 9. (a) 10. (c) 11. (d) 12. (d)
 13. (a) 14. (b) 15. (c) 16. (b)
 17. (d) 18. (b) 19. (b) 20. (c)
 21. $\frac{1}{36}$ 22. $\frac{1}{3} \leq p \leq \frac{1}{2}$ 23. $\frac{3}{16}$ 24. False
 25. $\frac{(3^n - 3 \cdot 2^n + 3) \times {}^6C_3}{6^n}$ 26. 0.62 27. $\frac{1}{91}$
 28. $1 - \frac{10(n+2)}{{}^{n+7}C_5}$ 29. (i) $\frac{1}{132}$ (ii) $\frac{1}{462}$

Topic 2

1. (b) 2. (b) 3. (a) 4. (c)
 5. (a) 6. (c) 7. (c) 8. (a)
 9. (a, b, c) 10. (a, c) 11. $\frac{11}{40}$ 12. $P(A \cap B)$
 13. False 14. 13.9% 16. No 17. (a)
 18. (c)

Topic 3

1. (d) 2. (b) 3. (b) 4. (a)
 5. (c) 6. (d) 7. (a) 8. (a)
 9. (d) 10. (c) 11. (c) 12. (b)
 13. (b) 14. (a) 15. (a) 16. (b)
 17. (a) 18. (c) 19. (b) 20. (b)
 21. (a, b) 22. (a, b) 23. (a, d) 24. (b, c)
 25. (a, d) 26. (a, d) 27. (a, c) 28. (b, c, d)
 29. $\frac{1}{4}$ 30. $\frac{5}{7}$ 31. $\frac{2}{5}$ 32. $\frac{32}{55}$
 33. $\frac{1}{9}$ 35. $\frac{1}{2}$ 36. $2p^2 - p^3$ 38. $\frac{193}{792}$

39. (i) A, B and C are pairwise independent 40. $\frac{1}{5}$
 41. $\frac{1}{3}$ or $\frac{1}{2}$ 43. 0.6976 44. $\frac{1}{1260}$ 45. 0.50
 46. (6) 47. (b) 48. (c)

Topic 4

1. (d) 2. (b) 3. (c) 4. (c)
 5. (a, c) 6. (b, d) 7. (d) 8. (a, b)
 9. (c, d) 10. (b) 11. (d) 12. (a)
 13. (b)' 14. (d) 15. (b) 16. (a)
 17. (b) 18. $\frac{1}{7}$
 19. $\frac{{}^{12}C_2 \cdot {}^6C_4}{{}^{18}C_6} \cdot \frac{{}^{10}C_1 \cdot {}^2C_1}{{}^{12}C_2} + \frac{{}^{12}C_1 \cdot {}^6C_5}{{}^{18}C_6} \cdot \frac{{}^{11}C_1 \cdot {}^1C_1}{{}^{12}C_2}$ 20. $\frac{9m}{8N+m}$
 21. $\frac{m}{m+n}$ 22. $\frac{4}{35}$
 23. $\alpha = \frac{p}{1-(1-p)^3}, \beta = \frac{p(1-p)}{1-(1-p)^3}, \gamma = \frac{p-2p^2+p^3}{1-(1-p)^3}$
 24. (i) $\frac{1}{2}$ (ii) $\frac{8}{15}$ 25. $\frac{24}{29}$ 26. $\frac{23}{30}$ 27. $\frac{99}{1900}$

Topic 5

1. (b) 2. (11) 3. (c) 4. (c)
 5. (d) 6. (c) 7. (d) 8. (c)
 9. (c) 10. (a) 11. (a) 12. (c)
 13. (b) 14. (d) 15. $\frac{11}{16}$ 16. $\frac{5}{21}$
 17. $\frac{97}{25^4}$ 18. $\left(\frac{3}{4}\right)^n$ 19. Best of 3 games
 20. ${}^{11}C_6(0.24)^5$ 21. (8) 22. (6) 23. (8)

Hints & Solutions

Topic 1 Classical Probability

1. It is given that a person wins ₹15 for throwing a doublet (1, 1) (2, 2), (3, 3), (4, 4), (5, 5), (6, 6) and win ₹12 when the throw results in sum of 9, i.e., when (3, 6), (4, 5), (5, 4), (6, 3) occurs.
 Also, losses ₹ 6 for throwing any other outcome, i.e., when any of the rest $36 - 6 - 4 = 26$ outcomes occurs.
 Now, the expected gain/loss
 $= 15 \times P(\text{getting a doublet}) + 12 \times P(\text{getting sum 9}) - 6 \times P(\text{getting any of rest 26 outcome})$
 $= \left(15 \times \frac{6}{36}\right) + \left(12 \times \frac{4}{36}\right) - \left(6 \times \frac{26}{36}\right)$

$$= \frac{5}{2} + \frac{4}{3} - \frac{26}{6} = \frac{15 + 8 - 26}{6}$$

$$= \frac{23 - 26}{6} = -\frac{3}{6} = -\frac{1}{2}, \text{ means loss of } ₹ \frac{1}{2}$$

2. Since, the experiment should be end in the fifth throw of the die, so total number of outcomes are 6^5 .
 Now, as the last two throws should be result in two fours
 (i) (ii) (iii) (iv) (v)
 So, the third throw can be 1, 2, 3, 5 or 6 (not 4). Also, throw number (i) and (ii) can not take two fours in succession, therefore number of possibilities for throw (i) and (ii) $= 6^2 - 1 = 35$

[∵ when a pair of dice is thrown then (4, 4) occur only once].

114 Probability

Hence, the required probability = $\frac{5 \times 35}{6^5} = \frac{175}{6^5}$

3. Since, there is a regular hexagon, then the number of ways of choosing three vertices is 6C_3 . And, there is only two ways i.e. choosing vertices of a regular hexagon alternate, here A_1, A_3, A_5 or A_2, A_4, A_6 will result in an equilateral triangle.

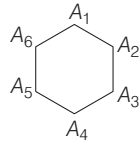

\therefore Required probability
 $= \frac{2}{{}^6C_3} = \frac{2}{6!} = \frac{2 \times 3 \times 2 \times 3 \times 2}{6 \times 5 \times 4 \times 3 \times 2 \times 1} = \frac{1}{3!3!}$

4. Number of subset of $S = 2^{20}$
 Sum of elements in S is $1 + 2 + \dots + 20 = \frac{20(21)}{2} = 210$
 $\left[\because 1 + 2 + \dots + n = \frac{n(n+1)}{2} \right]$

Clearly, the sum of elements of a subset would be 203, if we consider it as follows

$S - \{7\}, S - \{1, 6\}, S - \{2, 5\}, S - \{3, 4\}$
 $S - \{1, 2, 4\}$

\therefore Number of favourable cases = 5
 Hence, required probability = $\frac{5}{2^{20}}$

5. Total number of ways of selecting 2 different numbers from $\{0, 1, 2, \dots, 10\} = {}^{11}C_2 = 55$

Let two numbers selected be x and y .

Then, $x + y = 4m$... (i)
 and $x - y = 4n$... (ii)

$\Rightarrow 2x = 4(m+n)$ and $2y = 4(m-n)$
 $\Rightarrow x = 2(m+n)$ and $y = 2(m-n)$

$\therefore x$ and y both are even numbers.

x	y
0	4, 8
2	6, 10
4	0, 8
6	2, 10
8	0, 4
10	2, 6

\therefore Required probability = $\frac{6}{55}$

6. Sample space $\rightarrow {}^{12}C_2$

Number of possibilities for z is even.

$z = 0 \Rightarrow {}^{11}C_1; z = 2 \Rightarrow {}^9C_1$
 $z = 4 \Rightarrow {}^7C_1; z = 6 \Rightarrow {}^5C_1$
 $z = 8 \Rightarrow {}^3C_1; z = 10 \Rightarrow {}^1C_1$

Total = 36

\therefore Probability = $\frac{36}{66} = \frac{6}{11}$

7. We have mentioned that boxes are different and one particular box has 3 balls.

Then, number of ways = $\frac{{}^{12}C_3 \times 2^9}{3^{12}} = \frac{55}{3} \left(\frac{2}{3}\right)^{11}$

8. Total number of ways to arrange 3 boys and 2 girls are 5!

According to given condition, following cases may arise.

B	G	G	B	B
G	G	B	B	B
G	B	G	B	B
G	B	B	G	B
B	G	B	G	B

So, number of favourable ways = $5 \times 3! \times 2! = 60$

\therefore Required probability = $\frac{60}{120} = \frac{1}{2}$

9. **PLAN** As one of the dice shows a number appearing on one of P_1, P_2 and P_3 .

Thus, three cases arise.

- (i) All show same number.
- (ii) Number appearing on D_4 appears on any one of D_1, D_2 and D_3 .
- (iii) Number appearing on D_4 appears on any two of D_1, D_2 and D_3 .

Sample space = $6 \times 6 \times 6 \times 6 = 6^4$ favourable events
 = Case I or Case II or Case III

Case I First we should select one number for D_4 which appears on all i.e. ${}^6C_1 \times 1$.

Case II For D_4 there are 6C_1 ways. Now, it appears on any one of D_1, D_2 and D_3 i.e. ${}^3C_1 \times 1$.

For other two there are 5×5 ways.

$\Rightarrow {}^6C_1 \times {}^3C_1 \times 1 \times 5 \times 5$

Case III For D_4 there are 6C_1 ways now it appears on any two of D_1, D_2 and D_3

$\Rightarrow {}^3C_2 \times 1^2$

For other one there are 5 ways.

$\Rightarrow {}^6C_1 \times {}^3C_2 \times 1^2 \times 5$

Thus, probability = $\frac{{}^6C_1 + {}^6C_1 \times {}^3C_1 \times 5^2 + {}^6C_1 \times {}^3C_2 \times 5}{6^4}$
 $= \frac{6(1 + 75 + 15)}{6^4}$
 $= \frac{91}{216}$

10. **Sample space** A dice is thrown thrice, $n(s) = 6 \times 6 \times 6$.

Favorable events $\omega^{r_1} + \omega^{r_2} + \omega^{r_3} = 0$

i.e. (r_1, r_2, r_3) are ordered 3 triples which can take values,

$\left. \begin{matrix} (1, 2, 3), (1, 5, 3), (4, 2, 3), (4, 5, 3) \\ (1, 2, 6), (1, 5, 6), (4, 2, 6), (4, 5, 6) \end{matrix} \right\}$ i.e. 8 ordered pairs

and each can be arranged in $3!$ ways = 6

$\therefore n(E) = 8 \times 6 \Rightarrow P(E) = \frac{8 \times 6}{6 \times 6 \times 6} = \frac{2}{9}$

11. Since, three distinct numbers are to be selected from first 100 natural numbers.

$$\Rightarrow n(S) = {}^{100}C_3$$

$E_{(\text{favourable events})}$ = All three of them are divisible by both 2 and 3.

\Rightarrow Divisible by 6 i.e. {6, 12, 18, ..., 96}

Thus, out of 16 we have to select 3.

$$\therefore n(E) = {}^{16}C_3$$

$$\therefore \text{Required probability} = \frac{{}^{16}C_3}{{}^{100}C_3} = \frac{4}{1155}$$

12. Here, two numbers are selected from {1, 2, 3, 4, 5, 6}

$\Rightarrow n(S) = 6 \times 5$ {as one by one without replacement}

Favourable events = the minimum of the two numbers is less than 4. $n(E) = 6 \times 4$ {as for the minimum of the two is less than 4 we can select one from (1, 2, 3, 4) and other from (1, 2, 3, 4, 5, 6)}

$$\therefore \text{Required probability} = \frac{n(E)}{n(S)} = \frac{24}{30} = \frac{4}{5}$$

13. $7^1 = 7, 7^2 = 49, 7^3 = 343, 7^4 = 2401, \dots$

Therefore, for $7^r, r \in N$ the number ends at unit place 7, 9, 3, 1, 7, ...

$\therefore 7^m + 7^n$ will be divisible by 5 if it end at 5 or 0.

But it cannot end at 5.

Also for end at 0.

For this m and n should be as follows

	m	n
1	$4r$	$4r - 2$
2	$4r - 1$	$4r - 3$
3	$4r - 2$	$4r$
4	$4r - 3$	$4r - 1$

For any given value of m , there will be 25 values of n .

Hence, the probability of the required event is

$$\frac{100 \times 25}{100 \times 100} = \frac{1}{4}$$

NOTE Power of prime numbers have cyclic numbers in their unit place.

14. The number of ways of placing 3 black balls without any restriction is ${}^{10}C_3$. Since, we have total 10 places of putting 10 balls in a row. Now, the number of ways in which no two black balls put together is equal to the number of ways of choosing 3 places marked '—' out of eight places.

—W—W—W—W—W—W—

This can be done in 8C_3 ways.

$$\therefore \text{Required probability} = \frac{{}^8C_3}{{}^{10}C_3} = \frac{8 \times 7 \times 6}{10 \times 9 \times 8} = \frac{7}{15}$$

15. Three vertices out of 6 can be chosen in 6C_3 ways.

So, total ways = ${}^6C_3 = 20$

Only two equilateral triangles can be formed $\triangle AEC$ and $\triangle BFD$.

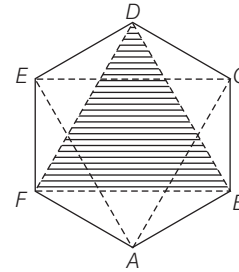

\therefore Favourable ways = 2

$$\text{So, required probability} = \frac{2}{20} = \frac{1}{10}$$

16. Since, three dice are rolled.

\therefore Total number of cases $S = 6 \times 6 \times 6 = 216$

and the same number appear on each of them = ${}^6C_1 = 6$

$$\therefore \text{Required probability} = \frac{6}{216} = \frac{1}{36}$$

17. Since, there are 15 possible cases for selecting a coupon and seven coupons are selected, the total number of cases of selecting seven coupons = 15^7

It is given that the maximum number on the selected coupon is 9, therefore the selection is to be made from the coupons numbered 1 to 9. This can be made in 9^7 ways. Out of these 9^7 cases, 8^7 does not contain the number 9.

Thus, the favourable number of cases = $9^7 - 8^7$.

$$\therefore \text{Required probability} = \frac{9^7 - 8^7}{15^7}$$

18. The number of all possible determinants of the form

$$\begin{vmatrix} a & b \\ c & d \end{vmatrix} = 2^4 = 16$$

Out of which only 10 determinants given by

$$\begin{vmatrix} 1 & 1 \\ 1 & 1 \end{vmatrix}, \begin{vmatrix} 0 & 0 \\ 0 & 0 \end{vmatrix}, \begin{vmatrix} 1 & 1 \\ 0 & 0 \end{vmatrix}, \begin{vmatrix} 0 & 0 \\ 1 & 1 \end{vmatrix}, \begin{vmatrix} 0 & 1 \\ 0 & 1 \end{vmatrix}, \begin{vmatrix} 1 & 0 \\ 1 & 0 \end{vmatrix}, \begin{vmatrix} 1 & 0 \\ 0 & 0 \end{vmatrix},$$

$$\begin{vmatrix} 0 & 1 \\ 0 & 0 \end{vmatrix}, \begin{vmatrix} 0 & 0 \\ 1 & 0 \end{vmatrix}$$

Vanish and remaining six determinants have non-zero values. Hence, the required probability = $\frac{6}{16} = \frac{3}{8}$

Statement I is true.

Statement II is also true as the homogeneous equations have always a solution and Statement II is not the correct explanation of Statement I.

19. **PLAN** Probability = $\frac{\text{Number of favourable outcomes}}{\text{Number of total outcomes}}$

As, $x_1 + x_2 + x_3$ is odd.

So, all may be odd or one of them is odd and other two are even.

116 Probability

$$\begin{aligned} &\therefore \text{Required probability} \\ &= \frac{{}^2C_1 \times {}^3C_1 \times {}^4C_1 + {}^1C_1 \times {}^2C_1 \times {}^4C_1 + {}^2C_1 \times {}^2C_1 \times {}^3C_1 + {}^1C_1 \times {}^3C_1 \times {}^3C_1}{{}^3C_1 \times {}^5C_1 \times {}^7C_1} \\ &= \frac{24 + 8 + 12 + 9}{105} \\ &= \frac{53}{105} \end{aligned}$$

20. Since, x_1, x_2, x_3 are in AP.

$$\therefore x_1 + x_3 = 2x_2$$

So, $x_1 + x_3$ should be even number.

Either both x_1 and x_3 are odd or both are even.

$$\begin{aligned} \therefore \text{Required probability} &= \frac{{}^2C_1 \times {}^4C_1 + {}^1C_1 \times {}^3C_1}{{}^3C_1 \times {}^5C_1 \times {}^7C_1} \\ &= \frac{11}{105} \end{aligned}$$

21. According to given condition,

$$P(\text{yellow at the first toss}) = \frac{3}{6} = \frac{1}{2}$$

$$P(\text{red at the second toss}) = \frac{2}{6} = \frac{1}{3}$$

$$\text{and } P(\text{blue at the third toss}) = \frac{1}{6}$$

Therefore, the probability of the required event

$$= \frac{1}{2} \times \frac{1}{3} \times \frac{1}{6} = \frac{1}{36}$$

22. Since, $\frac{1+3p}{3}$, $\frac{1-p}{4}$ and $\frac{1-2p}{2}$ are the probability of mutually exclusive events.

$$\begin{aligned} \therefore \frac{1+3p}{3} + \frac{1-p}{4} + \frac{1-2p}{2} &\leq 1 \\ \Rightarrow 4 + 12p + 3 - 3p + 6 - 12p &\leq 12 \\ \Rightarrow 13 - 3p &\leq 12 \\ \Rightarrow p &\geq \frac{1}{3} \quad \dots(i) \end{aligned}$$

$$\begin{aligned} \text{and } 0 \leq \frac{1+3p}{3} \leq 1, 0 \leq \frac{1-p}{4} \leq 1, 0 \leq \frac{1-2p}{2} \leq 1 \\ \Rightarrow 0 \leq 1+3p \leq 3, 0 \leq 1-p \leq 4, 0 \leq 1-2p \leq 2 \\ \Rightarrow -\frac{1}{3} \leq p \leq \frac{2}{3}, 1 \geq p \geq -3, \frac{1}{2} \geq p \geq -\frac{1}{2} \quad \dots(ii) \end{aligned}$$

From Eqs. (i) and (ii), $1/3 \leq p \leq 1/2$

23. Since, determinant is of order 2×2 and each element is 0 or 1 only.

$$\therefore n(S) = 2^4 = 16$$

and the determinant is positive are

$$\begin{vmatrix} 1 & 0 \\ 0 & 1 \end{vmatrix}, \begin{vmatrix} 1 & 1 \\ 0 & 1 \end{vmatrix}, \begin{vmatrix} 1 & 0 \\ 1 & 1 \end{vmatrix}$$

$$\therefore n(E) = 3$$

$$\text{Thus, the required probability} = \frac{3}{16}$$

24. Total number of ways to arrange 'ASSASSIN' is $\frac{8!}{4! \cdot 2!}$.

First we fix the position $\otimes A \otimes A \otimes I \otimes N \otimes$.

Number of ways in which no two S's occur together

$$= \frac{4!}{2!} \times {}^5C_4$$

$$\therefore \text{Required probability} = \frac{4! \times 5 \times 4! \times 2!}{2! \times 8!} = \frac{1}{14}$$

Hence, it is a false statement.

25. Let us define an onto function F from $A : [r_1, r_2, \dots, r_n]$ to $B : [1, 2, 3]$, where r_1, r_2, \dots, r_n are the readings of n throws and 1, 2, 3 are the numbers that appear in the n throws.

Number of such functions, $M = N - [n(1) - n(2) + n(3)]$

where, N = total number of functions

and $n(t)$ = number of function having exactly t elements in the range.

$$\text{Now, } N = 3^n, n(1) = 3 \cdot 2^n, n(2) = 3, n(3) = 0$$

$$\Rightarrow M = 3^n - 3 \cdot 2^n + 3$$

Hence, the total number of favourable cases

$$= (3^n - 3 \cdot 2^n + 3) \cdot {}^6C_3$$

$$\therefore \text{Required probability} = \frac{(3^n - 3 \cdot 2^n + 3) \times {}^6C_3}{6^n}$$

26. The required probability = $1 -$ (probability of the event that the roots of $x^2 + px + q = 0$ are non-real).

The roots of $x^2 + px + q = 0$ will be non-real if and only if $p^2 - 4q < 0$, i.e. if $p^2 < 4q$

The possible values of p and q can be possible according to the following table.

Value of q	Value of p	Number of pairs of p, q
1	1	1
2	1, 2	2
3	1, 2, 3	3
4	1, 2, 3	3
5	1, 2, 3, 4	4
6	1, 2, 3, 4	4
7	1, 2, 3, 4, 5	5
8	1, 2, 3, 4, 5	5
9	1, 2, 3, 4, 5	5
10	1, 2, 3, 4, 5, 6	6

Therefore, the number of possible pairs = 38

Also, the total number of possible pairs is $10 \times 10 = 100$

$$\therefore \text{The required probability} = 1 - \frac{38}{100} = 1 - 0.38 = 0.62$$

27. We have 14 seats in two vans and there are 9 boys and 3 girls. The number of ways of arranging 12 people on 14 seats without restriction is

$${}^{14}P_{12} = \frac{14!}{2!} = 7(13!)$$

Now, the number of ways of choosing back seats is 2.
and the number of ways of arranging 3 girls on adjacent seats is $2(3!)$ and the number of ways of arranging 9 boys on the remaining 11 seats is ${}^{11}P_9$ ways.

Therefore, the required number of ways

$$= 2 \cdot (2 \cdot 3!) \cdot {}^{11}P_9 = \frac{4 \cdot 3! \cdot 11!}{2!} = 12!$$

Hence, the probability of the required event

$$= \frac{12!}{7 \cdot 13!} = \frac{1}{91}$$

28. There are $(n + 7)$ coins in the box out of which five coins can be taken out in ${}^{n+7}C_5$ ways.

The total value of 5 coins can be equal to or more than one rupee and fifty paise in the following ways.

- (i) When one 50 paise coin and four 25 paise coins are chosen.
- (ii) When two 50 paise coins and three 25 paise coins are chosen.
- (iii) When two 50 paise coins, 2 twenty five paise coins and one from n coins of ten and five paise.

\therefore The total number of ways of selecting five coins so that the total value of the coins is not less than one rupee and fifty paise is

$$({}^2C_1 \cdot {}^5C_5 \cdot {}^n C_0) + ({}^2C_2 \cdot {}^5C_3 \cdot {}^n C_0) + ({}^2C_2 \cdot {}^5C_2 \cdot {}^n C_1)$$

$$= 10 + 10 + 10n = 10(n + 2)$$

So, the number of ways of selecting five coins, so that the total value of the coins is less than one rupee and fifty paise is ${}^{n+7}C_5 - 10(n + 2)$

$$\therefore \text{Required probability} = \frac{{}^{n+7}C_5 - 10(n + 2)}{{}^{n+7}C_5}$$

$$= 1 - \frac{10(n + 2)}{{}^{n+7}C_5}$$

29. (i) The total number of arrangements of six boys and six girls = 12!

$$\therefore \text{Required probability} = \frac{6! \times 7!}{(12)!} = \frac{1}{132}$$

[since, we consider six girls at one person]

(ii) Required probability = $\frac{2 \times 6! \times 6!}{(12)!} = \frac{1}{462}$

Topic 2 Addition and Subtraction Law of Probability

1. As, we know that

$$P(A \cap B) = P(A) + P(B) - P(A \cup B)$$

$$\Rightarrow P(A \cap B) = 0.6 + 0.4 - 0.8 \Rightarrow P(A \cap B) = 0.2$$

and, as

$$P(A \cup B \cup C) = P(A) + P(B) + P(C)$$

$$- P(A \cap B) - P(B \cap C) - P(C \cap A) + P(A \cap B \cap C)$$

$$\Rightarrow \alpha = 0.6 + 0.4 + 0.5 - 0.2 - \beta - 0.3 + 0.2$$

$$\Rightarrow \alpha = 1.2 - \beta$$

$$\therefore 0.85 \leq \alpha \leq 0.95 \Rightarrow 0.85 \leq 1.2 - \beta \leq 0.95$$

$$\Rightarrow 0.25 \leq \beta \leq 0.35$$

2. We have, P (exactly one of A or B occurs)

$$= P(A \cup B) - P(A \cap B)$$

$$= P(A) + P(B) - 2P(A \cap B)$$

According to the question,

$$P(A) + P(B) - 2P(A \cap B) = \frac{1}{4} \quad \dots(i)$$

$$P(B) + P(C) - 2P(B \cap C) = \frac{1}{4} \quad \dots(ii)$$

and $P(C) + P(A) - 2P(C \cap A) = \frac{1}{4} \quad \dots(iii)$

On adding Eqs. (i), (ii) and (iii), we get

$$2 [P(A) + P(B) + P(C) - P(A \cap B) - P(B \cap C) - P(C \cap A)] = \frac{3}{4}$$

$$\Rightarrow P(A) + P(B) + P(C) - P(A \cap B) - P(B \cap C) - P(C \cap A) = \frac{3}{8}$$

$\therefore P$ (atleast one event occurs)

$$= P(A \cup B \cup C)$$

$$= P(A) + P(B) + P(C) - P(A \cap B) - P(B \cap C) - P(C \cap A) + P(A \cap B \cap C)$$

$$= \frac{3}{8} + \frac{1}{16} = \frac{7}{16} \quad \left[\because P(A \cap B \cap C) = \frac{1}{16} \right]$$

3. Given, $P(B) = \frac{3}{4}$, $P(A \cap B \cap \bar{C}) = \frac{1}{3}$

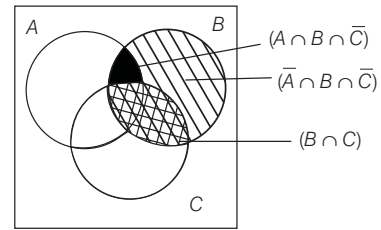

and $P(\bar{A} \cap B \cap \bar{C}) = \frac{1}{3}$

which can be shown in Venn diagram.

$$\therefore P(B \cap C) = P(B) - \{P(A \cap B \cap \bar{C}) + P(\bar{A} \cap B \cap \bar{C})\}$$

$$= \frac{3}{4} - \left(\frac{1}{3} + \frac{1}{3} \right) = \frac{3}{4} - \frac{2}{3} = \frac{1}{12}$$

4. It is given that, $P(E) \leq P(F) \Rightarrow E \subseteq F \quad \dots(i)$

and $P(E \cap F) > 0 \Rightarrow E \subset F \quad \dots(ii)$

(a) occurrence of $E \Rightarrow$ occurrence of F [from Eq. (i)]

(b) occurrence of $F \Rightarrow$ occurrence of E [from Eq. (ii)]

(c) non-occurrence of $E \Rightarrow$ occurrence of F

Hence, option (c) is not correct. [from Eq. (i)]

5. We know that,

$$P \text{ (exactly one of } A \text{ or } B \text{ occurs)}$$

$$= P(A) + P(B) - 2P(A \cap B)$$

$$\therefore P(A) + P(B) - 2P(A \cap B) = p \quad \dots(i)$$

Similarly, $P(B) + P(C) - 2P(B \cap C) = p \quad \dots(ii)$

and $P(C) + P(A) - 2P(C \cap A) = p \quad \dots(iii)$

118 Probability

On adding Eqs. (i), (ii) and (iii), we get

$$2 [P(A) + P(B) + P(C) - P(A \cap B) - P(B \cap C) - P(C \cap A)] = 3p$$

$$\Rightarrow P(A) + P(B) + P(C) - P(A \cap B) - P(B \cap C) - P(C \cap A) = \frac{3p}{2} \quad \dots(v)$$

It also given that, $P(A \cap B \cap C) = p^2 \quad \dots(v)$

$$\therefore P(\text{at least one of the events } A, B, \text{ and } C \text{ occurs})$$

$$= P(A) + P(B) + P(C) - P(A \cap B) - P(B \cap C) - P(C \cap A) + P(A \cap B \cap C)$$

$$= \frac{3p}{2} + p^2 \quad [\text{from Eqs. (iv) and (v)}]$$

$$= \frac{3p + 2p^2}{2}$$

6. Since, $P(A \cap B) = P(A) \cdot P(B)$

It means A and B are independent events, so A' and B' are also independent.

$$\therefore P(A \cup B)' = P(A' \cap B') = P(A') \cdot P(B')$$

Alternate Solution

$$P(A \cup B)' = 1 - P(A \cup B) = 1 - \{P(A) + P(B) - P(A \cap B)\}$$

$$= \{1 - P(A)\} \{1 - P(B)\} = P(A') \cdot P(B')$$

7. Given, $P(A \cup B) = 0.6$, $P(A \cap B) = 0.2$

$$\therefore P(\bar{A}) + P(\bar{B}) = [1 - P(A)] + [1 - P(B)]$$

$$= 2 - [P(A) + P(B)]$$

$$= 2 - [P(A \cup B) + P(A \cap B)] = 2 - [0.6 + 0.2] = 1.2$$

8. Given, $P(A) = 0.25$, $P(B) = 0.50$, $P(A \cap B) = 0.14$

$$\therefore P(A \cup B) = P(A) + P(B) - P(A \cap B)$$

$$= 0.25 + 0.50 - 0.14 = 0.61$$

$$\text{Now, } P(\overline{A \cup B}) = 1 - P(A \cup B) = 1 - 0.61 = 0.39$$

9. We know that,

$$P(A \cap B) = P(A) + P(B) - P(A \cup B)$$

Also, $P(A \cup B) \leq 1$

$$\therefore P(A \cap B)_{\min.}, \text{ when } P(A \cup B)_{\max} = 1$$

$$\Rightarrow P(A \cap B) \geq P(A) + P(B) - 1$$

\therefore Option (a) is true.

Again, $P(A \cup B) \geq 0$

$$\therefore P(A \cap B)_{\max}, \text{ when } P(A \cup B)_{\min.} = 0$$

$$\Rightarrow P(A \cap B) \leq P(A) + P(B)$$

\therefore Option (b) is true.

Also, $P(A \cap B) = P(A) + P(B) - P(A \cup B)$, Thus, (c) is also correct.

Hence, (a), (b), (c) are correct options.

10. $P(\text{exactly one of } M, N \text{ occurs})$

$$= P\{(M \cap \bar{N}) \cup (\bar{M} \cap N)\} = P(M \cap \bar{N}) + P(\bar{M} \cap N)$$

$$= P(M) - P(M \cap N) + P(N) - P(M \cap N)$$

$$= P(M) + P(N) - 2P(M \cap N)$$

Also, $P(\text{exactly one of them occurs})$

$$= \{1 - P(\bar{M} \cap \bar{N})\} \{1 - P(\bar{M} \cup \bar{N})\}$$

$$= P(\bar{M} \cup \bar{N}) - P(\bar{M} \cap \bar{N}) = P(\bar{M}) + P(\bar{N}) - 2P(\bar{M} \cap \bar{N})$$

Hence, (a) and (c) are correct answers.

11. Let E_1 be the event getting minimum number 3 and E_2 be the event getting maximum number 7.

$$\text{Then, } P(E_1) = P(\text{getting one number 3 and other two from numbers 4 to 10})$$

$$= \frac{{}^1C_1 \times {}^7C_2}{{}^{10}C_3} = \frac{7}{40}$$

$$P(E_2) = P(\text{getting one number 7 and other two from numbers 1 to 6})$$

$$= \frac{{}^1C_1 \times {}^6C_2}{{}^{10}C_3} = \frac{1}{8}$$

and $P(E_1 \cap E_2) = P(\text{getting one number 3, second number 7 and third from 4 to 6})$

$$= \frac{{}^1C_1 \times {}^1C_1 \times {}^3C_1}{{}^{10}C_3} = \frac{1}{40}$$

$$\therefore P(E_1 \cup E_2) = P(E_1) + P(E_2) - P(E_1 \cap E_2)$$

$$= \frac{7}{40} + \frac{1}{8} - \frac{1}{40} = \frac{11}{40}$$

12. $P(A \cup B) = P(A) + P(B) - P(A \cap B)$

$$\text{If } P(A \cup B) = P(A \cap B),$$

then $P(A)$ and $P(B)$ are equals.

Since, $P(A \cup B) = P(A \cap B) \Rightarrow A$ and B are equals sets

Thus, $P(A)$ and $P(B)$ is equal to $P(A \cap B)$.

13. Given, $P(A \text{ fails in examination}) = 0.2$

and $P(B \text{ fails in examination}) = 0.3$

$$P(A \cap B) = P(A)P(B) = (0.2)(0.3)$$

$$\therefore P(A \cup B) = P(A) + P(B) - P(A \cap B)$$

$$= 0.2 + 0.3 - 0.06 = 0.44$$

Hence, it is a false statement.

14. Let $P(A)$ and $P(B)$ denote respectively the percentage of city population that reads newspapers A and B .

Then,

$$P(A) = \frac{25}{100} = \frac{1}{4}, P(B) = \frac{20}{100} = \frac{1}{5},$$

$$P(A \cap B) = \frac{8}{100} = \frac{2}{25},$$

$$P(A \cap B) = P(A) - P(A \cap B) = \frac{1}{4} - \frac{2}{25} = \frac{17}{100},$$

$$P(\bar{A} \cap B) = P(B) - P(A \cap B) = \frac{1}{5} - \frac{2}{25} = \frac{3}{25}$$

Let $P(C)$ be the probability that the population who reads advertisements.

$$\therefore P(C) = 30\% \text{ of } P(A \cap \bar{B}) + 40\% \text{ of } P(\bar{A} \cap B) + 50\% \text{ of } P(A \cap B)$$

[since, $A \cap \bar{B}$, $\bar{A} \cap B$ and $A \cap B$ are all mutually exclusive]

$$\Rightarrow P(C) = \frac{3}{10} \times \frac{17}{100} + \frac{2}{5} \times \frac{3}{25} + \frac{1}{2} \times \frac{2}{25} = \frac{139}{1000} = 13.9\%$$

15. We know that,

$$P(A) + P(B) + P(C) - P(A \cap B) - P(B \cap C) - P(C \cap A) + P(A \cap B \cap C) = P(A \cup B \cup C)$$

$$\Rightarrow 0.3 + 0.4 + 0.8 - \{0.08 + 0.28 + P(BC)\} + 0.09 = P(A \cup B \cup C)$$

$$\Rightarrow 1.23 - P(BC) = P(A \cup B \cup C)$$

where, $0.75 \leq P(A \cup B \cup C) \leq 1$

$$\Rightarrow 0.75 \leq 1.23 - P(BC) \leq 1 \Rightarrow -0.48 \leq -P(BC) \leq -0.23$$

$$\Rightarrow 0.23 \leq P(BC) \leq 0.48$$

16. Given, $P(A) = 0.5$ and $P(A \cap B) \leq 0.3$

$$\Rightarrow P(A) + P(B) - P(A \cup B) \leq 0.3$$

$$\Rightarrow P(B) \leq 0.3 + P(A \cup B) - P(A) \leq P(A \cup B) - 0.2$$

$$[\text{since, } P(A \cup B) \leq 1 \Rightarrow P(A \cup B) - 0.2 \leq 0.8]$$

$$\therefore P(B) \leq 0.8$$

$$\Rightarrow P(B) \text{ cannot be } 0.9.$$

17. Here, five students S_1, S_2, S_3, S_4 and S_5 and five seats R_1, R_2, R_3, R_4 and R_5

\therefore Total number of arrangement of sitting five students is $5! = 120$

Here, S_1 gets previously allotted seat R_1

$\therefore S_2, S_3, S_4$ and S_5 not get previously seats.

Total number of way S_2, S_3, S_4 and S_5 not get previously seats is

$$4! \left(1 - \frac{1}{1!} + \frac{1}{2!} - \frac{1}{3!} + \frac{1}{4!} \right) = 24 \left(1 - 1 + \frac{1}{2} - \frac{1}{6} + \frac{1}{24} \right)$$

$$= 24 \left(\frac{12 - 4 + 1}{24} \right) = 9$$

$$\therefore \text{ Required probability} = \frac{9}{120} = \frac{3}{40}$$

18. Here, $n(T_1 \cap T_2 \cap T_3 \cap T_4)$

$$\text{Total} = -n(\overline{T_1} \cup \overline{T_2} \cup \overline{T_3} \cup \overline{T_4})$$

$$\Rightarrow n(T_1 \cap T_2 \cap T_3 \cap T_4) = 5! - [{}^4C_1 4!2! - ({}^3C_1 3!2! + {}^3C_1 3!2!2!) + ({}^2C_1 2!2! + {}^4C_1 2 \cdot 2!) - 2]$$

$$\Rightarrow n(T_1 \cap T_2 \cap T_3 \cap T_4) = 120 - [192 - (36 + 72) + (8 + 16) - 2]$$

$$= 120 - [192 - 108 + 24 - 2] = 14$$

$$\therefore \text{ Required probability} = \frac{14}{120} = \frac{7}{60}$$

Topic 3 Independent and Conditional Probability

1. Let event B is being boy while event G being girl.

According to the question, $P(B) = P(G) = \frac{1}{2}$

Now, required conditional probability that all children are girls given that at least two are girls, is

$$= \frac{\text{All 4 girls}}{(\text{All 4 girls}) + (\text{exactly 3 girls} + 1 \text{ boy}) + (\text{exactly 2 girls} + 2 \text{ boys})}$$

$$= \frac{\left(\frac{1}{2}\right)^4}{\left(\frac{1}{2}\right)^4 + {}^4C_3 \left(\frac{1}{2}\right)^3 \left(\frac{1}{2}\right) + {}^4C_2 \left(\frac{1}{2}\right)^2 \left(\frac{1}{2}\right)^2} = \frac{1}{1 + 4 + 6} = \frac{1}{11}$$

2. **Key Idea** Use $P(\bar{A}) = 1 - P(A)$ and condition of independent events i.e $P(A \cap B) = P(A) \cdot P(B)$

Given that probability of hitting a target independently by four persons are respectively

$$P_1 = \frac{1}{2}, P_2 = \frac{1}{3}, P_3 = \frac{1}{4} \text{ and } P_4 = \frac{1}{8}$$

Then, the probability of not hitting the target is

$$= \left(1 - \frac{1}{2}\right) \left(1 - \frac{1}{3}\right) \left(1 - \frac{1}{4}\right) \left(1 - \frac{1}{8}\right)$$

[\because events are independent]

$$= \frac{1}{2} \times \frac{2}{3} \times \frac{3}{4} \times \frac{7}{8} = \frac{7}{32}$$

Therefore, the required probability of hitting the target = $1 - (\text{Probability of not hitting the target})$

$$= 1 - \frac{7}{32} = \frac{25}{32}$$

3. We know that, $P(A/B) = \frac{P(A \cap B)}{P(B)}$

[by the definition of conditional probability]

$$\therefore A \subset B$$

$$\Rightarrow A \cap B = A$$

$$\therefore P(A/B) = \frac{P(A)}{P(B)} \quad \dots(i)$$

As we know that, $0 \leq P(B) \leq 1$

$$\therefore 1 \leq \frac{1}{P(B)} < \infty \Rightarrow P(A) \leq \frac{P(A)}{P(B)} < \infty$$

$$\Rightarrow \frac{P(A)}{P(B)} \geq P(A) \quad \dots(ii)$$

Now, from Eqs. (i) and (ii), we get

$$P(A/B) \geq P(A)$$

4. In $\{1, 2, 3, \dots, 11\}$ there are 5 even numbers and 6 odd numbers. The sum even is possible only when both are odd or both are even.

Let A be the event that denotes both numbers are even and B be the event that denotes sum of numbers is even.

Then, $n(A) = {}^5C_2$ and $n(B) = {}^5C_2 + {}^6C_2$

Required probability

$$P(A/B) = \frac{P(A \cap B)}{P(B)} = \frac{{}^5C_2 / {}^{11}C_2}{{}^6C_2 + {}^5C_2}$$

$$= \frac{{}^5C_2}{{}^6C_2 + {}^5C_2} = \frac{10}{15 + 10} = \frac{2}{5}$$

5. Clearly, $P(H) = \text{Probability of getting head} = \frac{1}{2}$
and $P(T) = \text{Probability of getting tail} = \frac{1}{2}$

Now, let E_1 be the event of getting a sum 7 or 8, when a pair of dice is rolled.

120 Probability

Then, $E_1 = \{(6, 1), (5, 2), (4, 3), (3, 4), (2, 5), (1, 6), (6, 2), (5, 3), (4, 4), (3, 5), (2, 6)\}$

$\Rightarrow P(E_1) = \text{Probability of getting 7 or 8 when a pair of dice is thrown} = \frac{11}{36}$

Also, let $P(E_2) = \text{Probability of getting 7 or 8 when a card is picked from cards numbered } 1, 2, \dots, 9 = \frac{2}{9}$

\therefore Probability that the noted number is 7 or 8

$$= P((H \cap E_1) \text{ or } (T \cap E_2)) \\ = P(H \cap E_1) + P(T \cap E_2)$$

[$\because (H \cap E_1)$ and $(T \cap E_2)$ are mutually exclusive]

$$= P(H) \cdot P(E_1) + P(T) \cdot P(E_2)$$

[$\because \{H, E_1\}$ and $\{T, E_2\}$ both are sets of independent events]

$$= \frac{1}{2} \times \frac{11}{36} + \frac{1}{2} \times \frac{2}{9} = \frac{19}{72}$$

6. Clearly, $E_1 = \{(4, 1), (4, 2), (4, 3), (4, 4), (4, 5), (4, 6)\}$

$$E_2 = \{(1, 2), (2, 2), (3, 2), (4, 2), (5, 2), (6, 2)\}$$

and $E_3 = \{(1, 2), (1, 4), (1, 6), (2, 1), (2, 3), (2, 5), (3, 2), (3, 4), (3, 6), (4, 1), (4, 3), (4, 5), (5, 2), (5, 4), (5, 6), (6, 1), (6, 3), (6, 5)\}$

$$\Rightarrow P(E_1) = \frac{6}{36} = \frac{1}{6}, P(E_2) = \frac{6}{36} = \frac{1}{6}$$

$$\text{and } P(E_3) = \frac{18}{36} = \frac{1}{2}$$

$$\text{Now, } P(E_1 \cap E_2) = P(\text{getting 4 on die A and 2 on die B}) \\ = \frac{1}{36} = P(E_1) \cdot P(E_2)$$

$$P(E_2 \cap E_3) = P(\text{getting 2 on die B and sum of numbers on both dice is odd})$$

$$= \frac{3}{36} = P(E_2) \cdot P(E_3)$$

$$P(E_1 \cap E_3) = P(\text{getting 4 on die A and sum of numbers on both dice is odd})$$

$$= \frac{3}{36} = P(E_1) \cdot P(E_3)$$

$$\text{and } P(E_1 \cap E_2 \cap E_3) = P(\text{getting 4 on die A, 2 on die B and sum of numbers is odd}) \\ = P(\text{impossible event}) = 0$$

Hence, E_1, E_2 and E_3 are not independent.

7. Given, $P(A \cup B) = \frac{1}{6}, P(A \cap B) = \frac{1}{4}, P(\bar{A}) = \frac{1}{4}$

$$\therefore P(A \cup B) = 1 - P(\overline{A \cup B}) = 1 - \frac{1}{6} = \frac{5}{6}$$

$$\text{and } P(A) = 1 - P(\bar{A}) = 1 - \frac{1}{4} = \frac{3}{4}$$

$$\therefore P(A \cup B) = P(A) + P(B) - P(A \cap B)$$

$$\frac{5}{6} = \frac{3}{4} + P(B) - \frac{1}{4}$$

$$\Rightarrow P(B) = \frac{1}{3} \Rightarrow A \text{ and } B \text{ are not equally likely}$$

$$P(A \cap B) = P(A) \cdot P(B) = \frac{1}{4}$$

So, events are independent.

8. **PLAN** It is simple application of independent event, to solve a certain problem or any type of competition each event is independent of other.

Formula used

$P(A \cap B) = P(A) \cdot P(B)$, when A and B are independent events.

Probability that the problem is solved correctly by atleast one of them = $1 - (\text{problem is not solved by all})$

$\therefore P(\text{problem is solved}) = 1 - P(\text{problem is not solved})$

$$= 1 - P(\bar{A}) \cdot P(\bar{B}) \cdot P(\bar{C}) \cdot P(\bar{D})$$

$$= 1 - \left(\frac{1}{2} \cdot \frac{1}{4} \cdot \frac{3}{4} \cdot \frac{7}{8}\right) = 1 - \frac{21}{256} = \frac{235}{256}$$

9. Since, $P(A) = \frac{2}{5}$

For independent events,

$$P(A \cap B) = P(A)P(B)$$

$$\Rightarrow P(A \cap B) \leq \frac{2}{5} \Rightarrow P(A \cap B) = \frac{1}{10}, \frac{2}{10}, \frac{3}{10}, \frac{4}{10}$$

[maximum 4 outcomes may be in $A \cap B$]

$$(i) \text{ Now, } P(A \cap B) = \frac{1}{10}$$

$$\Rightarrow P(A) \cdot P(B) = \frac{1}{10}$$

$$\Rightarrow P(B) = \frac{1}{10} \times \frac{5}{2} = \frac{1}{4}, \text{ not possible}$$

$$(ii) \text{ Now, } P(A \cap B) = \frac{2}{10} \Rightarrow \frac{2}{5} \times P(B) = \frac{2}{10}$$

$$\Rightarrow P(B) = \frac{5}{10}, \text{ outcomes of } B = 5$$

$$(iii) \text{ Now, } P(A \cap B) = \frac{3}{10}$$

$$\Rightarrow P(A)P(B) = \frac{3}{10} \Rightarrow \frac{2}{5} \times P(B) = \frac{3}{10}$$

$$P(B) = \frac{3}{4}, \text{ not possible}$$

$$(iv) \text{ Now, } P(A \cap B) = \frac{4}{10} \Rightarrow P(A) \cdot P(B) = \frac{4}{10}$$

$$\Rightarrow P(B) = 1, \text{ outcomes of } B = 10.$$

$$10. P\left(\frac{E^c \cap F^c}{G}\right) = \frac{P(E^c \cap F^c \cap G)}{P(G)} \\ = \frac{P(G) - P(E \cap G) - P(G \cap F)}{P(G)} \\ = \frac{P(G) [1 - P(E) - P(F)]}{P(G)} \quad [\because P(G) \neq 0] \\ = 1 - P(E) - P(F) = P(E^c) - P(F)$$

11. Let $E = \text{event when each American man is seated adjacent to his wife}$

and $A = \text{event when Indian man is seated adjacent to his wife}$

$$\text{Now, } n(A \cap E) = (4!) \times (2!)^5$$

Even when each American man is seated adjacent to his wife.

$$\text{Again, } n(E) = (5!) \times (2!)^4$$

$$\therefore P\left(\frac{A}{E}\right) = \frac{n(A \cap E)}{n(E)} = \frac{(4!) \times (2!)^5}{(5!) \times (2!)^4} = \frac{2}{5}$$

Alternate Solution

Fixing four American couples and one Indian man in between any two couples; we have 5 different ways in which his wife can be seated, of which 2 cases are favourable.

$$\therefore \text{Required probability} = \frac{2}{5}$$

12. Let E be the event of getting 1 on a die.

$$\Rightarrow P(E) = \frac{1}{6} \quad \text{and} \quad P(\bar{E}) = \frac{5}{6}$$

$\therefore P$ (first time 1 occurs at the even throw)

$$= \{P(\bar{E})P(E)\} + \{P(\bar{E})P(\bar{E})P(\bar{E})P(E)\} + \dots \infty$$

$$= \left(\frac{5}{6}\right)\left(\frac{1}{6}\right) + \left(\frac{5}{6}\right)^3\left(\frac{1}{6}\right) + \left(\frac{5}{6}\right)^5\left(\frac{1}{6}\right) + \dots \infty = \frac{\frac{5}{36}}{1 - \frac{25}{36}} = \frac{5}{11}$$

13. Probability that only two tests are needed = Probability that the first machine tested is faulty \times Probability that the second machine tested is faulty = $\frac{2}{4} \times \frac{1}{3} = \frac{1}{6}$

14. The event that the fifth toss results in a head is independent of the event that the first four tosses result in tails.

\therefore Probability of the required event = $1/2$

15. P (2 white and 1 black) = $P(W_1W_2B_3 \text{ or } W_1B_2W_3 \text{ or } B_1W_2W_3)$
- $$= P(W_1W_2B_3) + P(W_1B_2W_3) + P(B_1W_2W_3)$$
- $$= P(W_1)P(W_2)P(B_3) + P(W_1)P(B_2)P(W_3) + P(B_1)P(W_2)P(W_3)$$
- $$= \frac{3}{4} \cdot \frac{2}{4} \cdot \frac{3}{4} + \frac{3}{4} \cdot \frac{2}{4} \cdot \frac{1}{4} + \frac{1}{4} \cdot \frac{2}{4} \cdot \frac{1}{4} = \frac{1}{32} (9 + 3 + 1) = \frac{13}{32}$$

16. Given, P (India wins) = $1/2$

$$\therefore P$$
 (India losses) = $1/2$

Out of 5 matches India's second win occurs at third test.
 \Rightarrow India wins third test and simultaneously it has won one match from first two and lost the other.

\therefore Required probability = $P(LWW) + P(WLW)$

$$= \left(\frac{1}{2}\right)^3 + \left(\frac{1}{2}\right)^3 = \frac{1}{4}$$

17. Let A = getting not less than 2 and not greater than 5

$$\Rightarrow A = \{2, 3, 4, 5\} \Rightarrow P(A) = \frac{4}{6}$$

But die is rolled four times, therefore the probability in getting four throws

$$= \left(\frac{4}{6}\right)\left(\frac{4}{6}\right)\left(\frac{4}{6}\right)\left(\frac{4}{6}\right) = \frac{16}{81}$$

18. Let A, B and C denote the events of passing the tests I, II and III, respectively.

Evidently A, B and C are independent events.

According to given condition,

$$\frac{1}{2} = P[(A \cap B) \cup (A \cap C)]$$

$$= P(A \cap B) + P(A \cap C) - P(A \cap B \cap C)$$

$$= P(A)P(B) + P(A)P(C) - P(A)P(B)P(C)$$

$$= pq + p \cdot \frac{1}{2} - pq \cdot \frac{1}{2}$$

$$\Rightarrow 1 = 2pq + p - pq \Rightarrow 1 = p(q + 1) \quad \dots(i)$$

The values of option (c) satisfy Eq. (i).

[Infact, Eq. (i) is satisfied for infinite number of values of p and q . If we take any values of q such that $0 \leq q \leq 1$, then, p takes the value $\frac{1}{q+1}$. It is evident that,

$0 < \frac{1}{q+1} \leq 1$ i.e. $0 < p \leq 1$. But we have to choose correct answer from given ones.]

19. Since, $P(A/\bar{B}) + P(\bar{A}/\bar{B}) = 1$

$$\therefore P(\bar{A}/\bar{B}) = 1 - P(A/\bar{B})$$

20. Given that, $P(A) = 0.4, P(\bar{A}) = 0.6$

P (the event A happens at least once)

$$= 1 - P(\text{none of the event happens})$$

$$= 1 - (0.6)(0.6)(0.6) = 1 - 0.216 = 0.784$$

21. $P(X) = \frac{1}{3}$

$$P\left(\frac{X}{Y}\right) = \frac{P(X \cap Y)}{P(Y)} = \frac{1}{2}$$

$$P\left(\frac{Y}{X}\right) = \frac{P(X \cap Y)}{P(X)} = \frac{2}{5}$$

$$P(X \cap Y) = \frac{2}{15}$$

$$P(Y) = \frac{4}{15}$$

$$P\left(\frac{X'}{Y}\right) = \frac{P(Y) - P(X \cap Y)}{P(Y)} = \frac{\frac{4}{15} - \frac{2}{15}}{\frac{4}{15}} = \frac{1}{2}$$

$$P(X \cup Y) = \frac{1}{3} + \frac{4}{15} - \frac{2}{15} = \frac{7}{15} = \frac{7}{15}$$

22. PLAN

(i) Conditional probability, i.e. $P(A/B) = \frac{P(A \cap B)}{P(B)}$

(ii) $P(A \cup B) = P(A) + P(B) - P(A \cap B)$

(iii) Independent event, then $P(A \cap B) = P(A) \cdot P(B)$

Here, $P(X/Y) = \frac{1}{2}, P\left(\frac{Y}{X}\right) = \frac{1}{3}$

and $P(X \cap Y) = 6$

$$\therefore P\left(\frac{X}{Y}\right) = \frac{P(X \cap Y)}{P(Y)}$$

122 Probability

$$\Rightarrow \frac{1}{2} = \frac{1/6}{P(Y)} \Rightarrow P(Y) = \frac{1}{3} \quad \dots(i)$$

$$P\left(\frac{Y}{X}\right) = \frac{1}{3} \Rightarrow \frac{P(X \cap Y)}{P(X)} = \frac{1}{3}$$

$$\Rightarrow \frac{1}{6} = \frac{1}{3} P(X)$$

$$\therefore P(X) = \frac{1}{2} \quad \dots(ii)$$

$$P(X \cup Y) = P(X) + P(Y) - P(X \cap Y) \\ = \frac{1}{2} + \frac{1}{3} - \frac{1}{6} = \frac{2}{3} \quad \dots(iii)$$

$$P(X \cap Y) = \frac{1}{6} \text{ and } P(X) \cdot P(Y) = \frac{1}{2} \cdot \frac{1}{3} = \frac{1}{6}$$

$$\Rightarrow P(X \cap Y) = P(X) \cdot P(Y)$$

i.e. independent events

$$\therefore P(X^c \cap Y) = P(Y) - P(X \cap Y) \\ = \frac{1}{3} - \frac{1}{6} = \frac{1}{6}$$

23.

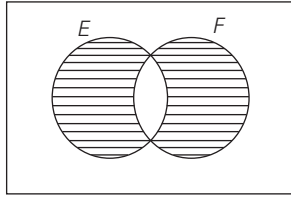

$$P(E \cup F) - P(E \cap F) = \frac{11}{25} \quad \dots(i)$$

[i.e. only E or only F]

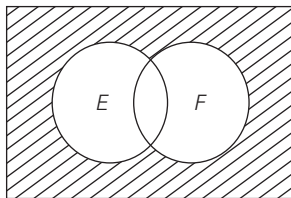

$$\text{Neither of them occurs} = \frac{2}{25}$$

$$\Rightarrow P(\bar{E} \cap \bar{F}) = \frac{2}{25} \quad \dots(ii)$$

$$\text{From Eq. (i), } P(E) + P(F) - 2P(E \cap F) = \frac{11}{25} \quad \dots(iii)$$

$$\text{From Eq. (ii), } (1 - P(E))(1 - P(F)) = \frac{2}{25}$$

$$\Rightarrow 1 - P(E) - P(F) + P(E) \cdot P(F) = \frac{2}{25} \quad \dots(iv)$$

From Eqs. (iii) and (iv),

$$P(E) + P(F) = \frac{7}{5} \text{ and } P(E) \cdot P(F) = \frac{12}{25}$$

$$\therefore P(E) \cdot \left[\frac{7}{5} - P(E) \right] = \frac{12}{25} \Rightarrow (P(E))^2 - \frac{7}{5} P(E) + \frac{12}{25} = 0$$

$$\Rightarrow \left[P(E) - \frac{3}{5} \right] \left[P(E) - \frac{4}{5} \right] = 0$$

$$\therefore P(E) = \frac{3}{5} \text{ or } \frac{4}{5} \Rightarrow P(F) = \frac{4}{5} \text{ or } \frac{3}{5}$$

24. Let A, B and C respectively denote the events that the student passes in Maths, Physics and Chemistry.

It is given,

$$P(A) = m, P(B) = p \text{ and } P(C) = c \text{ and}$$

P (passing atleast in one subject)

$$= P(A \cup B \cup C) = 0.75$$

$$\Rightarrow 1 - P(A' \cap B' \cap C') = 0.75$$

$$\therefore [P(A) = 1 - P(\bar{A})]$$

$$\text{and } [P(A \cup B \cup C) = P(A' \cap B' \cap C')]$$

$$\Rightarrow 1 - P(A') \cdot P(B') \cdot P(C') = 0.75$$

\(\therefore\) A, B and C are independent events, therefore A', B and C' are independent events.

$$\Rightarrow 0.75 = 1 - (1 - m)(1 - p)(1 - c)$$

$$\Rightarrow 0.25 = (1 - m)(1 - p)(1 - c) \quad \dots(i)$$

Also, P (passing exactly in two subjects) = 0.4

$$\Rightarrow P(A \cap B \cap \bar{C}) \cup P(A \cap \bar{B} \cap C) \cup P(\bar{A} \cap B \cap C) = 0.4$$

$$\Rightarrow P(A \cap B \cap \bar{C}) + P(A \cap \bar{B} \cap C) + P(\bar{A} \cap B \cap C) = 0.4$$

$$\Rightarrow P(A)P(B)P(\bar{C}) + P(A)P(\bar{B})P(C)$$

$$+ P(\bar{A})P(B)P(C) = 0.4$$

$$\Rightarrow pm(1 - c) + p(1 - m)c + (1 - p)mc = 0.4$$

$$\Rightarrow pm - pmc + pc - pmc + mc - pmc = 0.4 \quad \dots(ii)$$

Again, P (passing atleast in two subjects) = 0.5

$$\Rightarrow P(A \cap B \cap \bar{C}) + P(A \cap \bar{B} \cap C)$$

$$+ P(\bar{A} \cap B \cap C) + P(A \cap B \cap C) = 0.5$$

$$\Rightarrow pm(1 - c) + pc(1 - m) + cm(1 - p) + pcm = 0.5$$

$$\Rightarrow pm - pcm + pc - pcm + cm - pcm + pcm = 0.5$$

$$\Rightarrow (pm + pc + mc) - 2pcm = 0.5 \quad \dots(iii)$$

From Eq. (ii),

$$pm + pc + mc - 3pcm = 0.4 \quad \dots(iv)$$

From Eq. (i),

$$0.25 = 1 - (m + p + c) + (pm + pc + cm) - pcm \quad \dots(v)$$

On solving Eqs. (iii), (iv) and (v), we get

$$p + m + c = 1.35 = 27/20$$

Therefore, option (b) is correct.

Also, from Eqs. (ii) and (iii), we get $pmc = 1/10$

Hence, option (c) is correct.

$$25. (a) P(E/F) + P(\bar{E}/F) = \frac{P(E \cap F)}{P(F)} + \frac{P(\bar{E} \cap F)}{P(F)}$$

$$= \frac{P(E \cap F) + P(\bar{E} \cap F)}{P(F)} = \frac{P(F)}{P(F)} = 1$$

Therefore, option (a) is correct.

$$(b) P(E/F) + P(E/\bar{F}) = \frac{P(E \cap F)}{P(F)} + \frac{P(E \cap \bar{F})}{P(\bar{F})}$$

$$= \frac{P(E \cap F)}{P(F)} + \frac{P(E \cap \bar{F})}{1 - P(F)} \neq 1$$

Therefore, option (b) is not correct.

$$(c) P(\bar{E}/F) + P(E/\bar{F}) = \frac{P(\bar{E} \cap F)}{P(F)} + \frac{P(E \cap \bar{F})}{P(\bar{F})}$$

$$= \frac{P(\bar{E} \cap F)}{P(F)} + \frac{P(E \cap \bar{F})}{1 - P(F)} \neq 1$$

Therefore, option (c) is not correct.

$$(d) P(E/\bar{F}) + P(\bar{E}/F) = \frac{P(E \cap \bar{F})}{P(\bar{F})} + \frac{P(\bar{E} \cap F)}{P(F)}$$

$$= \frac{P(E \cap \bar{F}) + P(\bar{E} \cap F)}{P(\bar{F})} = \frac{P(\bar{F})}{P(\bar{F})} = 1$$

Therefore, option (d) is correct.

26. Both E and F happen $\Rightarrow P(E \cap F) = \frac{1}{12}$

and neither E nor F happens $\Rightarrow P(\bar{E} \cap \bar{F}) = \frac{1}{2}$

But for independent events, we have

$$P(E \cap F) = P(E)P(F) = \frac{1}{12} \quad \dots(i)$$

and $P(\bar{E} \cap \bar{F}) = P(\bar{E})P(\bar{F})$

$$= \{1 - P(E)\}\{1 - P(F)\}$$

$$= 1 - P(E) - P(F) + P(E)P(F)$$

$$\Rightarrow \frac{1}{2} = 1 - \{P(E) + P(F)\} + \frac{1}{12}$$

$$\Rightarrow P(E) + P(F) = 1 - \frac{1}{2} + \frac{1}{12} = \frac{7}{12} \quad \dots(ii)$$

On solving Eqs. (i) and (ii), we get

either $P(E) = \frac{1}{3}$ and $P(F) = \frac{1}{4}$

or $P(E) = \frac{1}{4}$ and $P(F) = \frac{1}{3}$

27. We know that,

$$P\left(\frac{A}{B}\right) = \frac{P(A \cap B)}{P(B)} = \frac{P(A) + P(B) - P(A \cup B)}{P(B)}$$

Since, $P(A \cup B) < 1$

$$\Rightarrow -P(A \cup B) > -1$$

$$\Rightarrow P(A) + P(B) - P(A \cup B) > P(A) + P(B) - 1$$

$$\Rightarrow \frac{P(A) + P(B) - P(A \cup B)}{P(B)} > \frac{P(A) + P(B) - 1}{P(B)}$$

$$\Rightarrow P\left(\frac{A}{B}\right) > \frac{P(A) + P(B) - 1}{P(B)}$$

Hence, option (a) is correct.

The choice (b) holds only for disjoint i.e. $P(A \cap B) = 0$

Finally, $P(A \cup B) = P(A) + P(B) - P(A \cap B)$

$$= P(A) + P(B) - P(A) \cdot P(B),$$

if A, B are independent

$$= 1 - \{1 - P(A)\}\{1 - P(B)\}$$

$$= 1 - P(A) \cdot P(B)$$

Hence, option (c) is correct, but option (d) is not correct.

28. Since, E and F are independent events. Therefore, $P(E \cap F) = P(E) \cdot P(F) \neq 0$, so E and F are not mutually exclusive events.

Now, $P(E \cap \bar{F}) = P(E) - P(E \cap F) = P(E) - P(E) \cdot P(F)$

$$= P(E) [1 - P(F)] = P(E) \cdot P(\bar{F})$$

and $P(\bar{E} \cap \bar{F}) = P(\bar{E} \cup \bar{F}) = 1 - P(E \cup F)$

$$= 1 - [1 - P(\bar{E}) \cdot P(\bar{F})]$$

[$\because E$ and F are independent]

$$= P(\bar{E}) \cdot P(\bar{F})$$

So, E and \bar{F} as well as \bar{E} and \bar{F} are independent events.

Now, $P(E/F) + P(\bar{E}/F) = \frac{P(E \cap F) + P(\bar{E} \cap F)}{P(F)}$

$$= \frac{P(F)}{P(F)} = 1$$

29. $P(A^c) = 0.3$ [given]

$$\Rightarrow P(A) = 0.7$$

$$P(B) = 0.4$$
 [given]

$$\Rightarrow P(B^c) = 0.6$$
 and $P(A \cap B^c) = 0.5$ [given]

Now, $P(A \cup B^c) = P(A) + P(B^c) - P(A \cap B^c)$

$$= 0.7 + 0.6 - 0.5 = 0.8$$

$$\therefore P[B/(A \cup B^c)] = \frac{P\{B \cap (A \cup B^c)\}}{P(A \cup B^c)}$$

$$= \frac{P\{(B \cap A) \cup (B \cap B^c)\}}{0.8} = \frac{P\{(B \cap A) \cup \phi\}}{0.8} = \frac{P(B \cap A)}{0.8}$$

$$= \frac{1}{0.8} [P(A) - P(A \cap B^c)]$$

$$= \frac{0.7 - 0.5}{0.8} = \frac{0.2}{0.8} = \frac{1}{4}$$

30. $P(A \cup B) = P(A) + P(B) - P(A)P(B)$, as A and B are independent events.

$$\Rightarrow 0.8 = (0.3) + P(B) - (0.3)P(B)$$

$$\Rightarrow 0.5 = (0.7)P(B) \Rightarrow P(B) = \frac{5}{7}$$

31. 5 can be thrown in 4 ways and 7 can be thrown in 6 ways, hence number of ways of throwing neither 5 nor 7 is $36 - (4 + 6) = 26$

\therefore Probability of throwing a five in a single throw with a pair of dice $= \frac{4}{36} = \frac{1}{9}$ and probability of throwing neither

$$5 \text{ nor } 7 = \frac{26}{36} = \frac{13}{18}$$

Hence, required probability

$$= \left(\frac{1}{9}\right) + \left(\frac{13}{18}\right)\left(\frac{1}{9}\right) + \left(\frac{13}{18}\right)^2\left(\frac{1}{9}\right) + \dots = \frac{\frac{1}{9}}{1 - \frac{13}{18}} = \frac{2}{5}$$

32. Let R be drawing a red ball and B for drawing a black ball, then required probability

$$= RRR + RBR + BRR + BBR$$

$$= \left(\frac{6}{10} \times \frac{5}{11} \times \frac{6}{10}\right) + \left(\frac{6}{10} \times \frac{6}{11} \times \frac{5}{10}\right)$$

$$+ \left(\frac{4}{10} \times \frac{4}{11} \times \frac{7}{10}\right) + \left(\frac{4}{10} \times \frac{7}{11} \times \frac{6}{10}\right)$$

$$= \frac{640}{1100} = \frac{32}{55}$$

124 Probability

33. Let A be the event that the maximum number on the two chosen tickets is not more than 10, and B be the event that the minimum number on them is 5

$$\therefore P(A \cap B) = \frac{{}^5C_1}{{}^{100}C_2}$$

$$\text{and } P(A) = \frac{{}^{10}C_2}{{}^{100}C_2}$$

$$\begin{aligned} \text{Then } P\left(\frac{B}{A}\right) &= \frac{P(A \cap B)}{P(A)} \\ &= \frac{{}^5C_1}{{}^{10}C_2} = \frac{1}{9} \end{aligned}$$

34. Here, $P(A \cup B) \cdot P(A' \cap B')$
 $\Rightarrow \{P(A) + P(B) - P(A \cap B)\} \{P(A') \cdot P(B')\}$
 [since A, B are independent, so A', B' are independent]
 $\therefore P(A \cup B) \cdot P(A' \cap B') \leq \{P(A) + P(B)\} \cdot \{P(A') \cdot P(B')\}$
 $= P(A) \cdot P(A') \cdot P(B') + P(B) \cdot P(A') \cdot P(B')$
 $\leq P(A) \cdot P(B') + P(B) \cdot P(A') \quad \dots(i)$
 $[\because P(A') \leq 1 \text{ and } P(B') \leq 1]$
 $\Rightarrow P(A \cup B) \cdot P(A' \cap B') \leq P(A) \cdot P(B') + P(B) \cdot P(A')$
 $\Rightarrow P(A \cup B) \cdot P(A' \cap B') \leq P(C)$
 $[\because P(C) = P(A) \cdot P(B') + P(B) \cdot P(A')]$

35. Given, $P(A) =$ probability that A will hit $B = \frac{2}{3}$

$$P(B) = \text{probability that } B \text{ will hit } A = \frac{1}{2}$$

$$P(C) = \text{probability that } C \text{ will hit } A = \frac{1}{3}$$

$$\begin{aligned} P(E) &= \text{probability that } A \text{ will be hit} \\ \Rightarrow P(E) &= 1 - P(\bar{B}) \cdot P(\bar{C}) = 1 - \frac{1}{2} \cdot \frac{2}{3} = \frac{2}{3} \end{aligned}$$

Probability if A is hit by B and not by C

$$= P(B \cap \bar{C} / E) = \frac{P(B) \cdot P(\bar{C})}{P(E)} = \frac{\frac{1}{2} \cdot \frac{2}{3}}{\frac{2}{3}} = \frac{1}{2}$$

36. Let E_i denotes the event that the students will pass the i th exam, where $i = 1, 2, 3$
 and E denotes the student will qualify.

$$\begin{aligned} \therefore P(E) &= [P(E_1) \times P(E_2 / E_1)] \\ &\quad + [P(E_1) \times P(E_2' / E_1) \times P(E_3 / E_2')] \\ &\quad + [P(E_1') \times P(E_2 / E_1') \times P(E_3 / E_2)] \\ &= p^2 + p(1-p) \cdot \frac{p}{2} + (1-p) \cdot \frac{p}{2} \cdot p \\ \Rightarrow P(E) &= \frac{2p^2 + p^2 - p^3 + p^2 - p^3}{2} = 2p^2 - p^3 \end{aligned}$$

37. Since, p_n denotes the probability that no two (or more) consecutive heads occur.

$\Rightarrow p_n$ denotes the probability that 1 or no head occur.

For $n = 1$, $p_1 = 1$ because in both cases we get less than two heads (H, T).

For $n = 2$, $p_2 = 1 - p$ (two heads simultaneously occur).

$$= 1 - p(HH) = 1 - pp = 1 - p^2$$

For $n \geq 3$, $p_n = p_{n-1}(1-p) + p_{n-2}(1-p)p$

$$\Rightarrow p_n = (1-p)p_{n-1} + p(1-p)p_{n-2}$$

Hence proved.

38. Let, $E_1 =$ the event noted number is 7

$E_2 =$ the event noted number is 8

$H =$ getting head on coin

$T =$ be getting tail on coin

\therefore By law of total probability,

$$P(E_1) = P(H) \cdot P(E_1 / H) + P(T) \cdot P(E_1 / T)$$

and $P(E_2) = P(H) \cdot P(E_2 / H) + P(T) \cdot P(E_2 / T)$

where, $P(H) = 1/2 = P(T)$

$P(E_1 / H) =$ probability of getting a sum of 7 on two dice

Here, favourable cases are

$$\{(1, 6), (6, 1), (2, 5), (5, 2), (3, 4), (4, 3)\}.$$

$$\therefore P(E_1 / H) = \frac{6}{36} = \frac{1}{6}$$

Also, $P(E_1 / T) =$ probability of getting 7 numbered card out of 11 cards

$$= \frac{1}{11}$$

$P(E_2 / H) =$ probability of getting a sum of 8 on two dice

Here, favourable cases are

$$\{(2, 6), (6, 2), (4, 4), (5, 3), (3, 5)\}.$$

$$\therefore P(E_2 / H) = \frac{5}{36}$$

$P(E_2 / T) =$ probability of getting '8' numbered card out of 11 cards

$$= 1/11$$

$$\therefore P(E_1) = \left(\frac{1}{2} \times \frac{1}{6}\right) + \left(\frac{1}{2} \times \frac{1}{11}\right) = \frac{1}{12} + \frac{1}{22} = \frac{17}{132}$$

$$\text{and } P(E_2) = \left(\frac{1}{2} \times \frac{5}{36}\right) + \left(\frac{1}{2} \times \frac{1}{11}\right)$$

$$= \frac{1}{2} \left(\frac{91}{396}\right) = \frac{91}{792}$$

Now, E_1 and E_2 are mutually exclusive events.

Therefore,

$$P(E_1 \text{ or } E_2) = P(E_1) + P(E_2) = \frac{17}{132} + \frac{91}{792} = \frac{193}{792}$$

39. Let D_1 denotes the occurrence of a defective bulb in Ist draw.

$$\text{Therefore, } P(D_1) = \frac{50}{100} = \frac{1}{2}$$

and let D_2 denotes the occurrence of a defective bulb in IInd draw.

$$\text{Therefore, } P(D_2) = \frac{50}{100} = \frac{1}{2}$$

and let N_1 denotes the occurrence of non-defective bulb in Ist draw.

Therefore, $P(N_1) = \frac{50}{100} = \frac{1}{2}$

Again, let N_2 denotes the occurrence of non-defective bulb in IInd draw.

Therefore, $P(N_2) = \frac{50}{100} = \frac{1}{2}$

Now, D_1 is independent with N_1 and D_2 is independent with N_2 .

According to the given condition,

$A = \{\text{the first bulb is defective}\} = \{D_1D_2, D_1N_2\}$

$B = \{\text{the second bulb is non-defective}\} = \{D_1N_2, N_1N_2\}$

and $C = \{\text{the two bulbs are both defective}\} = \{D_1D_2, N_1N_2\}$

Again, we know that,

$A \cap B = \{D_1N_2\}, B \cap C = \{N_1N_2\}.$

$C \cap A = \{D_1D_2\}$ and $A \cap B \cap C = \phi$

Also, $P(A) = P\{D_1D_2\} + P\{D_1N_2\}$
 $= P(D_1)P(D_2) + P(D_1)P(N_2)$
 $= \left(\frac{1}{2}\right)\left(\frac{1}{2}\right) + \left(\frac{1}{2}\right)\left(\frac{1}{2}\right) = \frac{1}{2}$

Similarly, $P(B) = \frac{1}{2}$ and $P(C) = \frac{1}{2}$

Also, $P(A \cap B) = P(D_1N_2) = P(D_1)P(N_2) = \left(\frac{1}{2}\right)\left(\frac{1}{2}\right) = \frac{1}{4}$

Similarly, $P(B \cap C) = \frac{1}{4}, P(C \cap A) = \frac{1}{4}$

and $P(A \cap B \cap C) = 0.$

Since, $P(A \cap B) = P(A)P(B), P(B \cap C) = P(B)P(C)$

and $P(C \cap A) = P(C)P(A).$

Therefore, A, B and C are pairwise independent.

Also, $P(A \cap B \cap C) \neq P(A)P(B)P(C)$ therefore A, B and C cannot be independent.

40. The total number of ways to answer the question
 $= {}^4C_1 + {}^4C_2 + {}^4C_3 + {}^4C_4 = 2^4 - 1 = 15$

$P(\text{getting marks}) = P(\text{correct answer in I chance})$
 $+ P(\text{correct answer in II chance})$
 $+ P(\text{correct answer in III chance})$
 $= \frac{1}{15} + \left(\frac{14}{15} \cdot \frac{1}{14}\right) + \left(\frac{14}{15} \cdot \frac{13}{14} \cdot \frac{1}{13}\right) = \frac{3}{15} = \frac{1}{5}$

41. Given, $P(A) \cdot P(B) = \frac{1}{6}, P(\bar{A}) \cdot P(\bar{B}) = \frac{1}{3}$

$\therefore [1 - P(A)] [1 - P(B)] = \frac{1}{3}$

Let $P(A) = x$ and $P(B) = y$

$\Rightarrow (1 - x)(1 - y) = \frac{1}{3}$ and $xy = \frac{1}{6}$

$\Rightarrow 1 - x - y + xy = \frac{1}{3}$ and $xy = \frac{1}{6}$

$\Rightarrow x + y = \frac{5}{6}$ and $xy = \frac{1}{6}$

$\Rightarrow x\left(\frac{5}{6} - x\right) = \frac{1}{6}$

$\Rightarrow 6x^2 - 5x + 1 = 0$

$\Rightarrow (3x - 1)(2x - 1) = 0$

$\Rightarrow x = \frac{1}{3}$ and $\frac{1}{2}$

$\therefore P(A) = \frac{1}{3}$ or $\frac{1}{2}$

42. $P(N\text{th draw gives 2nd ace})$
 $= P\{1 \text{ ace and } (n - 2) \text{ other cards are drawn in } (N - 1) \text{ draws}\} \times P\{N\text{th draw is 2nd ace}\}$
 $= \frac{4 \cdot (48)! \cdot (n - 1)! (52 - n)!}{(52)! \cdot (n - 2)! (50 - n)!} \cdot \frac{3}{(53 - n)}$
 $= \frac{4(n - 1)(52 - n)(51 - n) \cdot 3}{52 \cdot 51 \cdot 50 \cdot 49}$
 $= \frac{(n - 1)(52 - n)(51 - n)}{50 \cdot 49 \cdot 17 \cdot 13}$

43. Let $P(H_1) = 0.4, P(H_2) = 0.3, P(H_3) = 0.2, P(H_4) = 0.1$
 $P(\text{gun hits the plane})$
 $= 1 - P(\text{gun does not hit the plane})$
 $= 1 - P(\bar{H}_1) \cdot P(\bar{H}_2) \cdot P(\bar{H}_3) \cdot P(\bar{H}_4)$
 $= 1 - (0.6)(0.7)(0.8)(0.9) = 1 - 0.3024 = 0.6976$

44. Since, the drawn balls are in the sequence black, black, white, white, white, white, red, red and red. Let the corresponding probabilities be

p_1, p_2, \dots, p_9
 Then, $p_1 = \frac{2}{9}, p_2 = \frac{1}{8}, p_3 = \frac{4}{7}, p_4 = \frac{3}{6}, p_5 = \frac{2}{5}$
 $p_6 = \frac{1}{4}, p_7 = \frac{3}{3}, p_8 = \frac{2}{2}, p_9 = 1$

\therefore Required probability
 $p_1 \cdot p_2 \cdot p_3 \cdot \dots \cdot p_9$
 $= \left(\frac{2}{9}\right)\left(\frac{1}{8}\right)\left(\frac{4}{7}\right)\left(\frac{3}{6}\right)\left(\frac{2}{5}\right)\left(\frac{1}{4}\right)\left(\frac{3}{3}\right)\left(\frac{2}{2}\right)(1) = \frac{1}{1260}$

45. Given sample space (S) of all 3×3 matrices with entries from the set $\{0, 1\}$ and events
 $E_1 = \{A \in S : \det(A) = 0\}$ and
 $E_2 = \{A \in S : \text{sum of entries of } A \text{ is } 7\}$
 For event E_2 , means sum of entries of matrix A is 7, then we need seven 1s and two 0s.
 \therefore Number of different possible matrices = $\frac{9!}{7!2!}$

$\Rightarrow n(E_2) = 36$

For event $E_1, |A| = 0$, both the zeroes must be in same row/column.

\therefore Number of matrices such that their determinant is zero

$= 6 \times \frac{3!}{2!} = 18 = n(E_1 \cap E_2)$

\therefore Required probability, $P\left(\frac{E_1}{E_2}\right) = \frac{n(E_1 \cap E_2)}{n(E_2)}$
 $= \frac{18}{36} = \frac{1}{2} = 0.50$

126 Probability

46. PLAN

For the events to be independent,

$$P(E_1 \cap E_2 \cap E_3) = P(E_1) \cdot P(E_2) \cdot P(E_3)$$

$$P(E_1 \cap \bar{E}_2 \cap \bar{E}_3) = P(\text{only } E_1 \text{ occurs}) \\ = P(E_1) \cdot (1 - P(E_2)) \cdot (1 - P(E_3))$$

Let x, y and z be probabilities of E_1, E_2 and E_3 , respectively.

$$\therefore \alpha = x(1 - y)(1 - z) \quad \dots(i)$$

$$\beta = (1 - x) \cdot y(1 - z) \quad \dots(ii)$$

$$\gamma = (1 - x)(1 - y)z \quad \dots(iii)$$

$$\Rightarrow p = (1 - x)(1 - y)(1 - z) \quad \dots(iv)$$

$$\text{Given, } (\alpha - 2\beta)p = \alpha\beta \text{ and } (\beta - 3\gamma)p = 2\beta\gamma \quad \dots(v)$$

From above equations, $x = 2y$ and $y = 3z$

$$\therefore x = 6z$$

$$\Rightarrow \frac{x}{z} = 6$$

$$47. \text{ Here, } P(X > Y) = P(T_1 \text{ win}) P(T_1 \text{ win}) \\ + P(T_1 \text{ win}) P(\text{draw}) + P(\text{draw}) P(T_1 \text{ win}) \\ = \left(\frac{1}{2} \times \frac{1}{2}\right) + \left(\frac{1}{2} \times \frac{1}{6}\right) + \left(\frac{1}{6} \times \frac{1}{2}\right) = \frac{5}{12}$$

$$48. P[X = Y] = P(\text{draw}) \cdot P(\text{draw}) \\ + P(T_1 \text{ win}) P(T_2 \text{ win}) + P(T_2 \text{ win}) \cdot P(T_1 \text{ win}) \\ = (1/6 \times 1/6) + (1/2 \times 1/3) + (1/3 \times 1/2) = 13/36$$

Topic 4 Law of Total Probability and Baye's Theorem

1. Let A be the event that ball drawn is given and B be the event that ball drawn is red.

$$\therefore P(A) = \frac{2}{7} \text{ and } P(B) = \frac{5}{7}$$

Again, let C be the event that second ball drawn is red.

$$\therefore P(C) = P(A) P(C|A) + P(B) P(C|B) \\ = \frac{2}{7} \times \frac{6}{7} + \frac{5}{7} \times \frac{4}{7} \\ = \frac{12 + 20}{49} = \frac{32}{49}$$

2. **Key idea** Use the theorem of total probability

Let E_1 = Event that first ball drawn is red

E_2 = Event that first ball drawn is black

A = Event that second ball drawn is red

$$P(E_1) = \frac{4}{10}, P\left(\frac{A}{E_1}\right) = \frac{6}{12}$$

$$\Rightarrow P(E_2) = \frac{6}{10}, P\left(\frac{A}{E_2}\right) = \frac{4}{12}$$

By law of total probability

$$P(A) = P(E_1) \times P\left(\frac{A}{E_1}\right) + P(E_2) \times P\left(\frac{A}{E_2}\right) \\ = \frac{4}{10} \times \frac{6}{12} + \frac{6}{10} \times \frac{4}{12} = \frac{24 + 24}{120} = \frac{48}{120} = \frac{2}{5}$$

3. Let $x = P$ (computer turns out to be defective, given that it is produced in plant T_2)

$$\Rightarrow x = P\left(\frac{D}{T_2}\right) \quad \dots(i)$$

where, D = Defective computer

$\therefore P$ (computer turns out to be defective given that is produced in plant T_1) = $10x$

$$\text{i.e. } P\left(\frac{D}{T_1}\right) = 10x \quad \dots(ii)$$

$$\text{Also, } P(T_1) = \frac{20}{100} \text{ and } P(T_2) = \frac{80}{100}$$

$$\text{Given, } P(\text{defective computer}) = \frac{7}{100}$$

$$\text{i.e. } P(D) = \frac{7}{100}$$

Using law of total probability,

$$P(D) = 9(T_1) \cdot P\left(\frac{D}{T_1}\right) + P(T_2) \cdot P\left(\frac{D}{T_2}\right)$$

$$\therefore \frac{7}{100} = \left(\frac{20}{100}\right) \cdot 10x + \left(\frac{80}{100}\right) \cdot x$$

$$\Rightarrow 7 = (280)x \Rightarrow x = \frac{1}{40} \quad \dots(iii)$$

$$\therefore P\left(\frac{D}{T_2}\right) = \frac{1}{40} \text{ and } P\left(\frac{D}{T_1}\right) = \frac{10}{40}$$

$$\Rightarrow P\left(\frac{\bar{D}}{T_2}\right) = 1 - \frac{1}{40} = \frac{39}{40} \text{ and } P\left(\frac{\bar{D}}{T_1}\right) = 1 - \frac{10}{40} = \frac{30}{40} \quad \dots(iv)$$

Using Baye's theorem,

$$P\left(\frac{T_2}{\bar{D}}\right) = \frac{P(T_2 \cap \bar{D})}{P(T_1 \cap \bar{D}) + P(T_2 \cap \bar{D})} \\ = \frac{P(T_2) \cdot P\left(\frac{\bar{D}}{T_2}\right)}{P(T_1) \cdot P\left(\frac{\bar{D}}{T_1}\right) + P(T_2) \cdot P\left(\frac{\bar{D}}{T_2}\right)} \\ = \frac{\frac{80}{100} \cdot \frac{39}{40}}{\frac{20}{100} \cdot \frac{30}{40} + \frac{80}{100} \cdot \frac{39}{40}} = \frac{78}{93}$$

4. From the tree diagram, it follows that

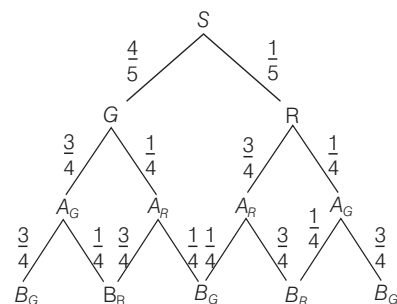

$$\begin{aligned}
 P(B_G) &= \frac{46}{80} \\
 P(\bar{B}_G|G) &= \frac{10}{16} = \frac{5}{8} \\
 P(B_G \cap G) &= \frac{5}{8} \times \frac{4}{5} = \frac{1}{2} \\
 \therefore P(G|B_G) &= \frac{\frac{1}{2}}{\frac{46}{80}} = \frac{1}{2} \times \frac{80}{46} = \frac{20}{23}
 \end{aligned}$$

5. **Key Idea** Use conditional probability, total probability and Baye's theorem.

It is given that there are three bags B_1, B_2 and B_3 and probabilities of being chosen B_1, B_2 and B_3 are respectively

$$\therefore P(B_1) = \frac{3}{10}, P(B_2) = \frac{3}{10} \text{ and } P(B_3) = \frac{4}{10}.$$

$\begin{array}{ c } \hline 5 R \\ \hline 5 G \\ \hline \end{array}$	$\begin{array}{ c } \hline 3 R \\ \hline 5 G \\ \hline \end{array}$	$\begin{array}{ c } \hline 5 R \\ \hline 3 G \\ \hline \end{array}$
B_1	B_2	B_3

Now, probability that the chosen ball is green, given that selected bag is $B_3 = P\left(\frac{G}{B_3}\right) = \frac{3}{8}$

Now, probability that the selected bag is B_3 , given that the chosen ball is green = $P\left(\frac{B_3}{G}\right)$

$$\begin{aligned}
 & \frac{P\left(\frac{G}{B_3}\right) P(B_3)}{P\left(\frac{G}{B_1}\right) P(B_1) + P\left(\frac{G}{B_2}\right) P(B_2) + P\left(\frac{G}{B_3}\right) P(B_3)} \quad [\text{by Baye's theorem}] \\
 &= \frac{\left(\frac{3}{8} \times \frac{4}{10}\right)}{\left(\frac{5}{10} \times \frac{3}{10}\right) + \left(\frac{5}{8} \times \frac{3}{10}\right) + \left(\frac{3}{8} \times \frac{4}{10}\right)} = \frac{\frac{1}{2}}{\frac{1}{2} + \frac{5}{8} + \frac{1}{2}} = \frac{4}{13}
 \end{aligned}$$

Now, probability that the chosen ball is green = $P(G) = P(B_1)P\left(\frac{G}{B_1}\right) + P(B_2)P\left(\frac{G}{B_2}\right) + P(B_3)P\left(\frac{G}{B_3}\right)$

$$\begin{aligned}
 & [\text{By using theorem of total probability}] \\
 &= \left(\frac{3}{10} \times \frac{5}{10}\right) + \left(\frac{3}{10} \times \frac{5}{8}\right) + \left(\frac{4}{10} \times \frac{3}{8}\right) \\
 &= \frac{3}{20} + \frac{3}{16} + \frac{3}{20} = \frac{12 + 15 + 12}{80} = \frac{39}{80}
 \end{aligned}$$

Now, probability that the selected bag is B_3 and the chosen ball is green = $P(B_3) \times P\left(\frac{G}{B_3}\right) = \frac{4}{10} \times \frac{3}{8} = \frac{3}{20}$

Hence, options (a) and (c) are correct.

6. **PLAN** It is based on law of total probability and Bay's Law.

Description of Situation It is given that ship would work if atleast two of engines must work. If X be event that the ship works. Then, $X \Rightarrow$ either any two of E_1, E_2, E_3 works or all three engines E_1, E_2, E_3 works.

Given, $P(E_1) = \frac{1}{2}, P(E_2) = \frac{1}{4}, P(E_3) = \frac{1}{4}$

$$\begin{aligned}
 \therefore P(X) &= \left\{ P(E_1 \cap E_2 \cap \bar{E}_3) + P(E_1 \cap \bar{E}_2 \cap E_3) \right. \\
 & \quad \left. + P(\bar{E}_1 \cap E_2 \cap E_3) + P(E_1 \cap E_2 \cap E_3) \right\} \\
 &= \left(\frac{1}{2} \cdot \frac{1}{4} \cdot \frac{3}{4} + \frac{1}{2} \cdot \frac{3}{4} \cdot \frac{1}{4} + \frac{1}{2} \cdot \frac{1}{4} \cdot \frac{1}{4} \right) + \left(\frac{1}{2} \cdot \frac{1}{4} \cdot \frac{1}{4} \right) \\
 &= 1/4
 \end{aligned}$$

Now, (a) $P(X_1^c | X)$

$$= P\left(\frac{X_1^c \cap X}{X}\right) = \frac{P(\bar{E}_1 \cap E_2 \cap E_3)}{P(X)} = \frac{\frac{1}{2} \cdot \frac{1}{4} \cdot \frac{1}{4}}{\frac{1}{4}} = \frac{1}{8}$$

(b) P (exactly two engines of the ship are functioning)

$$\begin{aligned}
 &= \frac{P(E_1 \cap E_2 \cap \bar{E}_3) + P(E_1 \cap \bar{E}_2 \cap E_3) + P(\bar{E}_1 \cap E_2 \cap E_3)}{P(X)} \\
 &= \frac{\frac{1}{2} \cdot \frac{1}{4} \cdot \frac{3}{4} + \frac{1}{2} \cdot \frac{3}{4} \cdot \frac{1}{4} + \frac{1}{2} \cdot \frac{1}{4} \cdot \frac{1}{4}}{\frac{1}{4}} = \frac{7}{8}
 \end{aligned}$$

(c) $P\left(\frac{X}{X_2}\right) = \frac{P(X \cap X_2)}{P(X_2)}$

$$\begin{aligned}
 &= \frac{P(\text{ship is operating with } E_2 \text{ function})}{P(X_2)} \\
 &= \frac{P(E_1 \cap E_2 \cap \bar{E}_3) + P(\bar{E}_1 \cap E_2 \cap E_3) + P(E_1 \cap E_2 \cap E_3)}{P(E_2)} \\
 &= \frac{\frac{1}{2} \cdot \frac{1}{4} \cdot \frac{3}{4} + \frac{1}{2} \cdot \frac{1}{4} \cdot \frac{1}{4} + \frac{1}{2} \cdot \frac{1}{4} \cdot \frac{1}{4}}{\frac{1}{4}} = \frac{5}{8}
 \end{aligned}$$

(d) $P(X|X_1) = \frac{P(X \cap X_1)}{P(X_1)}$

$$\begin{aligned}
 &= \frac{\frac{1}{2} \cdot \frac{1}{4} \cdot \frac{1}{4} + \frac{1}{2} \cdot \frac{3}{4} \cdot \frac{1}{4} + \frac{1}{2} \cdot \frac{1}{4} \cdot \frac{3}{4}}{1/2} \\
 &= \frac{7}{16}
 \end{aligned}$$

7. **Statement I** If $P(H_i \cap E) = 0$ for some i , then

$$P\left(\frac{H_i}{E}\right) = P\left(\frac{E}{H_i}\right) = 0$$

If $P(H_i \cap E) \neq 0, \forall i = 1, 2, \dots, n$, then

$$\begin{aligned}
 P\left(\frac{H_i}{E}\right) &= \frac{P(H_i \cap E)}{P(H_i)} \times \frac{P(H_i)}{P(E)} \\
 &= \frac{P\left(\frac{E}{H_i}\right) \times P(H_i)}{P(E)} > P\left(\frac{E}{H_i}\right) \cdot P(H_i) \quad [\because 0 < P(E) < 1]
 \end{aligned}$$

Hence, Statement I may not always be true.

Statement II Clearly, $H_1 \cup H_2 \cup \dots \cup H_n = S$ [sample space]

$$\Rightarrow P(H_1) + P(H_2) + \dots + P(H_n) = 1$$

Hence, Statement II is true.

Passage I

8.

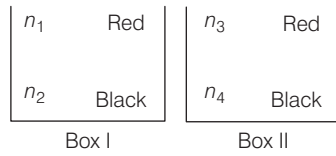

Let $A = \text{Drawing red ball}$
 $\therefore P(A) = P(B_1) \cdot P(A/B_1) + P(B_2) \cdot P(A/B_2)$
 $= \frac{1}{2} \left(\frac{n_1}{n_1 + n_2} \right) + \frac{1}{2} \left(\frac{n_3}{n_3 + n_4} \right)$

Given, $P(B_2/A) = \frac{1}{3}$
 $\Rightarrow \frac{P(B_2) \cdot P(B_2 \cap A)}{P(A)} = \frac{1}{3}$

$\Rightarrow \frac{\frac{1}{2} \left(\frac{n_3}{n_3 + n_4} \right)}{\frac{1}{2} \left(\frac{n_1}{n_1 + n_2} \right) + \frac{1}{2} \left(\frac{n_3}{n_3 + n_4} \right)} = \frac{1}{3}$
 $\Rightarrow \frac{n_3(n_1 + n_2)}{n_1(n_3 + n_4) + n_3(n_1 + n_2)} = \frac{1}{3}$

Now, check options, then clearly options (a) and (b) satisfy.

9.

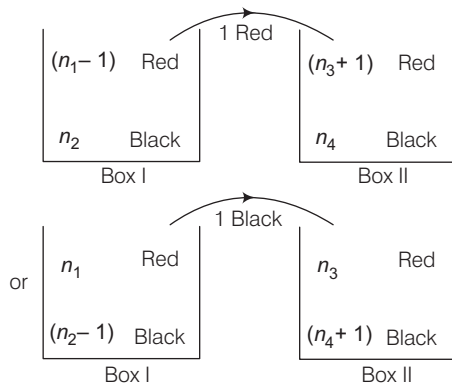

$\therefore P(\text{drawing red ball from } B_1) = \frac{1}{3}$
 $\Rightarrow \left(\frac{n_1 - 1}{n_1 + n_2 - 1} \right) \left(\frac{n_1}{n_1 + n_2} \right) + \left(\frac{n_2}{n_1 + n_2} \right) \left(\frac{n_1}{n_1 + n_2 - 1} \right) = \frac{1}{3}$
 $\Rightarrow \frac{n_1^2 + n_1 n_2 - n_1}{(n_1 + n_2)(n_1 + n_2 - 1)} = \frac{1}{3}$

Clearly, options (c) and (d) satisfy.

Passage II

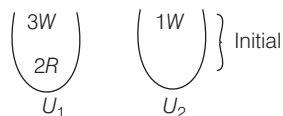

Head appears

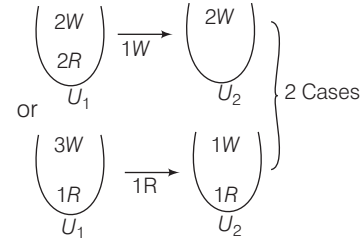

Tail appears

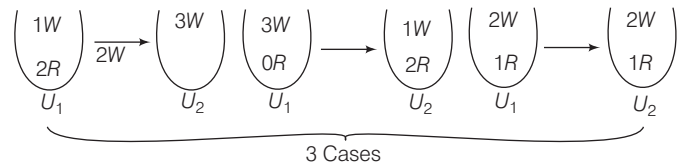

10. Now, probability of the drawn ball from U_2 being white is

$P(\text{white} / U_2) = P(H) \cdot \left[\frac{{}^3C_1}{{}^5C_1} \times \frac{{}^2C_1}{{}^2C_1} + \frac{{}^2C_1}{{}^5C_1} \times \frac{{}^1C_1}{{}^2C_1} \right]$
 $+ P(T) \left[\frac{{}^3C_2}{{}^5C_2} \times \frac{{}^3C_2}{{}^3C_2} + \frac{{}^2C_2}{{}^5C_2} \times \frac{{}^1C_1}{{}^3C_2} + \frac{{}^3C_1 \cdot {}^2C_1}{{}^5C_2} \times \frac{{}^2C_1}{{}^3C_2} \right]$
 $= \frac{1}{2} \left[\frac{3}{5} \times 1 + \frac{2}{5} \times \frac{1}{2} \right]$
 $+ \frac{1}{2} \left[\frac{3}{10} \times 1 + \frac{1}{10} \times \frac{1}{3} + \frac{6}{10} \times \frac{2}{3} \right] = \frac{23}{30}$

11. $P(\text{Head appeared/white from } U_2)$

$= P(H) \cdot \frac{\left[\frac{{}^3C_1}{{}^5C_1} \times \frac{{}^2C_1}{{}^2C_1} + \frac{{}^2C_1}{{}^5C_1} \times \frac{{}^1C_1}{{}^2C_1} \right]}{23/30}$
 $= \frac{1}{2} \left[\frac{3}{5} \times 1 + \frac{2}{5} \times \frac{1}{2} \right]$
 $= \frac{12}{23}$

Passage III

12. $P(X = 3) = \frac{5}{6} \cdot \frac{5}{6} \cdot \frac{1}{6} = \frac{25}{216}$

13. $P(X \geq 3) = \frac{5}{6} \cdot \frac{5}{6} \cdot 1 = \frac{25}{36}$

14. $P\{(X \geq 6) / (X > 3)\} = \frac{P\{(X > 3) / (X \geq 6)\} \cdot P(X \geq 6)}{P(X > 3)}$

$= \frac{1 \cdot \left[\left(\frac{5}{6} \right)^5 \cdot \left(\frac{1}{6} \right) + \left(\frac{5}{6} \right)^6 \cdot \left(\frac{1}{6} \right) + \dots \infty \right]}{\left[\left(\frac{5}{6} \right)^3 \cdot \frac{1}{6} + \left(\frac{5}{6} \right)^4 \cdot \frac{1}{6} + \dots \infty \right]} = \frac{25}{36}$

Passage IV

15. Here, $P(u_i) = ki, \Sigma P(u_i) = 1 \Rightarrow k = \frac{2}{n(n+1)}$

$$\begin{aligned} \lim_{n \rightarrow \infty} P(W) &= \lim_{n \rightarrow \infty} \sum_{i=1}^n \frac{2i^2}{n(n+1)^2} \\ &= \lim_{n \rightarrow \infty} \frac{2n(n+1)(2n+1)}{6n(n+1)^2} = 2/3 \end{aligned}$$

16. $P\left(\frac{u_n}{W}\right) = \frac{n+1}{\Sigma i} = \frac{2}{n+1}$

17. $P\left(\frac{W}{E}\right) = \frac{2+4+6+\dots}{n(n+1)} = \frac{n+2}{2(n+1)}$

18. As, the statement shows problem is to be related to Baye's law.

Let C, S, B, T be the events when person is going by car, scooter, bus or train, respectively.

$\therefore P(C) = \frac{1}{7}, P(S) = \frac{3}{7}, P(B) = \frac{2}{7}, P(T) = \frac{1}{7}$

Again, L be the event of the person reaching office late.

$\therefore \bar{L}$ be the event of the person reaching office in time.

Then, $P\left(\frac{\bar{L}}{C}\right) = \frac{7}{9}, P\left(\frac{\bar{L}}{S}\right) = \frac{8}{9}, P\left(\frac{\bar{L}}{B}\right) = \frac{5}{9}$

and $P\left(\frac{\bar{L}}{T}\right) = \frac{8}{9}$

$$\begin{aligned} \therefore P\left(\frac{C}{\bar{L}}\right) &= \frac{P\left(\frac{\bar{L}}{C}\right) \cdot P(C)}{P\left(\frac{\bar{L}}{C}\right) \cdot P(C) + P\left(\frac{\bar{L}}{S}\right) \cdot P(S) + P\left(\frac{\bar{L}}{B}\right) \cdot P(B) + P\left(\frac{\bar{L}}{T}\right) \cdot P(T)} \end{aligned}$$

$$= \frac{\frac{7}{9} \times \frac{1}{7}}{\frac{7}{9} \times \frac{1}{7} + \frac{8}{9} \times \frac{3}{7} + \frac{5}{9} \times \frac{2}{7} + \frac{8}{9} \times \frac{1}{7}} = \frac{1}{7}$$

19. Let A_1 be the event exactly 4 white balls have been drawn. A_2 be the event exactly 5 white balls have been drawn.

A_3 be the event exactly 6 white balls have been drawn.

B be the event exactly 1 white ball is drawn from two draws. Then,

$$P(B) = P\left(\frac{B}{A_1}\right)P(A_1) + P\left(\frac{B}{A_2}\right)P(A_2) + P\left(\frac{B}{A_3}\right)P(A_3)$$

But $P\left(\frac{B}{A_3}\right) = 0$

[since, there are only 6 white balls in the bag]

$$\begin{aligned} \therefore P(B) &= P\left(\frac{B}{A_1}\right)P(A_1) + P\left(\frac{B}{A_2}\right)P(A_2) \\ &= \frac{{}^{12}C_2 \cdot {}^6C_4}{{}^{18}C_6} \cdot \frac{{}^{10}C_1 \cdot {}^2C_1}{{}^{12}C_2} + \frac{{}^{12}C_1 \cdot {}^6C_5}{{}^{18}C_6} \cdot \frac{{}^{11}C_1 \cdot {}^1C_1}{{}^{12}C_2} \end{aligned}$$

20. Let E be the event that coin tossed twice, shows head at first time and tail at second time and F be the event that coin drawn is fair.

$$\begin{aligned} P(F/E) &= \frac{P(E/F) \cdot P(F)}{P(E/F) \cdot P(F) + P(E/F') \cdot P(F')} \\ &= \frac{\frac{1}{2} \cdot \frac{1}{2} \cdot \frac{m}{N}}{\frac{1}{2} \cdot \frac{1}{2} \cdot \frac{m}{N} + \frac{2}{3} \cdot \frac{1}{3} \cdot \frac{N-m}{N}} \\ &= \frac{\frac{m}{4}}{\frac{m}{4} + \frac{2(N-m)}{9}} = \frac{9m}{8N+m} \end{aligned}$$

21. Let W_1 = ball drawn in the first draw is white.

B_1 = ball drawn in the first draw in black.

W_2 = ball drawn in the second draw is white.

Then, $P(W_2) = P(W_1)P(W_2/W_1) + P(B_1)P(W_2/B_1)$

$$\begin{aligned} &= \binom{m}{m+n} \binom{m+k}{m+n+k} + \binom{n}{m+n} \binom{m}{m+n+k} \\ &= \frac{m(m+k) + mn}{(m+n)(m+n+k)} = \frac{m(m+k+n)}{(m+n)(m+n+k)} = \frac{m}{m+n} \end{aligned}$$

22. The number of ways in which P_1, P_2, \dots, P_8 can be paired in four pairs

$$\begin{aligned} &= \frac{1}{4!} [({}^8C_2)({}^6C_2)({}^4C_2)({}^2C_2)] \\ &= \frac{1}{4!} \times \frac{8!}{2!6!} \times \frac{6!}{2!4!} \times \frac{4!}{2!2!} \times 1 \\ &= \frac{1}{4!} \times \frac{8 \times 7}{2! \times 1} \times \frac{6 \times 5}{2! \times 1} \times \frac{4 \times 3}{2! \times 1} \\ &= \frac{8 \times 7 \times 6 \times 5}{2 \cdot 2 \cdot 2 \cdot 2} = 105 \end{aligned}$$

Now, atleast two players certainly reach the second round between P_1, P_2 and P_3 and P_4 can reach in final if exactly two players play against each other between P_1, P_2, P_3 and remaining player will play against one of the players from P_5, P_6, P_7, P_8 and P_4 plays against one of the remaining three from $P_5 \dots P_8$.

This can be possible in

$${}^3C_2 \times {}^4C_1 \times {}^3C_1 = 3 \cdot 4 \cdot 3 = 36 \text{ ways}$$

\therefore Probability that P_4 and exactly one of $P_5 \dots P_8$ reach second round = $\frac{36}{105} = \frac{12}{35}$

If P_1, P_i, P_4 and P_j , where $i = 2$ or 3 and $j = 5$ or 6 or 7 reach the second round, then they can be paired in 2 pairs in $\frac{1}{2!} ({}^4C_2) ({}^2C_2) = 3$ ways. But P_4 will reach the final, if P_1 plays against P_i and P_4 plays against P_j .

130 Probability

Hence, the probability that P_4 will reach the final round from the second = $\frac{1}{3}$

\therefore Probability that P_4 will reach the final is $\frac{12}{35} \times \frac{1}{3} = \frac{4}{35}$.

- 23.** Let $q = 1 - p =$ probability of getting the tail. We have,
 $\alpha =$ probability of A getting the head on tossing firstly
 $= P(H_1 \text{ or } T_1T_2T_3H_4 \text{ or } T_1T_2T_3T_4T_5T_6H_7 \text{ or } \dots)$
 $= P(H) + P(H)P(T)^3 + P(H)P(T)^6 + \dots$
 $= \frac{P(H)}{1 - P(T)^3} = \frac{p}{1 - q^3}$

Also,

$\beta =$ probability of B getting the head on tossing secondly
 $= P(T_1H_2 \text{ or } T_1T_2T_3T_4H_5 \text{ or } T_1T_2T_3T_4T_5T_6T_7H_8 \text{ or } \dots)$
 $= P(H)[P(T) + P(H)P(T)^4 + P(H)P(T)^7 + \dots]$
 $= P(T)[P(H) + P(H)P(T)^3 + P(H)P(T)^6 + \dots]$
 $= q\alpha = (1 - p)\alpha = \frac{p(1 - p)}{1 - q^3}$

Again, we have

$$\begin{aligned} \alpha + \beta + \gamma &= 1 \\ \Rightarrow \gamma &= 1 - (\alpha + \beta) = 1 - \frac{p + p(1 - p)}{1 - q^3} \\ &= 1 - \frac{p + p(1 - p)}{1 - (1 - p)^3} \\ &= \frac{1 - (1 - p)^3 - p - p(1 - p)}{1 - (1 - p)^3} \\ \gamma &= \frac{1 - (1 - p)^3 - 2p + p^2}{1 - (1 - p)^3} = \frac{p - 2p^2 + p^3}{1 - (1 - p)^3} \end{aligned}$$

Also, $\alpha = \frac{p}{1 - (1 - p)^3}, \beta = \frac{p(1 - p)}{1 - (1 - p)^3}$

- 24.** (i) Probability of S_1 to be among the eight winners
 $=$ (Probability of S_1 being a pair)
 \times (Probability of S_1 winning in the group)
 $= 1 \times \frac{1}{2} = \frac{1}{2}$ [since, S_1 is definitely in a group]

(ii) If S_1 and S_2 are in the same pair, then exactly one wins.

If S_1 and S_2 are in two pairs separately, then exactly one of S_1 and S_2 will be among the eight winners. If S_1 wins and S_2 loses or S_1 loses and S_2 wins.

Now, the probability of S_1, S_2 being in the same pair and one wins

$=$ (Probability of S_1, S_2 being the same pair)
 \times (Probability of anyone winning in the pair).
and the probability of S_1, S_2 being the same pair

$$= \frac{n(E)}{n(S)}$$

where, $n(E) =$ the number of ways in which 16 persons can be divided in 8 pairs.

$$\therefore n(E) = \frac{(14)!}{(2!)^7 \cdot 7!} \text{ and } n(S) = \frac{(16)!}{(2!)^8 \cdot 8!}$$

$$\therefore \text{Probability of } S_1 \text{ and } S_2 \text{ being in the same pair} = \frac{(14)! \cdot (2!)^8 \cdot 8!}{(2!)^7 \cdot 7! \cdot (16)!} = \frac{1}{15}$$

The probability of any one winning in the pairs of $S_1, S_2 = P(\text{certain event}) = 1$

\therefore The pairs of S_1, S_2 being in two pairs separately and S_1 wins, S_2 loses + The probability of S_1, S_2 being in two pairs separately and S_1 loses, S_2 wins.

$$\begin{aligned} &= \left[1 - \frac{(14)!}{(2!)^7 \cdot 7!} \right] \times \frac{1}{2} \times \frac{1}{2} + \left[1 - \frac{(14)!}{(2!)^8 \cdot 8!} \right] \times \frac{1}{2} \times \frac{1}{2} \\ &= \frac{1}{2} \times \frac{14 \times (14)!}{15 \times (14)!} = \frac{7}{15} \end{aligned}$$

$$\therefore \text{Required probability} = \frac{1}{15} + \frac{7}{15} = \frac{8}{15}$$

- 25.** Let E_1, E_2, E_3 and A be the events defined as

$E_1 =$ the examinee guesses the answer

$E_2 =$ the examinee copies the answer

$E_3 =$ the examinee knows the answer

and $A =$ the examinee answer correctly

We have, $P(E_1) = \frac{1}{3}, P(E_2) = \frac{1}{6}$

Since, E_1, E_2, E_3 are mutually exclusive and exhaustive events.

$$\therefore P(E_1) + P(E_2) + P(E_3) = 1 \Rightarrow P(E_3) = 1 - \frac{1}{3} - \frac{1}{6} = \frac{1}{2}$$

If E_1 has already occurred, then the examinee guesses. Since, there are four choices out of which only one is correct, therefore the probability that he answer correctly given that he has made a guess is $1/4$.

i.e. $P(A/E_1) = \frac{1}{4}$

It is given that, $P(A/E_2) = \frac{1}{8}$

and $P(A/E_3) =$ probability that he answer correctly given that he know the answer = 1

By Baye's theorem, we have

$$P(E_3/A) = \frac{P(E_3) \cdot P(A/E_3)}{\left[P(E_1) \cdot P(A/E_1) + P(E_2) \cdot P(A/E_2) + P(E_3) \cdot P(A/E_3) \right]}$$

$$\therefore P(E_3/A) = \frac{\frac{1}{2} \times 1}{\left(\frac{1}{3} \times \frac{1}{4} \right) + \left(\frac{1}{6} \times \frac{1}{8} \right) + \left(\frac{1}{2} \times 1 \right)} = \frac{24}{29}$$

- 26.** Let $B_i =$ i th ball drawn is black.
 $W_i =$ i th ball drawn is white, where $i = 1, 2$
and $A =$ third ball drawn is black.

We observe that the black ball can be drawn in the third draw in one of the following mutually exclusive ways.

(i) Both first and second balls drawn are white and third ball drawn is black.

i.e. $(W_1 \cap W_2) \cap A$

(ii) Both first and second balls are black and third ball drawn is black.

i.e. $(B_1 \cap B_2) \cap A$

(iii) The first ball drawn is white, the second ball drawn is black and the third ball drawn is black.

i.e. $(W_1 \cap B_2) \cap A$

(iv) The first ball drawn is black, the second ball drawn is white and the third ball drawn is black.

i.e. $(B_1 \cap W_2) \cap A$

$$\begin{aligned} \therefore P(A) &= P\{(W_1 \cap W_2) \cap A\} \cup \{(B_1 \cap B_2) \cap A\} \\ &\quad \cup \{(W_1 \cap B_2) \cap A\} \cup \{(B_1 \cap W_2) \cap A\} \\ &= P\{(W_1 \cap W_2) \cap A\} + P\{(B_1 \cap B_2) \cap A\} \\ &\quad + P\{(W_1 \cap B_2) \cap A\} + P\{(B_1 \cap W_2) \cap A\} \\ &= P(W_1 \cap W_2) \cdot P(A / (W_1 \cap W_2)) + P(B_1 \cap B_2) \\ \therefore P(A / (B_1 \cap B_2)) &+ P(W_1 \cap B_2) \cdot P(A / (W_1 \cap B_2)) \\ &\quad + P(B_1 \cap W_2) \cdot P(A / (B_1 \cap W_2)) \\ &= \left(\frac{2}{4} \times \frac{1}{3}\right) \times 1 + \left(\frac{2}{4} \times \frac{3}{5}\right) \times \frac{4}{6} \\ &\quad + \left(\frac{2}{4} \times \frac{2}{3}\right) \times \frac{3}{4} + \left(\frac{2}{4} \times \frac{2}{5}\right) \times \frac{3}{4} \\ &= \frac{1}{6} + \frac{1}{5} + \frac{1}{4} + \frac{3}{20} = \frac{23}{30} \end{aligned}$$

27. The testing procedure may terminate at the twelfth testing in two mutually exclusive ways.

I : When lot contains 2 defective articles.

II : When lot contains 3 defective articles.

Let A = testing procedure ends at twelfth testing

A_1 = lot contains 2 defective articles

A_2 = lot contains 3 defective articles

\therefore Required probability

$$= P(A_1) \cdot P(A / A_1) + P(A_2) \cdot P(A / A_2)$$

Here, $P(A / A_1)$ = probability that first 11 draws contain 10 non-defective and one-defective and twelfth draw contains a defective article.

$$= \frac{{}^{18}C_{10} \times {}^2C_1}{20C_{11}} \times \frac{1}{9} \quad \dots(i)$$

$P(A / A_2)$ = probability that first 11 draws contains 9 non-defective and 2-defective articles and twelfth draw contains defective = $\frac{{}^{17}C_9 \times {}^3C_2}{20C_{11}} \times \frac{1}{9} \quad \dots(ii)$

\therefore Required probability

$$\begin{aligned} &= (0.4)P(A / A_1) + 0.6P(A / A_2) \\ &= \frac{0.4 \times {}^{18}C_{10} \times {}^2C_1}{20C_{11}} \times \frac{1}{9} + \frac{0.6 \times {}^{17}C_9 \times {}^3C_2}{20C_{11}} \times \frac{1}{9} = \frac{99}{1900} \end{aligned}$$

Topic 5 Probability Distribution and Binomial Distribution

1. It is given that α is the number of heads that appear when C_1 is tossed twice, the probability distribution of random variable α is

α	0	1	2
$P(\alpha)$	$\left(\frac{1}{3}\right)^2$	$2\left(\frac{2}{3}\right)\left(\frac{1}{3}\right)$	$\left(\frac{2}{3}\right)^2$

Similarly, it is given that β is the number of heads that appear when C_2 is tossed twice, so probability distribution of random variable β is

β	0	1	2
$P(\beta)$	$\left(\frac{2}{3}\right)^2$	$\frac{4}{9}$	$\frac{1}{9}$

Now, as the roots of quadratic polynomial $x^2 - \alpha x + \beta$ are real and equal, so $D = \alpha^2 - 4\beta = 0$ and it is possible if $(\alpha, \beta) = (0, 0)$

or $(2, 1)$

$$\begin{aligned} \therefore \text{Required probability} &= \left(\frac{1}{3}\right)^2 \left(\frac{2}{3}\right)^2 + \left(\frac{2}{3}\right)^2 \left(\frac{4}{9}\right) \\ &= \frac{4}{81} + \frac{16}{81} = \frac{20}{81} \end{aligned}$$

2. As we know that the probability of show up a three or a five on a throw of a dice is

$$P(E) = \frac{2}{6} = \frac{1}{3}$$

$$\therefore P(\bar{E}) = \frac{2}{3}$$

Now, as four fair dice are thrown independently 27 times, so probability of getting at least two 3's or 5's in one trial

$$\begin{aligned} p &= {}^4C_2 \left(\frac{1}{3}\right)^2 \left(\frac{2}{3}\right)^2 + {}^4C_3 \left(\frac{1}{3}\right)^3 \left(\frac{2}{3}\right) + {}^4C_4 \left(\frac{1}{3}\right)^4 \\ &= 6 \left(\frac{4}{3^4}\right) + 4 \frac{2}{3^4} + \frac{1}{3^4} \\ &= \frac{24 + 8 + 1}{3^4} = \frac{33}{3^4} = \frac{11}{27} \end{aligned}$$

Therefore, the expected number of times in 27 trials = $27p = 11$

3. It is given that out of the five machines in a workshop, the probability of any one of them to be out of service on a day is $\frac{1}{4}$.

So, the probability that at most two machines will be out of service on the same day

= probability that no machine is out of service + probability that exactly one machine is out of service + probability that exactly two of machines are out of service

$$\left(1 - \frac{1}{4}\right)^5 + {}^5C_1 \frac{1}{4} \left(1 - \frac{1}{4}\right)^4 + {}^5C_2 \left(\frac{1}{4}\right)^2 \left(1 - \frac{1}{4}\right)^3 = \left(\frac{3}{4}\right)^5 k$$

(given)

132 Probability

$$\begin{aligned} \Rightarrow \left(\frac{3}{4}\right)^5 + \frac{5}{4}\left(\frac{3}{4}\right)^4 + 10\frac{3^3}{4^3} &= \left(\frac{3}{4}\right)^k \\ \Rightarrow k &= \left(\frac{3}{4}\right)^2 + \frac{15}{4^2} + \frac{10}{4^2} \\ &= \frac{9+15+10}{16} = \frac{34}{16} \\ \Rightarrow k &= \frac{17}{8} \end{aligned}$$

4. Given that, there are 50 problems to solve in an admission test and probability that the candidate can solve any problem is $\frac{4}{5} = q$ (say). So, probability that the candidate cannot solve a problem is $p = 1 - q = 1 - \frac{4}{5} = \frac{1}{5}$.

Now, let X be a random variable which denotes the number of problems that the candidate is unable to solve. Then, X follows binomial distribution with parameters $n = 50$ and $p = \frac{1}{5}$.

Now, according to binomial probability distribution concept

$$P(X = r) = {}^{50}C_r \left(\frac{1}{5}\right)^r \left(\frac{4}{5}\right)^{50-r}, \quad r = 0, 1, \dots, 50$$

\therefore Required probability

$$\begin{aligned} &= P(X < 2) = P(X = 0) + P(X = 1) \\ &= {}^{50}C_0 \left(\frac{1}{5}\right)^0 + {}^{50}C_1 \frac{4^{49}}{5^{50}} = \left(\frac{4}{5}\right)^{49} \left(\frac{4}{5} + \frac{50}{5}\right) = \frac{54}{5} \left(\frac{4}{5}\right)^{49} \end{aligned}$$

5. Let for the given random variable 'X' the binomial probability distribution have n -number of independent trials and probability of success and failure are p and q respectively. According to the question, Mean = $np = 8$ and variance = $npq = 4$

$$\therefore q = \frac{1}{2} \Rightarrow p = 1 - q = \frac{1}{2}$$

$$\text{Now, } n \times \frac{1}{2} = 8 \Rightarrow n = 16$$

$$P(X = r) = {}^{16}C_r \left(\frac{1}{2}\right)^{16}$$

$$\begin{aligned} \therefore P(X \leq 2) &= P(X = 0) + P(X = 1) + P(X = 2) \\ &= {}^{16}C_0 \left(\frac{1}{2}\right)^{16} + {}^{16}C_1 \left(\frac{1}{2}\right)^{16} + {}^{16}C_2 \left(\frac{1}{2}\right)^{16} \\ &= \frac{1+16+120}{2^{16}} = \frac{137}{2^{16}} = \frac{k}{2^{16}} \quad (\text{given}) \end{aligned}$$

$$\Rightarrow k = 137$$

6. As we know probability of getting a head on a toss of a fair coin is $P(H) = \frac{1}{2} = p$ (let)

Now, let n be the minimum numbers of toss required to get at least one head, then required probability = $1 - (\text{probability that on all 'n' toss we are getting tail})$

$$= 1 - \left(\frac{1}{2}\right)^n \quad \left[\because P(\text{tail}) = P(\text{Head}) = \frac{1}{2} \right]$$

According to the question,

$$1 - \left(\frac{1}{2}\right)^n > \frac{99}{100} \Rightarrow \left(\frac{1}{2}\right)^n < 1 - \frac{99}{100}$$

$$\Rightarrow \left(\frac{1}{2}\right)^n < \frac{1}{100} \Rightarrow 2^n > 100$$

$$\Rightarrow n = 7 \quad [\text{for minimum}]$$

7. The required probability of observing atleast one head

$$= 1 - P(\text{no head})$$

$$= 1 - \frac{1}{2^n} \quad [\text{let number of toss are } n]$$

$$\left[\because P(\text{Head}) = P(\text{Tail}) = \frac{1}{2} \right]$$

$$\text{According to the question, } 1 - \frac{1}{2^n} \geq \frac{90}{100}$$

$$\Rightarrow \frac{1}{2^n} \leq \frac{1}{10} \Rightarrow 2^n \geq 10 \Rightarrow n \geq 4$$

So, minimum number of times one has to toss a fair coin so that the probability of observing atleast one head is atleast 90% is 4.

8. Let p and q represents the probability of success and failure in a trial respectively. Then,

$$p = P(5 \text{ or } 6) = \frac{2}{6} = \frac{1}{3} \text{ and } q = 1 - p = \frac{4}{6} = \frac{2}{3}$$

Now, as the man decides to throw the die either till he gets a five or a six or to a maximum of three throws, so he can get the success in first, second and third throw or not get the success in any of the three throws.

So, the expected gain/loss (in ₹)

$$\begin{aligned} &= (p \times 100) + qp(-50 + 100) \\ &\quad + q^2p(-50 - 50 + 100) + q^3(-50 - 50 - 50) \\ &= \left(\frac{1}{3} \times 100\right) + \left(\frac{2}{3} \times \frac{1}{3}\right)(50) + \left(\frac{2}{3}\right)^2 \left(\frac{1}{3}\right)(0) + \left(\frac{2}{3}\right)^3 (-150) \\ &= \frac{100}{3} + \frac{100}{9} + 0 - \frac{1200}{27} \\ &= \frac{900 + 300 - 1200}{27} = \frac{1200 - 1200}{27} = 0 \end{aligned}$$

9. The probability of hitting a target at least once = $1 - (\text{probability of not hitting the target in any trial})$ = $1 - {}^nC_0 p^0 q^n$

where n is the number of independent trials and p and q are the probability of success and failure respectively.

[by using binomial distribution]

$$\text{Here, } p = \frac{1}{3} \text{ and } q = 1 - p = 1 - \frac{1}{3} = \frac{2}{3}$$

$$\text{According to the question, } 1 - {}^nC_0 \left(\frac{1}{3}\right)^0 \left(\frac{2}{3}\right)^n > \frac{5}{6}$$

$$\Rightarrow \left(\frac{2}{3}\right)^n < 1 - \frac{5}{6} \Rightarrow \left(\frac{2}{3}\right)^n < \frac{1}{6}$$

Clearly, minimum value of n is 5.

10. Let p = probability of getting an ace in a draw = probability of success

and q = probability of not getting an ace in a draw = probability of failure

Then, $p = \frac{4}{52} = \frac{1}{13}$

and $q = 1 - p = 1 - \frac{1}{13} = \frac{12}{13}$

Here, number of trials, $n = 2$

Clearly, X follows binomial distribution with parameter $n = 2$ and $p = \frac{1}{13}$.

Now, $P(X = x) = {}^2C_x \left(\frac{1}{13}\right)^x \left(\frac{12}{13}\right)^{2-x}$, $x = 0, 1, 2$

$$\begin{aligned} \therefore P(X = 1) + P(X = 2) &= {}^2C_1 \left(\frac{1}{13}\right)^1 \left(\frac{12}{13}\right) + {}^2C_2 \left(\frac{1}{13}\right)^2 \left(\frac{12}{13}\right)^0 \\ &= 2 \left(\frac{12}{169}\right) + \frac{1}{169} \\ &= \frac{24}{169} + \frac{1}{169} = \frac{25}{169} \end{aligned}$$

11. Given box contains 15 green and 10 yellow balls.

\therefore Total number of balls = $15 + 10 = 25$

$P(\text{green balls}) = \frac{15}{25} = \frac{3}{5} = p = \text{Probability of success}$

$P(\text{yellow balls}) = \frac{10}{25} = \frac{2}{5} = q = \text{Probability of unsuccess}$

and $n = 10 = \text{Number of trials.}$

\therefore Variance = $npq = 10 \times \frac{3}{5} \times \frac{2}{5} = \frac{12}{5}$

12. Probability of guessing a correct answer, $p = \frac{1}{3}$ and probability of guessing a wrong answer, $q = 2/3$

\therefore The probability of guessing a 4 or more correct answers = ${}^5C_4 \left(\frac{1}{3}\right)^4 \cdot \frac{2}{3} + {}^5C_5 \left(\frac{1}{3}\right)^5 = 5 \cdot \frac{2}{3^5} + \frac{1}{3^5} = \frac{11}{3^5}$

13. India play 4 matches and getting at least 7 points. It can only be possible in $WWWD$ or $WWWW$ position, where W represents two points and D represents one point.

Therefore, the probability of the required event

$$\begin{aligned} &= {}^4C_3 (0.05) (0.5)^3 + {}^4C_4 (0.5)^4 \\ &= [4(0.05) + 0.5] (0.5)^3 \\ &= 0.0875 \end{aligned}$$

14. Let X be the number of coins showing heads. Let X be a binomial variate with parameters $n = 100$ and p .

Since, $P(X = 50) = P(X = 51)$

$$\begin{aligned} \Rightarrow {}^{100}C_{50} p^{50} (1-p)^{50} &= {}^{100}C_{51} (p)^{51} (1-p)^{49} \\ \Rightarrow \frac{(100)!}{(50!) (50!)} \cdot \frac{(51!) \times (49!)}{100!} &= \frac{p}{1-p} \Rightarrow \frac{p}{1-p} = \frac{51}{50} \\ \Rightarrow p &= \frac{51}{101} \end{aligned}$$

15. For Binomial distribution, mean = np

and variance = npq

$\therefore np = 2$ and $npq = 1$ [given]

$\Rightarrow q = 1/2$ and $p + q = 1$

$\Rightarrow p = 1/2$

$\therefore n = 4, p = q = 1/2$

Now, $P(X > 1) = 1 - \{P(X = 0) + P(X = 1)\}$

$$\begin{aligned} &= 1 - {}^4C_0 \left(\frac{1}{2}\right)^0 \left(\frac{1}{2}\right)^4 - {}^4C_1 \left(\frac{1}{2}\right)^1 \left(\frac{1}{2}\right)^3 \\ &= 1 - \frac{1}{16} - \frac{4}{16} = \frac{11}{16} \end{aligned}$$

16. Probability (face 1) = $\frac{0.1}{0.1 + 0.32} = \frac{0.1}{0.42} = \frac{5}{21}$

17. Let E be the event that product of the two digits is 18, therefore required numbers are 29, 36, 63 and 92.

Hence, $p = P(E) = \frac{4}{100}$

and probability of non-occurrence of E is

$$q = 1 - P(E) = 1 - \frac{4}{100} = \frac{96}{100}$$

Out of the four numbers selected, the probability that the event E occurs atleast 3 times, is given as

$$\begin{aligned} P &= {}^4C_3 p^3 q + {}^4C_4 p^4 \\ &= 4 \left(\frac{4}{100}\right)^3 \left(\frac{96}{100}\right) + \left(\frac{4}{100}\right)^4 = \frac{97}{25^4} \end{aligned}$$

18. Since, set A contains n elements. So, it has 2^n subsets.

\therefore Set P can be chosen in 2^n ways, similarly set Q can be chosen in 2^n ways.

$\therefore P$ and Q can be chosen in $(2^n)(2^n) = 4^n$ ways.

Suppose, P contains r elements, where r varies from 0 to n . Then, P can be chosen in ${}^n C_r$ ways, for 0 to be disjoint from A , it should be chosen from the set of all subsets of set consisting of remaining $(n - r)$ elements. This can be done in 2^{n-r} ways.

$\therefore P$ and Q can be chosen in ${}^n C_r \cdot 2^{n-r}$ ways.

But, r can vary from 0 to n .

\therefore Total number of disjoint sets P and Q

$$= \sum_{r=0}^n {}^n C_r 2^{n-r} = (1 + 2)^n = 3^n$$

Hence, required probability = $\frac{3^n}{4^n} = \left(\frac{3}{4}\right)^n$

19. **Case I** When A plays 3 games against B .

In this case, we have $n = 3, p = 0.4$ and $q = 0.6$

Let X denote the number of wins. Then,

$$P(X = r) = {}^3C_r (0.4)^r (0.6)^{3-r}; r = 0, 1, 2, 3$$

$\therefore P_1 = \text{probability of winning the best of 3 games}$

$$\begin{aligned} &= P(X \geq 2) \\ &= P(X = 2) + P(X = 3) \\ &= {}^3C_2 (0.4)^2 (0.6)^1 + {}^3C_3 (0.4)^3 (0.6)^0 \\ &= 0.288 + 0.064 = 0.352 \end{aligned}$$

Case II When A plays 5 games against B .

In this case, we have

$$n = 5, p = 0.4 \quad \text{and} \quad q = 0.6$$

134 Probability

Let X denotes the number of wins in 5 games.

Then,

$$P(X = r) = {}^5C_r (0.4)^r (0.6)^{5-r}, \text{ where } r = 0, 1, 2, \dots, 5$$

$\therefore P_2 =$ probability of winning the best of 5 games

$$\begin{aligned} &= P(X \geq 3) \\ &= P(X = 3) + P(X = 4) + P(X = 5) \\ &= {}^5C_3 (0.4)^3 (0.6)^2 + {}^5C_4 (0.4)^4 (0.6) + {}^5C_5 (0.4)^5 (0.6)^0 \\ &= 0.2304 + 0.0768 + 0.1024 = 0.31744 \end{aligned}$$

Clearly, $P_1 > P_2$. Therefore, first option i.e. 'best of 3 games' has higher probability of winning the match.

- 20.** The man will be one step away from the starting point, if

(i) either he is one step ahead or (ii) one step behind the starting point.

The man will be one step ahead at the end of eleven steps, if he moves six steps forward and five steps backward. The probability of this event is ${}^{11}C_6 (0.4)^6 (0.6)^5$.

The man will be one step behind at the end of eleven steps, if he moves six steps backward and five steps forward. The probability of this event is ${}^{11}C_6 (0.6)^6 (0.4)^5$.

\therefore Required probability

$$= {}^{11}C_6 (0.4)^6 (0.6)^5 + {}^{11}C_6 (0.6)^6 (0.4)^5 = {}^{11}C_6 (0.24)^5$$

- 21.** Let an event E of sum of outputs are perfect square (i.e., 4 or 9), so

$$E = \{(1, 3), (2, 2), (3, 1), (3, 6), (4, 5), (5, 4), (6, 3)\}$$

and an event F of sum of outputs are prime numbers

(i.e., 2, 3, 5, 7, 11) so

$$F = \{(1, 1), (1, 2), (2, 1), (1, 4), (2, 3), (3, 2), (4, 1), (1, 6), (2, 5), (3, 4), (4, 3), (5, 2), (6, 1), (5, 6), (6, 5)\}$$

and event T of sum of outputs are odd numbers

(i.e., 3, 5, 7, 9, 11)

$$T = \{(1, 2), (2, 1), (1, 4), (2, 3), (3, 2), (4, 1), (1, 6), (2, 5), (3, 4), (4, 3), (5, 2), (6, 1), (3, 6), (4, 5), (5, 4), (6, 3), (5, 6), (6, 5)\}$$

Now, required probability $p = P(T/E)$

$$= \frac{P(T \cap E)}{P(E)}$$

where, $P(T \cap E)$ = probability of occurring perfect square odd number before prime

$$\begin{aligned} &= \left(\frac{4}{36}\right) + \left(\frac{14}{36}\right)\left(\frac{4}{36}\right) + \left(\frac{14}{36}\right)^2\left(\frac{4}{36}\right) + \dots \infty \\ &= \frac{\frac{4}{36}}{1 - \frac{14}{36}} = \frac{4}{22} = \frac{2}{11} \end{aligned}$$

and $P(E)$ = probability of occurring perfect square before prime

$$\begin{aligned} &= \left(\frac{7}{36}\right) + \left(\frac{14}{36}\right)\left(\frac{7}{36}\right) + \left(\frac{14}{36}\right)^2\left(\frac{7}{36}\right) + \dots \infty \\ &= \frac{\frac{7}{36}}{1 - \frac{14}{36}} = \frac{7}{22} \end{aligned}$$

$$\therefore P(T/E) = \frac{\frac{2}{11}}{\frac{7}{22}} = \frac{4}{7} = p$$

$$\Rightarrow 14p = 8$$

- 22.** It is given that the probability, a missile hits a target successfully $p = \frac{3}{4}$, so the probability to not hits the target is $q = \frac{1}{4}$.

And it is also given that to destroy the target completely, at least three successful hits are required.

Now, according to the question, let the minimum number of missiles required to fired is n , so

$${}^nC_3 p^3 q^{n-3} + {}^nC_4 p^4 q^{n-4} + \dots + {}^nC_n p^n \geq 0.95$$

$$\Rightarrow 1 - \left\{ {}^nC_0 \left(\frac{1}{4}\right)^n + {}^nC_1 \left(\frac{3}{4}\right) \left(\frac{1}{4}\right)^{n-1} + {}^nC_2 \left(\frac{3}{4}\right)^2 \left(\frac{1}{4}\right)^{n-2} \right\} \geq 0.95$$

$$\Rightarrow 1 - \frac{95}{100} \geq \frac{1}{4^n} + \frac{3n}{4^n} + \frac{n(n-1)}{2} \frac{9}{4^n}$$

$$\Rightarrow \frac{4^n}{20} \geq \frac{2 + 6n + 9n^2 - 9n}{2}$$

$$\Rightarrow 10(9n^2 - 3n + 2) \leq 4^n$$

Now, at $n = 3$, LHS = 720, RHS = 64

at $n = 4$, LHS = 1340, RHS = 256

at $n = 5$, LHS = 2120, RHS = 1024

at $n = 6$, LHS = 3080, RHS = 4096

Hence, $n = 6$ missiles should be fired.

- 23.** Using Binomial distribution,

$$P(X \geq 2) = 1 - P(X = 0) - P(X = 1)$$

$$= 1 - \left(\frac{1}{2}\right)^n - \left[{}^nC_1 \cdot \left(\frac{1}{2}\right) \cdot \left(\frac{1}{2}\right)^{n-1} \right]$$

$$= 1 - \frac{1}{2^n} - {}^nC_1 \cdot \frac{1}{2^n} = 1 - \left(\frac{1+n}{2^n}\right)$$

Given, $P(X \geq 2) \geq 0.96$

$$\therefore 1 - \frac{(n+1)}{2^n} \geq \frac{24}{25} \Rightarrow \frac{n+1}{2^n} \leq \frac{1}{25} \Rightarrow n = 8$$

7

Matrices and Determinants

Topic 1 Types of Matrices, Addition, Subtraction, Multiplication and Transpose of a Matrix

Objective Questions I (Only one correct option)

1. If A is a symmetric matrix and B is a skew-symmetric matrix such that $A + B = \begin{bmatrix} 2 & 3 \\ 5 & -1 \end{bmatrix}$, then AB is equal to

(2019 Main, 12 April I)

- (a) $\begin{bmatrix} -4 & -2 \\ -1 & 4 \end{bmatrix}$ (b) $\begin{bmatrix} 4 & -2 \\ -1 & -4 \end{bmatrix}$
 (c) $\begin{bmatrix} 4 & -2 \\ 1 & -4 \end{bmatrix}$ (d) $\begin{bmatrix} -4 & 2 \\ 1 & 4 \end{bmatrix}$

2. The total number of matrices $A = \begin{bmatrix} 0 & 2y & 1 \\ 2x & y & -1 \\ 2x & -y & 1 \end{bmatrix}$,

($x, y \in R, x \neq y$) for which $A^T A = 3I_3$ is

(2019 Main, 9 April II)

- (a) 2 (b) 4
 (c) 3 (d) 6

3. Let $A = \begin{bmatrix} \cos \alpha & -\sin \alpha \\ \sin \alpha & \cos \alpha \end{bmatrix}$, ($\alpha \in R$) such that $A^{32} = \begin{bmatrix} 0 & -1 \\ 1 & 0 \end{bmatrix}$.

Then, a value of α is

(2019 Main, 8 April I)

- (a) $\frac{\pi}{32}$ (b) 0 (c) $\frac{\pi}{64}$ (d) $\frac{\pi}{16}$

4. Let $P = \begin{bmatrix} 1 & 0 & 0 \\ 3 & 1 & 0 \\ 9 & 3 & 1 \end{bmatrix}$ and $Q = [q_{ij}]$ be two 3×3 matrices such

that $Q - P^5 = I_3$. Then, $\frac{q_{21} + q_{31}}{q_{32}}$ is equal to

(2019 Main, 12 Jan I)

- (a) 10 (b) 135
 (c) 9 (d) 15

5. Let $A = \begin{bmatrix} 0 & 2q & r \\ p & q & -r \\ p & -q & r \end{bmatrix}$. If $AA^T = I_3$, then $|p|$ is

(2019 Main, 11 Jan I)

- (a) $\frac{1}{\sqrt{5}}$ (b) $\frac{1}{\sqrt{2}}$ (c) $\frac{1}{\sqrt{3}}$ (d) $\frac{1}{\sqrt{6}}$

6. Let $P = \begin{bmatrix} 1 & 0 & 0 \\ 4 & 1 & 0 \\ 16 & 4 & 1 \end{bmatrix}$ and I be the identity matrix of order

3. If $Q = [q_{ij}]$ is a matrix, such that $P^{50} - Q = I$, then $\frac{q_{31} + q_{32}}{q_{21}}$ equals

(2016 Adv.)

- (a) 52 (b) 103
 (c) 201 (d) 205

7. If $A = \begin{bmatrix} 1 & 2 & 2 \\ 2 & 1 & -2 \\ c & 2 & b \end{bmatrix}$ is a matrix satisfying the equation

$AA^T = 9I$, where, I is 3×3 identity matrix, then the ordered pair (a, b) is equal to

(2015 Main)

- (a) (2, -1) (b) (-2, 1)
 (c) (2, 1) (d) (-2, -1)

8. If $P = \begin{bmatrix} \sqrt{3}/2 & 1/2 \\ -1/2 & \sqrt{3}/2 \end{bmatrix}$, $A = \begin{bmatrix} 1 & 1 \\ 0 & 1 \end{bmatrix}$ and $Q = PAP^T$, then $P^T Q^{2005} P$ is

(2005, 1M)

- (a) $\begin{bmatrix} 1 & 2005 \\ 0 & 1 \end{bmatrix}$ (b) $\begin{bmatrix} 1 & 2005 \\ 2005 & 1 \end{bmatrix}$
 (c) $\begin{bmatrix} 1 & 0 \\ 2005 & 1 \end{bmatrix}$ (d) $\begin{bmatrix} 1 & 0 \\ 0 & 1 \end{bmatrix}$

9. If $A = \begin{bmatrix} \alpha & 0 \\ 1 & 1 \end{bmatrix}$ and $B = \begin{bmatrix} 1 & 0 \\ 5 & 1 \end{bmatrix}$, then value of α for which $A^2 = B$, is

(2003, 1M)

- (a) 1 (b) -1
 (c) 4 (d) no real values

10. If A and B are square matrices of equal degree, then which one is correct among the following? (1995, 2M)

- (a) $A + B = B + A$
 (b) $A + B = A - B$
 (c) $A - B = B - A$
 (d) $AB = BA$

136 Matrices and Determinants

Objective Questions II

One or more than one correct option)

11. Let $P_1 = I = \begin{bmatrix} 1 & 0 & 0 \\ 0 & 1 & 0 \\ 0 & 0 & 1 \end{bmatrix}$, $P_2 = \begin{bmatrix} 1 & 0 & 0 \\ 0 & 0 & 1 \\ 0 & 1 & 0 \end{bmatrix}$,
 $P_3 = \begin{bmatrix} 0 & 1 & 0 \\ 1 & 0 & 0 \\ 0 & 0 & 1 \end{bmatrix}$, $P_4 = \begin{bmatrix} 0 & 1 & 0 \\ 0 & 0 & 1 \\ 1 & 0 & 0 \end{bmatrix}$,
 $P_5 = \begin{bmatrix} 0 & 0 & 1 \\ 1 & 0 & 0 \\ 0 & 1 & 0 \end{bmatrix}$, $P_6 = \begin{bmatrix} 0 & 0 & 1 \\ 0 & 1 & 0 \\ 1 & 0 & 0 \end{bmatrix}$
 and $X = \sum_{k=1}^6 P_k \begin{bmatrix} 2 & 1 & 3 \\ 1 & 0 & 2 \\ 3 & 2 & 1 \end{bmatrix} P_k^T$

where, P_k^T denotes the transpose of the matrix P_k . Then which of the following option is/are correct? (2019 Adv.)

- (a) X is a symmetric matrix
 (b) The sum of diagonal entries of X is 18
 (c) $X - 30I$ is an invertible matrix
 (d) If $X \begin{bmatrix} 1 \\ 1 \\ 1 \end{bmatrix} = \alpha \begin{bmatrix} 1 \\ 1 \\ 1 \end{bmatrix}$, then $\alpha = 30$

12. Let X and Y be two arbitrary, 3×3 , non-zero, skew-symmetric matrices and Z be an arbitrary, 3×3 , non-zero, symmetric matrix. Then, which of the following matrices is/are skew-symmetric? (2015 Adv.)

- (a) $Y^3 Z^4 - Z^4 Y^3$ (b) $X^{44} + Y^{44}$
 (c) $X^4 Z^3 - Z^3 X^4$ (d) $X^{23} + Y^{23}$

13. For 3×3 matrices M and N , which of the following statement(s) is/are not correct? (2013 Adv.)

- (a) $N^T M N$ is symmetric or skew-symmetric, according as M is symmetric or skew-symmetric
 (b) $MN - NM$ is symmetric for all symmetric matrices M and N
 (c) MN is symmetric for all symmetric matrices M and N
 (d) $(\text{adj } M)(\text{adj } N) = \text{adj}(MN)$ for all invertible matrices M and N

14. Let ω be a complex cube root of unity with $\omega \neq 0$ and $P = [p_{ij}]$ be an $n \times n$ matrix with $p_{ij} = \omega^{i+j}$. Then, $P^2 \neq 0$ when n is equal to (2013 Adv.)

- (a) 57 (b) 55
 (c) 58 (d) 56

Passage Based Problems

Passage I

Let a, b and c be three real numbers satisfying

$$[a \ b \ c] \begin{bmatrix} 1 & 9 & 7 \\ 8 & 2 & 7 \\ 7 & 3 & 7 \end{bmatrix} = [0 \ 0 \ 0] \quad \dots(i)$$

(2011)

15. If the point $P(a, b, c)$, with reference to Eq. (i), lies on the plane $2x + y + z = 1$, then the value of $7a + b + c$ is
 (a) 0 (b) 12 (c) 7 (d) 6

16. Let $b = 6$, with a and c satisfying Eq. (i). If α and β are the roots of the quadratic equation $ax^2 + bx + c = 0$, then $\sum_{n=0}^{\infty} \left(\frac{1}{\alpha} + \frac{1}{\beta}\right)^n$ is equal to
 (a) 6 (b) 7 (c) $\frac{6}{7}$ (d) ∞

17. Let ω be a solution of $x^3 - 1 = 0$ with $\text{Im}(\omega) > 0$. If $a = 2$ with b and c satisfying Eq. (i) then the value of $\frac{3}{\omega^a} + \frac{1}{\omega^b} + \frac{3}{\omega^c}$ is
 (a) -2 (b) 2
 (c) 3 (d) -3

Passage II

Let p be an odd prime number and T_p be the following set of 2×2 matrices

$$T_p = \left\{ A = \begin{bmatrix} a & b \\ c & a \end{bmatrix}; a, b, c \in \{0, 1, 2, \dots, p-1\} \right\} \quad (2010)$$

18. The number of A in T_p such that $\det(A)$ is not divisible by p , is

- (a) $2p^2$ (b) $p^3 - 5p$
 (c) $p^3 - 3p$ (d) $p^3 - p^2$

19. The number of A in T_p such that the trace of A is not divisible by p but $\det(A)$ is divisible by p is

- (a) $(p-1)(p^2 - p + 1)$ (b) $p^3 - (p-1)^2$
 (c) $(p-1)^2$ (d) $(p-1)(p^2 - 2)$

20. The number of A in T_p such that A is either symmetric or skew-symmetric or both and $\det(A)$ is divisible by p is

- (a) $(p-1)^2$ (b) $2(p-1)$
 (c) $(p-1)^2 + 1$ (d) $2p-1$

NOTE The trace of a matrix is the sum of its diagonal entries.

Analytical and Descriptive Questions

21. If matrix $A = \begin{bmatrix} a & b & c \\ b & c & a \\ c & a & b \end{bmatrix}$, where a, b, c are real positive numbers, $abc = 1$ and $A^T A = I$, then find the value of $a^3 + b^3 + c^3$. (2003, 2M)

Integer & Numerical Answer Type Questions

22. The trace of a square matrix is defined to be the sum of its diagonal entries. If A is a 2×2 matrix such that the trace of A is 3 and the trace of A^3 is -18, then the value of the determinant of A is (2020 Adv.)

23. Let $z = \frac{-1 + \sqrt{3}i}{2}$, where $i = \sqrt{-1}$, and $r, s \in \{1, 2, 3\}$. Let

$$P = \begin{bmatrix} (-z)^r & z^{2s} \\ z^{2s} & z^r \end{bmatrix} \text{ and } I \text{ be the identity matrix of order 2.}$$

Then, the total number of ordered pairs (r, s) for which $P^2 = -I$ is (2016 Adv.)

Topic 2 Properties of Determinants

Objective Questions I (Only one correct option)

1. If the minimum and the maximum values of the function $f: \left[\frac{\pi}{4}, \frac{\pi}{2}\right] \rightarrow \mathbb{R}$,

$$\text{defined by } f(\theta) = \begin{vmatrix} -\sin^2\theta & -1-\sin^2\theta & 1 \\ -\cos^2\theta & -1-\cos^2\theta & 1 \\ 12 & 10 & -2 \end{vmatrix} \text{ are } m \text{ and } M$$

respectively, then the ordered pair (m, M) is equal to
(2020 Main, 5 Sep I)

- (a) $(0, 2\sqrt{2})$ (b) $(-4, 4)$ (c) $(0, 4)$ (d) $(-4, 0)$
2. A value of $\theta \in (0, \pi/3)$, for which
- $$\begin{vmatrix} 1 + \cos^2\theta & \sin^2\theta & 4 \cos 6\theta \\ \cos^2\theta & 1 + \sin^2\theta & 4 \cos 6\theta \\ \cos^2\theta & \sin^2\theta & 1 + 4 \cos 6\theta \end{vmatrix} = 0, \text{ is}$$
- (2019 Main, 12 April II)
- (a) $\frac{\pi}{9}$ (b) $\frac{\pi}{18}$ (c) $\frac{7\pi}{24}$ (d) $\frac{7\pi}{36}$

3. The sum of the real roots of the equation
- $$\begin{vmatrix} x & -6 & -1 \\ 2 & -3x & x-3 \\ -3 & 2x & x+2 \end{vmatrix} = 0, \text{ is equal to}$$
- (2019 Main, 10 April II)
- (a) 0 (b) -4 (c) 6 (d) 1

4. If $\Delta_1 = \begin{vmatrix} x & \sin\theta & \cos\theta \\ -\sin\theta & -x & 1 \\ \cos\theta & 1 & x \end{vmatrix}$
- and $\Delta_2 = \begin{vmatrix} x & \sin 2\theta & \cos 2\theta \\ -\sin 2\theta & -x & 1 \\ \cos 2\theta & 1 & x \end{vmatrix}, x \neq 0,$
- then for all $\theta \in \left(0, \frac{\pi}{2}\right)$ (2019 Main, 10 April I)

- (a) $\Delta_1 + \Delta_2 = -2(x^3 + x - 1)$
 (b) $\Delta_1 - \Delta_2 = -2x^3$
 (c) $\Delta_1 + \Delta_2 = -2x^3$
 (d) $\Delta_1 - \Delta_2 = x(\cos 2\theta - \cos 4\theta)$

5. If $\begin{bmatrix} 1 & 1 \\ 0 & 1 \end{bmatrix} \cdot \begin{bmatrix} 1 & 2 \\ 0 & 1 \end{bmatrix} \cdot \begin{bmatrix} 1 & 3 \\ 0 & 1 \end{bmatrix} \cdots \begin{bmatrix} 1 & n-1 \\ 0 & 1 \end{bmatrix} = \begin{bmatrix} 1 & 78 \\ 0 & 1 \end{bmatrix}$, then the inverse of $\begin{bmatrix} 1 & n \\ 0 & 1 \end{bmatrix}$ is (2019 Main, 9 April I)
- (a) $\begin{bmatrix} 1 & 0 \\ 12 & 1 \end{bmatrix}$ (b) $\begin{bmatrix} 1 & -13 \\ 0 & 1 \end{bmatrix}$ (c) $\begin{bmatrix} 1 & 0 \\ 13 & 1 \end{bmatrix}$ (d) $\begin{bmatrix} 1 & -12 \\ 0 & 1 \end{bmatrix}$

6. Let α and β be the roots of the equation $x^2 + x + 1 = 0$. Then, for $y \neq 0$ in \mathbb{R} ,
- $$\begin{vmatrix} y+1 & \alpha & \beta \\ \alpha & y+\beta & 1 \\ \beta & 1 & y+\alpha \end{vmatrix} \text{ is equal to}$$
- (2019 Main, 9 April I)
- (a) $y(y^2 - 1)$ (b) $y(y^2 - 3)$
 (c) $y^3 - 1$ (d) y^3

7. Let the numbers 2, b , c be in an AP and $A = \begin{bmatrix} 1 & 1 & 1 \\ 2 & b & c \\ 4 & b^2 & c^2 \end{bmatrix}$.

If $\det(A) \in [2, 16]$, then c lies in the interval
(2019 Main, 8 April II)

- (a) $[3, 2 + 2^{3/4}]$ (b) $(2 + 2^{3/4}, 4)$
 (c) $[4, 6]$ (d) $[2, 3]$
8. If $A = \begin{bmatrix} 1 & \sin\theta & 1 \\ -\sin\theta & 1 & \sin\theta \\ -1 & -\sin\theta & 1 \end{bmatrix}$; then for all $\theta \in \left(\frac{3\pi}{4}, \frac{5\pi}{4}\right)$, $\det(A)$ lies in the interval (2019 Main, 12 Jan II)
- (a) $\left(\frac{3}{2}, 3\right]$ (b) $\left[\frac{5}{2}, 4\right)$ (c) $\left(0, \frac{3}{2}\right]$ (d) $\left(1, \frac{5}{2}\right]$

9. If $\begin{vmatrix} a-b-c & 2a & 2a \\ 2b & b-c-a & 2b \\ 2c & 2c & c-a-b \end{vmatrix}$
 $= (a+b+c)(x+a+b+c)^2, x \neq 0$ and $a+b+c \neq 0$, then x is equal to (2019 Main, 11 Jan II)
- (a) $-(a+b+c)$ (b) $-2(a+b+c)$
 (c) $2(a+b+c)$ (d) abc

10. Let $a_1, a_2, a_3, \dots, a_{10}$ be in GP with $a_i > 0$ for $i = 1, 2, \dots, 10$ and S be the set of pairs $(r, k), r, k \in \mathbb{N}$ (the set of natural numbers) for which

$$\begin{vmatrix} \log_e a_1^r a_2^k & \log_e a_2^r a_3^k & \log_e a_3^r a_4^k \\ \log_e a_4^r a_5^k & \log_e a_5^r a_6^k & \log_e a_6^r a_7^k \\ \log_e a_7^r a_8^k & \log_e a_8^r a_9^k & \log_e a_9^r a_{10}^k \end{vmatrix} = 0$$

Then, the number of elements in S , is (2019 Main, 10 Jan II)

(a) 4 (b) 2
 (c) 10 (d) infinitely many

11. Let $A = \begin{bmatrix} 2 & b & 1 \\ b & b^2 + 1 & b \\ 1 & b & 2 \end{bmatrix}$, where $b > 0$. Then, the minimum value of $\frac{\det(A)}{b}$ is (2019 Main, 10 Jan II)
- (a) $-\sqrt{3}$ (b) $-2\sqrt{3}$ (c) $2\sqrt{3}$ (d) $\sqrt{3}$

12. Let $d \in \mathbb{R}$, and
- $$A = \begin{bmatrix} -2 & 4+d & (\sin\theta) - 2 \\ 1 & (\sin\theta) + 2 & d \\ 5 & (2\sin\theta) - d & (-\sin\theta) + 2 + 2d \end{bmatrix}, \theta \in [0, 2\pi].$$
- If the minimum value of $\det(A)$ is 8, then a value of d is (2019 Main, 10 Jan I)
- (a) -5 (b) -7 (c) $2(\sqrt{2} + 1)$ (d) $2(\sqrt{2} + 2)$

13. If $\begin{vmatrix} x-4 & 2x & 2x \\ 2x & x-4 & 2x \\ 2x & 2x & x-4 \end{vmatrix} = (A+Bx)(x-A)^2$, then the ordered pair (A, B) is equal to (2018 Main)
- (a) $(-4, -5)$ (b) $(-4, 3)$ (c) $(-4, 5)$ (d) $(4, 5)$

138 Matrices and Determinants

14. Let ω be a complex number such that $2\omega + 1 = z$, where

$$z = \sqrt{-3}. \text{ If } \begin{vmatrix} 1 & 1 & 1 \\ 1 & -\omega^2 - 1 & \omega^2 \\ 1 & \omega^2 & \omega^7 \end{vmatrix} = 3k, \text{ then } k \text{ is equal to}$$

- (a) $-z$ (b) z (c) -1 (d) 1 (2017 Main)

15. If $\alpha, \beta \neq 0$ and $f(n) = \alpha^n + \beta^n$ and

$$\begin{vmatrix} 3 & 1 + f(1) & 1 + f(2) \\ 1 + f(1) & 1 + f(2) & 1 + f(3) \\ 1 + f(2) & 1 + f(3) & 1 + f(4) \end{vmatrix} = K(1 - \alpha)^2(1 - \beta)^2(\alpha - \beta)^2, \text{ then } K \text{ is equal to}$$

- (a) $\alpha\beta$ (b) $\frac{1}{\alpha\beta}$ (c) 1 (d) -1 (2014 Main)

16. Let $P = [a_{ij}]$ be a 3×3 matrix and let $Q = [b_{ij}]$, where $b_{ij} = 2^{i+j}a_{ij}$ for $1 \leq i, j \leq 3$. If the determinant of P is 2, then the determinant of the matrix Q is (2012)

- (a) 2^{10} (b) 2^{11} (c) 2^{12} (d) 2^{13}

17. If $A = \begin{bmatrix} \alpha & 2 \\ 2 & \alpha \end{bmatrix}$ and $|A^3| = 125$, then the value of α is (2004, 1M)

- (a) ± 1 (b) ± 2 (c) ± 3 (d) ± 5

18. The number of distinct real roots of (2001, 1M)

$$\begin{vmatrix} \sin x & \cos x & \cos x \\ \cos x & \sin x & \cos x \\ \cos x & \cos x & \sin x \end{vmatrix} = 0 \text{ in the interval } -\frac{\pi}{4} \leq x \leq \frac{\pi}{4} \text{ is}$$

- (a) 0 (b) 2
(c) 1 (d) 3

19. If $f(x) = \begin{vmatrix} 1 & x & x+1 \\ 2x & x(x-1) & (x+1)x \\ 3x(x-1) & x(x-1)(x-2) & (x+1)x(x-1) \end{vmatrix}$,

then $f(100)$ is equal to (1999, 2M)

- (a) 0 (b) 1
(c) 100 (d) -100

20. The parameter on which the value of the determinant

$$\begin{vmatrix} 1 & a & a^2 \\ \cos(p-d)x & \cos px & \cos(p+d)x \\ \sin(p-d)x & \sin px & \sin(p+d)x \end{vmatrix}$$

does not depend upon, is (1997, 2M)

- (a) a (b) p (c) d (d) x

21. The determinant $\begin{vmatrix} xp+y & x & y \\ yp+z & y & z \\ 0 & xp+y & yp+z \end{vmatrix} = 0$, if (1997C, 2M)

- (a) x, y, z are in AP (b) x, y, z are in GP
(c) x, y, z are in HP (d) xy, yz, zx are in AP

22. Consider the set A of all determinants of order 3 with entries 0 or 1 only. Let B be the subset of A consisting of all determinants with value 1. Let C be the subset of A consisting of all determinants with value -1 . Then,

- (a) C is empty (1981, 2M)
(b) B has as many elements as C
(c) $A = B \cup C$
(d) B has twice as many elements as C

Objective Questions II

(One or more than one correct option)

23. Which of the following is(are) NOT the square of a 3×3 matrix with real entries? (2017 Adv.)

(a) $\begin{bmatrix} 1 & 0 & 0 \\ 0 & 1 & 0 \\ 0 & 0 & -1 \end{bmatrix}$ (b) $\begin{bmatrix} 1 & 0 & 0 \\ 0 & -1 & 0 \\ 0 & 0 & -1 \end{bmatrix}$
(c) $\begin{bmatrix} -1 & 0 & 0 \\ 0 & -1 & 0 \\ 0 & 0 & -1 \end{bmatrix}$ (d) $\begin{bmatrix} 1 & 0 & 0 \\ 0 & 1 & 0 \\ 0 & 0 & 1 \end{bmatrix}$

24. Which of the following values of α satisfy the equation

$$\begin{vmatrix} (1+\alpha)^2 & (1+2\alpha)^2 & (1+3\alpha)^2 \\ (2+\alpha)^2 & (2+2\alpha)^2 & (2+3\alpha)^2 \\ (3+\alpha)^2 & (3+2\alpha)^2 & (3+3\alpha)^2 \end{vmatrix} = -648\alpha?$$

- (a) -4 (b) 9 (c) -9 (d) 4 (2015 Adv.)

25. Let M and N be two 3×3 matrices such that $MN = NM$. Further, if $M \neq N^2$ and $M^2 = N^4$, then (2014 Adv.)

- (a) determinant of $(M^2 + MN^2)$ is 0
(b) there is a 3×3 non-zero matrix U such that $(M^2 + MN^2)U$ is zero matrix
(c) determinant of $(M^2 + MN^2) \geq 1$
(d) for a 3×3 matrix U , if $(M^2 + MN^2)U$ equals the zero matrix, then U is the zero matrix

26. The determinant $\begin{vmatrix} a & b & a\alpha + b \\ b & c & b\alpha + c \\ a\alpha + b & b\alpha + c & 0 \end{vmatrix}$ is equal to zero, then (1986, 2M)

- (a) a, b, c are in AP
(b) a, b, c are in GP
(c) a, b, c are in HP
(d) $(x - \alpha)$ is a factor of $ax^2 + 2bx + c$

Integer & Numerical Answer Type Questions

27. Let P be a matrix of order 3×3 such that all the entries in P are from the set $\{-1, 0, 1\}$. Then, the maximum possible value of the determinant of P is

Fill in the Blanks

28. For positive numbers x, y and z , the numerical value of the determinant $\begin{vmatrix} 1 & \log_x y & \log_x z \\ \log_y x & 1 & \log_y z \\ \log_z x & \log_z y & 1 \end{vmatrix}$ is..... (1993, 2M)

29. The value of the determinant $\begin{vmatrix} 1 & a & a^2 - bc \\ 1 & b & b^2 - ca \\ 1 & c & c^2 - ab \end{vmatrix}$ is ... (1988, 2M)

30. Given that $x = -9$ is a root of $\begin{vmatrix} x & 3 & 7 \\ 2 & x & 2 \\ 7 & 6 & x \end{vmatrix} = 0$, the other two roots are... and... (1983, 2M)

31. The solution set of the equation $\begin{vmatrix} 1 & 4 & 20 \\ 1 & -2 & 5 \\ 1 & 2x & 5x^2 \end{vmatrix} = 0$ is... . (1981, 2M)

32. Let $p\lambda^4 + q\lambda^3 + r\lambda^2 + s\lambda + t = \begin{vmatrix} \lambda^2 + 3\lambda & \lambda - 1 & \lambda + 3 \\ \lambda + 1 & -2\lambda & \lambda - 4 \\ \lambda - 3 & \lambda + 4 & 3\lambda \end{vmatrix}$ be an identity in λ , where p, q, r, s and t are constants. Then, the value of t is... . (1981, 2M)

True/False

33. The determinants $\begin{vmatrix} 1 & a & bc \\ 1 & b & ca \\ 1 & c & ab \end{vmatrix}$ and $\begin{vmatrix} 1 & a & a^2 \\ 1 & b & b^2 \\ 1 & c & c^2 \end{vmatrix}$ are not identically equal. (1983, 1M)

Analytical and Descriptive Questions

34. If M is a 3×3 matrix, where $M^T M = I$ and $\det(M) = 1$, then prove that $\det(M - I) = 0$ (2004, 2M)

35. Let a, b, c be real numbers with $a^2 + b^2 + c^2 = 1$. Show that the equation $\begin{vmatrix} ax - by - c & bx + ay & cx + a \\ bx + ay & -ax + by - c & cy + b \\ cx + a & cy + b & -ax - by + c \end{vmatrix} = 0$ represents a straight line. (2001, 6M)

36. Prove that for all values of θ $\begin{vmatrix} \sin \theta & \cos \theta & \sin 2\theta \\ \sin\left(\theta + \frac{2\pi}{3}\right) & \cos\left(\theta + \frac{2\pi}{3}\right) & \sin\left(2\theta + \frac{4\pi}{3}\right) \\ \sin\left(\theta - \frac{2\pi}{3}\right) & \cos\left(\theta - \frac{2\pi}{3}\right) & \sin\left(2\theta - \frac{4\pi}{3}\right) \end{vmatrix} = 0$ (2000, 3M)

37. Suppose, $f(x)$ is a function satisfying the following conditions
 (a) $f(0) = 2, f(1) = 1$
 (b) f has a minimum value at $x = 5/2$, and
 (c) for all $x, f'(x) = \begin{vmatrix} 2ax & 2ax - 1 & 2ax + b + 1 \\ b & b + 1 & -1 \\ 2(ax + b) & 2ax + 2b + 1 & 2ax + b \end{vmatrix}$
 where a, b are some constants. Determine the constants a, b and the function $f(x)$. (1998, 3M)

38. Find the value of the determinant $\begin{vmatrix} bc & ca & ab \\ p & q & r \\ 1 & 1 & 1 \end{vmatrix}$, where a, b and c are respectively the p th, q th and r th terms of a harmonic progression. (1997C, 2M)

39. Let $a > 0, d > 0$. Find the value of the determinant $\begin{vmatrix} \frac{1}{a} & \frac{1}{a(a+d)} & \frac{1}{(a+d)(a+2d)} \\ 1 & 1 & 1 \\ (a+d) & (a+d)(a+2d) & (a+2d)(a+3d) \\ 1 & 1 & 1 \\ (a+2d) & (a+2d)(a+3d) & (a+3d)(a+4d) \end{vmatrix}$

40. For all values of A, B, C and P, Q, R , show that $\begin{vmatrix} \cos(A-P) & \cos(A-Q) & \cos(A-R) \\ \cos(B-P) & \cos(B-Q) & \cos(B-R) \\ \cos(C-P) & \cos(C-Q) & \cos(C-R) \end{vmatrix} = 0$ (1994, 4M)

41. For a fixed positive integer n , if $D = \begin{vmatrix} n! & (n+1)! & (n+2)! \\ (n+1)! & (n+2)! & (n+3)! \\ (n+2)! & (n+3)! & (n+4)! \end{vmatrix}$, then show that $\left[\frac{D}{(n!)^3} - 4\right]$ is divisible by n . (1992, 4M)

42. If $a \neq p, b \neq q, c \neq r$ and $\begin{vmatrix} p & b & c \\ a & q & c \\ a & b & r \end{vmatrix} = 0$. Then, find the value of $\frac{p}{p-a} + \frac{q}{q-b} + \frac{r}{r-c}$. (1991, 4M)

43. Let the three digit numbers $A28, 3B9$ and $62C$, where A, B and C are integers between 0 and 9, be divisible by a fixed integer k . Show that the determinant $\begin{vmatrix} A & 3 & 6 \\ 8 & 9 & C \\ 2 & B & 2 \end{vmatrix}$ is divisible by k . (1990, 4M)

44. Let $\Delta_a = \begin{vmatrix} a-1 & n & 6 \\ (a-1)^2 & 2n^2 & 4n-2 \\ (a-1)^3 & 3n^3 & 3n^2-3n \end{vmatrix}$. Show that $\sum_{a=1}^n \Delta_a = c \in \text{constant}$. (1989, 5M)

45. Show that $\begin{vmatrix} {}^x C_r & {}^x C_{r+1} & {}^x C_{r+2} \\ {}^y C_r & {}^y C_{r+1} & {}^y C_{r+2} \\ {}^z C_r & {}^z C_{r+1} & {}^z C_{r+2} \end{vmatrix} = \begin{vmatrix} {}^x C_r & {}^{x+1} C_{r+1} & {}^{x+2} C_{r+2} \\ {}^y C_r & {}^{y+1} C_{r+1} & {}^{y+2} C_{r+2} \\ {}^z C_r & {}^{z+1} C_{r+1} & {}^{z+2} C_{r+2} \end{vmatrix}$ (1985, 3M)

46. If α be a repeated root of a quadratic equation $f(x) = 0$ and $A(x), B(x)$ and $C(x)$ be polynomials of degree 3, 4 and 5 respectively, then show that $\begin{vmatrix} A(x) & B(x) & C(x) \\ A(\alpha) & B(\alpha) & C(\alpha) \\ A'(\alpha) & B'(\alpha) & C'(\alpha) \end{vmatrix}$

is divisible by $f(x)$, where prime denotes the derivatives. (1984, 3M)

47. Without expanding a determinant at any stage, show that $\begin{vmatrix} x^2 + x & x + 1 & x - 2 \\ 2x^2 + 3x - 1 & 3x & 3x - 3 \\ x^2 + 2x + 3 & 2x - 1 & 2x - 1 \end{vmatrix} = xA + B$

where A and B are determinants of order 3 not involving x . (1982, 5M)

48. Let a, b, c be positive and not all equal. Show that the value of the determinant $\begin{vmatrix} a & b & c \\ b & c & a \\ c & a & b \end{vmatrix}$ is negative. (1981, 4M)

Topic 3 Adjoint and Inverse of a Matrix

Objective Questions I (Only one correct option)

1. Let $M = \begin{bmatrix} \sin^4 \theta & -1 - \sin^2 \theta \\ 1 + \cos^2 \theta & \cos^4 \theta \end{bmatrix} = \alpha I + \beta M^{-1}$,

where $\alpha = \alpha(\theta)$ and $\beta = \beta(\theta)$ are real numbers, and I is the 2×2 identity matrix. If α^* is the minimum of the set $\{\alpha(\theta) : \theta \in [0, 2\pi)\}$ and β^* is the minimum of the set $\{\beta(\theta) : \theta \in [0, 2\pi)\}$, then the value of $\alpha^* + \beta^*$ is

(2019 Adv.)

- (a) $-\frac{17}{16}$ (b) $-\frac{31}{16}$
 (c) $-\frac{37}{16}$ (d) $-\frac{29}{16}$

2. If $B = \begin{bmatrix} 5 & 2\alpha & 1 \\ 0 & 2 & 1 \\ \alpha & 3 & -1 \end{bmatrix}$ is the inverse of a 3×3 matrix A , then

the sum of all values of α for which $\det(A) + 1 = 0$, is

(2019 Main, 12 April I)

- (a) 0 (b) -1
 (c) 1 (d) 2

3. If $A = \begin{bmatrix} e^t & e^{-t} \cos t & e^{-t} \sin t \\ e^t & -e^{-t} \cos t - e^{-t} \sin t & -e^{-t} \sin t + e^{-t} \cos t \\ e^t & 2e^{-t} \sin t & -2e^{-t} \cos t \end{bmatrix}$ then A

is (2019 Main, 9 Jan II)

- (a) invertible only when $t = \pi$
 (b) invertible for every $t \in R$
 (c) not invertible for any $t \in R$
 (d) invertible only when $t = \frac{\pi}{2}$

4. Let A and B be two invertible matrices of order 3×3 . If $\det(ABA^T) = 8$ and $\det(AB^{-1}) = 8$, then $\det(BA^{-1}B^T)$ is equal to

(2019 Main, 11 Jan II)

- (a) 1 (b) $\frac{1}{4}$
 (c) $\frac{1}{16}$ (d) 16

5. If $A = \begin{bmatrix} \cos \theta & -\sin \theta \\ \sin \theta & \cos \theta \end{bmatrix}$, then the matrix

A^{-50} when $\theta = \frac{\pi}{12}$, is equal to

(2019 Main, 9 Jan I)

- (a) $\begin{bmatrix} \frac{1}{2} & \frac{\sqrt{3}}{2} \\ -\frac{\sqrt{3}}{2} & \frac{1}{2} \end{bmatrix}$ (b) $\begin{bmatrix} \frac{\sqrt{3}}{2} & -\frac{1}{2} \\ \frac{1}{2} & \frac{\sqrt{3}}{2} \end{bmatrix}$
 (c) $\begin{bmatrix} \frac{\sqrt{3}}{2} & \frac{1}{2} \\ \frac{1}{2} & \frac{\sqrt{3}}{2} \end{bmatrix}$ (d) $\begin{bmatrix} \frac{1}{2} & -\frac{\sqrt{3}}{2} \\ \frac{\sqrt{3}}{2} & \frac{1}{2} \end{bmatrix}$

6. If $A = \begin{bmatrix} 2 & -3 \\ -4 & 1 \end{bmatrix}$, then $\text{adj}(3A^2 + 12A)$ is equal to (2017 Main)

- (a) $\begin{bmatrix} 72 & -84 \\ -63 & 51 \end{bmatrix}$ (b) $\begin{bmatrix} 51 & 63 \\ 84 & 72 \end{bmatrix}$
 (c) $\begin{bmatrix} 51 & 84 \\ 63 & 72 \end{bmatrix}$ (d) $\begin{bmatrix} 72 & -63 \\ -84 & 51 \end{bmatrix}$

7. If $A = \begin{bmatrix} 5a & -b \\ 3 & 2 \end{bmatrix}$ and $A \text{ adj } A = AA^T$, then $5a + b$ is equal to (2016 Main)

- (a) -1 (b) 5
 (c) 4 (d) 13

8. If A is a 3×3 non-singular matrix such that $AA^T = A^T A$ and $B = A^{-1}A^T$, then BB^T is equal to (2014 Main)

- (a) $I + B$ (b) I
 (c) B^{-1} (d) $(B^{-1})^T$

9. If $P = \begin{bmatrix} 1 & \alpha & 3 \\ 1 & 3 & 3 \\ 2 & 4 & 4 \end{bmatrix}$ is the adjoint of a 3×3 matrix A and $|A| = 4$, then α is equal to (2013 Main)

- (a) 4 (b) 11
 (c) 5 (d) 0

10. If P is a 3×3 matrix such that $P^T = 2P + I$, where P^T is the transpose of P and I is the 3×3 identity matrix, then

there exists a column matrix, $X = \begin{bmatrix} x \\ y \\ z \end{bmatrix} \neq \begin{bmatrix} 0 \\ 0 \\ 0 \end{bmatrix}$ such that (2012)

- (a) $PX = \begin{bmatrix} 0 \\ 0 \\ 0 \end{bmatrix}$ (b) $PX = X$
 (c) $PX = 2X$ (d) $PX = -X$

11. Let $\omega \neq 1$ be a cube root of unity and S be the set of all

non-singular matrices of the form $\begin{bmatrix} 1 & a & b \\ \omega & 1 & c \\ \omega^2 & \omega & 1 \end{bmatrix}$, where

each of a, b and c is either ω or ω^2 . Then, the number of distinct matrices in the set S is (2011)

- (a) 2 (b) 6
 (c) 4 (d) 8

12. Let M and N be two 3×3 non-singular skew-symmetric matrices such that $MN = NM$. If P^T denotes the transpose of P , then $M^2 N^2 (M^T N)^{-1} (MN^{-1})^T$ is equal to (2011)

- (a) M^2 (b) $-N^2$
 (c) $-M^2$ (d) MN

13. If $A = \begin{bmatrix} 1 & 0 & 0 \\ 0 & 1 & 1 \\ 0 & -2 & 4 \end{bmatrix}$, $6A^{-1} = A^2 + cA + dI$, then (c, d) is (2005, 1M)
- (a) $(-6, 11)$ (b) $(-11, 6)$
 (c) $(11, 6)$ (d) $(6, 11)$

Objective Questions II

(One or more than one correct option)

14. Let M be a 3×3 invertible matrix with real entries and let I denote the 3×3 identity matrix. If $M^{-1} = \text{adj}(\text{adj} M)$, then which of the following statements is/are ALWAYS TRUE? (2020 Adv.)
- (a) $M = I$ (b) $\det M = 1$
 (c) $M^2 = I$ (d) $(\text{adj } M)^2 = I$

15. Let $M = \begin{bmatrix} 0 & 1 & \alpha \\ 1 & 2 & 3 \\ 3 & b & 1 \end{bmatrix}$ and $\text{adj } M = \begin{bmatrix} -1 & 1 & -1 \\ 8 & -6 & 2 \\ -5 & 3 & -1 \end{bmatrix}$ where α and b are real numbers. Which of the following options is/are correct? (2019 Adv.)

- (a) $\det(\text{adj } M^2) = 81$
 (b) If $M \begin{bmatrix} \alpha \\ \beta \\ \gamma \end{bmatrix} = \begin{bmatrix} 1 \\ 2 \\ 3 \end{bmatrix}$, then $\alpha - \beta + \gamma = 3$
 (c) $(\text{adj } M)^{-1} + \text{adj } M^{-1} = -M$
 (d) $a + b = 3$

16. Let $P = \begin{bmatrix} 3 & -1 & -2 \\ 2 & 0 & \alpha \\ 3 & -5 & 0 \end{bmatrix}$, where $\alpha \in R$. Suppose $Q = [q_{ij}]$ is a matrix such that $PQ = kI$, where $k \in R, k \neq 0$ and I is the

identity matrix of order 3. If $q_{23} = -\frac{k}{8}$ and $\det(Q) = \frac{k^2}{2}$, then (2016 Adv.)

(a) $\alpha = 0, k = 8$ (b) $4\alpha - k + 8 = 0$
 (c) $\det(P \text{ adj } (Q)) = 2^9$ (d) $\det(Q \text{ adj } (P)) = 2^{13}$

17. Let M be a 2×2 symmetric matrix with integer entries. Then, M is invertible, if (2014 Adv.)
- (a) the first column of M is the transpose of the second row of M
 (b) the second row of M is the transpose of the first column of M
 (c) M is a diagonal matrix with non-zero entries in the main diagonal
 (d) the product of entries in the main diagonal of M is not the square of an integer

18. If the adjoint of a 3×3 matrix P is $\begin{bmatrix} 1 & 4 & 4 \\ 2 & 1 & 7 \\ 1 & 1 & 3 \end{bmatrix}$, then the possible value(s) of the determinant of P is/are
- (a) -2 (b) -1 (c) 1 (d) 2

Integer & Numerical Answer Type Question

19. Let k be a positive real number and let

$$A = \begin{bmatrix} 2k-1 & 2\sqrt{k} & 2\sqrt{k} \\ 2\sqrt{k} & 1 & -2k \\ -2\sqrt{k} & 2k & -1 \end{bmatrix} \text{ and}$$

$$B = \begin{bmatrix} 0 & 2k-1 & \sqrt{k} \\ 1-2k & 0 & 2\sqrt{k} \\ -\sqrt{k} & -2\sqrt{k} & 0 \end{bmatrix}$$

If $\det(\text{adj } A) + \det(\text{adj } B) = 10^6$, then $[k]$ is equal to..... (2010)

Topic 4 Solving System of Equations

Objective Questions I (Only one correct option)

1. If $[x]$ denotes the greatest integer $\leq x$, then the system of linear equations $[\sin \theta]x + [-\cos \theta]y = 0, [\cot \theta]x + y = 0$ (2019 Main, 12 April II)
- (a) have infinitely many solutions if $\theta \in \left(\frac{\pi}{2}, \frac{2\pi}{3}\right)$ and has a unique solution if $\theta \in \left(\pi, \frac{7\pi}{6}\right)$.
 (b) has a unique solution if $\theta \in \left(\frac{\pi}{2}, \frac{2\pi}{3}\right) \cup \left(\pi, \frac{7\pi}{6}\right)$
 (c) has a unique solution if $\theta \in \left(\frac{\pi}{2}, \frac{2\pi}{3}\right)$ and have infinitely many solutions if $\theta \in \left(\pi, \frac{7\pi}{6}\right)$
 (d) have infinitely many solutions if $\theta \in \left(\frac{\pi}{2}, \frac{2\pi}{3}\right) \cup \left(\pi, \frac{7\pi}{6}\right)$

2. Let λ be a real number for which the system of linear equations $x + y + z = 6, 4x + \lambda y - \lambda z = \lambda - 2$ and $3x + 2y - 4z = -5$ has infinitely many solutions. Then λ is a root of the quadratic equation (2019 Main, 10 April II)
- (a) $\lambda^2 - 3\lambda - 4 = 0$ (b) $\lambda^2 + 3\lambda - 4 = 0$
 (c) $\lambda^2 - \lambda - 6 = 0$ (d) $\lambda^2 + \lambda - 6 = 0$
3. If the system of linear equations $x + y + z = 5$ $x + 2y + 2z = 6$ $x + 3y + \lambda z = \mu, (\lambda, \mu \in R)$, has infinitely many solutions, then the value of $\lambda + \mu$ is (2019 Main, 10 April I)
- (a) 7 (b) 12 (c) 10 (d) 9

142 Matrices and Determinants

4. If the system of equations $2x + 3y - z = 0$, $x + ky - 2z = 0$ and $2x - y + z = 0$ has a non-trivial solution (x, y, z) , then $\frac{x}{y} + \frac{y}{z} + \frac{z}{x} + k$ is equal to
(2019 Main, 9 April II)
- (a) -4 (b) $\frac{1}{2}$ (c) $-\frac{1}{4}$ (d) $\frac{3}{4}$
5. If the system of linear equations $x - 2y + kz = 1$, $2x + y + z = 2$, $3x - y - kz = 3$ has a solution (x, y, z) , $z \neq 0$, then (x, y) lies on the straight line whose equation is (2019 Main, 8 April II)
- (a) $3x - 4y - 4 = 0$ (b) $3x - 4y - 1 = 0$
(c) $4x - 3y - 4 = 0$ (d) $4x - 3y - 1 = 0$
6. The greatest value of $c \in \mathbb{R}$ for which the system of linear equations $x - cy - cz = 0$, $cx - y + cz = 0$, $cx + cy - z = 0$ has a non-trivial solution, is (2019 Main, 8 April I)
- (a) -1 (b) $\frac{1}{2}$ (c) 2 (d) 0
7. The set of all values of λ for which the system of linear equations $x - 2y - 2z = \lambda x$, $x + 2y + z = \lambda y$ and $-x - y = \lambda z$ has a non-trivial solution (2019 Main, 12 Jan II)
- (a) contains exactly two elements.
(b) contains more than two elements.
(c) is a singleton.
(d) is an empty set.
8. An ordered pair (α, β) for which the system of linear equations (2019 Main, 12 Jan I)
- $$(1 + \alpha)x + \beta y + z = 2$$
- $$\alpha x + (1 + \beta)y + z = 3$$
- $$ax + \beta y + 2z = 2$$
- has a unique solution, is
- (a) $(2, 4)$ (b) $(-4, 2)$
(c) $(1, -3)$ (d) $(-3, 1)$
9. If the system of linear equations
- $$2x + 2y + 3z = a$$
- $$3x - y + 5z = b$$
- $$x - 3y + 2z = c$$
- where a, b, c are non-zero real numbers, has more than one solution, then (2019 Main, 11 Jan I)
- (a) $b - c - a = 0$ (b) $a + b + c = 0$
(c) $b - c + a = 0$ (d) $b + c - a = 0$
10. The number of values of $\theta \in (0, \pi)$ for which the system of linear equations
- $$x + 3y + 7z = 0,$$
- $$-x + 4y + 7z = 0,$$
- $$(\sin 3\theta)x + (\cos 2\theta)y + 2z = 0$$
- has a non-trivial solution, is (2019 Main, 10 Jan II)
- (a) two (b) three (c) four (d) one
11. If the system of equations
- $$x + y + z = 5 \quad x + 2y + 3z = 9$$
- $$x + 3y + \alpha z = \beta$$
- has infinitely many solutions, then $\beta - \alpha$ equals (2019 Main, 10 Jan I)
- (a) 8 (b) 18 (c) 21 (d) 5
12. If the system of linear equations
- $$x - 4y + 7z = g,$$
- $$3y - 5z = h, \quad -2x + 5y - 9z = k$$
- is consistent, then (2019 Main, 9 Jan II)
- (a) $2g + h + k = 0$ (b) $g + 2h + k = 0$
(c) $g + h + k = 0$ (d) $g + h + 2k = 0$
13. The system of linear equations
- $$x + y + z = 2, \quad 2x + 3y + 2z = 5$$
- $$2x + 3y + (a^2 - 1)z = a + 1$$
- (2019 Main, 9 Jan I)
- (a) has infinitely many solutions for $a = 4$
(b) is inconsistent when $a = 4$
(c) has a unique solution for $|a| = \sqrt{3}$
(d) is inconsistent when $|a| = \sqrt{3}$
14. If the system of linear equations
- $$x + ky + 3z = 0, \quad 3x + ky - 2z = 0, \quad 2x + 4y - 3z = 0$$
- has a non-zero solution (x, y, z) , then $\frac{xz}{y^2}$ is equal to (2018 Main)
- (a) -10 (b) 10 (c) -30 (d) 30
15. The system of linear equations
- $$x + \lambda y - z = 0; \quad \lambda x - y - z = 0; \quad x + y - \lambda z = 0$$
- has a non-trivial solution for (2016 Main)
- (a) infinitely many values of λ (b) exactly one value of λ
(c) exactly two values of λ (d) exactly three values of λ
16. The set of all values of λ for which the system of linear equations $2x_1 - 2x_2 + x_3 = \lambda x_1$, $2x_1 - 3x_2 + 2x_3 = \lambda x_2$ and $-x_1 + 2x_2 = \lambda x_3$ has a non-trivial solution (2015 Main)
- (a) is an empty set
(b) is a singleton set
(c) contains two elements
(d) contains more than two elements
17. The number of value of k , for which the system of equation
- $$(k + 1)x + 8y = 4y \Rightarrow kx + (k + 3)y = 3k - 1$$
- has no solution, is (2013 Main)
- (a) infinite (b) 1 (c) 2 (d) 3
18. The number of 3×3 matrices A whose entries are either 0 or 1 and for which the system $A \begin{bmatrix} x \\ y \\ z \end{bmatrix} = \begin{bmatrix} 1 \\ 0 \\ 0 \end{bmatrix}$ has exactly two distinct solutions, is (2010)
- (a) 0 (b) $2^9 - 1$ (c) 168 (d) 2
19. Given, $2x - y + 2z = 2$, $x - 2y + z = -4$, $x + y + \lambda z = 4$, then the value of λ such that the given system of equations has no solution, is (2004, 1M)
- (a) 3 (b) 1 (c) 0 (d) -3
20. The number of values of k for which the system of equations $(k + 1)x + 8y = 4k$ and $kx + (k + 3)y = 3k - 1$ has infinitely many solutions, is/are (2002, 1M)
- (a) 0 (b) 1
(c) 2 (d) ∞
21. If the system of equations $x + ay = 0$, $az + y = 0$ and $ax + z = 0$ has infinite solutions, then the value of a is
- (a) -1 (b) 1
(c) 0 (d) no real values

22. If the system of equations $x - ky - z = 0$, $kx - y - z = 0$, $x + y - z = 0$ has a non-zero solution, then possible values of k are (2000, 2M)
- (a) $-1, 2$ (b) $1, 2$ (c) $0, 1$ (d) $-1, 1$

Assertion and Reason

For the following questions, choose the correct answer from the codes (a), (b), (c) and (d) defined as follows.

- (a) Statement I is true, Statement II is also true; Statement II is the correct explanation of Statement I
 (b) Statement I is true, Statement II is also true; Statement II is not the correct explanation of Statement I
 (c) Statement I is true; Statement II is false.
 (d) Statement I is false; Statement II is true.
23. Consider the system of equations $x - 2y + 3z = -1$, $x - 3y + 4z = 1$ and $-x + y - 2z = k$

Statement I The system of equations has no solution for $k \neq 3$ and

Statement II The determinant $\begin{vmatrix} 1 & 3 & -1 \\ -1 & -2 & k \\ 1 & 4 & 1 \end{vmatrix} \neq 0$, for $k \neq 0$. (2008, 3M)

Objective Questions II (One or more than one correct)

24. Let $x \in R$ and let

$$P = \begin{bmatrix} 1 & 1 & 1 \\ 0 & 2 & 2 \\ 0 & 0 & 3 \end{bmatrix}, Q = \begin{bmatrix} 2 & x & x \\ 0 & 4 & 0 \\ x & x & 6 \end{bmatrix} \text{ and } R = PQP^{-1},$$

the which of the following options is/are correct? (2019 Adv.)

- (a) There exists a real, number x such that $PQ = QP$
 (b) For $x = 0$, if $R \begin{bmatrix} 1 \\ a \\ b \end{bmatrix} = 6 \begin{bmatrix} 1 \\ a \\ b \end{bmatrix}$, then $a + b = 5$
 (c) For $x = 1$, there exists a unit vector $\alpha \hat{i} + \beta \hat{j} + \gamma \hat{k}$ for

$$\text{which } R \begin{bmatrix} \alpha \\ \beta \\ \gamma \end{bmatrix} = \begin{bmatrix} 0 \\ 0 \\ 0 \end{bmatrix}$$

- (d) $\det R = \det \begin{bmatrix} 2 & x & x \\ 0 & 4 & 0 \\ x & x & 5 \end{bmatrix} + 8$, for all $x \in R$

25. Let S be the set of all column matrices $\begin{bmatrix} b_1 \\ b_2 \\ b_3 \end{bmatrix}$ such that $b_1, b_2, b_3 \in R$ and the system of equations (in real variables)

$$\begin{aligned} -x + 2y + 5z &= b_1 \\ 2x - 4y + 3z &= b_2 \\ x - 2y + 2z &= b_3 \end{aligned}$$

has at least one solution. Then, which of the following system(s) (in real variables) has (have) at least one

solution for each $\begin{bmatrix} b_1 \\ b_2 \\ b_3 \end{bmatrix} \in S$?

- (a) $x + 2y + 3z = b_1$, $4y + 5z = b_2$ and $x + 2y + 6z = b_3$
 (b) $x + y + 3z = b_1$, $5x + 2y + 6z = b_2$ and $-2x - y - 3z = b_3$
 (c) $-x + 2y - 5z = b_1$, $2x - 4y + 10z = b_2$ and $x - 2y + 5z = b_3$
 (d) $x + 2y + 5z = b_1$, $2x + 3z = b_2$ and $x + 4y - 5z = b_3$

Fill in the Blank

26. The system of equations $\lambda x + y + z = 0$, $-x + \lambda y + z = 0$ and $-x - y + \lambda z = 0$ will have a non-zero solution, if real values of λ are given by ... (1982, 2M)

Analytical and Descriptive Questions

27. $A = \begin{bmatrix} a & 0 & 1 \\ 1 & c & b \\ 1 & d & b \end{bmatrix}, B = \begin{bmatrix} a & 1 & 1 \\ 0 & d & c \\ f & g & h \end{bmatrix}, U = \begin{bmatrix} f \\ g \\ h \end{bmatrix}, V = \begin{bmatrix} a^2 \\ 0 \\ 0 \end{bmatrix}$

If there is a vector matrix X , such that $AX = U$ has infinitely many solutions, then prove that $BX = V$ cannot have a unique solution. If $a f d \neq 0$. Then, prove that $BX = V$ has no solution. (2004, 4M)

28. Let λ and α be real. Find the set of all values of λ for which the system of linear equations

$$\begin{aligned} \lambda x + (\sin \alpha)y + (\cos \alpha)z &= 0, \\ x + (\cos \alpha)y + (\sin \alpha)z &= 0 \end{aligned}$$

and $-x + (\sin \alpha)y - (\cos \alpha)z = 0$ has a non-trivial solution.

For $\lambda = 1$, find all values of α . (1993, 5M)

29. Let $\alpha_1, \alpha_2, \beta_1, \beta_2$ be the roots of $ax^2 + bx + c = 0$ and $px^2 + qx + r = 0$, respectively. If the system of equations $\alpha_1 y + \alpha_2 z = 0$ and $\beta_1 y + \beta_2 z = 0$ has a non-trivial solution, then prove that $\frac{b^2}{q^2} = \frac{ac}{pr}$. (1987, 3M)

30. Consider the system of linear equations in x, y, z
 $(\sin 3\theta)x - y + z = 0$, $(\cos 2\theta)x + 4y + 3z = 0$ and $2x + 7y + 7z = 0$

Find the values of θ for which this system has non-trivial solution. (1986, 5M)

31. Show that the system of equations, $3x - y + 4z = 3$, $x + 2y - 3z = -2$ and $6x + 5y + \lambda z = -3$ has at least one solution for any real number $\lambda \neq -5$. Find the set of solutions, if $\lambda = -5$. (1983, 5M)

32. For what values of m , does the system of equations $3x + my = m$ and $2x - 5y = 20$ has a solution satisfying the conditions $x > 0, y > 0$? (1979, 3M)

33. For what value of k , does the following system of equations possess a non-trivial solution over the set of rationals

$$x + y - 2z = 0, 2x - 3y + z = 0, \text{ and } x - 5y + 4z = k$$

Find all the solutions. (1979, 3M)

34. Given, $x = cy + bz, y = az + cx, z = bx + ay$, where x, y, z are not all zero, prove that $a^2 + b^2 + c^2 + 2ab = 1$. (1978, 2M)

144 Matrices and Determinants

Integer & Numerical Answer Type Questions

35. If the system of equations

$$x - 2y + 3z = 9$$

$$2x + y + z = b$$

$$x - 7y + az = 24,$$
 has infinitely many solutions, then $a - b$ is equal to (2020 Main, 4 Sep I)
36. If the system of linear equations,

$$x + y + z = 6$$

$$x + 2y + 3z = 10$$

$$3x + 2y + \lambda z = \mu$$
 has more than two solutions, then $\mu - \lambda^2$ is equal to (2020 Main, 7 Jan II)

37. For a real number α , if the system

$$\begin{bmatrix} 1 & \alpha & \alpha^2 \\ \alpha & 1 & \alpha \\ \alpha^2 & \alpha & 1 \end{bmatrix} \begin{bmatrix} x \\ y \\ z \end{bmatrix} = \begin{bmatrix} 1 \\ -1 \\ 1 \end{bmatrix}$$

of linear equations, has infinitely many solutions, then $1 + \alpha + \alpha^2 =$ (2017 Adv.)

38. Let M be a 3×3 matrix satisfying $M \begin{bmatrix} 0 \\ 1 \\ 0 \end{bmatrix} = \begin{bmatrix} -1 \\ 2 \\ 3 \end{bmatrix}$,

$$M \begin{bmatrix} 1 \\ -1 \\ 0 \end{bmatrix} = \begin{bmatrix} 1 \\ 1 \\ -1 \end{bmatrix}, \text{ and } M \begin{bmatrix} 1 \\ 1 \\ 1 \end{bmatrix} = \begin{bmatrix} 0 \\ 0 \\ 12 \end{bmatrix},$$

Then, the sum of the diagonal entries of M is ... (2011)

Answers

Topic 1

- | | | | |
|------------|---------------|-------------|------------|
| 1. (b) | 2. (b) | 3. (c) | 4. (a) |
| 5. (b) | 6. (b) | 7. (d) | 8. (a) |
| 9. (d) | 10. (a) | 11. (a,b,d) | 12. (c, d) |
| 13. (c, d) | 14. (b, c, d) | 15. (d) | 16. (b) |
| 17. (a) | 18. (d) | 19. (c) | 20. (d) |
| 21. (4) | 22. (5) | 23. (1) | |

Topic 2

- | | | | |
|------------|--|-----------------|------------|
| 1. (d) | 2. (a) | 3. (a) | 4. (c) |
| 5. (b) | 6. (d) | 7. (c) | 8. (a) |
| 9. (b) | 10. (d) | 11. (c) | 12. (a) |
| 13. (c) | 14. (a) | 15. (c) | 16. (d) |
| 17. (c) | 18. (c) | 19. (a) | 20. (b) |
| 21. (b) | 22. (b) | 23. (a, c) | 24. (b, c) |
| 25. (a, b) | 26. (b,d) | 27. (4) | 28. (0) |
| 29. (0) | 30. (2 and 7) | 31. $\{-1, 2\}$ | 32. (0) |
| 33. False | 37. $\left(a = \frac{1}{4}, b = -\frac{5}{4} \text{ and } f(x) = \frac{1}{4}x^2 - \frac{5}{4}x + 2 \right)$ | | |
| 38. (0) | 39. $\left(\frac{4d^4}{a(a+d)^2(a+2d)^3(a+3d)^2(a+4d)} \right)$ | | |
| 42. (2) | | | |

Topic 3

- | | | | |
|------------|-------------|-------------|-----------|
| 1. (d) | 2. (c) | 3. (b) | 4. (c) |
| 5. (c) | 6. (b) | 7. (b) | 8. (b) |
| 9. (b) | 10. (d) | 11. (a) | 12. (c) |
| 13. (a) | 14. (b,c,d) | 15. (b,c,d) | 16. (b,c) |
| 17. (c, d) | 18. (a,d) | 19. (4) | |

Topic 4

- | | | | |
|---|-------------------------------------|---------|-----------|
| 1. (a) | 2. (c) | 3. (c) | 4. (b) |
| 5. (c) | 6. (b) | 7. (c) | 8. (a) |
| 9. (a) | 10. (a) | 11. (a) | 12. (a) |
| 13. (d) | 14. (b) | 15. (d) | 16. (c) |
| 17. (d) | 18. (a) | 19. (b) | 20. (b) |
| 21. (a) | 22. (d) | 23. (a) | 24. (b,d) |
| 25. (a,d) | 26. $\lambda = 0$ | | |
| 28. $-\sqrt{2} \leq \lambda \leq \sqrt{2}, \alpha = n\pi, n\pi + \frac{\pi}{4}$ | | | |
| 30. $\theta = n\pi, n\pi + (-1)^n \frac{\pi}{6}, n \in Z$ | | | |
| 31. $x = \frac{4-5k}{7}, y = \frac{13k-9}{7}, z = k$ | 32. $m < -\frac{15}{2}$ or $m > 30$ | | |
| 33. ($k = 0$, the given system has infinitely many solutions) | | | |
| 35. (5) | 36. (13) | 37. (1) | 38. (9) |

Hints & Solutions

Topic 1 Types of Matrices, Addition, Subtraction and Transpose of a Matrix

1. Given matrix A is a symmetric and matrix B is a skew-symmetric.

$$\therefore A^T = A \text{ and } B^T = -B$$

$$\text{Since, } A + B = \begin{bmatrix} 2 & 3 \\ 5 & -1 \end{bmatrix} \quad (\text{given}) \dots(i)$$

On taking transpose both sides, we get

$$(A + B)^T = \begin{bmatrix} 2 & 3 \\ 5 & -1 \end{bmatrix}^T$$

$$\Rightarrow A^T + B^T = \begin{bmatrix} 2 & 5 \\ 3 & -1 \end{bmatrix} \quad \dots(ii)$$

Given, $A^T = A$ and $B^T = -B$

$$\Rightarrow A - B = \begin{bmatrix} 2 & 5 \\ 3 & -1 \end{bmatrix}$$

On solving Eqs. (i) and (ii), we get

$$A = \begin{bmatrix} 2 & 4 \\ 4 & -1 \end{bmatrix} \text{ and } B = \begin{bmatrix} 0 & -1 \\ 1 & 0 \end{bmatrix}$$

$$\text{So, } AB = \begin{bmatrix} 2 & 4 \\ 4 & -1 \end{bmatrix} \begin{bmatrix} 0 & -1 \\ 1 & 0 \end{bmatrix} = \begin{bmatrix} 4 & -2 \\ -1 & -4 \end{bmatrix}$$

2. Given matrix

$$A = \begin{bmatrix} 0 & 2y & 1 \\ 2x & y & -1 \\ 2x & -y & 1 \end{bmatrix}, (x, y \in R, x \neq y)$$

for which

$$A^T A = 3I_3$$

$$\Rightarrow \begin{bmatrix} 0 & 2x & 2x \\ 2y & y & -y \\ 1 & -1 & 1 \end{bmatrix} \begin{bmatrix} 0 & 2y & 1 \\ 2x & y & -1 \\ 2x & -y & 1 \end{bmatrix} = \begin{bmatrix} 3 & 0 & 0 \\ 0 & 3 & 0 \\ 0 & 0 & 3 \end{bmatrix}$$

$$\Rightarrow \begin{bmatrix} 8x^2 & 0 & 0 \\ 0 & 6y^2 & 0 \\ 0 & 0 & 3 \end{bmatrix} = \begin{bmatrix} 3 & 0 & 0 \\ 0 & 3 & 0 \\ 0 & 0 & 3 \end{bmatrix}$$

Here, two matrices are equal, therefore equating the corresponding elements, we get

$$8x^2 = 3 \text{ and } 6y^2 = 3$$

$$\Rightarrow x = \pm \sqrt{\frac{3}{8}}$$

$$\text{and } y = \pm \frac{1}{\sqrt{2}}$$

\therefore There are 2 different values of x and y each.

So, 4 matrices are possible such that $A^T A = 3I_3$.

3. Given, matrix $A = \begin{bmatrix} \cos \alpha & -\sin \alpha \\ \sin \alpha & \cos \alpha \end{bmatrix}$

$$\therefore A^2 = \begin{bmatrix} \cos \alpha & -\sin \alpha \\ \sin \alpha & \cos \alpha \end{bmatrix} \begin{bmatrix} \cos \alpha & -\sin \alpha \\ \sin \alpha & \cos \alpha \end{bmatrix}$$

$$= \begin{bmatrix} \cos^2 \alpha - \sin^2 \alpha & -\cos \alpha \sin \alpha - \sin \alpha \cos \alpha \\ \sin \alpha \cos \alpha + \cos \alpha \sin \alpha & -\sin^2 \alpha + \cos^2 \alpha \end{bmatrix}$$

$$= \begin{bmatrix} \cos 2\alpha & -\sin 2\alpha \\ \sin 2\alpha & \cos 2\alpha \end{bmatrix}$$

Similarly,

$$A^n = \begin{bmatrix} \cos(n\alpha) & -\sin(n\alpha) \\ \sin(n\alpha) & \cos(n\alpha) \end{bmatrix}, n \in N$$

$$\Rightarrow A^{32} = \begin{bmatrix} \cos(32\alpha) & -\sin(32\alpha) \\ \sin(32\alpha) & \cos(32\alpha) \end{bmatrix} = \begin{bmatrix} 0 & -1 \\ 1 & 0 \end{bmatrix} \quad (\text{given})$$

So, $\cos(32\alpha) = 0$ and $\sin(32\alpha) = 1$

$$\Rightarrow 32\alpha = \frac{\pi}{2} \Rightarrow \alpha = \frac{\pi}{64}$$

4. Given matrix

$$P = \begin{bmatrix} 1 & 0 & 0 \\ 3 & 1 & 0 \\ 9 & 3 & 1 \end{bmatrix} = \begin{bmatrix} 0 & 0 & 0 \\ 3 & 0 & 0 \\ 9 & 3 & 0 \end{bmatrix} + \begin{bmatrix} 1 & 0 & 0 \\ 0 & 1 & 0 \\ 0 & 0 & 1 \end{bmatrix}$$

$$\Rightarrow P = X + I \text{ (let)}$$

$$\text{Now, } P^5 = (I + X)^5$$

$$= I + {}^5C_1(X) + {}^5C_2(X^2) + {}^5C_3(X^3) + \dots$$

$$[\because I^n = I, I \cdot A = A \text{ and } (a+x)^n = {}^nC_0 a^n + {}^nC_1 a^{n-1}x + \dots + {}^nC_n x^n]$$

$$\text{Here, } X^2 = \begin{bmatrix} 0 & 0 & 0 \\ 3 & 0 & 0 \\ 9 & 3 & 0 \end{bmatrix} \begin{bmatrix} 0 & 0 & 0 \\ 3 & 0 & 0 \\ 9 & 3 & 0 \end{bmatrix} = \begin{bmatrix} 0 & 0 & 0 \\ 0 & 0 & 0 \\ 9 & 0 & 0 \end{bmatrix}$$

$$\text{and } X^3 = X^2 \cdot X = \begin{bmatrix} 0 & 0 & 0 \\ 0 & 0 & 0 \\ 9 & 0 & 0 \end{bmatrix} \begin{bmatrix} 0 & 0 & 0 \\ 3 & 0 & 0 \\ 9 & 3 & 0 \end{bmatrix} = \begin{bmatrix} 0 & 0 & 0 \\ 0 & 0 & 0 \\ 0 & 0 & 0 \end{bmatrix}$$

$$\Rightarrow X^4 = X^5 = \begin{bmatrix} 0 & 0 & 0 \\ 0 & 0 & 0 \\ 0 & 0 & 0 \end{bmatrix}$$

$$\text{So, } P^5 = I + 5 \begin{bmatrix} 0 & 0 & 0 \\ 3 & 0 & 0 \\ 9 & 3 & 0 \end{bmatrix} + 10 \begin{bmatrix} 0 & 0 & 0 \\ 0 & 0 & 0 \\ 9 & 0 & 0 \end{bmatrix}$$

$$= \begin{bmatrix} 1 & 0 & 0 \\ 15 & 1 & 0 \\ 135 & 15 & 1 \end{bmatrix}$$

$$\text{and } Q = I + P^5 = \begin{bmatrix} 2 & 0 & 0 \\ 15 & 2 & 0 \\ 135 & 15 & 2 \end{bmatrix} = [q_{ij}]$$

$$\Rightarrow q_{21} = 15, q_{31} = 135 \text{ and } q_{32} = 15$$

$$\text{Hence, } \frac{q_{21} + q_{31}}{q_{32}} = \frac{15 + 135}{15} = \frac{150}{15} = 10$$

146 Matrices and Determinants

5. Given, $AA^T = I$

$$\Rightarrow \begin{bmatrix} 0 & 2q & r \\ p & q & -r \\ p & -q & r \end{bmatrix} \begin{bmatrix} 0 & p & p \\ 2q & q & -q \\ r & -r & r \end{bmatrix} = \begin{bmatrix} 1 & 0 & 0 \\ 0 & 1 & 0 \\ 0 & 0 & 1 \end{bmatrix}$$

$$\Rightarrow \begin{bmatrix} 0 + 4q^2 + r^2 & 0 + 2q^2 - r^2 & 0 - 2q^2 + r^2 \\ 0 + 2q^2 - r^2 & p^2 + q^2 + r^2 & p^2 - q^2 - r^2 \\ 0 - 2q^2 + r^2 & p^2 - q^2 - r^2 & p^2 + q^2 + r^2 \end{bmatrix} = \begin{bmatrix} 1 & 0 & 0 \\ 0 & 1 & 0 \\ 0 & 0 & 1 \end{bmatrix}$$

We know that, if two matrices are equal, then corresponding elements are also equal, so

$$4q^2 + r^2 = 1 = p^2 + q^2 + r^2, \quad \dots(i)$$

$$2q^2 - r^2 = 0 \Rightarrow r^2 = 2q^2 \quad \dots(ii)$$

and $p^2 - q^2 - r^2 = 0 \quad \dots(iii)$

Using Eqs. (ii) and (iii), we get

$$p^2 = 3q^2 \quad \dots(iv)$$

Using Eqs. (ii) and (iv) in Eq. (i), we get

$$4q^2 + 2q^2 = 1$$

$$\Rightarrow 6q^2 = 1$$

$$\Rightarrow 2p^2 = 1 \quad \text{[using Eq. (iv)]}$$

$$p^2 = \frac{1}{2} \Rightarrow |p| = \frac{1}{\sqrt{2}}$$

6. Here, $P = \begin{bmatrix} 1 & 0 & 0 \\ 4 & 1 & 0 \\ 16 & 4 & 1 \end{bmatrix}$

$$\therefore P^2 = \begin{bmatrix} 1 & 0 & 0 \\ 4 & 1 & 0 \\ 16 & 4 & 1 \end{bmatrix} \begin{bmatrix} 1 & 0 & 0 \\ 4 & 1 & 0 \\ 16 & 4 & 1 \end{bmatrix} = \begin{bmatrix} 1 & 0 & 0 \\ 4 + 4 & 1 & 0 \\ 16 + 32 & 4 + 4 & 1 \end{bmatrix}$$

$$= \begin{bmatrix} 1 & 0 & 0 \\ 4 \times 2 & 1 & 0 \\ 16(1+2) & 4 \times 2 & 1 \end{bmatrix} \quad \dots(i)$$

and $P^3 = \begin{bmatrix} 1 & 0 & 0 \\ 4 \times 2 & 1 & 0 \\ 16(1+2) & 4 \times 2 & 1 \end{bmatrix} \begin{bmatrix} 1 & 0 & 0 \\ 4 & 1 & 0 \\ 16 & 4 & 1 \end{bmatrix}$

$$= \begin{bmatrix} 1 & 0 & 0 \\ 4 \times 3 & 1 & 0 \\ 16(1+2+3) & 4 \times 3 & 1 \end{bmatrix} \quad \dots(ii)$$

From symmetry,

$$P^{50} = \begin{bmatrix} 1 & 0 & 0 \\ 4 \times 50 & 1 & 0 \\ 16(1+2+3+\dots+50) & 4 \times 50 & 1 \end{bmatrix}$$

$$\therefore P^{50} - Q = I \quad \text{[given]}$$

$$\therefore \begin{bmatrix} 1 - q_{11} & -q_{12} & -q_{13} \\ 200 - q_{21} & 1 - q_{22} & -q_{23} \\ 16 \times \frac{50}{2} (51) - q_{31} & 200 - q_{32} & 1 - q_{33} \end{bmatrix} = \begin{bmatrix} 1 & 0 & 0 \\ 0 & 1 & 0 \\ 0 & 0 & 1 \end{bmatrix}$$

$$\Rightarrow 200 - q_{21} = 0, \frac{16 \times 50 \times 51}{2} - q_{31} = 0,$$

$$200 - q_{32} = 0$$

$$\therefore q_{21} = 200, q_{32} = 200, q_{31} = 20400$$

Thus, $\frac{q_{31} + q_{32}}{q_{21}} = \frac{20400 + 200}{200} = \frac{20600}{200} = 103$

7. Given, $A = \begin{bmatrix} 1 & 2 & 2 \\ 2 & 1 & -2 \\ a & 2 & b \end{bmatrix}, A^T = \begin{bmatrix} 1 & 2 & a \\ 2 & 1 & 2 \\ 2 & -2 & b \end{bmatrix}$

and $AA^T = \begin{bmatrix} 1 & 2 & 2 \\ 2 & 1 & -2 \\ a & 2 & b \end{bmatrix} \begin{bmatrix} 1 & 2 & a \\ 2 & 1 & 2 \\ 2 & -2 & b \end{bmatrix}$

$$= \begin{bmatrix} 9 & 0 & a+4+2b \\ 0 & 9 & 2a+2-2b \\ a+4+2b & 2a+2-2b & a^2+4+b^2 \end{bmatrix}$$

It is given that, $AA^T = 9I$

$$\Rightarrow \begin{bmatrix} 9 & 0 & a+4+2b \\ 0 & 9 & 2a+2-2b \\ a+4+2b & 2a+2-2b & a^2+4+b^2 \end{bmatrix} = 9 \begin{bmatrix} 1 & 0 & 0 \\ 0 & 1 & 0 \\ 0 & 0 & 1 \end{bmatrix}$$

$$\Rightarrow \begin{bmatrix} 9 & 0 & a+4+2b \\ 0 & 9 & 2a+2-2b \\ a+4+2b & 2a+2-2b & a^2+4+b^2 \end{bmatrix} = \begin{bmatrix} 9 & 0 & 0 \\ 0 & 9 & 0 \\ 0 & 0 & 9 \end{bmatrix}$$

On comparing, we get

$$a + 4 + 2b = 0 \Rightarrow a + 2b = -4 \quad \dots(i)$$

$$2a + 2 - 2b = 0 \Rightarrow a - b = -1 \quad \dots(ii)$$

and $a^2 + 4 + b^2 = 9 \quad \dots(iii)$

On solving Eqs. (i) and (ii), we get

$$a = -2, b = -1$$

This satisfies Eq. (iii)

Hence, $(a, b) \equiv (-2, -1)$

8. Now, $P^T P = \begin{bmatrix} \sqrt{3}/2 & -1/2 \\ 1/2 & \sqrt{3}/2 \end{bmatrix} \begin{bmatrix} \sqrt{3}/2 & 1/2 \\ -1/2 & \sqrt{3}/2 \end{bmatrix}$

$$\Rightarrow P^T P = \begin{bmatrix} 1 & 0 \\ 0 & 1 \end{bmatrix}$$

$$\Rightarrow P^T P = I$$

$$\Rightarrow P^T = P^{-1}$$

Since, $Q = PAP^T$

$$\therefore P^T Q^{2005} P = P^T [(PAP^T)(PAP^T) \dots 2005 \text{ times}] P$$

$$= \underbrace{(P^T P) A (P^T P) A (P^T P) \dots (P^T P) A (P^T P)}_{2005 \text{ times}}$$

$$= IA^{2005} = A^{2005}$$

$$\therefore A = \begin{bmatrix} 1 & 1 \\ 0 & 1 \end{bmatrix}$$

$$A^2 = \begin{bmatrix} 1 & 1 \\ 0 & 1 \end{bmatrix} \begin{bmatrix} 1 & 1 \\ 0 & 1 \end{bmatrix} = \begin{bmatrix} 1 & 2 \\ 0 & 1 \end{bmatrix}$$

$$A^3 = \begin{bmatrix} 1 & 2 \\ 0 & 1 \end{bmatrix} \begin{bmatrix} 1 & 1 \\ 0 & 1 \end{bmatrix} = \begin{bmatrix} 1 & 3 \\ 0 & 1 \end{bmatrix}$$

.....
.....

$$A^{2005} = \begin{bmatrix} 1 & 2005 \\ 0 & 1 \end{bmatrix}$$

$$\therefore P^T Q^{2005} P = \begin{bmatrix} 1 & 2005 \\ 0 & 1 \end{bmatrix}$$

9. Given, $A = \begin{bmatrix} \alpha & 0 \\ 1 & 1 \end{bmatrix}, B = \begin{bmatrix} 1 & 0 \\ 5 & 1 \end{bmatrix}$

$$\Rightarrow A^2 = \begin{bmatrix} \alpha & 0 \\ 1 & 1 \end{bmatrix} \begin{bmatrix} \alpha & 0 \\ 1 & 1 \end{bmatrix} = \begin{bmatrix} \alpha^2 & 0 \\ \alpha + 1 & 1 \end{bmatrix}$$

Also, given, $A^2 = B$

$$\Rightarrow \begin{bmatrix} \alpha^2 & 0 \\ \alpha + 1 & 1 \end{bmatrix} = \begin{bmatrix} 1 & 0 \\ 5 & 1 \end{bmatrix}$$

$$\Rightarrow \alpha^2 = 1 \text{ and } \alpha + 1 = 5$$

Which is not possible at the same time.

\therefore No real values of α exists.

10. If A and B are square matrices of equal degree, then

$$A + B = B + A$$

11. Given matrices,

$$P_1 = I = \begin{bmatrix} 1 & 0 & 0 \\ 0 & 1 & 0 \\ 0 & 0 & 1 \end{bmatrix}, P_2 = \begin{bmatrix} 1 & 0 & 0 \\ 0 & 0 & 1 \\ 0 & 1 & 0 \end{bmatrix}, P_3 = \begin{bmatrix} 0 & 1 & 0 \\ 1 & 0 & 0 \\ 0 & 0 & 1 \end{bmatrix}$$

$$P_4 = \begin{bmatrix} 0 & 1 & 0 \\ 0 & 0 & 1 \\ 1 & 0 & 0 \end{bmatrix}, P_5 = \begin{bmatrix} 0 & 0 & 1 \\ 1 & 0 & 0 \\ 0 & 1 & 0 \end{bmatrix}, P_6 = \begin{bmatrix} 0 & 0 & 1 \\ 0 & 1 & 0 \\ 1 & 0 & 0 \end{bmatrix}$$

$$\text{and } X = \sum_{K=1}^6 P_k \begin{bmatrix} 2 & 1 & 3 \\ 1 & 0 & 2 \\ 3 & 2 & 1 \end{bmatrix} P_K^T$$

$$\therefore P_1^T = P_1, P_2^T = P_2, P_3^T = P_3, P_4^T = P_5, P_5^T = P_4 \text{ and}$$

$$P_6^T = P_6 \text{ and Let } Q = \begin{bmatrix} 2 & 1 & 3 \\ 1 & 0 & 2 \\ 3 & 2 & 1 \end{bmatrix} \text{ and } \therefore Q^T = Q$$

$$\text{Now, } X = (P_1 Q P_1^T) + (P_2 Q P_2^T) + (P_3 Q P_3^T) + (P_4 Q P_4^T) + (P_5 Q P_5^T) + (P_6 Q P_6^T)$$

$$\text{So, } X^T = (P_1 Q P_1^T)^T + (P_2 Q P_2^T)^T + (P_3 Q P_3^T)^T + (P_4 Q P_4^T)^T + (P_5 Q P_5^T)^T + (P_6 Q P_6^T)^T$$

$$= P_1 Q P_1^T + P_2 Q P_2^T + P_3 Q P_3^T + P_4 Q P_4^T + P_5 Q P_5^T + P_6 Q P_6^T$$

[$\therefore (ABC)^T = C^T B^T A^T$ and $(A^T)^T = A$ and $Q^T = Q$]

$$\Rightarrow X^T = X$$

$\Rightarrow X$ is a symmetric matrix.

The sum of diagonal entries of $X = \text{Tr}(X)$

$$= \sum_{i=1}^6 \text{Tr}(P_i Q P_i^T)$$

$$= \sum_{i=1}^6 \text{Tr}(Q P_i^T P_i) \quad [\therefore \text{Tr}(ABC) = \text{Tr}(BCA)]$$

$$= \sum_{i=1}^6 \text{Tr}(Q I) \quad [\therefore P_i \text{'s are orthogonal matrices}]$$

$$= \sum_{i=1}^6 \text{Tr}(Q) = 6 \text{Tr}(Q) = 6 \times 3 = 18$$

Now, Let $R = \begin{bmatrix} 1 \\ 1 \\ 1 \end{bmatrix}$, then

$$XR = \sum_{K=1}^6 (P_K Q P_K^T) R = \sum_{K=1}^6 (P_K Q P_K^T R)$$

$$= \sum_{K=1}^6 (P_K Q R) \quad [\therefore P_K^T R = R]$$

$$= \sum_{K=1}^6 P_K \begin{bmatrix} 6 \\ 3 \\ 6 \end{bmatrix} = \sum_{K=1}^6 P_K \begin{bmatrix} 6 \\ 3 \\ 6 \end{bmatrix} = \begin{bmatrix} 2 & 2 & 2 \\ 2 & 2 & 2 \\ 2 & 2 & 2 \end{bmatrix} \begin{bmatrix} 6 \\ 3 \\ 6 \end{bmatrix}$$

$$\Rightarrow XR = \begin{bmatrix} 30 \\ 30 \\ 30 \end{bmatrix} \Rightarrow XR = 30R \Rightarrow X \begin{bmatrix} 1 \\ 1 \\ 1 \end{bmatrix} = 30 \begin{bmatrix} 1 \\ 1 \\ 1 \end{bmatrix}$$

$$\Rightarrow (X - 30I) R = 0 \Rightarrow |X - 30I| = 0$$

So, $(X - 30I)$ is not invertible and value of $\alpha = 30$.

Hence, options (a), (b) and (d) are correct.

12. Given, $X^T = -X, Y^T = -Y, Z^T = Z$

(a) Let $P = Y^3 Z^4 - Z^4 Y^3$

Then, $P^T = (Y^3 Z^4)^T - (Z^4 Y^3)^T$

$$= (Z^T)^4 (Y^T)^3 - (Y^T)^3 (Z^T)^4$$

$$= -Z^4 Y^3 + Y^3 Z^4 = P$$

$\therefore P$ is symmetric matrix.

(b) Let $P = X^{44} + Y^{44}$

Then, $P^T = (X^T)^{44} + (Y^T)^{44}$

$$= X^{44} + Y^{44} = P$$

$\therefore P$ is symmetric matrix.

(c) Let $P = X^4 Z^3 - Z^3 X^4$

Then, $P^T = (X^4 Z^3)^T - (Z^3 X^4)^T$

$$= (Z^T)^3 (X^T)^4 - (X^T)^4 (Z^T)^3$$

$$= Z^3 X^4 - X^4 Z^3 = -P$$

$\therefore P$ is skew-symmetric matrix.

(d) Let $P = X^{23} + Y^{23}$

Then, $P^T = (X^T)^{23} + (Y^T)^{23} = -X^{23} - Y^{23} = -P$

$\therefore P$ is skew-symmetric matrix.

13. (a) $(N^T M N)^T = N^T M^T (N^T)^T = N^T M^T N$, is symmetric if M is symmetric and skew-symmetric, if M is skew-symmetric.

(b) $(MN - NM)^T = (MN)^T - (NM)^T$

$$= NM - MN = -(MN - NM)$$

\therefore Skew-symmetric, when M and N are symmetric.

(c) $(MN)^T = N^T M^T = NM \neq MN$

\therefore Not correct.

(d) $(\text{adj } MN) = (\text{adj } N) \cdot (\text{adj } M)$

\therefore Not correct.

14. Here, $P = [p_{ij}]_{n \times n}$ with $p_{ij} = w^{i+j}$

\therefore When $n = 1$

$$P = [p_{ij}]_{1 \times 1} = [\omega^2]$$

$$\Rightarrow P^2 = [\omega^4] \neq 0$$

\therefore When $n = 2$

148 Matrices and Determinants

$$P = [p_{ij}]_{2 \times 2} = \begin{bmatrix} p_{11} & p_{12} \\ p_{21} & p_{22} \end{bmatrix} = \begin{bmatrix} \omega^2 & \omega^3 \\ \omega^3 & \omega^4 \end{bmatrix} = \begin{bmatrix} \omega^2 & 1 \\ 1 & \omega \end{bmatrix}$$

$$P^2 = \begin{bmatrix} \omega^2 & 1 \\ 1 & \omega \end{bmatrix} \begin{bmatrix} \omega^2 & 1 \\ 1 & \omega \end{bmatrix}$$

$$\Rightarrow P^2 = \begin{bmatrix} \omega^4 + 1 & \omega^2 + \omega \\ \omega^2 + \omega & 1 + \omega^2 \end{bmatrix} \neq 0$$

When $n = 3$

$$P = [p_{ij}]_{3 \times 3} = \begin{bmatrix} \omega^2 & \omega^3 & \omega^4 \\ \omega^3 & \omega^4 & \omega^5 \\ \omega^4 & \omega^5 & \omega^6 \end{bmatrix} = \begin{bmatrix} \omega^2 & 1 & \omega \\ 1 & \omega & \omega^2 \\ \omega & \omega^2 & 1 \end{bmatrix}$$

$$P^2 = \begin{bmatrix} \omega^2 & 1 & \omega \\ 1 & \omega & \omega^2 \\ \omega & \omega^2 & 1 \end{bmatrix} \begin{bmatrix} \omega^2 & 1 & \omega \\ 1 & \omega & \omega^2 \\ \omega & \omega^2 & 1 \end{bmatrix} = \begin{bmatrix} 0 & 0 & 0 \\ 0 & 0 & 0 \\ 0 & 0 & 0 \end{bmatrix} = 0$$

$\therefore P^2 = 0$, when n is a multiple of 3.

$P^2 \neq 0$, when n is not a multiple of 3.

$\Rightarrow n = 57$ is not possible.

$\therefore n = 55, 58, 56$ is possible.

15. As (a, b, c) lies on $2x + y + z = 1 \Rightarrow 2a + b + c = 1$

$$\Rightarrow 2a + 6a - 7a = 1$$

$$\Rightarrow a = 1, b = 6, c = -7$$

$$\therefore 7a + b + c = 7 + 6 - 7 = 6$$

16. If $b = 6 \Rightarrow a = 1$ and $c = -7$

$$\therefore ax^2 + bx + c = 0 \Rightarrow x^2 + 6x - 7 = 0$$

$$\Rightarrow (x + 7)(x - 1) = 0$$

$$\therefore x = 1, -7$$

$$\Rightarrow \sum_{n=0}^{\infty} \left(\frac{1}{1} - \frac{1}{7} \right)^n = 1 + \frac{6}{7} + \left(\frac{6}{7} \right)^2 + \dots + \infty = \frac{1}{1 - \frac{6}{7}}$$

$$= \frac{1}{1/7} = 7$$

17. If $a = 2, b = 12, c = -14$

$$\therefore \frac{3}{\omega^a} + \frac{1}{\omega^b} + \frac{3}{\omega^c}$$

$$\Rightarrow \frac{3}{\omega^2} + \frac{1}{\omega^{12}} + \frac{3}{\omega^{-14}} = \frac{3}{\omega^2} + 1 + 3\omega^2 = 3\omega + 1 + 3\omega^2$$

$$= 1 + 3(\omega + \omega^2) = 1 - 3 = -2$$

18. The number of matrices for which p does not divide $\text{Tr}(A) = (p-1)p^2$ of these $(p-1)^2$ are such that p divides $|A|$. The number of matrices for which p divides $\text{Tr}(A)$ and p does not divide $|A|$ are $(p-1)^2$.

$$\therefore \text{Required number} = (p-1)p^2 - (p-1)^2 + (p-1)^2$$

$$= p^3 - p^2$$

19. Trace of $A = 2a$, will be divisible by p , iff $a = 0$.

$|A| = a^2 - bc$, for $(a^2 - bc)$ to be divisible by p . There are exactly $(p-1)$ ordered pairs (b, c) for any value of a .

\therefore Required number is $(p-1)^2$.

20. Given, $A = \begin{bmatrix} a & b \\ c & a \end{bmatrix}$, $a, b, c \in \{0, 1, 2, \dots, p-1\}$

If A is skew-symmetric matrix, then $a = 0, b = -c$

$$\therefore |A| = -b^2$$

Thus, P divides $|A|$, only when $b = 0$ (i)

Again, if A is symmetric matrix, then $b = c$ and

$$|A| = a^2 - b^2$$

Thus, p divides $|A|$, if either p divides $(a-b)$ or p divides $(a+b)$.

p divides $(a-b)$, only when $a = b$,

$$\text{i.e. } a = b \in \{0, 1, 2, \dots, (p-1)\}$$

i.e. p choices

... (ii)

p divides $(a+b)$.

$\Rightarrow p$ choices, including $a = b = 0$ included in Eq. (i).

\therefore Total number of choices are $(p + p - 1) = 2p - 1$

21. Given, $A = \begin{bmatrix} a & b & c \\ b & c & a \\ c & a & b \end{bmatrix}$, $abc = 1$ and $A^T A = I$... (i)

Now, $A^T A = I$

$$\Rightarrow \begin{bmatrix} a & b & c \\ b & c & a \\ c & a & b \end{bmatrix} \begin{bmatrix} a & b & c \\ b & c & a \\ c & a & b \end{bmatrix} = \begin{bmatrix} 1 & 0 & 0 \\ 0 & 1 & 0 \\ 0 & 0 & 1 \end{bmatrix}$$

$$\Rightarrow \begin{bmatrix} a^2 + b^2 + c^2 & ab + bc + ca & ab + bc + ca \\ ab + bc + ca & a^2 + b^2 + c^2 & ab + bc + ca \\ ab + bc + ca & ab + bc + ca & a^2 + b^2 + c^2 \end{bmatrix}$$

$$= \begin{bmatrix} 1 & 0 & 0 \\ 0 & 1 & 0 \\ 0 & 0 & 1 \end{bmatrix}$$

$$\Rightarrow a^2 + b^2 + c^2 = 1 \quad \text{and} \quad ab + bc + ca = 0 \quad \dots \text{(ii)}$$

We know, $a^3 + b^3 + c^3 - 3abc$

$$= (a + b + c)(a^2 + b^2 + c^2 - ab - bc - ca)$$

$$\Rightarrow a^3 + b^3 + c^3 = (a + b + c)(1 - 0) + 3$$

[from Eqs. (i) and (ii)]

$$\therefore a^3 + b^3 + c^3 = (a + b + c) + 3 \quad \dots \text{(iii)}$$

Now, $(a + b + c)^2 = a^2 + b^2 + c^2 + 2(ab + bc + ca)$

$$= 1$$

... (iv)

From Eq. (iii), $a^3 + b^3 + c^3 = 1 + 3 \Rightarrow a^3 + b^3 + c^3 = 4$

22. Let a square matrix 'A' of order 2×2 , such that

$t_r(A) = 3$, is

$$A = \begin{bmatrix} x & y \\ z & 3-x \end{bmatrix}$$

$$\text{So, } A^2 = \begin{bmatrix} x & y \\ z & 3-x \end{bmatrix} \begin{bmatrix} x & y \\ z & 3-x \end{bmatrix}$$

$$= \begin{bmatrix} x^2 + yz & xy + 3y - xy \\ xz + 3z - xz & yz + (3-x)^2 \end{bmatrix}$$

$$\therefore A^3 = \begin{bmatrix} x^2 + yz & 3y \\ + 3z & yz + 9 + x^2 - 6x \end{bmatrix} \begin{bmatrix} x & y \\ z & 3-x \end{bmatrix}$$

$$\therefore t_r(A^3) = x^3 + xyz + 3yz + 3yz + 3yz - xyz$$

$$+ 27 - 9x + 3x^2 - x^3 - 18x + 6x^2$$

$$\begin{aligned} &= 9yz + 27 - 27x + 9x^2 = -18 && \text{(given)} \\ \Rightarrow &yz + 3 - 3x + x^2 = -2 \\ \Rightarrow &3x - x^2 - yz = 5 \\ \therefore &|A| = \begin{vmatrix} x & y \\ z & 3-x \end{vmatrix} = 3x - x^2 - yz = 5. \end{aligned}$$

23. Here, $z = \frac{-1 + i\sqrt{3}}{2} = \omega$

$$\begin{aligned} \therefore P &= \begin{bmatrix} (-\omega)^r & \omega^{2s} \\ \omega^{2s} & \omega^r \end{bmatrix} \\ P^2 &= \begin{bmatrix} (-\omega)^r & \omega^{2s} \\ \omega^{2s} & \omega^r \end{bmatrix} \begin{bmatrix} (-\omega)^r & \omega^{2s} \\ \omega^{2s} & \omega^r \end{bmatrix} \\ &= \begin{bmatrix} \omega^{2r} + \omega^{4s} & \omega^{r+2s} [(-1)^r + 1] \\ \omega^{r+2s} [(-1)^r + 1] & \omega^{4s} + \omega^{2r} \end{bmatrix} \end{aligned}$$

Given, $P^2 = -I$

$$\therefore \omega^{2r} + \omega^{4s} = -1 \text{ and } \omega^{r+2s} [(-1)^r + 1] = 0$$

Since, $r \in \{1, 2, 3\}$ and $(-1)^r + 1 = 0$

$$\Rightarrow r = \{1, 3\}$$

Also, $\omega^{2r} + \omega^{4s} = -1$

If $r = 1$, then $\omega^2 + \omega^{4s} = -1$

which is only possible, when $s = 1$.

As, $\omega^2 + \omega^4 = -1$

$$\therefore r = 1, s = 1$$

Again, if $r = 3$, then

$$\omega^6 + \omega^{4s} = -1$$

$$\Rightarrow \omega^{4s} = -2 \quad \text{[never possible]}$$

$$\therefore r \neq 3$$

$\Rightarrow (r, s) = (1, 1)$ is the only solution.

Hence, the total number of ordered pairs is 1.

Topic 2 Properties of Determinants

1. Given function

$$\begin{aligned} f(\theta) &= \begin{vmatrix} -\sin^2\theta & -1 - \sin^2\theta & 1 \\ -\cos^2\theta & -1 - \cos^2\theta & 1 \\ 12 & 10 & -2 \end{vmatrix} \\ &= 2 \begin{vmatrix} -\sin^2\theta & -1 - \sin^2\theta & 1 \\ -\cos^2\theta & -1 - \cos^2\theta & 1 \\ 6 & 5 & -1 \end{vmatrix} \end{aligned}$$

On applying

$$R_1 \rightarrow R_1 + R_3 \text{ and } R_2 \rightarrow R_2 + R_3, \text{ we get}$$

$$\begin{aligned} f(\theta) &= 2 \begin{vmatrix} 6 - \sin^2\theta & 4 - \sin^2\theta & 0 \\ 6 - \cos^2\theta & 4 - \cos^2\theta & 0 \\ 6 & 5 & -1 \end{vmatrix} \\ &= 2(-1)[(6 - \sin^2\theta)(4 - \cos^2\theta) - (4 - \sin^2\theta)(6 - \cos^2\theta)] \\ &= -2[24 - 6\cos^2\theta - 4\sin^2\theta + \sin^2\theta\cos^2\theta - \\ &\quad 24 + 4\cos^2\theta + 6\sin^2\theta - \sin^2\theta\cos^2\theta] \\ &= -2[-2\cos^2\theta + 2\sin^2\theta] = 4\cos 2\theta \end{aligned}$$

$$\text{As } \theta \in \left[\frac{\pi}{4}, \frac{\pi}{2}\right] \Rightarrow 2\theta \in \left[\frac{\pi}{2}, \pi\right]$$

$$\therefore f(\theta)_{\text{minimum}} = f\left(\frac{\pi}{2}\right) = -4 = m$$

$$\text{and } f(\theta)_{\text{maximum}} = f\left(\frac{\pi}{4}\right) = 0 = M$$

\therefore The ordered pair (m, M) is $(-4, 0)$.

2. Let $\Delta = \begin{vmatrix} 1 + \cos^2\theta & \sin^2\theta & 4\cos 6\theta \\ \cos^2\theta & 1 + \sin^2\theta & 4\cos 6\theta \\ \cos^2\theta & \sin^2\theta & 1 + 4\cos 6\theta \end{vmatrix} = 0$

Applying $C_1 \rightarrow C_1 + C_2$, we get

$$\Delta = \begin{vmatrix} 2 & \sin^2\theta & 4\cos 6\theta \\ 2 & 1 + \sin^2\theta & 4\cos 6\theta \\ 1 & \sin^2\theta & 1 + 4\cos 6\theta \end{vmatrix} = 0$$

Applying $R_1 \rightarrow R_1 - 2R_3$ and $R_2 \rightarrow R_2 - 2R_3$, we get

$$\Delta = \begin{vmatrix} 0 & -\sin^2\theta & -2 - 4\cos 6\theta \\ 0 & 1 - \sin^2\theta & -2 - 4\cos 6\theta \\ 1 & \sin^2\theta & 1 + 4\cos 6\theta \end{vmatrix} = 0$$

On expanding w.r.t. C_1 , we get

$$\Rightarrow \sin^2\theta (2 + 4\cos 6\theta) + (2 + 4\cos 6\theta) (1 - \sin^2\theta) = 0$$

$$\Rightarrow 2 + 4\cos 6\theta = 0 \Rightarrow \cos 6\theta = -\frac{1}{2} = \cos \frac{2\pi}{3}$$

$$\Rightarrow 6\theta = \frac{2\pi}{3} \Rightarrow \theta = \frac{\pi}{9} \quad \left[\because \theta \in \left(0, \frac{\pi}{3}\right) \right]$$

3. Given equation $\begin{vmatrix} x & -6 & -1 \\ 2 & -3x & x-3 \\ -3 & 2x & x+2 \end{vmatrix} = 0$

On expansion of determinant along R_1 , we get

$$x[(-3x)(x+2) - 2x(x-3)] + 6[2(x+2) + 3(x-3)]$$

$$- 1[2(2x) - (-3x)(-3)] = 0$$

$$\Rightarrow x[-3x^2 - 6x - 2x^2 + 6x] + 6[2x + 4 + 3x - 9]$$

$$- 1[4x - 9x] = 0$$

$$\Rightarrow x(-5x^2) + 6(5x - 5) - 1(-5x) = 0$$

$$\Rightarrow -5x^3 + 30x - 30 + 5x = 0$$

$$\Rightarrow 5x^3 - 35x + 30 = 0 \Rightarrow x^3 - 7x + 6 = 0.$$

Since all roots are real

$$\therefore \text{Sum of roots} = -\frac{\text{coefficient of } x^2}{\text{coefficient of } x^3} = 0$$

4. Given determinants are

$$\Delta_1 = \begin{vmatrix} x & \sin\theta & \cos\theta \\ -\sin\theta & -x & 1 \\ \cos\theta & 1 & x \end{vmatrix}$$

$$= -x^3 + \sin\theta\cos\theta - \sin\theta\cos\theta + x\cos^2\theta - x + x\sin^2\theta = -x^3$$

$$\text{and } \Delta_2 = \begin{vmatrix} x & \sin 2\theta & \cos 2\theta \\ -\sin 2\theta & -x & 1 \\ \cos 2\theta & 1 & x \end{vmatrix}, x \neq 0$$

$$= -x^3 \text{ (similarly as } \Delta_1)$$

So, according to options, we get $\Delta_1 + \Delta_2 = -2x^3$

150 Matrices and Determinants

5. Given

$$\begin{aligned}
 &\begin{bmatrix} 1 & 1 \\ 0 & 1 \end{bmatrix} \begin{bmatrix} 1 & 2 \\ 0 & 1 \end{bmatrix} \begin{bmatrix} 1 & 3 \\ 0 & 1 \end{bmatrix} \cdots \begin{bmatrix} 1 & n-1 \\ 0 & 1 \end{bmatrix} = \begin{bmatrix} 1 & 78 \\ 0 & 1 \end{bmatrix} \\
 \therefore &\begin{bmatrix} 1 & 1 \\ 0 & 1 \end{bmatrix} \begin{bmatrix} 1 & 2 \\ 0 & 1 \end{bmatrix} = \begin{bmatrix} 1 & 2+1 \\ 0 & 1 \end{bmatrix} \\
 &\begin{bmatrix} 1 & 2+1 \\ 0 & 1 \end{bmatrix} \begin{bmatrix} 1 & 3 \\ 0 & 1 \end{bmatrix} = \begin{bmatrix} 1 & 3+2+1 \\ 0 & 1 \end{bmatrix} \\
 &\vdots \quad \quad \quad \vdots \quad \quad \quad \vdots \\
 \therefore &\begin{bmatrix} 1 & 1 \\ 0 & 1 \end{bmatrix} \begin{bmatrix} 1 & 2 \\ 0 & 1 \end{bmatrix} \begin{bmatrix} 1 & 3 \\ 0 & 1 \end{bmatrix} \cdots \begin{bmatrix} 1 & n-1 \\ 0 & 1 \end{bmatrix} \\
 &= \begin{bmatrix} 1 & (n-1)+(n-2)+\dots+3+2+1 \\ 0 & 1 \end{bmatrix} \\
 &= \begin{bmatrix} 1 & \frac{n(n-1)}{2} \\ 0 & 1 \end{bmatrix} = \begin{bmatrix} 1 & 78 \\ 0 & 1 \end{bmatrix}
 \end{aligned}$$

Since, both matrices are equal, so equating corresponding element, we get

$$\frac{n(n-1)}{2} = 78 \Rightarrow n(n-1) = 156 = 13 \times 12 = 13(13-1)$$

$$\Rightarrow n = 13$$

So, $A = \begin{bmatrix} 1 & 13 \\ 0 & 1 \end{bmatrix} = A^{-1} = \begin{bmatrix} 1 & -13 \\ 0 & 1 \end{bmatrix}$

[∵ if $|A|=1$ and $A = \begin{bmatrix} a & b \\ c & d \end{bmatrix}$, then $A^{-1} = \begin{bmatrix} d & -b \\ -c & a \end{bmatrix}$]

6. Given, quadratic equation is $x^2 + x + 1 = 0$ having roots α, β .

Then, $\alpha + \beta = -1$ and $\alpha\beta = 1$

Now, given determinant

$$\Delta = \begin{vmatrix} y+1 & \alpha & \beta \\ \alpha & y+\beta & 1 \\ \beta & 1 & y+\alpha \end{vmatrix}$$

On applying $R_1 \rightarrow R_1 + R_2 + R_3$, we get

$$\begin{aligned}
 \Delta &= \begin{vmatrix} y+1+\alpha+\beta & y+1+\alpha+\beta & y+1+\alpha+\beta \\ \alpha & y+\beta & 1 \\ \beta & 1 & y+\alpha \end{vmatrix} \\
 &= \begin{vmatrix} y & y & y \\ \alpha & y+\beta & 1 \\ \beta & 1 & y+\alpha \end{vmatrix} \quad [\because \alpha+\beta=-1]
 \end{aligned}$$

On applying $C_2 \rightarrow C_2 - C_1$ and $C_3 \rightarrow C_3 - C_1$, we get

$$\begin{aligned}
 \Delta &= \begin{vmatrix} y & 0 & 0 \\ \alpha & y+\beta-\alpha & 1-\alpha \\ \beta & 1-\beta & y+\alpha-\beta \end{vmatrix} \\
 &= y[(y+(\beta-\alpha))(y-(\beta-\alpha))-(1-\alpha)(1-\beta)] \\
 &\quad \quad \quad [\text{expanding along } R_1] \\
 &= y[y^2-(\beta-\alpha)^2-(1-\alpha-\beta+\alpha\beta)] \\
 &= y[y^2-\beta^2-\alpha^2+2\alpha\beta-1+(\alpha+\beta)-\alpha\beta]
 \end{aligned}$$

$$\begin{aligned}
 &= y[y^2-(\alpha+\beta)^2+2\alpha\beta+2\alpha\beta-1+(\alpha+\beta)-\alpha\beta] \\
 &= y[y^2-1+3-1-1] = y^3 \quad [\because \alpha+\beta=-1 \text{ and } \alpha\beta=1]
 \end{aligned}$$

7. Given, matrix $A = \begin{bmatrix} 1 & 1 & 1 \\ 2 & b & c \\ 4 & b^2 & c^2 \end{bmatrix}$, so

$$\det(A) = \begin{vmatrix} 1 & 1 & 1 \\ 2 & b & c \\ 4 & b^2 & c^2 \end{vmatrix}$$

On applying, $C_2 \rightarrow C_2 - C_1$ and $C_3 \rightarrow C_3 - C_1$,

$$\begin{aligned}
 \text{we get } \det(A) &= \begin{vmatrix} 1 & 0 & 0 \\ 2 & b-2 & c-2 \\ 4 & b^2-4 & c^2-4 \end{vmatrix} = \begin{vmatrix} b-2 & c-2 \\ b^2-4 & c^2-4 \end{vmatrix} \\
 &= \begin{vmatrix} b-2 & c-2 \\ (b-2)(b+2) & (c-2)(c+2) \end{vmatrix} \\
 &= (b-2)(c-2) \begin{vmatrix} 1 & 1 \\ b+2 & c+2 \end{vmatrix}
 \end{aligned}$$

[taking common $(b-2)$ from C_1 and $(c-2)$ from C_2]

$$= (b-2)(c-2)(c-b)$$

Since, 2, b and c are in AP, if assume common difference of AP is d, then

$$b = 2 + d \text{ and } c = 2 + 2d$$

So, $|A| = d(2d)d = 2d^3 \in [2, 16]$ [given]

$$\Rightarrow d^3 \in [1, 8] \Rightarrow d \in [1, 2]$$

$$\therefore 2 + 2d \in [2 + 2, 2 + 4]$$

$$= [4, 6] \Rightarrow c \in [4, 6]$$

8. Given matrix $A = \begin{bmatrix} 1 & \sin \theta & 1 \\ -\sin \theta & 1 & \sin \theta \\ -1 & -\sin \theta & 1 \end{bmatrix}$

$$\Rightarrow \det(A) = |A| = \begin{vmatrix} 1 & \sin \theta & 1 \\ -\sin \theta & 1 & \sin \theta \\ -1 & -\sin \theta & 1 \end{vmatrix}$$

$$= 1(1 + \sin^2 \theta) - \sin \theta(-\sin \theta + \sin \theta) + 1(\sin^2 \theta + 1)$$

$$\Rightarrow |A| = 2(1 + \sin^2 \theta) \quad \dots (i)$$

As we know that, for $\theta \in \left(\frac{3\pi}{4}, \frac{5\pi}{4}\right)$

$$\sin \theta \in \left(-\frac{1}{\sqrt{2}}, \frac{1}{\sqrt{2}}\right) \Rightarrow \sin^2 \theta \in \left[0, \frac{1}{2}\right)$$

$$\Rightarrow 1 + \sin^2 \theta \in \left[0 + 1, \frac{1}{2} + 1\right) \Rightarrow 1 + \sin^2 \theta \in \left[1, \frac{3}{2}\right)$$

$$\Rightarrow 2(1 + \sin^2 \theta) \in [2, 3) \Rightarrow |A| \in [2, 3) \subset \left(\frac{3}{2}, 3\right]$$

9. Let $\Delta = \begin{vmatrix} a-b-c & 2a & 2a \\ 2b & b-c-a & 2b \\ 2c & 2c & c-a-b \end{vmatrix}$

Applying $R_1 \rightarrow R_1 + R_2 + R_3$, we get

$$\Delta = \begin{vmatrix} a+b+c & a+b+c & a+b+c \\ 2b & b-c-a & 2b \\ 2c & 2c & c-a-b \end{vmatrix}$$

$$= (a + b + c) \begin{vmatrix} 1 & 1 & 1 \\ 2b & b - c - a & 2b \\ 2c & 2c & c - a - b \end{vmatrix}$$

(taking common $(a + b + c)$ from R_1)

Applying $C_2 \rightarrow C_2 - C_1$ and $C_3 \rightarrow C_3 - C_1$, we get

$$\Delta = (a + b + c) \begin{vmatrix} 1 & 0 & 0 \\ 2b & -(a + b + c) & 0 \\ 2c & 0 & -(a + b + c) \end{vmatrix}$$

Now, expanding along R_1 , we get

$$\begin{aligned} \Delta &= (a + b + c) 1 \cdot \{(a + b + c)^2 - 0\} \\ &= (a + b + c)^3 = (a + b + c)(x + a + b + c)^2 \quad (\text{given}) \\ \Rightarrow (x + a + b + c)^2 &= (a + b + c)^2 \\ \Rightarrow x + a + b + c &= \pm (a + b + c) \\ \Rightarrow x &= -2(a + b + c) \quad [\because x \neq 0] \end{aligned}$$

10. Given,
$$\begin{vmatrix} \log_e a_1^r a_2^k & \log_e a_2^r a_3^k & \log_e a_3^r a_4^k \\ \log_e a_4^r a_5^k & \log_e a_5^r a_6^k & \log_e a_6^r a_7^k \\ \log_e a_7^r a_8^k & \log_e a_8^r a_9^k & \log_e a_9^r a_{10}^k \end{vmatrix} = 0$$

On applying elementary operations

$C_2 \rightarrow C_2 - C_1$ and $C_3 \rightarrow C_3 - C_1$, we get

$$\begin{vmatrix} \log_e a_1^r a_2^k & \log_e a_2^r a_3^k - \log_e a_1^r a_2^k & \log_e a_3^r a_4^k - \log_e a_1^r a_2^k \\ \log_e a_4^r a_5^k & \log_e a_5^r a_6^k - \log_e a_4^r a_5^k & \log_e a_6^r a_7^k - \log_e a_4^r a_5^k \\ \log_e a_7^r a_8^k & \log_e a_8^r a_9^k - \log_e a_7^r a_8^k & \log_e a_9^r a_{10}^k - \log_e a_7^r a_8^k \end{vmatrix} = 0$$

$$\Rightarrow \begin{vmatrix} \log_e a_1^r a_2^k & \log_e \left(\frac{a_2^r a_3^k}{a_1^r a_2^k} \right) & \log_e \left(\frac{a_3^r a_4^k}{a_1^r a_2^k} \right) \\ \log_e a_4^r a_5^k & \log_e \left(\frac{a_5^r a_6^k}{a_4^r a_5^k} \right) & \log_e \left(\frac{a_6^r a_7^k}{a_4^r a_5^k} \right) \\ \log_e a_7^r a_8^k & \log_e \left(\frac{a_8^r a_9^k}{a_7^r a_8^k} \right) & \log_e \left(\frac{a_9^r a_{10}^k}{a_7^r a_8^k} \right) \end{vmatrix} = 0$$

$$\left[\because \log_e m - \log_e n = \log_e \left(\frac{m}{n} \right) \right]$$

$[\because a_1, a_2, a_3, \dots, a_{10}$ are in GP, therefore put $a_1 = a, a_2 = aR, a_3 = aR^2, \dots, a_{10} = aR^9]$

$$\Rightarrow \begin{vmatrix} \log_e a^{r+k} R^k & \log_e \left(\frac{a^{r+k} R^{2k}}{a^{r+k} R^k} \right) \\ \log_e a^{r+k} R^{3r+4k} & \log_e \left(\frac{a^{r+k} R^{4r+5k}}{a^{r+k} R^{3r+4k}} \right) \\ \log_e a^{r+k} R^{6r+7k} & \log_e \left(\frac{a^{r+k} R^{7r+8k}}{a^{r+k} R^{6r+7k}} \right) \\ \log_e \left(\frac{a^{r+k} R^{2r+3k}}{a^{r+k} R^k} \right) \\ \log_e \left(\frac{a^{r+k} R^{5r+6k}}{a^{r+k} R^{3r+4k}} \right) \\ \log_e \left(\frac{a^{r+k} R^{8r+9k}}{a^{r+k} R^{6r+7k}} \right) \end{vmatrix} = 0$$

$$\Rightarrow \begin{vmatrix} \log_e (a^{r+k} R^k) & \log_e R^{r+k} & \log_e R^{2r+2k} \\ \log_e a^{r+k} R^{3r+4k} & \log_e R^{r+k} & \log_e R^{2r+2k} \\ \log_e a^{r+k} R^{6r+7k} & \log_e R^{r+k} & \log_e R^{2r+2k} \end{vmatrix} = 0$$

$$\Rightarrow \begin{vmatrix} \log_e (a^{r+k} R^k) & \log_e R^{r+k} & 2 \log_e R^{r+k} \\ \log_e (a^{r+k} R^{3r+4k}) & \log_e R^{r+k} & 2 \log_e R^{r+k} \\ \log_e (a^{r+k} R^{6r+7k}) & \log_e R^{r+k} & 2 \log_e R^{r+k} \end{vmatrix} = 0$$

$[\because \log m^n = n \log m$ and here

$$\log_e R^{2r+2k} = \log_e R^{2(r+k)} = 2 \log_e R^{r+k}]$$

\therefore Column C_2 and C_3 are proportional,

So, value of determinant will be zero for any value of $(r, k), r, k \in N$.

\therefore Set 'S' has infinitely many elements.

11. Given matrix, $A = \begin{bmatrix} 2 & b & 1 \\ b & b^2 + 1 & b \\ 1 & b & 2 \end{bmatrix}, b > 0$

So, $\det(A) = |A| = \begin{vmatrix} 2 & b & 1 \\ b & b^2 + 1 & b \\ 1 & b & 2 \end{vmatrix}$

$$= 2[2(b^2 + 1) - b^2] - b(2b - b) + 1(b^2 - b^2 - 1)$$

$$= 2[2b^2 + 2 - b^2] - b^2 - 1$$

$$= 2b^2 + 4 - b^2 - 1 = b^2 + 3$$

$$\Rightarrow \frac{\det(A)}{b} = \frac{b^2 + 3}{b} = b + \frac{3}{b}$$

Now, by AM \geq GM, we get

$$\frac{b + \frac{3}{b}}{2} \geq \left(b \times \frac{3}{b} \right)^{1/2} \quad \{\because b > 0\}$$

$$\Rightarrow b + \frac{3}{b} \geq 2\sqrt{3}$$

So, minimum value of $\frac{\det(A)}{b} = 2\sqrt{3}$

12. Given,

$$A = \begin{bmatrix} -2 & 4 + d & (\sin \theta) - 2 \\ 1 & (\sin \theta) + 2 & d \\ 5 & (2 \sin \theta) - d & (-\sin \theta) + 2 + 2d \end{bmatrix}$$

$$\therefore |A| = \begin{vmatrix} -2 & 4 + d & (\sin \theta) - 2 \\ 1 & (\sin \theta) + 2 & d \\ 5 & (2 \sin \theta) - d & (-\sin \theta) + 2 + 2d \end{vmatrix}$$

$$= \begin{vmatrix} -2 & 4 + d & (\sin \theta) - 2 \\ 1 & (\sin \theta) + 2 & d \\ 1 & 0 & 0 \end{vmatrix}$$

$(R_3 \rightarrow R_3 - 2R_2 + R_1)$

$$= 1 [(4 + d)d - (\sin \theta + 2)(\sin \theta - 2)]$$

$(\text{expanding along } R_3)$

$$= (d^2 + 4d - \sin^2 \theta + 4)$$

$$= (d^2 + 4d + 4) - \sin^2 \theta$$

$$= (d + 2)^2 - \sin^2 \theta$$

Note that $|A|$ will be minimum if $\sin^2 \theta$ is maximum i.e. if $\sin^2 \theta$ takes value 1.

$$\therefore |A|_{\min} = 8,$$

152 Matrices and Determinants

$$\begin{aligned} \text{therefore } (d+2)^2 - 1 &= 8 \\ \Rightarrow (d+2)^2 &= 9 \\ \Rightarrow d+2 &= \pm 3 \\ \Rightarrow d &= 1, -5 \end{aligned}$$

13. Given,

$$\begin{vmatrix} x-4 & 2x & 2x \\ 2x & x-4 & 2x \\ 2x & 2x & x-4 \end{vmatrix} = (A+Bx)(x-A)^2$$

\Rightarrow Apply $C_1 \rightarrow C_1 + C_2 + C_3$

$$\begin{vmatrix} 5x-4 & 2x & 2x \\ 5x-4 & x-4 & 2x \\ 5x-4 & 2x & x-4 \end{vmatrix} = (A+Bx)(x-A)^2$$

Taking common $(5x-4)$ from C_1 , we get

$$(5x-4) \begin{vmatrix} 1 & 2x & 2x \\ 1 & x-4 & 2x \\ 1 & 2x & x-4 \end{vmatrix} = (A+Bx)(x-A)^2$$

Apply $R_2 \rightarrow R_2 - R_1$ and $R_3 \rightarrow R_3 - R_1$

$$\therefore (5x-4) \begin{vmatrix} 1 & 2x & 0 \\ 0 & -x-4 & 0 \\ 0 & 0 & -x-4 \end{vmatrix} = (A+Bx)(x-A)^2$$

Expanding along C_1 , we get

$$(5x-4)(x+4)^2 = (A+Bx)(x-A)^2$$

Equating, we get, $A = -4$ and $B = 5$

14. Given, $2\omega + 1 = z$

$$\Rightarrow 2\omega + 1 = \sqrt{-3} \quad [:\cdot z = \sqrt{-3}]$$

$$\Rightarrow \omega = \frac{-1 + \sqrt{3}i}{2}$$

Since, ω is cube root of unity.

$$\therefore \omega^2 = \frac{-1 - \sqrt{3}i}{2} \text{ and } \omega^{3n} = 1$$

$$\text{Now, } \begin{vmatrix} 1 & 1 & 1 \\ 1 & -\omega^2 - 1 & \omega^2 \\ 1 & \omega^2 & \omega^7 \end{vmatrix} = 3k$$

$$\Rightarrow \begin{vmatrix} 1 & 1 & 1 \\ 1 & \omega & \omega^2 \\ 1 & \omega^2 & \omega \end{vmatrix} = 3k$$

$$[:\cdot 1 + \omega + \omega^2 = 0 \text{ and } \omega^7 = (\omega^3)^2 \cdot \omega = \omega]$$

On applying $R_1 \rightarrow R_1 + R_2 + R_3$, we get

$$\begin{vmatrix} 3 & 1 + \omega + \omega^2 & 1 + \omega + \omega^2 \\ 1 & \omega & \omega^2 \\ 1 & \omega^2 & \omega \end{vmatrix} = 3k$$

$$\Rightarrow \begin{vmatrix} 3 & 0 & 0 \\ 1 & \omega & \omega^2 \\ 1 & \omega^2 & \omega \end{vmatrix} = 3k$$

$$\Rightarrow 3(\omega^2 - \omega^4) = 3k$$

$$\Rightarrow (\omega^2 - \omega) = k$$

$$\therefore k = \left(\frac{-1 - \sqrt{3}i}{2} \right) - \left(\frac{-1 + \sqrt{3}i}{2} \right) = -\sqrt{3}i = -z$$

15. **PLAN** Use the property that, two determinants can be multiplied column-to-row or row-to-column, to write the given determinant as the product of two determinants and then expand.

$$\text{Given, } f(n) = \alpha^n + \beta^n, \quad f(1) = \alpha + \beta, \quad f(2) = \alpha^2 + \beta^2, \\ f(3) = \alpha^3 + \beta^3, \quad f(4) = \alpha^4 + \beta^4$$

$$\text{Let } \Delta = \begin{vmatrix} 3 & 1 + f(1) & 1 + f(2) \\ 1 + f(1) & 1 + f(2) & 1 + f(3) \\ 1 + f(2) & 1 + f(3) & 1 + f(4) \end{vmatrix}$$

$$\Rightarrow \Delta = \begin{vmatrix} 3 & 1 + \alpha + \beta & 1 + \alpha^2 + \beta^2 \\ 1 + \alpha + \beta & 1 + \alpha^2 + \beta^2 & 1 + \alpha^3 + \beta^3 \\ 1 + \alpha^2 + \beta^2 & 1 + \alpha^3 + \beta^3 & 1 + \alpha^4 + \beta^4 \end{vmatrix} \\ = \begin{vmatrix} 1 \cdot 1 + 1 \cdot 1 + 1 \cdot 1 & 1 \cdot 1 + 1 \cdot \alpha + 1 \cdot \beta \\ 1 \cdot 1 + 1 \cdot \alpha + 1 \cdot \beta & 1 \cdot 1 + \alpha \cdot \alpha + \beta \cdot \beta \\ 1 \cdot 1 + 1 \cdot \alpha^2 + 1 \cdot \beta^2 & 1 \cdot 1 + \alpha^2 \cdot \alpha + \beta^2 \cdot \beta \\ & 1 \cdot 1 + 1 \cdot \alpha^2 + 1 \cdot \beta^2 \\ & 1 \cdot 1 + \alpha \cdot \alpha^2 + \beta \cdot \beta^2 \\ & 1 \cdot 1 + \alpha^2 \cdot \alpha^2 + \beta^2 \cdot \beta^2 \end{vmatrix} \\ = \begin{vmatrix} 1 & 1 & 1 \\ 1 & \alpha & \beta \\ 1 & \alpha^2 & \beta^2 \end{vmatrix} \begin{vmatrix} 1 & 1 & 1 \\ 1 & \alpha & \beta \\ 1 & \alpha^2 & \beta^2 \end{vmatrix} = \begin{vmatrix} 1 & 1 & 1 \\ 1 & \alpha & \beta \\ 1 & \alpha^2 & \beta^2 \end{vmatrix}^2$$

On expanding, we get $\Delta = (1 - \alpha)^2(1 - \beta)^2(\alpha - \beta)^2$

But given, $\Delta = K(1 - \alpha)^2(1 - \beta)^2(\alpha - \beta)^2$

$$\text{Hence, } K(1 - \alpha)^2(1 - \beta)^2(\alpha - \beta)^2 = (1 - \alpha)^2(1 - \beta)^2(\alpha - \beta)^2 \\ \therefore K = 1$$

16. **PLAN** It is a simple question on scalar multiplication, i.e.

$$\begin{vmatrix} ka_1 & ka_2 & ka_3 \\ b_1 & b_2 & b_3 \\ c_1 & c_2 & c_3 \end{vmatrix} = k \begin{vmatrix} a_1 & a_2 & a_3 \\ b_1 & b_2 & b_3 \\ c_1 & c_2 & c_3 \end{vmatrix}$$

Description of Situation Construction of matrix,

$$\text{i.e. if } a = [a_{ij}]_{3 \times 3} = \begin{bmatrix} a_{11} & a_{12} & a_{13} \\ a_{21} & a_{22} & a_{23} \\ a_{31} & a_{32} & a_{33} \end{bmatrix}$$

$$\text{Here, } P = [a_{ij}]_{3 \times 3} = \begin{bmatrix} a_{11} & a_{12} & a_{13} \\ a_{21} & a_{22} & a_{23} \\ a_{31} & a_{32} & a_{33} \end{bmatrix}$$

$$Q = [b_{ij}]_{3 \times 3} = \begin{bmatrix} b_{11} & b_{12} & b_{13} \\ b_{21} & b_{22} & b_{23} \\ b_{31} & b_{32} & b_{33} \end{bmatrix}$$

where, $b_{ij} = 2^{i+j} a_{ij}$

$$\therefore |Q| = \begin{vmatrix} 4a_{11} & 8a_{12} & 16a_{13} \\ 8a_{21} & 16a_{22} & 32a_{23} \\ 16a_{31} & 32a_{32} & 64a_{33} \end{vmatrix}$$

$$= 4 \times 8 \times 16 \begin{vmatrix} a_{11} & a_{12} & a_{13} \\ 2a_{21} & 2a_{22} & 2a_{23} \\ 4a_{31} & 4a_{32} & 4a_{33} \end{vmatrix}$$

$$= 2^9 \times 2 \times 4 \begin{vmatrix} a_{11} & a_{12} & a_{13} \\ a_{21} & a_{22} & a_{23} \\ a_{31} & a_{32} & a_{33} \end{vmatrix}$$

$$= 2^{12} \cdot |P| = 2^{12} \cdot 2 = 2^{13}$$

17. We know, $|A^n| = |A|^n$
 Since, $|A^3| = 125 \Rightarrow |A|^3 = 125$
 $\Rightarrow \begin{vmatrix} \alpha & 2 \\ 2 & \alpha \end{vmatrix} = 5 \Rightarrow \alpha^2 - 4 = 5 \Rightarrow \alpha = \pm 3$

18. Given, $\begin{vmatrix} \sin x & \cos x & \cos x \\ \cos x & \sin x & \cos x \\ \cos x & \cos x & \sin x \end{vmatrix} = 0$
 Applying $C_1 \rightarrow C_1 + C_2 + C_3$
 $= \begin{vmatrix} \sin x + 2 \cos x & \cos x & \cos x \\ \sin x + 2 \cos x & \sin x & \cos x \\ \sin x + 2 \cos x & \cos x & \sin x \end{vmatrix}$
 $= (2 \cos x + \sin x) \begin{vmatrix} 1 & \cos x & \cos x \\ 1 & \sin x & \cos x \\ 1 & \cos x & \sin x \end{vmatrix} = 0$

Applying $R_2 \rightarrow R_2 - R_1, R_3 \rightarrow R_3 - R_1$
 $\Rightarrow (2 \cos x + \sin x) \begin{vmatrix} 1 & \cos x & \cos x \\ 0 & \sin x - \cos x & 0 \\ 0 & 0 & \sin x - \cos x \end{vmatrix} = 0$
 $\Rightarrow (2 \cos x + \sin x) (\sin x - \cos x)^2 = 0$
 $\Rightarrow 2 \cos x + \sin x = 0$ or $\sin x - \cos x = 0$
 $\Rightarrow 2 \cos x = -\sin x$ or $\sin x = \cos x$
 $\Rightarrow \cot x = -1/2$ gives no solution in $-\frac{\pi}{4} \leq x \leq \frac{\pi}{4}$
 and $\sin x = \cos x \Rightarrow \tan x = 1 \Rightarrow x = \pi/4$

19. Given,
 $f(x) = \begin{vmatrix} 1 & x & x+1 \\ 2x & x(x-1) & (x+1)x \\ 3x(x-1) & x(x-1)(x-2) & (x+1)x(x-1) \end{vmatrix}$
 Applying $C_3 \rightarrow C_3 - (C_1 + C_2)$
 $= \begin{vmatrix} 1 & x & 0 \\ 2x & x(x-1) & 0 \\ 3x(x-1) & x(x-1)(x-2) & 0 \end{vmatrix} = 0$
 $\therefore f(x) = 0 \Rightarrow f(100) = 0$

20. Let $\Delta = \begin{vmatrix} 1 & a & a^2 \\ \cos(p-d)x & \cos px & \cos(p+d)x \\ \sin(p-d)x & \sin px & \sin(p+d)x \end{vmatrix}$
 Applying $C_1 \rightarrow C_1 + C_3$
 $\Rightarrow \Delta = \begin{vmatrix} 1+a^2 & a & a^2 \\ \cos(p-d)x + \cos(p+d)x & \cos px & \cos(p+d)x \\ \sin(p-d)x + \sin(p+d)x & \sin px & \sin(p+d)x \end{vmatrix}$
 $\Rightarrow \Delta = \begin{vmatrix} 1+a^2 & a & a^2 \\ 2 \cos px \cos dx & \cos px & \cos(p+d)x \\ 2 \sin px \cos dx & \sin px & \sin(p+d)x \end{vmatrix}$
 Applying $C_1 \rightarrow C_1 - 2 \cos dx C_2$
 $\Rightarrow \Delta = \begin{vmatrix} 1+a^2 - 2a \cos dx & a & a^2 \\ 0 & \cos px & \cos(p+d)x \\ 0 & \sin px & \sin(p+d)x \end{vmatrix}$
 $\Rightarrow \Delta = (1+a^2 - 2a \cos dx) [\sin(p+d)x \cos px - \sin px \cos(p+d)x]$
 $\Rightarrow \Delta = (1+a^2 - 2a \cos dx) \sin dx$
 which is independent of p .

21. Given, $\begin{vmatrix} xp+y & x & y \\ yp+z & y & z \\ 0 & xp+y & yp+z \end{vmatrix} = 0$
 Applying $C_1 \rightarrow C_1 - (p C_2 + C_3)$
 $\Rightarrow \begin{vmatrix} 0 & x & y \\ 0 & y & z \\ -(xp^2 + yp + yp + z) & xp+y & yp+z \end{vmatrix} = 0$
 $\Rightarrow -(xp^2 + 2yp + z)(xz - y^2) = 0$
 \therefore Either $xp^2 + 2yp + z = 0$ or $y^2 = xz$
 $\Rightarrow x, y, z$ are in GP.

22. Since, A is the determinant of order 3 with entries 0 or 1 only.

Also, B is the subset of A consisting of all determinants with value 1.

[since, if we interchange any two rows or columns, then among themselves sign changes]

Given, C is the subset having determinant with value -1 .

$\therefore B$ has as many elements as C .

23. For a matrix to be square of other matrix its determinant should be positive.

(a) and (c) \rightarrow Correct, (b) and (d) \rightarrow Incorrect

24. Given determinant could be expressed as product of two determinants.

i.e. $\begin{vmatrix} (1+\alpha)^2 & (1+2\alpha)^2 & (1+3\alpha)^2 \\ (2+\alpha)^2 & (2+2\alpha)^2 & (2+3\alpha)^2 \\ (3+\alpha)^2 & (3+2\alpha)^2 & (3+3\alpha)^2 \end{vmatrix} = -648 \alpha$
 $= \begin{vmatrix} 1+2\alpha+\alpha^2 & 1+4\alpha+4\alpha^2 & 1+6\alpha+9\alpha^2 \\ 4+4\alpha+\alpha^2 & 4+8\alpha+4\alpha^2 & 4+12\alpha+9\alpha^2 \\ 9+6\alpha+\alpha^2 & 9+12\alpha+4\alpha^2 & 9+18\alpha+9\alpha^2 \end{vmatrix}$
 $= -648 \alpha$

$\Rightarrow \begin{vmatrix} 1 & \alpha & \alpha^2 \\ 4 & 2\alpha & \alpha^2 \\ 9 & 3\alpha & \alpha^2 \end{vmatrix} \cdot \begin{vmatrix} 1 & 1 & 1 \\ 2 & 4 & 6 \\ 1 & 4 & 9 \end{vmatrix} = -648 \alpha$

$\Rightarrow \alpha^3 \begin{vmatrix} 1 & 1 & 1 \\ 4 & 2 & 1 \\ 9 & 3 & 1 \end{vmatrix} \cdot \begin{vmatrix} 1 & 1 & 1 \\ 2 & 4 & 6 \\ 1 & 4 & 9 \end{vmatrix} = -648 \alpha$
 $\Rightarrow -8\alpha^3 = -648\alpha \Rightarrow \alpha^3 - 81\alpha = 0$
 $\Rightarrow \alpha(\alpha^2 - 81) = 0$
 $\therefore \alpha = 0, \pm 9$

25. PLAN (i) If A and B are two non-zero matrices and $AB = BA$, then $(A-B)(A+B) = A^2 - B^2$.

(ii) The determinant of the product of the matrices is equal to product of their individual determinants, i.e. $|AB| = |A||B|$.

Given, $M^2 = N^4 \Rightarrow M^2 - N^4 = 0$
 $\Rightarrow (M - N^2)(M + N^2) = 0$ [as $MN = NM$]
 Also, $M \neq N^2$
 $\Rightarrow M + N^2 = 0$

154 Matrices and Determinants

$$\Rightarrow \det(M + N^2) = 0$$

$$\begin{aligned} \text{Also, } \det(M^2 + MN^2) &= (\det M) (\det M + N^2) \\ &= (\det M) (0) = 0 \end{aligned}$$

$$\text{As, } \det(M^2 + MN^2) = 0$$

Thus, there exists a non-zero matrix U such that $(M^2 + MN^2)U = 0$

$$26. \text{ Given, } \begin{vmatrix} a & b & a\alpha + b \\ b & c & b\alpha + c \\ a\alpha + b & b\alpha + c & 0 \end{vmatrix} = 0$$

Applying $C_3 \rightarrow C_3 - (\alpha C_1 + C_2)$

$$\begin{vmatrix} a & b & 0 \\ b & c & 0 \\ a\alpha + b & b\alpha + c & -(a\alpha^2 + 2b\alpha + c) \end{vmatrix} = 0$$

$$\Rightarrow -(a\alpha^2 + 2b\alpha + c)(ac - b^2) = 0$$

$$\Rightarrow a\alpha^2 + 2b\alpha + c = 0 \text{ or } b^2 = ac$$

$\Rightarrow x - \alpha$ is a factor of $a\alpha^2 + 2b\alpha + c$ or a, b, c are in GP.

$$27. \text{ Let } \text{Det}(P) = \begin{vmatrix} a_1 & b_1 & c_1 \\ a_2 & b_2 & c_2 \\ a_3 & b_3 & c_3 \end{vmatrix}$$

$$= a_1(b_2c_3 - b_3c_2) - a_2(b_1c_3 - b_3c_1) + a_3(b_1c_2 - b_2c_1)$$

Now, maximum value of $\text{Det}(P) = 6$

$$\text{If } a_1 = 1, a_2 = -1, a_3 = 1, b_2c_3 = b_1c_3 = b_1c_2 = 1$$

$$\text{and } b_3c_2 = b_3c_1 = b_2c_1 = -1$$

But it is not possible as

$$(b_2c_3)(b_3c_1)(b_1c_2) = -1 \text{ and } (b_1c_3)(b_3c_2)(b_2c_1) = 1$$

i.e., $b_1b_2b_3c_1c_2c_3 = 1$ and -1

Similar contradiction occurs when

$$a_1 = 1, a_2 = 1, a_3 = 1, b_2c_1 = b_3c_1 = b_1c_2 = 1$$

$$\text{and } b_3c_2 = b_1c_3 = b_1c_2 = -1$$

Now, for value to be 5 one of the terms must be zero but that will make 2 terms zero which means answer cannot be 5

$$\text{Now, } \begin{vmatrix} 1 & 1 & 1 \\ -1 & 1 & 1 \\ 1 & -1 & 1 \end{vmatrix} = 4$$

Hence, maximum value is 4.

$$28. \text{ Let } \Delta = \begin{vmatrix} 1 & \log_x y & \log_x z \\ \log_y x & 1 & \log_y z \\ \log_z x & \log_z y & 1 \end{vmatrix}$$

$$= \begin{vmatrix} 1 & \frac{\log y}{\log x} & \frac{\log z}{\log x} \\ \frac{\log x}{\log y} & 1 & \frac{\log z}{\log y} \\ \frac{\log x}{\log z} & \frac{\log y}{\log z} & 1 \end{vmatrix}$$

On dividing and multiplying R_1, R_2, R_3 by $\log x, \log y, \log z$, respectively.

$$= \frac{1}{\log x \log y \log z} \begin{vmatrix} \log x & \log y & \log z \\ \log x & \log y & \log z \\ \log x & \log y & \log z \end{vmatrix} = 0$$

$$29. \begin{vmatrix} 1 & a & a^2 - bc \\ 1 & b & b^2 - ca \\ 1 & c & c^2 - ab \end{vmatrix} = \begin{vmatrix} 1 & a & a^2 \\ 1 & b & b^2 \\ 1 & c & c^2 \end{vmatrix} - \begin{vmatrix} 1 & a & bc \\ 1 & b & ca \\ 1 & c & ab \end{vmatrix}$$

$$\text{Now, } \begin{vmatrix} 1 & a & bc \\ 1 & b & ca \\ 1 & c & ab \end{vmatrix} = \frac{1}{abc} \begin{vmatrix} a & a^2 & abc \\ b & b^2 & abc \\ c & c^2 & abc \end{vmatrix}$$

Applying $R_1 \rightarrow aR_1, R_2 \rightarrow bR_2, R_3 \rightarrow cR_3$

$$= \frac{1}{abc} \cdot abc \begin{vmatrix} a & a^2 & 1 \\ b & b^2 & 1 \\ c & c^2 & 1 \end{vmatrix} = \begin{vmatrix} 1 & a & a^2 \\ 1 & b & b^2 \\ 1 & c & c^2 \end{vmatrix}$$

$$\therefore \begin{vmatrix} 1 & a & a^2 - bc \\ 1 & b & b^2 - ca \\ 1 & c & c^2 - ab \end{vmatrix} = 0$$

$$30. \text{ Given, } \begin{vmatrix} x & 3 & 7 \\ 2 & x & 2 \\ 7 & 6 & x \end{vmatrix} = 0$$

Applying $R_1 \rightarrow R_1 + R_2 + R_3$

$$\Rightarrow \begin{vmatrix} x+9 & x+9 & x+9 \\ 2 & x & 2 \\ 7 & 6 & x \end{vmatrix} = 0 \Rightarrow (x+9) \begin{vmatrix} 1 & 1 & 1 \\ 2 & x & 2 \\ 7 & 6 & x \end{vmatrix} = 0$$

Applying $C_2 \rightarrow C_2 - C_1$ and $C_3 \rightarrow C_3 - C_1$

$$\Rightarrow (x+9) \begin{vmatrix} 1 & 0 & 0 \\ 2 & x-2 & 0 \\ 7 & -1 & x-7 \end{vmatrix} = 0 \Rightarrow (x+9)(x-2)(x-7) = 0$$

$$\Rightarrow x = -9, 2, 7 \text{ are the roots.}$$

\therefore Other two roots are 2 and 7.

$$31. \text{ Given, } \begin{vmatrix} 1 & 4 & 20 \\ 1 & -2 & 5 \\ 1 & 2x & 5x^2 \end{vmatrix} = 0$$

$$\Rightarrow 1(-10x^2 - 10x) - 4(5x^2 - 5) + 20(2x + 2) = 0$$

$$\Rightarrow -30x^2 + 30x + 60 = 0$$

$$\Rightarrow (x-2)(x+1) = 0$$

$$\Rightarrow x = 2, -1$$

Hence, the solution set is $\{-1, 2\}$.

$$32. \text{ Given, } \begin{vmatrix} \lambda^2 + 3\lambda & \lambda - 1 & \lambda + 3 \\ \lambda + 1 & -2\lambda & \lambda - 4 \\ \lambda - 3 & \lambda + 4 & 3\lambda \end{vmatrix}$$

$$= p\lambda^4 + q\lambda^3 + r\lambda^2 + s\lambda + t$$

Thus, the value of t is obtained by putting $\lambda = 0$.

$$\Rightarrow \begin{vmatrix} 0 & -1 & 3 \\ 1 & 0 & -4 \\ -3 & 4 & 0 \end{vmatrix} = t$$

$$\Rightarrow t = 0$$

[\therefore determinants of odd order skew-symmetric matrix is zero]

33. Let $\Delta = \begin{vmatrix} 1 & a & bc \\ 1 & b & ca \\ 1 & c & ab \end{vmatrix} = \frac{1}{abc} \begin{vmatrix} a & a^2 & abc \\ b & b^2 & abc \\ c & c^2 & abc \end{vmatrix}$

Applying $R_1 \rightarrow aR_1, R_2 \rightarrow bR_2, R_3 \rightarrow cR_3$

$$= \frac{1}{abc} \cdot abc \begin{vmatrix} a & a^2 & 1 \\ b & b^2 & 1 \\ c & c^2 & 1 \end{vmatrix} = \begin{vmatrix} 1 & a & a^2 \\ 1 & b & b^2 \\ 1 & c & c^2 \end{vmatrix}$$

$$\therefore \begin{vmatrix} 1 & a & bc \\ 1 & b & ca \\ 1 & c & ab \end{vmatrix} = \begin{vmatrix} 1 & a & a^2 \\ 1 & b & b^2 \\ 1 & c & c^2 \end{vmatrix}$$

Hence, statement is false.

34. Since, $M^T M = I$ and $|M| = 1$

$$\begin{aligned} \therefore |M - I| &= |IM - M^T M| && [\because IM = M] \\ \Rightarrow |M - I| &= |(I - M^T)M| = |(I - M)^T| |M| = |I - M| \\ &= (-1)^3 |M - I| && [\because I - M \text{ is a } 3 \times 3 \text{ matrix}] \\ &= -|M - I| \\ \Rightarrow 2|M - I| &= 0 \\ \Rightarrow |M - I| &= 0 \end{aligned}$$

35. Given, $\begin{vmatrix} ax - by - c & bx + ay & cx + a \\ bx + ay & -ax + by - c & cy + b \\ cx + a & cy + b & -ax - by + c \end{vmatrix} = 0$

$$\Rightarrow \frac{1}{a} \begin{vmatrix} a^2x - aby - ac & bx + ay & cx + a \\ abx + a^2y & -ax + by - c & cy + b \\ acx + a^2 & cy + b & -ax - by + c \end{vmatrix} = 0$$

Applying $C_1 \rightarrow C_1 + bC_2 + cC_3$

$$\Rightarrow \frac{1}{a} \begin{vmatrix} (a^2 + b^2 + c^2)x & ay + bx & cx + a \\ (a^2 + b^2 + c^2)y & by - c - ax & b + cy \\ a^2 + b^2 + c^2 & b + cy & c - ax - by \end{vmatrix} = 0$$

$$\Rightarrow \frac{1}{a} \begin{vmatrix} x & ay + bx & cx + a \\ y & by - c - ax & b + cy \\ 1 & b + cy & c - ax - by \end{vmatrix} = 0$$

[$\because a^2 + b^2 + c^2 = 1$]

Applying $C_2 \rightarrow C_2 - bC_1$ and $C_3 \rightarrow C_3 - cC_1$

$$\Rightarrow \frac{1}{a} \begin{vmatrix} x & ay & a \\ y & -c - ax & b \\ 1 & cy & -ax - by \end{vmatrix} = 0$$

$$\Rightarrow \frac{1}{ax} \begin{vmatrix} x^2 & axy & ax \\ y & -c - ax & b \\ 1 & cy & -ax - by \end{vmatrix} = 0$$

Applying $R_1 \rightarrow R_1 + yR_2 + R_3$

$$\Rightarrow \frac{1}{ax} \begin{vmatrix} x^2 + y^2 + 1 & 0 & 0 \\ y & -c - ax & b \\ 1 & cy & -ax - by \end{vmatrix} = 0$$

$$\Rightarrow \frac{1}{ax} [(x^2 + y^2 + 1) \{-c - ax\}(-ax - by) - b(cy)] = 0$$

$$\Rightarrow \frac{1}{ax} [(x^2 + y^2 + 1)(acx + bcy + a^2x^2 + abxy - bcy)] = 0$$

$$\Rightarrow \frac{1}{ax} [(x^2 + y^2 + 1)(acx + a^2x^2 + abxy)] = 0$$

$$\Rightarrow \frac{1}{ax} [ax(x^2 + y^2 + 1)(c + ax + by)] = 0$$

$$\Rightarrow (x^2 + y^2 + 1)(ax + by + c) = 0$$

$$\Rightarrow ax + by + c = 0$$

which represents a straight line.

36. Let $\Delta = \begin{vmatrix} \sin \theta & \cos \theta & \sin 2\theta \\ \sin \left(\theta + \frac{2\pi}{3}\right) & \cos \left(\theta + \frac{2\pi}{3}\right) & \sin \left(2\theta + \frac{4\pi}{3}\right) \\ \sin \left(\theta - \frac{2\pi}{3}\right) & \cos \left(\theta - \frac{2\pi}{3}\right) & \sin \left(2\theta - \frac{4\pi}{3}\right) \end{vmatrix}$

Applying $R_2 \rightarrow R_2 + R_3$

$$= \begin{vmatrix} \sin \theta & \cos \theta & \sin 2\theta \\ \sin \left(\theta + \frac{2\pi}{3}\right) & \cos \left(\theta + \frac{2\pi}{3}\right) & \sin \left(2\theta + \frac{4\pi}{3}\right) \\ + \sin \left(\theta - \frac{2\pi}{3}\right) & + \cos \left(\theta - \frac{2\pi}{3}\right) & + \sin \left(2\theta - \frac{4\pi}{3}\right) \\ \sin \left(\theta - \frac{2\pi}{3}\right) & \cos \left(\theta - \frac{2\pi}{3}\right) & \sin \left(2\theta - \frac{4\pi}{3}\right) \end{vmatrix}$$

Now, $\sin \left(\theta + \frac{2\pi}{3}\right) + \sin \left(\theta - \frac{2\pi}{3}\right)$

$$= 2 \sin \left(\frac{\theta + \frac{2\pi}{3} + \theta - \frac{2\pi}{3}}{2}\right) \cos \left(\frac{\theta + \frac{2\pi}{3} - \theta + \frac{2\pi}{3}}{2}\right)$$

$$= 2 \sin \theta \cos \frac{2\pi}{3} = 2 \sin \theta \cos \left(\pi - \frac{\pi}{3}\right)$$

$$= -2 \sin \theta \cos \frac{\pi}{3} = -\sin \theta$$

and $\cos \left(\theta + \frac{2\pi}{3}\right) + \cos \left(\theta - \frac{2\pi}{3}\right)$

$$= 2 \cos \left(\frac{\theta + \frac{2\pi}{3} + \theta - \frac{2\pi}{3}}{2}\right) \cos \left(\frac{\theta + \frac{2\pi}{3} - \theta + \frac{2\pi}{3}}{2}\right)$$

$$= 2 \cos \theta \cos \left(\frac{2\pi}{3}\right)$$

$$= 2 \cos \theta \left(-\frac{1}{2}\right) = -\cos \theta$$

and $\sin \left(2\theta + \frac{4\pi}{3}\right) + \sin \left(2\theta - \frac{4\pi}{3}\right)$

$$= 2 \sin \left(\frac{2\theta + \frac{4\pi}{3} + 2\theta - \frac{4\pi}{3}}{2}\right) \cos \left(\frac{2\theta + \frac{4\pi}{3} - 2\theta + \frac{4\pi}{3}}{2}\right)$$

$$= 2 \sin 2\theta \cos \frac{4\pi}{3} = 2 \sin 2\theta \cos \left(\pi + \frac{\pi}{3}\right)$$

$$= -2 \sin 2\theta \cos \frac{\pi}{3} = -\sin 2\theta$$

156 Matrices and Determinants

$$\therefore \Delta = \begin{vmatrix} \sin \theta & \cos \theta & \sin 2\theta \\ -\sin \theta & -\cos \theta & -\sin 2\theta \\ \sin\left(\theta - \frac{2\pi}{3}\right) & \cos\left(\theta - \frac{2\pi}{3}\right) & \sin\left(2\theta - \frac{4\pi}{3}\right) \end{vmatrix} = 0$$

[since, R_1 and R_2 are proportional]

37. Given, $f'(x) = \begin{vmatrix} 2ax & 2ax-1 & 2ax+b+1 \\ b & b+1 & -1 \\ 2(ax+b) & 2ax+2b+1 & 2ax+b \end{vmatrix}$

Applying $R_3 \rightarrow R_3 - R_1 - 2R_2$, we get

$$f'(x) = \begin{vmatrix} 2ax & 2ax-1 & 2ax+b+1 \\ b & b+1 & -1 \\ 0 & 0 & 1 \end{vmatrix} = \begin{vmatrix} 2ax & 2ax-1 \\ b & b+1 \end{vmatrix} = \begin{vmatrix} 2ax & -1 \\ b & 1 \end{vmatrix} \quad [C_2 \rightarrow C_2 - C_1]$$

$$\Rightarrow f'(x) = 2ax + b$$

On integrating, we get $f(x) = ax^2 + bx + c$,

where c is an arbitrary constant.

Since, f has maximum at $x = 5/2$.

$$\Rightarrow f'(5/2) = 0 \Rightarrow 5a + b = 0 \quad \dots(i)$$

Also, $f(0) = 2$

$$\Rightarrow c = 2 \text{ and } f(1) = 1$$

$$\Rightarrow a + b + c = 1 \quad \dots(ii)$$

On solving Eqs. (i) and (ii) for a, b , we get

$$a = \frac{1}{4}, b = -\frac{5}{4}$$

Thus, $f(x) = \frac{1}{4}x^2 - \frac{5}{4}x + 2$

38. Since, a, b, c are p th, q th and r th terms of HP.

$$\Rightarrow \frac{1}{a}, \frac{1}{b}, \frac{1}{c} \text{ are in an AP.}$$

$$\Rightarrow \left. \begin{aligned} \frac{1}{a} &= A + (p-1)D \\ \frac{1}{b} &= A + (q-1)D \\ \frac{1}{c} &= A + (r-1)D \end{aligned} \right\} \dots(i)$$

Let $\Delta = \begin{vmatrix} bc & ca & ab \\ p & q & r \\ 1 & 1 & 1 \end{vmatrix} = abc \begin{vmatrix} \frac{1}{a} & \frac{1}{b} & \frac{1}{c} \\ p & q & r \\ 1 & 1 & 1 \end{vmatrix}$ [from Eq. (i)]

$$= abc \begin{vmatrix} A + (p-1)D & A + (q-1)D & A + (r-1)D \\ p & q & r \\ 1 & 1 & 1 \end{vmatrix}$$

Applying $R_1 \rightarrow R_1 - (A-D)R_3 - DR_2$

$$= abc \begin{vmatrix} 0 & 0 & 0 \\ p & q & r \\ 1 & 1 & 1 \end{vmatrix} = 0 \Rightarrow \begin{vmatrix} bc & ca & ab \\ p & q & r \\ 1 & 1 & 1 \end{vmatrix} = 0$$

39. Given, $a > 0, d > 0$ and let

$$\Delta = \begin{vmatrix} \frac{1}{a} & \frac{1}{a(a+d)} & \frac{1}{(a+d)(a+2d)} \\ \frac{1}{(a+d)} & \frac{1}{(a+d)(a+2d)} & \frac{1}{(a+2d)(a+3d)} \\ \frac{1}{(a+2d)} & \frac{1}{(a+2d)(a+3d)} & \frac{1}{(a+3d)(a+4d)} \end{vmatrix}$$

Taking $\frac{1}{a(a+d)(a+2d)}$ common from R_1 ,

$$\frac{1}{(a+d)(a+2d)(a+3d)} \text{ from } R_2,$$

$$\frac{1}{(a+2d)(a+3d)(a+4d)} \text{ from } R_3$$

$$\Rightarrow \Delta = \frac{1}{a(a+d)^2(a+2d)^3(a+3d)^2(a+4d)}$$

$$\begin{vmatrix} (a+d)(a+2d) & (a+2d) & a \\ (a+2d)(a+3d) & (a+3d) & (a+d) \\ (a+3d)(a+4d) & (a+4d) & (a+2d) \end{vmatrix}$$

$$\Rightarrow \Delta = \frac{1}{a(a+d)^2(a+2d)^3(a+3d)^2(a+4d)} \Delta'$$

where, $\Delta' = \begin{vmatrix} (a+d)(a+2d) & (a+2d) & a \\ (a+2d)(a+3d) & (a+3d) & (a+d) \\ (a+3d)(a+4d) & (a+4d) & (a+2d) \end{vmatrix}$

Applying $R_2 \rightarrow R_2 - R_1, R_3 \rightarrow R_3 - R_2$

$$\Rightarrow \Delta' = \begin{vmatrix} (a+d)(a+2d) & (a+2d) & a \\ (a+2d)(2d) & d & d \\ (a+3d)(2d) & d & d \end{vmatrix}$$

Applying $R_3 \rightarrow R_3 - R_2$

$$\Delta' = \begin{vmatrix} (a+d)(a+2d) & (a+2d) & a \\ (a+2d)2d & d & d \\ 2d^2 & 0 & 0 \end{vmatrix}$$

Expanding along R_3 , we get

$$\Delta' = 2d^2 \begin{vmatrix} a+2d & a \\ d & d \end{vmatrix}$$

$$\Delta' = (2d^2)(d)(a+2d-a) = 4d^4$$

$$\therefore \Delta = \frac{4d^4}{a(a+d)^2(a+2d)^3(a+3d)^2(a+4d)}$$

40. Let $\Delta = \begin{vmatrix} \cos(A-P) & \cos(A-Q) & \cos(A-R) \\ \cos(B-P) & \cos(B-Q) & \cos(B-R) \\ \cos(C-P) & \cos(C-Q) & \cos(C-R) \end{vmatrix}$

$$\Rightarrow \Delta = \begin{vmatrix} \cos A \cos P + \sin A \sin P & \cos(A-Q) & \cos(A-R) \\ \cos B \cos P + \sin B \sin P & \cos(B-Q) & \cos(B-R) \\ \cos C \cos P + \sin C \sin P & \cos(C-Q) & \cos(C-R) \end{vmatrix}$$

$$\begin{vmatrix} \cos(A-R) \\ \cos(B-R) \\ \cos(C-R) \end{vmatrix}$$

$$\Rightarrow \Delta = \begin{vmatrix} \cos A \cos P & \cos(A-Q) & \cos(A-R) \\ \cos B \cos P & \cos(B-Q) & \cos(B-R) \\ \cos C \cos P & \cos(C-Q) & \cos(C-R) \end{vmatrix}$$

$$+ \begin{vmatrix} \sin A \sin P & \cos(A-Q) & \cos(A-R) \\ \sin B \sin P & \cos(B-Q) & \cos(B-R) \\ \sin C \sin P & \cos(C-Q) & \cos(C-R) \end{vmatrix}$$

$$\Rightarrow \Delta = \cos P \begin{vmatrix} \cos A & \cos(A-Q) & \cos(A-R) \\ \cos B & \cos(B-Q) & \cos(B-R) \\ \cos C & \cos(C-Q) & \cos(C-R) \end{vmatrix} \\ + \sin P \begin{vmatrix} \sin A & \cos(A-Q) & \cos(A-R) \\ \sin B & \cos(B-Q) & \cos(B-R) \\ \sin C & \cos(C-Q) & \cos(C-R) \end{vmatrix}$$

Applying $C_2 \rightarrow C_2 - C_1 \cos Q$, $C_3 \rightarrow C_3 - C_1 \cos R$ in first determinant and $C_2 \rightarrow C_2 - C_1 \sin Q$ and in second determinant

$$\Rightarrow \Delta = \cos P \begin{vmatrix} \cos A & \sin A \sin Q & \sin A \sin R \\ \cos B & \sin B \sin Q & \sin B \sin R \\ \cos C & \sin C \sin Q & \sin C \sin R \end{vmatrix} \\ + \sin P \begin{vmatrix} \sin A & \cos A \cos Q & \cos A \cos R \\ \sin B & \cos B \cos Q & \cos B \cos R \\ \sin C & \cos C \cos Q & \cos C \cos R \end{vmatrix}$$

$$\Delta = \cos P \sin Q \sin R \begin{vmatrix} \cos A & \sin A & \sin A \\ \cos B & \sin B & \sin B \\ \cos C & \sin C & \sin C \end{vmatrix} \\ + \sin P \cos Q \cos R \begin{vmatrix} \sin A & \cos A & \cos A \\ \sin B & \cos B & \cos B \\ \sin C & \cos C & \cos C \end{vmatrix}$$

$$\Delta = 0 + 0 = 0$$

41. Given, $D = \begin{vmatrix} n! & (n+1)! & (n+2)! \\ (n+1)! & (n+2)! & (n+3)! \\ (n+2)! & (n+3)! & (n+4)! \end{vmatrix}$

Taking $n!$, $(n+1)!$ and $(n+2)!$ common from R_1 , R_2 and R_3 , respectively.

$$\therefore D = n!(n+1)!(n+2)! \begin{vmatrix} 1 & (n+1) & (n+1)(n+2) \\ 1 & (n+2) & (n+2)(n+3) \\ 1 & (n+3) & (n+3)(n+4) \end{vmatrix}$$

Applying $R_2 \rightarrow R_2 - R_1$ and $R_3 \rightarrow R_3 - R_2$, we get

$$D = n!(n+1)!(n+2)! \begin{vmatrix} 1 & (n+1) & (n+1)(n+2) \\ 0 & 1 & 2n+4 \\ 0 & 1 & 2n+6 \end{vmatrix}$$

Expanding along C_1 , we get

$$D = (n!)(n+1)!(n+2)! [(2n+6) - (2n+4)] \\ D = (n!)(n+1)!(n+2)! [2]$$

On dividing both side by $(n!)^3$

$$\Rightarrow \frac{D}{(n!)^3} = \frac{(n!)(n+1)(n+1)(n+2)2}{(n!)^3}$$

$$\Rightarrow \frac{D}{(n!)^3} = 2(n+1)(n+1)(n+2)$$

$$\Rightarrow \frac{D}{(n!)^3} = 2(n^3 + 4n^2 + 5n + 2) \\ = 2n(n^2 + 4n + 5) + 4$$

$$\Rightarrow \frac{D}{(n!)^3} - 4 = 2n(n^2 + 4n + 5)$$

which shows that $\left[\frac{D}{(n!)^3} - 4 \right]$ is divisible by n .

42. Let $\Delta = \begin{vmatrix} p & b & c \\ a & q & c \\ a & b & r \end{vmatrix}$

Applying $R_1 \rightarrow R_2 - R_1$ and $R_3 \rightarrow R_3 - R_1$, we get

$$\Delta = \begin{vmatrix} p & b & c \\ a-p & q-b & 0 \\ a-p & 0 & r-c \end{vmatrix}$$

$$= c \begin{vmatrix} a-p & q-b \\ a-p & 0 \end{vmatrix} + (r-c) \begin{vmatrix} p & b \\ a-p & q-b \end{vmatrix}$$

$$= -c(a-p)(q-b) + (r-c)[p(q-b) - b(a-p)] \\ = -c(a-p)(q-b) + p(r-c)(q-b) - b(r-c)(a-p)$$

Since, $\Delta = 0$

$$\Rightarrow -c(a-p)(q-b) + p(r-c)(q-b) - b(r-c)(a-p) = 0$$

$$\Rightarrow \frac{c}{r-c} + \frac{p}{p-a} + \frac{b}{q-b} = 0$$

[on dividing both sides by $(a-p)(q-b)(r-c)$]

$$\Rightarrow \frac{p}{p-a} + \frac{b}{q-b} + 1 + \frac{c}{r-c} + 1 = 2$$

$$\Rightarrow \frac{p}{p-a} + \frac{q}{q-b} + \frac{r}{r-c} = 2$$

43. We know, $A28 = A \times 100 + 2 \times 10 + 8$

$$3B9 = 3 \times 100 + B \times 10 + 9$$

and $62C = 6 \times 100 + 2 \times 10 + C$

Since, $A28$, $3B9$ and $62C$ are divisible by k , therefore there exist positive integers m_1 , m_2 and m_3 such that,

$$100 \times A + 10 \times 2 + 8 = m_1 k, 100 \times 3 + 10 \times B + 9 = m_2 k \\ \text{and } 100 \times 6 + 10 \times 2 + C = m_3 k \quad \dots (i)$$

$$\therefore \Delta = \begin{vmatrix} A & 3 & 6 \\ 8 & 9 & C \\ 2 & B & 2 \end{vmatrix}$$

Applying $R_2 \rightarrow 100R_1 + 10R_3 + R_2$

$$\Rightarrow \Delta = \begin{vmatrix} A & 3 & 6 \\ 100A+2 \times 10+8 & 100 \times 3+10 \times B+9 & 3 \\ 2 & B & 2 \end{vmatrix} \\ \begin{vmatrix} A & 3 & 6 \\ 100 \times 6+10 \times 2+C & 6 & 2 \end{vmatrix}$$

$$= \begin{vmatrix} A & 3 & 6 \\ A28 & 3B9 & 62C \\ 2 & B & 2 \end{vmatrix} \quad [\text{from Eq. (i)}]$$

$$= \begin{vmatrix} A & 3 & 6 \\ m_1 k & m_2 k & m_3 k \\ 2 & B & 2 \end{vmatrix} = k \begin{vmatrix} A & 3 & 6 \\ m_1 & m_2 & m_3 \\ 2 & B & 2 \end{vmatrix}$$

$$\therefore \Delta = mk$$

Hence, determinant is divisible by k .

158 Matrices and Determinants

44. Given, $\Delta_a = \begin{vmatrix} a-1 & n & 6 \\ (a-1)^2 & 2n^2 & 4n-2 \\ (a-1)^3 & 3n^3 & 3n^2-3n \end{vmatrix}$

$$\therefore \sum_{a=1}^n \Delta_a = \begin{vmatrix} \sum_{a=1}^n (a-1) & n & 6 \\ \sum_{a=1}^n (a-1)^2 & 2n^2 & 4n-2 \\ \sum_{a=1}^n (a-1)^3 & 3n^3 & 3n^2-3n \end{vmatrix}$$

$$= \begin{vmatrix} \frac{n(n-1)}{2} & n & 6 \\ \frac{n(n-1)(2n-1)}{6} & 2n^2 & 4n-2 \\ \frac{n^2(n-1)^2}{4} & 3n^3 & 3n^2-3n \end{vmatrix}$$

$$= \frac{n^2(n-1)}{2} \begin{vmatrix} 1 & 1 & 6 \\ \frac{2n-1}{3} & 2n & 4n-2 \\ \frac{n(n-1)}{2} & 3n^2 & 3n^2-3n \end{vmatrix}$$

$$= \frac{n^3(n-1)}{12} \begin{vmatrix} 1 & 1 & 6 \\ 2n-1 & 6n & 12n-6 \\ n-1 & 6n & 6n-6 \end{vmatrix}$$

Applying $C_3 \rightarrow C_3 - 6C_1$

$$= \frac{n^3(n-1)}{12} \begin{vmatrix} 1 & 1 & 0 \\ 2n-1 & 6n & 0 \\ n-1 & 6n & 0 \end{vmatrix} = 0$$

$$\Rightarrow \sum_{a=1}^n \Delta_a = c \quad [c=0, \text{i.e. constant}]$$

45. Let $\Delta = \begin{vmatrix} xC_r & xC_{r+1} & xC_{r+2} \\ yC_r & yC_{r+1} & yC_{r+2} \\ zC_r & zC_{r+1} & zC_{r+2} \end{vmatrix}$

Applying $C_3 \rightarrow C_3 + C_2$

$$\Delta = \begin{vmatrix} xC_r & xC_{r+1} & x^{+1}C_{r+2} \\ yC_r & yC_{r+1} & y^{+1}C_{r+2} \\ zC_r & zC_{r+1} & z^{+1}C_{r+2} \end{vmatrix}$$

[$\therefore {}^nC_r + {}^nC_{r-1} = {}^{n+1}C_r$]

Applying $C_2 \rightarrow C_2 + C_1$

$$\Delta = \begin{vmatrix} xC_r & x^{+1}C_{r+1} & x^{+1}C_{r+2} \\ yC_r & y^{+1}C_{r+1} & y^{+1}C_{r+2} \\ zC_r & z^{+1}C_{r+1} & z^{+1}C_{r+2} \end{vmatrix}$$

Applying $C_3 \rightarrow C_3 + C_2$

$$\Rightarrow \Delta = \begin{vmatrix} xC_r & x^{+1}C_{r+1} & x^{+2}C_{r+2} \\ yC_r & y^{+1}C_{r+1} & y^{+2}C_{r+2} \\ zC_r & z^{+1}C_{r+1} & z^{+2}C_{r+2} \end{vmatrix} \quad \text{Hence proved.}$$

46. Since, α is repeated root of $f(x) = 0$.

$$\therefore f(x) = a(x - \alpha)^2, a \in \text{constant} (\neq 0)$$

$$\text{Let } \phi(x) = \begin{vmatrix} A(x) & B(x) & C(x) \\ A(\alpha) & B(\alpha) & C(\alpha) \\ A'(\alpha) & B'(\alpha) & C'(\alpha) \end{vmatrix}$$

To show $\phi(x)$ is divisible by $(x - \alpha)^2$, it is sufficient to show that $\phi(\alpha) = 0$ and $\phi'(\alpha) = 0$.

$$\therefore \phi(\alpha) = \begin{vmatrix} A(\alpha) & B(\alpha) & C(\alpha) \\ A(\alpha) & B(\alpha) & C(\alpha) \\ A'(\alpha) & B'(\alpha) & C'(\alpha) \end{vmatrix} = 0 \quad [\because R_1 \text{ and } R_2 \text{ are identical}]$$

$$\text{Again, } \phi'(x) = \begin{vmatrix} A'(x) & B'(x) & C'(x) \\ A(\alpha) & B(\alpha) & C(\alpha) \\ A'(\alpha) & B'(\alpha) & C'(\alpha) \end{vmatrix}$$

$$\phi'(\alpha) = \begin{vmatrix} A'(\alpha) & B'(\alpha) & C'(\alpha) \\ A(\alpha) & B(\alpha) & C(\alpha) \\ A'(\alpha) & B'(\alpha) & C'(\alpha) \end{vmatrix} = 0 \quad [\because R_1 \text{ and } R_3 \text{ are identical}]$$

Thus, α is a repeated root of $\phi(x) = 0$.

Hence, $\phi(x)$ is divisible by $f(x)$.

47. Let $\Delta = \begin{vmatrix} x^2 + x & x + 1 & x - 2 \\ 2x^2 + 3x - 1 & 3x & 3x - 3 \\ x^2 + 2x + 3 & 2x - 1 & 2x - 1 \end{vmatrix}$

Applying $R_2 \rightarrow R_2 - (R_1 + R_3)$, we get

$$\Delta = \begin{vmatrix} x^2 + x & x + 1 & x - 2 \\ -4 & 0 & 0 \\ x^2 + 2x + 3 & 2x - 1 & 2x - 1 \end{vmatrix}$$

Applying $R_1 \rightarrow R_1 + \frac{x^2}{4}R_2$

and $R_3 \rightarrow R_3 + \frac{x^2}{4}R_2$, we get

$$\Delta = \begin{vmatrix} x & x + 1 & x - 2 \\ -4 & 0 & 0 \\ 2x + 3 & 2x - 1 & 2x - 1 \end{vmatrix}$$

$$\text{Applying } R_3 \rightarrow R_3 - 2R_1 = \begin{vmatrix} x + 0 & x + 1 & x - 2 \\ -4 & 0 & 0 \\ 3 & -3 & 3 \end{vmatrix}$$

$$= \begin{vmatrix} x & x & x \\ -4 & 0 & 0 \\ 3 & -3 & 3 \end{vmatrix} + \begin{vmatrix} 0 & 1 & -2 \\ -4 & 0 & 0 \\ 3 & -3 & 3 \end{vmatrix}$$

$$= x \begin{vmatrix} 1 & 1 & 1 \\ -4 & 0 & 0 \\ 3 & -3 & 3 \end{vmatrix} + \begin{vmatrix} 0 & 1 & -2 \\ -4 & 0 & 0 \\ 3 & -3 & 3 \end{vmatrix}$$

$$\Rightarrow \Delta = Ax + B$$

$$\text{where, } A = \begin{vmatrix} 1 & 1 & 1 \\ -4 & 0 & 0 \\ 3 & -3 & 3 \end{vmatrix}$$

$$\text{and } B = \begin{vmatrix} 0 & 1 & -2 \\ -4 & 0 & 0 \\ 3 & -3 & 3 \end{vmatrix}$$

48. Let $\Delta = \begin{vmatrix} a & b & c \\ b & c & a \\ c & a & b \end{vmatrix}$

Applying $C_1 \rightarrow C_1 + C_2 + C_3$

$$\Delta = \begin{vmatrix} a+b+c & b & c \\ a+b+c & c & a \\ a+b+c & a & b \end{vmatrix} = (a+b+c) \begin{vmatrix} 1 & b & c \\ 1 & c & a \\ 1 & a & b \end{vmatrix}$$

Applying $R_2 \rightarrow R_2 - R_1$ and $R_3 \rightarrow R_3 - R_1$, we get

$$\begin{aligned} &= (a+b+c) \begin{vmatrix} 1 & b & c \\ 0 & c-b & a-c \\ 0 & a-b & b-c \end{vmatrix} \\ &= (a+b+c) [-(c-b)^2 - (a-b)(a-c)] \\ &= -(a+b+c)(a^2 + b^2 + c^2 - ab - bc - ca) \\ &= -\frac{1}{2}(a+b+c)(2a^2 + 2b^2 + 2c^2 - 2ab - 2bc - 2ca) \\ &= -\frac{1}{2}(a+b+c)[(a-b)^2 + (b-c)^2 + (c-a)^2] \end{aligned}$$

which is always negative.

Topic 3 Adjoint and Inverse of a Matrix

1. It is given that matrix.

$$M = \begin{bmatrix} \sin^4 \theta & -1 - \sin^2 \theta \\ 1 + \cos^2 \theta & \cos^4 \theta \end{bmatrix} = \alpha I + \beta M^{-1}, \text{ where}$$

$\alpha = \alpha(\theta)$ and $\beta = \beta(\theta)$ are real numbers and I is the 2×2 identity matrix.

$$\begin{aligned} \text{Now, } \det(M) = |M| &= \sin^4 \theta \cos^4 \theta + 1 + \sin^2 \theta + \cos^2 \theta \\ &\quad + \sin^2 \theta \cos^2 \theta \\ &= \sin^4 \theta \cos^4 \theta + \sin^2 \theta \cos^2 \theta + 2 \end{aligned}$$

$$\text{and } \begin{bmatrix} \sin^4 \theta & -1 - \sin^2 \theta \\ 1 + \cos^2 \theta & \cos^4 \theta \end{bmatrix} = \begin{bmatrix} \alpha & 0 \\ 0 & \alpha \end{bmatrix} + \frac{\beta}{|M|} (\text{adj } M)$$

$$\left[\because M^{-1} = \frac{\text{adj } M}{|M|} \right]$$

$$\Rightarrow \begin{bmatrix} \sin^4 \theta & -1 - \sin^2 \theta \\ 1 + \cos^2 \theta & \cos^4 \theta \end{bmatrix} = \begin{bmatrix} \alpha & 0 \\ 0 & \alpha \end{bmatrix}$$

$$+ \frac{\beta}{|M|} \begin{bmatrix} \cos^4 \theta & 1 + \sin^2 \theta \\ -1 - \cos^2 \theta & \sin^4 \theta \end{bmatrix} \left[\because \text{adj } \begin{bmatrix} a & b \\ c & d \end{bmatrix} = \begin{bmatrix} d & -b \\ -c & a \end{bmatrix} \right]$$

$$\Rightarrow \beta = -|M| \text{ and } \alpha = \sin^4 \theta + \cos^4 \theta$$

$$\Rightarrow \alpha = \alpha(\theta) = 1 - \frac{1}{2} \sin^2(2\theta), \text{ and}$$

$$\begin{aligned} \beta = \beta(\theta) &= -\left\{ \left(\sin^2 \theta \cos^2 \theta + \frac{1}{2} \right)^2 + \frac{7}{4} \right\} \\ &= -\left\{ \left(\frac{\sin^2(2\theta)}{4} + \frac{1}{2} \right)^2 + \frac{7}{4} \right\} \end{aligned}$$

$$\text{Now, } \alpha^* = \alpha_{\min} = \frac{1}{2} \text{ and } \beta^* = \beta_{\min} = -\frac{37}{16}$$

$\therefore \alpha$ is minimum at $\sin^2(2\theta) = 1$ and β is minimum at $\sin^2(2\theta) = 1$

$$\text{So, } \alpha^* + \beta^* = \frac{1}{2} - \frac{37}{16} = -\frac{29}{16}$$

2. Given matrix B is the inverse matrix of 3×3 matrix A ,

$$\text{where } B = \begin{bmatrix} 5 & 2\alpha & 1 \\ 0 & 2 & 1 \\ \alpha & 3 & -1 \end{bmatrix}$$

We know that,

$$\det(A) = \frac{1}{\det(B)} \quad \left[\because \det(A^{-1}) = \frac{1}{\det(A)} \right]$$

$$\text{Since, } \det(A) + 1 = 0 \quad (\text{given})$$

$$\frac{1}{\det(B)} + 1 = 0$$

$$\Rightarrow \det(B) = -1$$

$$\Rightarrow 5(-2-3) - 2\alpha(0-\alpha) + 1(0-2\alpha) = -1$$

$$\Rightarrow -25 + 2\alpha^2 - 2\alpha = -1$$

$$\Rightarrow 2\alpha^2 - 2\alpha - 24 = 0$$

$$\Rightarrow \alpha^2 - \alpha - 12 = 0$$

$$\Rightarrow (\alpha - 4)(\alpha + 3) = 0$$

$$\Rightarrow \alpha = -3, 4$$

So, required sum of all values of α is $4 - 3 = 1$

3. $|A| = \begin{vmatrix} e^t & e^{-t} \cos t & e^{-t} \sin t \\ e^t & -e^{-t} \cos t - e^{-t} \sin t & -e^{-t} \sin t + e^{-t} \cos t \\ e^t & 2e^{-t} \sin t & -2e^{-t} \cos t \end{vmatrix}$

$$= (e^t)(e^{-t})(e^{-t}) \begin{vmatrix} 1 & \cos t & \sin t \\ 1 - \cos t - \sin t & -\sin t + \cos t \\ 1 & 2 \sin t & -2 \cos t \end{vmatrix}$$

(taking common from each column)

Applying $R_2 \rightarrow R_2 - R_1$ and $R_3 \rightarrow R_3 - R_1$, we get

$$[\because e^{t-t} = e^0 = 1]$$

$$= e^{-t} \begin{vmatrix} 1 & \cos t & \sin t \\ 0 & -2 \cos t - \sin t & -2 \sin t + \cos t \\ 0 & 2 \sin t - \cos t & -2 \cos t - \sin t \end{vmatrix}$$

$$= e^{-t} ((2 \cos t + \sin t)^2 + (2 \sin t - \cos t)^2)$$

(expanding along column 1)

$$= e^{-t} (5 \cos^2 t + 5 \sin^2 t)$$

$$= 5e^{-t} \quad (\because \cos^2 t + \sin^2 t = 1)$$

$$\Rightarrow |A| = 5e^{-t} \neq 0$$

$\therefore A$ is invertible for all $t \in R$

[\because If $|A| \neq 0$, then A is invertible]

4. Given, $|ABA^T| = 8$

$$\Rightarrow |A||B||A^T| = 8 \quad [\because |XY| = |X||Y|]$$

$$\therefore |A|^2|B| = 8 \quad \dots(i) [\because |A^T| = |A|]$$

Also, we have $|AB^{-1}| = 8$

$$\Rightarrow |A||B^{-1}| = 8$$

$$\Rightarrow \frac{|A|}{|B|} = 8 \quad \dots(ii) \left[\because |A^{-1}| = |A|^{-1} = \frac{1}{|A|} \right]$$

On multiplying Eqs. (i) and (ii), we get

$$|A|^3 = 8 \cdot 8 = 4^3$$

$$\Rightarrow |A| = 4$$

160 Matrices and Determinants

$$\Rightarrow |B| = \frac{|A|}{8} = \frac{4}{8} = \frac{1}{2}$$

$$\begin{aligned} \text{Now, } |BA^{-1}B^T| &= |B| \frac{1}{|A|} |B| \\ &= \left(\frac{1}{2}\right) \frac{1}{4} \left(\frac{1}{2}\right) = \frac{1}{16} \end{aligned}$$

5. We have, $A = \begin{bmatrix} \cos \theta & -\sin \theta \\ \sin \theta & \cos \theta \end{bmatrix}$

$$\therefore |A| = \cos^2 \theta + \sin^2 \theta = 1$$

$$\text{and } \text{adj } A = \begin{bmatrix} \cos \theta & \sin \theta \\ -\sin \theta & \cos \theta \end{bmatrix}$$

$$[\because \text{ If } A = \begin{bmatrix} a & b \\ c & d \end{bmatrix}, \text{ then } \text{adj } A = \begin{bmatrix} d & -b \\ -c & a \end{bmatrix}]$$

$$\Rightarrow A^{-1} = \begin{bmatrix} \cos \theta & \sin \theta \\ -\sin \theta & \cos \theta \end{bmatrix} \quad \left(\because A^{-1} = \frac{\text{adj } A}{|A|} \right)$$

$$\text{Note that, } A^{-50} = (A^{-1})^{50}$$

$$\text{Now, } A^{-2} = (A^{-1})(A^{-1})$$

$$\begin{aligned} \Rightarrow A^{-2} &= \begin{bmatrix} \cos \theta & \sin \theta \\ -\sin \theta & \cos \theta \end{bmatrix} \begin{bmatrix} \cos \theta & \sin \theta \\ -\sin \theta & \cos \theta \end{bmatrix} \\ &= \begin{bmatrix} \cos^2 \theta - \sin^2 \theta & \cos \theta \sin \theta + \sin \theta \cos \theta \\ -\cos \theta \sin \theta - \cos \theta \sin \theta & -\sin^2 \theta + \cos^2 \theta \end{bmatrix} \\ &= \begin{bmatrix} \cos 2\theta & \sin 2\theta \\ -\sin 2\theta & \cos 2\theta \end{bmatrix} \end{aligned}$$

$$\text{Also, } A^{-3} = (A^{-2})(A^{-1})$$

$$\begin{aligned} A^{-3} &= \begin{bmatrix} \cos 2\theta & \sin 2\theta \\ -\sin 2\theta & \cos 2\theta \end{bmatrix} \begin{bmatrix} \cos \theta & \sin \theta \\ -\sin \theta & \cos \theta \end{bmatrix} \\ &= \begin{bmatrix} \cos 3\theta & \sin 3\theta \\ -\sin 3\theta & \cos 3\theta \end{bmatrix} \end{aligned}$$

$$\text{Similarly, } A^{-50} = \begin{bmatrix} \cos 50\theta & \sin 50\theta \\ -\sin 50\theta & \cos 50\theta \end{bmatrix}$$

$$= \begin{bmatrix} \cos \frac{25}{6}\pi & \sin \frac{25}{6}\pi \\ -\sin \frac{25}{6}\pi & \cos \frac{25}{6}\pi \end{bmatrix} \quad \left(\text{when } \theta = \frac{\pi}{12} \right)$$

$$= \begin{bmatrix} \cos \frac{\pi}{6} & \sin \frac{\pi}{6} \\ -\sin \frac{\pi}{6} & \cos \frac{\pi}{6} \end{bmatrix} \left[\begin{array}{l} \because \cos \left(\frac{25\pi}{6} \right) = \cos \left(4\pi + \frac{\pi}{6} \right) = \cos \frac{\pi}{6} \\ \text{and } \sin \left(\frac{25\pi}{6} \right) = \sin \left(4\pi + \frac{\pi}{6} \right) = \sin \frac{\pi}{6} \end{array} \right]$$

$$= \begin{bmatrix} \frac{\sqrt{3}}{2} & \frac{1}{2} \\ -\frac{1}{2} & \frac{\sqrt{3}}{2} \end{bmatrix}$$

6. We have, $A = \begin{bmatrix} 2 & -3 \\ -4 & 1 \end{bmatrix}$

$$\begin{aligned} \therefore A^2 &= A \cdot A = \begin{bmatrix} 2 & -3 \\ -4 & 1 \end{bmatrix} \begin{bmatrix} 2 & -3 \\ -4 & 1 \end{bmatrix} \\ &= \begin{bmatrix} 4+12 & -6-3 \\ -8-4 & 12+1 \end{bmatrix} = \begin{bmatrix} 16 & -9 \\ -12 & 13 \end{bmatrix} \end{aligned}$$

$$\begin{aligned} \text{Now, } 3A^2 + 12A &= 3 \begin{bmatrix} 16 & -9 \\ -12 & 13 \end{bmatrix} + 12 \begin{bmatrix} 2 & -3 \\ -4 & 1 \end{bmatrix} \\ &= \begin{bmatrix} 48 & -27 \\ -36 & 39 \end{bmatrix} + \begin{bmatrix} 24 & -36 \\ -48 & 12 \end{bmatrix} \\ &= \begin{bmatrix} 72 & -63 \\ -84 & 51 \end{bmatrix} \end{aligned}$$

$$\therefore \text{adj } (3A^2 + 12A) = \begin{bmatrix} 51 & 63 \\ 84 & 72 \end{bmatrix}$$

7. Given, $A = \begin{bmatrix} 5a & -b \\ 3 & 2 \end{bmatrix}$ and $A \text{ adj } A = AA^T$

$$\text{Clearly, } A(\text{adj } A) = |A| I_2$$

[\because if A is square matrix of order n , then $A(\text{adj } A) = (\text{adj } A) \cdot A = |A| I_n$]

$$= \begin{vmatrix} 5a & -b \\ 3 & 2 \end{vmatrix} I_2$$

$$= (10a + 3b) I_2$$

$$= (10a + 3b) \begin{bmatrix} 1 & 0 \\ 0 & 1 \end{bmatrix}$$

$$= \begin{bmatrix} 10a + 3b & 0 \\ 0 & 10a + 3b \end{bmatrix} \quad \dots(i)$$

$$\text{and } AA^T = \begin{bmatrix} 5a & -b \\ 3 & 2 \end{bmatrix} \begin{bmatrix} 5a & 3 \\ -b & 2 \end{bmatrix}$$

$$= \begin{bmatrix} 25a^2 + b^2 & 15a - 2b \\ 15a - 2b & 13 \end{bmatrix} \quad \dots(ii)$$

$$\therefore A(\text{adj } A) = AA^T$$

$$\therefore \begin{bmatrix} 10a + 3b & 0 \\ 0 & 10a + 3b \end{bmatrix} = \begin{bmatrix} 25a^2 + b^2 & 15a - 2b \\ 15a - 2b & 13 \end{bmatrix}$$

[using Eqs. (i) and (ii)]

$$\Rightarrow 15a - 2b = 0$$

$$\Rightarrow a = \frac{2b}{15} \quad \dots(iii)$$

$$\text{and } 10a + 3b = 13 \quad \dots(iv)$$

On substituting the value of 'a' from Eq. (iii) in Eq. (iv), we get

$$10 \cdot \left(\frac{2b}{15} \right) + 3b = 13$$

$$\Rightarrow \frac{20b + 45b}{15} = 13$$

$$\Rightarrow \frac{65b}{15} = 13 \Rightarrow b = 3$$

Now, substituting the value of b in Eq. (iii), we get

$$5a = 2$$

$$\text{Hence, } 5a + b = 2 + 3 = 5$$

8. **PLAN** Use the following properties of transpose $(AB)^T = B^T A^T$, $(A^T)^T = A$ and $A^{-1}A = I$ and simplify. If A is non-singular matrix, then $|A| \neq 0$.

$$\text{Given, } AA^T = A^T A \text{ and } B = A^{-1}A^T$$

$$BB^T = (A^{-1}A^T)(A^{-1}A^T)^T$$

$$= A^{-1}A^T A (A^{-1})^T \quad [\because (AB)^T = B^T A^T]$$

$$\begin{aligned} &= A^{-1}AA^T(A^{-1})^T && [\because AA^T = A^T A] \\ &= IA^T(A^{-1})^T && [\because A^{-1}A = I] \\ &= A^T(A^{-1})^T = (A^{-1}A)^T && [\because (AB)^T = B^T A^T] \\ &= I^T = I \end{aligned}$$

9. Given, $P = \begin{bmatrix} 1 & \alpha & 3 \\ 1 & 3 & 3 \\ 2 & 4 & 4 \end{bmatrix}$

$$\begin{aligned} \therefore |P| &= 1(12 - 12) - \alpha(4 - 6) + 3(4 - 6) = 2\alpha - 6 \\ \therefore P &= \text{adj}(A) && \text{[given]} \\ \therefore |P| &= |\text{adj } A| = |A|^2 = 16 && [\because |\text{adj } A| = |A|^{n-1}] \\ \therefore 2\alpha - 6 &= 16 \\ \Rightarrow 2\alpha &= 22 \\ \Rightarrow \alpha &= 11 \end{aligned}$$

10. Given, $P^T = 2P + I$... (i)

$$\begin{aligned} \therefore (P^T)^T &= (2P + I)^T = 2P^T + I \\ \Rightarrow P &= 2P^T + I \\ \Rightarrow P &= 2(2P + I) + I \\ \Rightarrow P &= 4P + 3I \text{ or } 3P = -3I \\ \Rightarrow PX &= -IX = -X \end{aligned}$$

11. $|A| \neq 0$, as non-singular $\begin{vmatrix} 1 & a & b \\ \omega & 1 & c \\ \omega^2 & \omega & 1 \end{vmatrix} \neq 0$

$$\begin{aligned} \Rightarrow 1(1 - c\omega) - a(\omega - c\omega^2) + b(\omega^2 - \omega^2) &\neq 0 \\ \Rightarrow 1 - c\omega - a\omega + ac\omega^2 &\neq 0 \\ \Rightarrow (1 - c\omega)(1 - a\omega) &\neq 0 \\ \Rightarrow a \neq \frac{1}{\omega}, c \neq \frac{1}{\omega} \end{aligned}$$

$\Rightarrow a = \omega, c = \omega$ and $b \in \{\omega, \omega^2\} \Rightarrow 2$ solutions

12. Given, $M^T = -M, N^T = -N$ and $MN = NM$... (i)

$$\begin{aligned} \therefore M^2 N^2 (M^T N)^{-1} (MN^{-1})^T & \\ \Rightarrow M^2 N^2 N^{-1} (M^T)^{-1} (N^{-1})^T \cdot M^T & \\ \Rightarrow M^2 N (NN^{-1}) (-M)^{-1} (N^T)^{-1} (-M) & \\ \Rightarrow M^2 N I (-M^{-1}) (-N^{-1}) (-M) & \\ \Rightarrow -M^2 N M^{-1} N^{-1} M & \\ \Rightarrow -M \cdot (MN) M^{-1} N^{-1} M = -M(NM) M^{-1} N^{-1} M & \\ \Rightarrow -MN(NM^{-1}) N^{-1} M = -M(NN^{-1}) M \Rightarrow -M^2 & \end{aligned}$$

NOTE Here, non-singular word should not be used, since there is no non-singular 3×3 skew-symmetric matrix.

13. Every square matrix satisfied its characteristic equation,

$$\begin{aligned} \text{i.e. } |A - \lambda I| = 0 &\Rightarrow \begin{vmatrix} 1 - \lambda & 0 & 0 \\ 0 & 1 - \lambda & 1 \\ 0 & -2 & 4 - \lambda \end{vmatrix} = 0 \\ \Rightarrow (1 - \lambda) \{ (1 - \lambda)(4 - \lambda) + 2 \} &= 0 \\ \Rightarrow \lambda^3 - 6\lambda^2 + 11\lambda - 6 &= 0 \\ \Rightarrow A^3 - 6A^2 + 11A - 6I &= O \quad \dots(i) \end{aligned}$$

Given, $6A^{-1} = A^2 + cA + dI$, multiplying both sides by A , we get

$$\begin{aligned} 6I &= A^3 + cA^2 + dA \\ \Rightarrow A^3 + cA^2 + dA - 6I &= O \quad \dots(ii) \end{aligned}$$

On comparing Eqs. (i) and (ii), we get

$$c = -6 \text{ and } d = 11$$

14. It is given that matrix M be a 3×3 invertible matrix, such that

$$\begin{aligned} M^{-1} &= \text{adj}(\text{adj } M) \\ \Rightarrow M^{-1} &= |M| M \\ (\because \text{for a matrix } A \text{ of order 'n' } \text{adj}(\text{adj } A) &= |A|^{n-2} A) \\ \Rightarrow M^{-1} M &= |M| M^2 \Rightarrow M^2 |M| = I \quad \dots(i) \end{aligned}$$

$$\begin{aligned} \therefore \det(M^2 |M|) &= \det(I) = 1 \\ \Rightarrow |M|^3 |M|^2 &= 1 \\ \Rightarrow |M| &= 1 \quad \dots(ii) \end{aligned}$$

from Eqs. (i) and (ii), we get

$$\begin{aligned} M^2 &= I \\ \text{As, adj } M &= |M| M^{-1} = M \\ \Rightarrow (\text{adj } M)^2 &= M^2 \\ \Rightarrow (\text{adj } M)^2 &= I \end{aligned}$$

15. Given square matrix $M = \begin{bmatrix} 0 & 1 & a \\ 1 & 2 & 3 \\ 3 & b & 1 \end{bmatrix}$

and $\text{adj}(M) = \begin{bmatrix} -1 & 1 & -1 \\ 8 & -6 & 2 \\ -5 & 3 & -1 \end{bmatrix}$

$$\therefore |\text{adj}(M)| = |M|^2 = \begin{vmatrix} -1 & 1 & -1 \\ 8 & -6 & 2 \\ -5 & 3 & -1 \end{vmatrix}$$

$$\begin{aligned} \Rightarrow |M|^2 &= -1(6 - 6) - 1(-8 + 10) - 1(24 - 30) = -2 + 6 = 4 \\ \Rightarrow |M| &= \pm 2 \end{aligned}$$

$$\therefore \det(\text{adj } M^2) = |M^2|^2 = |M|^4 = 16$$

As we know $A(\text{adj } A) = |A| I$

$$\Rightarrow M = |M| (\text{adj } M)^{-1} \quad \dots(i)$$

$$\begin{aligned} \therefore (\text{adj } M)^{-1} &= \frac{1}{|\text{adj } M|} \begin{bmatrix} 0 & -2 & -6 \\ -2 & -4 & -2 \\ -4 & -6 & -2 \end{bmatrix}^T \\ &= \frac{1}{4} \begin{bmatrix} 0 & -2 & -4 \\ -2 & -4 & -6 \\ -6 & -2 & -2 \end{bmatrix} \end{aligned}$$

So $\begin{bmatrix} 0 & 1 & a \\ 1 & 2 & 3 \\ 3 & b & 1 \end{bmatrix} = \frac{|M|}{4} \begin{bmatrix} 0 & -2 & -4 \\ -2 & -4 & -6 \\ -6 & -2 & -2 \end{bmatrix}$

$$\Rightarrow |M| = -2, a = 2 \text{ and } b = 1$$

$$\Rightarrow M = \begin{bmatrix} 0 & 1 & 2 \\ 1 & 2 & 3 \\ 3 & 1 & 1 \end{bmatrix}$$

162 Matrices and Determinants

$$\text{Now, If } M \begin{bmatrix} \alpha \\ \beta \\ \gamma \end{bmatrix} = \begin{bmatrix} 1 \\ 2 \\ 3 \end{bmatrix} \Rightarrow \begin{bmatrix} 0 & 1 & 2 \\ 1 & 2 & 3 \\ 3 & 1 & 1 \end{bmatrix} \begin{bmatrix} \alpha \\ \beta \\ \gamma \end{bmatrix} = \begin{bmatrix} 1 \\ 2 \\ 3 \end{bmatrix}$$

$$\Rightarrow B + 2\gamma = 1, \alpha + 2\beta + 3\gamma = 2 \text{ and } 3\alpha + \beta + \gamma = 3$$

$$\Rightarrow \alpha = 1, \beta = -1 \text{ and } \gamma = 1$$

$$\Rightarrow \alpha - \beta + \gamma = 3$$

$$\text{And } (\text{adj } M)^{-1} + \text{adj } (M^{-1})$$

$$= 2(\text{adj } M)^{-1} \quad [\because \text{adj } (M^{-1}) = (\text{adj } M)^{-1}]$$

$$= 2\left(-\frac{M}{2}\right) = -M \quad [\because (\text{adj } M)^{-1} = \frac{M}{|M|} \text{ from Eq. (i)}]$$

$$\text{and } \because a = 2 \text{ and } b = 1, \text{ so } a + b = 3$$

Hence, options (b), (c) and (d) are correct.

$$16. \text{ Here, } P = \begin{bmatrix} 3 & -1 & -2 \\ 2 & 0 & \alpha \\ 3 & -5 & 0 \end{bmatrix}$$

$$\text{Now, } |P| = 3(5\alpha) + 1(-3\alpha) - 2(-10) = 12\alpha + 20 \quad \dots(i)$$

$$\therefore \text{adj } (P) = \begin{bmatrix} 5\alpha & 2\alpha & -10 \\ -10 & 6 & 12 \\ -\alpha & -(3\alpha + 4) & 2 \end{bmatrix}^T$$

$$= \begin{bmatrix} 5\alpha & -10 & -\alpha \\ 2\alpha & 6 & -3\alpha - 4 \\ -10 & 12 & 2 \end{bmatrix} \quad \dots(ii)$$

$$\text{As, } PQ = kI \Rightarrow |P||Q| = |kI|$$

$$\Rightarrow |P||Q| = k^3$$

$$\Rightarrow |P|\left(\frac{k^2}{2}\right) = k^3 \quad \left[\text{given, } |Q| = \frac{k^2}{2} \right]$$

$$\Rightarrow |P| = 2k \quad \dots(iii)$$

$$\therefore PQ = kI \Rightarrow Q = kp^{-1}I$$

$$= k \cdot \frac{\text{adj } P}{|P|} = \frac{k(\text{adj } P)}{2k} \quad [\text{from Eq. (iii)}]$$

$$= \frac{\text{adj } P}{2} = \frac{1}{2} \begin{bmatrix} 5\alpha & -10 & -\alpha \\ 2\alpha & 6 & -3\alpha - 4 \\ -10 & 12 & 2 \end{bmatrix}$$

$$\therefore q_{23} = \frac{-3\alpha - 4}{2} \quad \left[\text{given, } q_{23} = -\frac{k}{8} \right]$$

$$\Rightarrow -\frac{(3\alpha + 4)}{2} = -\frac{k}{8}$$

$$\Rightarrow (3\alpha + 4) \times 4 = k$$

$$\Rightarrow 12\alpha + 16 = k \quad \dots(iv)$$

$$\text{From Eq. (iii), } |P| = 2k$$

$$\Rightarrow 12\alpha + 20 = 2k \quad [\text{from Eq. (i)}] \dots(v)$$

On solving Eqs. (iv) and (v), we get

$$\alpha = -1 \text{ and } k = 4 \quad \dots(vi)$$

$$\therefore 4\alpha - k + 8 = -4 - 4 + 8 = 0$$

\(\therefore\) Option (b) is correct.

$$\text{Now, } |P \text{ adj } (Q)| = |P||\text{adj } Q|$$

$$= 2k \left(\frac{k^2}{2}\right)^2 = \frac{k^5}{2} = \frac{2^{10}}{2} = 2^9$$

\(\therefore\) Option (c) is correct.

17. **PLAN** A square matrix M is invertible, iff $\det(M) \neq 0$ or $|M| \neq 0$.

$$\text{Let } M = \begin{bmatrix} a & b \\ b & c \end{bmatrix}$$

$$(a) \text{ Given, } \begin{bmatrix} a \\ b \end{bmatrix} = \begin{bmatrix} b \\ c \end{bmatrix} \Rightarrow a = b = c = \alpha \quad [\text{let}]$$

$$\Rightarrow M = \begin{bmatrix} \alpha & \alpha \\ \alpha & \alpha \end{bmatrix} \Rightarrow |M| = 0 \Rightarrow M \text{ is non-invertible.}$$

$$(b) \text{ Given, } [b \ c] = [a \ b]$$

$$\Rightarrow a = b = c = \alpha \quad [\text{let}]$$

$$\text{Again, } |M| = 0$$

\(\Rightarrow\) M is non-invertible.

$$(c) \text{ As given } M = \begin{bmatrix} a & 0 \\ 0 & c \end{bmatrix} \Rightarrow |M| = ac \neq 0$$

[\(\because\) a and c are non-zero]

\(\Rightarrow\) M is invertible.

$$(d) M = \begin{bmatrix} a & b \\ b & c \end{bmatrix} \Rightarrow |M| = ac - b^2 \neq 0$$

\(\therefore\) ac is not equal to square of an integer.

M is invertible.

18. **PLAN** If $|A_{n \times n}| = \Delta$, then $|\text{adj } A| = \Delta^{n-1}$

$$\text{Here, } \text{adj } P_{3 \times 3} = \begin{bmatrix} 1 & 4 & 4 \\ 2 & 1 & 7 \\ 1 & 1 & 3 \end{bmatrix}$$

$$\Rightarrow |\text{adj } P| = |P|^2$$

$$\therefore |\text{adj } P| = \begin{vmatrix} 1 & 4 & 4 \\ 2 & 1 & 7 \\ 1 & 1 & 3 \end{vmatrix} = 1(3-7) - 4(6-7) + 4(2-1)$$

$$= -4 + 4 + 4 = 4 \Rightarrow |P| = \pm 2$$

19. $|A| = (2k+1)^3, |B| = 0$

$$\text{But } \det(\text{adj } A) + \det(\text{adj } B) = 10^6$$

$$\Rightarrow (2k+1)^6 = 10^6$$

$$\Rightarrow k = \frac{9}{2} \Rightarrow [k] = 4$$

Topic 4 Solving System of Equations

1. Given system of linear equations is

$$[\sin \theta] x + [-\cos \theta] y = 0 \quad \dots(i)$$

$$\text{and } [\cot \theta] x + y = 0 \quad \dots(ii)$$

where, $[x]$ denotes the greatest integer $\leq x$.

$$\text{Here, } \Delta = \begin{vmatrix} [\sin \theta] & [-\cos \theta] \\ [\cot \theta] & 1 \end{vmatrix}$$

$$\Rightarrow \Delta = [\sin \theta] - [-\cos \theta][\cot \theta]$$

$$\text{When } \theta \in \left(\frac{\pi}{2}, \frac{2\pi}{3}\right)$$

$$\sin \theta \in \left(\frac{\sqrt{3}}{2}, 1\right)$$

$$\Rightarrow \begin{aligned} [\sin \theta] &= 0 && \dots\text{(iii)} \\ -\cos \theta &\in \left(0, \frac{1}{2}\right) \end{aligned}$$

$$\Rightarrow [-\cos \theta] = 0 \quad \dots\text{(iv)}$$

and $\cot \theta \in \left(-\frac{1}{\sqrt{3}}, 0\right)$

$$\Rightarrow [\cot \theta] = -1 \quad \dots\text{(v)}$$

So, $\Delta = [\sin \theta] - [-\cos \theta] [\cot \theta]$
 $- (0 \times (-1)) = 0$ [from Eqs. (iii), (iv) and (v)]

Thus, for $\theta \in \left(\frac{\pi}{2}, \frac{2\pi}{3}\right)$, the given system have infinitely many solutions.

When $\theta \in \left(\pi, \frac{7\pi}{6}\right)$, $\sin \theta \in \left(-\frac{1}{2}, 0\right) \Rightarrow [\sin \theta] = -1$

$$-\cos \theta \in \left(\frac{\sqrt{3}}{2}, 1\right) \Rightarrow [\cos \theta] = 0$$

and $\cot \theta \in (\sqrt{3}, \infty) \Rightarrow [\cot \theta] = n, n \in \mathbb{N}$.

So, $\Delta = -1 - (0 \times n) = -1$

Thus, for $\theta \in \left(\pi, \frac{7\pi}{6}\right)$, the given system has a unique solution.

2. Given, system of linear equations

$$x + y + z = 6 \quad \dots\text{(i)}$$

$$4x + \lambda y - \lambda z = \lambda - 2 \quad \dots\text{(ii)}$$

and $3x + 2y - 4z = -5 \quad \dots\text{(iii)}$

has infinitely many solutions, then $\Delta = 0$

$$\Rightarrow \begin{vmatrix} 1 & 1 & 1 \\ 4 & \lambda & -\lambda \\ 3 & 2 & -4 \end{vmatrix} = 0$$

$$\Rightarrow 1(-4\lambda + 2\lambda) - 1(-16 + 3\lambda) + 1(8 - 3\lambda) = 0$$

$$\Rightarrow -8\lambda + 24 = 0 \Rightarrow \lambda = 3$$

From, the option $\lambda = 3$, satisfy the quadratic equation $\lambda^2 - \lambda - 6 = 0$.

3. Given system of linear equations

$$x + y + z = 5 \quad \dots\text{(i)}$$

$$x + 2y + 2z = 6 \quad \dots\text{(ii)}$$

$$x + 3y + \lambda z = \mu \quad \dots\text{(iii)}$$

$$(\lambda, \mu \in \mathbb{R})$$

The above given system has infinitely many solutions, then the plane represented by these equations intersect each other at a line, means $(x + 3y + \lambda z - \mu) = p(x + y + z - 5) + q(x + 2y + 2z - 6)$
 $= (p + q)x + (p + 2q)y + (p + 2q)z - (5p + 6q)$

On comparing, we get

$$p + q = 1, p + 2q = 3, p + 2q = \lambda$$

and $5p + 6q = \mu$

So, $(p, q) = (-1, 2)$

$$\Rightarrow \lambda = 3 \text{ and } \mu = 7$$

$$\Rightarrow \lambda + \mu = 3 + 7 = 10$$

4. Given system of linear equations

$$2x + 3y - z = 0,$$

$$x + ky - 2z = 0$$

and $2x - y + z = 0$ has a non-trivial solution (x, y, z) .

$$\therefore \Delta = 0 \Rightarrow \begin{vmatrix} 2 & 3 & -1 \\ 1 & k & -2 \\ 2 & -1 & 1 \end{vmatrix} = 0$$

$$2(k - 2) - 3(1 + 4) - 1(-1 - 2k) = 0$$

$$\Rightarrow 2k - 4 - 15 + 1 + 2k = 0$$

$$\Rightarrow 4k = 18 \Rightarrow k = \frac{9}{2}$$

So, system of linear equations is

$$2x + 3y - z = 0 \quad \dots\text{(i)}$$

$$2x + 9y - 4z = 0 \quad \dots\text{(ii)}$$

and $2x - y + z = 0 \quad \dots\text{(iii)}$

From Eqs. (i) and (ii), we get

$$6y - 3z = 0, \frac{y}{z} = \frac{1}{2}$$

From Eqs. (i) and (iii), we get

$$4x + 2y = 0 \Rightarrow \frac{x}{y} = -\frac{1}{2}$$

So, $\frac{x}{z} = \frac{x}{y} \times \frac{y}{z} = -\frac{1}{4} \Rightarrow \frac{z}{x} = -4 \quad \left[\because \frac{y}{z} = \frac{1}{2} \text{ and } \frac{x}{y} = -\frac{1}{2} \right]$

$$\therefore \frac{x}{y} + \frac{y}{z} + \frac{z}{x} + k = -\frac{1}{2} + \frac{1}{2} - 4 + \frac{9}{2} = \frac{1}{2}$$

5. Given system of linear equations

$$x - 2y + kz = 1 \quad \dots\text{(i)}$$

$$2x + y + z = 2 \quad \dots\text{(ii)}$$

and $3x - y - kz = 3 \quad \dots\text{(iii)}$

has a solution $(x, y, z), z \neq 0$.

On adding Eqs. (i) and (iii), we get

$$x - 2y + kz + 3x - y - kz = 1 + 3$$

$$4x - 3y = 4 \Rightarrow 4x - 3y - 4 = 0$$

This is the required equation of the straight line in which point (x, y) lies.

6. Key Idea A homogeneous system of linear equations have non-trivial solutions iff $\Delta = 0$

Given system of linear equations is

$$x - cy - cz = 0,$$

$$cx - y + cz = 0$$

and $cx + cy - z = 0$

We know that a homogeneous system of linear equations have non-trivial solutions iff

$$\Rightarrow \begin{vmatrix} 1 & -c & -c \\ c & -1 & c \\ c & c & -1 \end{vmatrix} = 0$$

164 Matrices and Determinants

$$\begin{aligned}
 &\Rightarrow 1(1 - c^2) + c(-c - c^2) - c(c^2 + c) = 0 \\
 &\Rightarrow 1 - c^2 - c^2 - c^3 - c^3 - c^2 = 0 \\
 &\Rightarrow -2c^3 - 3c^2 + 1 = 0 \\
 &\Rightarrow 2c^3 + 3c^2 - 1 = 0 \\
 &\Rightarrow (c + 1)[2c^2 + c - 1] = 0 \\
 &\Rightarrow (c + 1)[2c^2 + 2c - c - 1] = 0 \\
 &\Rightarrow (c + 1)(2c - 1)(c + 1) = 0 \\
 &\Rightarrow c = -1 \text{ or } \frac{1}{2}
 \end{aligned}$$

Clearly, the greatest value of c is $\frac{1}{2}$.

7. The given system of linear equations is

$$\begin{aligned}
 x - 2y - 2z &= \lambda x \\
 x + 2y + z &= \lambda y \\
 -x - y - \lambda z &= 0,
 \end{aligned}$$

which can be rewritten as

$$\begin{aligned}
 (1 - \lambda)x - 2y - 2z &= 0 \\
 \Rightarrow x + (2 - \lambda)y + z &= 0 \\
 x + y + \lambda z &= 0
 \end{aligned}$$

Now, for non-trivial solution, we should have

$$\begin{vmatrix} 1 - \lambda & -2 & -2 \\ 1 & 2 - \lambda & 1 \\ 1 & 1 & \lambda \end{vmatrix} = 0$$

$$[\because \text{If } a_1x + b_1y + c_1z = 0; a_2x + b_2y + c_2z = 0 \\ a_3x + b_3y + c_3z = 0]$$

$$\text{has a non-trivial solution, then } \begin{vmatrix} a_1 & b_1 & c_1 \\ a_2 & b_2 & c_2 \\ a_3 & b_3 & c_3 \end{vmatrix} = 0$$

$$\begin{aligned}
 &\Rightarrow (1 - \lambda)[(2 - \lambda)\lambda - 1] + 2[\lambda - 1] - 2[1 - 2 + \lambda] = 0 \\
 &\Rightarrow (\lambda - 1)[\lambda^2 - 2\lambda + 1 + 2 - 2] = 0 \\
 &\Rightarrow (\lambda - 1)^3 = 0 \\
 &\Rightarrow \lambda = 1
 \end{aligned}$$

8. Given system of linear equations,

$$\begin{aligned}
 (1 + \alpha)x + \beta y + z &= 2 \\
 \alpha x + (1 + \beta)y + z &= 3 \\
 \alpha x + \beta y + 2z &= 2
 \end{aligned}$$

has a unique solution, if

$$\begin{vmatrix} 1 + \alpha & \beta & 1 \\ \alpha & (1 + \beta) & 1 \\ \alpha & \beta & 2 \end{vmatrix} \neq 0$$

Apply $R_1 \rightarrow R_1 - R_3$ and $R_2 \rightarrow R_2 - R_3$

$$\begin{vmatrix} 1 & 0 & -1 \\ 0 & 1 & -1 \\ \alpha & \beta & 2 \end{vmatrix} \neq 0$$

$$\Rightarrow 1(2 + \beta) - 0(0 + \alpha) - 1(0 - \alpha) \neq 0 \Rightarrow \alpha + \beta + 2 \neq 0 \dots (i)$$

Note that, only (2, 4) satisfy the Eq. (i).

9. We know that, if the system of equations

$$\begin{aligned}
 a_1x + b_1y + c_1z &= d_1 \\
 a_2x + b_2y + c_2z &= d_2 \\
 a_3x + b_3y + c_3z &= d_3
 \end{aligned}$$

has more than one solution, then $D = 0$ and $D_1 = D_2 = D_3 = 0$. In the given problem,

$$D_1 = 0 \Rightarrow \begin{vmatrix} a & 2 & 3 \\ b & -1 & 5 \\ c & -3 & 2 \end{vmatrix} = 0$$

$$\begin{aligned}
 &\Rightarrow a(-2 + 15) - 2(2b - 5c) + 3(-3b + c) = 0 \\
 &\Rightarrow 13a - 4b + 10c - 9b + 3c = 0 \\
 &\Rightarrow 13a - 13b + 13c = 0 \\
 &\Rightarrow a - b + c = 0 \Rightarrow b - a - c = 0
 \end{aligned}$$

10. We know that,

the system of linear equations

$$\begin{aligned}
 a_1x + b_1y + c_1z &= 0 \\
 a_2x + b_2y + c_2z &= 0 \\
 a_3x + b_3y + c_3z &= 0
 \end{aligned}$$

has a non-trivial solution, if

$$\begin{vmatrix} a_1 & b_1 & c_1 \\ a_2 & b_2 & c_2 \\ a_3 & b_3 & c_3 \end{vmatrix} = 0$$

Now, if the given system of linear equations

$$x + 3y + 7z = 0$$

$$-x + 4y + 7z = 0,$$

and $(\sin 3\theta)x + (\cos 2\theta)y + 2z = 0$

has non-trivial solution, then

$$\begin{vmatrix} 1 & 3 & 7 \\ -1 & 4 & 7 \\ \sin 3\theta & \cos 2\theta & 2 \end{vmatrix} = 0$$

$$\begin{aligned}
 &\Rightarrow 1(8 - 7 \cos 2\theta) - 3(-2 - 7 \sin 3\theta) \\
 &\quad + 7(-\cos 2\theta - 4 \sin 3\theta) = 0 \\
 &\Rightarrow 8 - 7 \cos 2\theta + 6 + 21 \sin 3\theta \\
 &\quad - 7 \cos 2\theta - 28 \sin 3\theta = 0 \\
 &\Rightarrow -7 \sin 3\theta - 14 \cos 2\theta + 14 = 0 \\
 &\Rightarrow -7(3 \sin \theta - 4 \sin^3 \theta) - 14(1 - 2 \sin^2 \theta) + 14 = 0
 \end{aligned}$$

$$[\because \sin 3A = 3 \sin A - 4 \sin^3 A \text{ and } \cos 2A = 1 - 2 \sin^2 A]$$

$$\begin{aligned}
 &\Rightarrow 28 \sin^3 \theta + 28 \sin^2 \theta - 21 \sin \theta - 14 + 14 = 0 \\
 &\Rightarrow 7 \sin \theta [4 \sin^2 \theta + 4 \sin \theta - 3] = 0 \\
 &\Rightarrow \sin \theta [4 \sin^2 \theta + 6 \sin \theta - 2 \sin \theta - 3] = 0 \\
 &\Rightarrow \sin \theta [2 \sin \theta (2 \sin \theta + 3) - 1(2 \sin \theta + 3)] = 0 \\
 &\Rightarrow (\sin \theta)(2 \sin \theta - 1)(2 \sin \theta + 3) = 0
 \end{aligned}$$

Now, either $\sin \theta = 0$ or $\frac{1}{2}$

$$\left[\because \sin \theta \neq -\frac{3}{2} \text{ as } -1 \leq \sin \theta \leq 1 \right]$$

In given interval $(0, \pi)$,

$$\sin \theta = \frac{1}{2}$$

$$\Rightarrow \theta = \frac{\pi}{6}, \frac{5\pi}{6} \quad [\because \sin \theta \neq 0, \theta \in (0, \pi)]$$

Hence, 2 solutions in $(0, \pi)$

11. Since, the system of equations has infinitely many solution, therefore $D = D_1 = D_2 = D_3 = 0$

Here,

$$D = \begin{vmatrix} 1 & 1 & 1 \\ 1 & 2 & 3 \\ 1 & 3 & \alpha \end{vmatrix} = 1(2\alpha - 9) - 1(\alpha - 3) + 1(3 - 2) = \alpha - 5$$

$$\text{and } D_3 = \begin{vmatrix} 1 & 1 & 5 \\ 1 & 2 & 9 \\ 1 & 3 & \beta \end{vmatrix} = 1(2\beta - 27) - 1(\beta - 9) + 5(3 - 2)$$

$$= \beta - 13$$

Now, $D = 0$

$$\Rightarrow \alpha - 5 = 0 \Rightarrow \alpha = 5$$

and $D_3 = 0 \Rightarrow \beta - 13 = 0 \Rightarrow \beta = 13$

$$\therefore \beta - \alpha = 13 - 5 = 8$$

12. Here, $D = \begin{vmatrix} 1 & -4 & 7 \\ 0 & 3 & -5 \\ -2 & 5 & -9 \end{vmatrix}$
 $= 1(-27 + 25) + 4(0 - 10) + 7(0 + 6)$
 [expanding along R_1]
 $= -2 - 40 + 42 = 0$

\therefore The system of linear equations have infinite many solutions.

[\because system is consistent and does not have unique solution as $D = 0$]

$$\Rightarrow D_1 = D_2 = D_3 = 0$$

Now, $D_1 = 0 \Rightarrow \begin{vmatrix} g & -4 & 7 \\ h & 3 & -5 \\ k & 5 & -9 \end{vmatrix} = 0$

$$\Rightarrow g(-27 + 25) + 4(-9h + 5k) + 7(5h - 3k) = 0$$

$$\Rightarrow -2g - 36h + 20k + 35h - 21k = 0$$

$$\Rightarrow -2g - h - k = 0 \Rightarrow 2g + h + k = 0$$

- 13 According to Cramer's rule, here

$$D = \begin{vmatrix} 1 & 1 & 1 \\ 2 & 3 & 2 \\ 2 & 3 & a^2 - 1 \end{vmatrix} = \begin{vmatrix} 1 & 0 & 0 \\ 2 & 1 & 0 \\ 2 & 1 & a^2 - 3 \end{vmatrix}$$

(Applying $C_2 \rightarrow C_2 - C_1$ and $C_3 \rightarrow C_3 - C_1$)
 = $a^2 - 3$ (Expanding along R_1)

and $D_1 = \begin{vmatrix} 2 & 1 & 1 \\ 5 & 3 & 2 \\ a+1 & 3 & a^2-1 \end{vmatrix} = \begin{vmatrix} 2 & 1 & 0 \\ 5 & 3 & -1 \\ a+1 & 3 & a^2-1-3 \end{vmatrix}$
 (Applying $C_3 \rightarrow C_3 - C_2$)

$$= \begin{vmatrix} 2 & 0 & 0 \\ 5 & 3 - \frac{5}{2} & -1 \\ a+1 & 3 - \frac{(a+1)}{2} & a^2-1-3 \end{vmatrix}$$

(Applying $C_2 \rightarrow C_2 - \frac{1}{2}C_1$)

$$= \begin{vmatrix} 2 & 0 & 0 \\ 5 & \frac{1}{2} & -1 \\ a+1 & \frac{5}{2} - \frac{a}{2} & a^2-4 \end{vmatrix}$$

$$= 2 \left[\frac{1}{2}(a^2-4) + \left(\frac{5}{2} - \frac{a}{2} \right) \right]$$
 [Expanding along R_1]

$$= 2 \left[\frac{a^2}{2} - 2 + \frac{5}{2} - \frac{a}{2} \right] = a^2 - 4 + 5 - a = a^2 - a + 1$$

Clearly, when $a = 4$, then $D = 13 \neq 0 \Rightarrow$ unique solution and

when $|a| = \sqrt{3}$, then $D = 0$ and $D_1 \neq 0$.

\therefore When $|a| = \sqrt{3}$, then the system has no solution i.e. system is inconsistent.

14. We have,

$$x + ky + 3z = 0; 3x + ky - 2z = 0; 2x + 4y - 3z = 0$$

System of equation has non-zero solution, if

$$\begin{vmatrix} 1 & k & 3 \\ 3 & k & -2 \\ 2 & 4 & -3 \end{vmatrix} = 0$$

$$\Rightarrow (-3k + 8) - k(-9 + 4) + 3(12 - 2k) = 0$$

$$\Rightarrow -3k + 8 + 9k - 4k + 36 - 6k = 0$$

$$\Rightarrow -4k + 44 = 0 \Rightarrow k = 11$$

Let $z = \lambda$, then we get

$$x + 11y + 3\lambda = 0 \quad \dots(i)$$

$$3x + 11y - 2\lambda = 0 \quad \dots(ii)$$

and $2x + 4y - 3\lambda = 0 \quad \dots(iii)$

Solving Eqs. (i) and (ii), we get

$$x = \frac{5\lambda}{2}, y = \frac{-\lambda}{2}, z = \lambda \Rightarrow \frac{xz}{y^2} = \frac{5\lambda^2}{2 \times \left(\frac{-\lambda}{2} \right)^2} = 10$$

15. Given, system of linear equation is

$$x + \lambda y - z = 0; \lambda x - y - z = 0; x + y - \lambda z = 0$$

Note that, given system will have a non-trivial solution only if determinant of coefficient matrix is zero,

i.e. $\begin{vmatrix} 1 & \lambda & -1 \\ \lambda & -1 & -1 \\ 1 & 1 & -\lambda \end{vmatrix} = 0$

$$\Rightarrow 1(\lambda + 1) - \lambda(-\lambda^2 + 1) - 1(\lambda + 1) = 0$$

$$\Rightarrow \lambda + 1 + \lambda^3 - \lambda - \lambda - 1 = 0$$

$$\Rightarrow \lambda^3 - \lambda = 0 \Rightarrow \lambda(\lambda^2 - 1) = 0$$

$$\Rightarrow \lambda = 0 \text{ or } \lambda = \pm 1$$

Hence, given system of linear equation has a non-trivial solution for exactly three values of λ .

16. Given system of linear equations

$$2x_1 - 2x_2 + x_3 = \lambda x_1 \quad \dots(i)$$

$$\Rightarrow (2 - \lambda)x_1 - 2x_2 + x_3 = 0 \quad \dots(ii)$$

$$2x_1 - 3x_2 + 2x_3 = \lambda x_2 \quad \dots(iii)$$

166 Matrices and Determinants

$$\begin{aligned} \Rightarrow 2x_1 - (3 + \lambda)x_2 + 2x_3 &= 0 \\ -x_1 + 2x_2 &= \lambda x_3 \Rightarrow -x_1 + 2x_2 - \lambda x_3 = 0 \end{aligned}$$

Since, the system has non-trivial solution.

$$\therefore \begin{bmatrix} 2-\lambda & -2 & 1 \\ 2 & -(3+\lambda) & 2 \\ -1 & 2 & \lambda \end{bmatrix} = 0$$

$$\begin{aligned} \Rightarrow (2-\lambda)(3\lambda + \lambda^2 - 4) + 2(-2\lambda + 2) + 1(4-3) - \lambda &= 0 \\ \Rightarrow (2-\lambda)(\lambda^2 + 3\lambda - 4) + 4(1-\lambda) + (1-\lambda) &= 0 \\ \Rightarrow (2-\lambda)(\lambda + 4)(\lambda - 1) + 5(1-\lambda) &= 0 \\ \Rightarrow (\lambda - 1)[(2-\lambda)(\lambda + 4) - 5] &= 0 \\ \Rightarrow (\lambda - 1)(\lambda^2 + 2\lambda - 3) &= 0 \\ \Rightarrow (\lambda - 1)[(\lambda - 1)(\lambda + 8)] &= 0 \\ \Rightarrow (\lambda - 1)^2(\lambda + 3) &= 0 \\ \Rightarrow \lambda = 1, 1, -3 \end{aligned}$$

Hence, λ contains two elements.

17. Given equations can be written in matrix form

$$AX = B$$

$$\text{where, } A = \begin{bmatrix} k+1 & 8 \\ k & k+3 \end{bmatrix}, X = \begin{bmatrix} x \\ y \end{bmatrix} \text{ and } B = \frac{4k}{3k-1}$$

For no solution, $|A|=0$ and $(\text{adj } A)B \neq 0$

$$\text{Now, } |A| = \begin{vmatrix} k+1 & 8 \\ k & k+3 \end{vmatrix} = 0 \Rightarrow (k^2+1)(k+3) - 8k = 0$$

$$\begin{aligned} k^2 + 4k + 3 - 8k &= 0 \Rightarrow k^2 - 4k + 3 = 0 \\ \Rightarrow (k-1)(k-3) &= 0 \Rightarrow k=1, k=3, \end{aligned}$$

$$\text{Now } \text{adj } A = \begin{bmatrix} k+3 & -8 \\ -k & k+1 \end{bmatrix}$$

$$\begin{aligned} \text{Now, } (\text{adj } A)B &= \begin{bmatrix} k+3 & -8 \\ -k & k+1 \end{bmatrix} \begin{bmatrix} 4k \\ 3k+1 \end{bmatrix} \\ &= \begin{bmatrix} (k+3)(4k) & -8(3k-1) \\ -4k^2 & (k+1)(3k-1) \end{bmatrix} \\ &= \begin{bmatrix} 4k^2 - 12k + 8 \\ -k^2 + 2k - 1 \end{bmatrix} \end{aligned}$$

Put $k=1$

$$(\text{adj } A)B = \begin{bmatrix} 4-12+8 \\ -1+2-1 \end{bmatrix} = \begin{bmatrix} 0 \\ 0 \end{bmatrix} \text{ not true}$$

Put $k=3$

$$(\text{adj } A)B = \begin{bmatrix} 36-36+8 \\ -9+6-1 \end{bmatrix} = \begin{bmatrix} 8 \\ -4 \end{bmatrix} \neq 0 \text{ true}$$

Hence, required value of k is 3.

Alternate Solution

Condition for the system of equations has no solution is

$$\frac{a_1}{a_2} = \frac{b_1}{b_2} \neq \frac{c_1}{c_2}$$

$$\therefore \frac{k+1}{k} = \frac{8}{k+3} \neq \frac{4k}{3k-1}$$

$$\text{Take } \frac{k+1}{k} = \frac{8}{k+3} \Rightarrow k^2 + 4k + 3 = 8k$$

$$\begin{aligned} \Rightarrow k^2 - 4k + 3 &\Rightarrow (k-1)(k-3) = 0 \\ k &= 1, 3 \end{aligned}$$

$$\text{If } k=1, \text{ then } \frac{8}{1+3} \neq \frac{4 \cdot 1}{2}, \text{ false}$$

$$\text{And, if } k=3, \text{ then } \frac{8}{6} \neq \frac{4 \cdot 3}{9-1}, \text{ true}$$

Therefore, $k=3$

Hence, only one value of k exist.

18. Since, $A \begin{bmatrix} x \\ y \\ z \end{bmatrix} = \begin{bmatrix} 1 \\ 0 \\ 0 \end{bmatrix}$ is linear equation in three variables

and that could have only unique, no solution or infinitely many solution.

\therefore It is not possible to have two solutions.

Hence, number of matrices A is zero.

19. Since, given system has no solution.

$\therefore \Delta = 0$ and any one amongst $\Delta_x, \Delta_y, \Delta_z$ is non-zero.

$$\text{Let } \begin{vmatrix} 2 & -1 & 2 \\ 1 & -2 & 1 \\ 1 & 1 & \lambda \end{vmatrix} = 0 \text{ and } \Delta_z = \begin{vmatrix} 2 & -1 & 2 \\ 1 & -2 & -4 \\ 1 & 1 & 4 \end{vmatrix} = 6 \neq 0$$

$$\Rightarrow \lambda = 1$$

20. For infinitely many solutions, we must have

$$\frac{k+1}{k} = \frac{8}{k+3} = \frac{4k}{3k-1} \Rightarrow k=1$$

21. Given equations $x + ay = 0, az + y = 0, ax + z = 0$ has infinite solutions.

$$\therefore \begin{vmatrix} 1 & a & 0 \\ 0 & 1 & a \\ a & 0 & 1 \end{vmatrix} = 0$$

$$\Rightarrow 1 + a^3 = 0 \text{ or } a = -1$$

22. Since, the given system has non-zero solution.

$$\therefore \begin{vmatrix} 1 & -k & -1 \\ k & -1 & -1 \\ 1 & 1 & -1 \end{vmatrix} = 0$$

Applying $C_1 \rightarrow C_1 - C_2, C_2 \rightarrow C_2 + C_3$

$$\Rightarrow \begin{vmatrix} 1+k & -k-1 & -1 \\ 1+k & -2 & -1 \\ 0 & 0 & -1 \end{vmatrix} = 0$$

$$\Rightarrow 2(k+1) - (k+1)^2 = 0$$

$$\Rightarrow (k+1)(2-k-1) = 0$$

$$\Rightarrow k = \pm 1$$

NOTE There is a golden rule in determinant that n one's $\Rightarrow (n-1)$ zero's or n (constant) $\Rightarrow (n-1)$ zero's for all constant should be in a single row or a single column.

23. The given system of equations can be expressed as

$$\begin{bmatrix} 1 & -2 & 3 \\ 1 & -3 & 4 \\ -1 & 1 & -2 \end{bmatrix} \begin{bmatrix} x \\ y \\ z \end{bmatrix} = \begin{bmatrix} -1 \\ 1 \\ k \end{bmatrix}$$

Applying $R_2 \rightarrow R_2 - R_1, R_3 \rightarrow R_3 + R_1$

$$\sim \begin{bmatrix} 1 & -2 & 3 \\ 0 & -1 & 1 \\ 0 & -1 & 1 \end{bmatrix} \begin{bmatrix} x \\ y \\ z \end{bmatrix} = \begin{bmatrix} -1 \\ 2 \\ k-1 \end{bmatrix}$$

Applying $R_3 \rightarrow R_3 - R_2$

$$\sim \begin{bmatrix} 1 & -2 & 3 \\ 0 & -1 & 1 \\ 0 & 0 & 0 \end{bmatrix} \begin{bmatrix} x \\ y \\ z \end{bmatrix} = \begin{bmatrix} -1 \\ 2 \\ k-3 \end{bmatrix}$$

When $k \neq 3$, the given system of equations has no solution.

\Rightarrow Statement I is true. Clearly, Statement II is also true as it is rearrangement of rows and columns of

$$\begin{bmatrix} 1 & -2 & 3 \\ 1 & -3 & 4 \\ -1 & 1 & -2 \end{bmatrix}$$

24. It is given, that matrices

$$P = \begin{bmatrix} 1 & 1 & 1 \\ 0 & 2 & 2 \\ 0 & 0 & 3 \end{bmatrix}, Q = \begin{bmatrix} 2 & x & x \\ 0 & 4 & 0 \\ x & x & 6 \end{bmatrix}$$

$$\therefore P^{-1} = \frac{\text{adj}(P)}{|P|}$$

as $|P| = 6$ and $\text{adj } P = \begin{bmatrix} 6 & 0 & 0 \\ -3 & 3 & 0 \\ 0 & -2 & 2 \end{bmatrix}^T$

$$\Rightarrow P^{-1} = \frac{1}{6} \begin{bmatrix} 6 & -3 & 0 \\ 0 & 3 & -2 \\ 0 & 0 & 2 \end{bmatrix}$$

$$\therefore |R| = |PQP^{-1}| \quad [:\because R = PQP^{-1} \text{ (given)}]$$

$$\Rightarrow |R| = |P||Q||P^{-1}| = |Q| \quad [:\because |P||P^{-1}| = |I| = 1]$$

$$= \begin{vmatrix} 2 & x & x \\ 0 & 4 & 0 \\ x & x & 6 \end{vmatrix} = \begin{vmatrix} 2 & x & x \\ 0 & 4 & 0 \\ x & x & 5 \end{vmatrix} + \begin{vmatrix} 2 & x & 0 \\ 0 & 4 & 0 \\ x & x & 1 \end{vmatrix}$$

$$= \begin{vmatrix} 2 & x & x \\ 0 & 4 & 0 \\ x & x & 5 \end{vmatrix} + 2(4-0) - x(0-0) + 0(0-4x)$$

$$= \begin{vmatrix} 2 & x & x \\ 0 & 4 & 0 \\ x & x & 5 \end{vmatrix} + 8 \text{ for all } x \in R$$

$$\therefore PQ = \begin{bmatrix} 1 & 1 & 1 \\ 0 & 2 & 2 \\ 0 & 0 & 3 \end{bmatrix} \begin{bmatrix} 2 & x & x \\ 0 & 4 & 0 \\ x & x & 6 \end{bmatrix}$$

$$= \begin{bmatrix} 2+x & 4+2x & x+6 \\ 2x & 2x+8 & 12 \\ 3x & 3x & 18 \end{bmatrix}$$

and $QP = \begin{bmatrix} 2 & x & x \\ 0 & 4 & 0 \\ x & x & 6 \end{bmatrix} \begin{bmatrix} 1 & 1 & 1 \\ 0 & 2 & 2 \\ 0 & 0 & 3 \end{bmatrix}$

$$= \begin{bmatrix} 2 & 2+2x & 2+5x \\ 0 & 8 & 8 \\ x & 3x & 3x+18 \end{bmatrix}$$

There is no common value of 'x', for which each corresponding element of matrices PQ and QP is equal.

For $x=0, Q = \begin{bmatrix} 2 & 0 & 0 \\ 0 & 4 & 0 \\ 0 & 0 & 6 \end{bmatrix}$

then, if $R \begin{bmatrix} 1 \\ a \\ b \end{bmatrix} = 6 \begin{bmatrix} 1 \\ a \\ b \end{bmatrix}$

$$\Rightarrow PQP^{-1} \begin{bmatrix} 1 \\ a \\ b \end{bmatrix} = 6 \begin{bmatrix} 1 \\ a \\ b \end{bmatrix} \quad [:\because R = PQP^{-1}]$$

$$\Rightarrow \frac{1}{6} \begin{bmatrix} 1 & 1 & 1 \\ 0 & 2 & 2 \\ 0 & 0 & 3 \end{bmatrix} \begin{bmatrix} 2 & 0 & 0 \\ 0 & 4 & 0 \\ 0 & 0 & 6 \end{bmatrix} \begin{bmatrix} 6 & -3 & 0 \\ 0 & 3 & -2 \\ 0 & 0 & 2 \end{bmatrix} \begin{bmatrix} 1 \\ a \\ b \end{bmatrix} = 6 \begin{bmatrix} 1 \\ a \\ b \end{bmatrix}$$

$$\Rightarrow \frac{1}{6} \begin{bmatrix} 2 & 4 & 6 \\ 0 & 8 & 12 \\ 0 & 0 & 18 \end{bmatrix} \begin{bmatrix} 6 & -3 & 0 \\ 0 & 3 & -2 \\ 0 & 0 & 2 \end{bmatrix} \begin{bmatrix} 1 \\ a \\ b \end{bmatrix} = 6 \begin{bmatrix} 1 \\ a \\ b \end{bmatrix}$$

$$\Rightarrow \begin{bmatrix} 12 & 6 & 4 \\ 0 & 24 & 8 \\ 0 & 0 & 36 \end{bmatrix} \begin{bmatrix} 1 \\ a \\ b \end{bmatrix} = 36 \begin{bmatrix} 1 \\ a \\ b \end{bmatrix}$$

$$\Rightarrow \begin{bmatrix} 12+6a+4b \\ 0+24a+8b \\ 0+0+36b \end{bmatrix} = \begin{bmatrix} 36 \\ 36a \\ 36b \end{bmatrix}$$

$$\Rightarrow 6a+4b=24 \text{ and } 12a=8b$$

$$\Rightarrow 3a+2b=12 \text{ and } 3a=2b$$

$$\Rightarrow a=2 \text{ and } b=3$$

So $a+b=5$.

Now, $R \begin{bmatrix} \alpha \\ \beta \\ \gamma \end{bmatrix} = \begin{bmatrix} 0 \\ 0 \\ 0 \end{bmatrix}$ and $\alpha\hat{i} + \beta\hat{j} + \gamma\hat{k}$ is a unit vector, so \det

$$(R) = 0$$

$$\Rightarrow \det(Q) = 0 \quad [:\because R = PQP^{-1} \text{ So, } |R|=|Q|]$$

$$\Rightarrow \begin{vmatrix} 2 & x & x \\ 0 & 4 & 0 \\ x & x & 6 \end{vmatrix} = 0$$

$$\Rightarrow 2(24-0) - x(0-0) + x(0-4x)$$

$$\Rightarrow 48 - 4x^2 = 0$$

$$\Rightarrow x^2 = 12$$

$$\Rightarrow x = \pm 2\sqrt{3}$$

So, for $x=1$, there does not exist a unit vector

$$\alpha\hat{i} + \beta\hat{j} + \gamma\hat{k}, \text{ for which } R \begin{bmatrix} \alpha \\ \beta \\ \gamma \end{bmatrix} = \begin{bmatrix} 0 \\ 0 \\ 0 \end{bmatrix}$$

Hence, options (b) and (d) are correct.

168 Matrices and Determinants

25. We have,

$$\begin{aligned} -x + 2y + 5z &= b_1 \\ 2x - 4y + 3z &= b_2 \\ x - 2y + 2z &= b_3 \end{aligned}$$

has at least one solution.

$$\therefore D = \begin{vmatrix} -1 & 2 & 5 \\ 2 & -4 & 3 \\ 1 & -2 & 2 \end{vmatrix}$$

and $D_1 = D_2 = D_3 = 0$

$$\Rightarrow D_1 = \begin{vmatrix} b_1 & 2 & 5 \\ b_2 & -4 & 3 \\ b_3 & -2 & 2 \end{vmatrix}$$

$$= -2b_1 - 14b_2 + 26b_3 = 0$$

$$\Rightarrow b_1 + 7b_2 = 13b_3 \quad \dots(i)$$

$$(a) D = \begin{vmatrix} 1 & 2 & 3 \\ 0 & 4 & 5 \\ 1 & 2 & 6 \end{vmatrix} = 1(24 - 10) + 1(10 - 12)$$

$$= 14 - 2 = 12 \neq 0$$

Here, $D \neq 0 \Rightarrow$ unique solution for any b_1, b_2, b_3 .

$$(b) D = \begin{vmatrix} 1 & 1 & 3 \\ 5 & 2 & 6 \\ -2 & -1 & -3 \end{vmatrix}$$

$$= 1(-6 + 6) - 1(-15 + 12) + 3(-5 + 4) = 0$$

For atleast one solution

$$D_1 = D_2 = D_3 = 0$$

$$\text{Now, } D_1 = \begin{vmatrix} b_1 & 1 & 3 \\ b_2 & 2 & 6 \\ b_3 & -1 & -3 \end{vmatrix}$$

$$= b_1(-6 + 6) - b_2(-3 + 3) + b_3(6 - 6) = 0$$

$$D_2 = \begin{vmatrix} 1 & b_1 & 3 \\ 5 & b_2 & 6 \\ -2 & b_3 & -3 \end{vmatrix}$$

$$= -b_1(-15 + 12) + b_2(-3 + 6) - b_3(6 - 15)$$

$$= 3b_1 + 3b_2 + 9b_3 = 0 \Rightarrow b_1 + b_2 + 3b_3 = 0$$

not satisfies the Eq. (i)

It has no solution.

$$(c) D = \begin{vmatrix} -1 & 2 & -5 \\ 2 & -4 & 10 \\ 1 & -2 & 5 \end{vmatrix}$$

$$= -1(-20 + 20) - 2(10 - 10) - 5(-4 + 4) = 0$$

Here, $b_2 = -2b_1$ and $b_3 = -b_1$ satisfies the Eq. (i)

Planes are parallel.

$$(d) D = \begin{vmatrix} 1 & 2 & 5 \\ 2 & 0 & 3 \\ 1 & 4 & -5 \end{vmatrix} = 1(0 - 12) - 2(-10 - 3) + 5(8 - 0)$$

$$= 54$$

$$D \neq 0$$

It has unique solution for any b_1, b_2, b_3 .

26. Given system $\lambda x + y + z = 0, -x + \lambda y + z = 0$

and $-x - y + \lambda z = 0$

will have non-zero solution, if

$$\begin{vmatrix} \lambda & 1 & 1 \\ -1 & \lambda & 1 \\ -1 & -1 & \lambda \end{vmatrix} = 0$$

$$\Rightarrow \lambda(\lambda^2 + 1) - 1(-\lambda + 1) + 1(1 + \lambda) = 0$$

$$\Rightarrow \lambda^3 + \lambda + \lambda - 1 + 1 + \lambda = 0$$

$$\Rightarrow \lambda^3 + 3\lambda = 0$$

$$\Rightarrow \lambda(\lambda^2 + 3) = 0 \Rightarrow \lambda = 0$$

27. Since, $AX = U$ has infinitely many solutions.

$$\Rightarrow |A| = 0 \Rightarrow \begin{vmatrix} a & 0 & 1 \\ 1 & c & b \\ 1 & d & b \end{vmatrix} = 0$$

$$\Rightarrow a(bc - bd) + 1(d - c) = 0 \Rightarrow (d - c)(ab - 1) = 0$$

$$\therefore ab = 1 \text{ or } d = c$$

$$\text{Again, } |A_3| = \begin{vmatrix} a & 0 & f \\ 1 & c & g \\ 1 & d & h \end{vmatrix} = 0 \Rightarrow g = h$$

$$\Rightarrow |A_2| = \begin{vmatrix} a & f & 1 \\ 1 & g & b \\ 1 & h & b \end{vmatrix} = 0 \Rightarrow g = h$$

$$\text{and } |A_1| = \begin{vmatrix} f & 0 & 1 \\ g & c & b \\ h & d & b \end{vmatrix} = 0 \Rightarrow g = h$$

$$\therefore g = h, c = d \text{ and } ab = 1 \quad \dots(i)$$

Now, $BX = V$

$$|B| = \begin{vmatrix} a & 1 & 1 \\ 0 & d & c \\ f & g & h \end{vmatrix} = 0 \quad [\text{from Eq. (i)}]$$

[since, C_2 and C_3 are equal]

$\therefore BX = V$ has no solution.

$$|B_1| = \begin{vmatrix} a^2 & 1 & 1 \\ 0 & d & c \\ 0 & g & h \end{vmatrix} = 0 \quad [\text{from Eq. (i)}]$$

[since, $c = d$ and $g = h$]

$$|B_2| = \begin{vmatrix} a & a^2 & 1 \\ 0 & 0 & c \\ f & 0 & h \end{vmatrix} = a^2cf = a^2df \quad [\because c = d]$$

Since, $adf \neq 0 \Rightarrow |B_2| \neq 0$

$$|B| = 0 \text{ and } |B_2| \neq 0$$

$\therefore BX = V$ has no solution.

28. Given, $\lambda x + (\sin \alpha) y + (\cos \alpha) z = 0$

$$x + (\cos \alpha) y + (\sin \alpha) z = 0$$

and $-x + (\sin \alpha) y - (\cos \alpha) z = 0$ has non-trivial solution.

$$\therefore \Delta = 0$$

$$\Rightarrow \begin{vmatrix} \lambda & \sin \alpha & \cos \alpha \\ 1 & \cos \alpha & \sin \alpha \\ -1 & \sin \alpha & -\cos \alpha \end{vmatrix} = 0$$

$$\begin{aligned} \Rightarrow \lambda (-\cos^2 \alpha - \sin^2 \alpha) - \sin \alpha (-\cos \alpha + \sin \alpha) \\ + \cos \alpha (\sin \alpha + \cos \alpha) = 0 \\ \Rightarrow -\lambda + \sin \alpha \cos \alpha + \sin \alpha \cos \alpha - \sin^2 \alpha + \cos^2 \alpha = 0 \\ \Rightarrow \lambda = \cos 2\alpha + \sin 2\alpha \\ \left[\because -\sqrt{a^2 + b^2} \leq a \sin \theta + b \cos \theta \leq \sqrt{a^2 + b^2} \right] \\ \therefore -\sqrt{2} \leq \lambda \leq \sqrt{2} \quad \dots(i) \end{aligned}$$

Again, when $\lambda = 1$, $\cos 2\alpha + \sin 2\alpha = 1$

$$\begin{aligned} \Rightarrow \frac{1}{\sqrt{2}} \cos 2\alpha + \frac{1}{\sqrt{2}} \sin 2\alpha = \frac{1}{\sqrt{2}} \\ \Rightarrow \cos (2\alpha - \pi/4) = \cos \pi/4 \\ \therefore 2\alpha - \pi/4 = 2n\pi \pm \pi/4 \\ \Rightarrow 2\alpha = 2n\pi - \pi/4 + \pi/4 \text{ or } 2\alpha = 2n\pi + \pi/4 + \pi/4 \\ \therefore \alpha = n\pi \text{ or } n\pi + \pi/4 \end{aligned}$$

29. Since, α_1, α_2 are the roots of $ax^2 + bx + c = 0$.

$$\Rightarrow \alpha_1 + \alpha_2 = -\frac{b}{a} \text{ and } \alpha_1\alpha_2 = \frac{c}{a} \quad \dots(i)$$

Also, β_1, β_2 are the roots of $px^2 + qx + r = 0$.

$$\Rightarrow \beta_1 + \beta_2 = -\frac{q}{p} \text{ and } \beta_1\beta_2 = \frac{r}{p} \quad \dots(ii)$$

Given system of equations

$$\alpha_1 y + \alpha_2 z = 0$$

and $\beta_1 y + \beta_2 z = 0$, has non-trivial solution.

$$\therefore \begin{vmatrix} \alpha_1 & \alpha_2 \\ \beta_1 & \beta_2 \end{vmatrix} = 0 \Rightarrow \frac{\alpha_1}{\alpha_2} = \frac{\beta_1}{\beta_2}$$

Applying componendo-dividendo, $\frac{\alpha_1 + \alpha_2}{\alpha_1 - \alpha_2} = \frac{\beta_1 + \beta_2}{\beta_1 - \beta_2}$

$$\begin{aligned} \Rightarrow (\alpha_1 + \alpha_2)(\beta_1 - \beta_2) &= (\alpha_1 - \alpha_2)(\beta_1 + \beta_2) \\ \Rightarrow (\alpha_1 + \alpha_2)^2 \{(\beta_1 + \beta_2)^2 - 4\beta_1\beta_2\} \\ &= (\beta_1 + \beta_2)^2 \{(\alpha_1 + \alpha_2)^2 - 4\alpha_1\alpha_2\} \end{aligned}$$

From Eqs. (i) and (ii), we get

$$\frac{b^2}{a^2} \left(\frac{q^2}{p^2} - \frac{4r}{p} \right) = \frac{q^2}{p^2} \left(\frac{b^2}{a^2} - \frac{4c}{a} \right)$$

$$\Rightarrow \frac{b^2 q^2}{a^2 p^2} - \frac{4b^2 r}{a^2 p} = \frac{b^2 q^2}{a^2 p^2} - \frac{4q^2 c}{ap^2}$$

$$\Rightarrow \frac{b^2 r}{a} = \frac{q^2 c}{p} \Rightarrow \frac{b^2}{q^2} = \frac{ac}{pr}$$

30. The system of equations has non-trivial solution, if $\Delta = 0$.

$$\Rightarrow \begin{vmatrix} \sin 3\theta & -1 & 1 \\ \cos 2\theta & 4 & 3 \\ 2 & 7 & 7 \end{vmatrix} = 0$$

Expanding along C_1 , we get

$$\begin{aligned} \sin 3\theta \cdot (28 - 21) - \cos 2\theta (-7 - 7) + 2(-3 - 4) &= 0 \\ \Rightarrow 7 \sin 3\theta + 14 \cos 2\theta - 14 &= 0 \\ \Rightarrow \sin 3\theta + 2 \cos 2\theta - 2 &= 0 \\ \Rightarrow 3 \sin \theta - 4 \sin^3 \theta + 2(1 - 2 \sin^2 \theta) - 2 &= 0 \end{aligned}$$

$$\begin{aligned} \Rightarrow \sin \theta (4 \sin^2 \theta + 4 \sin \theta - 3) &= 0 \\ \Rightarrow \sin \theta (2 \sin \theta - 1)(2 \sin \theta + 3) &= 0 \\ \Rightarrow \sin \theta = 0, \sin \theta = \frac{1}{2} \\ & \text{[neglecting } \sin \theta = -3/2] \\ \Rightarrow \theta = n\pi, n\pi + (-1)^n \frac{\pi}{6}, n \in Z \end{aligned}$$

31. The given system of equations

$$\begin{aligned} 3x - y + 4z &= 3 \\ x + 2y - 3z &= -2 \\ 6x + 5y + \lambda z &= -3 \end{aligned}$$

has atleast one solution, if $\Delta \neq 0$.

$$\therefore \Delta = \begin{vmatrix} 3 & -1 & 4 \\ 1 & 2 & -3 \\ 6 & 5 & \lambda \end{vmatrix} \neq 0$$

$$\Rightarrow 3(2\lambda + 15) + 1(\lambda + 18) + 4(5 - 12) \neq 0$$

$$\Rightarrow 7(\lambda + 5) \neq 0 \Rightarrow \lambda \neq -5$$

Let $z = -k$, then equations become

$$3x - y = 3 - 4k \text{ and } x + 2y = 3k - 2$$

On solving, we get

$$x = \frac{4 - 5k}{7}, y = \frac{13k - 9}{7}, z = k$$

32. Given system of equations are

$$3x + my = m \text{ and } 2x - 5y = 20$$

Here,

$$\Delta = \begin{vmatrix} 3 & m \\ 2 & -5 \end{vmatrix} = -15 - 2m$$

and

$$\Delta_x = \begin{vmatrix} m & m \\ 20 & -5 \end{vmatrix} = -25m$$

$$\Delta_y = \begin{vmatrix} 3 & m \\ 2 & 20 \end{vmatrix} = 60 - 2m$$

If $\Delta = 0$, then system is inconsistent, i.e. it has no solution.

If $\Delta \neq 0$, i.e. $m \neq \frac{15}{2}$, the system has a unique solution for any fixed value of m .

We have, $x = \frac{\Delta_x}{\Delta} = \frac{-25m}{-15 - 2m} = \frac{25m}{15 + 2m}$

and $y = \frac{\Delta_y}{\Delta} = \frac{60 - 2m}{-15 - 2m} = \frac{2m - 60}{15 + 2m}$

For $x > 0$, $\frac{25m}{15 + 2m} > 0 \Rightarrow m > 0$

or $m < -\frac{15}{2}$... (i)

and $y > 0$, $\frac{2m - 60}{2m + 15} > 0$

$$\Rightarrow m > 30 \text{ or } m < -\frac{15}{2} \quad \dots(ii)$$

From Eqs. (i) and (ii), we get $m < -\frac{15}{2}$ or $m > 30$

170 Matrices and Determinants

33. Since, the given system of equations posses non-trivial

$$\text{solution, if } \begin{vmatrix} 0 & 1 & -2 \\ 0 & -3 & 1 \\ k & -5 & 4 \end{vmatrix} = 0 \Rightarrow k = 0$$

On solving the equations $x = y = z = \lambda$ [say]

\therefore For $k = 0$, the system has infinite solutions of $\lambda \in R$.

34. Given systems of equations can be rewritten as
 $-x + cy + by = 0$, $cx - y + az = 0$ and $bx + ay - z = 0$

Above system of equations are homogeneous equation. Since, x, y and z are not all zero, so it has non-trivial solution.

Therefore, the coefficient of determinant must be zero.

$$\therefore \begin{vmatrix} -1 & c & b \\ c & -1 & a \\ b & a & -1 \end{vmatrix} = 0$$

$$\Rightarrow -1(1 - a^2) - c(-c - ab) + b(ca + b) = 0$$

$$\Rightarrow a^2 + b^2 + c^2 + 2abc - 1 = 0$$

$$\Rightarrow a^2 + b^2 + c^2 + 2abc = 1$$

35. System of given linear equations is

$$x - 2y + 3z = 9$$

$$2x + y + z = b$$

and $x - 7y + az = 24$, has infinitely many solution, so

$$\Delta = 0 = \Delta_1 = \Delta_2 = \Delta_3$$

$$\text{So, } \Delta = 0$$

$$\Rightarrow \begin{vmatrix} 1 & -2 & 3 \\ 2 & 1 & 1 \\ 1 & -7 & a \end{vmatrix} = 0$$

$$\Rightarrow 1(a + 7) + 2(2a - 1) + 3(-14 - 1) = 0$$

$$\Rightarrow 5a = 40 \Rightarrow a = 8$$

$$\text{and } \Delta_3 = 0 \Rightarrow \begin{vmatrix} 1 & -2 & 9 \\ 2 & 1 & b \\ 1 & -7 & 24 \end{vmatrix} = 0$$

$$\Rightarrow 1(24 + 7b) + 2(48 - b) + 9(-14 - 1) = 0$$

$$\Rightarrow 5b + 120 - 135 = 0 \Rightarrow b = 3$$

$$\therefore a - b = 8 - 3 = 5$$

Hence, answer is 5.00.

36. The given system of linear equations

$$x + y + z = 6,$$

$$x + 2y + 3z = 10,$$

and $3x + 2y + \lambda z = \mu$ has more than two solutions, so system must have infinite number of solutions.

Now, on putting $z = 0$ in above equation, we get

$$x + y = 6 \quad \dots(i)$$

$$x + 2y = 10 \quad \dots(ii)$$

$$\text{and } 3x + 2y = \mu \quad \dots(iii)$$

On solving Eqs. (i) and (ii), we are getting

$$y = 4 \text{ and } x = 2$$

From Eq. (iii), we get

$$\mu = 3(2) + 2(4) = 14$$

Now, on putting $y = 0$ and $\mu = 14$, in the given system of linear Eq., we get

$$x + z = 6 \quad \dots(iv)$$

$$x + 3z = 10 \quad \dots(v)$$

$$\text{and } 3x + \lambda z = 14 \quad \dots(vi)$$

On solving Eqs. (iv) and (v), we get $z = 2$ and $x = 4$

From Eq. (vi), we get

$$3(4) + \lambda(2) = 14$$

$$\Rightarrow \lambda = 1$$

$$\therefore \mu - \lambda^2 = 14 - 1 = 13$$

$$37. \begin{vmatrix} 1 & \alpha & \alpha^2 \\ \alpha & 1 & \alpha \\ \alpha^2 & \alpha & 1 \end{vmatrix} = 0$$

$$\Rightarrow \alpha^4 - 2\alpha^2 + 1 = 0$$

$$\Rightarrow \alpha^2 = 1 \Rightarrow \alpha = \pm 1$$

But $\alpha = 1$ not possible [Not satisfying equation]

$$\therefore \alpha = -1$$

$$\text{Hence, } 1 + \alpha + \alpha^2 = 1$$

$$38. \text{ Let } M = \begin{bmatrix} a_1 & a_2 & a_3 \\ b_1 & b_2 & b_3 \\ c_1 & c_2 & c_3 \end{bmatrix}$$

$$\therefore M \begin{bmatrix} 0 \\ 1 \\ 0 \end{bmatrix} = \begin{bmatrix} -1 \\ 2 \\ 3 \end{bmatrix} \Rightarrow M \begin{bmatrix} 1 \\ -1 \\ 0 \end{bmatrix} = \begin{bmatrix} 1 \\ 1 \\ -1 \end{bmatrix}$$

$$M \begin{bmatrix} 1 \\ 1 \\ 1 \end{bmatrix} = \begin{bmatrix} 0 \\ 0 \\ 12 \end{bmatrix} \Rightarrow \begin{bmatrix} a_2 \\ b_2 \\ c_2 \end{bmatrix} = \begin{bmatrix} -1 \\ 2 \\ 3 \end{bmatrix}, \begin{bmatrix} a_1 - a_2 \\ b_1 - b_2 \\ c_1 - c_2 \end{bmatrix} = \begin{bmatrix} 1 \\ 1 \\ -1 \end{bmatrix},$$

$$\begin{bmatrix} a_1 + a_2 + a_3 \\ b_1 + b_2 + b_3 \\ c_1 + c_2 + c_3 \end{bmatrix} = \begin{bmatrix} 0 \\ 0 \\ 12 \end{bmatrix}$$

$$\Rightarrow a_2 = -1, b_2 = 2, c_2 = 3, a_1 - a_2 = 1, b_1 - b_2 = 1, c_1 - c_2 = -1$$

$$\Rightarrow a_1 + a_2 + a_3 = 0, b_1 + b_2 + b_3 = 0$$

$$c_1 + c_2 + c_3 = 12$$

$$\therefore a_1 = 0, b_2 = 2, c_3 = 7$$

$$\Rightarrow \text{Sum of diagonal elements} = 0 + 2 + 7 = 9$$

8

Functions

Topic 1 Classification of Functions, Domain and Range and Even, Odd Functions

Objective Questions I (Only one correct option)

1. If $R = \{(x, y) : x, y \in Z, x^2 + 3y^2 \leq 8\}$ is a relation on the set of integers Z , then the domain of R^{-1} is

(2020 Main, 2 Sep I)

- (a) $\{-1, 0, 1\}$ (b) $\{-2, -1, 1, 2\}$
 (c) $\{-2, -1, 0, 1, 2\}$ (d) $\{0, 1\}$

2. The domain of the definition of the function

$$f(x) = \frac{1}{4-x^2} + \log_{10}(x^3 - x) \text{ is (2019 Main, 9 April II)}$$

- (a) $(-1, 0) \cup (1, 2) \cup (3, \infty)$ (b) $(-2, -1) \cup (-1, 0) \cup (2, \infty)$
 (c) $(-1, 0) \cup (1, 2) \cup (2, \infty)$ (d) $(1, 2) \cup (2, \infty)$

3. Let $f(x) = a^x (a > 0)$ be written as $f(x) = f_1(x) + f_2(x)$, where $f_1(x)$ is an even function and $f_2(x)$ is an odd function. Then $f_1(x+y) + f_1(x-y)$ equals

(2019 Main, 8 April II)

- (a) $2f_1(x+y) \cdot f_2(x-y)$ (b) $2f_1(x+y) \cdot f_1(x-y)$
 (c) $2f_1(x) \cdot f_2(y)$ (d) $2f_1(x) \cdot f_1(y)$

4. Domain of definition of the function

$$f(x) = \sqrt{\sin^{-1}(2x) + \frac{\pi}{6}} \text{ for real valued } x, \text{ is (2003, 2M)}$$

- (a) $\left[-\frac{1}{4}, \frac{1}{2}\right]$ (b) $\left[-\frac{1}{2}, \frac{1}{2}\right]$
 (c) $\left(-\frac{1}{2}, \frac{1}{9}\right)$ (d) $\left[-\frac{1}{4}, \frac{1}{4}\right]$

5. Range of the function $f(x) = \frac{x^2 + x + 2}{x^2 + x + 1}; x \in R$ is

(2003, 2M)

- (a) $(1, \infty)$ (b) $(1, 11/7)$
 (c) $(1, 7/3]$ (d) $(1, 7/5)$

6. Let $f(x) = (1 + b^2)x^2 + 2bx + 1$ and let $m(b)$ be the minimum value of $f(x)$. As b varies, the range of $m(b)$ is

(2001, 1M)

- (a) $[0, 1]$ (b) $\left[0, \frac{1}{2}\right]$
 (c) $\left[\frac{1}{2}, 1\right]$ (d) $(0, 1]$

7. The domain of definition of $f(x) = \frac{\log_2(x+3)}{x^2 + 3x + 2}$ is

(2001, 1M)

- (a) $R / \{-1, -2\}$
 (b) $(-2, \infty)$
 (c) $R / \{-1, -2, -3\}$
 (d) $(-3, \infty) / \{-1, -2\}$

8. The domain of definition of the function $y(x)$ is given by the equation $2^x + 2^y = 2$, is

(2000, 1M)

- (a) $0 < x \leq 1$ (b) $0 \leq x \leq 1$
 (c) $-\infty < x \leq 0$ (d) $-\infty < x < 1$

9. Let $f(\theta) = \sin \theta (\sin \theta + \sin 3\theta)$. Then, $f(\theta)$

(2000, 1M)

- (a) ≥ 0 , only when $\theta \geq 0$ (b) ≤ 0 , for all real θ
 (c) ≥ 0 , for all real θ (d) ≤ 0 , only when $\theta \leq 0$

10. The domain of definition of the function

$$y = \frac{1}{\log_{10}(1-x)} + \sqrt{x+2} \text{ is}$$

(1983, 1M)

- (a) $(-3, -2)$ excluding -2.5
 (b) $[0, 1]$ excluding 0.5
 (c) $(-2, 1)$ excluding 0
 (d) None of these

Match the Columns

Match the conditions/expressions in Column I with statement in Column II.

11. Let $f(x) = \frac{x^2 - 6x + 5}{x^2 - 5x + 6}$.

(2007, 6M)

Column I	Column II
A. If $-1 < x < 1$, then $f(x)$ satisfies	p. $0 < f(x) < 1$
B. If $1 < x < 2$, then $f(x)$ satisfies	q. $f(x) < 0$
C. If $3 < x < 5$, then $f(x)$ satisfies	r. $f(x) > 0$
D. If $x > 5$, then $f(x)$ satisfies	s. $f(x) < 1$

172 Functions

Objective Question II

(One or more than one correct option)

12. If S is the set of all real x such that $\frac{2x-1}{2x^3+3x^2+x}$ is positive, then S contains (1986, 2M)
- (a) $\left(-\infty, -\frac{3}{2}\right)$ (b) $\left(-\frac{3}{2}, -\frac{1}{4}\right)$
 (c) $\left(-\frac{1}{4}, \frac{1}{2}\right)$ (d) $\left(\frac{1}{2}, 3\right)$

Fill in the Blanks

13. If $f(x) = \sin \log \left(\frac{\sqrt{4-x^2}}{1-x} \right)$, then the domain of $f(x)$ is (1985, 2M)
14. The domain of the function $f(x) = \sin^{-1} \left(\log_2 \frac{x^2}{2} \right)$ is given by ... (1984, 2M)
15. The values of $f(x) = 3 \sin \left(\sqrt{\frac{\pi^2}{16} - x^2} \right)$ lie in the interval (1983, 2M)

Topic 2 Composite of Functions

Objective Questions I (Only one correct option)

1. For a suitable chosen real constant a , let a function $f: R - \{a\} \rightarrow R$ be defined by $f(x) = \frac{a-x}{a+x}$. Further suppose that for any real number $x \neq -a$ and $f(x) \neq -a$, $(f \circ f)(x) = x$. Then, $f\left(-\frac{1}{2}\right)$ is equal to [2020 Main, 6 Sep III]
- (a) $\frac{1}{3}$ (b) $-\frac{1}{3}$
 (c) -3 (d) 3
2. For $x \in \left(0, \frac{3}{2}\right)$, let $f(x) = \sqrt{x}$, $g(x) = \tan x$ and $h(x) = \frac{1-x^2}{1+x^2}$. If $\phi(x) = ((h \circ f) \circ g)(x)$, then $\phi\left(\frac{\pi}{3}\right)$ is equal to (2019 Main, 12 April I)
- (a) $\tan \frac{\pi}{12}$ (b) $\tan \frac{11\pi}{12}$
 (c) $\tan \frac{7\pi}{12}$ (d) $\tan \frac{5\pi}{12}$
3. Let $f(x) = x^2$, $x \in R$. For any $A \subseteq R$, define $g(A) = \{x \in R: f(x) \in A\}$. If $S = [0, 4]$, then which one of the following statements is not true? (2019 Main, 10 April I)
- (a) $f(g(S)) = S$ (b) $g(f(S)) \neq S$
 (c) $g(f(S)) = g(S)$ (d) $f(g(S)) \neq f(S)$

True/False

16. If $f_1(x)$ and $f_2(x)$ are defined on domains D_1 and D_2 respectively, then $f_1(x) + f_2(x)$ is defined on $D_1 \cap D_2$. (1988, 1M)

Analytical & Descriptive Questions

17. Find the range of values of t for which $2 \sin t = \frac{1-2x+5x^2}{3x^2-2x-1}$, $t \in \left[-\frac{\pi}{2}, \frac{\pi}{2}\right]$. (2005, 2M)
18. Let $y = \sqrt{\frac{(x+1)(x-3)}{(x-2)}}$. Find all the real values of x for which y takes real values. (1980, 2M)

Integer & Numerical Answer Type Question

19. The value of the limit $\lim_{x \rightarrow \frac{\pi}{2}} \frac{4\sqrt{2}(\sin 3x + \sin x)}{\left(2 \sin 2x \sin \frac{3x}{2} + \cos \frac{5x}{2}\right) - \left(\sqrt{2} + \sqrt{2} \cos 2x + \cos \frac{3x}{2}\right)}$ is (2020 Adv.)

4. Let $\sum_{k=1}^{10} f(a+k) = 16(2^{10} - 1)$, where the function f satisfies $f(x+y) = f(x)f(y)$ for all natural numbers x, y and $f(1) = 2$. Then, the natural number 'a' is (2019 Main, 9 April I)
- (a) 2 (b) 4 (c) 3 (d) 16
5. If $f(x) = \log_e \left(\frac{1-x}{1+x} \right)$, $|x| < 1$, then $f\left(\frac{2x}{1+x^2}\right)$ is equal to (2019 Main, 8 April I)
- (a) $2f(x)$ (b) $2f(x^2)$
 (c) $(f(x))^2$ (d) $-2f(x)$
6. For $x \in R - \{0, 1\}$, let $f_1(x) = \frac{1}{x}$, $f_2(x) = 1-x$ and $f_3(x) = \frac{1}{1-x}$ be three given functions. If a function, $J(x)$ satisfies $(f_2 \circ J \circ f_1)(x) = f_3(x)$, then $J(x)$ is equal to (2019 Main, 9 Jan I)
- (a) $f_2(x)$ (b) $f_3(x)$
 (c) $f_1(x)$ (d) $\frac{1}{f_3(x)}$
7. Let $a, b, c \in R$. If $f(x) = ax^2 + bx + c$ be such that $a + b + c = 3$ and $f(x+y) = f(x) + f(y) + xy$, $\forall x, y \in R$, then $\sum_{n=1}^{10} f(n)$ is equal to (2017 Main)
- (a) 330 (b) 165 (c) 190 (d) 255

8. Let $f(x) = x^2$ and $g(x) = \sin x$ for all $x \in R$. Then, the set of all x satisfying $(f \circ g \circ f \circ g)(x) = (g \circ f \circ g \circ f)(x)$, where $(f \circ g)(x) = f(g(x))$, is (2011)
- (a) $\pm \sqrt{n\pi}$, $n \in \{0, 1, 2, \dots\}$
 (b) $\pm \sqrt{n\pi}$, $n \in \{1, 2, \dots\}$
 (c) $\pi/2 + 2n\pi$, $n \in \{\dots, -2, -1, 0, 1, 2, \dots\}$
 (d) $2n\pi$, $n \in \{\dots, -2, -1, 0, 1, 2, \dots\}$

9. Let $f(x) = \frac{\alpha x}{x+1}$, $x \neq -1$. Then, for what value of α is $f[f(x)] = x$? (2001, 1M)
- (a) $\sqrt{2}$ (b) $-\sqrt{2}$ (c) 1 (d) -1

10. Let $g(x) = 1 + x - [x]$ and $f(x) = \begin{cases} -1, & x < 0 \\ 0, & x = 0 \\ 1, & x > 0 \end{cases}$, then for all x , $f[g(x)]$ is equal to (2001, 1M)
- (a) x (b) 1 (c) $f(x)$ (d) $g(x)$

11. If $g\{f(x)\} = |\sin x|$ and $f\{g(x)\} = (\sin \sqrt{x})^2$, then (1998, 2M)
- (a) $f(x) = \sin^2 x$, $g(x) = \sqrt{x}$
 (b) $f(x) = \sin x$, $g(x) = |x|$
 (c) $f(x) = x^2$, $g(x) = \sin \sqrt{x}$
 (d) f and g cannot be determined

12. If $f(x) = \cos(\log x)$, then $f(x) \cdot f(y) - \frac{1}{2} \left[f\left(\frac{x}{y}\right) + f(xy) \right]$ has the value (1983, 1M)
- (a) -1 (b) $\frac{1}{2}$
 (c) -2 (d) None of these

13. Let $f(x) = |x - 1|$. Then, (1983, 1M)
- (a) $f(x^2) = \{f(x)\}^2$ (b) $f(x + y) = f(x) + f(y)$
 (c) $f(|x|) = |f(x)|$ (d) None of the above

Objective Questions II

(One or more than one correct option)

14. Let $f(x) = \sin \left[\frac{\pi}{6} \sin \left(\frac{\pi}{2} \sin x \right) \right]$ for all $x \in R$ and $g(x) = \frac{\pi}{2} \sin x$ for all $x \in R$. Let $(f \circ g)(x)$ denotes $f\{g(x)\}$ and $(g \circ f)(x)$ denotes $g\{f(x)\}$. Then, which of the following is/are true? (2015 Adv.)
- (a) Range of f is $\left[-\frac{1}{2}, \frac{1}{2}\right]$ (b) Range of $f \circ g$ is $\left[-\frac{1}{2}, \frac{1}{2}\right]$
 (c) $\lim_{x \rightarrow 0} \frac{f(x)}{g(x)} = \frac{\pi}{6}$
 (d) There is an $x \in R$ such that $(g \circ f)(x) = 1$

15. If $f(x) = \cos [\pi^2] x + \cos [-\pi^2] x$, where $[x]$ stands for the greatest integer function, then (1991, 2M)
- (a) $f(\pi/2) = -1$
 (b) $f(\pi) = 1$
 (c) $f(-\pi) = 0$
 (d) $f(\pi/4) = 1$

16. Let $g(x)$ be a function defined on $[-1, 1]$. If the area of the equilateral triangle with two of its vertices at $(0, 0)$ and $[x, g(x)]$ is $\sqrt{3}/4$, then the function $g(x)$ is (1989, 2M)
- (a) $g(x) = \pm \sqrt{1-x^2}$ (b) $g(x) = \sqrt{1-x^2}$
 (c) $g(x) = -\sqrt{1-x^2}$ (d) $g(x) = \sqrt{1+x^2}$

17. If $y = f(x) = \frac{x+2}{x-1}$, then (1984, 3M)
- (a) $x = f(y)$ (b) $f(1) = 3$
 (c) y increases with x for $x < 1$
 (d) f is a rational function of x

Fill in the Blank

18. If $f(x) = \sin^2 x + \sin^2 \left(x + \frac{\pi}{3}\right) + \cos x \cos \left(x + \frac{\pi}{3}\right)$ and $g\left(\frac{5}{4}\right) = 1$, then $(g \circ f)(x) = \dots$ (1996, 2M)

True/False

19. If $f(x) = (a - x^n)^{1/n}$, where $a > 0$ and n is a positive integer, then $f[f(x)] = x$. (1983, 1M)

Analytical & Descriptive Question

20. Find the natural number a for which $\sum_{k=1}^n f(a+k) = 16(2^n - 1)$, where the function f satisfies the relation $f(x+y) = f(x)f(y)$ for all natural numbers x, y and further $f(1) = 2$. (1992, 6M)

Integer & Numerical Answer Type Question

21. Let the function $f : [0, 1] \rightarrow R$ be defined by $f(x) = \frac{4^x}{4^x + 2}$. Then the value of $f\left(\frac{1}{40}\right) + f\left(\frac{2}{40}\right) + f\left(\frac{3}{40}\right) + \dots + f\left(\frac{39}{40}\right) - f\left(\frac{1}{2}\right)$ is (2020 Adv.)

Topic 3 Types of Functions

Objective Questions I (Only one correct option)

1. If the function $f: \mathbf{R} \rightarrow \mathbf{R}$ is defined by $f(x) = |x|(x - \sin x)$, then which of the following statements is TRUE?

(a) f is one-one, but NOT onto (2020 Adv.)
 (b) f is onto, but NOT one-one
 (c) f is BOTH one-one and onto
 (d) f is NEITHER one-one NOR onto

2. If the function $f: \mathbf{R} - \{1, -1\} \rightarrow A$ defined by

$$f(x) = \frac{x^2}{1-x^2}, \text{ is surjective, then } A \text{ is equal to} \quad (2019 \text{ Main, 9 April I})$$

(a) $\mathbf{R} - \{-1\}$
 (b) $[0, \infty)$
 (c) $\mathbf{R} - [-1, 0)$
 (d) $\mathbf{R} - (-1, 0)$

3. Let a function $f: (0, \infty) \rightarrow (0, \infty)$ be defined by

$$f(x) = \left| 1 - \frac{1}{x} \right|. \text{ Then, } f \text{ is} \quad (2019 \text{ Main, 11 Jan II})$$

(a) injective only
 (b) both injective as well as surjective
 (c) not injective but it is surjective
 (d) neither injective nor surjective

4. The number of functions f from $\{1, 2, 3, \dots, 20\}$ onto $\{1, 2, 3, \dots, 20\}$ such that $f(k)$ is a multiple of 3, whenever k is a multiple of 4, is (2019 Main, 11 Jan II)

(a) $(15)! \times 6!$ (b) $5^6 \times 15$
 (c) $5! \times 6!$ (d) $6^5 \times (15)!$

5. Let $f: \mathbf{R} \rightarrow \mathbf{R}$ be defined by $f(x) = \frac{x}{1+x^2}$,

$x \in \mathbf{R}$. Then, the range of f is (2019 Main, 11 Jan I)

(a) $\left[-\frac{1}{2}, \frac{1}{2}\right]$ (b) $(-1, 1) - \{0\}$
 (c) $\mathbf{R} - \left[-\frac{1}{2}, \frac{1}{2}\right]$ (d) $\mathbf{R} - [-1, 1]$

6. Let N be the set of natural numbers and two functions f and g be defined as $f, g: N \rightarrow N$ such that

$$f(n) = \begin{cases} \frac{n+1}{2}; & \text{if } n \text{ is odd} \\ \frac{n}{2}; & \text{if } n \text{ is even} \end{cases}$$

and $g(n) = n - (-1)^n$. Then, $f \circ g$ is (2019 Main, 10 Jan II)

(a) one-one but not onto (b) onto but not one-one
 (c) both one-one and onto (d) neither one-one nor onto

7. Let $A = \{x \in \mathbf{R} : x \text{ is not a positive integer}\}$. Define a function $f: A \rightarrow \mathbf{R}$ as $f(x) = \frac{2x}{x-1}$, then f is (2019 Main, 9 Jan II)

(a) injective but not surjective
 (b) not injective
 (c) surjective but not injective
 (d) neither injective nor surjective

8. The function $f: \mathbf{R} \rightarrow \left[-\frac{1}{2}, \frac{1}{2}\right]$ defined as $f(x) = \frac{x}{1+x^2}$ is (2017 Main)

(a) invertible
 (b) injective but not surjective
 (c) surjective but not injective
 (d) neither injective nor surjective

9. The function $f: [0, 3] \rightarrow [1, 29]$, defined by

$$f(x) = 2x^3 - 15x^2 + 36x + 1, \text{ is} \quad (2012)$$

(a) one-one and onto (b) onto but not one-one
 (c) one-one but not onto (d) neither one-one nor onto

10. $f(x) = \begin{cases} x, & \text{if } x \text{ is rational} \\ 0, & \text{if } x \text{ is irrational} \end{cases}$ $g(x) = \begin{cases} 0, & \text{if } x \text{ is rational} \\ x, & \text{if } x \text{ is irrational} \end{cases}$

Then, $f - g$ is (2005, 1M)

(a) one-one and into (b) neither one-one nor onto
 (c) many one and onto (d) one-one and onto

11. If $f: [0, \infty) \rightarrow [0, \infty)$ and $f(x) = \frac{x}{1+x}$, then f is (2003, 2M)

(a) one-one and onto (b) one-one but not onto
 (c) onto but not one-one (d) neither one-one nor onto

12. Let function $f: \mathbf{R} \rightarrow \mathbf{R}$ be defined by $f(x) = 2x + \sin x$ for $x \in \mathbf{R}$. Then, f is (2002, 1M)

(a) one-to-one and onto (b) one-to-one but not onto
 (c) onto but not one-to-one (d) neither one-to-one nor onto

13. Let $E = \{1, 2, 3, 4\}$ and $F = \{1, 2\}$. Then, the number of onto functions from E to F is (2001, 1M)

(a) 14 (b) 16 (c) 12 (d) 8

Match the Columns

Match the conditions/expressions in Column I with statement in Column II.

14. Let $f_1: \mathbf{R} \rightarrow \mathbf{R}$, $f_2: [0, \infty) \rightarrow \mathbf{R}$, $f_3: \mathbf{R} \rightarrow \mathbf{R}$ and $f_4: \mathbf{R} \rightarrow [0, \infty)$ be defined by (2014 Adv.)

$$f_1(x) = \begin{cases} |x|, & \text{if } x < 0 \\ e^x, & \text{if } x \geq 0 \end{cases}; f_2(x) = x^2; f_3(x) = \begin{cases} \sin x, & \text{if } x < 0 \\ x, & \text{if } x \geq 0 \end{cases}$$

$$\text{and } f_4(x) = \begin{cases} f_2[f_1(x)], & \text{if } x < 0 \\ f_2[f_1(x)] - 1, & \text{if } x \geq 0 \end{cases}$$

Column I	Column II
A. f_4 is	p. onto but not one-one
B. f_3 is	q. neither continuous nor one-one
C. $f_2 \circ f_1$ is	r. differentiable but not one-one
D. f_2 is	s. continuous and one-one

Codes

A B C D A B C D
 (a) r p s q (b) p r s q
 (c) r p q s (d) p r q s

15. Let the functions defined in Column I have domain $(-\pi/2, \pi/2)$ and range $(-\infty, \infty)$ (1992, 2M)

Column I	Column II
A. $1 + 2x$	p. onto but not one-one
B. $\tan x$	q. one-one but not onto
	r. one-one and onto
	s. neither one-one nor onto

Objective Question II

(One or more than one correct option)

16. Let $f: \left(-\frac{\pi}{2}, \frac{\pi}{2}\right) \rightarrow R$ be given by $f(x) = [\log(\sec x + \tan x)]^3$. Then,
 (a) $f(x)$ is an odd function (b) $f(x)$ is a one-one function
 (c) $f(x)$ is an onto function (d) $f(x)$ is an even function

Fill in the Blanks

17. There are exactly two distinct linear functions, ..., and... which map $\{-1, 1\}$ onto $\{0, 2\}$. (1989, 2M)

Topic 4 Inverse and Periodic Functions

Objective Questions I (Only one correct option)

1. The inverse function of

$$f(x) = \frac{8^{2x} - 8^{-2x}}{8^{2x} + 8^{-2x}}, x \in (-1, 1)$$

[2020 Main 8 Jan II]

- (a) $\frac{1}{4}(\log_8 e) \log_e \left(\frac{1-x}{1+x}\right)$
 (b) $\frac{1}{4} \log_e \left(\frac{1-x}{1+x}\right)$
 (c) $\frac{1}{4}(\log_8 e) \log_e \left(\frac{1+x}{1-x}\right)$ (d) $\frac{1}{4} \log_e \left(\frac{1+x}{1-x}\right)$
2. If X and Y are two non-empty sets where $f: X \rightarrow Y$, is function is defined such that
 $f(C) = \{f(x) : x \in C\}$ for $C \subseteq X$
 and $f^{-1}(D) = \{x : f(x) \in D\}$ for $D \subseteq Y$,
 for any $A \subseteq Y$ and $B \subseteq Y$, then (2005, 1M)
 (a) $f^{-1}\{f(A)\} = A$
 (b) $f^{-1}\{f(A)\} = A$, only if $f(X) = Y$
 (c) $f\{f^{-1}(B)\} = B$, only if $B \subseteq f(X)$
 (d) $f\{f^{-1}(B)\} = B$
3. If $f(x) = \sin x + \cos x$, $g(x) = x^2 - 1$, then $g\{f(x)\}$ is invertible in the domain (2004, 1M)

- (a) $\left[0, \frac{\pi}{2}\right]$ (b) $\left[-\frac{\pi}{4}, \frac{\pi}{4}\right]$
 (c) $\left[-\frac{\pi}{2}, \frac{\pi}{2}\right]$ (d) $[0, \pi]$

True/False

18. The function $f(x) = \frac{x^2 + 4x + 30}{x^2 - 8x + 18}$ is not one-to-one. (1983, 1M)

Analytical & Descriptive Question

19. A function $f: IR \rightarrow IR$, where IR , is the set of real numbers, is defined by $f(x) = \frac{\alpha x^2 + 6x - 8}{\alpha + 6x - 8x^2}$.
 Find the interval of values of α for which is onto. Is the functions one-to-one for $\alpha = 3$? Justify your answer. (1996, 5M)
20. Let A and B be two sets each with a finite number of elements. Assume that there is an injective mapping from A to B and that there is an injective mapping from B to A . Prove that there is a bijective mapping from A to B . (1981, 2M)

4. Suppose $f(x) = (x+1)^2$ for $x \geq -1$. If $g(x)$ is the function whose graph is reflection of the graph of $f(x)$ with respect to the line $y = x$, then $g(x)$ equals (2002, 1M)

- (a) $-\sqrt{x} - 1, x \geq 0$ (b) $\frac{1}{(x+1)^2}, x > -1$
 (c) $\sqrt{x+1}, x \geq -1$ (d) $\sqrt{x} - 1, x \geq 0$

5. If $f: [1, \infty) \rightarrow [2, \infty)$ is given by $f(x) = x + \frac{1}{x}$, then $f^{-1}(x)$ equals (2001, 1M)

- (a) $\frac{x + \sqrt{x^2 - 4}}{2}$ (b) $\frac{x}{1 + x^2}$
 (c) $\frac{x - \sqrt{x^2 - 4}}{2}$ (d) $1 + \sqrt{x^2 - 4}$

6. If the function $f: [1, \infty) \rightarrow [1, \infty)$ is defined by $f(x) = 2^{x(x-1)}$, then $f^{-1}(x)$ is (1999, 2M)

- (a) $\left(\frac{1}{2}\right)^{x(x-1)}$ (b) $\frac{1}{2}(1 + \sqrt{1 + 4 \log_2 x})$
 (c) $\frac{1}{2}(1 - \sqrt{1 + 4 \log_2 x})$ (d) not defined

7. If $f(x) = 3x - 5$, then $f^{-1}(x)$ (1998, 2M)

- (a) is given by $\frac{1}{3x-5}$
 (b) is given by $\frac{x+5}{3}$
 (c) does not exist because f is not one-one
 (d) does not exist because f is not onto

176 Functions

8. Which of the following functions is periodic? (1983, 1M)

- (a) $f(x) = x - [x]$, where $[x]$ denotes the greatest integer less than or equal to the real number x
 (b) $f(x) = \sin(1/x)$ for $x \neq 0$, $f(0) = 0$
 (c) $f(x) = x \cos x$
 (d) None of the above

Objective Question II

(One or more than one correct option)

9. Let $f: (0, 1) \rightarrow R$ be defined by $f(x) = \frac{b-x}{1-bx}$, where b is a constant such that $0 < b < 1$. Then, (2011)

- (a) f is not invertible on $(0, 1)$
 (b) $f \neq f^{-1}$ on $(0, 1)$ and $f'(b) = \frac{1}{f'(0)}$
 (c) $f = f^{-1}$ on $(0, 1)$ and $f'(b) = \frac{1}{f'(0)}$
 (d) f^{-1} is differentiable on $(0, 1)$

Assertion and Reason

For the following questions, choose the correct answer from the codes (a), (b), (c) and (d) defined as follows.

- (a) Statement I is true, Statement II is also true;
 Statement II is the correct explanation of Statement I.

(b) Statement I is true, Statement II is also true;
 Statement II is not the correct explanation of Statement I.

(c) Statement I is true; Statement II is false.

(d) Statement I is false; Statement II is true.

10. Let $F(x)$ be an indefinite integral of $\sin^2 x$.

Statement I The function $F(x)$ satisfies $F(x + \pi) = F(x)$ for all real x .
 Because

Statement II $\sin^2(x + \pi) = \sin^2 x$, for all real x . (2007, 3M)

Analytical & Descriptive Question

11. Let f be a one-one function with domain $\{x, y, z\}$ and range $\{1, 2, 3\}$. It is given that exactly one of the following statements is true and the remaining two are false $f(x) = 1$, $f(y) \neq 1$, $f(z) \neq 2$ determine $f^{-1}(1)$. (1982, 2M)

12. If f is an even function defined on the interval $(-5, 5)$, then four real values of x satisfying the equation

$f(x) = f\left(\frac{x+1}{x+2}\right)$ are (1996, 1M)

Answers

Topic 1

1. (a) 2. (c) 3. (d) 4. (a)
 5. (c) 6. (d) 7. (d) 8. (d)
 9. (c) 10. (c) 11. $A \rightarrow p; B \rightarrow q; C \rightarrow q; D \rightarrow p$
 12. (a,d) 13. $(-2,1)$ 14. Domain $\in [-2,-1] \cup [1,2]$
 15. $\left[0, \frac{3}{\sqrt{2}}\right]$ 16. True 17. $t \in \left[-\frac{\pi}{2}, \frac{\pi}{10}\right] \cup \left[\frac{3\pi}{10}, \frac{\pi}{2}\right]$
 18. $x \in [-1, 2) \cup [3, \infty)$ 19. (8)

Topic 2

1. (d) 2. (b) 3. (c) 4. (c)
 5. (a) 6. (b) 7. (a) 8. (b)
 9. (d) 10. (b) 11. (a) 12. (d)
 13. (d) 14. (a,b,c) 15. (a, c) 16. (b, c)
 17. (a, d) 18. 1 19. True 20. $(a=3)$
 21. (19)

Topic 3

1. (c) 2. (c) 3. (d) 4. (a)
 5. (a) 6. (b) 7. (a) 8. (c)
 9. (b) 10. (d) 11. (b) 12. (a)
 13. (a) 14. (d) 15. $A \rightarrow q; B \rightarrow r$
 16. (a, b, c)
 17. $y = x + 1$ and $y = -x + 1$
 18. True
 19. $2 \leq \alpha \leq 14$, No

Topic 4

1. (c) 2. (c) 3. (b) 4. (d)
 5. (a) 6. (b) 7. (b) 8. (a)
 9. (b) 10. (d)
 11. $f^{-1}(1) = y$ 12. $\left(\frac{\pm 3 \pm \sqrt{5}}{2}\right)$

Hints & Solutions

Topic 1 Classification of Functions, Domain and Range

1. Given relation

$$R = \{(x, y) : x, y \in \mathbb{Z}, x^2 + 3y^2 \leq 8\}$$

For, $y^2 = 0, x^2 = 0, 1, 4$

For, $y^2 = 1, x^2 = 0, 1, 4$

For, $y^2 = 4, x^2 \in \emptyset$

\therefore Range of R is possible values of $y = \{-1, 0, 1\}$

\therefore Domain of $R^{-1} = \text{Range of } R = \{-1, 0, 1\}$

2. Given function $f(x) = \frac{1}{4-x^2} + \log_{10}(x^3 - x)$

For domain of $f(x)$

$$4 - x^2 \neq 0 \Rightarrow x \neq \pm 2 \quad \dots(i)$$

and $x^3 - x > 0$

$$\Rightarrow x(x-1)(x+1) > 0$$

From Wavy curve method,

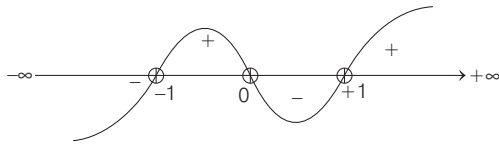

$$x \in (-1, 0) \cup (1, \infty) \quad \dots(ii)$$

From Eqs. (i) and (ii), we get the domain of $f(x)$ as $(-1, 0) \cup (1, 2) \cup (2, \infty)$.

3. Given, function $f(x) = a^x, a > 0$ is written as sum of an even and odd functions $f_1(x)$ and $f_2(x)$ respectively.

Clearly, $f_1(x) = \frac{a^x + a^{-x}}{2}$ and $f_2(x) = \frac{a^x - a^{-x}}{2}$

So, $f_1(x+y) + f_1(x-y)$

$$= \frac{1}{2} [a^{x+y} + a^{-(x+y)}] + \frac{1}{2} [a^{x-y} + a^{-(x-y)}]$$

$$= \frac{1}{2} \left[a^x a^y + \frac{1}{a^x a^y} + \frac{a^x}{a^y} + \frac{a^y}{a^x} \right]$$

$$= \frac{1}{2} \left[a^x \left(a^y + \frac{1}{a^y} \right) + \frac{1}{a^x} \left(\frac{1}{a^y} + a^y \right) \right]$$

$$= \frac{1}{2} \left(a^x + \frac{1}{a^x} \right) \left(a^y + \frac{1}{a^y} \right)$$

$$= 2 \left(\frac{a^x + a^{-x}}{2} \right) \left(\frac{a^y + a^{-y}}{2} \right) = 2f_1(x) \cdot f_1(y)$$

4. Here, $f(x) = \sqrt{\sin^{-1}(2x) + \frac{\pi}{6}}$, to find domain we must have,

$$\sin^{-1}(2x) + \frac{\pi}{6} \geq 0 \quad \left[\text{but } -\frac{\pi}{2} \leq \sin^{-1} \theta \leq \frac{\pi}{2} \right]$$

$$-\frac{\pi}{6} \leq \sin^{-1}(2x) \leq \frac{\pi}{2}$$

$$\sin\left(\frac{-\pi}{6}\right) \leq 2x \leq \sin\frac{\pi}{2} \Rightarrow \frac{-1}{2} \leq 2x \leq \frac{1}{2}$$

$$\frac{-1}{4} \leq x \leq \frac{1}{2}$$

$$\therefore x \in \left[\frac{-1}{4}, \frac{1}{2} \right]$$

5. Let $y = f(x) = \frac{x^2 + x + 2}{x^2 + x + 1}, x \in \mathbb{R}$

$$\therefore y = \frac{x^2 + x + 2}{x^2 + x + 1}$$

$$y = 1 + \frac{1}{x^2 + x + 1} \quad [\text{i.e. } y > 1] \quad \dots(i)$$

$$\Rightarrow yx^2 + yx + y = x^2 + x + 2$$

$$\Rightarrow x^2(y-1) + x(y-1) + (y-2) = 0, \forall x \in \mathbb{R}$$

Since, x is real, $D \geq 0$

$$\Rightarrow (y-1)^2 - 4(y-1)(y-2) \geq 0$$

$$\Rightarrow (y-1)\{(y-1) - 4(y-2)\} \geq 0$$

$$\Rightarrow (y-1)(-3y+7) \geq 0$$

$$\Rightarrow 1 \leq y \leq \frac{7}{3} \quad \dots(ii)$$

From Eqs. (i) and (ii), Range $\in \left[1, \frac{7}{3} \right]$

6. Given, $f(x) = (1+b^2)x^2 + 2bx + 1$

$$= (1+b^2) \left(x + \frac{b}{1+b^2} \right)^2 + 1 - \frac{b^2}{1+b^2}$$

$m(b) = \text{minimum value of } f(x) = \frac{1}{1+b^2}$ is positive

and $m(b)$ varies from 1 to 0, so range = $(0, 1]$

7. Given, $f(x) = \frac{\log_2(x+3)}{(x^2+3x+2)} = \frac{\log_2(x+3)}{(x+1)(x+2)}$

For numerator, $x+3 > 0$

$$\Rightarrow x > -3 \quad \dots(i)$$

and for denominator, $(x+1)(x+2) \neq 0$

$$\Rightarrow x \neq -1, -2 \quad \dots(ii)$$

From Eqs. (i) and (ii),

Domain is $(-3, \infty) / \{-1, -2\}$

8. Given, $2^x + 2^y = 2, \forall x, y \in \mathbb{R}$

But $2^x, 2^y > 0, \forall x, y \in \mathbb{R}$

Therefore, $2^x = 2 - 2^y < 2 \Rightarrow 0 < 2^x < 2$

Taking log on both sides with base 2, we get

$$\log_2 0 < \log_2 2^x < \log_2 2 \Rightarrow -\infty < x < 1$$

9. It is given,

$$f(\theta) = \sin \theta (\sin \theta + \sin 3\theta)$$

$$= (\sin \theta + 3 \sin \theta - 4 \sin^3 \theta) \sin \theta$$

178 Functions

$$\begin{aligned}
 &= (4 \sin \theta - 4 \sin^3 \theta) \sin \theta = \sin^2 \theta (4 - 4 \sin^2 \theta) \\
 &= 4 \sin^2 \theta \cos^2 \theta = (2 \sin \theta \cos \theta)^2 \\
 &= (\sin 2\theta)^2 \geq 0
 \end{aligned}$$

which is true for all θ .

10. For domain of y ,

$$\begin{aligned}
 &1 - x > 0, 1 - x \neq 1 \quad \text{and} \quad x + 2 > 0 \\
 \Rightarrow &x < 1, x \neq 0 \quad \text{and} \quad x > -2 \\
 \Rightarrow &-2 < x < 1 \text{ excluding } 0 \\
 \Rightarrow &x \in (-2, 1) - \{0\}
 \end{aligned}$$

11. Given, $f(x) = \frac{(x-1)(x-5)}{(x-2)(x-3)}$

The graph of $f(x)$ is shown as :

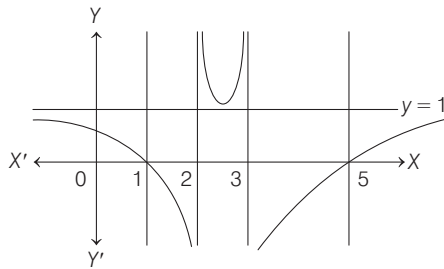

- A. If $-1 < x < 1 \Rightarrow 0 < f(x) < 1$
- B. If $1 < x < 2 \Rightarrow f(x) < 0$
- C. If $3 < x < 5 \Rightarrow f(x) < 0$
- D. If $x > 5 \Rightarrow 0 < f(x) < 1$

12. Since, $\frac{2x-1}{2x^3+3x^2+x} > 0$

$$\begin{aligned}
 \Rightarrow &\frac{(2x-1)}{x(2x^2+3x+1)} > 0 \\
 \Rightarrow &\frac{(2x-1)}{x(2x+1)(x+1)} > 0
 \end{aligned}$$

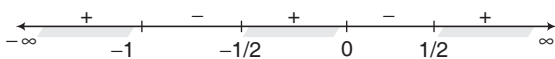

Hence, the solution set is,

$$x \in (-\infty, -1) \cup (-1/2, 0) \cup (1/2, \infty)$$

Hence, (a) and (d) are the correct options.

13. Given, $f(x) = \sin \log \left(\frac{\sqrt{4-x^2}}{1-x} \right)$

For domain, $\frac{\sqrt{4-x^2}}{1-x} > 0$, $4-x^2 > 0$ and $1-x \neq 0$

$$\begin{aligned}
 \Rightarrow &(1-x) > 0 \quad \text{and} \quad 4-x^2 > 0 \\
 \Rightarrow &x < 1 \quad \text{and} \quad |x| < 2 \Rightarrow -2 < x < 1
 \end{aligned}$$

Thus, domain $\in (-2, 1)$.

14. Given, $f(x) = \sin^{-1} \left(\log_2 \frac{x^2}{2} \right)$

For domain, $-1 \leq \log_2 \frac{x^2}{2} \leq 1$

$$\Rightarrow \frac{1}{2} \leq \frac{x^2}{2} \leq 2$$

$$\Rightarrow 1 \leq x^2 \leq 4$$

$$\Rightarrow 1 \leq |x| \leq 2$$

$$\Rightarrow \text{Domain} \in [-2, -1] \cup [1, 2]$$

15. Given, $f(x) = 3 \sin \sqrt{\frac{\pi^2}{16} - x^2}$

$$\Rightarrow \text{Domain} \in \left[-\frac{\pi}{4}, \frac{\pi}{4} \right]$$

$$\therefore \text{For range, } f'(x) = 3 \cos \left(\sqrt{\frac{\pi^2}{16} - x^2} \right) \cdot \frac{1(-2x)}{2\sqrt{\frac{\pi^2}{16} - x^2}} = 0$$

Where, $\cos \left(\sqrt{\frac{\pi^2}{16} - x^2} \right) = 0$ or $x = 0$

$$\left[\begin{aligned}
 &\text{neglecting } \cos \left(\sqrt{\frac{\pi^2}{16} - x^2} \right) = 0 \Rightarrow \frac{\pi^2}{16} - x^2 = \frac{\pi^2}{4} \\
 &\Rightarrow x^2 = -\frac{3\pi^2}{16}, \text{ never possible}
 \end{aligned} \right]$$

$$\Rightarrow x = 0$$

Thus, $f(0) = 3 \sin \frac{\pi}{4} = \frac{3}{\sqrt{2}}$

and $f\left(-\frac{\pi}{4}\right) = f\left(\frac{\pi}{4}\right) = 0$

Hence, range $\in \left[0, \frac{3}{\sqrt{2}} \right]$

16. Since, domains of $f_1(x)$ and $f_2(x)$ are D_1 and D_2 .

Thus, domain of $[f_1(x) + f_2(x)]$ is $D_1 \cap D_2$.

Hence, given statement is true.

17. Given, $2 \sin t = \frac{1-2x+5x^2}{3x^2-2x-1}$, $t \in \left[-\frac{\pi}{2}, \frac{\pi}{2} \right]$

Put $2 \sin t = y \Rightarrow -2 \leq y \leq 2$

$$\therefore y = \frac{1-2x+5x^2}{3x^2-2x-1}$$

$$\Rightarrow (3y-5)x^2 - 2x(y-1) - (y+1) = 0$$

Since, $x \in R - \{1, -1/3\}$

$$[\text{as, } 3x^2 - 2x - 1 \neq 0 \Rightarrow (x-1)(x+1/3) \neq 0]$$

$$\therefore D \geq 0$$

$$\Rightarrow 4(y-1)^2 + 4(3y-5)(y+1) \geq 0$$

$$\Rightarrow y^2 - y - 1 \geq 0$$

$$\Rightarrow \left(y - \frac{1}{2} \right)^2 - \frac{5}{4} \geq 0$$

$$\Rightarrow \left(y - \frac{1}{2} - \frac{\sqrt{5}}{2} \right) \left(y - \frac{1}{2} + \frac{\sqrt{5}}{2} \right) \geq 0$$

$$\Rightarrow y \leq \frac{1-\sqrt{5}}{2}$$

$$\begin{aligned} \text{or } & y \geq \frac{1 + \sqrt{5}}{2} \\ \Rightarrow & 2 \sin t \leq \frac{1 - \sqrt{5}}{2} \\ \text{or } & 2 \sin t \geq \frac{1 + \sqrt{5}}{2} \\ \Rightarrow & \sin t \leq \sin\left(-\frac{\pi}{10}\right) \\ \text{or } & \sin t \geq \sin\left(\frac{3\pi}{10}\right) \\ \Rightarrow & t \leq -\frac{\pi}{10} \quad \text{or} \quad t \geq \frac{3\pi}{10} \end{aligned}$$

Hence, range of t is $\left[-\frac{\pi}{2}, -\frac{\pi}{10}\right] \cup \left[\frac{3\pi}{10}, \frac{\pi}{2}\right]$.

18. Since, $y = \sqrt{\frac{(x+1)(x-3)}{(x-2)}}$ takes all real values only

when $\frac{(x+1)(x-3)}{(x-2)} \geq 0$

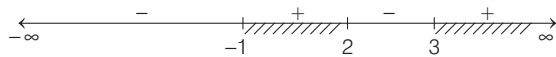

$$\Rightarrow -1 \leq x < 2 \quad \text{or} \quad x \geq 3$$

$$\therefore x \in [-1, 2) \cup [3, \infty).$$

19. The limit

$$\begin{aligned} & \lim_{x \rightarrow \frac{\pi}{2}} \frac{4\sqrt{2}(\sin 3x + \sin x)}{\left(2 \sin 2x \sin \frac{3x}{2} + \cos \frac{5x}{2}\right) - \left(\sqrt{2} + \sqrt{2} \cos 2x + \cos \frac{3x}{2}\right)} \\ &= \lim_{x \rightarrow \frac{\pi}{2}} \frac{4\sqrt{2}(2 \sin 2x \cos x)}{2 \sin 2x \sin \frac{3x}{2} + \left(\cos \frac{5x}{2} - \cos \frac{3x}{2}\right) - \sqrt{2}(1 + \cos 2x)} \\ &= \lim_{x \rightarrow \frac{\pi}{2}} \frac{8\sqrt{2} \sin 2x \cos x}{2 \sin 2x \sin \frac{3x}{2} - 2 \sin 2x \sin \frac{x}{2} - \sqrt{2}(2 \cos^2 x)} \\ &= \lim_{x \rightarrow \frac{\pi}{2}} \frac{4\sqrt{2} \sin 2x \cos x}{\sin 2x \left(\sin \frac{3x}{2} - \sin \frac{x}{2}\right) - \sqrt{2} \cos^2 x} \\ &= \lim_{x \rightarrow \frac{\pi}{2}} \frac{4\sqrt{2} \sin 2x \cos x}{2 \sin 2x \cos x \sin \frac{x}{2} - \sqrt{2} \cos^2 x} \\ &= \lim_{x \rightarrow \frac{\pi}{2}} \frac{4\sqrt{2} \sin 2x}{2 \sin 2x \sin \frac{x}{2} - \sqrt{2} \cos x} \\ &= \lim_{x \rightarrow \frac{\pi}{2}} \frac{8\sqrt{2} \sin x}{4 \sin x \sin \frac{x}{2} - \sqrt{2}} \\ &= \frac{8\sqrt{2}}{\frac{4}{\sqrt{2}} - \sqrt{2}} = \frac{16}{4-2} = 8. \end{aligned}$$

Topic 2 Composite of Functions and Even, Odd Functions

1. For a given function $f : R - \{-a\} \rightarrow R$ defined by

$$f(x) = \frac{a-x}{a+x} \quad \therefore (f \circ f)(x) = x$$

$$\Rightarrow f\left(\frac{a-x}{a+x}\right) = x \Rightarrow \frac{a - \frac{a-x}{a+x}}{a + \frac{a-x}{a+x}} = x$$

$$\Rightarrow \frac{a^2 + ax - a + x}{a^2 + ax + a - x} = x$$

$$\Rightarrow a^2 + ax - a + x = a^2x + ax^2 + ax - x^2$$

$$\Rightarrow a(a-1) = (a^2-1)x + x^2(a-1)$$

$$\Rightarrow (a-1)[x^2 + (a+1)x - a] = 0 \Rightarrow a = 1$$

$$\text{So, } f(x) = \frac{1-x}{1+x} \quad \therefore f\left(-\frac{1}{2}\right) = \frac{1+(1/2)}{1-(1/2)} = 3$$

2. Given, for $x \in (0, 3/2)$, functions

$$f(x) = \sqrt{x} \quad \dots \text{ (i)}$$

$$g(x) = \tan x \quad \dots \text{ (ii)}$$

and $h(x) = \frac{1-x^2}{1+x^2} \quad \dots \text{ (iii)}$

Also given, $\phi(x) = (h \circ f \circ g)(x) = (h \circ f)(g(x))$

$$= h(f(g(x))) = h(f(\tan x))$$

$$= h(\sqrt{\tan x}) = \frac{1 - (\sqrt{\tan x})^2}{1 + (\sqrt{\tan x})^2}$$

$$= \frac{1 - \tan x}{1 + \tan x} = \tan\left(\frac{\pi}{4} - x\right)$$

$$\text{Now, } \phi\left(\frac{\pi}{3}\right) = \tan\left(\frac{\pi}{4} - \frac{\pi}{3}\right)$$

$$= \tan\left(\frac{3\pi - 4\pi}{12}\right) = \tan\left(-\frac{\pi}{12}\right)$$

$$= -\tan\left(\frac{\pi}{12}\right) = \tan\left(\pi - \frac{\pi}{12}\right) = \tan\left(\frac{11\pi}{12}\right)$$

3. Given, functions $f(x) = x^2, x \in R$

and $g(A) = \{x \in R : f(x) \in A\}; A \subseteq R$

Now, for $S = [0, 4]$

$$g(S) = \{x \in R : f(x) \in S = [0, 4]\}$$

$$= \{x \in R : x^2 \in [0, 4]\}$$

$$= \{x \in R : x \in [-2, 2]\}$$

$$\Rightarrow g(S) = [-2, 2]$$

So, $f(g(S)) = [0, 4] = S$

Now, $f(S) = \{x^2 : x \in S = [0, 4]\} = [0, 16]$

and $g(f(S)) = \{x \in R : f(x) \in f(S) = [0, 16]\}$

$$= \{x \in R : f(x) \in [0, 16]\}$$

$$= \{x \in R : x^2 \in [0, 16]\}$$

$$= \{x \in R : x \in [-4, 4]\} = [-4, 4]$$

From above, it is clear that $g(f(S)) = g(S)$.

180 Functions

4. Given, $f(x+y) = f(x) \cdot f(y)$

Let $f(x) = \lambda^x$ [where $\lambda > 0$]

$\therefore f(1) = 2$ (given)

$\therefore \lambda = 2$

$$\begin{aligned} \text{So, } \sum_{k=1}^{10} f(a+k) &= \sum_{k=1}^{10} \lambda^{a+k} = \lambda^a \left(\sum_{k=1}^{10} \lambda^k \right) \\ &= 2^a [2^1 + 2^2 + 2^3 + \dots + 2^{10}] \\ &= 2^a \left[\frac{2(2^{10} - 1)}{2 - 1} \right] \end{aligned}$$

[by using formula of sum of n -terms of a GP having first term ' a ' and common ratio ' r ', is

$$S_n = \frac{a(r^n - 1)}{r - 1}, \text{ where } r > 1]$$

$$\Rightarrow 2^{a+1} (2^{10} - 1) = 16 (2^{10} - 1) \text{ (given)}$$

$$\Rightarrow 2^{a+1} = 16 = 2^4 \Rightarrow a + 1 = 4 \Rightarrow a = 3$$

5. Given, $f(x) = \log_e \left(\frac{1-x}{1+x} \right)$, $|x| < 1$, then

$$\begin{aligned} f\left(\frac{2x}{1+x^2}\right) &= \log_e \left(\frac{1 - \frac{2x}{1+x^2}}{1 + \frac{2x}{1+x^2}} \right) \quad \left[\because \left| \frac{2x}{1+x^2} \right| < 1 \right] \\ &= \log_e \left(\frac{1+x^2-2x}{1+x^2+2x} \right) = \log_e \left(\frac{(1-x)^2}{(1+x)^2} \right) = \log_e \left(\frac{1-x}{1+x} \right)^2 \\ &= 2 \log_e \left(\frac{1-x}{1+x} \right) \quad [\because \log_e |A|^m = m \log_e |A|] \\ &= 2f(x) \quad \left[\because f(x) = \log_e \left(\frac{1-x}{1+x} \right) \right] \end{aligned}$$

6. We have,

$$f_1(x) = \frac{1}{x}, f_2(x) = 1-x \text{ and } f_3(x) = \frac{1}{1-x}$$

Also, we have $(f_2 \circ J \circ f_1)(x) = f_3(x)$

$$\Rightarrow f_2((J \circ f_1)(x)) = f_3(x)$$

$$\Rightarrow f_2(J(f_1(x))) = f_3(x)$$

$$\Rightarrow 1 - J(f_1(x)) = \frac{1}{1-x}$$

$$[\because f_2(x) = 1-x \text{ and } f_3(x) = \frac{1}{1-x}]$$

$$\Rightarrow 1 - J\left(\frac{1}{x}\right) = \frac{1}{1-x} \quad [\because f_1(x) = \frac{1}{x}]$$

$$\begin{aligned} \Rightarrow J\left(\frac{1}{x}\right) &= 1 - \frac{1}{1-x} \\ &= \frac{1-x-1}{1-x} = \frac{-x}{1-x} \end{aligned}$$

Now, put $\frac{1}{x} = X$, then

$$J(X) = \frac{-1}{1 - \frac{1}{X}} \quad \left[\because x = \frac{1}{X} \right]$$

$$= \frac{-1}{X-1} = \frac{1}{1-X}$$

$$\Rightarrow J(X) = f_3(X) \text{ or } J(x) = f_3(x)$$

7. We have, $f(x) = ax^2 + bx + c$

Now, $f(x+y) = f(x) + f(y) + xy$

Put $y=0 \Rightarrow f(x) = f(x) + f(0) + 0$

$$\Rightarrow f(0) = 0$$

$$\Rightarrow c = 0$$

Again, put $y = -x$

$$\therefore f(0) = f(x) + f(-x) - x^2$$

$$\Rightarrow 0 = ax^2 + bx + ax^2 - bx - x^2$$

$$\Rightarrow 2ax^2 - x^2 = 0$$

$$\Rightarrow a = \frac{1}{2}$$

Also, $a + b + c = 3$

$$\Rightarrow \frac{1}{2} + b + 0 = 3 \Rightarrow b = \frac{5}{2}$$

$$\therefore f(x) = \frac{x^2 + 5x}{2}$$

$$\text{Now, } f(n) = \frac{n^2 + 5n}{2} = \frac{1}{2}n^2 + \frac{5}{2}n$$

$$\begin{aligned} \therefore \sum_{n=1}^{10} f(n) &= \frac{1}{2} \sum_{n=1}^{10} n^2 + \frac{5}{2} \sum_{n=1}^{10} n \\ &= \frac{1}{2} \cdot \frac{10 \times 11 \times 21}{6} + \frac{5}{2} \times \frac{10 \times 11}{2} \\ &= \frac{385}{2} + \frac{275}{2} = \frac{660}{2} = 330 \end{aligned}$$

8. $f(x) = x^2$, $g(x) = \sin x$

$$(g \circ f)(x) = \sin x^2$$

$$go(gof)(x) = \sin(\sin x^2)$$

$$(fogogof)(x) = (\sin(\sin x^2))^2 \quad \dots(i)$$

Again, $(g \circ f)(x) = \sin x^2$

$$(gogof)(x) = \sin(\sin x^2) \quad \dots(ii)$$

Given, $(fogogof)(x) = (gogof)(x)$

$$\Rightarrow (\sin(\sin x^2))^2 = \sin(\sin x^2)$$

$$\Rightarrow \sin(\sin x^2) \{ \sin(\sin x^2) - 1 \} = 0$$

$$\Rightarrow \sin(\sin x^2) = 0 \text{ or } \sin(\sin x^2) = 1$$

$$\Rightarrow \sin x^2 = 0 \text{ or } \sin x^2 = \frac{\pi}{2}$$

$$\therefore x^2 = n\pi$$

$$[\sin x^2 = \frac{\pi}{2} \text{ is not possible as } -1 \leq \sin \theta \leq 1]$$

$$x = \pm \sqrt{n\pi}$$

9. Given, $f(x) = \frac{\alpha x}{x+1}$

$$f[f(x)] = f\left(\frac{\alpha x}{x+1}\right) = \frac{\alpha\left(\frac{\alpha x}{x+1}\right)}{\frac{\alpha x}{x+1} + 1}$$

$$= \frac{\frac{\alpha^2 x}{x+1}}{\frac{\alpha x + (x+1)}{x+1}} = \frac{\alpha^2 x}{(\alpha + 1)x + 1} = x \text{ [given] ... (i)}$$

$$\Rightarrow \alpha^2 x = (\alpha + 1)x^2 + x$$

$$\Rightarrow x[\alpha^2 - (\alpha + 1)x - 1] = 0$$

$$\Rightarrow x(\alpha + 1)(\alpha - 1 - x) = 0$$

$$\Rightarrow \alpha - 1 = 0 \quad \text{and} \quad \alpha + 1 = 0$$

$$\Rightarrow \alpha = -1$$

But $\alpha = 1$ does not satisfy the Eq. (i).

10. $g(x) = 1 + x - [x]$ is greater than 1

since $x - [x] > 0$

$f[g(x)] = 1$, since $f(x) = 1$ for all $x > 0$

11. Let $f(x) = \sin^2 x$ and $g(x) = \sqrt{x}$

Now, $f \circ g(x) = f[g(x)] = f(\sqrt{x}) = \sin^2 \sqrt{x}$

and $g \circ f(x) = g[f(x)] = g(\sin^2 x) = \sqrt{\sin^2 x} = |\sin x|$

Again, let $f(x) = \sin x$, $g(x) = |x|$

$$f \circ g(x) = f[g(x)] = f(|x|)$$

$$= \sin |x| \neq (\sin \sqrt{x})^2$$

When $f(x) = x^2$, $g(x) = \sin \sqrt{x}$

$$f \circ g(x) = f[g(x)] = f(\sin \sqrt{x}) = (\sin \sqrt{x})^2$$

and $(g \circ f)(x) = g[f(x)] = g(x^2) = \sin \sqrt{x^2}$

$$= \sin |x| \neq |\sin x|$$

12. Given, $f(x) = \cos(\log x)$

$$\therefore f(x) \cdot f(y) - \frac{1}{2} \left[f\left(\frac{x}{y}\right) + f(xy) \right]$$

$$= \cos(\log x) \cdot \cos(\log y) - \frac{1}{2} [\cos(\log x - \log y) + \cos(\log x + \log y)]$$

$$= \cos(\log x) \cdot \cos(\log y) - \frac{1}{2} [2 \cos(\log x) \cdot \cos(\log y)]$$

$$= \cos(\log x) \cdot \cos(\log y) - \cos(\log x) \cdot \cos(\log y) = 0$$

13. Given, $f(x) = |x - 1|$

$$\therefore f(x^2) = |x^2 - 1|$$

and $\{f(x)\}^2 = (x - 1)^2$

$$\Rightarrow f(x^2) \neq \{f(x)\}^2, \text{ hence (a) is false.}$$

Also, $f(x + y) = |x + y - 1|$

and $f(x) = |x - 1|$,

$$f(y) = |y - 1|$$

$$\Rightarrow f(x + y) \neq f(x) + f(y), \text{ hence (b) is false.}$$

$$f(|x|) = ||x| - 1|$$

and $|f(x)| = ||x - 1|| = |x - 1|$

$\therefore f(|x|) \neq |f(x)|$, hence (c) is false.

14. $f(x) = \sin\left[\frac{\pi}{6} \sin\left(\frac{\pi}{2} \sin x\right)\right], x \in R$

$$= \sin\left(\frac{\pi}{6} \sin \theta\right), \theta \in \left[-\frac{\pi}{2}, \frac{\pi}{2}\right] \text{ where } \theta = \frac{\pi}{2} \sin x$$

$$= \sin \alpha, \alpha \in \left[-\frac{\pi}{6}, \frac{\pi}{6}\right], \text{ where } \alpha = \frac{\pi}{6} \sin \theta$$

$$\therefore f(x) \in \left[-\frac{1}{2}, \frac{1}{2}\right]$$

Hence, range of $f(x) \in \left[-\frac{1}{2}, \frac{1}{2}\right]$

So, option (a) is correct.

(b) $f\{g(x)\} = f(t), t \in \left[-\frac{\pi}{2}, \frac{\pi}{2}\right] \Rightarrow f(t) \in \left[-\frac{1}{2}, \frac{1}{2}\right]$

\therefore Option (b) is correct.

(c) $\lim_{x \rightarrow 0} \frac{f(x)}{g(x)} = \lim_{x \rightarrow 0} \frac{\sin\left[\frac{\pi}{6} \sin\left(\frac{\pi}{2} \sin x\right)\right]}{\frac{\pi}{2} (\sin x)}$

$$= \lim_{x \rightarrow 0} \frac{\sin\left[\frac{\pi}{6} \sin\left(\frac{\pi}{2} \sin x\right)\right]}{\frac{\pi}{6} \sin\left(\frac{\pi}{2} \sin x\right)} \cdot \frac{\frac{\pi}{6} \sin\left(\frac{\pi}{2} \sin x\right)}{\left(\frac{\pi}{2} \sin x\right)}$$

$$= 1 \times \frac{\pi}{6} \times 1 = \frac{\pi}{6}$$

\therefore Option (c) is correct.

(d) $g\{f(x)\} = 1$

$$\Rightarrow \frac{\pi}{2} \sin\{f(x)\} = 1$$

$$\Rightarrow \sin\{f(x)\} = \frac{2}{\pi} \quad \dots (i)$$

But $f(x) \in \left[-\frac{1}{2}, \frac{1}{2}\right] \subset \left[-\frac{\pi}{6}, \frac{\pi}{6}\right]$

$$\therefore \sin\{f(x)\} \in \left[-\frac{1}{2}, \frac{1}{2}\right] \quad \dots (ii)$$

$$\Rightarrow \sin\{f(x)\} \neq \frac{2}{\pi}, \quad \text{[from Eqs. (i) and (ii)]}$$

i.e. No solution.

\therefore Option (d) is not correct.

15. Since, $f(x) = \cos[\pi^2]x + \cos[-\pi^2]x$

$$\Rightarrow f(x) = \cos(9)x + \cos(-10)x$$

[using $[\pi^2] = 9$ and $[-\pi^2] = -10$]

$$\therefore f\left(\frac{\pi}{2}\right) = \cos \frac{9\pi}{2} + \cos 5\pi = -1$$

$$f(\pi) = \cos 9\pi + \cos 10\pi = -1 + 1 = 0$$

$$f(-\pi) = \cos 9\pi + \cos 10\pi = -1 + 1 = 0$$

$$f\left(\frac{\pi}{4}\right) = \cos \frac{9\pi}{4} + \cos \frac{10\pi}{4} = \frac{1}{\sqrt{2}} + 0 = \frac{1}{\sqrt{2}}$$

Hence, (a) and (c) are correct options.

182 Functions

16. Since, area of equilateral triangle = $\frac{\sqrt{3}}{4} (BC)^2$

$$\Rightarrow \frac{\sqrt{3}}{4} = \frac{\sqrt{3}}{4} \cdot [x^2 + g^2(x)] \Rightarrow g^2(x) = 1 - x^2$$

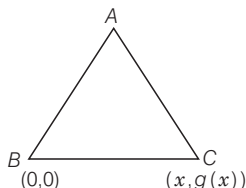

$$\Rightarrow g(x) = \sqrt{1 - x^2} \text{ or } -\sqrt{1 - x^2}$$

Hence, (b) and (c) are the correct options.

17. Given, $y = f(x) = \frac{x+2}{x-1}$

$$\Rightarrow yx - y = x + 2 \Rightarrow x(y - 1) = y + 2$$

$$\Rightarrow x = \frac{y+2}{y-1} \Rightarrow x = f(y)$$

Here, $f(1)$ does not exist, so domain $\in R - \{1\}$

$$\frac{dy}{dx} = \frac{(x-1) \cdot 1 - (x+2) \cdot 1}{(x-1)^2} = -\frac{3}{(x-1)^2}$$

$\Rightarrow f(x)$ is decreasing for all $x \in R - \{1\}$.

Also, f is rational function of x .

Hence, (a) and (d) are correct options.

18. $f(x) = \sin^2 x + \sin^2(x + \pi/3) + \cos x \cos(x + \pi/3)$

$$\Rightarrow f(x) = \sin^2 x + (\sin x \cos \pi/3 + \cos x \sin \pi/3)^2 + \cos x \cos(x + \pi/3)$$

$$\Rightarrow f(x) = \sin^2 x + \left(\frac{\sin x \cdot 1}{2} + \frac{\cos x \cdot \sqrt{3}}{2} \right)^2 + \cos x (\cos x \cos \pi/3 - \sin x \sin \pi/3)$$

$$\Rightarrow f(x) = \sin^2 x + \frac{\sin^2 x}{4} + \frac{3 \cos^2 x}{4} + \frac{2 \cdot \sqrt{3}}{4} \sin x \cos x + \frac{\cos^2 x}{2} - \cos x \sin x \cdot \frac{\sqrt{3}}{2}$$

$$= \sin^2 x + \frac{\sin^2 x}{4} + \frac{3 \cos^2 x}{4} + \frac{\cos^2 x}{2} = \frac{5}{4} \sin^2 x + \frac{5}{4} \cos^2 x = \frac{5}{4}$$

and $gof(x) = g\{f(x)\} = g(5/4) = 1$

Alternate Solution

$$\begin{aligned} f(x) &= \sin^2 x + \sin^2(x + \pi/3) + \cos x \cos(x + \pi/3) \\ \Rightarrow f'(x) &= 2 \sin x \cos x + 2 \sin(x + \pi/3) \cos(x + \pi/3) \\ &\quad - \sin x \cos(x + \pi/3) - \cos x \sin(x + \pi/3) \\ &= \sin 2x + \sin(2x + 2\pi/3) - [\sin(x + x + \pi/3)] \\ &= 2 \sin\left(\frac{2x + 2x + 2\pi/3}{2}\right) \cdot \cos\left(\frac{2x - 2x - 2\pi/3}{2}\right) \\ &= 2 [\sin(2x + \pi/3) \cdot \cos \pi/3] - \sin(2x + \pi/3) \end{aligned}$$

$$= 2 \left[\sin(2x + \pi/3) \cdot \frac{1}{2} \right] - \sin\left(2x + \frac{\pi}{3}\right) = 0$$

$\Rightarrow f(x) = c$, where c is a constant.

But $f(0) = \sin^2 0 + \sin^2(\pi/3) + \cos 0 \cos \pi/3$

$$= \left(\frac{\sqrt{3}}{2}\right)^2 + \frac{1}{2} = \frac{3}{4} + \frac{1}{2} = \frac{5}{4}$$

Therefore, $(gof)(x) = g[f(x)] = g(5/4) = 1$

19. Given, $f(x) = (a - x^n)^{1/n}$

$$\Rightarrow f[f(x)] = [a - \{(a - x^n)^{1/n}\}^n]^{1/n} = (x^n)^{1/n} = x$$

$$\therefore f[f(x)] = x$$

Hence, given statement is true.

20. Let $f(n) = 2^n$ for all positive integers n .

Now, for $n = 1$, $f(1) = 2 = 2^1$

\Rightarrow It is true for $n = 1$.

Again, let $f(k)$ is true.

$$\Rightarrow f(k) = 2^k, \text{ for some } k \in N.$$

$$\begin{aligned} \text{Again, } f(k+1) &= f(k) \cdot f(1) && \text{[by definition]} \\ &= 2^k \cdot 2 && \text{[from induction assumption]} \\ &= 2^{k+1} \end{aligned}$$

Therefore, the result is true for $n = k + 1$. Hence, by principle of mathematical induction,

$$f(n) = 2^n, \forall n \in N$$

$$\begin{aligned} \text{Now, } \sum_{k=1}^n f(a+k) &= \sum_{k=1}^n f(a) f(k) = f(a) \sum_{k=1}^n 2^k \\ &= f(a) \cdot \frac{2(2^n - 1)}{2 - 1} \\ &= 2^a \cdot 2(2^n - 1) = 2^{a+1}(2^n - 1) \end{aligned}$$

$$\text{But } \sum_{k=1}^n f(a+k) = 16(2^n - 1) = 2^4(2^n - 1)$$

$$\text{Therefore, } a + 1 = 4 \Rightarrow a = 3$$

21. The given function $f: [0, 1] \rightarrow R$ be define by

$$f(x) = \frac{4^x}{4^x + 2} \Rightarrow f(1-x) = \frac{4^{1-x}}{4^{1-x} + 2} = \frac{2}{2 + 4^x}$$

$$\therefore f(x) + f(1-x) = \frac{4^x}{4^x + 2} + \frac{2}{2 + 4^x} = \frac{4^x + 2}{4^x + 2}$$

$$\text{So, } f(x) + f(1-x) = 1 \quad \dots (i)$$

$$\begin{aligned} \therefore f\left(\frac{1}{40}\right) + f\left(\frac{2}{40}\right) + f\left(\frac{3}{40}\right) + \dots + f\left(\frac{39}{40}\right) &= f\left(\frac{1}{2}\right) \\ &= \left[f\left(\frac{1}{40}\right) + f\left(\frac{39}{40}\right) \right] + \left[f\left(\frac{2}{40}\right) + f\left(\frac{38}{40}\right) \right] \\ &\quad + \dots + \left[f\left(\frac{18}{40}\right) + f\left(\frac{22}{40}\right) \right] + \left[f\left(\frac{19}{40}\right) + f\left(\frac{21}{40}\right) \right] \\ &\quad + f\left(\frac{20}{40}\right) - f\left(\frac{1}{2}\right) \\ &= \{1 + 1 + \dots + 1 + 1\} + f\left(\frac{1}{2}\right) - f\left(\frac{1}{2}\right) \text{ [from Eq. (i)]} \end{aligned}$$

$$19 - \text{times} = 19.$$

Topic 3 Types of Functions

1. The given function $f : R \rightarrow R$ is

$$f(x) = |x|(x - \sin x) \quad \dots (i)$$

\therefore The function 'f' is an odd and continuous function and as $\lim_{x \rightarrow \infty} f(x) = \infty$ and $\lim_{x \rightarrow -\infty} f(x) = -\infty$, so range is R ,

therefore 'f' is an onto function.

$$\therefore f(x) = \begin{cases} x(x - \sin x), & x \geq 0 \\ -x(x - \sin x), & x < 0 \end{cases}$$

$$\therefore f'(x) = \begin{cases} 2x - \sin x - x \cos x, & x > 0 \\ -2x + \sin x + x \cos x, & x < 0 \end{cases}$$

$$\begin{cases} (x - \sin x) + x(1 - \cos x), & x > 0 \\ (-x + \sin x) - x(1 - \cos x), & x < 0 \end{cases}$$

\therefore for $x > 0$, $x - \sin x > 0$ and $x(1 - \cos x) > 0$

$\therefore f'(x) > 0 \forall x \in (0, \infty)$

$\Rightarrow f$ is strictly increasing function, $\forall x \in (0, \infty)$.

Similarly, for $x < 0$, $-x + \sin x > 0$

and $(-x)(1 - \cos x) > 0$, therefore, $f'(x) > 0 \forall x \in (-\infty, 0)$

$\Rightarrow f$ is strictly increasing function, $\forall x \in (-\infty, 0)$

Therefore 'f' is a strictly increasing function for $x \in R$ and it implies that f is one-one function.

2. Given, function $f : R - \{1, -1\} \rightarrow A$ defined as

$$f(x) = \frac{x^2}{1-x^2} = y \quad (\text{let})$$

$$\Rightarrow x^2 = y(1-x^2) \quad [\because x^2 \neq 1]$$

$$\Rightarrow x^2(1+y) = y \Rightarrow x^2 = \frac{y}{1+y} \quad [\text{provided } y \neq -1]$$

$$\therefore x^2 \geq 0 \Rightarrow \frac{y}{1+y} \geq 0 \Rightarrow y \in (-\infty, -1) \cup [0, \infty)$$

Since, for surjective function, range of $f =$ codomain

\therefore Set A should be $R - [-1, 0)$.

3. We have, $f(x) = \frac{|x-1|}{x} = \begin{cases} -\frac{(x-1)}{x}, & \text{if } 0 < x \leq 1 \\ \frac{x-1}{x}, & \text{if } x > 1 \end{cases}$

$$= \begin{cases} \frac{1}{x} - 1, & \text{if } 0 < x \leq 1 \\ 1 - \frac{1}{x}, & \text{if } x > 1 \end{cases}$$

Now, let us draw the graph of $y = f(x)$

Note that when $x \rightarrow 0$, then $f(x) \rightarrow \infty$, when $x = 1$, then $f(x) = 0$, and when $x \rightarrow \infty$, then $f(x) \rightarrow 1$

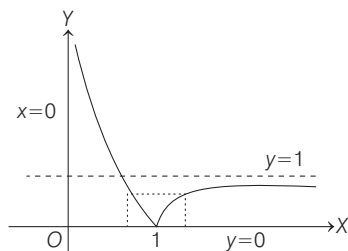

Clearly, $f(x)$ is not injective because if $f(x) < 1$, then f is many one, as shown in figure.

Also, $f(x)$ is not surjective because range of $f(x)$ is $[0, \infty[$ and but in problem co-domain is $(0, \infty)$, which is wrong.

$\therefore f(x)$ is neither injective nor surjective

4. According to given information, we have if

$$k \in \{4, 8, 12, 16, 20\}$$

$$\text{Then, } f(k) \in \{3, 6, 9, 12, 15, 18\}$$

$$[\because \text{Codomain } (f) = \{1, 2, 3, \dots, 20\}]$$

Now, we need to assign the value of $f(k)$

$k \in \{4, 8, 12, 16, 20\}$ this can be done in ${}^6C_5 \cdot 5!$ ways $= 6 \cdot 5! = 6!$ and remaining 15 element can be associated by $15!$ ways.

\therefore Total number of onto functions $= 15!6!$

5. We have, $f(x) = \frac{x}{1+x^2}, x \in R$

Ist Method $f(x)$ is an odd function and maximum occur at $x = 1$

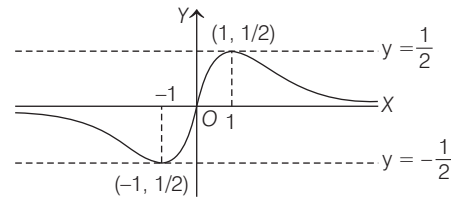

From the graph it is clear that range of $f(x)$ is $[-\frac{1}{2}, \frac{1}{2}]$

IInd Method $f(x) = \frac{1}{x + \frac{1}{x}}$

If $x > 0$, then by AM \geq GM, we get $x + \frac{1}{x} \geq 2$

$$\Rightarrow \frac{1}{x + \frac{1}{x}} \leq \frac{1}{2} \Rightarrow 0 < f(x) \leq \frac{1}{2}$$

If $x < 0$, then by AM \geq GM, we get $x + \frac{1}{x} \leq -2$

$$\Rightarrow \frac{1}{x + \frac{1}{x}} \geq -\frac{1}{2} \Rightarrow -\frac{1}{2} \leq f(x) < 0$$

If $x = 0$, then $f(x) = \frac{0}{1+0} = 0$. Thus, $-\frac{1}{2} \leq f(x) \leq \frac{1}{2}$

Hence, $f(x) \in [-\frac{1}{2}, \frac{1}{2}]$

IIIrd Method

$$\text{Let } y = \frac{x}{1+x^2} \Rightarrow yx^2 - x + y = 0$$

$$\therefore x \in R, \text{ so } D \geq 0 \Rightarrow 1 - 4y^2 \geq 0$$

$$\Rightarrow (1-2y)(1+2y) \geq 0 \Rightarrow y \in \left[-\frac{1}{2}, \frac{1}{2}\right]$$

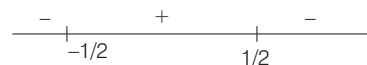

184 Functions

So, range is $\left[-\frac{1}{2}, \frac{1}{2}\right]$.

6. Given, $f(n) = \begin{cases} \frac{n+1}{2}, & \text{if } n \text{ is odd} \\ \frac{n}{2}, & \text{if } n \text{ is even,} \end{cases}$

and $g(n) = n - (-1)^n = \begin{cases} n+1, & \text{if } n \text{ is odd} \\ n-1, & \text{if } n \text{ is even} \end{cases}$

Now, $f(g(n)) = \begin{cases} f(n+1), & \text{if } n \text{ is odd} \\ f(n-1), & \text{if } n \text{ is even} \end{cases}$
 $= \begin{cases} \frac{n+1}{2}, & \text{if } n \text{ is odd} \\ \frac{n-1+1}{2} = \frac{n}{2}, & \text{if } n \text{ is even} \end{cases}$
 $= f(x)$

[∵ if n is odd, then $(n+1)$ is even and if n is even, then $(n-1)$ is odd]

Clearly, function is not one-one as $f(2) = f(1) = 1$

But it is onto function.

[∵ If $m \in N$ (codomain) is odd, then $2m \in N$ (domain) such that $f(2m) = m$ and if $m \in N$ codomain is even, then

$$2m-1 \in N \text{ (domain) such that } f(2m-1) = m]$$

∴ Function is onto but not one-one

7. We have a function $f: A \rightarrow R$ defined as, $f(x) = \frac{2x}{x-1}$

One-one Let $x_1, x_2 \in A$ such that

$$f(x_1) = f(x_2) \Rightarrow \frac{2x_1}{x_1-1} = \frac{2x_2}{x_2-1}$$

$$\Rightarrow 2x_1x_2 - 2x_1 = 2x_1x_2 - 2x_2 \Rightarrow x_1 = x_2$$

Thus, $f(x_1) = f(x_2)$ has only one solution, $x_1 = x_2$

∴ $f(x)$ is one-one (injective)

Onto Let $x = 2$, then $f(2) = \frac{2 \times 2}{2-1} = 4$

But $x = 2$ is not in the domain, and $f(x)$ is one-one function

∴ $f(x)$ can never be 4.

Similarly, $f(x)$ can not take many values.

Hence, $f(x)$ is into (not surjective).

∴ $f(x)$ is injective but not surjective.

8. We have, $f(x) = \frac{x}{1+x^2}$

$$\therefore f\left(\frac{1}{x}\right) = \frac{\frac{1}{x}}{1+\frac{1}{x^2}} = \frac{x}{1+x^2} = f(x)$$

$$\therefore f\left(\frac{1}{2}\right) = f(2) \text{ or } f\left(\frac{1}{3}\right) = f(3) \text{ and so on.}$$

So, $f(x)$ is many-one function.

Again, let $y = f(x) \Rightarrow y = \frac{x}{1+x^2}$

$$\Rightarrow y + x^2y = x \Rightarrow yx^2 - x + y = 0$$

As, $x \in R$

$$\therefore (-1)^2 - 4(y)(y) \geq 0 \Rightarrow 1 - 4y^2 \geq 0 \Rightarrow y \in \left[-\frac{1}{2}, \frac{1}{2}\right]$$

$$\therefore \text{Range} = \text{Codomain} = \left[-\frac{1}{2}, \frac{1}{2}\right]$$

So, $f(x)$ is surjective.

Hence, $f(x)$ is surjective but not injective.

9. **PLAN** To check nature of function.

(i) **One-one** To check one-one, we must check whether $f'(x) > 0$ or $f'(x) < 0$ in given domain.

(ii) **Onto** To check onto, we must check Range = Codomain

Description of Situation To find range in given domain $[a, b]$, put $f'(x) = 0$ and find $x = \alpha_1, \alpha_2, \dots, \alpha_n \in [a, b]$

Now, find $\{f(a), f(\alpha_1), f(\alpha_2), \dots, f(\alpha_n), f(b)\}$

its greatest and least values gives you range.

Now, $f: [0, 3] \rightarrow [1, 29]$

$$f(x) = 2x^3 - 15x^2 + 36x + 1$$

$$\therefore f'(x) = 6x^2 - 30x + 36 = 6(x^2 - 5x + 6)$$

$$= 6(x-2)(x-3)$$

$$\begin{array}{ccccccc} & & + & & - & & + \\ & & | & & | & & \\ & & 2 & & 3 & & \end{array}$$

For given domain $[0, 3]$, $f(x)$ is increasing as well as decreasing \Rightarrow many-one

Now, put $f'(x) = 0 \Rightarrow x = 2, 3$

Thus, for range $f(0) = 1, f(2) = 29, f(3) = 28$

\Rightarrow Range $\in [1, 29]$

∴ Onto but not one-one.

10. Let $\phi(x) = f(x) - g(x) = \begin{cases} x, & x \in Q \\ -x, & x \notin Q \end{cases}$

Now, to check one-one.

Take any straight line parallel to X -axis which will intersect $\phi(x)$ only at one point.

$\Rightarrow \phi(x)$ is one-one.

To check onto

As $f(x) = \begin{cases} x, & x \in Q \\ -x, & x \notin Q \end{cases}$, which shows

$y = x$ and $y = -x$ for rational and irrational values

$\Rightarrow y \in$ real numbers.

∴ Range = Codomain \Rightarrow onto

Thus, $f - g$ is one-one and onto.

11. Given, $f: [0, \infty) \rightarrow [0, \infty)$

Here, domain is $[0, \infty)$ and codomain is $[0, \infty)$. Thus, to check one-one

Since, $f(x) = \frac{x}{1+x} \Rightarrow f'(x) = \frac{1}{(1+x)^2} > 0, \forall x \in [0, \infty)$

∴ $f(x)$ is increasing in its domain. Thus, $f(x)$ is one-one in its domain. To check onto (we find range)

Again, $y = f(x) = \frac{x}{1+x} \Rightarrow y + yx = x$

$\Rightarrow x = \frac{y}{1-y} \Rightarrow \frac{y}{1-y} \geq 0$

Since, $x \geq 0$, therefore $0 \leq y < 1$

i.e. Range \neq Codomain

$\therefore f(x)$ is one-one but not onto.

12. Given, $f(x) = 2x + \sin x$

$\Rightarrow f'(x) = 2 + \cos x \Rightarrow f'(x) > 0, \forall x \in R$

which shows $f(x)$ is one-one, as $f(x)$ is strictly increasing.

Since, $f(x)$ is increasing for every $x \in R$,

$\therefore f(x)$ takes all intermediate values between $(-\infty, \infty)$.

Range of $f(x) \in R$.

Hence, $f(x)$ is one-to-one and onto.

13. The number of onto functions from

$E = \{1, 2, 3, 4\}$ to $F = \{1, 2\}$

= Total number of functions which map E to F

- Number of functions for which map $f(x) = 1$ and $f(x) = 2$ for all $x \in E = 2^4 - 2 = 14$

14. PLAN

- (i) For such questions, we need to properly define the functions and then we draw their graphs.
- (ii) From the graphs, we can examine the function for continuity, differentiability, one-one and onto.

$$f_1(x) = \begin{cases} -x, & x < 0 \\ e^x, & x \geq 0 \end{cases}$$

$$f_2(x) = x^2, x \geq 0$$

$$f_3(x) = \begin{cases} \sin x, & x < 0 \\ x, & x \geq 0 \end{cases}$$

$$f_4(x) = \begin{cases} f_2(f_1(x)), & x < 0 \\ f_2(f_1(x)) - 1, & x \geq 0 \end{cases}$$

Now, $f_2(f_1(x)) = \begin{cases} x^2, & x < 0 \\ e^{2x}, & x \geq 0 \end{cases} \Rightarrow f_4 = \begin{cases} x^2, & x < 0 \\ e^{2x} - 1, & x \geq 0 \end{cases}$

As $f_4(x)$ is continuous, $f'_4(x) = \begin{cases} 2x, & x < 0 \\ 2e^{2x}, & x > 0 \end{cases}$

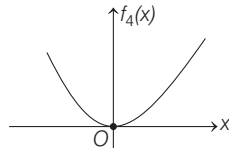

Graph for $f_4(x)$

$f'_4(0)$ is not defined. Its range is $[0, \infty)$.

Thus, range = codomain = $[0, \infty)$, thus f_4 is onto.

Also, horizontal line (drawn parallel to X-axis) meets the curve more than once, thus function is not one-one.

15. $y = 1 + 2x$ is linear function, therefore it is one-one and its range is $(-\pi + 1, \pi + 1)$. Therefore, $(1 + 2x)$ is one-one but not onto so (A) \rightarrow (q). Again, see the figure.

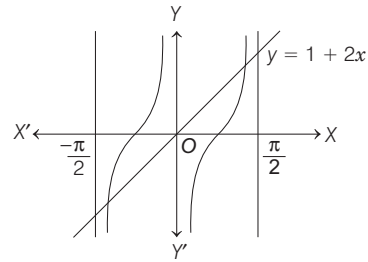

It is clear from the graph that $y = \tan x$ is one-one and onto, therefore (B) \rightarrow (r).

16. PLAN

- (i) If $f'(x) > 0, \forall x \in (a, b)$, then $f(x)$ is an increasing function in (a, b) and thus $f(x)$ is one-one function in (a, b) .
- (ii) If range of $f(x) =$ codomain of $f(x)$, then $f(x)$ is an onto function.
- (iii) A function $f(x)$ is said to be an odd function, if $f(-x) = -f(x), \forall x \in R$, i.e.

$$f(-x) + f(x) = 0, \forall x \in R$$

$$f(x) = [\ln(\sec x + \tan x)]^3$$

$$f'(x) = \frac{3 [\ln(\sec x + \tan x)]^2 (\sec x \tan x + \sec^2 x)}{(\sec x + \tan x)}$$

$$f'(x) = 3 \sec x [\ln(\sec x + \tan x)]^2 > 0, \forall x \in \left(-\frac{\pi}{2}, \frac{\pi}{2}\right)$$

$f(x)$ is an increasing function.

$\therefore f(x)$ is an one-one function.

$(\sec x + \tan x) = \tan\left(\frac{\pi}{4} + \frac{x}{2}\right)$, as $x \in \left(-\frac{\pi}{2}, \frac{\pi}{2}\right)$, then

$$0 < \tan\left(\frac{\pi}{4} + \frac{x}{2}\right) < \infty$$

$$0 < \sec x + \tan x < \infty \Rightarrow -\infty < \ln(\sec x + \tan x) < \infty$$

$$-\infty < [\ln(\sec x + \tan x)]^3 < \infty \Rightarrow -\infty < f(x) < \infty$$

Range of $f(x)$ is R and thus $f(x)$ is an onto function.

$$f(-x) = [\ln(\sec x - \tan x)]^3 = \left[\ln\left(\frac{1}{\sec x + \tan x}\right)\right]^3$$

$$f(-x) = -[\ln(\sec x + \tan x)]^3$$

$$f(x) + f(-x) = 0$$

$\Rightarrow f(x)$ is an odd function.

17. Let $y = ax + b$ and $y = cx + d$ be two linear functions.

When $x = -1, y = 0$ and $x = 1, y = 2$, then

$$0 = -a + b \quad \text{and} \quad a + b = 2 \Rightarrow a = b = 1$$

$$\therefore y = x + 1 \quad \dots(i)$$

Again, when $x = -1, y = 2$ and $x = 1, y = 0$, then

$$-c + d = 2 \quad \text{and} \quad c + d = 0$$

$$\Rightarrow d = 1 \quad \text{and} \quad c = -1 \Rightarrow y = -x + 1 \quad \dots(ii)$$

Hence, two linear functions are $y = x + 1$ and $y = -x + 1$

18. Given, $f(x) = \frac{x^2 + 4x + 30}{x^2 - 8x + 18}$

$$\Rightarrow f'(x) = \frac{\begin{bmatrix} (x^2 - 8x + 18)(2x + 4) \\ - (x^2 + 4x + 30)(2x - 8) \end{bmatrix}}{(x^2 - 8x + 18)^2}$$

$$\begin{aligned} &= \frac{2(-6x^2 - 12x + 156)}{(x^2 - 8x + 18)^2} \\ &= \frac{-12(x^2 + 2x - 26)}{(x^2 - 8x + 18)^2} \end{aligned}$$

which shows $f'(x)$ is positive and negative both.

$\therefore f(x)$ is many one.

Hence, given statement is true.

19. Let $y = \frac{\alpha x^2 + 6x - 8}{\alpha + 6x - 8x^2}$

$$\begin{aligned} \Rightarrow & \alpha y + 6xy - 8x^2 y = \alpha x^2 + 6x - 8 \\ \Rightarrow & -\alpha x^2 - 8x^2 y + 6xy - 6x + \alpha y + 8 = 0 \\ \Rightarrow & \alpha x^2 + 8x^2 y - 6xy + 6x - \alpha y - 8 = 0 \\ \Rightarrow & x^2(\alpha + 8y) + 6x(1 - y) - (8 + \alpha y) = 0 \end{aligned}$$

Since, x is real.

$$\begin{aligned} \Rightarrow & B^2 - 4AC \geq 0 \\ \Rightarrow & 36(1 - y)^2 + 4(\alpha + 8y)(8 + \alpha y) \geq 0 \\ \Rightarrow & 9(1 - 2y + y^2) + [8\alpha + (64 + \alpha^2)y + 8\alpha y^2] \geq 0 \\ \Rightarrow & y^2(9 + 8\alpha) + y(46 + \alpha^2) + 9 + 8\alpha \geq 0 \quad \dots(i) \end{aligned}$$

$$\Rightarrow A > 0, D \leq 0, \Rightarrow 9 + 8\alpha > 0$$

$$\text{and } (46 + \alpha^2)^2 - 4(9 + 8\alpha)^2 \leq 0$$

$$\Rightarrow \alpha > -9/8$$

$$\text{and } [46 + \alpha^2 - 2(9 + 8\alpha)][46 + \alpha^2 + 2(9 + 8\alpha)] \leq 0$$

$$\Rightarrow \alpha > -9/8$$

$$\text{and } (\alpha^2 - 16\alpha + 28)(\alpha^2 + 16\alpha + 64) \leq 0$$

$$\Rightarrow \alpha > -9/8$$

$$\text{and } [(\alpha - 2)(\alpha - 14)](\alpha + 8)^2 \leq 0 \Rightarrow \alpha > -9/8$$

$$\text{and } (\alpha - 2)(\alpha - 14) \leq 0 \quad [\because (\alpha + 8)^2 \geq 0]$$

$$\Rightarrow \alpha > -9/8 \text{ and } 2 \leq \alpha \leq 14 \Rightarrow 2 \leq \alpha \leq 14$$

$$\text{Thus, } f(x) = \frac{\alpha x^2 + 6x - 8}{\alpha + 6x - 8x^2} \text{ will be onto, if } 2 \leq \alpha \leq 14$$

Again, when $\alpha = 3$

$$\begin{aligned} f(x) &= \frac{3x^2 + 6x - 8}{3 + 6x - 8x^2}, \text{ in this case } f(x) = 0 \\ \Rightarrow & 3x^2 + 6x - 8 = 0 \\ \Rightarrow & x = \frac{-6 \pm \sqrt{36 + 96}}{6} = \frac{-6 \pm \sqrt{132}}{6} = \frac{1}{3}(-3 \pm \sqrt{33}) \end{aligned}$$

This shows that

$$f\left[\frac{1}{3}(-3 + \sqrt{33})\right] = f\left[\frac{1}{3}(-3 - \sqrt{33})\right] = 0$$

Therefore, f is not one-to-one.

20. Since, there is an injective mapping from A to B , each element of A has unique image in B .

Similarly, there is also an injective mapping from B to A , each element of B has unique image in A or in other words there is one to one onto mapping from A to B .

Thus, there is bijective mapping from A to B .

Topic 4 Inverse and Periodic Functions

1. Given function

$$f(x) = \frac{8^{2x} - 8^{-2x}}{8^{2x} + 8^{-2x}}, x \in (-1, 1) = \frac{8^{4x} - 1}{8^{4x} + 1} = y \text{ (let)}$$

On applying componendo and dividendo law, we get

$$8^{4x} = \frac{1 + y}{1 - y}$$

On applying logarithm having base '8' both sides, we get

$$\begin{aligned} 4x &= \log_8 \left(\frac{1 + y}{1 - y} \right) \\ \Rightarrow x &= \frac{1}{4} \log_8 \left(\frac{1 + y}{1 - y} \right) = \frac{1}{4} (\log_8 e) \log_e \left(\frac{1 + y}{1 - y} \right) \end{aligned}$$

{by base change property of logarithm

$$\log_a b = \log_a e \cdot \log_e b}$$

By interchanging the variables x and y , we get the inverse function of $f(x)$ and it is

$$f^{-1}(x) = \frac{1}{4} (\log_8 e) \log_e \left(\frac{1 + x}{1 - x} \right).$$

Hence, option (c) is correct.

2. Since, only (c) satisfy given definition

$$\text{i.e. } f\{f^{-1}(B)\} = B$$

$$\text{Only, if } B \subseteq f(x)$$

3. By definition of composition of function,

$$g(f(x)) = (\sin x + \cos x)^2 - 1, \text{ is invertible (i.e. bijective)}$$

$$\Rightarrow g\{f(x)\} = \sin 2x \text{ is bijective.}$$

We know, $\sin x$ is bijective, only when $x \in \left[-\frac{\pi}{2}, \frac{\pi}{2}\right]$.

$$\text{Thus, } g\{f(x)\} \text{ is bijective, if } -\frac{\pi}{2} \leq 2x \leq \frac{\pi}{2}$$

$$\Rightarrow -\frac{\pi}{4} \leq x \leq \frac{\pi}{4}$$

4. It is only to find the inverse.

$$\text{Let } y = f(x) = (x + 1)^2, \text{ for } x \geq -1$$

$$\pm \sqrt{y} = x + 1, \quad x \geq -1$$

$$\Rightarrow \sqrt{y} = x + 1 \Rightarrow y \geq 0, x + 1 \geq 0$$

$$\Rightarrow x = \sqrt{y} - 1 \Rightarrow f^{-1}(y) = \sqrt{y} - 1$$

$$\Rightarrow f^{-1}(x) = \sqrt{x} - 1 \Rightarrow x \geq 0$$

5. Let $y = x + \frac{1}{x} \Rightarrow y = \frac{x^2 + 1}{x} \Rightarrow xy = x^2 + 1$

$$\Rightarrow x^2 - xy + 1 = 0 \Rightarrow x = \frac{y \pm \sqrt{y^2 - 4}}{2}$$

$$\Rightarrow f^{-1}(y) = \frac{y \pm \sqrt{y^2 - 4}}{2} \Rightarrow f^{-1}(x) = \frac{x \pm \sqrt{x^2 - 4}}{2}$$

Since, the range of the inverse function is $[1, \infty)$, then

$$\text{we take } f^{-1}(x) = \frac{x + \sqrt{x^2 - 4}}{2}$$

If we consider $f^{-1}(x) = \frac{x - \sqrt{x^2 - 4}}{2}$, then $f^{-1}(x) > 1$

This is possible only if $(x - 2)^2 > x^2 - 4$
 $\Rightarrow x^2 + 4 - 4x > x^2 - 4 \Rightarrow 8 > 4x$
 $\Rightarrow x < 2$, where $x > 2$

Therefore, (a) is the answer.

6. Let $y = 2^{x(x-1)}$, where $y \geq 1$ as $x \geq 1$

Taking \log_2 on both sides, we get

$$\log_2 y = \log_2 2^{x(x-1)} \Rightarrow \log_2 y = x(x-1)$$

$$\Rightarrow x^2 - x - \log_2 y = 0$$

$$\Rightarrow x = \frac{1 \pm \sqrt{1 + 4 \log_2 y}}{2}$$

For $y \geq 1$, $\log_2 y \geq 0 \Rightarrow 4 \log_2 y \geq 0 \Rightarrow 1 + 4 \log_2 y \geq 1$
 $\Rightarrow \sqrt{1 + 4 \log_2 y} \geq 1 \Rightarrow -\sqrt{1 + 4 \log_2 y} \leq -1$
 $\Rightarrow 1 - \sqrt{1 + 4 \log_2 y} \leq 0$

But $x \geq 1$

So, $x = 1 - \sqrt{1 + 4 \log_2 y}$ is not possible.

Therefore, we take $x = \frac{1}{2}(1 + \sqrt{1 + 4 \log_2 y})$

$$\Rightarrow f^{-1}(y) = \frac{1}{2}(1 + \sqrt{1 + 4 \log_2 y})$$

$$\Rightarrow f^{-1}(x) = \frac{1}{2}(1 + \sqrt{1 + 4 \log_2 x})$$

7. Given, $f(x) = 3x - 5$ [given]

Let $y = f(x) = 3x - 5 \Rightarrow y + 5 = 3x$
 $\Rightarrow x = \frac{y + 5}{3} \Rightarrow f^{-1}(y) = \frac{y + 5}{3} \Rightarrow f^{-1}(x) = \frac{x + 5}{3}$

8. Clearly, $f(x) = x - [x] = \{x\}$ which has period 1.

And $\sin \frac{1}{x}$, $x \cos x$ are non-periodic functions.

9. Here, $f(x) = \frac{b-x}{1-bx}$, where $0 < b < 1, 0 < x < 1$

For function to be invertible, it should be one-one onto.

\therefore Check Range :

Let $f(x) = y \Rightarrow y = \frac{b-x}{1-bx}$

$$\Rightarrow y - bxy = b - x \Rightarrow x(1 - by) = b - y$$

$$\Rightarrow x = \frac{b-y}{1-by}, \text{ where } 0 < x < 1$$

$$\therefore 0 < \frac{b-y}{1-by} < 1 \Rightarrow \frac{b-y}{1-by} > 0 \text{ and } \frac{b-y}{1-by} < 1$$

$$\Rightarrow y < b \text{ or } y > \frac{1}{b} \quad \dots(i)$$

$$\frac{(b-1)(y+1)}{1-by} < 0 - 1 < y < \frac{1}{b} \quad \dots(ii)$$

From Eqs. (i) and (ii), we get

$$y \in \left(-1, \frac{1}{b}\right) \subset \text{Codomain}$$

10. Given, $F(x) = \int \sin^2 x \, dx = \int \frac{1 - \cos 2x}{2} \, dx$

$$F(x) = \frac{1}{4}(2x - \sin 2x) + C \Rightarrow F(x + \pi) \neq F(x)$$

Hence, Statement I is false.

But Statement II is true as $\sin^2 x$ is periodic with period π .

11. It gives three cases

Case I When $f(x) = 1$ is true.

In this case, remaining two are false.

$$\therefore f(y) = 1 \text{ and } f(z) = 2$$

This means x and y have the same image, so $f(x)$ is not an injective, which is a contradiction.

Case II When $f(y) \neq 1$ is true.

If $f(y) \neq 1$ is true, then the remaining statements are false.

$$\therefore f(x) \neq 1 \text{ and } f(z) = 2$$

i.e. both x and y are not mapped to 1. So, either both associate to 2 or 3. Thus, it is not injective.

Case III When $f(z) \neq 2$ is true.

If $f(z) \neq 2$ is true, then remaining statements are false.

$$\therefore \text{If } f(x) \neq 1 \text{ and } f(y) = 1$$

But f is injective.

Thus, we have $f(x) = 2, f(y) = 1$ and $f(z) = 3$

Hence, $f^{-1}(1) = y$

12. Since, f is an even function,

then $f(-x) = f(x), \forall x \in (-5, 5)$

Given, $f(x) = f\left(\frac{x+1}{x+2}\right) \quad \dots(i)$

$$\Rightarrow f(-x) = f\left(\frac{-x+1}{-x+2}\right)$$

$$\Rightarrow f(x) = f\left(\frac{-x+1}{-x+2}\right) \quad [\because f(-x) = f(x)]$$

Taking f^{-1} on both sides, we get

$$x = \frac{-x+1}{-x+2} \Rightarrow -x^2 + 2x = -x + 1$$

$$\Rightarrow x^2 - 3x + 1 = 0 \Rightarrow x = \frac{3 \pm \sqrt{9-4}}{2} = \frac{3 \pm \sqrt{5}}{2}$$

Again, $f(x) = f\left(\frac{x+1}{x+2}\right)$

$$\Rightarrow f(-x) = f\left(\frac{x+1}{x+2}\right) \quad [\because f(-x) = f(x)]$$

Taking f^{-1} on both sides, we get

$$-x = \frac{x+1}{x+2} \Rightarrow x^2 + 3x + 1 = 0$$

$$\Rightarrow x = \frac{-3 \pm \sqrt{9-4}}{2} = \frac{-3 \pm \sqrt{5}}{2}$$

Therefore, four values of x are $\frac{\pm 3 \pm \sqrt{5}}{2}$.

9

Limit, Continuity and Differentiability

Topic 1 $\frac{0}{0}$ and $\frac{\infty}{\infty}$ Form

Objective Questions I (Only one correct option)

- $\lim_{x \rightarrow 0} \frac{x + 2 \sin x}{\sqrt{x^2 + 2 \sin x + 1} - \sqrt{\sin^2 x - x + 1}}$ is
 (2019 Main, 12 April II)
 (a) 6 (b) 2 (c) 3 (d) 1
- If $\lim_{x \rightarrow 1} \frac{x^2 - ax + b}{x - 1} = 5$, then $a + b$ is equal to
 (2019 Main, 10 April II)
 (a) -4 (b) 1 (c) -7 (d) 5
- If $\lim_{x \rightarrow 1} \frac{x^4 - 1}{x - 1} = \lim_{x \rightarrow k} \frac{x^3 - k^3}{x^2 - k^2}$, then k is
 (2019 Main, 10 April I)
 (a) $\frac{4}{3}$ (b) $\frac{3}{8}$ (c) $\frac{3}{2}$ (d) $\frac{8}{3}$
- $\lim_{x \rightarrow 0} \frac{\sin^2 x}{\sqrt{2} - \sqrt{1 + \cos x}}$ equals
 (2019 Main, 8 April I)
 (a) $4\sqrt{2}$ (b) $\sqrt{2}$
 (c) $2\sqrt{2}$ (d) 4
- $\lim_{x \rightarrow \frac{\pi}{4}} \frac{\cot^3 x - \tan x}{\cos\left(x + \frac{\pi}{4}\right)}$ is
 (2019 Main, 12 Jan I)
 (a) $4\sqrt{2}$ (b) 4 (c) 8 (d) $8\sqrt{2}$
- $\lim_{x \rightarrow 0} \frac{x \cot(4x)}{\sin^2 x \cot^2(2x)}$ is equal to
 (2019 Main, 11 Jan II)
 (a) 0 (b) 1 (c) 4 (d) 2
- $\lim_{y \rightarrow 0} \frac{\sqrt{1 + \sqrt{1 + y^4}} - \sqrt{2}}{y^4}$
 (2019 Main, 9 Jan I)
 (a) exists and equals $\frac{1}{4\sqrt{2}}$
 (b) does not exist
 (c) exists and equals $\frac{1}{2\sqrt{2}}$
 (d) exists and equals $\frac{1}{2\sqrt{2}(\sqrt{2} + 1)}$
- $\lim_{x \rightarrow \pi/2} \frac{\cot x - \cos x}{(\pi - 2x)^3}$ equals
 (2017 Main)
 (a) $\frac{1}{24}$ (b) $\frac{1}{16}$
 (c) $\frac{1}{8}$ (d) $\frac{1}{4}$
- $\lim_{x \rightarrow 0} \frac{\sin(\pi \cos^2 x)}{x^2}$ is equal to
 (2014 Main)
 (a) $\frac{\pi}{2}$ (b) 1 (c) $-\pi$ (d) π
- $\lim_{x \rightarrow 0} \frac{(1 - \cos 2x)(3 + \cos x)}{x \tan 4x}$ is equal to
 (2013 Main)
 (a) 4 (b) 3 (c) 2 (d) $\frac{1}{2}$
- If $\lim_{x \rightarrow \infty} \left(\frac{x^2 + x + 1}{x + 1} - ax - b \right) = 4$, then
 (2012)
 (a) $a = 1, b = 4$ (b) $a = 1, b = -4$
 (c) $a = 2, b = -3$ (d) $a = 2, b = 3$
- $\lim_{h \rightarrow 0} \frac{f(2h + 2 + h^2) - f(2)}{f(h - h^2 + 1) - f(1)}$, given that $f'(2) = 6$ and $f'(1) = 4$,
 (2003, 2M)
 (a) does not exist (b) is equal to $-3/2$
 (c) is equal to $3/2$ (d) is equal to 3
- If $\lim_{x \rightarrow 0} \frac{\{(a - n)nx - \tan x\} \sin nx}{x^2} = 0$, where n is non-zero real number, then a is equal to
 (2003, 2M)
 (a) 0 (b) $\frac{n + 1}{n}$ (c) n (d) $n + \frac{1}{n}$
- The integer n for which $\lim_{x \rightarrow 0} \frac{(\cos x - 1)(\cos x - e^x)}{x^n}$ is a finite non-zero number, is
 (2002, 2M)
 (a) 1 (b) 2
 (c) 3 (d) 4
- $\lim_{x \rightarrow 0} \frac{x \tan 2x - 2x \tan x}{(1 - \cos 2x)^2}$ is
 (1999, 2M)
 (a) 2 (b) -2
 (c) $\frac{1}{2}$ (d) $-\frac{1}{2}$

16. $\lim_{x \rightarrow 1} \frac{\sqrt{1 - \cos 2(x-1)}}{x-1}$ (1998, 2M)
- (a) exists and it equals $\sqrt{2}$
 (b) exists and it equals $-\sqrt{2}$
 (c) does not exist because $x - 1 \rightarrow 0$
 (d) does not exist because left hand limit is not equal to right hand limit

17. The value of $\lim_{x \rightarrow 0} \frac{\sqrt{\frac{1}{2}(1 - \cos^2 x)}}{x}$ is (1991, 2M)
- (a) 1 (b) -1
 (c) 0 (d) None of these

18. If $f(x) = \begin{cases} \frac{\sin[x]}{[x]}, & [x] \neq 0 \\ 0, & [x] = 0 \end{cases}$
- where, $[x]$ denotes the greatest integer less than or equal to x , then $\lim_{x \rightarrow 0} f(x)$ equals (1985, 2M)
- (a) 1 (b) 0
 (c) -1 (d) None of these

19. $\lim_{n \rightarrow \infty} \left(\frac{1}{1-n^2} + \frac{2}{1-n^2} + \dots + \frac{n}{1-n^2} \right)$ is equal to (1984, 2M)
- (a) 0 (b) $-\frac{1}{2}$
 (c) $\frac{1}{2}$ (d) None of these

20. If $f(a) = 2, f'(a) = 1, g(a) = -1, g'(a) = 2$, then the value of $\lim_{x \rightarrow a} \frac{g(x)f(a) - g(a)f(x)}{x-a}$ is (1983, 1M)
- (a) -5 (b) $\frac{1}{5}$
 (c) 5 (d) None of these

21. If $G(x) = -\sqrt{25 - x^2}$, then $\lim_{x \rightarrow 1} \frac{G(x) - G(1)}{x-1}$ has the value (1983, 1M)
- (a) $\frac{1}{\sqrt{24}}$ (b) $\frac{1}{5}$
 (c) $-\sqrt{24}$ (d) None of these

Objective Questions II

(One or more than one correct option)

22. For any positive integer n , define $f_n: (0, \infty) \rightarrow R$ as $f_n(x) = \sum_{j=1}^n \tan^{-1} \left(\frac{1}{1 + (x+j)(x+j-1)} \right)$ for all $x \in (0, \infty)$. (Here, the inverse trigonometric function $\tan^{-1} x$ assumes values in $\left(-\frac{\pi}{2}, \frac{\pi}{2}\right)$). Then, which of the following statement(s) is (are) TRUE? (2018 Adv.)
- (a) $\sum_{j=1}^5 \tan^2(f_j(0)) = 55$
 (b) $\sum_{j=1}^{10} (1 + f'_j(0)) \sec^2(f_j(0)) = 10$
 (c) For any fixed positive integer $n, \lim_{x \rightarrow \infty} \tan(f_n(x)) = \frac{1}{n}$
 (d) For any fixed positive integer $n, \lim_{x \rightarrow \infty} \sec^2(f_n(x)) = 1$

23. Let $L = \lim_{x \rightarrow 0} \frac{a - \sqrt{a^2 - x^2} - \frac{x^2}{4}}{x^4}, a > 0$. If L is finite, then (2009)
- (a) $a = 2$
 (b) $a = 1$
 (c) $L = \frac{1}{64}$
 (d) $L = \frac{1}{32}$

Fill in the Blanks

24. $\lim_{h \rightarrow 0} \frac{\log(1+2h) - 2 \log(1+h)}{h^2} = \dots$ (1997C, 2M)
25. If $f(x) = \begin{cases} \sin x, & x \neq n\pi, n = 0, \pm 1, \pm 2, \dots \\ 2, & \text{otherwise} \end{cases}$
- and $g(x) = \begin{cases} x^2 + 1, & x \neq 0, 2 \\ 4, & x = 0 \\ 5, & x = 2 \end{cases}$, then $\lim_{x \rightarrow 0} g[f(x)]$ is (1996, 2M)
26. ABC is an isosceles triangle inscribed in a circle of radius r . If $AB = AC$ and h is the altitude from A to BC , then the ΔABC has perimeter $P = 2(\sqrt{2hr - h^2} + \sqrt{2hr})$ and area $A = \dots$. Also, $\lim_{h \rightarrow 0} \frac{A}{P^3} = \dots$ (1989, 2M)

27. $\lim_{x \rightarrow -\infty} \left[\frac{\left(x^4 \sin\left(\frac{1}{x}\right) + x^2 \right)}{(1 + |x|^3)} \right] = \dots$ (1987, 2M)
28. Let $f(x) = \begin{cases} (x^3 + x^2 - 16x + 20)/(x-2)^2, & \text{if } x \neq 2 \\ k, & \text{if } x = 2 \end{cases}$. If $f(x)$ is continuous for all x , then $k = \dots$ (1981, 2M)
29. $\lim_{x \rightarrow 1} (1-x) \tan \frac{\pi x}{2} = \dots$ (1978, 2M)

True/False

30. If $\lim_{x \rightarrow a} [f(x)g(x)]$ exists, then both $\lim_{x \rightarrow a} f(x)$ and $\lim_{x \rightarrow a} g(x)$ exist. (1981, 2M)

Analytical & Descriptive Questions

31. Use the formula $\lim_{x \rightarrow 0} \frac{a^x - 1}{x} = \log_e a$, to find $\lim_{x \rightarrow 0} \frac{2^x - 1}{(1+x)^{1/2} - 1}$. (1982, 2M)
32. Evaluate $\lim_{h \rightarrow 0} \frac{(a+h)^2 \sin(a+h) - a^2 \sin a}{h}$. (1980, 3M)
33. Evaluate $\lim_{x \rightarrow 0} \sqrt{\frac{x - \sin x}{x + \cos^2 x}}$. (1979, 3M)
34. Evaluate $\lim_{x \rightarrow 1} \left(\frac{x-1}{2x^2 - 7x + 5} \right)$. (1978, 3M)

190 Limit, Continuity and Differentiability

Integer & Numerical Answer Type Questions

35. Let $\alpha, \beta \in \mathbb{R}$ be such that $\lim_{x \rightarrow 0} \frac{x^2 \sin(\beta x)}{\alpha x - \sin x} = 1$. Then, $6(\alpha + \beta)$ equals (2016 Adv.)

Topic 2 1^∞ Form, RHL and LHL

Objective Questions I (Only one correct option)

1. Let $f: \mathbb{R} \rightarrow \mathbb{R}$ be a differentiable function satisfying

$$f'(3) + f'(2) = 0. \text{ Then } \lim_{x \rightarrow 0} \left(\frac{1 + f(3+x) - f(3)}{1 + f(2-x) - f(2)} \right)^{\frac{1}{x}} \text{ is equal}$$

to (2019 Main, 8 April II)

- (a) e (b) e^{-1} (c) e^2 (d) 1
2. $\lim_{x \rightarrow 1^-} \frac{\sqrt{\pi} - \sqrt{2 \sin^{-1} x}}{\sqrt{1-x}}$ is equal to (2019 Main, 12 Jan II)

(a) $\sqrt{\frac{\pi}{2}}$ (b) $\sqrt{\frac{2}{\pi}}$ (c) $\sqrt{\pi}$ (d) $\frac{1}{\sqrt{2\pi}}$

3. Let $[x]$ denote the greatest integer less than or equal to x . Then,

$$\lim_{x \rightarrow 0} \frac{\tan(\pi \sin^2 x) + (|x| - \sin(x[x]))^2}{x^2} \text{ (2019 Main, 11 Jan I)}$$

- (a) equals π (b) equals $\pi + 1$
(c) equals 0 (d) does not exist

4. For each $t \in \mathbb{R}$, let $[t]$ be the greatest integer less than or equal to t . Then,

$$\lim_{x \rightarrow 1^+} \frac{(1 - |x| + \sin |1 - x|) \sin\left(\frac{\pi}{2} [1 - x]\right)}{|1 - x| [1 - x]} \text{ (2019 Main, 10 Jan I)}$$

- (a) equals 0 (b) does not exist
(c) equals -1 (d) equals 1

5. For each $x \in \mathbb{R}$, let $[x]$ be the greatest integer less than or equal to x . Then,

$$\lim_{x \rightarrow 0^-} \frac{x([x] + |x|) \sin [x]}{|x|} \text{ is equal to (2019 Main, 9 Jan II)}$$

- (a) 0 (b) $\sin 1$
(c) $-\sin 1$ (d) 1

6. For each $t \in \mathbb{R}$, let $[t]$ be the greatest integer less than or equal to t . Then,

$$\lim_{x \rightarrow 0^+} x \left(\left[\frac{1}{x} \right] + \left[\frac{2}{x} \right] + \dots + \left[\frac{15}{x} \right] \right) \text{ (2018 Main)}$$

- (a) is equal to 0 (b) is equal to 15
(c) is equal to 120 (d) does not exist (in \mathbb{R})

7. Let $f(x) = \frac{1-x(1+|1-x|)}{|1-x|} \cos\left(\frac{1}{1-x}\right)$

for $x \neq 1$. Then

- (a) $\lim_{x \rightarrow 1^+} f(x) = 0$
(b) $\lim_{x \rightarrow 1^-} f(x)$ does not exist
(c) $\lim_{x \rightarrow 1^-} f(x) = 0$
(d) $\lim_{x \rightarrow 1^+} f(x)$ does not exist

36. Let m and n be two positive integers greater than 1. If

$$\lim_{\alpha \rightarrow 0} \left(\frac{e^{\cos(\alpha^n)} - e}{\alpha^m} \right) = -\left(\frac{e}{2}\right), \text{ then the value of } \frac{m}{n} \text{ is (2015 Adv.)}$$

8. Let $p = \lim_{x \rightarrow 0^+} (1 + \tan^2 \sqrt{x})^{1/2x}$, then $\log p$ is equal to (2016 Main)

(a) 2 (b) 1
(c) $\frac{1}{2}$ (d) $\frac{1}{4}$

9. Let $\alpha(a)$ and $\beta(a)$ be the roots of the equation $(\sqrt[3]{1+a}-1)x^2 - (\sqrt{1+a}-1)x + (\sqrt[6]{1+a}-1) = 0$, where $a > -1$. Then, $\lim_{a \rightarrow 0^+} \alpha(a)$ and $\lim_{a \rightarrow 0^+} \beta(a)$ are (2012)

(a) $-\frac{5}{2}$ and 1 (b) $-\frac{1}{2}$ and -1
(c) $-\frac{7}{2}$ and 2 (d) $-\frac{9}{2}$ and 3

10. If $\lim_{x \rightarrow 0} [1 + x \log(1 + b^2)]^{\frac{1}{x}} = 2b \sin^2 \theta$, $b > 0$

and $\theta \in (-\pi, \pi]$, then the value of θ is (2011)

(a) $\pm \frac{\pi}{4}$ (b) $\pm \frac{\pi}{3}$
(c) $\pm \frac{\pi}{6}$ (d) $\pm \frac{\pi}{2}$

11. For $x > 0$, $\lim_{x \rightarrow 0} \left[(\sin x)^{1/x} + \left(\frac{1}{x}\right)^{\sin x} \right]$ is (2006, 3M)

(a) 0 (b) -1
(c) 1 (d) 2

12. Let $f: \mathbb{R} \rightarrow \mathbb{R}$ be such that $f(1) = 3$ and $f'(1) = 6$. Then,

$$\lim_{x \rightarrow 0} \left[\frac{f(1+x)}{f(1)} \right]^{1/x} \text{ equals (2002, 2M)}$$

(a) 1 (b) $e^{\frac{1}{2}}$
(c) e^2 (d) e^3

13. For $x \in \mathbb{R}$, $\lim_{x \rightarrow \infty} \left(\frac{x-3}{x+2} \right)^x$ is equal to (2000, 2M)

(a) e (b) e^{-1}
(c) e^{-5} (d) e^5

Fill in the Blanks

14. $\lim_{x \rightarrow 0} \left(\frac{1+5x^2}{1+3x^2} \right)^{1/x^2} = \dots$ (1996, 1M)

15. $\lim_{x \rightarrow \infty} \left(\frac{x+6}{x+1} \right)^{x+4} = \dots$ (1991, 2M)

Analytical & Descriptive Question

16. Find $\lim_{x \rightarrow 0} \left\{ \tan\left(\frac{\pi}{4} + x\right) \right\}^{1/x}$. (1993, 2M)

Integer & Numerical Answer Type Questions

17. Let e denote the base of the natural logarithm. The value of the real number a for which the right hand limit

$$\lim_{x \rightarrow 0^+} \frac{(1-x)^{\frac{1}{x}} - e^{-1}}{x^a}$$

is equal to a non zero real number, is

(2020 Adv.)

18. The largest value of the non-negative integer a for which $\lim_{x \rightarrow 1} \left\{ \frac{-ax + \sin(x-1) + a}{x + \sin(x-1) - 1} \right\}^{\frac{1-x}{1-\sqrt{x}}} = \frac{1}{4}$ is

(2014 Adv.)

Topic 3 Squeeze, Newton-Leibnitz's Theorem and Limit Based on Converting infinite Series into Definite Integrals

Objective Questions I (Only one correct option)

1. If α and β are the roots of the equation

$$375x^2 - 25x - 2 = 0, \text{ then } \lim_{n \rightarrow \infty} \sum_{r=1}^n \alpha^r + \lim_{n \rightarrow \infty} \sum_{r=1}^n \beta^r \text{ is equal}$$

to (2019 Main, 12 April I)

- (a) $\frac{21}{346}$
- (b) $\frac{29}{358}$
- (c) $\frac{1}{12}$
- (d) $\frac{7}{116}$

2. $\lim_{x \rightarrow \frac{\pi}{4}} \frac{\int_2^{\sec^2 x} f(t) dt}{x^2 - \frac{\pi^2}{16}}$ equals

(2007, 3M)

- (a) $\frac{8}{\pi} f(2)$
- (b) $\frac{2}{\pi} f(2)$
- (c) $\frac{2}{\pi} f\left(\frac{1}{2}\right)$
- (d) $4f(2)$

3. $\lim_{n \rightarrow \infty} \frac{1}{n} \sum_{r=1}^{2n} \frac{r}{\sqrt{n^2 + r^2}}$ equals

(1999, 2M)

- (a) $1 + \sqrt{5}$
- (b) $\sqrt{5} - 1$
- (c) $-1 + \sqrt{2}$
- (d) $1 + \sqrt{2}$

Objective Question II

(One more than one correct option)

4. Let $f(x) = \lim_{n \rightarrow \infty} \left[\frac{n^n (x+n) \left(x + \frac{n}{2}\right) \dots \left(x + \frac{n}{n}\right)}{n! (x^2 + n^2) \left(x^2 + \frac{n^2}{4}\right) \dots \left(x^2 + \frac{n^2}{n^2}\right)} \right]^{\frac{x}{n}}$,

for all $x=0$. Then

(2016 Adv.)

- (a) $f\left(\frac{1}{2}\right) \geq f(1)$
- (b) $f\left(\frac{1}{3}\right) \leq f\left(\frac{2}{3}\right)$
- (c) $f'(2) \leq 0$
- (d) $\frac{f'(3)}{f(3)} \geq \frac{f'(2)}{f(2)}$

Integer & Numerical Answer Type Question

5. For each positive integer n , let

$$y_n = \frac{1}{n} ((n+1)(n+2) \dots (n+n))^{\frac{1}{n}}$$

For $x \in R$, let $[x]$ be the greatest integer less than or equal to x . If $\lim_{n \rightarrow \infty} y_n = L$, then the value of $[L]$ is

(2018 Adv.)

Fill in the Blank

6. $\lim_{x \rightarrow 0} \frac{\int_0^{x^2} \cos^2 t dt}{x \sin x} = \dots$

(1997C, 2M)

Topic 4 Continuity at a Point

Objective Questions I (Only one correct option)

1. If the function f defined on $\left(\frac{\pi}{6}, \frac{\pi}{3}\right)$ by

$$f(x) = \begin{cases} \sqrt{2} \cos x - 1, & x \neq \frac{\pi}{4} \\ \cot x - 1, & x = \frac{\pi}{4} \end{cases}$$

is continuous,

then k is equal to (2019 Main, 9 April I)

- (a) $\frac{1}{2}$
- (b) 2
- (c) 1
- (d) $\frac{1}{\sqrt{2}}$

2. The function $f(x) = [x]^2 - [x^2]$ (where, $[x]$ is the greatest integer less than or equal to x), is discontinuous at

(1999, 2M)

- (a) all integers
- (b) all integers except 0 and 1
- (c) all integers except 0
- (d) all integers except 1

3. Let $[.]$ denotes the greatest integer function and $f(x) = [\tan^2 x]$, then

(1993, 1M)

- (a) $\lim_{x \rightarrow 0} f(x)$ does not exist
- (b) $f(x)$ is continuous at $x = 0$
- (c) $f(x)$ is not differentiable at $x = 0$
- (d) $f'(0) = 1$

192 Limit, Continuity and Differentiability

4. The function $f(x) = [x] \cos\left(\frac{2x-1}{2}\right) \pi$, $[\]$ denotes the greatest integer function, is discontinuous at
 (a) all x (1993, 1M)
 (b) all integer points
 (c) no x
 (d) x which is not an integer
5. If $f(x) = x(\sqrt{x} + \sqrt{x+1})$, then (1985, 2M)
 (a) $f(x)$ is continuous but not differentiable at $x = 0$
 (b) $f(x)$ is differentiable at $x = 0$
 (c) $f(x)$ is not differentiable at $x = 0$
 (d) None of the above
6. The function $f(x) = \frac{\log(1+ax) - \log(1-bx)}{x}$ is not defined at $x = 0$. The value which should be assigned to f at $x = 0$, so that it is continuous at $x = 0$, is
 (a) $a - b$
 (b) $a + b$ (1983, 1M)
 (c) $\log a + \log b$
 (d) None of the above

Objective Questions II

(One or more than one correct option)

7. Let $[x]$ be the greatest integer less than or equals to x . Then, at which of the following point(s) the function $f(x) = x \cos(\pi(x + [x]))$ is discontinuous? (2017 Adv.)
 (a) $x = -1$
 (b) $x = 1$
 (c) $x = 0$
 (d) $x = 2$
8. For every pair of continuous function $f, g : [0, 1] \rightarrow R$ such that $\max\{f(x) : x \in [0, 1]\} = \max\{g(x) : x \in [0, 1]\}$. The correct statement(s) is (are) (2014 Adv.)
 (a) $[f(c)]^2 + 3f(c) = [g(c)]^2 + 3g(c)$ for some $c \in [0, 1]$
 (b) $[f(c)]^2 + f(c) = [g(c)]^2 + 3g(c)$ for some $c \in [0, 1]$
 (c) $[f(c)]^2 + 3f(c) = [g(c)]^2 + g(c)$ for some $c \in [0, 1]$
 (d) $[f(c)]^2 = [g(c)]^2$ for some $c \in [0, 1]$
9. For every integer n , let a_n and b_n be real numbers. Let function $f : R \rightarrow R$ be given by

$$f(x) = \begin{cases} a_n + \sin \pi x, & \text{for } x \in [2n, 2n + 1] \\ b_n + \cos \pi x, & \text{for } x \in (2n - 1, 2n) \end{cases}$$

for all integers n .

If f is continuous, then which of the following hold(s) for all n ? (2012)

- (a) $a_{n-1} - b_{n-1} = 0$
 (b) $a_n - b_n = 1$
 (c) $a_n - b_{n+1} = 1$
 (d) $a_{n-1} - b_n = -1$

Fill in the Blank

10. A discontinuous function $y = f(x)$ satisfying $x^2 + y^2 = 4$ is given by $f(x) = \dots$. (1982, 2M)

Analytical & Descriptive Questions

11. Let $f(x) = \begin{cases} \{1 + |\sin x|\}^{a/|\sin x|}, & \frac{\pi}{6} < x < 0 \\ b, & x = 0 \\ e^{\tan 2x / \tan 3x}, & 0 < x < \frac{\pi}{6} \end{cases}$

Determine a and b such that $f(x)$ is continuous at $x = 0$. (1994, 4M)

12. Let $f(x) = \begin{cases} \frac{1 - \cos 4x}{x^2}, & x < 0 \\ a, & x = 0 \\ \frac{\sqrt{x}}{\sqrt{16 + \sqrt{x} - 4}}, & x > 0 \end{cases}$

Determine the value of a if possible, so that the function is continuous at $x = 0$. (1990, 4M)

13. Find the values of a and b so that the function (1989)

$$f(x) = \begin{cases} x + a\sqrt{2} \sin x, & 0 \leq x \leq \pi/4 \\ 2x \cot x + b, & \pi/4 \leq x \leq \pi/2 \\ a \cos 2x - b \sin x, & \pi/2 < x \leq \pi \end{cases}$$

is continuous for $0 \leq x \leq \pi$.

14. Let $g(x)$ be a polynomial of degree one and $f(x)$ be

$$\text{defined by } f(x) = \begin{cases} g(x), & x \leq 0 \\ \left[\frac{(1+x)^{1/x}}{(2+x)} \right], & x > 0 \end{cases}$$

Find the continuous function $f(x)$ satisfying $f'(1) = f(-1)$. (1987, 6M)

15. Determine the values a, b, c , for which the function

$$f(x) = \begin{cases} \frac{\sin(a+1)x + \sin x}{x}, & \text{for } x < 0 \\ c, & \text{for } x = 0 \\ \frac{(x + bx^2)^{1/2} - x^{1/2}}{bx^{3/2}}, & \text{for } x > 0 \end{cases}$$

is continuous at $x = 0$.

(1982, 3M)

Match the Columns

16. Let $f_1 : R \rightarrow R, f_2 : \left(-\frac{\pi}{2}, \frac{\pi}{2}\right) \rightarrow R, f_3 : (-1, e^{\pi/2} - 2) \rightarrow R$ and

$f_4 : R \rightarrow R$ be functions defined by

(i) $f_1(x) = \sin(\sqrt{1 - e^{-x^2}})$,

(ii) $f_2(x) = \begin{cases} \frac{|\sin x|}{\tan^{-1} x} & \text{if } x \neq 0 \\ 1 & \text{if } x = 0 \end{cases}$, where the inverse

trigonometric function $\tan^{-1} x$ assumes values in $\left(-\frac{\pi}{2}, \frac{\pi}{2}\right)$.

(iii) $f_3(x) = [\sin(\log_e(x + 2))]$, where for $t \in R, [t]$ denotes the greatest integer less than or equal to t ,

(iv) $f_4(x) = \begin{cases} x^2 \sin\left(\frac{1}{x}\right) & \text{if } x \neq 0 \\ 0 & \text{if } x = 0 \end{cases}$

List-I	List-II
P. The function f_1 is	1. NOT continuous at $x=0$
Q. The function f_2 is	2. continuous at $x=0$ and NOT differentiable at $x=0$
R. The function f_3 is	3. differentiable at $x=0$ and its derivative is NOT continuous at $x=0$
S. The function f_4 is	4. differentiable at $x=0$ and its derivative is continuous at $x=0$

The correct option is

- (a) $P \rightarrow 2; Q \rightarrow 3; R \rightarrow 1; S \rightarrow 4$ (b) $P \rightarrow 4; Q \rightarrow 1; R \rightarrow 2; S \rightarrow 3$
 (c) $P \rightarrow 4; Q \rightarrow 2; R \rightarrow 1; S \rightarrow 3$ (d) $P \rightarrow 2; Q \rightarrow 1; R \rightarrow 4; S \rightarrow 3$

Topic 5 Continuity in a Domain

Objective Questions I (Only one correct option)

1. Let $f: R \rightarrow R$ be a continuously differentiable function such that $f(2) = 6$ and $f'(2) = \frac{1}{48}$. If $\int_6^{f(x)} 4t^3 dt = (x-2)g(x)$, then $\lim_{x \rightarrow 2} g(x)$ is equal to (2019 Main, 12 April I)
- (a) 18 (b) 24 (c) 12 (d) 36

2. If $f(x) = \begin{cases} \frac{\sin(p+1)x + \sin x}{x}, & x < 0 \\ q, & x = 0 \\ \frac{\sqrt{x+x^2} - \sqrt{x}}{x^{3/2}}, & x > 0 \end{cases}$,

is continuous at $x=0$, then the ordered pair (p, q) is equal to (2019 Main, 10 April I)

- (a) $\left(-\frac{3}{2}, -\frac{1}{2}\right)$ (b) $\left(-\frac{1}{2}, \frac{3}{2}\right)$
 (c) $\left(\frac{5}{2}, \frac{1}{2}\right)$ (d) $\left(-\frac{3}{2}, \frac{1}{2}\right)$
3. If the function $f(x) = \begin{cases} a|\pi-x|+1, & x \leq 5 \\ b|x-\pi|+3, & x > 5 \end{cases}$ is continuous at $x=5$, then the value of $a-b$ is (2019 Main, 9 April II)
- (a) $\frac{-2}{\pi+5}$ (b) $\frac{2}{\pi+5}$
 (c) $\frac{2}{\pi-5}$ (d) $\frac{2}{5-\pi}$
4. If $f(x) = [x] - \left[\frac{x}{4}\right]$, $x \in R$ where $[x]$ denotes the greatest integer function, then (2019 Main, 9 April II)
- (a) $\lim_{x \rightarrow 4^+} f(x)$ exists but $\lim_{x \rightarrow 4^-} f(x)$ does not exist
 (b) f is continuous at $x=4$

- (c) Both $\lim_{x \rightarrow 4^-} f(x)$ and $\lim_{x \rightarrow 4^+} f(x)$ exist but are not equal
 (d) $\lim_{x \rightarrow 4^-} f(x)$ exists but $\lim_{x \rightarrow 4^+} f(x)$ does not exist

5. Let $f: [-1, 3] \rightarrow R$ be defined as

$$f(x) = \begin{cases} |x| + [x], & -1 \leq x < 1 \\ x + |x|, & 1 \leq x < 2 \\ x + [x], & 2 \leq x \leq 3, \end{cases} \quad (2019 \text{ Main, 8 April II})$$

where, $[t]$ denotes the greatest integer less than or equal to t . Then, f is discontinuous at

- (a) four or more points
 (b) only two points
 (c) only three points
 (d) only one point
6. Let $f: R \rightarrow R$ be a function defined as

$$f(x) = \begin{cases} 5, & \text{if } x \leq 1 \\ a + bx, & \text{if } 1 < x < 3 \\ b + 5x, & \text{if } 3 \leq x < 5 \\ 30, & \text{if } x \geq 5 \end{cases}$$

Then, f is

(2019 Main, 9 Jan I)

- (a) continuous if $a = -5$ and $b = 10$
 (b) continuous if $a = 5$ and $b = 5$
 (c) continuous if $a = 0$ and $b = 5$
 (d) not continuous for any values of a and b
7. If $f(x) = \frac{1}{2}x - 1$, then on the interval $[0, \pi]$ (1989, 2M)
- (a) $\tan[f(x)]$ and $1/f(x)$ are both continuous
 (b) $\tan[f(x)]$ and $1/f(x)$ are both discontinuous
 (c) $\tan[f(x)]$ and $f^{-1}(x)$ are both continuous
 (d) $\tan[f(x)]$ is continuous but $1/f(x)$ is not continuous

194 Limit, Continuity and Differentiability

Objective Questions II

(One or more than one correct option)

8. The following functions are continuous on $(0, \pi)$
- (a) $\tan x$ (b) $\int_0^x t \sin \frac{1}{t} dt$ (1991, 2M)
- (c) $\begin{cases} 1, & 0 \leq x \leq 3\pi/4 \\ 2\sin \frac{2}{9}x, & \frac{3\pi}{4} < x < \pi \end{cases}$ (d) $\begin{cases} x \sin x, & 0 < x \leq \pi/2 \\ \frac{\pi}{2} \sin(\pi + x), & \frac{\pi}{2} < x < \pi \end{cases}$
9. Let $[x]$ denotes the greatest integer less than or equal to x . If $f(x) = [x \sin \pi x]$, then $f(x)$ is (1986, 2M)
- (a) continuous at $x = 0$ (b) continuous in $(-1, 0)$
 (c) differentiable at $x = 1$ (d) differentiable in $(-1, 1)$

Fill in the Blank

10. Let $f(x) = [x] \sin \left(\frac{\pi}{[x+1]} \right)$, where $[]$ denotes the greatest integer function. The domain of f is and

the points of discontinuity of f in the domain are..... . (1996, 2M)

Analytical & Descriptive Question

11. Let $f(x) = \begin{cases} \frac{x^2}{2}, & 0 \leq x < 1 \\ 2x^2 - 3x + \frac{3}{2}, & 1 \leq x \leq 2 \end{cases}$

Discuss the continuity of f, f' and f'' on $[0, 2]$. (1983, 2M)

Integer & Numerical Answer Type Question

12. If the function f defined on $\left(-\frac{1}{3}, \frac{1}{3}\right)$ by

$$f(x) = \begin{cases} \frac{1}{x} \log_e \left(\frac{1+3x}{1-2x} \right), & \text{when } x \neq 0 \\ k, & \text{when } x = 0 \end{cases}$$

is continuous, then k is equal to (2020 Main, 7 Jan II)

Topic 6 Continuity for Composition and Function

Objective Question II

(One or more than one correct option)

1. For the function $f(x) = x \cos \frac{1}{x}, x \geq 1$, (2009)
- (a) for atleast one x in the interval $[1, \infty), f(x+2) - f(x) < 2$
 (b) $\lim_{x \rightarrow \infty} f'(x) = 1$
 (c) for all x in the interval $[1, \infty), f(x+2) - f(x) > 2$
 (d) $f'(x)$ is strictly decreasing in the interval $[1, \infty)$

Analytical & Descriptive Questions

2. Let $f(x) = \begin{cases} x+a, & \text{if } x < 0 \\ |x-1|, & \text{if } x \geq 0 \end{cases}$
 and $g(x) = \begin{cases} x+1, & \text{if } x < 0 \\ (x-1)^2 + b, & \text{if } x \geq 0 \end{cases}$

where, a and b are non-negative real numbers. Determine the composite function gof . If $(gof)(x)$ is continuous for all real x determine the values of a and b . Further, for these values of a and b , is gof differentiable at $x=0$? Justify your answer. (2002, 5M)

3. Let $f(x)$ be a continuous and $g(x)$ be a discontinuous function. Prove that $f(x) + g(x)$ is a discontinuous function. (1987, 2M)
4. Let $f(x) = \begin{cases} 1+x, & 0 \leq x \leq 2 \\ 3-x, & 2 < x \leq 3 \end{cases}$

Determine the form of $g(x) = f[f(x)]$ and hence find the points of discontinuity of g , if any (1983, 2M)

5. Let $f(x+y) = f(x) + f(y)$ for all x and y . If the function $f(x)$ is continuous at $x=0$, then show that $f(x)$ is continuous at all x . (1981, 2M)

Topic 7 Differentiability at a Point

Objective Questions I (Only one correct option)

1. Let $f: R \rightarrow R$ be differentiable at $c \in R$ and $f(c) = 0$. If $g(x) = |f(x)|$, then at $x = c$, g is (2019 Main, 10 April I)
- (a) not differentiable
 (b) differentiable if $f'(c) \neq 0$
 (c) not differentiable if $f'(c) = 0$
 (d) differentiable if $f'(c) = 0$

2. If $f: R \rightarrow R$ is a differentiable function and

$$f(2) = 6, \text{ then } \lim_{x \rightarrow 2} \int_6^{f(x)} \frac{2t dt}{(x-2)} \text{ is } \quad (2019 \text{ Main, 9 April II})$$

- (a) $12f'(2)$ (b) 0 (c) $24f'(2)$ (d) $2f'(2)$

3. Let $f(x) = 15 - |x - 10|; x \in R$. Then, the set of all values of x , at which the function, $g(x) = f(f(x))$ is not differentiable, is (2019 Main, 9 April II)
- (a) $\{5, 10, 15, 20\}$ (b) $\{5, 10, 15\}$
 (c) $\{10\}$ (d) $\{10, 15\}$

4. Let S be the set of all points in $(-\pi, \pi)$ at which the function, $f(x) = \min \{\sin x, \cos x\}$ is not differentiable. Then, S is a subset of which of the following?
(2019 Main, 12 Jan I)
- (a) $\left\{-\frac{\pi}{4}, 0, \frac{\pi}{4}\right\}$ (b) $\left\{-\frac{\pi}{2}, -\frac{\pi}{4}, \frac{\pi}{4}, \frac{\pi}{2}\right\}$
(c) $\left\{-\frac{3\pi}{4}, -\frac{\pi}{4}, \frac{3\pi}{4}, \frac{\pi}{4}\right\}$ (d) $\left\{-\frac{3\pi}{4}, -\frac{\pi}{2}, \frac{\pi}{2}, \frac{3\pi}{4}\right\}$
5. Let K be the set of all real values of x , where the function $f(x) = \sin |x| - |x| + 2(x - \pi) \cos |x|$ is not differentiable. Then, the set K is equal to (2019 Main, 11 Jan II)
- (a) $\{0\}$ (b) ϕ (an empty set)
(c) $\{\pi\}$ (d) $\{0, \pi\}$
6. Let $f(x) = \begin{cases} -1, & -2 \leq x < 0 \\ x^2 - 1, & 0 \leq x \leq 2 \end{cases}$ and $g(x) = |f(x)| + f(|x|)$. Then, in the interval $(-2, 2)$, g is (2019 Main, 11 Jan I)
- (a) not differentiable at one point
(b) not differentiable at two points
(c) differentiable at all points
(d) not continuous
7. Let $f: (-1, 1) \rightarrow R$ be a function defined by $f(x) = \max\{-|x|, -\sqrt{1-x^2}\}$. If K be the set of all points at which f is not differentiable, then K has exactly (2019 Main, 10 Jan II)
- (a) three elements (b) five elements
(c) two elements (d) one element
8. Let $f(x) = \begin{cases} \max\{|x|, x^2\}, & |x| \leq 2 \\ 8 - 2|x|, & 2 < |x| \leq 4 \end{cases}$
Let S be the set of points in the interval $(-4, 4)$ at which f is not differentiable. Then, S (2019 Main, 10 Jan I)
- (a) equals $\{-2, -1, 0, 1, 2\}$
(b) equals $\{-2, 2\}$
(c) is an empty set
(d) equals $\{-2, -1, 1, 2\}$
9. Let f be a differentiable function from R to R such that $|f(x) - f(y)| \leq 2|x - y|^{\frac{3}{2}}$, for all $x, y \in R$. If $f(0) = 1$, then $\int_0^1 f^2(x) dx$ is equal to (2019 Main, 9 Jan II)
- (a) 2 (b) $\frac{1}{2}$ (c) 1 (d) 0
10. Let $S = \{t \in R : f(x) = |x - \pi|(e^{|x|} - 1) \sin |x| \text{ is not differentiable at } t\}$. Then, the set S is equal to (2018 Main)
- (a) ϕ (an empty set) (b) $\{0\}$
(c) $\{\pi\}$ (d) $\{0, \pi\}$
11. For $x \in R$, $f(x) = |\log 2 - \sin x|$ and $g(x) = f(f(x))$, then (2016 Main)
- (a) g is not differentiable at $x = 0$
(b) $g'(0) = \cos(\log 2)$
(c) $g'(0) = -\cos(\log 2)$
(d) g is differentiable at $x = 0$ and $g'(0) = -\sin(\log 2)$
12. If f and g are differentiable functions in $(0, 1)$ satisfying $f(0) = 2 = g(1)$, $g(0) = 0$ and $f(1) = 6$, then for some $c \in]0, 1[$ (2014 Main)
- (a) $2f'(c) = g'(c)$ (b) $2f'(c) = 3g'(c)$
(c) $f'(c) = g'(c)$ (d) $f'(c) = 2g'(c)$
13. Let $f(x) = \begin{cases} x^2 \cos \frac{\pi}{x}, & x \neq 0, x \in R \\ 0, & x = 0 \end{cases}$, then f is (2012)
- (a) differentiable both at $x = 0$ and at $x = 2$
(b) differentiable at $x = 0$ but not differentiable at $x = 2$
(c) not differentiable at $x = 0$ but differentiable at $x = 2$
(d) differentiable neither at $x = 0$ nor at $x = 2$
14. Let $g(x) = \frac{(x-1)^n}{\log \cos^m(x-1)}$; $0 < x < 2$, m and n are integers, $m \neq 0$, $n > 0$ and let p be the left hand derivative of $|x-1|$ at $x = 1$. If $\lim_{x \rightarrow 1^+} g(x) = p$, then (2008, 3M)
- (a) $n = 1, m = 1$ (b) $n = 1, m = -1$
(c) $n = 2, m = 2$ (d) $n > 2, m = n$
15. If f is a differentiable function satisfying $f\left(\frac{1}{n}\right) = 0, \forall n \geq 1, n \in I$, then (2005, 2M)
- (a) $f(x) = 0, x \in (0, 1]$
(b) $f'(0) = 0 = f(0)$
(c) $f(0) = 0$ but $f'(0)$ not necessarily zero
(d) $|f(x)| \leq 1, x \in (0, 1]$
16. Let $f(x) = ||x| - 1|$, then points where, $f(x)$ is not differentiable is/are (2005, 2M)
- (a) $0, \pm 1$ (b) ± 1
(c) 0 (d) 1
17. The domain of the derivative of the functions $f(x) = \begin{cases} \tan^{-1} x, & \text{if } |x| \leq 1 \\ \frac{1}{2}(|x| - 1), & \text{if } |x| > 1 \end{cases}$ is (2002, 2M)
- (a) $R - \{0\}$ (b) $R - \{1\}$
(c) $R - \{-1\}$ (d) $R - \{-1, 1\}$
18. Which of the following functions is differentiable at $x = 0$? (2001, 2M)
- (a) $\cos(|x|) + |x|$ (b) $\cos(|x|) - |x|$
(c) $\sin(|x|) + |x|$ (d) $\sin(|x|) - |x|$
19. The left hand derivative of $f(x) = [x] \sin(\pi x)$ at $x = k$, k is an integer, is (2001, 2M)
- (a) $(-1)^k (k-1)\pi$ (b) $(-1)^{k-1} (k-1)\pi$
(c) $(-1)^k k\pi$ (d) $(-1)^{k-1} k\pi$
20. Let $f: R \rightarrow R$ be a function defined by $f(x) = \max\{x, x^3\}$. The set of all points, where $f(x)$ is not differentiable, is (2001, 2M)
- (a) $\{-1, 1\}$ (b) $\{-1, 0\}$
(c) $\{0, 1\}$ (d) $\{-1, 0, 1\}$
21. Let $f: R \rightarrow R$ be any function. Define $g: R \rightarrow R$ by $g(x) = |f(x)|, \forall x$. Then, g is (2000, 2M)
- (a) onto if f is onto
(b) one-one if f is one-one
(c) continuous if f is continuous
(d) differentiable if f is differentiable
22. The function $f(x) = (x^2 - 1)|x^2 - 3x + 2| + \cos(|x|)$ is not differentiable at (1999, 2M)
- (a) -1 (b) 0 (c) 1 (d) 2

196 Limit, Continuity and Differentiability

23. The set of all points, where the function $f(x) = \frac{x}{1 + |x|}$ is differentiable, is (1987, 2M)
 (a) $(-\infty, \infty)$ (b) $[0, \infty)$
 (c) $(-\infty, 0) \cup (0, \infty)$ (d) $(0, \infty)$
24. There exists a function $f(x)$ satisfying $f(0) = 1$, $f'(0) = -1$, $f(x) > 0$, $\forall x$ and (1982, 2M)
 (a) $f''(x) < 0$, $\forall x$ (b) $-1 < f''(x) < 0$, $\forall x$
 (c) $-2 \leq f''(x) \leq -1$, $\forall x$ (d) $f''(x) < -2$, $\forall x$
25. For a real number y , let $[y]$ denotes the greatest integer less than or equal to y . Then, the function $f(x) = \frac{\tan \pi [(x - \pi)]}{1 + [x]^2}$ is (1981, 2M)
 (a) discontinuous at some x
 (b) continuous at all x , but the derivative $f'(x)$ does not exist for some x
 (c) $f'(x)$ exists for all x , but the derivative $f''(x)$ does not exist for some x
 (d) $f'(x)$ exists for all x

Objective Questions II

(One or more than one correct option)

26. Let $f: R \rightarrow R$ and $g: R \rightarrow R$ be functions satisfying $f(x + y) = f(x) + f(y) + f(x)f(y)$ and $f(x) = xg(x)$ for all $x, y \in R$. If $\lim_{x \rightarrow 0} g(x) = 1$, then which of the following statements is/are TRUE? (2020 Adv.)
 (a) f is differentiable at every $x \in R$
 (b) If $g(0) = 1$, then g is differentiable at every $x \in R$
 (c) The derivative $f'(1)$ is equal to 1
 (d) The derivative $f'(0)$ is equal to 1
27. Let the function $f: R \rightarrow R$ be defined by $f(x) = x^3 - x^2 + (x - 1)\sin x$ and let $g: R \rightarrow R$ be an arbitrary function. Let $fg: R \rightarrow R$ be the product function defined by $(fg)(x) = f(x)g(x)$. Then which of the following statements is/are TRUE? (2020 Adv.)
 (a) If g is continuous at $x = 1$, then fg is differentiable at $x = 1$
 (b) If fg is differentiable at $x = 1$, then g is continuous at $x = 1$
 (c) If g is differentiable at $x = 1$, then fg is differentiable at $x = 1$
 (d) If fg is differentiable at $x = 1$, then g is differentiable at $x = 1$
28. Let $f: R$ be a function. We say that f has
 PROPERTY 1 if $\lim_{h \rightarrow 0} \frac{f(h) - f(0)}{\sqrt{|h|}}$ exists and is finite, and
 PROPERTY 2 if $\lim_{h \rightarrow 0} \frac{f(h) - f(0)}{h^2}$ exists and is finite.
 Then which of the following options is/are correct? (2019 Adv.)
 (a) $f(x) = \sin x$ has PROPERTY 2
 (b) $f(x) = x^{2/3}$ has PROPERTY 1
 (c) $f(x) = |x|$ has PROPERTY 1
 (d) $f(x) = x|x|$ has PROPERTY 2
29. For every twice differentiable function $f: R \rightarrow [-2, 2]$ with $(f(0))^2 + (f'(0))^2 = 85$, which of the following statement(s) is (are) TRUE? (2018 Adv.)
 (a) There exist $r, s \in R$, where $r < s$, such that f is one-one on the open interval (r, s)
 (b) There exists $x_0 \in (-4, 0)$ such that $|f'(x_0)| \leq 1$
 (c) $\lim_{x \rightarrow \infty} f(x) = 1$
 (d) There exists $\alpha \in (-4, 4)$ such that $f(\alpha) + f''(\alpha) = 0$ and $f'(\alpha) \neq 0$
30. Let $f: (0, \pi) \rightarrow R$ be a twice differentiable function such that $\lim_{t \rightarrow x} \frac{f(x) \sin t - f(t) \sin x}{t - x} = \sin^2 x$ for all $x \in (0, \pi)$.
 If $f\left(\frac{\pi}{6}\right) = -\frac{\pi}{12}$, then which of the following statement(s) is (are) TRUE? (2018 Adv.)
 (a) $f\left(\frac{\pi}{4}\right) = \frac{\pi}{4\sqrt{2}}$
 (b) $f(x) < \frac{x^4}{6} - x^2$ for all $x \in (0, \pi)$
 (c) There exists $\alpha \in (0, \pi)$ such that $f'(\alpha) = 0$
 (d) $f''\left(\frac{\pi}{2}\right) + f\left(\frac{\pi}{2}\right) = 0$
31. Let $f: R \rightarrow R$, $g: R \rightarrow R$ and $h: R \rightarrow R$ be differentiable functions such that $f(x) = x^3 + 3x + 2$, $g(f(x)) = x$ and $h(g(g(x))) = x$ for all $x \in R$. Then, (2016 Adv.)
 (a) $g'(2) = \frac{1}{15}$ (b) $h'(1) = 666$
 (c) $h(0) = 16$ (d) $h(g(3)) = 36$
32. Let $a, b \in R$ and $f: R \rightarrow R$ be defined by $f(x) = a \cos(|x^3 - x|) + b|x| \sin(|x^3 + x|)$. Then, f is (2016 Adv.)
 (a) differentiable at $x = 0$, if $a = 0$ and $b = 1$
 (b) differentiable at $x = 1$, if $a = 1$ and $b = 0$
 (c) not differentiable at $x = 0$, if $a = 1$ and $b = 0$
 (d) not differentiable at $x = 1$, if $a = 1$ and $b = 1$
33. Let $f: \left[-\frac{1}{2}, 2\right] \rightarrow R$ and $g: \left[-\frac{1}{2}, 2\right] \rightarrow R$ be functions defined by $f(x) = [x^2 - 3]$ and $g(x) = |x|f(x) + |4x - 7|f(x)$, where $[y]$ denotes the greatest integer less than or equal to y for $y \in R$. Then, (2016 Adv.)
 (a) f is discontinuous exactly at three points in $\left[-\frac{1}{2}, 2\right]$
 (b) f is discontinuous exactly at four points in $\left[-\frac{1}{2}, 2\right]$
 (c) g is not differentiable exactly at four points in $\left(-\frac{1}{2}, 2\right)$
 (d) g is not differentiable exactly at five points in $\left(-\frac{1}{2}, 2\right)$
34. Let $g: R \rightarrow R$ be a differentiable function with $g(0) = 0$, $g'(0) = 0$ and $g'(1) \neq 0$. (2015 Adv.)
 Let $f(x) = \begin{cases} \frac{x}{|x|} g(x), & x \neq 0 \\ 0, & x = 0 \end{cases}$

and $h(x) = e^{|x|}$ for all $x \in R$. Let $(foh)(x)$ denotes $f\{h(x)\}$ and $(hof)(x)$ denotes $h\{f(x)\}$. Then, which of the following is/are true?

- (a) f is differentiable at $x = 0$
 (b) h is differentiable at $x = 0$
 (c) foh is differentiable at $x = 0$
 (d) hof is differentiable at $x = 0$

35. Let $f, g: [-1, 2] \rightarrow R$ be continuous functions which are twice differentiable on the interval $(-1, 2)$. Let the values of f and g at the points $-1, 0$ and 2 be as given in the following table:

	$x = -1$	$x = 0$	$x = 2$
$f(x)$	3	6	0
$g(x)$	0	1	-1

In each of the intervals $(-1, 0)$ and $(0, 2)$, the function $(f - 3g)''$ never vanishes. Then, the correct statement(s) is/are (2015 Adv.)

- (a) $f'(x) - 3g'(x) = 0$ has exactly three solutions in $(-1, 0) \cup (0, 2)$
 (b) $f'(x) - 3g'(x) = 0$ has exactly one solution in $(-1, 0)$
 (c) $f'(x) - 3g'(x) = 0$ has exactly one solution in $(0, 2)$
 (d) $f'(x) - 3g'(x) = 0$ has exactly two solutions in $(-1, 0)$ and exactly two solutions in $(0, 2)$

36. Let $f: [a, b] \rightarrow [1, \infty)$ be a continuous function and

$$g: R \rightarrow R \text{ be defined as } g(x) = \begin{cases} 0, & \text{if } x < a \\ \int_a^x f(t) dt, & \text{if } a \leq x \leq b \\ \int_a^b f(t) dt, & \text{if } x > b \end{cases}$$

Then,

- (a) $g(x)$ is continuous but not differentiable at a
 (b) $g(x)$ is differentiable on R
 (c) $g(x)$ is continuous but not differentiable at b
 (d) $g(x)$ is continuous and differentiable at either a or b but not both

37. If $f(x) = \begin{cases} -x - \frac{\pi}{2}, & x \leq -\frac{\pi}{2} \\ -\cos x, & -\frac{\pi}{2} < x \leq 0 \\ x - 1, & 0 < x \leq 1 \\ \ln x, & x > 1 \end{cases}$, then (2011)

- (a) $f(x)$ is continuous at $x = -\frac{\pi}{2}$
 (b) $f(x)$ is not differentiable at $x = 0$
 (c) $f(x)$ is differentiable at $x = 1$
 (d) $f(x)$ is differentiable at $x = -\frac{3}{2}$

38. Let $f: R \rightarrow R$ be a function such that

$f(x + y) = f(x) + f(y), \forall x, y \in R$. If $f(x)$ is differentiable at $x = 0$, then (2011)

- (a) $f(x)$ is differentiable only in a finite interval containing zero
 (b) $f(x)$ is continuous for all $x \in R$
 (c) $f'(x)$ is constant for all $x \in R$
 (d) $f(x)$ is differentiable except at finitely many points

39. If $f(x) = \min\{1, x^2, x^3\}$, then (2006, 3M)

- (a) $f(x)$ is continuous everywhere
 (b) $f(x)$ is continuous and differentiable everywhere
 (c) $f(x)$ is not differentiable at two points
 (d) $f(x)$ is not differentiable at one point

40. Let $h(x) = \min\{x, x^2\}$ for every real number of x , then

- (a) h is continuous for all x (1998, 2M)
 (b) h is differentiable for all x
 (c) $h'(x) = 1, \forall x > 1$
 (d) h is not differentiable at two values of x

41. The function $f(x) = \begin{cases} |x - 3|, & x \geq 1 \\ x^2 - \frac{3x}{2} + \frac{13}{4}, & x < 1 \end{cases}$ is (1988, 2M)

- (a) continuous at $x = 1$
 (b) differentiable at $x = 1$
 (c) discontinuous at $x = 1$
 (d) differentiable at $x = 3$

42. The function $f(x) = 1 + |\sin x|$ is (1986, 2M)

- (a) continuous no where
 (b) continuous everywhere
 (c) differentiable at $x = 0$
 (d) not differentiable at infinite number of points

43. If $x + |y| = 2y$, then y as a function of x is (1984, 2M)

- (a) defined for all real x
 (b) continuous at $x = 0$
 (c) differentiable for all x
 (d) such that $\frac{dy}{dx} = \frac{1}{3}$ for $x < 0$

Assertion and Reason

For the following questions, choose the correct answer from the codes (a), (b), (c) and (d) defined as follows.

- (a) Statement I is true, Statement II is also true; Statement II is the correct explanation of Statement I
 (b) Statement I is true, Statement II is also true; Statement II is not the correct explanation of Statement I
 (c) Statement I is true; Statement II is false
 (d) Statement I is false; Statement II is true

44. Let f and g be real valued functions defined on interval $(-1, 1)$ such that $g''(x)$ is continuous, $g(0) \neq 0, g'(0) = 0, g''(0) \neq 0$, and $f(x) = g(x)\sin x$.

Statement I $\lim_{x \rightarrow 0} [g(x)\cos x - g(0)\operatorname{cosec} x] = f''(0)$. and

Statement II $f'(0) = g(0)$. (2008, 3M)

198 Limit, Continuity and Differentiability

Match the Columns

45. In the following, $[x]$ denotes the greatest integer less than or equal to x .

Column I	Column II
A. $x x $	p. continuous in $(-1, 1)$
B. $\sqrt{ x }$	q. differentiable in $(-1, 1)$
C. $x + [x]$	r. strictly increasing $(-1, 1)$
D. $ x - 1 + x + 1 $, in $(-1, 1)$	s. not differentiable atleast at one point in $(-1, 1)$

(2007, 6M)

46. Match the conditions/expressions in Column I with statement in Column II (1992, 2M)

Column I	Column II
A. $\sin(\pi[x])$	p. differentiable everywhere
B. $\sin\{\pi(x - [x])\}$	q. no where differentiable
	r. not differentiable at 1 and -1

Fill in the Blanks

47. Let $F(x) = f(x)g(x)h(x)$ for all real x , where $f(x)$, $g(x)$ and $h(x)$ are differentiable functions. At same point x_0 , $F'(x_0) = 21F(x_0)$, $f'(x_0) = 4f(x_0)$, $g'(x_0) = -7g(x_0)$ and $h'(x_0) = kh(x_0)$, then $k = \dots$ (1997C, 2M)

48. For the function $f(x) = \begin{cases} \frac{x}{1 + e^{1/x}}, & x \neq 0; \\ 0, & x = 0 \end{cases}$

the derivative from the right, $f'(0^+) = \dots$ and the derivative from the left, $f'(0^-) = \dots$ (1983, 2M)

49. Let $f(x) = \begin{cases} (x-1)^2 \sin \frac{1}{(x-1)} - |x|, & \text{if } x \neq 1 \\ -1, & \text{if } x = 1 \end{cases}$ be a real valued function. Then, the set of points, where $f(x)$ is not differentiable, is (1981, 2M)

True/False

50. The derivative of an even function is always an odd function. (1983, 1M)

Analytical & Descriptive Questions

51. $f(x) = \begin{cases} b \sin^{-1}\left(\frac{x+c}{2}\right), & -\frac{1}{2} < x < 0 \\ \frac{1}{2}, & x = 0 \\ \frac{e^{ax/2} - 1}{x}, & 0 < x < \frac{1}{2} \end{cases}$

If $f(x)$ is differentiable at $x=0$ and $|c| < \frac{1}{2}$, then find the value of a and prove that $64b^2 = (4 - c^2)$. (2004, 4M)

52. If $f: [-1, 1] \rightarrow R$ and $f'(0) = \lim_{n \rightarrow \infty} nf\left(\frac{1}{n}\right)$ and $f(0) = 0$. Find the value of $\lim_{n \rightarrow \infty} \frac{2}{\pi} (n+1) \cos^{-1}\left(\frac{1}{n}\right) - n$, given that

$$0 < \left| \lim_{n \rightarrow \infty} \cos^{-1}\left(\frac{1}{n}\right) \right| < \frac{\pi}{2}. \quad (2004, 2M)$$

53. Let $\alpha \in R$. Prove that a function $f: R \rightarrow R$ is differentiable at α if and only if there is a function $g: R \rightarrow R$ which is continuous at α and satisfies $f(x) - f(\alpha) = g(x)(x - \alpha)$, $\forall x \in R$. (2001, 5M)

54. Determine the values of x for which the following function fails to be continuous or differentiable

$$f(x) = \begin{cases} 1 - x, & x < 1 \\ (1 - x)(2 - x), & 1 \leq x \leq 2. \text{ Justify your answer.} \\ 3 - x, & x > 2 \end{cases} \quad (1997, 5M)$$

55. Let $f(x) = \begin{cases} x e^{-\left(\frac{1}{|x|} + \frac{1}{x}\right)}, & x \neq 0 \\ 0, & x = 0 \end{cases}$

Test whether

(i) $f(x)$ is continuous at $x = 0$.

(ii) $f(x)$ is differentiable at $x = 0$. (1997C, 5M)

56. Let $f[(x+y)/2] = \{f(x) + f(y)\}/2$ for all real x and y , if $f'(0)$ exists and equals -1 and $f(0) = 1$, find $f(2)$. (1995, 5M)

57. A function $f: R \rightarrow R$ satisfies the equation $f(x+y) = f(x)f(y)$, $\forall x, y$ in R and $f(x) \neq 0$ for any x in R . Let the function be differentiable at $x=0$ and $f'(0) = 2$. Show that $f'(x) = 2f(x)$, $\forall x$ in R . Hence, determine $f(x)$. (1990, 4M)

58. Draw a graph of the function

$$y = [x] + |1 - x|, \quad -1 \leq x \leq 3.$$

Determine the points if any, where this function is not differentiable. (1989, 4M)

59. Let R be the set of real numbers and $f: R \rightarrow R$ be such that for all x and y in R , $|f(x) - f(y)|^2 \leq (x - y)^3$. Prove that $f(x)$ is a constant. (1988, 2M)

60. Let $f(x)$ be a function satisfying the condition $f(-x) = f(x)$, $\forall x$. If $f'(0)$ exists, find its value. (1987, 2M)

61. Let $f(x)$ be defined in the interval $[-2, 2]$ such that

$$f(x) = \begin{cases} -1, & -2 \leq x \leq 0 \\ x-1, & 0 < x \leq 2 \end{cases}$$

and $g(x) = f(|x|) + |f(x)|$.

Test the differentiability of $g(x)$ in $(-2, 2)$. (1986, 5M)

62. Let $f(x) = x^3 - x^2 - x + 1$

and $g(x) = \begin{cases} \max\{f(t); 0 \leq t \leq x\}, & 0 \leq x \leq 1 \\ 3 - x, & 1 < x \leq 2 \end{cases}$

Discuss the continuity and differentiability of the function $g(x)$ in the interval $(0, 2)$. (1985, 5M)

63. Find $f'(1)$, if $f(x) = \begin{cases} \frac{x-1}{2x^2-7x+5}, & \text{when } x \neq 1 \\ -\frac{1}{3}, & \text{when } x = 1 \end{cases}$. (1979, 3M)
64. If $f(x) = x \tan^{-1} x$, find $f'(1)$ from first principle. (1978, 3M)

Integer & Numerical Answer Type Questions

65. Let the functions $f : (-1, 1) \rightarrow \mathbf{R}$ and $g : (-1, 1) \rightarrow (-1, 1)$ be defined by $f(x) = |2x - 1| + |2x + 1|$ and $g(x) = x - [x]$, where $[x]$ denotes the greatest integer less than or equal to x . Let $f \circ g : (-1, 1) \rightarrow \mathbf{R}$ be the composite function defined by $(f \circ g)(x) = f(g(x))$. Suppose c is the number of points in the interval $(-1, 1)$ at which $f \circ g$ is NOT continuous, and suppose d is the number of points in the interval $(-1, 1)$ at which $f \circ g$ is NOT differentiable. Then the value of $c + d$ is (2020 Adv.)

66. Let $f : \mathbf{R} \rightarrow \mathbf{R}$ be a differentiable function such that $f(0) = 0, f\left(\frac{\pi}{2}\right) = 3$ and $f'(0) = 1$. If $g(x) = \int_x^{\frac{\pi}{2}} [f'(t) \operatorname{cosec} t - \cot t \operatorname{cosec} t f(t)] dt$ for $x \in \left(0, \frac{\pi}{2}\right]$, then $\lim_{x \rightarrow 0} g(x) =$ (2017 Adv.)
67. Let $f : \mathbf{R} \rightarrow \mathbf{R}$ and $g : \mathbf{R} \rightarrow \mathbf{R}$ be respectively given by $f(x) = |x| + 1$ and $g(x) = x^2 + 1$. Define $h : \mathbf{R} \rightarrow \mathbf{R}$ by $h(x) = \begin{cases} \max\{f(x), g(x)\}, & \text{if } x \leq 0 \\ \min\{f(x), g(x)\}, & \text{if } x > 0 \end{cases}$. The number of points at which $h(x)$ is not differentiable is (2014 Adv.)
68. Let $p(x)$ be a polynomial of degree 4 having extremum at $x = 1, 2$ and $\lim_{x \rightarrow 0} \left[1 + \frac{p(x)}{x^2}\right] = 2$. Then, the value of $p(2)$ is (2010)

Topic 8 Differentiation

Objective Questions I (Only one correct option)

1. If $(a + \sqrt{2b} \cos x)(a - \sqrt{2b} \cos y) = a^2 - b^2$, where $a > b > 0$, the $\frac{dx}{dy}$ at $\left(\frac{\pi}{4}, \frac{\pi}{4}\right)$ is (2020 Main, 4 Sep I)
- (a) $\frac{a-b}{a+b}$ (b) $\frac{a+b}{a-b}$ (c) $\frac{2a+b}{2a-b}$ (d) $\frac{a-2b}{a+2b}$
2. If ${}^{20}C_1 + (2^2) {}^{20}C_2 + (3^2) {}^{20}C_3 + \dots + (20^2) {}^{20}C_{20} = A(2^\beta)$, then the ordered pair (A, β) is equal to (2019 Main, 12 April II)
- (a) (420, 19) (b) (420, 18) (c) (380, 18) (d) (380, 19)
3. The derivative of $\tan^{-1}\left(\frac{\sin x - \cos x}{\sin x + \cos x}\right)$, with respect to $\frac{x}{2}$, where $\left(x \in \left(0, \frac{\pi}{2}\right)\right)$ is (2019 Main, 12 April II)
- (a) 1 (b) $\frac{2}{3}$ (c) $\frac{1}{2}$ (d) 2
4. If $e^y + xy = e$, the ordered pair $\left(\frac{dy}{dx}, \frac{d^2y}{dx^2}\right)$ at $x = 0$ is equal to (2019 Main, 12 April I)
- (a) $\left(\frac{1}{e}, -\frac{1}{e^2}\right)$ (b) $\left(-\frac{1}{e}, \frac{1}{e^2}\right)$ (c) $\left(\frac{1}{e}, \frac{1}{e^2}\right)$ (d) $\left(-\frac{1}{e}, -\frac{1}{e^2}\right)$
5. If $f(1) = 1, f'(1) = 3$, then the derivative of $f(f(f(x))) + (f(x))^2$ at $x = 1$ is (2019 Main, 8 April II)
- (a) 12 (b) 9 (c) 15 (d) 33
6. If $2y = \left(\cot^{-1}\left(\frac{\sqrt{3} \cos x + \sin x}{\cos x - \sqrt{3} \sin x}\right)\right)^2, x \in \left(0, \frac{\pi}{2}\right)$ then $\frac{dy}{dx}$ is equal to (2019 Main, 8 April I)
- (a) $\frac{\pi}{6} - x$ (b) $x - \frac{\pi}{6}$ (c) $\frac{\pi}{3} - x$ (d) $2x - \frac{\pi}{3}$

7. For $x > 1$, if $(2x)^{2y} = 4e^{2x-2y}$, then $(1 + \log_e 2x)^2 \frac{dy}{dx}$ is equal to (2019 Main, 12 Jan I)
- (a) $\frac{x \log_e 2x + \log_e 2}{x}$ (b) $\frac{x \log_e 2x - \log_e 2}{x}$
 (c) $x \log_e 2x$ (d) $\log_e 2x$
8. If $x \log_e(\log_e x) - x^2 + y^2 = 4 (y > 0)$, then $\frac{dy}{dx}$ at $x = e$ is equal to (2019 Main, 11 Jan I)
- (a) $\frac{e}{\sqrt{4+e^2}}$ (b) $\frac{(2e-1)}{2\sqrt{4+e^2}}$
 (c) $\frac{(1+2e)}{\sqrt{4+e^2}}$ (d) $\frac{(1+2e)}{2\sqrt{4+e^2}}$
9. Let $f : \mathbf{R} \rightarrow \mathbf{R}$ be a function such that $f(x) = x^3 + x^2 f'(1) + x f''(2) + f'''(3), x \in \mathbf{R}$. Then, $f(2)$ equals (2019 Main, 10 Jan I)
- (a) 30 (b) -4
 (c) -2 (d) 8
10. If $x = 3 \tan t$ and $y = 3 \sec t$, then the value of $\frac{d^2y}{dx^2}$ at $t = \frac{\pi}{4}$ is (2019 Main, 9 Jan II)
- (a) $\frac{1}{6}$ (b) $\frac{1}{6\sqrt{2}}$ (c) $\frac{1}{3\sqrt{2}}$ (d) $\frac{3}{2\sqrt{2}}$
11. For $x \in \left(0, \frac{1}{4}\right)$, if the derivative of $\tan^{-1}\left(\frac{6x\sqrt{x}}{1-9x^3}\right)$ is $\sqrt{x} \cdot g(x)$, then $g(x)$ equals (2017 Main)
- (a) $\frac{9}{1+9x^3}$ (b) $\frac{3x\sqrt{x}}{1-9x^3}$ (c) $\frac{3x}{1-9x^3}$ (d) $\frac{3}{1+9x^3}$

200 Limit, Continuity and Differentiability

12. If g is the inverse of a function f and $f'(x) = \frac{1}{1+x^5}$, then

$g'(x)$ is equal to (2015)

- (a) $1+x^5$ (b) $5x^4$ (c) $\frac{1}{1+\{g(x)\}^5}$ (d) $1+\{g(x)\}^5$

13. If $y = \sec(\tan^{-1} x)$, then $\frac{dy}{dx}$ at $x=1$ is equal to (2013)

- (a) $\frac{1}{\sqrt{2}}$ (b) $\frac{1}{2}$ (c) 1 (d) $\sqrt{2}$

14. Let $g(x) = \log f(x)$, where $f(x)$ is a twice differentiable positive function on $(0, \infty)$ such that $f(x+1) = x f(x)$.

Then, for $N = 1, 2, 3, \dots$, $g''\left(N + \frac{1}{2}\right) - g''\left(\frac{1}{2}\right)$ is equal to

- (a) $-4 \left\{ 1 + \frac{1}{9} + \frac{1}{25} + \dots + \frac{1}{(2N-1)^2} \right\}$ (2008, 3M)

- (b) $4 \left\{ 1 + \frac{1}{9} + \frac{1}{25} + \dots + \frac{1}{(2N-1)^2} \right\}$

- (c) $-4 \left\{ 1 + \frac{1}{9} + \frac{1}{25} + \dots + \frac{1}{(2N+1)^2} \right\}$

- (d) $4 \left\{ 1 + \frac{1}{9} + \frac{1}{25} + \dots + \frac{1}{(2N+1)^2} \right\}$

15. $\frac{d^2x}{dy^2}$ equals (2007, 3M)

- (a) $\left(\frac{d^2y}{dx^2}\right)^{-1}$ (b) $-\left(\frac{d^2y}{dx^2}\right)^{-1} \left(\frac{dy}{dx}\right)^{-3}$

- (c) $\left(\frac{d^2y}{dx^2}\right) \left(\frac{dy}{dx}\right)^{-2}$ (d) $-\left(\frac{d^2y}{dx^2}\right) \left(\frac{dy}{dx}\right)^{-3}$

16. If $f''(x) = -f(x)$, where $f(x)$ is a continuous double differentiable function and $g(x) = f'(x)$.

If $F(x) = \left\{ f\left(\frac{x}{2}\right) \right\}^2 + \left\{ g\left(\frac{x}{2}\right) \right\}^2$ and $F(5) = 5$,

then $F(10)$ is (2006, 3M)

- (a) 0 (b) 5 (c) 10 (d) 25

17. Let f be twice differentiable function satisfying $f(1) = 1, f(2) = 4, f(3) = 9$, then (2005, 2M)

- (a) $f''(x) = 2, \forall x \in (R)$

- (b) $f'(x) = 5 = f''(x)$, for some $x \in (1, 3)$

- (c) there exists atleast one $x \in (1, 3)$ such that $f''(x) = 2$

- (d) None of the above

18. If y is a function of x and $\log(x+y) = 2xy$, then the value of $y'(0)$ is (2004, 1M)

- (a) 1 (b) -1 (c) 2 (d) 0

19. If $x^2 + y^2 = 1$, then (2000, 1M)

- (a) $yy'' - 2(y')^2 + 1 = 0$ (b) $yy'' + (y')^2 + 1 = 0$

- (c) $yy'' + (y')^2 - 1 = 0$ (d) $yy'' + 2(y')^2 + 1 = 0$

20. Let $f(x) = \begin{vmatrix} x^3 & \sin x & \cos x \\ 6 & -1 & 0 \\ p & p^2 & p^3 \end{vmatrix}$, where p is constant.

Then, $\frac{d^3}{dx^3} f(x)$ at $x=0$ is (1997, 2M)

- (a) p (b) $p + p^2$
(c) $p + p^3$ (d) independent of p

21. If $y^2 = P(x)$ is a polynomial of degree 3, then

$2 \frac{d}{dx} \left(y^3 \frac{d^2y}{dx^2} \right)$ equals (1988, 2M)

- (a) $P'''(x) + P'(x)$ (b) $P''(x) \cdot P'''(x)$

- (c) $P(x) P'''(x)$ (d) a constant

Fill in the Blanks

22. If $x e^{xy} = y + \sin^2 x$, then at $x=0$, $\frac{dy}{dx} = \dots\dots$ (1996, 2M)

23. Let $f(x) = x|x|$. The set of points, where $f(x)$ is twice differentiable, is ... (1992, 2M)

24. If $f(x) = |x-2|$ and $g(x) = f[f(x)]$, then $g'(x) = \dots\dots$ for $x > 2$. (1990, 2M)

25. The derivative of $\sec^{-1} \left(-\frac{1}{2x^2-1} \right)$ with respect to

$\sqrt{1-x^2}$ at $x = \frac{1}{2}$ is (1986, 2M)

26. If $f(x) = \log_x(\log x)$, then $f'(x)$ at $x=e$ is (1985, 2M)

27. If $f_r(x), g_r(x), h_r(x), r = 1, 2, 3$ are polynomials in x such that $f_r(a) = g_r(a) = h_r(a), r = 1, 2, 3$

and $F(x) = \begin{vmatrix} f_1(x) & f_2(x) & f_3(x) \\ g_1(x) & g_2(x) & g_3(x) \\ h_1(x) & h_2(x) & h_3(x) \end{vmatrix}$,

then $F'(x)$ at $x=a$ is (1985, 2M)

28. If $y = f\left(\frac{2x-1}{x^2+1}\right)$ and $f'(x) = \sin^2 x$, then $\frac{dy}{dx} = \dots\dots$ (1982, 2M)

Analytical & Descriptive Questions

29. If $y = \frac{ax^2}{(x-a)(x-b)(x-c)} + \frac{bx}{(x-b)(x-c)} + \frac{c}{(x-c)} + 1$,

Prove that $\frac{y'}{y} = \frac{1}{x} \left(\frac{a}{a-x} + \frac{b}{b-x} + \frac{c}{c-x} \right)$. (1998, 8M)

30. Find $\frac{dy}{dx}$ at $x = -1$, when

$(\sin y)^{\sin \frac{\pi}{2} x} + \frac{\sqrt{3}}{2} \sec^{-1}(2x) + 2^x \tan \ln(x+2) = 0$. (1991, 4M)

31. If $x = \sec \theta - \cos \theta$ and $y = \sec^n \theta - \cos^n \theta$, then show that

$(x^2 + 4) \left(\frac{dy}{dx} \right)^2 = n^2 (y^2 + 4)$. (1989, 2M)

32. If α be a repeated roots of a quadratic equation $f(x) = 0$ and $A(x), B(x)$ and $C(x)$ be polynomials of degree 3, 4 and

5 respectively, then show that $\begin{vmatrix} A(x) & B(x) & C(x) \\ A(\alpha) & B(\alpha) & C(\alpha) \\ A'(\alpha) & B'(\alpha) & C'(\alpha) \end{vmatrix}$ is

divisible by $f(x)$, where prime denotes the derivatives. (1984, 4M)

33. Find the derivative with respect to x of the function

$$y = \left\{ (\log_{\cos x} \sin x) (\log_{\sin x} \cos x)^{-1} + \sin^{-1} \left(\frac{2x}{1+x^2} \right) \right\}$$

 at $x = \frac{\pi}{4}$. (1984, 4M)

34. If $(a + bx) e^{yx} = x$, then prove that

$$x^3 \frac{d^2y}{dx^2} = \left(x \frac{dy}{dx} - y \right)^2$$
. (1983, 3M)

35. Let f be a twice differentiable function such that (1983, 3M)
 $f''(x) = -f(x)$, $f'(x) = g(x)$ and
 $h(x) = [f(x)]^2 + [g(x)]^2$
 Find $h(10)$, if $h(5) = 11$.

36. Let $y = e^{x \sin x^3} + (\tan x)^x$, find $\frac{dy}{dx}$. (1981, 2M)

37. Given, $y = \frac{5x}{3\sqrt{(1-x)^2}} + \cos^2(2x+1)$, find $\frac{dy}{dx}$. (1980)

Integer & Numerical Answer Type Question

38. Let $f: R \rightarrow R$ be a continuous odd function, which vanishes exactly at one point and $f(1) = \frac{1}{2}$.

Suppose that $F(x) = \int_{-1}^x f(t) dt$ for all $x \in [-1, 2]$ and

$G(x) = \int_{-1}^x t |f(t)| dt$ for all $x \in [-1, 2]$. If

$\lim_{x \rightarrow 1} \frac{F(x)}{G(x)} = \frac{1}{14}$, then the value of $f\left(\frac{1}{2}\right)$ is (2015 Adv.)

Answers

Topic 1

- | | | | |
|--|---------------------------------------|------------|----------------|
| 1. (b) | 2. (c) | 3. (d) | 4. (a) |
| 5. (c) | 6. (b) | 7. (a) | 8. (b) |
| 9. (d) | 10. (c) | 11. (b) | 12. (d) |
| 13. (d) | 14. (c) | 15. (c) | 16. (c) |
| 17. (d) | 18. (d) | 19. (b) | 20. (c) |
| 21. (a) | 22. (d) | 23. (a, c) | 24. -1 |
| 25. 1 | 26. $h\sqrt{2hr-h^2}, \frac{1}{128r}$ | 27. -1 | |
| 28. 7 | 29. $\frac{2}{\pi}$ | 30. False | 31. $\log_e 4$ |
| 32. $a^2 \cos \alpha + 2a \sin \alpha$ | 33. 0 | | |
| 34. $-\frac{1}{3}$ | 35. (7) | 36. (2) | |

Topic 2

- | | | | |
|---------|-----------|-----------|-----------|
| 1. (d) | 2. (b) | 3. (d) | 4. (a) |
| 5. (c) | 6. (c) | 7. (d) | 8. (c) |
| 9. (b) | 10. (d) | 11. (c) | 12. (c) |
| 13. (c) | 14. e^2 | 15. e^5 | 16. e^2 |
| 17. (1) | 18. (2) | | |

Topic 3

- | | | | |
|--------|--------|--------|-----------|
| 1. (c) | 2. (a) | 3. (b) | 4. (b, c) |
| 5. (1) | 6. 1 | | |

Topic 4

- | | | | |
|------------------------------------|---------------------------|--|-----------|
| 1. (a) | 2. (b) | 3. (b) | 4. (c) |
| 5. (c) | 6. (b) | 7. (a, b, d) | 8. (a, d) |
| 9. (b, d) | 10. $f(x) = \sqrt{4-x^2}$ | | |
| 11. $a = \frac{2}{3}, b = e^{2/3}$ | 12. $a = 8$ | 13. $a = \frac{\pi}{6}, b = \frac{-\pi}{12}$ | |

$$14. f(x) = \begin{cases} \frac{2}{3} \left(\log \left(\frac{2}{3} \right) - \frac{1}{6} \right) x, & x \leq 0 \\ \left(\frac{1+x}{2+x} \right)^{1/x}, & x > 0 \end{cases}$$

15. $a = \frac{-3}{2}, c = \frac{1}{2}$ and $b \in R$ 16. (d)

Topic 5

- | | | | |
|--|---|--------|-----------|
| 1. (a) | 2. (d) | 3. (d) | 4. (b) |
| 5. (c) | 6. (d) | 7. (b) | 8. (b, c) |
| 9. (a, b, d) | 10. $x \in (-\infty, -1) \cup [0, \infty), [-1, 0]$ | | |
| 11. f and f'' are continuous and f' is discontinuous at $x = \{1, 2\}$. | | | |
| 12. (5) | | | |

Topic 6

1. (b, c, d)
2. $g\{f(x)\} = \begin{cases} x+a+1, & \text{if } x < -a \\ (x+a-1)^2, & \text{if } a \leq x < c \\ x^2+b, & \text{if } 0 \leq x \leq 1 \\ (x-2)^2+b, & \text{if } x > 1 \end{cases}$
- $a = 1, b = 0$
 $g \circ f$ is differentiable at $x = 0$
4. $g(x) = \begin{cases} 4-x, & 2 < x \leq 3 \\ 2+x, & 0 \leq x \leq 1, \text{ discontinuous at } x = \{1, 2\} \\ 2-x, & 1 < x \leq 2 \end{cases}$
 Discontinuity of g at $x = \{1, 2\}$

Topic 7

- | | | | |
|---------------|------------------|---------------|---------------|
| 1. (b) | 2. (a) | 3. (b) | 4. (c) |
| 5. (b) | 6. (a) | 7. (a) | 8. (a) |
| 9. (c) | 10. (a) | 11. (b) | 12. (d) |
| 13. (b) | 14. (c) | 15. (b) | 16. (a) |
| 17. (d) | 18. (d) | 19. (a) | 20. (d) |
| 21. (c) | 22. (d) | 23. (a) | 24. (a) |
| 25. (d) | 26. (a, b, d) | 27. (b, c, d) | 28. (b, c) |
| 29. (a, b, d) | 30. (b, c, d) | 31. (b, c) | |
| 32. (a, b) | 33. (b, c) | 34. (a, d) | 35. (b, c) |
| 36. (b, c) | 37. (a, b, c, d) | 38. (b, c) | 39. (a, d) |
| 40. (a, c, d) | 41. (a, b) | 42. (b, d) | 43. (a, b, d) |

202 Limit, Continuity and Differentiability

44. (b)
 45. (A) \rightarrow p, q, r, s; (B) \rightarrow p, s; (C) \rightarrow r, s; (D) \rightarrow p, s
 46. (A) \rightarrow p; (B) \rightarrow r 47. (24)
 48. $f'(0^+) = 0, f'(0^-) = 1$
 49. $x = 0$ 50. True 51. ($a = 1$) 52. $\left(1 - \frac{2}{\pi}\right)$
 54. (1, 2) 55. (i) Yes (ii) No
 56. (-1) 57. e^{2x} 58. {0, 1, 2} 60. $f'(0) = 0$
 61. $g(x)$ is differentiable for all $x \in (-2, 2) - \{0, 1\}$
 62. $g(x)$ is continuous for all $x \in (0, 2) - \{1\}$ and $g(x)$ is differentiable for all $x \in (0, 2) - \{1\}$
 63. $\left(-\frac{2}{9}\right)$ 64. $\left(\frac{1}{2} + \frac{\pi}{4}\right)$ 65. (4)
 66. (2) 67. (3) 68. $p(2) = 0$

Topic 8

1. (b) 2. (b) 3. (d) 4. (b)
 5. (d) 6. (b) 7. (b) 8. (b)

9. (c) 10. (b) 11. (a) 12. (d)
 13. (a) 14. (a) 15. (d) 16. (b)
 17. (c) 18. (a) 19. (b) 20. (d)
 21. (c) 22. 1 23. $x \in R - \{0\}$ 24. 1
 25. -4 26. $\frac{1}{e}$ 27. 0
 28. $\frac{-2(x^2 - x - 1)}{(x^2 + 1)^2} \cdot \sin^2\left(\frac{2x-1}{x^2+1}\right)$
 30. $\frac{3}{\pi\sqrt{\pi^2-3}}$
 33. $\frac{-8}{\log e^2} + \frac{32}{16 + \pi^2}$ 34. (11)
 36. $e^{x \sin x^3} (3x^3 \cos x^3 + \sin x^3) + (\tan x)^x [2x \operatorname{cosec} 2x + \log(\tan x)]$
 37. $\begin{cases} \frac{5}{3(1-x)^2} - 2\sin(4x+2), x < 1 \\ \frac{-5}{3(x-1)^2} - 2\sin(4x+2), x > 1 \end{cases}$
 38. (7)

Hints & Solutions

Topic 1 $\frac{0}{0}$ and $\frac{\infty}{\infty}$ Form

1. Let

$$P = \lim_{x \rightarrow 0} \frac{x + 2 \sin x}{\sqrt{x^2 + 2 \sin x + 1} - \sqrt{\sin^2 x - x + 1}} \quad \left[\frac{0}{0} \text{ form} \right]$$

On rationalization, we get

$$\begin{aligned} P &= \lim_{x \rightarrow 0} \frac{(x + 2 \sin x)}{x^2 + 2 \sin x + 1 - \sin^2 x + x - 1} \\ &\quad \times \frac{(\sqrt{x^2 + 2 \sin x + 1} + \sqrt{\sin^2 x - x + 1})}{(\sqrt{x^2 + 2 \sin x + 1} + \sqrt{\sin^2 x - x + 1})} \\ &= \lim_{x \rightarrow 0} \frac{(\sqrt{x^2 + 2 \sin x + 1} + \sqrt{\sin^2 x - x + 1})}{x^2 - \sin^2 x + 2 \sin x + x} \\ &\quad \times \lim_{x \rightarrow 0} \frac{x + 2 \sin x}{x^2 - \sin^2 x + 2 \sin x + x} \\ &= 2 \times \lim_{x \rightarrow 0} \frac{x + 2 \sin x}{x^2 - \sin^2 x + 2 \sin x + x} \quad \left[\frac{0}{0} \text{ form} \right] \end{aligned}$$

Now applying the L' Hopital's rule, we get

$$\begin{aligned} P &= 2 \times \lim_{x \rightarrow 0} \frac{1 + 2 \cos x}{2x - \sin 2x + 2 \cos x + 1} \\ &= 2 \frac{(1+2)}{0-0+2+1} \quad [\text{on applying limit}] \\ &= 2 \times \frac{3}{3} = 2 \\ &\Rightarrow \lim_{x \rightarrow 0} \frac{x + 2 \sin x}{\sqrt{x^2 + 2 \sin x + 1} - \sqrt{\sin^2 x - x + 1}} = 2 \end{aligned}$$

2. It is given that $\lim_{x \rightarrow 1} \frac{x^2 - ax + b}{x - 1} = 5$... (i)

Since, limit exist and equal to 5 and denominator is zero at $x = 1$, so numerator $x^2 - ax + b$ should be zero at $x = 1$,

$$\text{So } 1 - a + b = 0 \Rightarrow a = 1 + b \quad \dots(\text{ii})$$

On putting the value of 'a' from Eq. (ii) in Eq. (i), we get

$$\begin{aligned} \lim_{x \rightarrow 1} \frac{x^2 - (1+b)x + b}{x-1} = 5 &\Rightarrow \lim_{x \rightarrow 1} \frac{(x^2 - x) - b(x-1)}{x-1} = 5 \\ \Rightarrow \lim_{x \rightarrow 1} \frac{(x-1)(x-b)}{x-1} = 5 &\Rightarrow \lim_{x \rightarrow 1} (x-b) = 5 \\ \Rightarrow 1 - b = 5 &\Rightarrow b = -4 \quad \dots(\text{iii}) \end{aligned}$$

On putting value of 'b' from Eq. (iii) to Eq. (ii), we get $a = -3 \Rightarrow a + b = -7$

3. Given,

$$\begin{aligned} \lim_{x \rightarrow 1} \frac{x^4 - 1}{x - 1} &= \lim_{x \rightarrow k} \frac{x^3 - k^3}{x^2 - k^2} \Rightarrow \lim_{x \rightarrow 1} \frac{(x-1)(x+1)(x^2+1)}{x-1} \\ &= \lim_{x \rightarrow k} \frac{(x-k)(x^2+k^2+xk)}{(x-k)(x+k)} \Rightarrow 2 \times 2 = \frac{3k^2}{2k} \Rightarrow k = \frac{8}{3} \end{aligned}$$

4. Given limit is $\lim_{x \rightarrow 0} \frac{\sin^2 x}{\sqrt{2} - \sqrt{1 + \cos x}}$ $\left[\frac{0}{0} \text{ form} \right]$

$$\begin{aligned} &= \lim_{x \rightarrow 0} \frac{\sin^2 x}{\sqrt{2} - \sqrt{2} \cos \frac{x}{2}} \quad \left[\because 1 + \cos x = 2 \cos^2 \frac{x}{2} \right] \\ &= \lim_{x \rightarrow 0} \frac{\sin^2 x}{\sqrt{2} \left(1 - \cos \frac{x}{2}\right)} \end{aligned}$$

$$\begin{aligned}
 &= \lim_{x \rightarrow 0} \frac{\sin^2 x}{\sqrt{2} \times 2 \sin^2\left(\frac{x}{4}\right)} \quad \left[\because 1 - \cos \frac{x}{2} = 2 \sin^2 \frac{x}{4} \right] \\
 &= \lim_{x \rightarrow 0} \frac{x^2}{2\sqrt{2}\left(\frac{x}{4}\right)^2} = \frac{16}{2\sqrt{2}} = 4\sqrt{2} \quad \left[\lim_{x \rightarrow 0} \sin x = \lim_{x \rightarrow 0} x \right]
 \end{aligned}$$

5. Given, limit = $\lim_{x \rightarrow \pi/4} \frac{\cot^3 x - \tan x}{\cos\left(x + \frac{\pi}{4}\right)}$

$$\begin{aligned}
 &= \lim_{x \rightarrow \pi/4} \frac{1 - \tan^4 x}{\frac{1}{\sqrt{2}}(\cos x - \sin x)} \times \frac{1}{\tan^3 x} \quad \left[\because \cot x = \frac{1}{\tan x} \right] \\
 &= \lim_{x \rightarrow \pi/4} \frac{(1 - \tan^2 x)}{\cos x - \sin x} \times \frac{\sqrt{2}(1 + \tan^2 x)}{\tan^3 x} \\
 &= \lim_{x \rightarrow \pi/4} \frac{\cos^2 x - \sin^2 x}{\cos x - \sin x} \times \frac{\sqrt{2}(\sec^2 x)}{\cos^2 x \tan^3 x} \quad \left[\because 1 + \tan^2 x = \sec^2 x \right] \\
 &= \lim_{x \rightarrow \pi/4} \frac{(\cos x + \sin x)(\cos x - \sin x)}{(\cos x - \sin x)} \times \frac{\sqrt{2} \sec^4 x}{\tan^3 x} \\
 & \quad \left[\because (a^2 - b^2) = (a - b)(a + b) \right] \\
 &= \lim_{x \rightarrow \pi/4} \frac{\sqrt{2} \sec^4 x}{\tan^3 x} (\cos x + \sin x) \\
 &= \frac{\sqrt{2} (\sqrt{2})^4}{(1)^3} \left(\frac{1}{\sqrt{2}} + \frac{1}{\sqrt{2}} \right) \quad \text{[on applying limit]} \\
 &= 4\sqrt{2} \left(\frac{2}{\sqrt{2}} \right) = 8.
 \end{aligned}$$

6. $\lim_{x \rightarrow 0} \frac{x \cot 4x}{\sin^2 x \cot^2 2x} = \lim_{x \rightarrow 0} \frac{x}{\tan 4x} \cdot \frac{1}{\sin^2 x} \cdot \frac{\tan^2 2x}{1}$

$$\begin{aligned}
 &= \lim_{x \rightarrow 0} \frac{1}{4} \frac{4x}{(\tan 4x)} \cdot \frac{x^2}{\sin^2 x} \cdot \frac{\tan^2 2x}{x^2} \\
 &= \lim_{x \rightarrow 0} \frac{1}{4} \frac{4x}{(\tan 4x)} \left(\frac{x}{\sin x} \right)^2 \cdot \left(\frac{\tan 2x}{2x} \right)^2 \cdot \frac{4}{1} \\
 &= \frac{1}{4} \cdot 1 \cdot 1 \cdot \frac{4}{1} = 1 \quad \left[\because \lim_{x \rightarrow 0} \frac{x}{\sin x} = 1 = \lim_{x \rightarrow 0} \frac{\tan x}{x} \right]
 \end{aligned}$$

7. Clearly, $\lim_{y \rightarrow 0} \frac{\sqrt{1 + \sqrt{1 + y^4}} - \sqrt{2}}{y^4}$

$$\begin{aligned}
 &= \lim_{y \rightarrow 0} \frac{\sqrt{1 + \sqrt{1 + y^4}} - \sqrt{2}}{y^4} \times \frac{\sqrt{1 + \sqrt{1 + y^4}} + \sqrt{2}}{\sqrt{1 + \sqrt{1 + y^4}} + \sqrt{2}} \\
 & \quad \text{[rationalising the numerator]} \\
 &= \lim_{y \rightarrow 0} \frac{(1 + \sqrt{1 + y^4}) - 2}{y^4 (\sqrt{1 + \sqrt{1 + y^4}} + \sqrt{2})} \quad \left[\because (a + b)(a - b) = a^2 - b^2 \right] \\
 &= \lim_{y \rightarrow 0} \frac{\sqrt{1 + y^4} - 1}{y^4 (\sqrt{1 + \sqrt{1 + y^4}} + \sqrt{2})} \times \frac{\sqrt{1 + y^4} + 1}{\sqrt{1 + y^4} + 1} \\
 & \quad \text{[again, rationalising the numerator]}
 \end{aligned}$$

$$\begin{aligned}
 &= \lim_{y \rightarrow 0} \frac{y^4}{y^4 (\sqrt{1 + \sqrt{1 + y^4}} + \sqrt{2}) (\sqrt{1 + y^4} + 1)} = \frac{1}{2\sqrt{2} \times 2} \\
 & \quad \text{(by cancelling } y^4 \text{ and then by direct substitution).} \\
 &= \frac{1}{4\sqrt{2}}.
 \end{aligned}$$

8. $\lim_{x \rightarrow \pi/2} \frac{\cot x - \cos x}{(\pi - 2x)^3} = \lim_{x \rightarrow \pi/2} \frac{1}{8} \cdot \frac{\cos x(1 - \sin x)}{\sin x \left(\frac{\pi}{2} - x\right)^3}$

$$\begin{aligned}
 &= \lim_{h \rightarrow 0} \frac{1}{8} \cdot \frac{\cos\left(\frac{\pi}{2} - h\right) \left[1 - \sin\left(\frac{\pi}{2} - h\right)\right]}{\sin\left(\frac{\pi}{2} - h\right) \left(\frac{\pi}{2} - \frac{\pi}{2} + h\right)^3} \\
 &= \frac{1}{8} \lim_{h \rightarrow 0} \frac{\sin h (1 - \cos h)}{\cos h \cdot h^3} \\
 &= \frac{1}{8} \lim_{h \rightarrow 0} \frac{\sin h \left(2 \sin^2 \frac{h}{2}\right)}{\cos h \cdot h^3} = \frac{1}{4} \lim_{h \rightarrow 0} \frac{\sin h \cdot \sin^2\left(\frac{h}{2}\right)}{h^3 \cos h} \\
 &= \frac{1}{4} \lim_{h \rightarrow 0} \left(\frac{\sin h}{h} \right) \left(\frac{\sin \frac{h}{2}}{\frac{h}{2}} \right)^2 \cdot \frac{1}{\cos h} \cdot \frac{1}{4} = \frac{1}{4} \times \frac{1}{4} = \frac{1}{16}
 \end{aligned}$$

9. $\lim_{x \rightarrow 0} \frac{\sin(\pi \cos^2 x)}{x^2} = \lim_{x \rightarrow 0} \frac{\sin \pi(1 - \sin^2 x)}{x^2}$

$$\begin{aligned}
 &= \lim_{x \rightarrow 0} \frac{\sin(\pi - \pi \sin^2 x)}{x^2} \\
 &= \lim_{x \rightarrow 0} \frac{\sin(\pi \sin^2 x)}{x^2} \quad \left[\because \sin(\pi - \theta) = \sin \theta \right] \\
 &= \lim_{x \rightarrow 0} \frac{\sin \pi \sin^2 x}{\pi \sin^2 x} \times (\pi) \left(\frac{\sin^2 x}{x^2} \right) = \pi \left[\because \lim_{\theta \rightarrow 0} \frac{\sin \theta}{\theta} = 1 \right]
 \end{aligned}$$

10. We have, $\lim_{x \rightarrow 0} \frac{(1 - \cos 2x)(3 + \cos x)}{x \tan 4x} = \lim_{x \rightarrow 0} \frac{2 \sin^2 x (3 + \cos x)}{x \times \frac{\tan 4x}{4x} \times 4x}$

$$\begin{aligned}
 &= \lim_{x \rightarrow 0} \frac{2 \sin^2 x}{x^2} \times \lim_{x \rightarrow 0} \frac{(3 + \cos x)}{4} \times \frac{1}{\lim_{x \rightarrow 0} \frac{\tan 4x}{4x}} \\
 &= 2 \times \frac{4}{4} \times 1 \quad \left[\because \lim_{\theta \rightarrow 0} \frac{\sin \theta}{\theta} = 1 \text{ and } \lim_{\theta \rightarrow 0} \frac{\tan \theta}{\theta} = 1 \right] \\
 &= 2
 \end{aligned}$$

11. **PLAN** $\left(\frac{\infty}{\infty}\right)$ form

$$\lim_{x \rightarrow \infty} \frac{a_0 x^n + a_1 x^{n-1} + \dots + a_n}{b_0 x^m + b_1 x^{m-1} + \dots + b_m} = \begin{cases} 0, & \text{if } n < m \\ a_0, & \text{if } n = m \\ +\infty, & \text{if } n > m \text{ and } a_0 b_0 > 0 \\ -\infty, & \text{if } n > m \text{ and } a_0 b_0 < 0 \end{cases}$$

Description of Situation As to make degree of numerator equal to degree of denominator.

$$\therefore \lim_{x \rightarrow \infty} \left(\frac{x^2 + x + 1}{x + 1} - ax - b \right) = 4$$

204 Limit, Continuity and Differentiability

$$\Rightarrow \lim_{x \rightarrow \infty} \frac{x^2 + x + 1 - ax^2 - ax - bx - b}{x + 1} = 4$$

$$\Rightarrow \lim_{x \rightarrow \infty} \frac{x^2(1-a) + x(1-a-b) + (1-b)}{x+1} = 4$$

Here, we make degree of numerator
= degree of denominator

$$\therefore 1-a=0 \Rightarrow a=1$$

$$\text{and } \lim_{x \rightarrow \infty} \frac{x(1-a-b) + (1-b)}{x+1} = 4$$

$$\Rightarrow 1-a-b=4$$

$$\Rightarrow b=-4 \quad [\because (1-a)=0]$$

12. Here, $\lim_{h \rightarrow 0} \frac{f(2h+2+h^2) - f(2)}{f(h-h^2+1) - f(1)}$

[$\because f'(2)=6$ and $f'(1)=4$, given]

Applying L'Hospital's rule,

$$\begin{aligned} &= \lim_{h \rightarrow 0} \frac{\{f'(2h+2+h^2)\} \cdot (2+2h) - 0}{\{f'(h-h^2+1)\} \cdot (1-2h) - 0} = \frac{f'(2) \cdot 2}{f'(1) \cdot 1} \\ &= \frac{6 \cdot 2}{4 \cdot 1} = 3 \quad [\text{using } f'(2)=6 \text{ and } f'(1)=4] \end{aligned}$$

13. Given, $\lim_{x \rightarrow 0} \frac{\{(a-n)nx - \tan x\} \sin nx}{x^2} = 0$

$$\Rightarrow \lim_{x \rightarrow 0} \left\{ (a-n)n - \frac{\tan x}{x} \right\} \frac{\sin nx}{nx} \times n = 0$$

$$\Rightarrow \{(a-n)n - 1\}n = 0 \Rightarrow (a-n)n = 1 \Rightarrow a = n + \frac{1}{n}$$

14. $\lim_{x \rightarrow 0} \frac{(\cos x - 1)(\cos x - e^x)}{x^n}$

$$\begin{aligned} &= \lim_{x \rightarrow 0} \frac{\left(-2 \sin^2 \frac{x}{2}\right) \left\{ \left(1 - \frac{x^2}{2!} + \frac{x^4}{4!} - \dots\right) - \left(1 + x + \frac{x^2}{2!} + \frac{x^3}{3!} + \dots\right) \right\}}{x^n} \\ &= \lim_{x \rightarrow 0} \frac{\left(-2 \sin^2 \frac{x}{2}\right) \left(-x - \frac{2x^2}{2!} - \frac{x^3}{3!} - \dots\right)}{4 \left(\frac{x}{2}\right)^2 x^{n-2}} \\ &= \lim_{x \rightarrow 0} \frac{\sin^2 \frac{x}{2} \left(1 + x + \frac{x^2}{3!} + \dots\right)}{2 \left(\frac{x}{2}\right)^2 x^{n-3}} \end{aligned}$$

Above limit is finite, if $n-3=0$, i.e. $n=3$.

15. $\lim_{x \rightarrow 0} \frac{x \tan 2x - 2x \tan x}{(1 - \cos 2x)^2}$

NOTE In trigonometry try to make all trigonometric functions in same angle. It is called 3rd Golden rule of trigonometry.

$$= \lim_{x \rightarrow 0} \frac{x \frac{2 \tan x}{1 - \tan^2 x} - 2x \tan x}{(2 \sin^2 x)^2}$$

$$= \lim_{x \rightarrow 0} \frac{2x \tan x \left[\frac{1}{1 - \tan^2 x} - 1 \right]}{4 \sin^4 x}$$

$$= \lim_{x \rightarrow 0} \frac{2x \tan x \left[\frac{1 - 1 + \tan^2 x}{1 - \tan^2 x} \right]}{4 \sin^4 x}$$

$$= \lim_{x \rightarrow 0} \frac{2x \tan^3 x}{2 \sin^4 x (1 - \tan^2 x)} = \lim_{x \rightarrow 0} \frac{1}{2} \frac{x \left(\frac{\tan x}{x}\right)^3 \cdot x^3}{\sin^4 x (1 - \tan^2 x)}$$

$$= \frac{1}{2} \lim_{x \rightarrow 0} \frac{\left(\frac{\tan x}{x}\right)^3}{\left(\frac{\sin x}{x}\right)^4 (1 - \tan^2 x)} = \frac{1 \cdot (1)^3}{2(1)^4(1-0)} = \frac{1}{2}$$

16. LHL = $\lim_{x \rightarrow 1^-} \frac{\sqrt{1 - \cos 2(x-1)}}{x-1}$

$$= \lim_{x \rightarrow 1^-} \frac{\sqrt{2 \sin^2(x-1)}}{x-1} = \sqrt{2} \lim_{x \rightarrow 1^-} \frac{|\sin(x-1)|}{x-1}$$

Put $x=1-h$, $h>0$, for $x \rightarrow 1^-$, $h \rightarrow 0$

$$= \sqrt{2} \lim_{h \rightarrow 0} \frac{|\sin(-h)|}{-h} = \sqrt{2} \lim_{h \rightarrow 0} \frac{\sin h}{-h} = -\sqrt{2}$$

Again, RHL = $\lim_{x \rightarrow 1^+} \frac{\sqrt{1 - \cos 2(x-1)}}{x-1}$

$$= \lim_{x \rightarrow 1^+} \sqrt{2} \frac{|\sin(x-1)|}{x-1}$$

Put $x=1+h$, $h>0$

For $x \rightarrow 1^+$, $h \rightarrow 0$

$$= \lim_{h \rightarrow 0} \sqrt{2} \frac{|\sin h|}{h} = \lim_{h \rightarrow 0} \sqrt{2} \frac{\sin h}{h} = \sqrt{2}$$

\therefore LHL \neq RHL.

Hence, $\lim_{x \rightarrow 1} f(x)$ does not exist.

17. $\lim_{x \rightarrow 0} \frac{\sqrt{\frac{1}{2}(1 - \cos^2 x)}}{x} = \lim_{x \rightarrow 0} \frac{1}{\sqrt{2}} \cdot \frac{|\sin x|}{x}$

At $x=0$

$$\text{RHL} = \lim_{h \rightarrow 0} \frac{1}{\sqrt{2}} \cdot \frac{\sin h}{h} = \frac{1}{\sqrt{2}}$$

and $\text{LHL} = \lim_{h \rightarrow 0} \frac{1}{\sqrt{2}} \cdot \frac{\sin h}{-h} = -\frac{1}{\sqrt{2}}$

Here, RHL \neq LHL

\therefore Limit does not exist.

18. Since, $f(x) = \begin{cases} \frac{\sin [x]}{[x]}, & [x] \neq 0 \\ 0, & [x] = 0 \end{cases}$

$$\Rightarrow f(x) = \begin{cases} \frac{\sin [x]}{[x]}, & x \in \mathbb{R} - [0, 1) \\ 0, & 0 \leq x < 1 \end{cases}$$

At $x=0$,

$$\text{RHL} = \lim_{x \rightarrow 0^+} 0 = 0$$

and $\text{LHL} = \lim_{x \rightarrow 0^-} \frac{\sin [x]}{[x]} = \lim_{h \rightarrow 0} \frac{\sin [0-h]}{[0-h]}$
 $= \lim_{h \rightarrow 0} \frac{\sin (-1)}{-1} = \sin 1$

Since, $\text{RHL} \neq \text{LHL}$

\therefore Limit does not exist.

19. $\lim_{n \rightarrow \infty} \left(\frac{1}{1-n^2} + \frac{2}{1-n^2} + \dots + \frac{n}{1-n^2} \right)$
 $= \lim_{n \rightarrow \infty} \frac{1+2+3+\dots+n}{(1-n^2)} = \lim_{n \rightarrow \infty} \frac{n(n+1)}{2(1-n)(1+n)}$
 $\Rightarrow \lim_{n \rightarrow \infty} \frac{n}{2(1-n)} = -\frac{1}{2}$

20. Given, $f(a) = 2, f'(a) = 1, g(a) = -1, g'(a) = 2$

$\therefore \lim_{x \rightarrow a} \frac{g(x)f(a) - g(a)f(x)}{x-a}$
 $= \lim_{x \rightarrow a} \frac{g'(x)f(a) - g(a)f'(x)}{1-0}$, [using L' Hospital's rule]
 $= g'(a)f(a) - g(a)f'(a) = 2(2) - (-1)(1) = 5$

21. Given, $G(x) = -\sqrt{25-x^2}$
 $\therefore \lim_{x \rightarrow 1} \frac{G(x) - G(1)}{x-1} = \lim_{x \rightarrow 1} \frac{G'(x) - 0}{1-0}$ [using L' Hospital's rule]
 $= G'(1) = \frac{1}{\sqrt{24}}$
 $\left[\therefore G(x) = -\sqrt{25-x^2} \Rightarrow G'(x) = \frac{2x}{2\sqrt{25-x^2}} \right]$

22. We have,
 $f_n(x) = \sum_{j=1}^n \tan^{-1} \left(\frac{1}{1+(x+j)(x+j-1)} \right)$ for all $x \in (0, \infty)$
 $\Rightarrow f_n(x) = \sum_{j=1}^n \tan^{-1} \left(\frac{(x+j) - (x+j-1)}{1+(x+j)(x+j-1)} \right)$
 $\Rightarrow f_n(x) = \sum_{j=1}^n [\tan^{-1}(x+j) - \tan^{-1}(x+j-1)]$
 $\Rightarrow f_n(x) = (\tan^{-1}(x+1) - \tan^{-1}x)$
 $\quad + (\tan^{-1}(x+2) - \tan^{-1}(x+1))$
 $\quad + (\tan^{-1}(x+3) - \tan^{-1}(x+2))$
 $\quad + \dots + (\tan^{-1}(x+n) - \tan^{-1}(x+n-1))$
 $\Rightarrow f_n(x) = \tan^{-1}(x+n) - \tan^{-1}x$

This statement is false as $x \neq 0$ i.e., $x \in (0, \infty)$.

(b) This statement is also false as $0 \notin (0, \infty)$

(c) $f_n(x) = \tan^{-1}(x+n) - \tan^{-1}x$
 $\lim_{x \rightarrow \infty} \tan(f_n(x)) = \lim_{x \rightarrow \infty} \tan(\tan^{-1}(x+n) - \tan^{-1}x)$
 $\Rightarrow \lim_{x \rightarrow \infty} \tan(f_n(x)) = \lim_{x \rightarrow \infty} \tan \left(\tan^{-1} \frac{n}{1+nx+x^2} \right)$
 $= \lim_{x \rightarrow \infty} \frac{n}{1+nx+x^2} = 0$

\therefore (c) statement is false.

(d) $\lim_{x \rightarrow \infty} \sec^2(f_n(x)) = \lim_{x \rightarrow \infty} (1 + \tan^2 f_n(x))$
 $= 1 + \lim_{x \rightarrow \infty} \tan^2(f_n(x)) = 1 + 0 = 1$

\therefore (d) statement is true.

23. $L = \lim_{x \rightarrow 0} \frac{a - \sqrt{a^2 - x^2} - \frac{x^2}{4}}{x^4}, a > 0$
 $= \lim_{x \rightarrow 0} \frac{a - a \cdot \left[1 - \frac{1}{2} \cdot \frac{x^2}{a^2} + \frac{1}{2} \left(\frac{1}{2} - 1 \right) \cdot \frac{x^4}{a^4} - \dots \right] - \frac{x^2}{4}}{x^4}$
 $= \lim_{x \rightarrow 0} \frac{\frac{x^2}{2a} + \frac{1}{8} \cdot \frac{x^4}{a^3} + \dots - \frac{x^2}{4}}{x^4}$

Since, L is finite

$\Rightarrow 2a = 4 \Rightarrow a = 2$
 $\therefore L = \lim_{x \rightarrow 0} \frac{1}{8 \cdot a^3} = \frac{1}{64}$

24. $\lim_{h \rightarrow 0} \frac{\log(1+2h) - 2 \log(1+h)}{h^2}$ [0 form]

Applying L'Hospital's rule, we get

$\frac{2}{1+2h} - \frac{2}{1+h}$
 $= \lim_{h \rightarrow 0} \frac{2h}{(1+2h)(1+h)}$
 $= \lim_{h \rightarrow 0} \frac{2+2h-2-4h}{2h(1+2h)(1+h)}$
 $= \lim_{h \rightarrow 0} \frac{-1}{(1+2h)(1+h)} = -1$

25. Given, $f(x) = \begin{cases} \sin x, & x \neq n\pi, \quad n = 0, \pm 1, \pm 2, \dots \\ 2, & \text{otherwise} \end{cases}$
 $g[f(x)] = \begin{cases} \{f(x)\}^2 + 1, & f(x) \neq 0, 2 \\ 4, & f(x) = 0 \\ 5, & f(x) = 2 \end{cases}$
 $\therefore g[f(x)] = \begin{cases} (\sin^2 x) + 1, & x \neq n\pi = 0, \pm 1, \dots \\ 5, & x = n\pi \end{cases}$

Now, $\lim_{x \rightarrow 0} g[f(x)] = \lim_{x \rightarrow 0} (\sin^2 x) + 1 = 1$

26. Given, $P = 2(\sqrt{2hr - h^2} + \sqrt{2hr})$

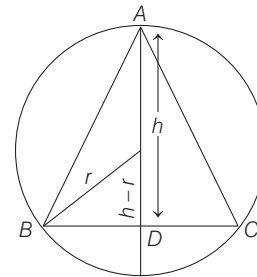

Here, $BD = \sqrt{r^2 - (h-r)^2} = \sqrt{2hr - h^2}$

$\therefore A = \frac{1}{2} \cdot 2BD \cdot h = (\sqrt{2hr - h^2}) h$

206 Limit, Continuity and Differentiability

$$\begin{aligned} \therefore \lim_{h \rightarrow 0} \frac{A}{P^3} &= \lim_{h \rightarrow 0} \frac{h \sqrt{2hr - h^2}}{8(\sqrt{2hr - h^2} + \sqrt{2hr})^3} \\ &= \lim_{h \rightarrow 0} \frac{h^{3/2} (\sqrt{2r - h})}{8 h^{3/2} (\sqrt{2r - h} + \sqrt{2r})^3} \\ &= \frac{1}{8} \cdot \frac{\sqrt{2r}}{(\sqrt{2r} + \sqrt{2r})^3} = \frac{1}{128 r} \end{aligned}$$

27. $\lim_{x \rightarrow -\infty} \left(\frac{x^4 \sin \frac{1}{x} + x^2}{1 + |x|^3} \right) = \lim_{x \rightarrow -\infty} \frac{x^4 \sin \frac{1}{x} + x^2}{1 - x^3}$

On dividing by x^3 , we get

$$\lim_{x \rightarrow -\infty} \frac{\frac{\sin(1/x) + 1/x}{1/x}}{\frac{1}{x^3} - 1} = \frac{1+0}{0-1} = -1$$

28. $f(x) = \begin{cases} \frac{x^3 + x^2 - 16x + 20}{(x-2)^2} & , \text{if } x \neq 2 \\ k & , \text{if } x = 2 \end{cases}$

Since, continuous at $x = 2$.

$$\begin{aligned} \Rightarrow f(2) &= \lim_{x \rightarrow 2} \frac{x^3 + x^2 - 16x + 20}{(x-2)^2}, [\text{using L'Hospital's rule}] \\ &= \lim_{x \rightarrow 2} \frac{3x^2 + 2x - 16}{2(x-2)} = \lim_{x \rightarrow 2} \frac{6x + 2}{2} = 7 \end{aligned}$$

$\therefore k = 7$

29. $\lim_{x \rightarrow 1} (1-x) \tan \frac{\pi x}{2}$

Put $x - 1 = y$

$$\therefore -\lim_{y \rightarrow 0} y \tan \frac{\pi}{2} (y+1) = -\lim_{y \rightarrow 0} y \left[-\cot \left(\frac{\pi}{2} y \right) \right]$$

$$= \lim_{y \rightarrow 0} \left(\frac{y \frac{\pi}{2}}{\tan \frac{\pi}{2} y} \right) \cdot \frac{2}{\pi} = \frac{2}{\pi}$$

30. If $\lim_{x \rightarrow a} [f(x)g(x)]$ exists, then both $\lim_{x \rightarrow a} f(x)$ and $\lim_{x \rightarrow a} g(x)$ may or may not exist. Hence, it is a false statement.

31. $\lim_{x \rightarrow 0} \frac{2^x - 1}{\sqrt{1+x} - 1} \times \frac{\sqrt{1+x} + 1}{\sqrt{1+x} + 1}$

$$\begin{aligned} &= \lim_{x \rightarrow 0} \frac{(2^x - 1)(\sqrt{1+x} + 1)}{x} \\ &= \log_e(2) \cdot (2) = 2 \log_e 2 = \log_e 4 \end{aligned}$$

32. Here, $\lim_{h \rightarrow 0} \frac{(a+h)^2 \sin(a+h) - a^2 \sin a}{h}$

$$\begin{aligned} &= \lim_{h \rightarrow 0} \frac{a^2 [\sin(a+h) - \sin a]}{h} \\ &\quad + \frac{h [2a \sin(a+h) + h \sin(a+h)]}{h} \end{aligned}$$

$$\begin{aligned} &= \lim_{h \rightarrow 0} \frac{a^2 \cdot 2 \cos \left(a + \frac{h}{2} \right) \cdot \sin \frac{h}{2}}{2 \cdot \frac{h}{2}} + (2a+h) \sin(a+h) \\ &= a^2 \cos a + 2a \sin a \end{aligned}$$

33. $\lim_{x \rightarrow 0} \sqrt{\frac{x - \sin x}{x + \cos^2 x}} = \frac{\lim_{x \rightarrow 0} (x - \sin x)^{1/2}}{\lim_{x \rightarrow 0} (x + \cos^2 x)^{1/2}}$

$$= \frac{\lim_{x \rightarrow 0} \left[x \left(1 - \frac{\sin x}{x} \right) \right]^{1/2}}{\lim_{x \rightarrow 0} (0+1)^{1/2}} = \frac{0 \cdot 0}{1} = 0$$

34. $\lim_{x \rightarrow 1} \left\{ \frac{x-1}{(x-1)(2x-5)} \right\} = \lim_{x \rightarrow 1} \frac{1}{2x-5} = -\frac{1}{3}$

35. Here, $\lim_{x \rightarrow 0} \frac{x^2 \sin(\beta x)}{\alpha x - \sin x} = 1$

$$\Rightarrow \lim_{x \rightarrow 0} \frac{x^2 \left(\beta x - \frac{(\beta x)^3}{3!} + \frac{(\beta x)^5}{5!} - \dots \right)}{\alpha x - \left(x - \frac{x^3}{3!} + \frac{x^5}{5!} - \dots \right)} = 1$$

$$\Rightarrow \lim_{x \rightarrow 0} \frac{x^3 \left(\beta - \frac{\beta^3 x^2}{3!} + \frac{\beta^5 x^4}{5!} - \dots \right)}{(\alpha - 1)x + \frac{x^3}{3!} + \frac{x^5}{5!} - \dots} = 1$$

Limit exists only, when $\alpha - 1 = 0$

$\Rightarrow \alpha = 1$... (i)

$$\therefore \lim_{x \rightarrow 0} \frac{x^3 \left(\beta - \frac{\beta^3 x^2}{3!} + \frac{\beta^5 x^4}{5!} - \dots \right)}{x^3 \left(\frac{1}{3!} - \frac{x^2}{5!} - \dots \right)} = 1$$

$\Rightarrow 6\beta = 1$... (ii)

From Eqs. (i) and (ii), we get

$$6(\alpha + \beta) = 6\alpha + 6\beta = 6 + 1 = 7$$

36. Given, $\lim_{\alpha \rightarrow 0} \left[\frac{e^{\cos(\alpha^n)} - e}{\alpha^m} \right] = -\frac{e}{2}$

$$\Rightarrow \lim_{\alpha \rightarrow 0} \frac{e \{ e^{\cos(\alpha^n) - 1} - 1 \} \cdot \cos(\alpha^n) - 1}{\alpha^m} = -\frac{e}{2}$$

$$\Rightarrow \lim_{\alpha \rightarrow 0} e \left\{ \frac{e^{\cos(\alpha^n) - 1} - 1}{\cos(\alpha^n) - 1} \right\} \cdot \lim_{\alpha \rightarrow 0} \frac{-2 \sin^2 \frac{\alpha^n}{2}}{\alpha^m} = -e/2$$

$$\Rightarrow e \times 1 \times (-2) \lim_{\alpha \rightarrow 0} \frac{\sin^2 \left(\frac{\alpha^n}{2} \right) \cdot \alpha^{2n}}{\alpha^{2n} \cdot 4\alpha^m} = -\frac{e}{2}$$

$$\Rightarrow e \times 1 \times -2 \times 1 \times \lim_{\alpha \rightarrow 0} \frac{\alpha^{2n-m}}{4} = -\frac{e}{2}$$

For this to be exists, $2n - m = 0$

$\Rightarrow \frac{m}{n} = 2$

Topic 2 1^∞ Form, RHL and LHL

1. Let $l = \lim_{x \rightarrow 0} \left(\frac{1 + f(3+x) - f(3)}{1 + f(2-x) - f(2)} \right)^{\frac{1}{x}}$ [1^∞ form]

$$\Rightarrow l = e^{\lim_{x \rightarrow 0} \frac{1 - 1 + f(3+x) - f(3)}{1 + f(2-x) - f(2)}}$$

$$= e^{\lim_{x \rightarrow 0} \left[\frac{1 + f(2-x) - f(2) - 1 - f(3+x) + f(3)}{x(1 + f(2-x) - f(2))} \right]}$$

$$= e^{\lim_{x \rightarrow 0} \left[\frac{f(2-x) - f(3+x) + f(3) - f(2)}{x(1 + f(2-x) - f(2))} \right]}$$

On applying L'Hopital rule, we get

$$l = e^{\lim_{x \rightarrow 0} \left[\frac{-f'(2-x) - f'(3+x)}{1 - xf'(2-x) + f(2-x) - f(2)} \right]}$$

On applying limit, we get

$$l = e^{\left(\frac{-f'(2) - f'(3)}{1 - 0 + f(2) - f(2)} \right)} = e^0 = 1$$

So, $\lim_{x \rightarrow 0} \left(\frac{1 + f(3+x) - f(3)}{1 + f(2-x) - f(2)} \right)^{\frac{1}{x}} = 1$

2. Let $L = \lim_{x \rightarrow 1^-} \frac{\sqrt{\pi} - \sqrt{2\sin^{-1}x}}{\sqrt{1-x}}$, then

$$L = \lim_{x \rightarrow 1^-} \frac{\sqrt{\pi} - \sqrt{2\sin^{-1}x}}{\sqrt{1-x}} \times \frac{\sqrt{\pi} + \sqrt{2\sin^{-1}x}}{\sqrt{\pi} + \sqrt{2\sin^{-1}x}}$$

[on rationalization]

$$= \lim_{x \rightarrow 1^-} \frac{\pi - 2\sin^{-1}x}{\sqrt{1-x}} \times \frac{1}{\sqrt{\pi} + \sqrt{2\sin^{-1}x}}$$

$$= \lim_{x \rightarrow 1^-} \frac{\pi - 2\left(\frac{\pi}{2} - \cos^{-1}x\right)}{\sqrt{1-x}} \times \frac{1}{\sqrt{\pi} + \sqrt{2\sin^{-1}x}}$$

$$\left[\because \sin^{-1}x + \cos^{-1}x = \frac{\pi}{2} \right]$$

$$= \lim_{x \rightarrow 1^-} \frac{2\cos^{-1}x}{\sqrt{1-x}} \times \lim_{x \rightarrow 1^-} \frac{1}{\sqrt{\pi} + \sqrt{2\sin^{-1}x}}$$

$$= \frac{1}{2\sqrt{\pi}} \lim_{x \rightarrow 1^-} \frac{2\cos^{-1}x}{\sqrt{1-x}} \left[\because \lim_{x \rightarrow 1^-} \sin^{-1}x = \frac{\pi}{2} \right]$$

Put $x = \cos\theta$, then as $x \rightarrow 1^-$, therefore $\theta \rightarrow 0^+$

Now, $L = \frac{1}{2\sqrt{\pi}} \lim_{\theta \rightarrow 0^+} \frac{2\theta}{\sqrt{1-\cos\theta}}$

$$= \frac{1}{2\sqrt{\pi}} \lim_{\theta \rightarrow 0^+} \frac{2\theta}{\sqrt{2\sin^2\left(\frac{\theta}{2}\right)}} \left[\because 1 - \cos\theta = 2\sin^2\frac{\theta}{2} \right]$$

$$= \frac{1}{2\sqrt{\pi}} \cdot \sqrt{2} \lim_{\theta \rightarrow 0^+} \frac{2 \cdot \left(\frac{\theta}{2}\right)}{\sin\left(\frac{\theta}{2}\right)}$$

$$= \frac{1}{2\sqrt{\pi}} 2\sqrt{2} = \frac{\sqrt{2}}{\sqrt{\pi}} \left[\because \lim_{x \rightarrow 0^+} \frac{\theta}{\sin\theta} = 1 \right]$$

3. **Key Idea** $\lim_{x \rightarrow a} f(x)$ exist iff

$$\lim_{x \rightarrow a^+} f(x) = \lim_{x \rightarrow a^-} f(x)$$

At $x = 0$,

$$\text{RHL} = \lim_{x \rightarrow 0^+} \frac{\tan(\pi \sin^2 x) + (|x| - \sin(x[x]))^2}{x^2}$$

$$= \lim_{x \rightarrow 0^+} \frac{\tan(\pi \sin^2 x) + (x - \sin(x \cdot 0))^2}{x^2} \left[\begin{array}{l} \because |x| = x \text{ for } x > 0 \\ \text{and } [x] = 0 \text{ for } 0 < x < 1 \end{array} \right]$$

$$= \lim_{x \rightarrow 0^+} \frac{\tan(\pi \sin^2 x) + x^2}{x^2}$$

$$= \lim_{x \rightarrow 0^+} \left(\frac{\tan(\pi \sin^2 x)}{\pi \sin^2 x} \cdot \frac{\pi \sin^2 x}{x^2} + 1 \right)$$

$$= \pi \lim_{x \rightarrow 0^+} \frac{\tan(\pi \sin^2 x)}{\pi \sin^2 x} \cdot \lim_{x \rightarrow 0^+} \frac{\sin^2 x}{x^2} + 1$$

$$= \pi + 1 \left[\begin{array}{l} \because \lim_{x \rightarrow 0} \frac{\tan x}{x} = 1 \\ \text{and } \lim_{x \rightarrow 0} \frac{\sin x}{x} = 1 \end{array} \right]$$

and LHL

$$= \lim_{x \rightarrow 0^-} \frac{\tan(\pi \sin^2 x) + (|x| - \sin(x[x]))^2}{x^2}$$

$$= \lim_{x \rightarrow 0^-} \frac{\tan(\pi \sin^2 x) + (-x - \sin(x(-1)))^2}{x^2} \left[\begin{array}{l} \because |x| = -x \text{ for } x < 0 \\ \text{and } [x] = -1 \text{ for } -1 < x < 0 \end{array} \right]$$

$$= \lim_{x \rightarrow 0^-} \frac{\tan(\pi \sin^2 x) + (x + \sin(-x))^2}{x^2}$$

$$= \lim_{x \rightarrow 0^-} \frac{\tan(\pi \sin^2 x) + (x - \sin x)^2}{x^2} \left[\because \sin(-\theta) = -\sin\theta \right]$$

$$= \lim_{x \rightarrow 0^-} \left(\frac{\tan(\pi \sin^2 x) + x^2 + \sin^2 x - 2x\sin x}{x^2} \right)$$

$$= \lim_{x \rightarrow 0^-} \left(\frac{\tan(\pi \sin^2 x)}{x^2} + 1 + \frac{\sin^2 x}{x^2} - \frac{2x\sin x}{x^2} \right)$$

$$= \lim_{x \rightarrow 0^-} \left(\frac{\tan(\pi \sin^2 x)}{\pi \sin^2 x} \cdot \frac{\pi \sin^2 x}{x^2} + 1 + \frac{\sin^2 x}{x^2} - 2 \frac{\sin x}{x} \right)$$

$$= \lim_{x \rightarrow 0^-} \frac{\tan(\pi \sin^2 x)}{\pi \sin^2 x} \cdot \lim_{x \rightarrow 0^-} \frac{\pi \sin^2 x}{x^2} + 1 + \lim_{x \rightarrow 0^-} \frac{\sin^2 x}{x^2} - 2 \lim_{x \rightarrow 0^-} \frac{\sin x}{x}$$

$$= \pi + 1 + 1 - 2 = \pi$$

\therefore RHL \neq LHL

\therefore Limit does not exist

208 Limit, Continuity and Differentiability

4. Given,

$$\lim_{x \rightarrow 1^+} \frac{(1 - |x| + \sin |1 - x|) \sin\left(\frac{\pi}{2} [1 - x]\right)}{|1 - x| [1 - x]}$$

Put $x = 1 + h$, then

$$x \rightarrow 1^+ \Rightarrow h \rightarrow 0^+$$

$$\therefore \lim_{x \rightarrow 1^+} \frac{(1 - |x| + \sin |1 - x|) \sin\left(\frac{\pi}{2} [1 - x]\right)}{|1 - x| [1 - x]}$$

$$= \lim_{h \rightarrow 0^+} \frac{(1 - |h + 1| + \sin |-h|) \sin\left(\frac{\pi}{2} [-h]\right)}{|-h| [-h]}$$

$$= \lim_{h \rightarrow 0^+} \frac{(1 - (h + 1) + \sin h) \sin\left(\frac{\pi}{2} [-h]\right)}{h [-h]}$$

$$(\because |-h| = h \text{ and } |h + 1| = h + 1 \text{ as } h > 0)$$

$$= \lim_{h \rightarrow 0^+} \frac{(-h + \sin h) \sin\left(\frac{\pi}{2} (-1)\right)}{h (-1)}$$

$$(\because [x] = -1 \text{ for } -1 < x < 0 \text{ and } h \rightarrow 0^+ \Rightarrow -h \rightarrow 0^-)$$

$$= \lim_{h \rightarrow 0^+} \frac{(-h + \sin h) \sin\left(\frac{-\pi}{2}\right)}{-h}$$

$$= \lim_{h \rightarrow 0^+} \left(\frac{\sin h}{h}\right) - \lim_{h \rightarrow 0^+} \left(\frac{h}{h}\right)$$

$$= \lim_{h \rightarrow 0^+} \left(\frac{\sin h}{h}\right) - \lim_{h \rightarrow 0^+} \left(\frac{h}{h}\right) = 1 - 1 = 0 \left[\because \lim_{h \rightarrow 0^+} \frac{\sin h}{h} = 1 \right]$$

5. $\lim_{x \rightarrow 0^-} \frac{x([x] + |x|) \sin [x]}{|x|} = \lim_{x \rightarrow 0^-} \frac{x([x] - x) \sin [x]}{-x}$

$$(\because |x| = -x, \text{ if } x < 0)$$

$$= \lim_{x \rightarrow 0^-} \frac{x(-1 - x) \sin(-1)}{-x} \quad (\because \lim_{x \rightarrow 0^-} [x] = -1)$$

$$= \lim_{x \rightarrow 0^-} \frac{-x(x + 1) \sin(-1)}{-x} = \lim_{x \rightarrow 0^-} (x + 1) \sin(-1)$$

$$= (0 + 1) \sin(-1) \text{ (by direct substitution)}$$

$$= -\sin 1 \quad (\because \sin(-\theta) = -\sin \theta)$$

6. **Key Idea** Use property of greatest integer function $[x] = x - \{x\}$.

$$\lim_{x \rightarrow 0^+} x \left(\left[\frac{1}{x} \right] + \left[\frac{2}{x} \right] + \dots + \left[\frac{15}{x} \right] \right)$$

We know, $[x] = x - \{x\}$

$$\therefore \left[\frac{1}{x} \right] = \frac{1}{x} - \left\{ \frac{1}{x} \right\}$$

Similarly, $\left[\frac{n}{x} \right] = \frac{n}{x} - \left\{ \frac{n}{x} \right\}$

$$\therefore \text{Given limit} = \lim_{x \rightarrow 0^+} x \left(\frac{1}{x} - \left\{ \frac{1}{x} \right\} + \frac{2}{x} - \left\{ \frac{2}{x} \right\} + \dots + \frac{15}{x} - \left\{ \frac{15}{x} \right\} \right)$$

$$= \lim_{x \rightarrow 0^+} (1 + 2 + 3 + \dots + 15) - x \left(\left\{ \frac{1}{x} \right\} + \left\{ \frac{2}{x} \right\} + \dots + \left\{ \frac{15}{x} \right\} \right)$$

$$= 120 - 0 = 120 \quad \left[\begin{array}{l} \because 0 \leq \left\{ \frac{n}{x} \right\} < 1, \text{ therefore} \\ 0 \leq x \left\{ \frac{n}{x} \right\} < x \Rightarrow \lim_{x \rightarrow 0^+} x \left\{ \frac{n}{x} \right\} = 0 \end{array} \right]$$

7. $f(x) = \frac{1 - x(1 + |1 - x|)}{|1 - x|} \cos\left(\frac{1}{1 - x}\right)$

Now, $\lim_{x \rightarrow 1^-} f(x) = \lim_{x \rightarrow 1^-} \frac{1 - x(1 + 1 - x)}{1 - x} \cos\left(\frac{1}{1 - x}\right)$

$$= \lim_{x \rightarrow 1^-} (1 - x) \cos\left(\frac{1}{1 - x}\right) = 0$$

and $\lim_{x \rightarrow 1^+} f(x) = \lim_{x \rightarrow 1^+} \frac{1 - x(1 - 1 + x)}{x - 1} \cos\left(\frac{1}{1 - x}\right)$

$$= \lim_{x \rightarrow 1^+} -(x + 1) \cdot \cos\left(\frac{1}{x + 1}\right), \text{ which does not exist.}$$

8. Given, $p = \lim_{x \rightarrow 0^+} (1 + \tan^2 \sqrt{x})^{\frac{1}{2x}}$ (1^∞ form)

$$= e^{\lim_{x \rightarrow 0^+} \frac{\tan^2 \sqrt{x}}{2x}} = e^{\frac{1}{2} \lim_{x \rightarrow 0^+} \left(\frac{\tan \sqrt{x}}{\sqrt{x}}\right)^2} = e^{\frac{1}{2}}$$

$$\therefore \log p = \log e^{\frac{1}{2}} = \frac{1}{2}$$

9. **PLAN** To make the quadratic into simple form we should eliminate radical sign.

Description of Situation As for given equation, when $a \rightarrow 0$ the equation reduces to identity in x .

$$\text{i.e. } ax^2 + bx + c = 0, \forall x \in R \text{ or } a = b = c \rightarrow 0$$

Thus, first we should make above equation independent from coefficients as 0.

Let $a + 1 = t^6$. Thus, when $a \rightarrow 0$, $t \rightarrow 1$.

$$\therefore (t^2 - 1)x^2 + (t^3 - 1)x + (t - 1) = 0$$

$$\Rightarrow (t - 1)\{(t + 1)x^2 + (t^2 + t + 1)x + 1\} = 0, \text{ as } t \rightarrow 1$$

$$2x^2 + 3x + 1 = 0$$

$$\Rightarrow 2x^2 + 2x + x + 1 = 0$$

$$\Rightarrow (2x + 1)(x + 1) = 0$$

Thus, $x = -1, -1/2$

or $\lim_{a \rightarrow 0^+} \alpha(a) = -1/2$

and $\lim_{a \rightarrow 0^+} \beta(a) = -1$

10. Here, $\lim_{x \rightarrow 0} \{1 + x \log(1 + b^2)\}^{1/x}$ [1[∞] form]
 $= e^{\lim_{x \rightarrow 0} \{x \log(1 + b^2)\} \cdot \frac{1}{x}}$
 $= e^{\log(1 + b^2)} = (1 + b^2)$... (i)

Given, $\lim_{x \rightarrow 0} \{1 + x \log(1 + b^2)\}^{1/x} = 2b \sin^2 \theta$
 $\Rightarrow (1 + b^2) = 2b \sin^2 \theta$
 $\therefore \sin^2 \theta = \frac{1 + b^2}{2b}$... (ii)

By AM ≥ GM, $\frac{b + \frac{1}{b}}{2} \geq \left(b \cdot \frac{1}{b}\right)^{1/2}$
 $\Rightarrow \frac{b^2 + 1}{2b} \geq 1$... (iii)

From Eqs. (ii) and (iii),
 $\sin^2 \theta = 1$
 $\Rightarrow \theta = \pm \frac{\pi}{2}$, as $\theta \in (-\pi, \pi]$

11. Here, $\lim_{x \rightarrow 0} (\sin x)^{1/x} + \lim_{x \rightarrow 0} \left(\frac{1}{x}\right)^{\sin x}$
 $= 0 + \lim_{x \rightarrow 0} e^{\log\left(\frac{1}{x}\right)^{\sin x}} = e^{\lim_{x \rightarrow 0} \frac{\log(1/x)}{\csc x}}$ $\left[\begin{array}{l} \lim_{x \rightarrow 0} (\sin x)^{1/x} \rightarrow 0 \\ \text{as, (decimal)}^\infty \rightarrow 0 \end{array} \right]$

Applying L'Hospital's rule, we get

$$\lim_{x \rightarrow 0} \frac{x \left(-\frac{1}{x^2}\right)}{-\csc x \cot x} = \lim_{x \rightarrow 0} \frac{\sin x}{x} \tan x = e^0 = 1$$

12. Let $y = \left[\frac{f(1+x)}{f(1)}\right]^{1/x}$
 $\Rightarrow \log y = \frac{1}{x} [\log f(1+x) - \log f(1)]$
 $\Rightarrow \lim_{x \rightarrow 0} \log y = \lim_{x \rightarrow 0} \left[\frac{1}{f(1+x)} \cdot f'(1+x)\right]$
[using L' Hospital's rule]
 $= \frac{f(1)}{f(1)} = \frac{6}{3}$

$\Rightarrow \log\left(\lim_{x \rightarrow 0} y\right) = 2$
 $\Rightarrow \lim_{x \rightarrow 0} y = e^2$

13. For $x \in R$, $\lim_{x \rightarrow \infty} \left(\frac{x-3}{x+2}\right)^x = \lim_{x \rightarrow \infty} \frac{(1-3/x)^x}{(1+2/x)^x} = \frac{e^{-3}}{e^2} = e^{-5}$

14. $\lim_{x \rightarrow 0} \left(\frac{1+5x^2}{1+3x^2}\right)^{1/x^2} = \frac{\lim_{x \rightarrow 0} [(1+5x^2)^{1/5x^2}]^5}{\lim_{x \rightarrow 0} [(1+3x^2)^{1/3x^2}]^3} = \frac{e^5}{e^3} = e^2$

15. $\lim_{x \rightarrow \infty} \left(\frac{x+6}{x+1}\right)^{x+4} = \lim_{x \rightarrow \infty} \left(1 + \frac{5}{x+1}\right)^{x+4}$ [1[∞] form]
 $= e^{\lim_{x \rightarrow \infty} \frac{5(x+4)}{x+1}} = e^5$

16. $\lim_{x \rightarrow 0} \left\{ \tan\left(\frac{\pi}{4} + x\right) \right\}^{1/x}$
 $= \lim_{x \rightarrow 0} \left\{ \frac{\tan \frac{\pi}{4} + \tan x}{1 - \tan \frac{\pi}{4} \tan x} \right\}^{1/x} = \lim_{x \rightarrow 0} \left\{ \frac{1 + \tan x}{1 - \tan x} \right\}^{1/x}$
 $= \lim_{x \rightarrow 0} \frac{[(1 + \tan x)^{1/\tan x}]^{\tan x/x}}{[(1 - \tan x)^{-1/\tan x}]^{-\tan x/x}} = \frac{e^1}{e^{-1}} = e^2$

17. The right hand limit

$$\begin{aligned} \lim_{x \rightarrow 0^+} \frac{(1-x)^{1/x} - e^{-1}}{x^a} &= \lim_{x \rightarrow 0^+} \frac{e^{\left\{\frac{1}{x} \log_e(1-x)\right\}} - e^{-1}}{x^a} \\ &= \lim_{x \rightarrow 0^+} \frac{e^{\frac{1}{x} \left(-x - \frac{x^2}{2} - \frac{x^3}{3} - \dots\right)} - e^{-1}}{x^a} \\ &= \lim_{x \rightarrow 0^+} \frac{e^{-1} \cdot e^{\left(-\frac{x}{2} - \frac{x^2}{3} - \frac{x^3}{4} - \dots\right)} - e^{-1}}{x^a} \\ &= e^{-1} \lim_{x \rightarrow 0^+} \frac{e^{\left(-\frac{x}{2} - \frac{x^2}{3} - \frac{x^3}{4} - \dots\right)} - 1}{x^a} \end{aligned}$$

The above limit will be non-zero, if $a = 1$. And at $a = 1$, the value of the limit is

$$= e^{-1} \left(-\frac{1}{2}\right) = -\frac{1}{2e}$$

18. **PLAN** $\lim_{x \rightarrow 0} \frac{\sin x}{x} = 1$

Given, $\lim_{x \rightarrow 1} \left\{ \frac{\sin(x-1) + a(1-x)}{(x-1) + \sin(x-1)} \right\}^{\frac{(1+\sqrt{x})(1-\sqrt{x})}{1-\sqrt{x}}} = \frac{1}{4}$

$$\lim_{x \rightarrow 1} \left\{ \frac{\sin(x-1) - a}{(x-1) + \sin(x-1)} \right\}^{1+\sqrt{x}} = \frac{1}{4}$$

$\Rightarrow \left(\frac{1-a}{2}\right)^2 = \frac{1}{4} \Rightarrow (a-1)^2 = 1$

$\Rightarrow a = 2$ or 0

Hence, the maximum value of a is 2.

Topic 3 Squeeze, Newton-Leibnitz's Theorem and Limit Based on Coverting infinite Series into Definite Integrals

1. Given α and β are roots of quadratic equation $375x^2 - 25x - 2 = 0$

$$\therefore \alpha + \beta = \frac{25}{375} = \frac{1}{15} \quad \dots (i)$$

$$\text{and } \alpha\beta = -\frac{2}{375} \quad \dots (ii)$$

$$\begin{aligned} \text{Now, } & \lim_{n \rightarrow \infty} \sum_{r=1}^n \alpha^r + \lim_{n \rightarrow \infty} \sum_{r=1}^n \beta^r \\ &= (\alpha + \alpha^2 + \alpha^3 + \dots + \text{upto infinite terms}) + \\ & \quad (\beta + \beta^2 + \beta^3 + \dots + \text{upto infinite terms}) \\ &= \frac{\alpha}{1-\alpha} + \frac{\beta}{1-\beta} \quad \left[\because S_{\infty} = \frac{a}{1-r} \text{ for GP} \right] \\ &= \frac{\alpha(1-\beta) + \beta(1-\alpha)}{(1-\alpha)(1-\beta)} \\ &= \frac{\alpha - \alpha\beta + \beta - \alpha\beta}{1-\alpha-\beta+\alpha\beta} \\ &= \frac{(\alpha + \beta) - 2\alpha\beta}{1 - (\alpha + \beta) + \alpha\beta} \end{aligned}$$

On substituting the value $\alpha + \beta = \frac{1}{15}$ and $\alpha\beta = -\frac{2}{375}$ from

Eqs. (i) and (ii) respectively, we get

$$= \frac{\frac{1}{15} + \frac{4}{375}}{1 - \frac{1}{15} - \frac{2}{375}} = \frac{29}{375 - 25 - 2} = \frac{29}{348} = \frac{1}{12}$$

2. $\lim_{x \rightarrow \frac{\pi}{4}} \frac{\int_{\sec^2 x}^2 f(t) dt}{x^2 - \frac{\pi^2}{4}}$ [0/0 form]

$$\begin{aligned} &= \lim_{x \rightarrow \pi/4} \frac{f(\sec^2 x) 2 \sec x \sec x \tan x}{2x} \quad \text{[using L' Hospital's rule]} \\ &= \frac{2f(2)}{\pi/4} = \frac{8}{\pi} f(2) \end{aligned}$$

3. Let $I = \lim_{n \rightarrow \infty} \frac{1}{n} \sum_{r=1}^{2n} \frac{r}{\sqrt{n^2 + r^2}} = \lim_{n \rightarrow \infty} \frac{1}{n} \sum_{r=1}^{2n} \frac{r}{n\sqrt{1 + (r/n)^2}}$

$$= \lim_{n \rightarrow \infty} \frac{1}{n} \sum_{r=1}^{2n} \frac{r/n}{\sqrt{1 + (r/n)^2}}$$

$$= \int_0^2 \frac{x}{\sqrt{1+x^2}} dx = [\sqrt{1+x^2}]_0^2 = \sqrt{5} - 1$$

4. Here,

$$f(x) = \lim_{n \rightarrow \infty} \left[\frac{n^n (x+n) \left(x + \frac{n}{2}\right) \dots \left(x + \frac{n}{n}\right)}{n! \left(x^2 + n^2\right) \left(x^2 + \frac{n^2}{4}\right) \dots \left(x^2 + \frac{n^2}{n^2}\right)} \right]^{\frac{x}{n}}, x > 0$$

Taking log on both sides, we get

$$\begin{aligned} \log_e \{f(x)\} &= \lim_{n \rightarrow \infty} \log \left[\frac{n^n (x+n) \left(x + \frac{n}{2}\right) \dots \left(x + \frac{n}{n}\right)}{n! \left(x^2 + n^2\right) \left(x^2 + \frac{n^2}{4}\right) \dots \left(x^2 + \frac{n^2}{n^2}\right)} \right]^{\frac{x}{n}} \\ &= \lim_{n \rightarrow \infty} \frac{x}{n} \cdot \log \left[\frac{\prod_{r=1}^n \left(x + \frac{1}{r/n}\right)}{\prod_{r=1}^n \left(x^2 + \frac{1}{(r/n)^2}\right) \prod_{r=1}^n (r/n)} \right] \\ &= x \lim_{n \rightarrow \infty} \frac{1}{n} \sum_{r=1}^n \log \left[\frac{x + \frac{1}{r/n}}{\left(x^2 + \frac{1}{(r/n)^2}\right) \frac{r}{n}} \right] \\ &= x \lim_{n \rightarrow \infty} \frac{1}{n} \sum_{r=1}^n \log \left(\frac{\frac{r}{n} \cdot x + 1}{\frac{r^2}{n^2} \cdot x^2 + 1} \right) \end{aligned}$$

Converting summation into definite integration, we get

$$\log_e \{f(x)\} = x \int_0^1 \log \left(\frac{xt + 1}{x^2 t^2 + 1} \right) dt$$

Put,

$$tx = z$$

\Rightarrow

$$xdt = dz$$

\therefore

$$\log_e \{f(x)\} = x \int_0^x \log \left(\frac{1+z}{1+z^2} \right) \frac{dz}{x}$$

\Rightarrow

$$\log_e \{f(x)\} = \int_0^x \log \left(\frac{1+z}{1+z^2} \right) dz$$

Using Newton-Leibnitz formula, we get

$$\frac{1}{f(x)} \cdot f'(x) = \log \left(\frac{1+x}{1+x^2} \right) \quad \dots (i)$$

Here, at $x = 1$,

$$\frac{f'(1)}{f(1)} = \log(1) = 0$$

\therefore

$$f'(1) = 0$$

Now, sign scheme of $f'(x)$ is shown below

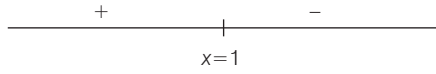

\therefore At $x = 1$, function attains maximum.

Since, $f(x)$ increases on $(0, 1)$.

$\therefore f(1) > f(1/2)$

\therefore Option (a) is incorrect.

$f(1/3) < f(2/3)$

\therefore Option (b) is correct.

Also, $f'(x) < 0$, when $x > 1$

$\Rightarrow f'(2) < 0$

\therefore Option (c) is correct.

Also, $\frac{f'(x)}{f(x)} = \log\left(\frac{1+x}{1+x^2}\right)$

$\therefore \frac{f'(3)}{f(3)} - \frac{f'(2)}{f(2)} = \log\left(\frac{4}{10}\right) - \log\left(\frac{3}{5}\right)$
 $= \log(2/3) < 0$

$\Rightarrow \frac{f'(3)}{f(3)} < \frac{f'(2)}{f(2)}$

\therefore Option (d) is incorrect.

5. We have,

$y_n = \frac{1}{n} [(n+1)(n+2)\dots(n+n)]^{1/n}$

and $\lim_{n \rightarrow \infty} y_n = L$

$\Rightarrow L = \lim_{n \rightarrow \infty} \frac{1}{n} [(n+1)(n+2)(n+3)\dots(n+n)]^{1/n}$

$\Rightarrow L = \lim_{n \rightarrow \infty} \left[\left(1 + \frac{1}{n}\right) \left(1 + \frac{2}{n}\right) \left(1 + \frac{3}{n}\right) \dots \left(1 + \frac{n}{n}\right) \right]^{1/n}$

$\Rightarrow \log L = \lim_{n \rightarrow \infty} \frac{1}{n} \left[\log\left(1 + \frac{1}{n}\right) + \log\left(1 + \frac{2}{n}\right) + \dots + \log\left(1 + \frac{n}{n}\right) \right]$

$\Rightarrow \log L = \lim_{n \rightarrow \infty} \frac{1}{n} \sum_{r=1}^n \log\left(1 + \frac{r}{n}\right)$

$\Rightarrow \log L = \int_0^1 \frac{1}{x} \times \log(1+x) dx$

$\Rightarrow \log L = (x \cdot \log(1+x))_0^1 - \int_0^1 \left[\frac{d}{dx} (\log(1+x)) \int dx \right] dx$
 [by using integration by parts]

$\Rightarrow \log L = [x \log(1+x)]_0^1 - \int_0^1 \frac{x}{1+x} dx$

$\Rightarrow \log L = \log 2 - \int_0^1 \left(\frac{x+1}{x+1} - \frac{1}{x+1} \right) dx$

$\Rightarrow \log L = \log 2 - [x]_0^1 + [\log(x+1)]_0^1$

$\Rightarrow \log L = \log 2 - 1 + \log 2 - 0$

$\Rightarrow \log L = \log 4 - \log e = \log \frac{4}{e} \Rightarrow L = \frac{4}{e} \Rightarrow$

$[L] = \left[\frac{4}{e} \right] = 1$

6. $\lim_{x \rightarrow 0} \frac{\int_0^{x^2} \cos^2 t dt}{x \sin x} \quad \left[\frac{0}{0} \text{ form} \right]$

Applying L'Hospital's rule, we get

$= \lim_{x \rightarrow 0} \frac{\cos^2(x^2) \cdot 2x - 0}{x \cos x + \sin x} = \lim_{x \rightarrow 0} \frac{2 \cdot \cos^2(x^2)}{\cos x + \frac{\sin x}{x}} = \frac{2}{1+1} = 1$

Topic 4 Continuity at a Point

1. Given function is

$f(x) = \begin{cases} \sqrt{2} \cos x - 1 & , x \neq \frac{\pi}{4} \\ k & , x = \frac{\pi}{4} \end{cases}$

\therefore Function $f(x)$ is continuous, so it is continuous at $x = \frac{\pi}{4}$.

$\therefore f\left(\frac{\pi}{4}\right) = \lim_{x \rightarrow \frac{\pi}{4}} f(x)$

$\Rightarrow k = \lim_{x \rightarrow \frac{\pi}{4}} \frac{\sqrt{2} \cos x - 1}{\cot x - 1}$

Put $x = \frac{\pi}{4} + h$, when $x \rightarrow \frac{\pi}{4}$, then $h \rightarrow 0$

$k = \lim_{h \rightarrow 0} \frac{\sqrt{2} \cos\left(\frac{\pi}{4} + h\right) - 1}{\cot\left(\frac{\pi}{4} + h\right) - 1}$

$= \lim_{h \rightarrow 0} \frac{\sqrt{2} \left[\frac{1}{\sqrt{2}} \cos h - \frac{1}{\sqrt{2}} \sin h \right] - 1}{\frac{\cot h - 1}{\cot h + 1} - 1}$

[$\because \cos(x+y) = \cos x \cos y - \sin x \sin y$ and $\cot(x+y) = \frac{\cot x \cot y - 1}{\cot y + \cot x}$]

$= \lim_{h \rightarrow 0} \frac{\cos h - \sin h - 1}{-2} \cdot \frac{1}{1 + \cot h}$

$= \lim_{h \rightarrow 0} \left[\frac{(1 - \cos h) + \sin h}{2 \sin h} (\sin h + \cos h) \right]$

$= \lim_{h \rightarrow 0} \left[\frac{2 \sin^2 \frac{h}{2} + 2 \sin \frac{h}{2} \cos \frac{h}{2}}{4 \sin \frac{h}{2} \cos \frac{h}{2}} (\sin h + \cos h) \right]$

$= \lim_{h \rightarrow 0} \left[\frac{\sin \frac{h}{2} + \cos \frac{h}{2}}{2 \cos \frac{h}{2}} \times (\sin h + \cos h) \right]$

$\Rightarrow k = \frac{1}{2}$

212 Limit, Continuity and Differentiability

2. **NOTE** All integers are critical point for greatest integer function.

Case I When $x \in I$

$$f(x) = [x]^2 - [x^2] = x^2 - x^2 = 0$$

Case II When $x \notin I$

If $0 < x < 1$, then $[x] = 0$

and $0 < x^2 < 1$, then $[x^2] = 0$

Next, if $1 \leq x^2 < 2 \Rightarrow 1 \leq x < \sqrt{2}$

$\Rightarrow [x] = 1$ and $[x^2] = 1$

Therefore, $f(x) = [x]^2 - [x^2] = 0$, if $1 \leq x < \sqrt{2}$

Therefore, $f(x) = 0$, if $0 \leq x < \sqrt{2}$

This shows that $f(x)$ is continuous at $x = 1$.

Therefore, $f(x)$ is discontinuous in $(-\infty, 0) \cup [\sqrt{2}, \infty)$ on many other points. Therefore, (b) is the answer.

3. Given, $f(x) = [\tan^2 x]$

Now, $-45^\circ < x < 45^\circ$

$\Rightarrow \tan(-45^\circ) < \tan x < \tan(45^\circ)$

$\Rightarrow -\tan 45^\circ < \tan x < \tan 45^\circ$

$\Rightarrow -1 < \tan x < 1$

$\Rightarrow 0 < \tan^2 x < 1 \Rightarrow [\tan^2 x] = 0$

i.e. $f(x)$ is zero for all values of x from $x = -45^\circ$ to 45° .

Thus, $f(x)$ exists when $x \rightarrow 0$ and also it is continuous at $x = 0$. Also, $f(x)$ is differentiable at $x = 0$ and has a value of zero.

Therefore, (b) is the answer.

4. Here, $f(x) = [x] \cos\left(\frac{2x-1}{2}\right)\pi$

$$\therefore f(x) = \begin{cases} -\cos\left(\frac{2x-1}{2}\right)\pi & , -1 \leq x < 0 \\ 0 & , 0 \leq x < 1 \\ \cos\left(\frac{2x-1}{2}\right)\pi & , 1 \leq x < 2 \\ 2\cos\left(\frac{2x-1}{2}\right)\pi & , 2 \leq x < 3 \end{cases}$$

which shows RHL = LHL at $x = n \in \text{Integer}$ as if $x = 1$

$$\Rightarrow \lim_{x \rightarrow 1^+} \cos\left(\frac{2x-1}{2}\right)\pi = 0 \quad \text{and} \quad \lim_{x \rightarrow 1^-} 0 = 0$$

Also, $f(1) = 0$

\therefore Continuous at $x = 1$.

Similarly, when $x = 2$,

$$\lim_{x \rightarrow 2^+} f(x) = \lim_{x \rightarrow 2^-} f(x) = 0$$

Thus, function is discontinuous at no x .

Hence, option (c) is the correct answer.

5. Given, $f(x) = x(\sqrt{x} + \sqrt{x+1})$

$\Rightarrow f(x)$ would exist when $x \geq 0$ and $x+1 \geq 0$.

$\Rightarrow f(x)$ would exist when $x \geq 0$.

$\therefore f(x)$ is not continuous at $x = 0$,

because LHL does not exist.

Hence, option (c) is correct.

6. For $f(x)$ to be continuous, we must have

$$\begin{aligned} f(0) &= \lim_{x \rightarrow 0} f(x) \\ &= \lim_{x \rightarrow 0} \frac{\log(1+ax) - \log(1-bx)}{x} \\ &= \lim_{x \rightarrow 0} \frac{a \log(1+ax)}{ax} + \frac{b \log(1-bx)}{-bx} \\ &= a \cdot 1 + b \cdot 1 \quad \left[\text{using } \lim_{x \rightarrow 0} \frac{\log(1+x)}{x} = 1 \right] \\ &= a + b \end{aligned}$$

$$\therefore f(0) = (a + b)$$

7. $f(x) = x \cos(\pi(x + [x]))$

At $x = 0$

$$\lim_{x \rightarrow 0} f(x) = \lim_{x \rightarrow 0} x \cos(\pi(x + [x])) = 0$$

and $f(x) = 0$

\therefore It is continuous at $x = 0$ and clearly discontinuous at other integer points.

8. **PLAN** If a continuous function has values of opposite sign inside an interval, then it has a root in that interval.

$$f, g : [0, 1] \rightarrow R$$

We take two cases.

Case I Let f and g attain their common maximum value at p .

$$\Rightarrow f(p) = g(p),$$

where $p \in [0, 1]$

Case II Let f and g attain their common maximum value at different points.

$$\Rightarrow f(a) = M \text{ and } g(b) = M$$

$$\Rightarrow f(a) - g(a) > 0 \text{ and } f(b) - g(b) < 0$$

$\Rightarrow f(c) - g(c) = 0$ for some $c \in [0, 1]$ as f and g are continuous functions.

$$\Rightarrow f(c) - g(c) = 0 \text{ for some } c \in [0, 1] \text{ for all cases.} \quad \dots(i)$$

$$\text{Option (a)} \Rightarrow f^2(c) - g^2(c) + 3[f(c) - g(c)] = 0$$

which is true from Eq. (i).

$$\text{Option (d)} \Rightarrow f^2(c) - g^2(c) = 0 \text{ which is true from Eq. (i)}$$

Now, if we take $f(x) = 1$ and $g(x) = 1, \forall x \in [0, 1]$

Options (b) and (c) does not hold. Hence, options (a) and (d) are correct.

9. $f(2n) = a_n, f(2n^+) = a_n$

$$f(2n^-) = b_n + 1$$

$$\Rightarrow a_n - b_n = 1$$

$$f(2n+1) = a_n$$

$$f\{(2n+1)^-\} = a_n$$

$$f\{(2n+1)^+\} = b_{n+1} - 1$$

$$\Rightarrow a_n = b_{n+1} - 1 \text{ or } a_n - b_{n+1} = -1$$

$$\text{or } a_{n-1} - b_n = -1$$

10. Given, $x^2 + y^2 = 4 \Rightarrow y = \sqrt{4 - x^2}$

$$\text{or } f(x) = \sqrt{4 - x^2}$$

$$11. f(x) = \begin{cases} \{1 + |\sin x|\}^{a/|\sin x|}, & \pi/6 < x < 0 \\ b, & x = 0 \\ e^{\tan 2x/\tan 3x}, & 0 < x < \pi/6 \end{cases}$$

Since, $f(x)$ is continuous at $x = 0$.

$$\begin{aligned} \therefore \text{RHL (at } x=0) &= \text{LHL (at } x=0) = f(0) \\ \Rightarrow \lim_{h \rightarrow 0} e^{\tan 2h/\tan 3h} &= \lim_{h \rightarrow 0} \{1 + |\sin h|\}^{a/|\sin h|} = b \\ \Rightarrow e^{2/3} &= e^a = b \\ \therefore a &= 2/3 \\ \text{and } b &= e^{2/3} \end{aligned}$$

12. Since, $f(x)$ is continuous at $x = 0$.

$$\begin{aligned} \therefore f(0) &= \text{LHL} \\ \Rightarrow a &= \lim_{h \rightarrow 0} \frac{1 - \cos 4h}{h^2} \\ \Rightarrow a &= \lim_{h \rightarrow 0} \frac{2 \sin^2 2h}{h^2} \times \frac{4}{4} \\ \Rightarrow a &= 8 \end{aligned}$$

13. Since, $f(x)$ is continuous for $0 \leq x \leq \pi$

$$\begin{aligned} \therefore \text{RHL (at } x = \frac{\pi}{4}) &= \text{LHL (at } x = \frac{\pi}{4}) \\ \Rightarrow \left(2 \cdot \frac{\pi}{4} \cot \frac{\pi}{4} + b\right) &= \left(\frac{\pi}{4} + a\sqrt{2} \cdot \sin \frac{\pi}{4}\right) \\ \Rightarrow \frac{\pi}{2} + b = \frac{\pi}{4} + a &\Rightarrow a - b = \frac{\pi}{4} \quad \dots(i) \end{aligned}$$

$$\begin{aligned} \text{Also, RHL (at } x = \frac{\pi}{2}) &= \text{LHL (at } x = \frac{\pi}{2}) \\ \Rightarrow \left(a \cos \frac{2\pi}{2} - b \sin \frac{\pi}{2}\right) &= \left(2 \cdot \frac{\pi}{2} \cdot \cot \frac{\pi}{2} + b\right) \\ \Rightarrow -a - b &= b \\ \Rightarrow a + 2b &= 0 \quad \dots(ii) \end{aligned}$$

On solving Eqs. (i) and (ii), we get

$$a = \frac{\pi}{6} \text{ and } b = -\frac{\pi}{12}$$

14. Let $g(x) = ax + b$ be a polynomial of degree one.

$$\Rightarrow f(x) = \begin{cases} ax + b, & x \leq 0 \\ \left(\frac{1+x}{2+x}\right)^{1/x}, & x > 0 \end{cases}$$

Since, $f(x)$ is continuous and $f'(1) = f(-1)$

$$\begin{aligned} \therefore \text{(LHL at } x=0) &= \text{(RHL at } x=0) \\ \Rightarrow \lim_{x \rightarrow 0} (ax + b) &= \lim_{x \rightarrow 0} \left(\frac{x+1}{x+2}\right)^{1/x} \\ \Rightarrow b &= 0 \quad \dots(i) \\ \text{Also, } f'(1) &= f(-1) \end{aligned}$$

$$\begin{aligned} \Rightarrow f(x) &= \left(\frac{1+x}{2+x}\right)^{1/x}, x > 0 \\ \Rightarrow \log f(x) &= \frac{1}{x} [\log(1+x) - \log(2+x)] \end{aligned}$$

On differentiating both sides, we get

$$\begin{aligned} \frac{f'(x)}{f(x)} &= \frac{x \left[\frac{1}{1+x} - \frac{1}{2+x} \right] - 1 \left[\log \left(\frac{1+x}{2+x} \right) \right]}{x^2} \\ \therefore f'(x) &= \left(\frac{1+x}{2+x}\right)^{1/x} \left[\frac{x}{(1+x)(2+x)} - \frac{\log \left(\frac{1+x}{2+x} \right)}{x^2} \right] \end{aligned}$$

$$\Rightarrow f'(1) = \frac{2}{3} \left\{ \frac{1}{6} - \log \left(\frac{2}{3} \right) \right\}$$

and $f(-1) = -a + b = -a$ [from Eq. (i)]

$$\therefore -a = \frac{2}{3} \left(\frac{1}{6} - \log \left(\frac{2}{3} \right) \right)$$

$$\text{Thus, } f(x) = \begin{cases} \frac{2}{3} \left(\log \left(\frac{2}{3} \right) - \frac{1}{6} \right) x, & x \leq 0 \\ \left(\frac{1+x}{2+x}\right)^{1/x}, & x > 0 \end{cases}$$

Now, to check continuity of $f(x)$ (at $x = 0$).

$$\text{RHL} = \lim_{x \rightarrow 0} \left(\frac{1+x}{2+x}\right)^{1/x} = 0$$

$$\therefore \text{LHL} = \lim_{x \rightarrow 0} \frac{2}{3} \left[\log \left(\frac{2}{3} \right) - \frac{1}{6} \right] x = 0$$

Hence, $f(x)$ is continuous for all x .

$$15. \text{ Given, } f(x) = \begin{cases} \frac{\sin(a+1)x + \sin x}{x}, & x < 0 \\ c, & x = 0 \\ \frac{(x+bx^2)^{1/2} - x^{1/2}}{bx^{3/2}}, & x > 0 \end{cases}$$

is continuous at $x = 0$.

$$\Rightarrow \text{(LHL at } x=0) = \text{(RHL at } x=0) = f(0)$$

$$\begin{aligned} \Rightarrow \lim_{x \rightarrow 0} \left[\frac{\sin(a+1)x + \sin x}{x} \right] \\ = \lim_{x \rightarrow 0} \frac{(1+bx)^{1/2} - 1}{bx} = c \end{aligned}$$

$$\Rightarrow (a+1) + 1 = \lim_{x \rightarrow 0} \frac{bx}{bx} \cdot \frac{1}{\sqrt{1+bx} + 1} = c$$

$$\Rightarrow a + 2 = \frac{1}{2} = c$$

$$\therefore a = -\frac{3}{2}, c = \frac{1}{2}$$

and $b \in R$

214 Limit, Continuity and Differentiability

16. (i) Given, $f_1 : R \rightarrow R$ and $f_1(x) = \sin(\sqrt{1 - e^{-x^2}})$

$\therefore f_1(x)$ is continuous at $x = 0$

$$\text{Now, } f_1'(x) = \cos \sqrt{1 - e^{-x^2}} \cdot \frac{1}{2\sqrt{1 - e^{-x^2}}} (2xe^{-x^2})$$

At $x = 0$

$f_1'(x)$ does not exist.

$\therefore f_1(x)$ is not differential at $x = 0$

Hence, option (2) for P .

(ii) Given, $f_2(x) = \begin{cases} \frac{|\sin x|}{\tan^{-1} x}, & \text{if } x \neq 0 \\ 1, & \text{if } x = 0 \end{cases}$

$$\Rightarrow f_2(x) = \begin{cases} \frac{-\sin x}{\tan^{-1} x} & x < 0 \\ \frac{\sin x}{\tan^{-1} x} & x > 0 \\ 1 & x = 0 \end{cases}$$

Clearly, $f_2(x)$ is not continuous at $x = 0$.

\therefore Option (1) for Q .

(iii) Given, $f_3(x) = [\sin(\log_e(x+2))]$, where $[\]$ is G.I.F.

and $f_3 : (-1, e^{\pi/2} - 2) \rightarrow R$

$$\begin{aligned} \text{It is given } & -1 < x < e^{\pi/2} - 2 \\ \Rightarrow & -1 + 2 < x + 2 < e^{\pi/2} - 2 + 2 \\ \Rightarrow & 1 < x + 2 < e^{\pi/2} \\ \Rightarrow & \log_e 1 < \log_e(x+2) < \log_e e^{\pi/2} \\ \Rightarrow & 0 < \log_e(x+2) < \frac{\pi}{2} \\ \Rightarrow & \sin 0 < \sin \log_e(x+2) < \sin \frac{\pi}{2} \\ \Rightarrow & 0 < \sin \log_e(x+2) < 1 \end{aligned}$$

$$\therefore [\sin \log_e(x+2)] = 0$$

$$\therefore f_3(x) = 0, f_3'(x) = f_3''(x) = 0$$

It is differentiable and continuous at $x = 0$.

\therefore Option (4) for R

(iv) Given, $f_4(x) = \begin{cases} x^2 \sin\left(\frac{1}{x}\right), & \text{if } x \neq 0 \\ 0, & \text{if } x = 0 \end{cases}$

$$\text{Now, } \lim_{x \rightarrow 0} f_4(x) = \lim_{x \rightarrow 0} x^2 \sin\left(\frac{1}{x}\right) = 0$$

$$f_4'(x) = 2x \sin\left(\frac{1}{x}\right) - \cos\left(\frac{1}{x}\right)$$

$$\text{For } x = 0, f_4'(x) = \lim_{h \rightarrow 0} \frac{f(0+h) - f(0)}{h}$$

$$\Rightarrow f_4'(x) = \lim_{h \rightarrow 0} \frac{h^2 \sin\left(\frac{1}{h}\right) - 0}{h}$$

$$\Rightarrow f_4'(x) = \lim_{h \rightarrow 0} h \sin\left(\frac{1}{h}\right) = 0$$

$$\text{Thus, } f_4'(x) = \begin{cases} 2x \sin\left(\frac{1}{x}\right) - \cos\left(\frac{1}{x}\right), & x \neq 0 \\ 0, & x = 0 \end{cases}$$

$$\text{Again, } \lim_{x \rightarrow 0} f'(x) = \lim_{x \rightarrow 0} \left(2x \sin\left(\frac{1}{x}\right) - \cos\left(\frac{1}{x}\right)\right)$$

does not exist.

Since, $\lim_{x \rightarrow 0} \cos\left(\frac{1}{x}\right)$ does not exist.

Hence, $f'(x)$ is not continuous at $x = 0$.

\therefore Option (3) for S .

Topic 5 Continuity in a Domain

1. Given $\int_6^{f(x)} 4t^3 dt = (x-2)g(x)$

$$\Rightarrow g(x) = \frac{\int_6^{f(x)} 4t^3 dt}{(x-2)} \quad [\text{provided } x \neq 2]$$

$$\text{So, } \lim_{x \rightarrow 2} g(x) = \lim_{x \rightarrow 2} \frac{\int_6^{f(x)} 4t^3 dt}{x-2}$$

$$\left[\because \frac{0}{0} \text{ form as } x \rightarrow 2 \Rightarrow f(2) = 6 \right]$$

$$\lim_{x \rightarrow 2} g(x) = \lim_{x \rightarrow 2} \frac{4(f(x))^3 f'(x)}{1}$$

$$\left[\because \frac{d}{dx} \int_{\phi_1(x)}^{\phi_2(x)} f(t) dt = f(\phi_2(x)) \cdot \phi_2'(x) - f(\phi_1(x)) \cdot \phi_1'(x) \right]$$

On applying limit, we get

$$\lim_{x \rightarrow 2} g(x) = 4(f(2))^3 f'(2) = 4 \times (6)^3 \cdot \frac{1}{48} = \frac{4 \times 216}{48} = 18$$

$$\left[\because f(2) = 6 \text{ and } f'(2) = \frac{1}{48} \right]$$

2. Given function

$$f(x) = \begin{cases} \frac{\sin(p+1)x + \sin x}{x}, & x < 0 \\ q, & x = 0 \\ \frac{\sqrt{x+x^2} - \sqrt{x}}{x^{3/2}}, & x > 0 \end{cases}$$

is continuous at $x = 0$, then

$$f(0) = \lim_{x \rightarrow 0^-} f(x) = \lim_{x \rightarrow 0^+} f(x) \dots (i)$$

$$\lim_{x \rightarrow 0^-} f(x) = \lim_{x \rightarrow 0^-} \frac{\sin(p+1)x + \sin x}{x}$$

$$= p + 1 + 1 = p + 2 \quad \left[\because \lim_{x \rightarrow 0} \frac{\sin(ax)}{x} = a \right]$$

$$\text{and } \lim_{x \rightarrow 0^+} f(x) = \lim_{x \rightarrow 0^+} \frac{\sqrt{x+x^2} - \sqrt{x}}{x^{3/2}}$$

$$= \lim_{x \rightarrow 0^+} \frac{\sqrt{x}(1+x)^{1/2} - 1}{x\sqrt{x}}$$

$$\begin{aligned}
 &= \lim_{x \rightarrow 0^+} \left(\frac{1 + \frac{1}{2}x + \frac{\frac{1}{2}(1-1)}{2!}x^2 + \dots - 1}{x} \right) \\
 &= 1 + nx + \frac{n(n-1)}{1 \cdot 2}x^2 + \frac{n(n-1)(n-2)}{1 \cdot 2 \cdot 3}x^3 + \dots, |x| < 1 \quad [\because (1+x)^n] \\
 &= \lim_{x \rightarrow 0^+} \left(\frac{1}{2} + \frac{\frac{1}{2}(\frac{1}{2}-1)}{2!}x + \dots \right) = \frac{1}{2}
 \end{aligned}$$

From Eq. (i), we get

$$f(0) = q = \frac{1}{2} \text{ and } \lim_{x \rightarrow 0^-} f(x) = p + 2 = \frac{1}{2}$$

$$\Rightarrow p = -\frac{3}{2}$$

$$\text{So, } (p, q) = \left(-\frac{3}{2}, \frac{1}{2}\right)$$

3. Given function

$$f(x) = \begin{cases} a|\pi - x| + 1, & x \leq 5 \\ b|x - \pi| + 3, & x > 5 \end{cases}$$

and it is also given that $f(x)$ is continuous at $x = 5$.

$$\text{Clearly, } f(5) = a(5 - \pi) + 1 \quad \dots(i)$$

$$\lim_{x \rightarrow 5^-} f(x) = \lim_{h \rightarrow 0} [a|\pi - (5 - h)| + 1] = a(5 - \pi) + 1 \quad \dots(ii)$$

$$\text{and } \lim_{x \rightarrow 5^+} f(x) = \lim_{h \rightarrow 0} [b|(5 + h) - \pi| + 3] = b(5 - \pi) + 3 \quad \dots(iii)$$

\therefore Function $f(x)$ is continuous at $x = 5$.

$$\therefore f(5) = \lim_{x \rightarrow 5^+} f(x) = \lim_{x \rightarrow 5^-} f(x)$$

$$\Rightarrow a(5 - \pi) + 1 = b(5 - \pi) + 3$$

$$\Rightarrow (a - b)(5 - \pi) = 2$$

$$\Rightarrow a - b = \frac{2}{5 - \pi}$$

4. Given function $f(x) = [x] - \left[\frac{x}{4}\right], x \in R$

$$\text{Now, } \lim_{x \rightarrow 4^+} f(x) = \lim_{h \rightarrow 0} \left([4 + h] - \left[\frac{4 + h}{4}\right] \right)$$

$[\because \text{ put } x = 4 + h, \text{ when } x \rightarrow 4^+, \text{ then } h \rightarrow 0]$

$$= \lim_{h \rightarrow 0} (4 - 1) = 3$$

$$\text{and } \lim_{x \rightarrow 4^-} f(x) = \lim_{h \rightarrow 0} \left([4 - h] - \left[\frac{4 - h}{4}\right] \right)$$

$[\because \text{ put } x = 4 - h, \text{ when } x \rightarrow 4^- \text{ then } h \rightarrow 0]$

$$= \lim_{h \rightarrow 0} (3 - 0) = 3$$

$$\text{and } f(4) = [4] - \left[\frac{4}{4}\right] = 4 - 1 = 3$$

$$\therefore \lim_{x \rightarrow 4^-} f(x) = f(4) = \lim_{x \rightarrow 4^+} f(x) = 3$$

So, function $f(x)$ is continuous at $x = 4$.

5. Given function $f : [-1, 3] \rightarrow R$ is defined as

$$f(x) = \begin{cases} |x| + [x], & -1 \leq x < 1 \\ x + |x|, & 1 \leq x < 2 \\ x + [x], & 2 \leq x \leq 3 \end{cases} = \begin{cases} -x - 1, & -1 \leq x < 0 \\ x, & 0 \leq x < 1 \\ 2x, & 1 \leq x < 2 \\ x + 2, & 2 \leq x < 3 \\ 6, & x = 3 \end{cases}$$

$[\because \text{ if } n \leq x < n + 1, \forall n \in \text{Integer}, [x] = n]$

$$\therefore \lim_{x \rightarrow 0^-} f(x) = -1 \neq f(0) \quad [\because f(0) = 0]$$

$$\therefore \lim_{x \rightarrow 1^-} f(x) = 1 \neq f(1) \quad [\because f(1) = 2]$$

$$\therefore \lim_{x \rightarrow 2^-} f(x) = 4 = f(2) = \lim_{x \rightarrow 2^+} f(x) = 4 \quad [\because f(2) = 4]$$

$$\text{and } \lim_{x \rightarrow 3^-} f(x) = 5 \neq f(3) \quad [\because f(3) = 6]$$

\therefore Function $f(x)$ is discontinuous at points 0, 1 and 3.

6.

Key Idea A function is said to be continuous if it is continuous at each point of the domain.

We have,

$$f(x) = \begin{cases} 5 & \text{if } x \leq 1 \\ a + bx & \text{if } 1 < x < 3 \\ b + 5x & \text{if } 3 \leq x < 5 \\ 30 & \text{if } x \geq 5 \end{cases}$$

Clearly, for $f(x)$ to be continuous, it has to be continuous at $x = 1, x = 3$ and $x = 5$

$[\because \text{ In rest portion it is continuous everywhere}]$

$$\therefore \lim_{x \rightarrow 1^+} (a + bx) = a + b = 5 \quad \dots(i)$$

$$[\because \lim_{x \rightarrow 1^-} f(x) = \lim_{x \rightarrow 1^+} f(x) = f(1)]$$

$$\lim_{x \rightarrow 5^-} (b + 5x) = b + 25 = 30 \quad \dots(ii)$$

$$[\because \lim_{x \rightarrow 5^-} f(x) = \lim_{x \rightarrow 5^+} f(x) = f(5)]$$

On solving Eqs. (i) and (ii), we get $b = 5$ and $a = 0$

Now, let us check the continuity of $f(x)$ at $x = 3$.

$$\text{Here, } \lim_{x \rightarrow 3^-} (a + bx) = a + 3b = 15$$

$$\text{and } \lim_{x \rightarrow 3^+} (b + 5x) = b + 15 = 20$$

Hence, for $a = 0$ and $b = 5, f(x)$ is not continuous at $x = 3$

$\therefore f(x)$ cannot be continuous for any values of a and b .

7. Given, $f(x) = \frac{1}{2}x - 1$ for $0 \leq x \leq \pi$

$$\therefore [f(x)] = \begin{cases} -1, & 0 \leq x < 2 \\ 0, & 2 \leq x \leq \pi \end{cases}$$

$$\Rightarrow \tan [f(x)] = \begin{cases} \tan(-1), & 0 \leq x < 2 \\ \tan 0, & 2 \leq x \leq \pi \end{cases}$$

216 Limit, Continuity and Differentiability

$$\therefore \lim_{x \rightarrow 2^-} \tan [f(x)] = -\tan 1$$

$$\text{and } \lim_{x \rightarrow 2^+} \tan [f(x)] = 0$$

So, $\tan f(x)$ is not continuous at $x = 2$.

$$\text{Now, } f(x) = \frac{1}{2}x - 1 \Rightarrow f(x) = \frac{x-2}{2} \Rightarrow \frac{1}{f(x)} = \frac{2}{x-2}$$

Clearly, $1/f(x)$ is not continuous at $x = 2$.

So, $\tan [f(x)]$ and $\left[\frac{1}{f(x)}\right]$ are both discontinuous at $x = 2$.

8. The function $f(x) = \tan x$ is not defined at $x = \frac{\pi}{2}$, so $f(x)$ is not continuous on $(0, \pi)$.

(b) Since, $g(x) = x \sin \frac{1}{x}$ is continuous on $(0, \pi)$ and the integral function of a continuous function is continuous,

$$\therefore f(x) = \int_0^x t \left(\sin \frac{1}{t} \right) dt \text{ is continuous on } (0, \pi).$$

$$(c) \text{ Also, } f(x) = \begin{cases} 1, & 0 < x \leq \frac{3\pi}{4} \\ 2 \sin \left(\frac{2x}{9} \right), & \frac{3\pi}{4} < x < \pi \end{cases}$$

$$\text{We have, } \lim_{x \rightarrow \frac{3\pi}{4}^-} f(x) = 1$$

$$\lim_{x \rightarrow \frac{3\pi}{4}^+} f(x) = \lim_{x \rightarrow \frac{3\pi}{4}^+} 2 \sin \left(\frac{2x}{9} \right) = 1$$

So, $f(x)$ is continuous at $x = 3\pi/4$.

$\Rightarrow f(x)$ is continuous at all other points.

$$(d) \text{ Finally, } f(x) = \frac{\pi}{2} \sin(x + \pi) \Rightarrow f\left(\frac{\pi}{2}\right) = -\frac{\pi}{2}$$

$$\lim_{x \rightarrow \left(\frac{\pi}{2}\right)^-} f(x) = \lim_{h \rightarrow 0} f\left(\frac{\pi}{2} - h\right) = \lim_{h \rightarrow 0} \frac{\pi}{2} \sin\left(\frac{3\pi}{2} - h\right) = \frac{\pi}{2}$$

$$\text{and } \lim_{x \rightarrow \left(\pi/2\right)^+} f(x) = \lim_{h \rightarrow 0} f\left(\frac{\pi}{2} + h\right)$$

$$= \lim_{h \rightarrow 0} \frac{\pi}{2} \sin\left(\frac{3\pi}{2} + h\right) = \frac{\pi}{2}$$

So, $f(x)$ is not continuous at $x = \pi/2$.

9. We have, for $-1 < x < 1 \Rightarrow 0 \leq x \sin \pi x \leq 1/2$

$$\therefore [x \sin \pi x] = 0$$

Also, $x \sin \pi x$ becomes negative and numerically less than 1 when x is slightly greater than 1 and so by definition of $[x]$.

$$f(x) = [x \sin \pi x] = -1, \text{ when } 1 < x < 1 + h$$

Thus, $f(x)$ is constant and equal to 0 in the closed interval $[-1, 1]$ and so $f(x)$ is continuous and differentiable in the open interval $(-1, 1)$.

At $x = 1$, $f(x)$ is discontinuous, since $\lim_{h \rightarrow 0} (1 - h) = 0$

$$\text{and } \lim_{h \rightarrow 0} (1 + h) = -1$$

$\therefore f(x)$ is not differentiable at $x = 1$.

Hence, (a), (b) and (d) are correct answers.

$$10. f(x) = [x] \sin \left(\frac{\pi}{[x+1]} \right)$$

We know that, $[x]$ is continuous on $R \sim I$, where I denotes the set of integers and $\sin \left(\frac{\pi}{[x+1]} \right)$ is discontinuous for $[x+1] = 0$.

$$\Rightarrow 0 \leq x+1 < 1 \Rightarrow -1 \leq x < 0$$

Thus, the function is defined in the interval.

$$11. \text{ Given, } f(x) = \begin{cases} \frac{x^2}{2}, & 0 \leq x < 1 \\ 2x^2 - 3x + \frac{3}{2}, & 1 \leq x \leq 2 \end{cases} \quad \dots(i)$$

Clearly, RHL (at $x = 1$) = $1/2$ and LHL (at $x = 1$) = $1/2$

$$\text{Also, } f(x) = 1/2$$

$\therefore f(x)$ is continuous for all $x \in [0, 2]$.

On differentiating Eq. (i), we get

$$f'(x) = \begin{cases} x, & 0 \leq x < 1 \\ 4x - 3, & 1 \leq x \leq 2 \end{cases} \quad \dots(ii)$$

Clearly, RHL (at $x = 1$) for $f'(x) = 1$

and LHL (at $x = 1$) for $f'(x) = 1$

$$\text{Also, } f'(1) = 1$$

Thus, $f'(x)$ is continuous for all $x \in [0, 2]$.

Again, differentiating Eq. (ii), we get

$$f''(x) = \begin{cases} 1, & 0 \leq x < 1 \\ 4, & 1 \leq x \leq 2 \end{cases}$$

Clearly, RHL (at $x = 1$) \neq LHL (at $x = 1$)

Thus, $f''(x)$ is not continuous at $x = 1$.

or $f''(x)$ is continuous for all $x \in [0, 2] - \{1\}$.

12. The given function ' f ' defined on $\left(-\frac{1}{3}, \frac{1}{3}\right)$ by

$$f(x) = \begin{cases} \frac{1}{x} \log_e \left(\frac{1+3x}{1-2x} \right), & \text{where } x \neq 0 \\ k, & \text{where } x = 0 \end{cases}$$

is continuous, then

$$\begin{aligned} k &= \lim_{x \rightarrow 0} \frac{1}{x} \log_e \left(\frac{1+3x}{1-2x} \right) \\ &= \lim_{x \rightarrow 0} \left[\frac{\log_e(1+3x)}{x} - \frac{\log_e(1-2x)}{x} \right] \\ &= 3 - (-2) = 5 \Rightarrow k = 5 \end{aligned}$$

Topic 6 Continuity for Composition and Function

1. Given, $f(x) = x \cos \frac{1}{x}$, $x \geq 1 \Rightarrow f'(x) = \frac{1}{x} \sin \frac{1}{x} + \cos \frac{1}{x}$
- $$\Rightarrow f''(x) = -\frac{1}{x^3} \cos \left(\frac{1}{x} \right)$$

Now, $\lim_{x \rightarrow \infty} f'(x) = 0 + 1 = 1 \Rightarrow$ Option (b) is correct.

Now, $x \in [1, \infty) \Rightarrow \frac{1}{x} \in (0, 1] \Rightarrow f''(x) < 0$

Option (d) is correct.

As $f'(1) = \sin 1 + \cos 1 > 1$
 $f'(x)$ is strictly decreasing and $\lim_{x \rightarrow \infty} f'(x) = 1$

So, graph of $f'(x)$ is shown as below.

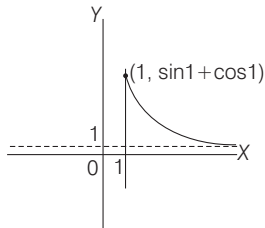

Now, in $[x, x+2]$, $x \in [1, \infty)$, $f(x)$ is continuous and differentiable so by LMVT,

$$f'(x) = \frac{f(x+2) - f(x)}{2}$$

As, $f'(x) > 1$

For all $x \in [1, \infty)$

$$\Rightarrow \frac{f(x+2) - f(x)}{2} > 1 \Rightarrow f(x+2) - f(x) > 2$$

For all $x \in [1, \infty)$

$$2. \text{ } g \circ f(x) = \begin{cases} f(x) + 1, & \text{if } f(x) < 0 \\ \{f(x) - 1\}^2 + b, & \text{if } f(x) \geq 0 \end{cases}$$

$$= \begin{cases} x + a + 1, & \text{if } x < -a \\ (x + a - 1)^2 + b, & \text{if } -a \leq x < 0 \\ (|x - 1| - 1)^2 + b, & \text{if } x \geq 0 \end{cases}$$

As $g \circ f(x)$ is continuous at $x = -a$

$$g \circ f(-a) = g \circ f(-a^+) = g \circ f(-a^-)$$

$$\Rightarrow 1 + b = 1 + b = 1 \Rightarrow b = 0$$

Also, $g \circ f(x)$ is continuous at $x = 0$

$$\Rightarrow g \circ f(0) = g \circ f(0^+) = g \circ f(0^-)$$

$$\Rightarrow b = b = (a - 1)^2 + b \Rightarrow a = 1$$

Hence, $g \circ f(x) = \begin{cases} x + 2, & \text{if } x < -1 \\ x^2, & \text{if } -1 \leq x < 0 \\ (|x - 1| - 1)^2, & \text{if } x \geq 0 \end{cases}$

In the neighbourhood of $x = 0$, $g \circ f(x) = x^2$, which is differentiable at $x = 0$.

3. As, $f(x)$ is continuous and $g(x)$ is discontinuous.

Case I $g(x)$ is discontinuous as limit does not exist at $x = k$.

$$\therefore \phi(x) = f(x) + g(x)$$

$$\Rightarrow \lim_{x \rightarrow k} \phi(x) = \lim_{x \rightarrow k} \{f(x) + g(x)\} = \text{does not exist.}$$

$\therefore \phi(x)$ is discontinuous.

Case II $g(x)$ is discontinuous as, $\lim_{x \rightarrow k} g(x) \neq g(k)$.

$$\therefore \phi(x) = f(x) + g(x).$$

$$\Rightarrow \lim_{x \rightarrow k} \phi(x) = \lim_{x \rightarrow k} \{f(x) + g(x)\} = \text{exists and is a finite quantity}$$

but $\phi(k) = f(k) + g(k) \neq \lim_{x \rightarrow k} \{f(x) + g(x)\}$

$\therefore \phi(x) = f(x) + g(x)$ is discontinuous, whenever $g(x)$ is discontinuous.

4. Given, $f(x) = \begin{cases} 1 + x, & 0 \leq x \leq 2 \\ 3 - x, & 2 < x \leq 3 \end{cases}$

$$\therefore f \circ f(x) = f[f(x)] = \begin{cases} 1 + f(x), & 0 \leq f(x) \leq 2 \\ 3 - f(x), & 2 < f(x) \leq 3 \end{cases}$$

$$\Rightarrow f \circ f = \begin{cases} 1 + f(x), & 0 \leq f(x) \leq 1 \\ 1 + f(x), & 1 < f(x) \leq 2 \\ 3 - f(x), & 2 < f(x) \leq 3 \end{cases} = \begin{cases} 1 + (3 - x), & 2 < x \leq 3 \\ 1 + (1 + x), & 0 \leq x \leq 1 \\ 3 - (1 + x), & 1 < x \leq 2 \end{cases}$$

$$\Rightarrow (f \circ f)(x) = \begin{cases} 4 - x, & 2 < x \leq 3 \\ 2 + x, & 0 \leq x \leq 1 \\ 2 - x, & 1 < x \leq 2 \end{cases}$$

Now, RHL (at $x = 2$) = 2 and LHL (at $x = 2$) = 0

Also, RHL (at $x = 1$) = 1 and LHL (at $x = 1$) = 3

Therefore, $f(x)$ is discontinuous at $x = 1, 2$

$\therefore f[f(x)]$ is discontinuous at $x = \{1, 2\}$.

5. Since, $f(x)$ is continuous at $x = 0$.

$$\Rightarrow \lim_{x \rightarrow 0} f(x) = f(0)$$

$$\Rightarrow f(0^+) = f(0^-) = f(0) = 0 \quad \dots(i)$$

To show, continuous at $x = k$

$$\text{RHL} = \lim_{h \rightarrow 0} f(k + h) = \lim_{h \rightarrow 0} [f(k) + f(h)] = f(k) + f(0^+)$$

$$= f(k) + f(0)$$

$$\text{LHL} = \lim_{h \rightarrow 0} f(k - h) = \lim_{h \rightarrow 0} [f(k) + f(-h)]$$

$$= f(k) + f(0^-) = f(k) + f(0)$$

$$\therefore \lim_{x \rightarrow k} f(x) = f(k)$$

$\Rightarrow f(x)$ is continuous for all $x \in R$.

Topic 7 Differentiability at a Point

1. Given function, $g(x) = |f(x)|$

where $f : R \rightarrow R$ be differentiable at $c \in R$ and $f(c) = 0$, then for function 'g' at $x = c$

$$g'(c) = \lim_{h \rightarrow 0} \frac{g(c+h) - g(c)}{h} \quad [\text{where } h > 0]$$

$$= \lim_{h \rightarrow 0} \frac{|f(c+h)| - |f(c)|}{h} = \lim_{h \rightarrow 0} \frac{|f(c+h)|}{h}$$

[as $f(c) = 0$ (given)]

$$= \lim_{h \rightarrow 0} \left| \frac{f(c+h) - f(c)}{h} \right| \quad [\because h > 0]$$

$$= \left| \lim_{h \rightarrow 0} \frac{f(c+h) - f(c)}{h} \right|$$

$$= |f'(c)| \quad [\because f \text{ is differentiable at } x = c]$$

Now, if $f'(c) = 0$, then $g(x)$ is differentiable at $x = c$, otherwise LHD (at $x = c$) and RHD (at $x = c$) is different.

2.

Key Idea (i) First use L' Hopital rule

(ii) Now, use formula

$$\frac{d}{dx} \int_{\phi_1(x)}^{\phi_2(x)} f(t) dt = f[\phi_2(x)] \cdot \phi_2'(x) - f[\phi_1(x)] \cdot \phi_1'(x)$$

218 Limit, Continuity and Differentiability

$$\text{Let } l = \lim_{x \rightarrow 2} \int_6^{f(x)} \frac{2tdt}{(x-2)} = \lim_{x \rightarrow 2} \frac{\int_6^{f(x)} 2tdt}{(x-2)} \left[\begin{array}{l} 0 \\ 0 \end{array} \text{ form, as } f(2) = 6 \right]$$

On applying the L' Hopital rule, we get

$$l = \lim_{x \rightarrow 2} \frac{2f(x)f'(x)}{1} \left[\because \frac{d}{dx} \int_{\phi_1(x)}^{\phi_2(x)} f(t)dt = f(\phi_2(x)) \cdot \phi_2'(x) - f(\phi_1(x)) \cdot \phi_1'(x) \right]$$

$$\text{So, } l = 2f(2) \cdot f'(2) = 12f'(2) \quad [\because f(2) = 6]$$

$$\therefore \lim_{x \rightarrow 2} \int_6^{f(x)} \frac{2tdt}{x-2} = 12f'(2)$$

3. Given function is $f(x) = 15 - |x - 10|$, $x \in \mathbf{R}$ and

$$\begin{aligned} g(x) &= f(f(x)) \\ &= f(15 - |x - 10|) = 15 - |15 - |x - 10| - 10| \\ &= 15 - |5 - |x - 10|| \\ &= \begin{cases} 15 - |5 - (x - 10)|, & x \geq 10 \\ 15 - |5 + (x - 10)|, & x < 10 \end{cases} \\ &= \begin{cases} 15 - |15 - x|, & x \geq 10 \\ 15 - |x - 5|, & x < 10 \end{cases} \\ &= \begin{cases} 15 + (x - 5) = 10 + x, & x < 5 \\ 15 - (x - 5) = 20 - x, & 5 \leq x < 10 \\ 15 + (x - 15) = x, & 10 \leq x < 15 \\ 15 - (x - 15) = 30 - x, & x \geq 15 \end{cases} \end{aligned}$$

From the above definition it is clear that $g(x)$ is not differentiable at $x = 5, 10, 15$.

4. Let us draw the graph of $y = f(x)$, as shown below

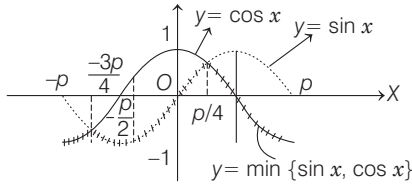

Clearly, the function $f(x) = \min\{\sin x, \cos x\}$ is not differentiable at $x = -\frac{3\pi}{4}$ and $\frac{\pi}{4}$ [these are point of intersection of graphs of $\sin x$ and $\cos x$ in $(-\pi, \pi)$, on which function has sharp edges]. So, $S = \left\{-\frac{3\pi}{4}, \frac{\pi}{4}\right\}$,

which is a subset of $\left\{-\frac{3\pi}{4}, -\frac{\pi}{4}, \frac{3\pi}{4}, \frac{\pi}{4}\right\}$

5. We have,

$$\begin{aligned} f(x) &= \sin|x| - |x| + 2(x - \pi)\cos|x| \\ f(x) &= \begin{cases} -\sin x + x + 2(x - \pi)\cos x, & \text{if } x < 0 \\ \sin x - x + 2(x - \pi)\cos x, & \text{if } x \geq 0 \end{cases} \\ &\quad [\because \sin(-\theta) = -\sin \theta \text{ and } \cos(-\theta) = \cos \theta] \\ \therefore f'(x) &= \begin{cases} -\cos x + 1 + 2\cos x - 2(x - \pi)\sin x; & \text{if } x < 0 \\ \cos x - 1 + 2\cos x - 2(x - \pi)\sin x, & \text{if } x > 0 \end{cases} \end{aligned}$$

Clearly, $f(x)$ is differentiable everywhere except possibly at $x = 0$

$[\because f'(x)$ exist for $x < 0$ and $x > 0]$

$$\text{Here, } Rf'(0) = \lim_{x \rightarrow 0^+} (3\cos x - 1 - 2(x - \pi)\sin x) = 3 - 1 - 0 = 2$$

$$\text{and } Lf'(0) = \lim_{x \rightarrow 0^-} (\cos x + 1 - 2(x - \pi)\sin x) = 1 + 1 - 0 = 2$$

$$\therefore Rf'(0) = Lf'(0)$$

So, $f(x)$ is differentiable at all values of x .

$$\Rightarrow K = \phi$$

6. **Key Idea** This type of problem can be solved graphically.

$$\text{We have, } f(x) = \begin{cases} -1, & -2 \leq x < 0 \\ x^2 - 1, & 0 \leq x \leq 2 \end{cases}$$

$$\text{and } g(x) = |f(x)| + f(|x|)$$

$$\text{Clearly, } |f(x)| = \begin{cases} 1, & -2 \leq x < 0 \\ |x^2 - 1|, & 0 \leq x \leq 2 \end{cases}$$

$$= \begin{cases} 1, & -2 \leq x < 0 \\ -(x^2 - 1), & 0 \leq x < 1 \\ x^2 - 1, & 1 \leq x \leq 2 \end{cases}$$

$$\text{and } f(|x|) = |x|^2 - 1, 0 \leq |x| \leq 2$$

$[\because f(|x|) = -1$ is not possible as $|x| \neq 0]$

$$= x^2 - 1, |x| \leq 2 \quad [\because |x|^2 = x^2]$$

$$= x^2 - 1, -2 \leq x \leq 2$$

$$\therefore g(x) = |f(x)| + f(|x|)$$

$$= \begin{cases} 1 + x^2 - 1, & -2 \leq x < 0 \\ -(x^2 - 1) + x^2 - 1, & 0 \leq x < 1 \\ x^2 - 1 + x^2 - 1, & 1 \leq x \leq 2 \end{cases}$$

$$= \begin{cases} x^2, & -2 \leq x < 0 \\ 0, & 0 \leq x < 1 \\ 2(x^2 - 1), & 1 \leq x \leq 2 \end{cases}$$

Now, let us draw the graph of $y = g(x)$, as shown in the figure.

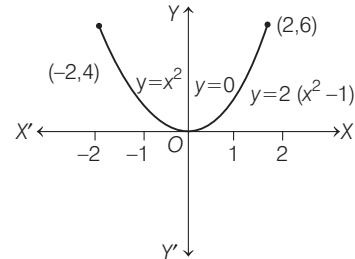

[Here, $y = 2(x^2 - 1)$ or $x^2 = \frac{1}{2}(y + 2)$ represent a parabola with vertex $(0, -2)$ and it open upward]

Note that there is a sharp edge at $x = 1$ only, so $g(x)$ is not differentiable at $x = 1$ only.

7. **Key Idea** This type of questions can be solved graphically.

Given, $f: (-1, 1) \rightarrow \mathbf{R}$, such that

$$f(x) = \max\{-|x|, -\sqrt{1-x^2}\}$$

On drawing the graph, we get the following figure.

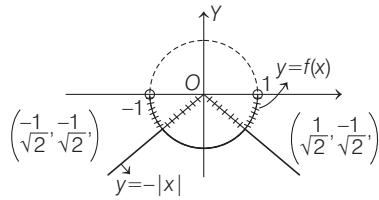

[∵ graph of $y = -|x|$ is

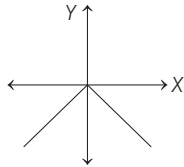

and graph of $y = -\sqrt{1-x^2}$

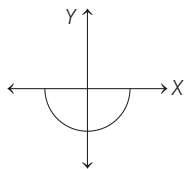

[∵ $x^2 + y^2 = 1$ represent a complete circle]

$$\Rightarrow f(x) = \begin{cases} -\sqrt{1-x^2}, & -1 < x \leq -\frac{1}{\sqrt{2}} \\ -|x|, & -\frac{1}{\sqrt{2}} < x \leq \frac{1}{\sqrt{2}} \\ -\sqrt{1-x^2}, & \frac{1}{\sqrt{2}} < x < 1 \end{cases}$$

From the figure, it is clear that function have sharp edges, at $x = -\frac{1}{\sqrt{2}}, 0, \frac{1}{\sqrt{2}}$

∴ Function is not differentiable at 3 points.

8. Key Idea This type of problem can be solved graphically

$$\text{We have, } f(x) = \begin{cases} \max\{|x|, x^2\}, & |x| \leq 2 \\ 8 - 2|x|, & 2 < |x| \leq 4 \end{cases}$$

Let us draw the graph of $y = f(x)$

For $|x| \leq 2$ $f(x) = \max\{|x|, x^2\}$

Let us first draw the graph of $y = |x|$ and $y = x^2$ as shown in the following figure.

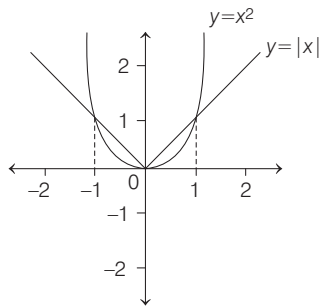

Clearly, $y = |x|$ and $y = x^2$ intersect at $x = -1, 0, 1$
Now, the graph of $y = \max\{|x|, x^2\}$ for $|x| \leq 2$ is

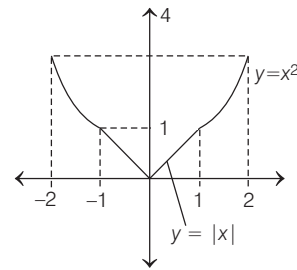

For $|x| \in (2, 4]$

$$f(x) = 8 - 2|x| = \begin{cases} 8 - 2x, & x \in (2, 4] \\ 8 + 2x, & x \in [-4, -2) \end{cases}$$

$$\left[\begin{array}{l} \because 2 < |x| \leq 4 \\ \Rightarrow |x| > 2 \text{ and } |x| \leq 4 \end{array} \right]$$

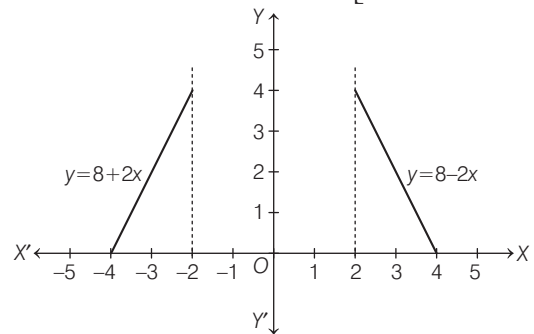

Hence, the graph of $y = f(x)$ is

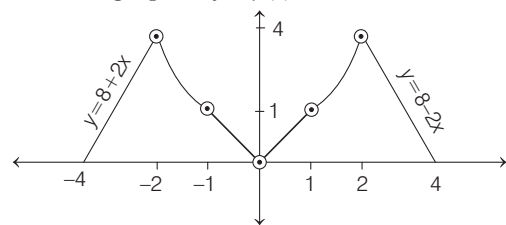

From the graph it is clear that at $x = -2, -1, 0, 1, 2$ the curve has sharp edges and hence at these points f is not differentiable.

9. Given, $|f(x) - f(y)| \leq 2|x - y|^{\frac{3}{2}}, \forall x, y \in R$

$$\Rightarrow \frac{|f(x) - f(y)|}{|x - y|} \leq 2|x - y|^{\frac{1}{2}}$$

(dividing both sides by $|x - y|$)

Put $x = x + h$ and $y = x$, where h is very close to zero.

$$\Rightarrow \lim_{h \rightarrow 0} \left| \frac{f(x+h) - f(x)}{(x+h) - x} \right| \leq \lim_{h \rightarrow 0} 2|(x+h) - x|^{\frac{1}{2}}$$

$$\Rightarrow \lim_{h \rightarrow 0} \left| \frac{f(x+h) - f(x)}{h} \right| \leq \lim_{h \rightarrow 0} 2|h|^{\frac{1}{2}}$$

$$\Rightarrow \left| \lim_{h \rightarrow 0} \frac{f(x+h) - f(x)}{h} \right| \leq 0$$

[substituting limit directly on right hand

side and using $\lim_{x \rightarrow a} |f(x)| = \left| \lim_{x \rightarrow a} f(x) \right|$

220 Limit, Continuity and Differentiability

$$\Rightarrow |f'(x)| \leq 0 \quad \left(\because \lim_{h \rightarrow 0} \frac{f(x+h) - f(x)}{h} = f'(x) \right)$$

$$\Rightarrow |f'(x)| = 0 \quad (\because |f'(x)| \text{ can not be less than zero})$$

$$\Rightarrow f'(x) = 0 \quad [\because |x| = 0 \Leftrightarrow x = 0]$$

$\Rightarrow f(x)$ is a constant function.

Since, $f(0) = 1$, therefore $f(x)$ is always equal to 1.

$$\text{Now, } \int_0^1 (f(x))^2 dx = \int_0^1 dx = [x]_0^1 = (1 - 0) = 1$$

10. We have,

$$f(x) = |x - \pi|(e^{x^2} - 1) \sin |x|$$

$$f(x) = \begin{cases} (x - \pi)(e^{-x} - 1) \sin x, & x < 0 \\ -(x - \pi)(e^x - 1) \sin x, & 0 \leq x < \pi \\ (x - \pi)(e^x - 1) \sin x, & x \geq \pi \end{cases}$$

We check the differentiability at $x = 0$ and π .

We have,

$$f'(x) = \begin{cases} (x - \pi)(e^{-x} - 1) \cos x + (e^{-x} - 1) \sin x \\ \quad + (x - \pi) \sin x e^{-x} (-1), & x < 0 \\ -[(x - \pi)(e^x - 1) \cos x + (e^x - 1) \sin x \\ \quad + (x - \pi) \sin x e^x], & 0 < x < \pi \\ (x - \pi)(e^x - 1) \cos x + (e^x - 1) \sin x \\ \quad + (x - \pi) \sin x e^x, & x > \pi \end{cases}$$

Clearly,

$$\lim_{x \rightarrow 0^-} f'(x) = 0 = \lim_{x \rightarrow 0^+} f'(x)$$

$$\text{and } \lim_{x \rightarrow \pi^-} f'(x) = 0 = \lim_{x \rightarrow \pi^+} f'(x)$$

$\therefore f$ is differentiable at $x = 0$ and $x = \pi$

Hence, f is differentiable for all x .

11. We have, $f(x) = |\log 2 - \sin x|$ and $g(x) = f(f(x))$, $x \in R$

Note that, for $x \rightarrow 0$, $\log 2 > \sin x$

$$\therefore f(x) = \log 2 - \sin x$$

$$\Rightarrow g(x) = \log 2 - \sin(\log 2 - \sin x)$$

$$= \log 2 - \sin(\log 2 - \sin x)$$

Clearly, $g(x)$ is differentiable at $x = 0$ as $\sin x$ is differentiable.

$$\text{Now, } g'(x) = -\cos(\log 2 - \sin x) (-\cos x)$$

$$= \cos x \cdot \cos(\log 2 - \sin x)$$

$$\Rightarrow g'(0) = 1 \cdot \cos(\log 2)$$

12. Given, $f(0) = 2 = g(1)$, $g(0) = 0$ and $f(1) = 6$
 f and g are differentiable in $(0, 1)$.

$$\text{Let } h(x) = f(x) - 2g(x) \quad \dots(i)$$

$$h(0) = f(0) - 2g(0) = 2 - 0 = 2$$

$$\text{and } h(1) = f(1) - 2g(1) = 6 - 2(2) = 2$$

$$h(0) = h(1) = 2$$

Hence, using Rolle's theorem,

$$h'(c) = 0, \text{ such that } c \in (0, 1)$$

Differentiating Eq. (i) at c , we get

$$\Rightarrow f'(c) - 2g'(c) = 0$$

$$\Rightarrow f'(c) = 2g'(c)$$

13. **PLAN** To check differentiability at a point we use RHD and LHD at a point and if RHD = LHD, then $f(x)$ is differentiable at the point.

Description of Situation

$$\text{As, } R\{f'(x)\} = \lim_{h \rightarrow 0} \frac{f(x+h) - f(x)}{h}$$

$$\text{and } L\{f'(x)\} = \lim_{h \rightarrow 0} \frac{f(x-h) - f(x)}{-h}$$

Here, students generally gets confused in defining modulus. To check differentiable at $x = 0$,

$$R\{f'(0)\} = \lim_{h \rightarrow 0} \frac{f(0+h) - f(0)}{h}$$

$$= \lim_{h \rightarrow 0} \frac{h^2 \left| \cos \frac{\pi}{h} \right| - 0}{h} = \lim_{h \rightarrow 0} h \cdot \left| \cos \frac{\pi}{h} \right| = 0$$

$$L\{f'(0)\} = \lim_{h \rightarrow 0} \frac{f(0-h) - f(0)}{-h} = \lim_{h \rightarrow 0} \frac{h^2 \left| \cos \left(-\frac{\pi}{h} \right) \right| - 0}{-h} = 0$$

So, $f(x)$ is differentiable at $x = 0$.

To check differentiability at $x = 2$,

$$R\{f'(2)\} = \lim_{h \rightarrow 0} \frac{f(2+h) - f(2)}{h}$$

$$= \lim_{h \rightarrow 0} \frac{(2+h)^2 \left| \cos \left(\frac{\pi}{2+h} \right) \right| - 0}{h} = \lim_{h \rightarrow 0} \frac{(2+h)^2 \cdot \cos \left(\frac{\pi}{2+h} \right)}{h}$$

$$= \lim_{h \rightarrow 0} \frac{(2+h)^2 \cdot \sin \left(\frac{\pi}{2} - \frac{\pi}{2+h} \right)}{h}$$

$$= \lim_{h \rightarrow 0} \frac{(2+h)^2 \cdot \sin \left(\frac{\pi h}{2(2+h)} \right)}{h \cdot \frac{\pi}{2(2+h)}} \cdot \frac{\pi}{2(2+h)} = \pi$$

$$\text{and } L\{f'(2)\} = \lim_{h \rightarrow 0} \frac{f(2-h) - f(2)}{-h}$$

$$= \lim_{h \rightarrow 0} \frac{(2-h)^2 \cdot \left| \cos \frac{\pi}{2-h} \right| - 2^2 \cdot \left| \cos \frac{\pi}{2} \right|}{-h}$$

$$= \lim_{h \rightarrow 0} \frac{(2-h)^2 - \left(-\cos \frac{\pi}{2-h} \right) - 0}{-h}$$

$$= \lim_{h \rightarrow 0} \frac{-(2-h)^2 \cdot \sin \left(\frac{\pi}{2} - \frac{\pi}{2-h} \right)}{h}$$

$$= \lim_{h \rightarrow 0} \frac{(2-h)^2 \cdot \sin \left(-\frac{\pi h}{2(2-h)} \right)}{h \times \frac{-\pi}{2(2-h)}} \times \frac{-\pi}{2(2-h)} = -\pi$$

Thus, $f(x)$ is differentiable at $x = 0$ but not at $x = 2$.

14. Given, $g(x) = \frac{(x-1)^n}{\log \cos^m(x-1)}$; $0 < x < 2, m \neq 0, n$ are integers and $|x-1| = \begin{cases} x-1, & x \geq 1 \\ 1-x, & x < 1 \end{cases}$

The left hand derivative of $|x-1|$ at $x=1$ is $p = -1$.

Also, $\lim_{x \rightarrow 1^+} g(x) = p = -1$

$$\Rightarrow \lim_{h \rightarrow 0} \frac{(1+h-1)^n}{\log \cos^m(1+h-1)} = -1$$

$$\Rightarrow \lim_{h \rightarrow 0} \frac{h^n}{\log \cos^m h} = -1$$

$$\Rightarrow \lim_{h \rightarrow 0} \frac{h^n}{m \log \cos h} = -1$$

$$\Rightarrow \lim_{h \rightarrow 0} \frac{n \cdot h^{n-1}}{m \frac{1}{\cos h} (-\sin h)} = -1$$

[using L'Hospital's rule]

$$\Rightarrow \lim_{h \rightarrow 0} \left(-\frac{n}{m}\right) \cdot \frac{h^{n-2}}{\left(\frac{\tan h}{h}\right)} = -1 \Rightarrow \left(\frac{n}{m}\right) \lim_{h \rightarrow 0} \frac{h^{n-2}}{\left(\frac{\tan h}{h}\right)} = 1$$

$$\Rightarrow n = 2 \text{ and } \frac{n}{m} = 1 \Rightarrow m = n = 2$$

15. Given, $f(1) = f\left(\frac{1}{2}\right) = f\left(\frac{1}{3}\right) = \dots = \lim_{n \rightarrow \infty} f\left(\frac{1}{n}\right) = 0$

as $f\left(\frac{1}{n}\right) = 0; n \in \text{integers and } n \geq 1$.

$$\Rightarrow \lim_{n \rightarrow \infty} f\left(\frac{1}{n}\right) = 0 \Rightarrow f(0) = 0$$

Since, there are infinitely many points in neighbourhood of $x=0$.

$$\therefore f(x) = 0$$

$$\Rightarrow f'(x) = 0$$

$$\Rightarrow f'(0) = 0$$

Hence, $f(0) = f'(0) = 0$

16. Using graphical transformation.

As, we know that, the function is not differentiable at sharp edges.

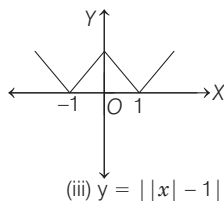
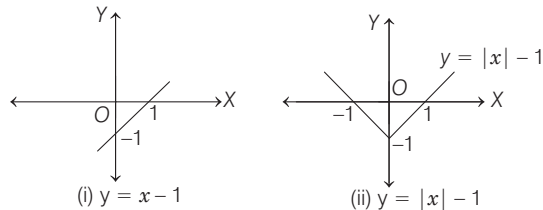

In function,

$y = ||x| - 1|$ we have 3 sharp edges at $x = -1, 0, 1$.

Hence, $f(x)$ is not differentiable at $\{0, \pm 1\}$.

17. Given, $f(x) = \begin{cases} \frac{1}{2}(-x-1), & \text{if } x < -1 \\ \tan^{-1} x, & \text{if } -1 \leq x \leq 1 \\ \frac{1}{2}(x-1), & \text{if } x > 1 \end{cases}$

$f(x)$ is discontinuous at $x = -1$ and $x = 1$.

\therefore Domain of $f'(x) \in \mathbb{R} - \{-1, 1\}$

18. RHD of $\sin(|x|) - |x| = \lim_{h \rightarrow 0} \frac{\sin h - h}{h} = 1 - 1 = 0$

[$\because f(0) = 0$]

LHD of $\sin(|x|) - |x|$

$$= \lim_{h \rightarrow 0} \frac{\sin|-h| - |-h|}{-h} = \frac{\sin h - h}{-h} = 0$$

Therefore, (d) is the answer.

19. Given, $f(x) = [x] \sin \pi x$

If x is just less than k , $[x] = k - 1$

$$\therefore f(x) = (k-1) \sin \pi x$$

$$\text{LHD of } f(x) = \lim_{x \rightarrow k} \frac{(k-1) \sin \pi x - k \sin \pi k}{x - k}$$

$$= \lim_{x \rightarrow k} \frac{(k-1) \sin \pi x}{x - k},$$

$$= \lim_{h \rightarrow 0} \frac{(k-1) \sin \pi (k-h)}{-h}$$

[where $x = k - h$]

$$= \lim_{h \rightarrow 0} \frac{(k-1) (-1)^{k-1} \cdot \sin h \pi}{-h} = (-1)^k (k-1) \pi$$

20. Given, $f(x) = \max\{x, x^3\}$ considering the graph separately, $y = x^3$ and $y = x$

NOTE $y = x^3$ is odd order parabola and $y = x$ is always intersect at $(1, 1)$ and $(-1, -1)$.

$$\text{Now, } f(x) = \begin{cases} x & \text{in } (-\infty, -1] \\ x^3 & \text{in } (-1, 0] \\ x & \text{in } (0, 1] \\ x^3 & \text{in } (1, \infty) \end{cases}$$

$$\Rightarrow f'(x) = \begin{cases} 1 & \text{in } (-\infty, -1] \\ 3x^2 & \text{in } (-1, 0] \\ 1 & \text{in } (0, 1] \\ 3x^2 & \text{in } (1, \infty) \end{cases}$$

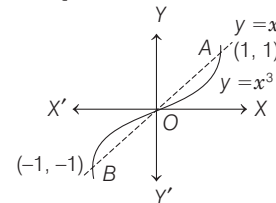

The point of consideration are

$$f'(-1^-) = 1 \quad \text{and} \quad f'(-1^+) = 3$$

$$f'(-0^-) = 0 \quad \text{and} \quad f'(0^+) = 1$$

$$f'(1^-) = 1 \quad \text{and} \quad f'(1^+) = 3$$

Hence, f is not differentiable at $-1, 0, 1$.

222 Limit, Continuity and Differentiability

21. Let $h(x) = |x|$, then $g(x) = |f(x)| = h\{f(x)\}$
 Since, composition of two continuous functions is continuous, g is continuous if f is continuous. So, answer is (c).
 (a) Let $f(x) = x \Rightarrow g(x) = |x|$
 Now, $f(x)$ is an onto function. Since, co-domain of x is R and range of x is R . But $g(x)$ is into function. Since, range of $g(x)$ is $[0, \infty)$ but co-domain is given R . Hence, (a) is wrong.
 (b) Let $f(x) = x \Rightarrow g(x) = |x|$. Now, $f(x)$ is one-one function but $g(x)$ is many-one function. Hence, (b) is wrong.
 (d) Let $f(x) = x \Rightarrow g(x) = |x|$. Now, $f(x)$ is differentiable for all $x \in R$ but $g(x) = |x|$ is not differentiable at $x = 0$. Hence, (d) is wrong.

22. Function $f(x) = (x^2 - 1)|x^2 - 3x + 2| + \cos(|x|)$... (i)

NOTE In differentiability of $|f(x)|$ we have to consider critical points for which $f(x) = 0$.

$|x|$ is not differentiable at $x = 0$

$$\text{but } \cos|x| = \begin{cases} \cos(-x), & \text{if } x < 0 \\ \cos x, & \text{if } x \geq 0 \end{cases}$$

$$\Rightarrow \cos|x| = \begin{cases} \cos x, & \text{if } x < 0 \\ \cos x, & \text{if } x \geq 0 \end{cases}$$

Therefore, it is differentiable at $x = 0$.

$$\text{Now, } |x^2 - 3x + 2| = |(x-1)(x-2)| = \begin{cases} (x-1)(x-2), & \text{if } x < 1 \\ (x-1)(2-x), & \text{if } 1 \leq x < 2 \\ (x-1)(x-2), & \text{if } 2 \leq x \end{cases}$$

Therefore,

$$f(x) = \begin{cases} (x^2 - 1)(x-1)(x-2) + \cos x, & \text{if } -\infty < x < 1 \\ -(x^2 - 1)(x-1)(x-2) + \cos x, & \text{if } 1 \leq x < 2 \\ (x^2 - 1)(x-1)(x-2) + \cos x, & \text{if } 2 \leq x < \infty \end{cases}$$

Now, $x = 1, 2$ are critical point for differentiability. Because $f(x)$ is differentiable on other points in its domain.

Differentiability at $x = 1$

$$\begin{aligned} Lf'(1) &= \lim_{x \rightarrow 1^-} \frac{f(x) - f(1)}{x - 1} \\ &= \lim_{x \rightarrow 1^-} \left[(x^2 - 1)(x-2) + \frac{\cos x - \cos 1}{x-1} \right] \\ &= 0 - \sin 1 = -\sin 1 \\ \left[\because \lim_{x \rightarrow 1^-} \frac{\cos x - \cos 1}{x-1} = \frac{d}{dx}(\cos x) \text{ at } x = 1 = -\sin x \text{ at } x = 1 = -\sin 1 \right] \end{aligned}$$

$$\begin{aligned} \text{and } Rf'(1) &= \lim_{x \rightarrow 1^+} \frac{f(x) - f(1)}{x - 1} \\ &= \lim_{x \rightarrow 1^+} \left[-(x^2 - 1)(x-2) + \frac{\cos x - \cos 1}{x-1} \right] \\ &= 0 - \sin 1 = -\sin 1 \quad [\text{same approach}] \end{aligned}$$

$\therefore Lf'(1) = Rf'(1)$. Therefore, function is differentiable at $x = 1$.

$$\begin{aligned} \text{Again, } Lf'(2) &= \lim_{x \rightarrow 2^-} \frac{f(x) - f(2)}{x - 2} \\ &= \lim_{x \rightarrow 2^-} \left[-(x^2 - 1)(x-1) + \frac{\cos x - \cos 2}{x-2} \right] \\ &= -(4-1)(2-1) - \sin 2 = -3 - \sin 2 \end{aligned}$$

$$\begin{aligned} \text{and } Rf'(2) &= \lim_{x \rightarrow 2^+} \frac{f(x) - f(2)}{x - 2} \\ &= \lim_{x \rightarrow 2^+} \left[(x^2 - 1)(x-1) + \frac{\cos x - \cos 2}{x-2} \right] \\ &= (2^2 - 1)(2-1) - \sin 2 = 3 - \sin 2 \end{aligned}$$

So, $Lf'(2) \neq Rf'(2)$, f is not differentiable at $x = 2$

Therefore, (d) is the answer.

23. Given, $f(x) = \frac{x}{1+|x|} = \begin{cases} \frac{x}{1+x}, & x \geq 0 \\ \frac{x}{1-x}, & x < 0 \end{cases}$

$$\therefore f'(x) = \begin{cases} \frac{(1+x) \cdot 1 - x \cdot 1}{(1+x)^2}, & x \geq 0 \\ \frac{(1-x) \cdot 1 - x(-1)}{(1-x)^2}, & x < 0 \end{cases}$$

$$\Rightarrow f'(x) = \begin{cases} \frac{1}{(1+x)^2}, & x \geq 0 \\ \frac{1}{(1-x)^2}, & x < 0 \end{cases}$$

$$\therefore \text{RHD at } x = 0 \Rightarrow \lim_{x \rightarrow 0} \frac{1}{(1+x)^2} = 1$$

$$\text{and } \text{LHD at } x = 0 \Rightarrow \lim_{x \rightarrow 0} \frac{1}{(1-x)^2} = 1$$

Hence, $f(x)$ is differentiable for all x .

24. Since, $f(x)$ is continuous and differentiable where $f(0) = 1$ and $f'(0) = -1$, $f(x) > 0, \forall x$.

Thus, $f(x)$ is decreasing for $x > 0$ and concave down.

$$\Rightarrow f''(x) < 0$$

Therefore, (a) is answer.

25. Here, $f(x) = \frac{\tan \pi [(x - \pi)]}{1 + [x]^2}$

Since, we know $\pi [(x - \pi)] = n\pi$ and $\tan n\pi = 0$

$$\therefore 1 + [x]^2 \neq 0$$

$$\therefore f(x) = 0, \forall x$$

Thus, $f(x)$ is a constant function.

$\therefore f'(x), f''(x), \dots$ all exist for every x , their value being 0.

$\Rightarrow f'(x)$ exists for all x .

26. The given function $f: R \rightarrow R$ is satisfying as

$$f(x+y) = f(x) + f(y) + f(x)f(y).$$

So,
$$f'(x) = \lim_{h \rightarrow 0} \frac{f(x+h) - f(x)}{h}$$

$$= \lim_{h \rightarrow 0} \frac{f(x) + f(h) + f(x)f(h) - f(x)}{h}$$

$$= \lim_{h \rightarrow 0} \frac{f(h)}{h} (1 + f(x))$$

$$\therefore f(x) = xg(x)$$

$$\Rightarrow g(x) = \frac{f(x)}{x}$$

$$\therefore \lim_{x \rightarrow 0} \frac{f(x)}{x} = \lim_{x \rightarrow 0} g(x) = 1 \quad (\text{given})$$

$$\therefore f'(x) = 1 + f(x)$$

$$\Rightarrow \frac{f'(x)}{1 + f(x)} = 1$$

$$\Rightarrow \log_e(1 + f(x)) = x + c$$

$$\Rightarrow 1 + f(x) = e^{x+c}$$

$$\Rightarrow f(x) = e^{x+c} - 1$$

$$\therefore f(0) = 0$$

$$\therefore c = 0$$

Therefore, $f(x) = e^x - 1$ is differentiable at every $x \in R$.

And $f'(x) = e^x \Rightarrow f'(0) = 1$

Now, $g(x) = \frac{f(x)}{x} = \frac{e^x - 1}{x}$ and if $g(0) = 1$

LHD (at $x=0$) of

$$g(x) = \lim_{h \rightarrow 0} \frac{g(0-h) - g(0)}{-h}$$

$$= \lim_{h \rightarrow 0} \frac{\frac{e^{-h} - 1}{-h} - 1}{-h}$$

$$= \lim_{h \rightarrow 0} \frac{e^{-h} - 1 + h}{h^2} = \frac{1}{2}$$

and, RHD (at $x=0$) of

$$g(x) = \lim_{h \rightarrow 0} \frac{g(0+h) - g(0)}{h} = \lim_{h \rightarrow 0} \frac{e^h - 1 - h}{h^2} = \frac{1}{2}$$

So, if $g(0) = 1$, then g is differentiable at every $x \in R$.

- 27.** Given functions $f: R \rightarrow R$ be defined by $f(x) = x^3 - x^2 + (x-1)\sin x$ and $g: R \rightarrow R$ be an arbitrary function.

Now, let g is continuous at $x=1$, then

$$\lim_{x \rightarrow 1^-} \frac{(fg)(x) - (fg)(1)}{x-1} = \lim_{h \rightarrow 0} \frac{(fg)(1-h) - (fg)(1)}{1-h-1}$$

$$\therefore (fg)(x) = f(x) \cdot g(x) \quad (\text{given})$$

$$= \lim_{h \rightarrow 0} \frac{f(1-h) \cdot g(1-h) - f(1) \cdot g(1)}{-h}$$

$$= \lim_{h \rightarrow 0} \frac{f(1-h) \cdot g(1)}{-h}$$

{ $\therefore f(1) = 0$ and g is continuous at $x=1$, so $g(1-h) = g(1)$ }

$$= g(1) \lim_{h \rightarrow 0} \frac{(1-h)^2(-h) + (-h)\sin(1-h)}{-h}$$

$$= (1 + \sin 1)g(1)$$

Similarly,

$$\lim_{x \rightarrow 1^+} \frac{(fg)(x) - (fg)(1)}{x-1} = \lim_{h \rightarrow 0} \frac{f(1+h) \cdot g(1)}{h}$$

$$= g(1) \lim_{h \rightarrow 0} \frac{(1+h)^2(h) + h\sin(1+h)}{h}$$

$$= (1 + \sin 1)g(1)$$

\therefore RHD and LHD of function fg at $x=1$ is finitely exists and equal, so fg is differentiable at $x=1$

Now, let $(fg)(x)$ is differentiable at $x=1$, so

$$\lim_{x \rightarrow 1^-} \frac{(fg)(x) - (fg)(1)}{x-1} = \lim_{x \rightarrow 1^+} \frac{(fg)(x) - (fg)(1)}{x-1}$$

$$\Rightarrow \lim_{x \rightarrow 1^-} \frac{f(x)g(x) - f(1)g(1)}{x-1} = \lim_{x \rightarrow 1^+} \frac{f(x)g(x) - f(1)g(1)}{x-1}$$

$$\Rightarrow \lim_{x \rightarrow 1^-} \frac{f(x)g(x)}{x-1} = \lim_{x \rightarrow 1^+} \frac{f(x)g(x)}{x-1} \quad \{\therefore f(1) = 0\}$$

$$\Rightarrow \lim_{h \rightarrow 0} \frac{f(1-h)g(1-h)}{-h} = \lim_{h \rightarrow 0} \frac{f(1+h)g(1+h)}{h}$$

$$\Rightarrow \lim_{h \rightarrow 0} \frac{[(1-h)^2(-h) + (-h)\sin(1-h)]g(1-h)}{-h}$$

$$= \lim_{h \rightarrow 0} \frac{[(1+h)^2(h) + (h)\sin(1+h)]g(1+h)}{h}$$

$$\Rightarrow \lim_{h \rightarrow 0} [(1-h)^2 + \sin(1-h)]g(1-h) = \lim_{h \rightarrow 0} [(1+h)^2 + \sin(1+h)]g(1+h)$$

It does not mean that $g(x)$ is continuous or differentiable at $x=1$.

But if g is differentiable at $x=1$, then it must be continuous at $x=1$ and so fg is differentiable at $x=1$.

- 28.** It is given, that $f: R \rightarrow R$ and

Property 1 : $\lim_{h \rightarrow 0} \frac{f(h) - f(0)}{\sqrt{|h|}}$ exists and finite, and

Property 2 : $\lim_{h \rightarrow 0} \frac{f(h) - f(0)}{h^2}$ exists and finite.

Option a,

P2 : $\lim_{h \rightarrow 0} \frac{\sin h - \sin 0}{h^2} = \lim_{h \rightarrow 0} \frac{1}{h} \left(\frac{\sin h}{h} \right) =$ doesn't exist.

Option b,

P1 : $\lim_{h \rightarrow 0} \frac{h^{23} - 0}{\sqrt{|h|}} = \lim_{h \rightarrow 0} h^{23-1/2} = \lim_{h \rightarrow 0} h^{45/2} = 0$

exists and finite.

Option c,

P1 : $\lim_{h \rightarrow 0} \frac{|h| - 0}{\sqrt{|h|}} = \lim_{h \rightarrow 0} \sqrt{|h|} = 0$, exists and finite.

Option d,

P2 : $\lim_{h \rightarrow 0} \frac{h|h| - 0}{h^2} = \lim_{h \rightarrow 0} \frac{|h|}{h}$

$$= \begin{cases} 1, & \text{if } h \rightarrow 0^+ \\ -1, & \text{if } h \rightarrow 0^- \end{cases}$$

So $\lim_{h \rightarrow 0} \frac{f(h) - f(0)}{h^2}$ does not exist.

Hence, options (b) and (c) are correct.

224 Limit, Continuity and Differentiability

29. We have,

$$(f(0))^2 + (f'(0))^2 = 85$$

and

$$f: R \rightarrow [-2, 2]$$

(a) Since, f is twice differentiable function, so f is continuous function.

\therefore This is true for every continuous function.

Hence, we can always find $x \in (r, s)$, where $f(x)$ is one-one.

\therefore This statement is true.

(b) By L.M.V.T

$$f'(c) = \frac{f(b) - f(a)}{b - a} \Rightarrow |f'(c)| = \left| \frac{f(b) - f(a)}{b - a} \right|$$

$$\Rightarrow |f'(x_0)| = \left| \frac{f(0) - f(-4)}{0 + 4} \right| = \left| \frac{f(0) - f(-4)}{4} \right|$$

Range of f is $[-2, 2]$

$$\therefore -4 \leq f(0) - f(-4) \leq 4 \Rightarrow 0 \leq \left| \frac{f(0) - f(-4)}{4} \right| \leq 1$$

Hence, $|f'(x_0)| \leq 1$.

Hence, statement is true.

(c) As no function is given, then we assume

$$f(x) = 2 \sin \left(\frac{\sqrt{85} x}{2} \right)$$

$$\therefore f'(x) = \sqrt{85} \cos \left(\frac{\sqrt{85} x}{2} \right)$$

$$\text{Now, } (f(0))^2 + (f'(0))^2 = (2 \sin 0)^2 + (\sqrt{85} \cos 0)^2$$

$$(f(0))^2 + (f'(0))^2 = 85$$

and $\lim_{x \rightarrow \infty} f(x)$ does not exist.

Hence, statement is false.

(d) From option b, $|f'(x_0)| \leq 1$ and $x_0 \in (-4, 0)$

$$\therefore (f'(x_0))^2 \leq 1$$

$$\text{Hence, } g(x_0) = (f(x_0))^2 + (f'(x_0))^2 \leq 4 + 1$$

$[\because f(x_0) \in [-2, 2]]$

$$\Rightarrow g(x_0) \leq 5$$

Now, let $p \in (-4, 0)$ for which $g(p) = 5$

Similarly, let q be smallest positive number $q \in (0, 4)$

such that $g(q) = 5$

Hence, by Rolle's theorem is (p, q)

$g'(c) = 0$ for $\alpha \in (-4, 4)$ and since $g(x)$ is greater than 5 as we move from $x = p$ to $x = q$

and $f(x)^2 \leq 4 \Rightarrow (f'(x))^2 \geq 1$ in (p, q)

Thus, $g'(c) = 0$

$$\Rightarrow f'f + f'f' = 0$$

So, $f(\alpha) + f'(\alpha) = 0$ and $f'(\alpha) \neq 0$

Hence, statement is true.

30. Given, $\lim_{t \rightarrow x} \frac{f(x) \sin t - f(t) \sin x}{t - x} = \sin^2 x$

Using L' Hospital rules

$$\lim_{t \rightarrow x} \frac{f(x) \cos t - f'(t) \sin x}{1} = \sin^2 x$$

$$\Rightarrow f(x) \cos x - f'(x) \sin x = \sin^2 x$$

$$\Rightarrow f'(x) \sin x - f(x) \cos x = -\sin^2 x$$

$$\Rightarrow \frac{f'(x) \sin x - f(x) \cos x}{\sin^2 x} = -1$$

$$\Rightarrow d \left(\frac{f(x)}{\sin x} \right) = -1$$

On integrating, we get

$$\frac{f(x)}{\sin x} = -x + C \Rightarrow f(x) = -x \sin x + C \sin x$$

$$\text{It is given that } x = \frac{\pi}{6}, f\left(\frac{\pi}{6}\right) = -\frac{\pi}{12}$$

$$\therefore f\left(\frac{\pi}{6}\right) = -\frac{\pi}{6} \sin \frac{\pi}{6} + C \sin \frac{\pi}{6} = -\frac{\pi}{12} = -\frac{\pi}{12} + \frac{1}{2} C$$

$$\Rightarrow C = 0$$

$$\therefore f(x) = -x \sin x$$

(a) $f(x) = -x \sin x$

$$f\left(\frac{\pi}{4}\right) = -\frac{\pi}{4} \sin \frac{\pi}{4} = -\frac{\pi}{4\sqrt{2}} \text{ false}$$

(b) $f(x) = -x \sin x$

$$\sin x > x - \frac{x^3}{6}, \forall x \in (0, \pi) \Rightarrow -x \sin x < -x^2 + \frac{x^4}{6}$$

$$\Rightarrow f(x) < \frac{x^4}{6} - x^2, \forall x \in (0, \pi)$$

It is true

(c) $f(x) = -x \sin x$

$$f'(x) = -\sin x - x \cos x$$

$$f'(x) = 0$$

$$\Rightarrow -\sin x - x \cos x = 0$$

$$\tan x = -x$$

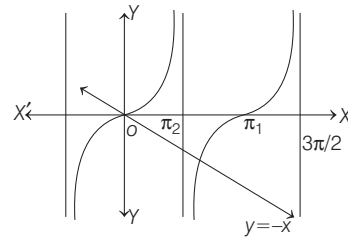

\Rightarrow There exists $\alpha \in (0, \pi)$ for which $f'(\alpha) = 0$

It is true

(d) $f(x) = -x \sin x$

$$f'(x) = -\sin x - x \cos x$$

$$f''(x) = -2 \cos x + x \sin x$$

$$f''\left(\frac{\pi}{2}\right) = \frac{\pi}{2}, f\left(\frac{\pi}{2}\right) = -\frac{\pi}{2}$$

$$\therefore f''\left(\frac{\pi}{2}\right) + f\left(\frac{\pi}{2}\right) = 0$$

It is true.

31. As, $g(f(x)) = x$

Thus, $g(x)$ is inverse of $f(x)$.

$$\Rightarrow g(f(x)) = x \Rightarrow g'(f(x)) \cdot f'(x) = 1$$

$$\therefore g'(f(x)) = \frac{1}{f'(x)} \quad \dots(i)$$

[where, $f'(x) = 3x^2 + 3$]

When $f(x) = 2$, then

$$x^3 + 3x + 2 = 2 \Rightarrow x = 0$$

i.e. when $x = 0$, then $f(x) = 2$

$$\therefore g'(f(x)) = \frac{1}{3x^2 + 3} \text{ at } (0, 2) \Rightarrow g'(2) = \frac{1}{3}$$

\therefore Option (a) is incorrect.

$$\text{Now, } h(g(g(x))) = x \Rightarrow h(g(f(x))) = f(x)$$

$$\Rightarrow h(g(x)) = f(x) \quad \dots(ii)$$

As $g(f(x)) = x$

$$\therefore h(g(3)) = f(3) = 3^3 + 3(3) + 2 = 38$$

\therefore Option (d) is incorrect.

From Eq. (ii), $h(g(x)) = f(x)$

$$\Rightarrow h(g(f(x))) = f(f(x))$$

$$\Rightarrow h(x) = f(f(x)) \quad \dots(iii)$$

[using $g(f(x)) = x$]

$$\Rightarrow h'(x) = f'(f(x)) \cdot f'(x) \quad \dots(iv)$$

Putting $x = 1$, we get

$$h'(1) = f'(f(1)) \cdot f'(1) = (3 \times 36 + 3) \times (6) = 111 \times 6 = 666$$

\therefore Option (b) is correct.

Putting $x = 0$ in Eq. (iii), we get

$$h(0) = f(f(0)) = f(2) = 8 + 6 + 2 = 16$$

\therefore Option (c) is correct.

32. Here, $f(x) = a \cos(|x^3 - x|) + b|x| \sin(|x^3 + x|)$

If $x^3 - x \geq 0$

$$\Rightarrow \cos|x^3 - x| = \cos(x^3 - x) \\ x^3 - x \leq 0$$

$$\Rightarrow \cos|x^3 - x| = \cos(x^3 - x)$$

$$\therefore \cos(|x^3 - x|) = \cos(x^3 - x), \forall x \in R \quad \dots(i)$$

Again, if $x^3 + x \geq 0$

$$\Rightarrow |x| \sin(|x^3 + x|) = x \sin(x^3 + x) \\ x^3 + x \leq 0$$

$$\Rightarrow |x| \sin(|x^3 + x|) = -x \sin\{-(x^3 + x)\}$$

$$\therefore |x| \sin(|x^3 + x|) = x \sin(x^3 + x), \forall x \in R \quad \dots(ii)$$

$$\Rightarrow f(x) = a \cos(|x^3 - x|) + b|x| \sin(|x^3 + x|)$$

$$\therefore f(x) = a \cos(x^3 - x) + bx \sin(x^3 + x) \quad \dots(iii)$$

which is clearly sum and composition of differential functions.

Hence, $f(x)$ is always continuous and differentiable.

33. Here,

$$f(x) = [x^2 - 3] = [x^2] - 3 = \begin{cases} -3, & -1/2 \leq x < 1 \\ -2, & 1 \leq x < \sqrt{2} \\ -1, & \sqrt{2} \leq x < \sqrt{3} \\ 0, & \sqrt{3} \leq x < 2 \\ 1, & x = 2 \end{cases}$$

and $g(x) = |x| f(x) + |4x - 7| f(x)$

$$= (|x| + |4x - 7|) f(x)$$

$$= (|x| + |4x - 7|) [x^2 - 3]$$

$$= \begin{cases} (-x - 4x - 7)(-3), & -1/2 \leq x < 0 \\ (x - 4x + 7)(-3), & 0 \leq x < 1 \\ (x - 4x + 7)(-2), & 1 \leq x < \sqrt{2} \\ (x - 4x + 7)(-1), & \sqrt{2} \leq x < \sqrt{3} \\ (x - 4x + 7)(0), & \sqrt{3} \leq x < 7/4 \\ (x + 4x - 7)(0), & 7/4 \leq x < 2 \\ (x + 4x - 7)(1), & x = 2 \end{cases}$$

$$\therefore g(x) = \begin{cases} 15x + 21, & -1/2 \leq x < 0 \\ 9x - 21, & 0 \leq x < 1 \\ 6x - 14, & 1 \leq x < \sqrt{2} \\ 3x - 7, & \sqrt{2} \leq x < \sqrt{3} \\ 0, & \sqrt{3} \leq x < 2 \\ 5x - 7, & x = 2 \end{cases}$$

Now, the graphs of $f(x)$ and $g(x)$ are shown below.

Graph for $f(x)$

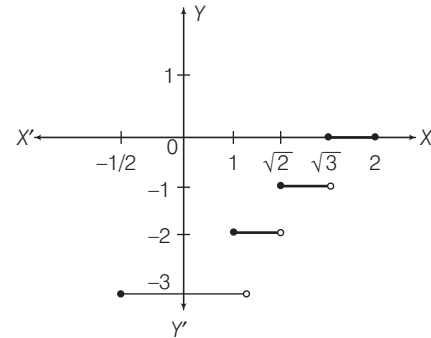

Clearly, $f(x)$ is discontinuous at 4 points.

\therefore Option (b) is correct.

Graph for $g(x)$

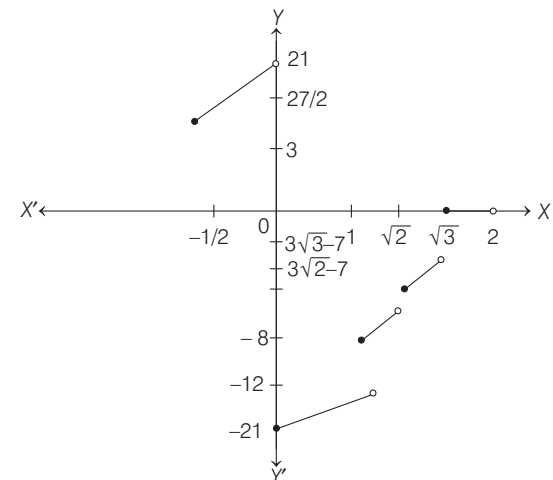

Clearly, $g(x)$ is not differentiable at 4 points, when $x \in (-1/2, 2)$.

\therefore Option (c) is correct.

226 Limit, Continuity and Differentiability

34. Here, $f(x) = \begin{cases} g(x), & x > 0 \\ 0, & x = 0 \\ -g(x), & x < 0 \end{cases}$
 $f'(x) = \begin{cases} g'(x), & x \geq 0 \\ -g'(x), & x < 0 \end{cases}$

∴ Option (a) is correct.

(b) $h(x) = e^{|x|} = \begin{cases} e^x, & x \geq 0 \\ e^{-x}, & x < 0 \end{cases}$

⇒ $h'(x) = \begin{cases} e^x, & x \geq 0 \\ -e^{-x}, & x < 0 \end{cases}$

⇒ $h'(0^+) = 1$ and $h'(0^-) = -1$

So, $h(x)$ is not differentiable at $x = 0$.

∴ Option (b) is not correct.

(c) $(f \circ h)(x) = f\{h(x)\}$ as $h(x) > 0$
 $= \begin{cases} g(e^x), & x \geq 0 \\ g(e^{-x}), & x < 0 \end{cases}$

⇒ $(f \circ h)'(x) = \begin{cases} e^x g'(e^x), & x \geq 0 \\ -e^{-x} g'(e^{-x}), & x < 0 \end{cases}$

⇒ $(f \circ h)'(0^+) = g'(1)$, $(f \circ h)'(0^-) = -g'(1)$

So, $(f \circ h)(x)$ is not differentiable at $x = 0$.

∴ Option (c) is not correct.

(d) $(h \circ f)(x) = e^{|f(x)|} = \begin{cases} e^{|g(x)|}, & x \neq 0 \\ e^0 = 1, & x = 0 \end{cases}$

Now, $(h \circ f)'(0) = \lim_{h \rightarrow 0} \frac{e^{|g(x)|} - 1}{x}$
 $= \lim_{h \rightarrow 0} \frac{e^{|g(x)|} - 1}{|g(x)|} \cdot \frac{|g(x)|}{x}$
 $= \lim_{h \rightarrow 0} \frac{e^{|g(x)|} - 1}{|g(x)|} \cdot \lim_{h \rightarrow 0} \frac{|g(x) - 0|}{|x|} \cdot \lim_{h \rightarrow 0} \frac{|x|}{x}$
 $= 1 \cdot g'(0) \cdot \lim_{h \rightarrow 0} \frac{|x|}{x} = 0$ as $g'(0) = 0$

∴ Option (d) is correct.

35. Let $F(x) = f(x) - 3g(x)$

∴ $F(-1) = 3$, $F(0) = 3$ and $F(2) = 3$

So, $F'(x)$ will vanish at least twice in $(-1, 0) \cup (0, 2)$.

∴ $F''(x) > 0$ or < 0 , $\forall x \in (-1, 0) \cup (0, 2)$

Hence, $f'(x) - 3g'(x) = 0$ has exactly one solution in $(-1, 0)$ and one solution in $(0, 2)$.

36. A function $f(x)$ is continuous at $x = a$,

if $\lim_{x \rightarrow a^-} f(x) = \lim_{x \rightarrow a^+} f(x) = f(a)$.

Also, a function $f(x)$ is differentiable at $x = a$, if

$$\lim_{x \rightarrow a^-} \frac{f(x) - f(a)}{x - a} = \lim_{x \rightarrow a^+} \frac{f(x) - f(a)}{x - a}$$

i.e. $f'(a^-) = f'(a^+)$

Given that, $f: [a, b] \rightarrow [1, \infty)$

an $g(x) = \begin{cases} 0, & x < a \\ \int_a^x f(t) dt, & a \leq x \leq b \\ \int_a^b f(t) dt, & x > b \end{cases}$

Now, $g(a^-) = 0 = g(a^+) = g(a)$

[as $g(a^+) = \lim_{x \rightarrow a^+} \int_a^x f(t) dt = 0$

and $g(a) = \int_a^a f(t) dt = 0]$

$$g(b^-) = g(b^+) = g(b) = \int_a^b f(t) dt$$

⇒ g is continuous for all $x \in R$.

Now, $g'(x) = \begin{cases} 0, & x < a \\ f(x), & a < x < b \\ 0, & x > b \end{cases}$

$g'(a^-) = 0$

but $g'(a^+) = f(a) \geq 1$

[∵ range of $f(x)$ is $[1, \infty)$, $\forall x \in [a, b]$]

⇒ g is non-differentiable at $x = a$

and $g'(b^+) = 0$

but $g'(b^-) = f(b) \geq 1$

⇒ g is not differentiable at $x = b$.

37. $f(x) = \begin{cases} -x - \frac{\pi}{2}, & x \leq -\frac{\pi}{2} \\ -\cos x, & -\frac{\pi}{2} < x \leq 0 \\ x - 1, & 0 < x \leq 1 \\ \log x, & x > 1 \end{cases}$

Continuity at $x = -\frac{\pi}{2}$,

$$f\left(-\frac{\pi}{2}\right) = -\left(-\frac{\pi}{2}\right) - \frac{\pi}{2} = 0$$

$$\text{RHL} = \lim_{h \rightarrow 0} -\cos\left(-\frac{\pi}{2} + h\right) = 0$$

∴ Continuous at $x = -\frac{\pi}{2}$.

Continuity at $x = 0$

$$f(0) = -1$$

$$\text{RHL} = \lim_{h \rightarrow 0} (0 + h) - 1 = -1$$

∴ Continuous at $x = 0$.

Continuity at $x = 1$,

$$f(1) = 0$$

$$\text{RHL} = \lim_{h \rightarrow 0} \log(1 + h) = 0$$

∴ Continuous at $x = 1$

$$f'(x) = \begin{cases} -1, & x \leq -\frac{\pi}{2} \\ \sin x, & -\frac{\pi}{2} < x \leq 0 \\ 1, & 0 < x \leq 1 \\ \frac{1}{x}, & x > 1 \end{cases}$$

Differentiable at $x=0$, LHD = 0, RHD = 1

∴ Not differentiable at $x=0$

Differentiable at $x=1$, LHD = 1, RHD = 1

∴ Differentiable at $x=1$.

Also, for $x = -\frac{3}{2}$

$$\Rightarrow f(x) = -x - \frac{\pi}{2}$$

∴ Differentiable at $x = -\frac{3}{2}$

38. $f(x+y) = f(x) + f(y)$, as $f(x)$ is differentiable at $x=0$.

$$\Rightarrow f'(0) = k \quad \dots(i)$$

$$\begin{aligned} \text{Now, } f'(x) &= \lim_{h \rightarrow 0} \frac{f(x+h) - f(x)}{h} \\ &= \lim_{h \rightarrow 0} \frac{f(x) + f(h) - f(x)}{h} \\ &= \lim_{h \rightarrow 0} \frac{f(h)}{h} \quad \left[\frac{0}{0} \text{ form} \right] \end{aligned}$$

Given, $f(x+y) = f(x) + f(y), \forall x, y$

$$\therefore f(0) = f(0) + f(0),$$

$$\text{when } x = y = 0 \Rightarrow f(0) = 0$$

Using L'Hospital's rule,

$$= \lim_{h \rightarrow 0} \frac{f'(h)}{1} = f'(0) = k \quad \dots(ii)$$

∴ $f'(x) = k$, integrating both sides,

$$f(x) = kx + C, \text{ as } f(0) = 0$$

$$\Rightarrow C = 0 \quad \therefore f(x) = kx$$

∴ $f(x)$ is continuous for all $x \in R$ and $f'(x) = k$, i.e. constant for all $x \in R$.

Hence, (b) and (c) are correct.

39. Here, $f(x) = \min \{1, x^2, x^3\}$ which could be graphically shown as

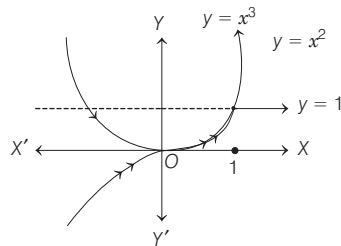

∴ $f(x)$ is continuous for $x \in R$ and not differentiable at $x=1$ due to sharp edge.

Hence, (a) and (d) are correct answers.

40. From the figure,

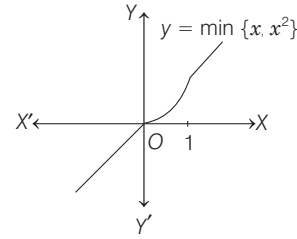

$h(x)$ is continuous all x , but $h(x)$ is not differentiable at two points $x=0$ and $x=1$. (due to sharp edges). Also $h'(x) = 1, \forall x > 1$.

Hence, (a), (c) and (d) is correct answers.

41. Here, $f(x) = \begin{cases} |x-3|, & x \geq 1 \\ x^2 - \frac{3x}{2} + \frac{13}{4}, & x < 1 \end{cases}$

$$\therefore \text{RHL at } x=1, \lim_{h \rightarrow 0} |1+h-3| = 2$$

LHL at $x=1$,

$$\lim_{h \rightarrow 0} \frac{(1-h)^2}{4} - \frac{3(1-h)}{2} + \frac{13}{4} = \frac{1}{4} - \frac{3}{2} + \frac{13}{4} = \frac{14}{4} - \frac{3}{2} = 2$$

∴ $f(x)$ is continuous at $x=1$

$$\text{Again, } f(x) = \begin{cases} -(x-3), & 1 \leq x < 3 \\ (x-3), & x \geq 3 \\ x^2 - \frac{3x}{2} + \frac{13}{4}, & x < 1 \end{cases}$$

$$\therefore f'(x) = \begin{cases} -1, & 1 \leq x < 3 \\ 1, & x \geq 3 \\ \frac{x}{2} - \frac{3}{2}, & x < 1 \end{cases}$$

$$\begin{aligned} \text{RHD at } x=1 &\Rightarrow -1 \\ \therefore \text{LHD at } x=1 &\Rightarrow \frac{1}{2} - \frac{3}{2} = -1 \end{aligned} \left. \vphantom{\begin{aligned} \text{RHD at } x=1 \\ \therefore \text{LHD at } x=1 \end{aligned}} \right\} \text{differentiable at } x=1.$$

$$\begin{aligned} \text{Again, RHD at } x=3 &\Rightarrow 1 \\ \text{LHD at } x=3 &\Rightarrow -1 \end{aligned} \left. \vphantom{\begin{aligned} \text{RHD at } x=3 \\ \text{LHD at } x=3 \end{aligned}} \right\} \text{not differentiable at } x=3.$$

42. We know that, $f(x) = 1 + |\sin x|$ could be plotted as,

$$(1) y = \sin x \quad \dots(i)$$

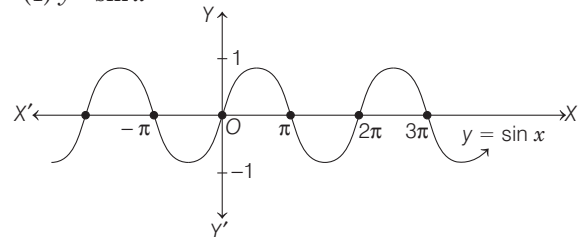

$$(2) y = |\sin x| \quad \dots(ii)$$

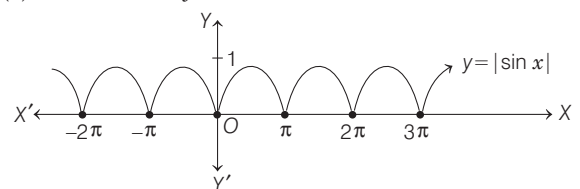

228 Limit, Continuity and Differentiability

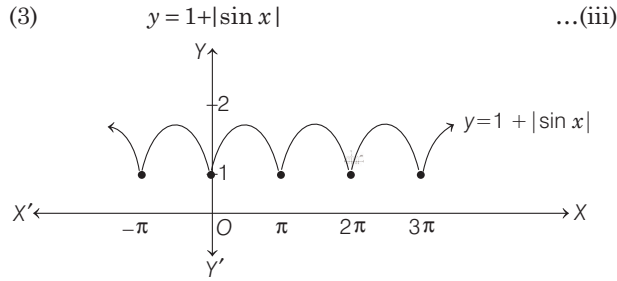

Clearly, $y = 1 + |\sin x|$ is continuous for all x , but not differentiable at infinite number of points..

43. Since, $x + |y| = 2y \Rightarrow \begin{cases} x + y = 2y, & \text{when } y > 0 \\ x - y = 2y, & \text{when } y < 0 \end{cases}$

$\Rightarrow \begin{cases} y = x, & \text{when } y > 0 \Rightarrow x > 0 \\ y = x/3, & \text{when } y < 0 \Rightarrow x < 0 \end{cases}$

which could be plotted as,

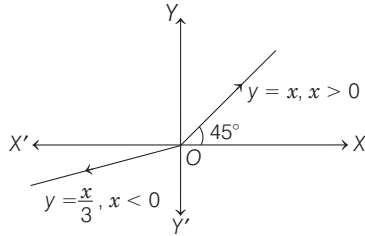

Clearly, y is continuous for all x but not differentiable at $x = 0$.

Also, $\frac{dy}{dx} = \begin{cases} 1, & x > 0 \\ 1/3, & x < 0 \end{cases}$

Thus, $f(x)$ is defined for all x , continuous at $x = 0$, differentiable for all $x \in \mathbb{R} - \{0\}$, $\frac{dy}{dx} = \frac{1}{3}$ for $x < 0$.

44. We have, $\lim_{x \rightarrow 0} \frac{g(x) \cos x - g(0)}{\sin x} \left[\frac{0}{0} \text{ form} \right]$
 $= \lim_{x \rightarrow 0} \frac{g'(x) \cos x - g(x) \sin x}{\cos x} = 0$

Since, $f(x) = g(x) \sin x$

$f'(x) = g'(x) \sin x + g(x) \cos x$

and $f''(x) = g''(x) \sin x + 2g'(x) \cos x - g(x) \sin x$

$\Rightarrow f''(0) = 0$

Thus, $\lim_{x \rightarrow 0} [g(x) \cos x - g(0) \operatorname{cosec} x] = 0 = f''(0)$

\Rightarrow Statement I is true.

Statement II $f'(x) = g'(x) \sin x + g(x) \cos x$

$\Rightarrow f'(0) = g(0)$

Statement II is not a correct explanation of Statement I.

45. A. $x|x|$ is continuous, differentiable and strictly increasing in $(-1, 1)$.
 B. $\sqrt{|x|}$ is continuous in $(-1, 1)$ and not differentiable at $x = 0$.
 C. $x + [x]$ is strictly increasing in $(-1, 1)$ and discontinuous at $x = 0$
 \Rightarrow not differentiable at $x = 0$.
 D. $|x - 1| + |x + 1| = 2$ in $(-1, 1)$
 \Rightarrow The function is continuous and differentiable in $(-1, 1)$.

46. We know, $[x] \in I, \forall x \in \mathbb{R}$.

Therefore, $\sin(\pi[x]) = 0, \forall x \in \mathbb{R}$. By theory, we know that $\sin(\pi[x])$ is differentiable everywhere, therefore (A) \leftrightarrow (p).

Again, $f(x) = \sin\{\pi(x - [x])\}$

Now, $x - [x] = \{x\}$ then $\pi(x - [x]) = \pi\{x\}$

which is not differentiable at $x \in I$.

Therefore, (B) \leftrightarrow (r) is the answer.

47. Given, $F(x) = f(x) \cdot g(x) \cdot h(x)$

On differentiating at $x = x_0$, we get

$F'(x_0) = f'(x_0) \cdot g(x_0) h(x_0) + f(x_0) \cdot g'(x_0) h(x_0) + f(x_0) g(x_0) h'(x_0)$... (i)

where, $F'(x_0) = 21 F(x_0), f'(x_0) = 4f(x_0)$

$g'(x_0) = -7 g(x_0)$ and $h'(x_0) = k h(x_0)$

On substituting in Eq. (i), we get

$21 F(x_0) = 4 f(x_0) g(x_0) h(x_0) - 7 f(x_0) g(x_0) h(x_0) + k f(x_0) g(x_0) h(x_0)$

$\Rightarrow 21 = 4 - 7 + k, [\text{using } F(x_0) = f(x_0) g(x_0) h(x_0)]$

$\therefore k = 24$

48. Given, $f(x) = \begin{cases} \frac{x}{1 + e^{1/x}}, & x \neq 0 \\ 0, & x = 0 \end{cases}$

$\therefore Rf'(0) = f'(0^+) = \lim_{h \rightarrow 0} \frac{\frac{h}{1 + e^{1/h}} - 0}{h}$
 $= \lim_{h \rightarrow 0} \frac{1}{1 + e^{1/h}} = 0$

and $Lf'(0) = f'(0^-) = \lim_{h \rightarrow 0} \frac{\frac{-h}{1 + e^{-1/h}} - 0}{-h}$
 $= \lim_{h \rightarrow 0} \frac{1}{1 + \frac{1}{e^{1/h}}} = \frac{1}{1 + 0} = 1$

$\therefore f'(0^+) = 0$ and $f'(0^-) = 1$

49. Given, $f(x) = \begin{cases} (x-1)^2 \sin \frac{1}{(x-1)} - |x|, & \text{if } x \neq 1 \\ -1, & \text{if } x = 1 \end{cases}$
 $f(x) = \begin{cases} (x-1)^2 \sin \frac{1}{(x-1)} - x, & 0 \leq x - \{1\} \\ (x-1)^2 \sin \frac{1}{(x-1)} + x, & x < 0 \\ -1, & x = 1 \end{cases}$

Here, $f(x)$ is not differentiable at $x = 0$ due to $|x|$.

Thus, $f(x)$ is not differentiable at $x = 0$.

50. It is always true that differential of even function is and odd function.

51. Since, $f(x)$ is differentiable at $x = 0$.

\Rightarrow It is continuous at $x = 0$.

i.e. $\lim_{x \rightarrow 0^+} f(x) = \lim_{x \rightarrow 0^-} f(x) = f(0)$

$$\text{Here, } \lim_{x \rightarrow 0^+} f(x) = \lim_{h \rightarrow 0} \frac{e^{ah/2} - 1}{h} = \lim_{h \rightarrow 0} \frac{e^{ah/2} - 1}{\frac{h}{a}} \cdot \frac{a}{2} = \frac{a}{2}$$

$$\text{Also, } \lim_{x \rightarrow 0^-} f(x) = \lim_{h \rightarrow 0} b \sin^{-1} \left(\frac{c-h}{2} \right) = b \sin^{-1} \frac{c}{2}$$

$$\therefore b \sin^{-1} \frac{c}{2} = \frac{a}{2} = \frac{1}{2}$$

$$\Rightarrow a = 1$$

Also, it is differentiable at $x=0$

$$Rf'(0^+) = Lf'(0^-)$$

$$Rf'(0^+) = \lim_{h \rightarrow 0} \frac{e^{h/2} - 1}{h} \cdot \frac{1}{2} \quad [:\alpha = 1]$$

$$= \lim_{h \rightarrow 0} \frac{2e^{h/2} - 2 - h}{2h^2} = \frac{1}{8}$$

$$\text{and } Lf'(0^-) = \lim_{h \rightarrow 0} \frac{b \sin^{-1} \left(\frac{c-h}{2} \right) - \frac{1}{2}}{-h} = \frac{b/2}{\sqrt{1 - \frac{c^2}{4}}}$$

$$\therefore \frac{b}{\sqrt{4 - c^2}} = \frac{1}{8}$$

$$\Rightarrow 64b^2 = (4 - c^2)$$

$$\Rightarrow a = 1 \quad \text{and} \quad 64b^2 = (4 - c^2)$$

$$\begin{aligned} \text{52. Here, } \lim_{n \rightarrow \infty} \frac{2}{\pi} (n+1) \cos^{-1} \left(\frac{1}{n} \right) - n \\ = \lim_{n \rightarrow \infty} n \left\{ \frac{2}{\pi} \left(1 + \frac{1}{n} \right) \cos^{-1} \left(\frac{1}{n} \right) - 1 \right\} = \lim_{n \rightarrow \infty} nf \left(\frac{1}{n} \right) \end{aligned}$$

$$\text{where, } f \left(\frac{1}{n} \right) = \frac{2}{\pi} \left(1 + \frac{1}{n} \right) \cos^{-1} \left(\frac{1}{n} \right) - 1 = f'(0)$$

$$\left[\text{given, } f'(0) = \lim_{n \rightarrow \infty} nf \left(\frac{1}{n} \right) \right]$$

$$\therefore \lim_{n \rightarrow \infty} \frac{2}{\pi} (n+1) \cos^{-1} \frac{1}{n} - n = f'(0) \quad \dots \text{(i)}$$

$$\text{where, } f(x) = \frac{2}{\pi} (1+x) \cos^{-1} x - 1, \quad f(0) = 0$$

$$\Rightarrow f'(x) = \frac{2}{\pi} \left\{ (1+x) \frac{-1}{\sqrt{1-x^2}} + \cos^{-1} x \right\}$$

$$\Rightarrow f'(0) = \frac{2}{\pi} \left\{ -1 + \frac{\pi}{2} \right\} = 1 - \frac{2}{\pi} \quad \dots \text{(ii)}$$

\(\therefore\) From Eqs. (i) and (ii), we get

$$\lim_{n \rightarrow \infty} \frac{2}{\pi} (n+1) \cos^{-1} \left(\frac{1}{n} \right) - n = 1 - \frac{2}{\pi}$$

$$\text{53. Since, } g(x) \text{ is continuous at } x = \alpha \Rightarrow \lim_{x \rightarrow \alpha} g(x) = g(\alpha)$$

$$\text{and } f(x) - f(\alpha) = g(x)(x - \alpha), \quad \forall x \in R \quad [\text{given}]$$

$$\Rightarrow \frac{f(x) - f(\alpha)}{(x - \alpha)} = g(x)$$

$$\Rightarrow \lim_{x \rightarrow \alpha} \frac{f(x) - f(\alpha)}{x - \alpha} = \lim_{x \rightarrow \alpha} g(x)$$

$$\Rightarrow f'(\alpha) = \lim_{x \rightarrow \alpha} g(x) \Rightarrow f'(\alpha) = g(\alpha)$$

\(\Rightarrow\) $f(x)$ is differentiable at $x = \alpha$.

Conversely, suppose f is differentiable at α , then

$$\lim_{x \rightarrow \alpha} \frac{f(x) - f(\alpha)}{x - \alpha} \text{ exists finitely.}$$

$$\text{Let } g(x) = \begin{cases} \frac{f(x) - f(\alpha)}{x - \alpha}, & x \neq \alpha \\ f'(\alpha), & x = \alpha \end{cases}$$

$$\text{Clearly, } \lim_{x \rightarrow \alpha} g(x) = f'(\alpha)$$

\(\Rightarrow\) $g(x)$ is continuous at $x = \alpha$.

Hence, $f(x)$ is differentiable at $x = \alpha$, iff $g(x)$ is continuous at $x = \alpha$.

54. It is clear that the given function

$$f(x) = \begin{cases} (1-x), & x < 1 \\ (1-x)(2-x), & 1 \leq x \leq 2 \\ (3-x), & x > 2 \end{cases}$$

continuous and differentiable at all points except possibly at $x = 1$ and 2 .

Continuity at $x = 1$,

$$\text{LHL} = \lim_{x \rightarrow 1^-} f(x) = \lim_{x \rightarrow 1^-} (1-x)$$

$$= \lim_{h \rightarrow 0} [1 - (1-h)] = \lim_{h \rightarrow 0} h = 0$$

$$\text{and } \text{RHL} = \lim_{x \rightarrow 1^+} f(x) = \lim_{x \rightarrow 1^+} (1-x)(2-x)$$

$$= \lim_{h \rightarrow 0} [1 - (1+h)] [2 - (1+h)]$$

$$= \lim_{h \rightarrow 0} -h \cdot (1-h) = 0$$

$$\therefore \text{LHL} = \text{RHL} = f(1) = 0$$

Therefore, f is continuous at $x = 1$

Differentiability at $x = 1$,

$$Lf'(1) = \lim_{h \rightarrow 0} \frac{f(1-h) - f(1)}{-h}$$

$$= \lim_{h \rightarrow 0} \frac{1 - (1-h) - 0}{-h} = \lim_{h \rightarrow 0} \left(\frac{h}{-h} \right) = -1$$

$$\text{and } Rf'(1) = \lim_{h \rightarrow 0} \frac{f(1+h) - f(1)}{h}$$

$$= \lim_{h \rightarrow 0} \frac{[1 - (1+h)] [(2 - (1+h)) - 0]}{h}$$

$$= \lim_{h \rightarrow 0} \frac{-h(1-h)}{h} = \lim_{h \rightarrow 0} (h-1) = -1$$

Since, $L[f'(1)] = Rf'(1)$, therefore f is differentiable at $x = 1$.

Continuity at $x = 2$,

$$\text{LHL} = \lim_{x \rightarrow 2^-} f(x) = \lim_{x \rightarrow 2^-} (1-x)(2-x)$$

$$= \lim_{h \rightarrow 0} [1 - (2-h)] [(2 - (2-h))]$$

$$= \lim_{h \rightarrow 0} (-1+h)h = 0$$

230 Limit, Continuity and Differentiability

$$\begin{aligned} \text{and RHL} &= \lim_{x \rightarrow 2^+} f(x) = \lim_{x \rightarrow 2^+} (3 - x) \\ &= \lim_{h \rightarrow 0} [3 - (2 + h)] \\ &= \lim_{h \rightarrow 0} (1 - h) = 1 \end{aligned}$$

Since, $\text{LHL} \neq \text{RHL}$, therefore f is not continuous at $x = 2$ as such f cannot be differentiable at $x = 2$.

Hence, f is continuous and differentiable at all points except at $x = 2$.

$$55. \text{ Given, } f(x) = \begin{cases} xe^{-\left(\frac{1}{x} + \frac{1}{x}\right)}, & x > 0 \\ xe^{-\left(-\frac{1}{x} + \frac{1}{x}\right)}, & x < 0 \\ 0, & x = 0 \end{cases}$$

$$= \begin{cases} xe^{\frac{2}{x}}, & x > 0 \\ x, & x < 0 \\ 0, & x = 0 \end{cases}$$

(i) To check continuity at $x = 0$,

$$\begin{aligned} \text{LHL (at } x = 0) &= \lim_{h \rightarrow 0} -h = 0 \\ \text{RHL} &= \lim_{h \rightarrow 0} \frac{h}{e^{2/h}} = 0 \end{aligned}$$

$$\text{Also, } f(0) = 0$$

$\therefore f(x)$ is continuous at $x = 0$

(ii) To check differentiability at $x = 0$,

$$\begin{aligned} L f'(0) &= \lim_{h \rightarrow 0} \frac{f(0 - h) - f(0)}{-h} \\ &= \lim_{h \rightarrow 0} \frac{(0 - h) - 0}{-h} = 1 \\ R f'(0) &= \lim_{h \rightarrow 0} \frac{f(0 + h) - f(0)}{h} \\ &= \lim_{h \rightarrow 0} \frac{he^{-2/h} - 0}{h} = 0 \end{aligned}$$

$\therefore f(x)$ is not differentiable at $x = 0$.

$$56. \text{ Given, } f\left(\frac{x+y}{2}\right) = \frac{f(x) + f(y)}{2}, \forall x, y \in R$$

On putting $y = 0$, we get

$$f\left(\frac{x}{2}\right) = \frac{f(x) + f(0)}{2} = \frac{1}{2}[1 + f(x)] \quad [\because f(0) = 1]$$

$$\Rightarrow 2f\left(\frac{x}{2}\right) = f(x) + 1$$

$$\Rightarrow f(x) = 2f\left(\frac{x}{2}\right) - 1, \forall x, y \in R \quad \dots(i)$$

Since, $f'(0) = -1$, we get

$$\lim_{h \rightarrow 0} \frac{f(0+h) - f(0)}{h} = -1$$

$$\Rightarrow \lim_{h \rightarrow 0} \frac{f(h) - 1}{h} = -1 \quad \dots(ii)$$

$$\begin{aligned} \text{Again, } f'(x) &= \lim_{h \rightarrow 0} \frac{f(x+h) - f(x)}{h} \\ &= \lim_{h \rightarrow 0} \frac{f\left(\frac{2x+2h}{2}\right) - f(x)}{h} \\ &= \lim_{h \rightarrow 0} \frac{f(2x) + f(2h) - f(x)}{2} \\ &= \lim_{h \rightarrow 0} \frac{\frac{1}{2} \left[2f\left(\frac{2x}{2}\right) - 1 + 2f\left(\frac{2h}{2}\right) - 1 \right] - f(x)}{h} \\ &= \lim_{h \rightarrow 0} \frac{\frac{1}{2} [2f(x) - 1 + 2f(h) - 1] - f(x)}{h} \quad [\text{from Eq. (i)}] \\ &= \lim_{h \rightarrow 0} \frac{f(x) + f(h) - 1 - f(x)}{h} \\ &= \lim_{h \rightarrow 0} \frac{f(h) - 1}{h} = -1 \quad [\text{from Eq. (ii)}] \end{aligned}$$

$$\therefore f'(x) = -1, \forall x \in R$$

$$\Rightarrow \int f'(x) dx = \int -1 dx$$

$$\Rightarrow f(x) = -x + k, \text{ where, } k \text{ is a constant.}$$

$$\text{But } f(0) = 1,$$

$$\text{therefore } f(0) = -0 + k$$

$$\Rightarrow 1 = k$$

$$\Rightarrow f(x) = 1 - x, \forall x \in R \Rightarrow f(2) = -1$$

57. We have, $f(x+y) = f(x) \cdot f(y), \forall x, y \in R$.

$$\begin{aligned} \therefore f(0) &= f(0) \cdot f(0) \Rightarrow f(0) \{f(0) - 1\} = 0 \\ \Rightarrow f(0) &= 1 \quad [\because f(0) \neq 0] \end{aligned}$$

$$\text{Since, } f'(0) = 2 \Rightarrow \lim_{h \rightarrow 0} \frac{f(0+h) - f(0)}{h} = 2$$

$$\Rightarrow \lim_{h \rightarrow 0} \frac{f(h) - 1}{h} = 2 \quad [\because f(0) = 1] \quad \dots(i)$$

$$\begin{aligned} \text{Also, } f'(x) &= \lim_{h \rightarrow 0} \frac{f(x+h) - f(x)}{h} \\ &= \lim_{h \rightarrow 0} \frac{f(x) \cdot f(h) - f(x)}{h}, \\ & \quad [\text{using, } f(x+y) = f(x) \cdot f(y)] \\ &= f(x) \left\{ \lim_{h \rightarrow 0} \frac{f(h) - 1}{h} \right\} \end{aligned}$$

$$\therefore f'(x) = 2f(x) \quad [\text{from Eq. (i)}]$$

$$\Rightarrow \frac{f'(x)}{f(x)} = 2$$

On integrating both sides between 0 to x , we get

$$\int_0^x \frac{f'(x)}{f(x)} dx = 2x$$

$$\Rightarrow \log_e |f(x)| - \log_e |f(0)| = 2x$$

$$\Rightarrow \log_e |f(x)| = 2x \quad [\because f(0) = 1]$$

$$\Rightarrow \log_e |f(0)| = 0$$

$$\Rightarrow f(x) = e^{2x}$$

$$58. \quad y = [x] + |1-x|, -1 \leq x \leq 3$$

$$\Rightarrow y = \begin{cases} -1+1-x, & -1 \leq x < 0 \\ 0+1-x, & 0 \leq x < 1 \\ 1+x-1, & 1 \leq x < 2 \\ 2+x-1, & 2 \leq x \leq 3 \end{cases}$$

$$\Rightarrow y = \begin{cases} -x, & -1 \leq x < 0 \\ 1-x, & 0 \leq x < 1 \\ +x, & 1 \leq x < 2 \\ x+1, & 2 \leq x < 3 \end{cases}$$

which could be shown as,

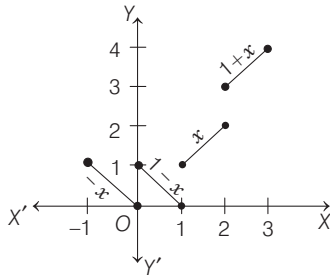

Clearly, from above figure, y is not continuous and not differentiable at $x = \{0, 1, 2\}$.

$$59. \quad \text{Since, } |f(y) - f(x)|^2 \leq (x-y)^3$$

$$\Rightarrow \frac{|f(y) - f(x)|^2}{(y-x)^2} \leq (x-y)$$

$$\Rightarrow \left| \frac{f(y) - f(x)}{y-x} \right|^2 \leq x-y \quad \dots(i)$$

$$\Rightarrow \lim_{y \rightarrow x} \left| \frac{f(y) - f(x)}{y-x} \right|^2 \leq \lim_{y \rightarrow x} (x-y)$$

$$\Rightarrow |f'(x)|^2 \leq 0$$

which is only possible, if $|f'(x)| = 0$

$$\therefore f'(x) = 0$$

or $f'(x) = \text{Constant}$

$$60. \quad \text{Since, } f(-x) = f(x)$$

$\therefore f(x)$ is an even function.

$$\therefore f'(0) = \lim_{h \rightarrow 0} \frac{f(0+h) - f(0)}{h}$$

$$= \lim_{h \rightarrow 0} \frac{f(0-h) - f(0)}{-h} \quad [\because f(-h) = f(h)]$$

Since, $f'(0)$ exists.

$$\therefore Rf'(0) = Lf'(0)$$

$$\Rightarrow \lim_{h \rightarrow 0} \frac{f(h) - f(0)}{h} = \lim_{h \rightarrow 0} \frac{f(h) - f(0)}{-h}$$

$$\Rightarrow 2 \lim_{h \rightarrow 0} \frac{f(h) - f(0)}{h} = 0$$

$$\Rightarrow \lim_{h \rightarrow 0} \frac{f(h) - f(0)}{h} = 0$$

$$\therefore f'(0) = 0$$

$$61. \quad \text{Given that, } f(x) = \begin{cases} -1, & -2 \leq x \leq 0 \\ (x-1), & 0 < x \leq 2 \end{cases}$$

Since, $x \in [-2, 2]$. Therefore, $|x| \in [0, 2]$

$$\Rightarrow f(|x|) = |x| - 1, \forall x \in [-2, 2]$$

$$\Rightarrow f(|x|) = \begin{cases} x-1, & 0 \leq x \leq 2 \\ -x-1, & -2 \leq x \leq 0 \end{cases}$$

Also, $|f(x)| = \begin{cases} 1, & -2 \leq x < 0 \\ 1-x, & 0 \leq x < 1 \\ x-1, & 1 \leq x \leq 2 \end{cases}$

Also, $g(x) = f(|x|) + |f(x)|$

$$= \begin{cases} -x-1+1, & -2 \leq x \leq 0 \\ x-1+1-x, & 0 \leq x < 1 \\ x-1+x-1, & 1 \leq x \leq 2 \end{cases}$$

$$g(x) = \begin{cases} -x, & -2 \leq x \leq 0 \\ 0, & 0 \leq x < 1 \\ 2(x-1), & 1 \leq x \leq 2 \end{cases}$$

$$\therefore g'(x) = \begin{cases} -1, & -2 \leq x \leq 0 \\ 0, & 0 \leq x < 1 \\ 2, & 1 \leq x \leq 2 \end{cases}$$

\therefore RHD (at $x=1$) = 2, LHD (at $x=1$) = 0

$\Rightarrow g(x)$ is not differentiable at $x=1$.

Also, RHD (at $x=0$) = 0, LHD (at $x=0$) = -1

$\Rightarrow g(x)$ is not differentiable at $x=0$.

Hence, $g(x)$ is differentiable for all $x \in (-2, 2) - \{0, 1\}$

$$62. \quad \text{Given, } f(x) = x^3 - x^2 - x + 1$$

$$\Rightarrow f'(x) = 3x^2 - 2x - 1 = (3x+1)(x-1)$$

$\therefore f(x)$ is increasing for $x \in (-\infty, -1/3) \cup (1, \infty)$ and decreasing for $x \in (-1/3, 1)$

Also, given $g(x) = \begin{cases} \max\{f(t); 0 \leq t \leq x\}, & 0 \leq x \leq 1 \\ 3-x, & 1 < x \leq 2 \end{cases}$

$$\Rightarrow g(x) = \begin{cases} f(x), & 0 \leq x \leq 1 \\ 3-x, & 1 < x \leq 2 \end{cases}$$

$$\Rightarrow g(x) = \begin{cases} x^3 - x^2 - x + 1, & 0 \leq x \leq 1 \\ 3-x, & 1 < x \leq 2 \end{cases}$$

At $x=1$,

$$\text{RHL} = \lim_{x \rightarrow 1^-} (3-x) = 2$$

and $\text{LHL} = \lim_{x \rightarrow 1^+} (x^3 - x^2 - x + 1) = 0$

\therefore It is discontinuous at $x=1$.

Also, $g'(x) = \begin{cases} 3x^2 - 2x - 1, & 0 \leq x \leq 1 \\ -1, & 1 < x \leq 2 \end{cases}$

$$\Rightarrow g'(1^+) = -1$$

and $g'(1^-) = 3 - 2 - 1 = 0$

$\therefore g(x)$ is continuous for all $x \in (0, 2) - \{1\}$ and $g(x)$ is differentiable for all $x \in (0, 2) - \{1\}$.

232 Limit, Continuity and Differentiability

63. Given that, $f(x) = \begin{cases} \frac{x-1}{2x^2-7x+5}, & \text{when } x \neq 1 \\ -\frac{1}{3}, & \text{when } x = 1 \end{cases}$

$$\begin{aligned} \text{RHD} &= \lim_{h \rightarrow 0} \frac{f(1+h) - f(1)}{h} \\ &= \lim_{h \rightarrow 0} \left[\frac{1+h-1}{2(1+h)^2-7(1+h)+5} - \left(-\frac{1}{3}\right) \right] \\ &= \lim_{h \rightarrow 0} \left[\frac{3h+2(1+h)^2-7(1+h)+5}{3h\{2(1+h)^2-7(1+h)+5\}} \right] \\ &= \lim_{h \rightarrow 0} \left(\frac{2h^2}{3h(-3h+2h^2)} \right) = -\frac{2}{9} \\ \text{LHD} &= \lim_{h \rightarrow 0} \frac{f(1-h) - f(1)}{-h} \\ &= \lim_{h \rightarrow 0} \left[\frac{1-h-1}{2(1-h)^2-7(1-h)+5} - \left(-\frac{1}{3}\right) \right] \\ &= \lim_{h \rightarrow 0} \frac{-3h+2(1+h^2-2h)-7(1-h)+5}{-3h[2(1-h)^2-7(1-h)+5]} \\ &= \lim_{h \rightarrow 0} \frac{2h^2}{-3h(2h^2+3h)} = -\frac{2}{9} \therefore \text{LHD} = \text{RHD} \end{aligned}$$

Hence, required value of $f'(1) = -\frac{2}{9}$.

64. Given, $f(x) = x \tan^{-1} x$

Using first principle,

$$\begin{aligned} f'(1) &= \lim_{h \rightarrow 0} \left[\frac{f(1+h) - f(1)}{h} \right] \\ &= \lim_{h \rightarrow 0} \left[\frac{(1+h) \tan^{-1}(1+h) - \tan^{-1}(1)}{h} \right] \\ &= \lim_{h \rightarrow 0} \left[\frac{\tan^{-1}(1+h) - \tan^{-1}(1)}{h} + \frac{h \tan^{-1}(1+h)}{h} \right] \\ &= \lim_{h \rightarrow 0} \left[\frac{1}{h} \tan^{-1} \left(\frac{h}{2+h} \right) + \tan^{-1}(1+h) \right] \\ &= \lim_{h \rightarrow 0} \left[\frac{\tan^{-1} \left(\frac{h}{2+h} \right)}{(2+h) \cdot \frac{h}{2+h}} \right] + \frac{\pi}{4} \\ &= \lim_{h \rightarrow 0} \frac{1}{2+h} \left(\frac{\tan^{-1} \left(\frac{h}{2+h} \right)}{\frac{h}{2+h}} \right) + \frac{\pi}{4} = \frac{1}{2} + \frac{\pi}{4} \end{aligned}$$

65. The given functions $f: (-1, 1) \rightarrow R$ and $g: (-1, 1) \rightarrow (-1, 1)$ be defined by

$$f(x) = |2x-1| + |2x+1| \text{ and } g(x) = x - [x].$$

As, we know the composite function $(f \circ g)(x)$ is discontinuous at the points, where $g(x)$ is discontinuous for given domain. And, since $g(x)$ is discontinuous at $x=0$ lies in interval $(-1, 1)$, so value of $c = 1$.

And, since $(f \circ g)(x)$ is not differentiable at the point where $g(x)$ is not differentiable as well as at those points also where $g(x)$ attains the values so that $f(g(x))$ is non-differentiable.

Since $g(x)$ is not continuous at $x=0 \in (-1, 1)$ so $f \circ g(x)$ is not differentiable and as $f(x) = |2x-1| + |2x+1|$ is not differentiable at $x = -1/2$ and $1/2$, so $(f \circ g)(x)$ is not differentiable for those x , for which $g(x) = -1/2$ or $1/2$.

But $g(x) \geq 0$, so $g(x)$ can be $1/2$ only and for $x = -1/2$ and $1/2$, $g(x) = \frac{1}{2}$.

So, $(f \circ g)(x)$ is not differentiable at $x = -1/2, 0, 1/2$, therefore value of $d = 3$

$$\therefore c + d = 1 + 3 = 4.$$

66. $g(x) = \int_x^{\frac{\pi}{2}} (f'(t) \operatorname{cosec} t - \cot t \operatorname{cosec} t f(t)) dt$

$$\therefore g(x) = f\left(\frac{\pi}{2}\right) \operatorname{cosec} \frac{\pi}{2} - f(x) \operatorname{cosec} x$$

$$\Rightarrow g(x) = 3 - \frac{f(x)}{\sin x}$$

$$\begin{aligned} \lim_{x \rightarrow 0} g(x) &= \lim_{x \rightarrow 0} \left(\frac{3 \sin x - f(x)}{\sin x} \right) \\ &= \lim_{x \rightarrow 0} \frac{3 \cos x - f'(x)}{\cos x} \\ &= \frac{3-1}{1} = 2 \end{aligned}$$

67. PLAN

- In these type of questions, we draw the graph of the function.
- The points at which the curve taken a sharp turn, are the points of non-differentiability.

Curve of $f(x)$ and $g(x)$ are

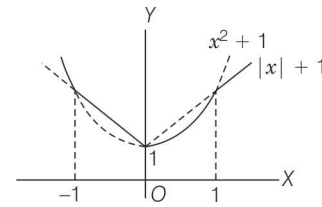

$h(x)$ is not differentiable at $x = \pm 1$ and 0 .

As, $h(x)$ take sharp turns at $x = \pm 1$ and 0 .

Hence, number of points of non-differentiability of $h(x)$ is 3.

68. Let $p(x) = ax^4 + bx^3 + cx^2 + dx + e$

$$\Rightarrow p'(x) = 4ax^3 + 3bx^2 + 2cx + d$$

$$\therefore p'(1) = 4a + 3b + 2c + d = 0 \quad \dots (i)$$

$$\text{and } p'(2) = 32a + 12b + 4c + d = 0 \quad \dots (ii)$$

Since, $\lim_{x \rightarrow 0} \left(1 + \frac{p(x)}{x^2} \right) = 2$ [given]

$$\therefore \lim_{x \rightarrow 0} \frac{ax^4 + bx^3 + (c+1)x^2 + dx + e}{x^2} = 2$$

$$\Rightarrow c + 1 = 2, \quad d = 0, \quad e = 0$$

$$\Rightarrow c = 1$$

From Eqs. (i) and (ii), we get

$$4a + 3b = -2$$

and

$$32a + 12b = -4$$

$$\Rightarrow a = \frac{1}{4} \text{ and } b = -1.$$

$$\therefore p(x) = \frac{x^4}{4} - x^3 + x^2$$

$$\Rightarrow p(2) = \frac{16}{4} - 8 + 4$$

$$\Rightarrow p(2) = 0$$

Topic 8 Differentiation

1. It is given

$$(a + \sqrt{2}b \cos x)(a - \sqrt{2}b \cos y) = a^2 - b^2$$

where $a > b > 0$,

On differentiating w.r.t. 'y', we get

$$\begin{aligned} & (a - \sqrt{2}b \cos y) \left(0 + \sqrt{2}b (-\sin x) \frac{dx}{dy} \right) \\ & \quad + (a + \sqrt{2}b \cos x)(0 - \sqrt{2}b (-\sin y)) = 0 \\ \Rightarrow & (a - \sqrt{2}b \cos y) \left(-\sqrt{2}b (\sin x) \frac{dx}{dy} \right) \\ & \quad + \sqrt{2}b (\sin y)(a + \sqrt{2}b \cos x) = 0 \end{aligned}$$

At $\left(\frac{\pi}{4}, \frac{\pi}{4}\right)$, we get

$$\begin{aligned} & (a - b) \left(-b \frac{dx}{dy} \right) + b(a + b) = 0 \\ \Rightarrow & \frac{dx}{dy} = \frac{a + b}{a - b} \end{aligned}$$

Hence, option (b) is correct.

2. We know,

$$(1 + x)^n = {}^nC_0 + {}^nC_1 x + {}^nC_2 x^2 + \dots + {}^nC_n x^n$$

On differentiating both sides w.r.t. x, we get

$$n(1 + x)^{n-1} = {}^nC_1 + 2 {}^nC_2 x + \dots + n {}^nC_n x^{n-1}$$

On multiplying both sides by x, we get

$$n x(1 + x)^{n-1} = {}^nC_1 x + 2 {}^nC_2 x^2 + \dots + n {}^nC_n x^n$$

Again on differentiating both sides w.r.t. x, we get

$$\begin{aligned} & n [(1 + x)^{n-1} + (n - 1) x (1 + x)^{n-2}] \\ & \quad = {}^nC_1 + 2^2 {}^nC_2 x + \dots + n^2 {}^nC_n x^{n-1} \end{aligned}$$

Now putting $x = 1$ in both sides, we get

$$\begin{aligned} & {}^nC_1 + (2^2) {}^nC_2 + (3^2) {}^nC_3 + \dots + (n^2) {}^nC_n \\ & \quad = n(2^{n-1} + (n - 1) 2^{n-2}) \end{aligned}$$

For $n = 20$, we get

$$\begin{aligned} & {}^{20}C_1 + (2^2) {}^{20}C_2 + (3^2) {}^{20}C_3 + \dots + (20)^2 {}^{20}C_{20} \\ & \quad = 20(2^{19} + (19) 2^{18}) \\ & \quad = 20(2 + 19) 2^{18} = 420(2^{18}) \\ & \quad = A(2^B) \text{ (given)} \end{aligned}$$

On comparing, we get

$$(A, B) = (420, 18)$$

3. Let $f(x) = \tan^{-1} \left(\frac{\sin x - \cos x}{\sin x + \cos x} \right) = \tan^{-1} \left(\frac{\tan x - 1}{\tan x + 1} \right)$
 [dividing numerator and denominator by $\cos x > 0, x \in \left(0, \frac{\pi}{2}\right)$]

$$\begin{aligned} & = \tan^{-1} \left(\frac{\tan x - \tan \frac{\pi}{4}}{1 + \left(\tan \frac{\pi}{4}\right)(\tan x)} \right) = \tan^{-1} \left[\tan \left(x - \frac{\pi}{4} \right) \right] \\ & \quad \left[\because \frac{\tan A - \tan B}{1 + \tan A \tan B} = \tan(A - B) \right] \end{aligned}$$

Since, it is given that $x \in \left(0, \frac{\pi}{2}\right)$, so

$$x - \frac{\pi}{4} \in \left(-\frac{\pi}{4}, \frac{\pi}{4}\right)$$

Also, for $\left(x - \frac{\pi}{4}\right) \in \left(-\frac{\pi}{4}, \frac{\pi}{4}\right)$,

Then,

$$f(x) = \tan^{-1} \left(\tan \left(x - \frac{\pi}{4} \right) \right) = x - \frac{\pi}{4}$$

$$\left[\because \tan^{-1} \tan \theta = \theta, \text{ for } \theta \in \left(-\frac{\pi}{2}, \frac{\pi}{2}\right) \right]$$

Now, derivative of $f(x)$ w.r.t. $\frac{x}{2}$ is

$$\begin{aligned} \frac{d(f(x))}{d(x/2)} &= 2 \frac{df(x)}{dx} \\ &= 2 \times \frac{d}{dx} \left(x - \frac{\pi}{4} \right) = 2 \end{aligned}$$

4. **Key Idea** Differentiating the given equation twice w.r.t. 'x'.

Given equation is

$$e^y + xy = e \quad \dots(i)$$

On differentiating both sides w.r.t. x, we get

$$e^y \frac{dy}{dx} + x \frac{dy}{dx} + y = 0 \quad \dots(ii)$$

$$\Rightarrow \frac{dy}{dx} = - \left(\frac{y}{e^y + x} \right) \quad \dots(iii)$$

Again differentiating Eq. (ii) w.r.t. 'x', we get

$$e^y \frac{d^2y}{dx^2} + e^y \left(\frac{dy}{dx} \right)^2 + x \frac{d^2y}{dx^2} + \frac{dy}{dx} + \frac{dy}{dx} = 0 \quad \dots(iv)$$

Now, on putting $x = 0$ in Eq. (i), we get

$$e^y = e^1$$

$$\Rightarrow y = 1$$

On putting $x = 0, y = 1$ in Eq. (iii), we get

$$\frac{dy}{dx} = - \frac{1}{e + 0} = - \frac{1}{e}$$

Now, on putting $x = 0, y = 1$ and $\frac{dy}{dx} = - \frac{1}{e}$ in

Eq. (iv), we get

234 Limit, Continuity and Differentiability

$$e^1 \frac{d^2y}{dx^2} + e^1 \left(-\frac{1}{e}\right)^2 + 0 \left(\frac{d^2y}{dx^2}\right) + \left(-\frac{1}{e}\right) + \left(-\frac{1}{e}\right) = 0$$

$$\Rightarrow \left. \frac{d^2y}{dx^2} \right|_{(0,1)} = \frac{1}{e^2}$$

$$\text{So, } \left(\frac{dy}{dx}, \frac{d^2y}{dx^2} \right) \text{ at } (0, 1) \text{ is } \left(-\frac{1}{e}, \frac{1}{e^2} \right)$$

5. Let $y = f(f(f(x))) + (f(x))^2$

On differentiating both sides w.r.t. x , we get

$$\frac{dy}{dx} = f'(f(f(x))) \cdot f'(f(x)) \cdot f'(x) + 2f(x)f'(x)$$

[by chain rule]

$$\text{So, } \left. \frac{dy}{dx} \right|_{\text{at } x=1} = f'(f(f(1))) \cdot f'(f(1)) \cdot f'(1) + 2f(1)f'(1)$$

$$\therefore \left. \frac{dy}{dx} \right|_{x=1} = f'(f(1)) \cdot f'(1) \cdot (3) + 2(1)(3)$$

$$[\because f(1) = 1 \text{ and } f'(1) = 3]$$

$$= f'(1) \cdot (3) \cdot (3) + 6$$

$$= (3 \times 9) + 6 = 27 + 6 = 33$$

6. Given expression is

$$2y = \left(\cot^{-1} \left(\frac{\sqrt{3} \cos x + \sin x}{\cos x - \sqrt{3} \sin x} \right) \right)^2 = \left(\cot^{-1} \left(\frac{\sqrt{3} \cot x + 1}{\cot x - \sqrt{3}} \right) \right)^2$$

[dividing each term of numerator and denominator by $\sin x$]

$$= \left(\cot^{-1} \left(\frac{\cot \frac{\pi}{6} \cot x + 1}{\cot x - \cot \frac{\pi}{6}} \right) \right)^2 \quad \left[\because \cot \frac{\pi}{6} = \sqrt{3} \right]$$

$$= \left(\cot^{-1} \left(\cot \left(\frac{\pi}{6} - x \right) \right) \right)^2 \quad \left[\because \cot(A - B) = \frac{\cot A \cot B + 1}{\cot B - \cot A} \right]$$

$$= \begin{cases} \left(\frac{\pi}{6} - x \right)^2, & 0 < x < \frac{\pi}{6} \\ \left(\pi + \left(\frac{\pi}{6} - x \right) \right)^2, & \frac{\pi}{6} < x < \frac{\pi}{2} \end{cases}$$

$$\left[\because \cot^{-1}(\cot \theta) = \begin{cases} \pi + \theta, & -\pi < \theta < 0 \\ \theta, & 0 < \theta < \pi \\ \theta - \pi, & \pi < \theta < 2\pi \end{cases} \right]$$

$$\Rightarrow 2y = \begin{cases} \left(\frac{\pi}{6} - x \right)^2, & 0 < x < \frac{\pi}{6} \\ \left(\frac{7\pi}{6} - x \right)^2, & \frac{\pi}{6} < x < \frac{\pi}{2} \end{cases}$$

$$\Rightarrow 2 \frac{dy}{dx} = \begin{cases} 2 \left(\frac{\pi}{6} - x \right) (-1), & 0 < x < \frac{\pi}{6} \\ 2 \left(\frac{7\pi}{6} - x \right) (-1), & \frac{\pi}{6} < x < \frac{\pi}{2} \end{cases}$$

$$\Rightarrow \frac{dy}{dx} = \begin{cases} x - \frac{\pi}{6}, & 0 < x < \frac{\pi}{6} \\ x - \frac{7\pi}{6}, & \frac{\pi}{6} < x < \frac{\pi}{2} \end{cases}$$

7. Given equation is

$$(2x)^{2y} = 4 \cdot e^{2x-2y} \quad \dots (i)$$

On applying 'log_e' both sides, we get

$$\log_e (2x)^{2y} = \log_e 4 + \log_e e^{2x-2y}$$

$$2y \log_e (2x) = \log_e (2)^2 + (2x-2y)$$

$$[\because \log_e n^m = m \log_e n \text{ and } \log_e e^{f(x)} = f(x)]$$

$$\Rightarrow (2 \log_e (2x) + 2)y = 2x + 2 \log_e (2)$$

$$\Rightarrow y = \frac{x + \log_e 2}{1 + \log_e (2x)}$$

On differentiating 'y' w.r.t. 'x', we get

$$\frac{dy}{dx} = \frac{(1 + \log_e (2x))1 - (x + \log_e 2) \frac{2}{2x}}{(1 + \log_e (2x))^2}$$

$$= \frac{1 + \log_e (2x) - 1 - \frac{1}{x} \log_e 2}{(1 + \log_e (2x))^2}$$

$$\text{So, } (1 + \log_e (2x))^2 \frac{dy}{dx} = \left(\frac{x \log_e (2x) - \log_e 2}{x} \right)$$

8. We have, $x \log_e (\log_e x) - x^2 + y^2 = 4$, which can be written as

$$y^2 = 4 + x^2 - x \log_e (\log_e x) \quad \dots (i)$$

Now, differentiating Eq. (i) w.r.t. x , we get

$$2y \frac{dy}{dx} = 2x - x \frac{1}{\log_e x} \cdot \frac{1}{x} - 1 \cdot \log_e (\log_e x)$$

[by using product rule of derivative]

$$\Rightarrow \left(\frac{dy}{dx} \right) = \frac{2x - \frac{1}{\log_e x} - \log_e (\log_e x)}{2y} \quad \dots (ii)$$

Now, at $x = e$, $y^2 = 4 + e^2 - e \log_e (\log_e e)$

[using Eq. (i)]

$$= 4 + e^2 - e \log_e (1) = 4 + e^2 - 0$$

$$= e^2 + 4$$

$$\Rightarrow y = \sqrt{e^2 + 4} \quad [\because y > 0]$$

\therefore At $x = e$ and $y = \sqrt{e^2 + 4}$,

$$\frac{dy}{dx} = \frac{2e - 1 - 0}{2\sqrt{e^2 + 4}} = \frac{2e - 1}{2\sqrt{e^2 + 4}} \quad \text{[using Eq. (ii)]}$$

9. We have,

$$f(x) = x^3 + x^2 f'(1) + x f''(2) + f'''(3)$$

$$\Rightarrow f'(x) = 3x^2 + 2x f'(1) + f''(2) \quad \dots (i)$$

$$\Rightarrow f''(x) = 6x + 2f'(1) \quad \dots (ii)$$

$$\Rightarrow f'''(x) = 6 \quad \dots (iii)$$

$$\Rightarrow f'''(3) = 6$$

Putting $x = 1$ in Eq. (i), we get

$$f'(1) = 3 + 2f'(1) + f''(2) \quad \dots (iv)$$

and putting $x = 2$ in Eq. (ii), we get

$$f''(2) = 12 + 2f'(1) \quad \dots (v)$$

From Eqs. (iv) and (v), we get

$$f'(1) = 3 + 2f'(1) + (12 + 2f'(1))$$

$$\Rightarrow 3f'(1) = -15$$

$$\begin{aligned} \Rightarrow f'(1) &= -5 \\ \Rightarrow f''(2) &= 12 + 2(-5) = 2 \quad [\text{using Eq. (v)}] \\ \therefore f(x) &= x^3 + x^2 f'(1) + x f''(2) + f'''(3) \\ \Rightarrow f(x) &= x^3 - 5x^2 + 2x + 6 \\ \Rightarrow f(2) &= 2^3 - 5(2)^2 + 2(2) + 6 = 8 - 20 + 4 + 6 = -2 \end{aligned}$$

10. We have, $x = 3 \tan t$ and $y = 3 \sec t$

$$\begin{aligned} \text{Clearly, } \frac{dy}{dx} &= \frac{\frac{dy}{dt}}{\frac{dx}{dt}} = \frac{\frac{d}{dt}(3 \sec t)}{\frac{d}{dt}(3 \tan t)} \\ &= \frac{3 \sec t \tan t}{3 \sec^2 t} = \frac{\tan t}{\sec t} = \sin t \end{aligned}$$

$$\begin{aligned} \text{and } \frac{d^2y}{dx^2} &= \frac{d}{dx} \left(\frac{dy}{dx} \right) = \frac{d}{dt} \left(\frac{dy}{dx} \right) \cdot \frac{dt}{dx} \\ &= \frac{\frac{d}{dt} \left(\frac{dy}{dx} \right)}{\frac{dx}{dt}} = \frac{\frac{d}{dt}(\sin t)}{\frac{d}{dt}(3 \tan t)} = \frac{\cos t}{3 \sec^2 t} = \frac{\cos^3 t}{3} \end{aligned}$$

$$\text{Now, } \frac{d^2y}{dx^2} \left(\text{at } t = \frac{\pi}{4} \right) = \frac{\cos^3 \frac{\pi}{4}}{3} = \frac{1}{3(2\sqrt{2})} = \frac{1}{6\sqrt{2}}$$

$$\begin{aligned} 11. \text{ Let } y &= \tan^{-1} \left(\frac{6x\sqrt{x}}{1-9x^3} \right) = \tan^{-1} \left[\frac{2 \cdot (3x^{3/2})}{1 - (3x^{3/2})^2} \right] \\ &= 2 \tan^{-1} (3x^{3/2}) \left[\because 2 \tan^{-1} x = \tan^{-1} \frac{2x}{1-x^2} \right] \\ \therefore \frac{dy}{dx} &= 2 \cdot \frac{1}{1 + (3x^{3/2})^2} \cdot 3 \times \frac{3}{2} (x)^{1/2} = \frac{9}{1 + 9x^3} \cdot \sqrt{x} \\ \therefore g(x) &= \frac{9}{1 + 9x^3} \end{aligned}$$

12. Here, g is the inverse of $f(x)$.

$$\Rightarrow f \circ g(x) = x$$

On differentiating w.r.t. x , we get

$$\begin{aligned} f' \{g(x)\} \times g'(x) &= 1 \Rightarrow g'(x) = \frac{1}{f'(g(x))} \\ &= \frac{1}{1 + \{g(x)\}^5} \quad \left[\because f'(x) = \frac{1}{1+x^5} \right] \end{aligned}$$

$$\Rightarrow g'(x) = 1 + \{g(x)\}^5$$

13. Given, $y = \sec(\tan^{-1} x)$

$$\text{Let } \tan^{-1} x = \theta$$

$$\Rightarrow x = \tan \theta$$

$$\therefore y = \sec \theta = \sqrt{1+x^2}$$

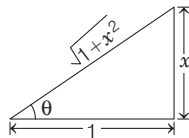

On differentiating w.r.t. x , we get

$$\frac{dy}{dx} = \frac{1}{2\sqrt{1+x^2}} \cdot 2x$$

$$\text{At } x = 1, \quad \frac{dy}{dx} = \frac{1}{\sqrt{2}}$$

14. Since, $f(x) = e^{g(x)} \Rightarrow e^{g(x+1)} = f(x+1) = x f(x) = x e^{g(x)}$

$$\text{and } g(x+1) = \log x + g(x)$$

$$\text{i.e. } g(x+1) - g(x) = \log x \quad \dots (i)$$

Replacing x by $x - \frac{1}{2}$, we get

$$g\left(x + \frac{1}{2}\right) - g\left(x - \frac{1}{2}\right) = \log\left(x - \frac{1}{2}\right) = \log(2x-1) - \log 2$$

$$\therefore g''\left(x + \frac{1}{2}\right) - g''\left(x - \frac{1}{2}\right) = \frac{-4}{(2x-1)^2} \quad \dots (ii)$$

On substituting, $x = 1, 2, 3, \dots, N$ in Eq. (ii) and adding, we get

$$g''\left(N + \frac{1}{2}\right) - g''\left(\frac{1}{2}\right) = -4 \left\{ 1 + \frac{1}{9} + \frac{1}{25} + \dots + \frac{1}{(2N-1)^2} \right\}$$

15. Since, $\frac{dx}{dy} = \frac{1}{dy/dx} = \left(\frac{dy}{dx}\right)^{-1}$

$$\Rightarrow \frac{d}{dy} \left(\frac{dx}{dy} \right) = \frac{d}{dx} \left(\frac{dy}{dx} \right)^{-1} \frac{dx}{dy}$$

$$\Rightarrow \frac{d^2x}{dy^2} = - \left(\frac{d^2y}{dx^2} \right) \left(\frac{dy}{dx} \right)^{-2} \left(\frac{dx}{dy} \right) = - \left(\frac{d^2y}{dx^2} \right) \left(\frac{dy}{dx} \right)^{-3}$$

16. Since, $f''(x) = -f(x)$

$$\Rightarrow \frac{d}{dx} \{f'(x)\} = -f(x)$$

$$\Rightarrow g'(x) = -f(x) \quad [\because g(x) = f'(x), \text{ given}] \dots (i)$$

$$\text{Also, } F(x) = \left\{ f\left(\frac{x}{2}\right) \right\}^2 + \left\{ g\left(\frac{x}{2}\right) \right\}^2$$

$$\begin{aligned} \Rightarrow F'(x) &= 2 \left(f\left(\frac{x}{2}\right) \right) \cdot f'\left(\frac{x}{2}\right) \cdot \frac{1}{2} \\ &\quad + 2 \left(g\left(\frac{x}{2}\right) \right) \cdot g'\left(\frac{x}{2}\right) \cdot \frac{1}{2} = 0 \quad [\text{from Eq.(i)}] \end{aligned}$$

$$\therefore F(x) \text{ is constant } \Rightarrow F(10) = F(5) = 5$$

17. Let, $g(x) = f(x) - x^2$

$\Rightarrow g(x)$ has atleast 3 real roots which are $x = 1, 2, 3$

[by mean value theorem]

$\Rightarrow g'(x)$ has atleast 2 real roots in $x \in (1, 3)$

$\Rightarrow g''(x)$ has atleast 1 real roots in $x \in (1, 3)$

$\Rightarrow f''(x) - 2 \cdot 1 = 0$, for atleast 1 real root in $x \in (1, 3)$

$\Rightarrow f''(x) = 2$, for atleast one root in $x \in (1, 3)$

18. Given that, $\log(x+y) = 2xy$

... (i)

$$\therefore \text{At } x = 0, \Rightarrow \log(y) = 0 \Rightarrow y = 1$$

$$\therefore \text{To find } \frac{dy}{dx} \text{ at } (0, 1)$$

On differentiating Eq. (i) w.r.t. x , we get

$$\frac{1}{x+y} \left(1 + \frac{dy}{dy} \right) = 2x \frac{dy}{dx} + 2y \cdot 1$$

$$\Rightarrow \frac{dy}{dx} = \frac{2y(x+y) - 1}{1 - 2(x+y)x} \Rightarrow \left(\frac{dy}{dx} \right)_{(0,1)} = 1$$

236 Limit, Continuity and Differentiability

19. Given, $x^2 + y^2 = 1$

On differentiating w.r.t. x , we get

$$2x + 2yy' = 0 \Rightarrow x + yy' = 0.$$

Again, differentiating w.r.t. x , we get

$$1 + y'y' + yy'' = 0 \Rightarrow 1 + (y')^2 + yy'' = 0$$

20. Given, $f(x) = \begin{vmatrix} x^3 & \sin x & \cos x \\ 6 & -1 & 0 \\ p & p^2 & p^3 \end{vmatrix}$

On differentiating w.r.t. x , we get

$$f'(x) = \begin{vmatrix} 3x^2 & \cos x & -\sin x \\ 6 & -1 & 0 \\ p & p^2 & p^3 \end{vmatrix} + \begin{vmatrix} x^3 & \sin x & \cos x \\ 0 & 0 & 0 \\ p & p^2 & p^3 \end{vmatrix} + \begin{vmatrix} x^3 & \sin x & \cos x \\ 6 & -1 & 0 \\ 0 & 0 & 0 \end{vmatrix}$$

$$\Rightarrow f'(x) = \begin{vmatrix} 3x^2 & \cos x & -\sin x \\ 6 & -1 & 0 \\ p & p^2 & p^3 \end{vmatrix}$$

$$\Rightarrow f''(x) = \begin{vmatrix} 6x & -\sin x & -\cos x \\ 6 & -1 & 0 \\ p & p^2 & p^3 \end{vmatrix} + 0 + 0$$

$$\text{and } f'''(x) = \begin{vmatrix} 6 & -\cos x & \sin x \\ 6 & -1 & 0 \\ p & p^2 & p^3 \end{vmatrix} + 0 + 0$$

$$\therefore f'''(0) = \begin{vmatrix} 6 & -1 & 0 \\ 6 & -1 & 0 \\ p & p^2 & p^3 \end{vmatrix} = 0 = \text{independent of } p$$

21. Since, $y^2 = P(x)$

On differentiating both sides, we get

$$2yy_1 = P'(x),$$

Again, differentiating, we get

$$2yy_2 + 2y_1^2 = P''(x)$$

$$\Rightarrow 2y^3 y_2 + 2y^2 y_1^2 = y^2 P''(x)$$

$$\Rightarrow 2y^3 y_2 = y^2 P''(x) - 2(yy_1)^2$$

$$\Rightarrow 2y^3 y_2 = P(x) \cdot P''(x) - \frac{\{P'(x)\}^2}{2}$$

Again, differentiating, we get

$$2 \frac{d}{dx} (y^3 y_2) = P'(x) \cdot P''(x) + P(x) \cdot P'''(x) - \frac{2P'(x) \cdot P''(x)}{2}$$

$$\Rightarrow 2 \frac{d}{dx} (y^3 y_2) = P(x) \cdot P'''(x)$$

$$\Rightarrow 2 \frac{d}{dx} \left(y^3 \cdot \frac{d^2 y}{dx^2} \right) = P(x) \cdot P'''(x)$$

22. Given, $xe^{xy} = y + \sin^2 x$... (i)

On putting $x=0$, we get

$$0 \cdot e^0 = y + 0$$

$$\Rightarrow y = 0$$

On differentiating Eq. (i) both sides w.r.t. x , we get

$$1 \cdot e^{xy} + x \cdot e^{xy} \left(x \cdot \frac{dy}{dx} + y \right) = \frac{dy}{dx} + 2 \sin x \cos x$$

On putting $x=0, y=0$, we get

$$e^0 + 0(0+0) = \left[\frac{dy}{dx} \right]_{(0,0)} + 2 \sin 0 \cos 0$$

$$\Rightarrow \left[\frac{dy}{dx} \right]_{0,0} = 1$$

23. Given, $f(x) = x|x|$

$$\Rightarrow f(x) = \begin{cases} x^2, & \text{if } x \geq 0 \\ -x^2, & \text{if } x < 0 \end{cases}$$

$f(x)$ is not differentiable at $x=0$ but all $R - \{0\}$.

$$\text{Therefore, } f'(x) = \begin{cases} 2x, & x > 0 \\ -2x, & x < 0 \end{cases}$$

$$\Rightarrow f''(x) = \begin{cases} 2, & x > 0 \\ -2, & x < 0 \end{cases}$$

Therefore, $f(x)$ is twice differentiable for all $x \in R - \{0\}$.

24. Given, $f(x) = |x-2|$

$$\therefore g(x) = f[f(x)] = ||x-2|-2|$$

When, $x > 2$

$$g(x) = |(x-2)-2| = |x-4| = x-4$$

$$\therefore g'(x) = 1 \text{ when } x > 2$$

25. Let $u = \sec^{-1} \left(-\frac{1}{2x^2-1} \right)$ and $v = \sqrt{1-x^2}$

Put $x = \cos \theta$

$$\therefore u = \sec^{-1}(-\sec 2\theta) \text{ and } v = \sin \theta$$

$$\Rightarrow u = \pi - 2\theta \quad [\because \sec^{-1}(-x) = \pi - \sec^{-1} x]$$

and $v = \sin \theta$

$$\Rightarrow \frac{du}{d\theta} = -2 \text{ and } \frac{dv}{d\theta} = \cos \theta$$

$$\Rightarrow \frac{du}{dv} = -\frac{2}{\cos \theta}, \left(\frac{du}{dv} \right)_{\theta=\pi/3} = -4$$

26. Given, $f(x) = \log_x(\log x)$

$$\therefore f(x) = \frac{\log(\log x)}{\log x}$$

On differentiating both sides, we get

$$f'(x) = \frac{(\log x) \left(\frac{1}{\log x} \cdot \frac{1}{x} \right) - \log(\log x) \cdot \frac{1}{x}}{(\log x)^2}$$

$$\therefore f'(e) = \frac{1 \cdot \left(\frac{1}{1} \cdot \frac{1}{e} \right) - \log(1) \cdot \frac{1}{e}}{(1)^2} \Rightarrow f'(e) = \frac{1}{e}$$

$$\begin{aligned}
 27. \text{ Given, } F(x) &= \begin{vmatrix} f_1(x) & f_2(x) & f_3(x) \\ g_1(x) & g_2(x) & g_3(x) \\ h_1(x) & h_2(x) & h_3(x) \end{vmatrix} \\
 \therefore F'(x) &= \begin{vmatrix} f_1'(x) & f_2'(x) & f_3'(x) \\ g_1(x) & g_2(x) & g_3(x) \\ h_1(x) & h_2(x) & h_3(x) \end{vmatrix} \\
 &+ \begin{vmatrix} f_1(x) & f_2(x) & f_3(x) \\ g_1'(x) & g_2'(x) & g_3'(x) \\ h_1(x) & h_2(x) & h_3(x) \end{vmatrix} + \begin{vmatrix} f_1(x) & f_2(x) & f_3(x) \\ g_1(x) & g_2(x) & g_3(x) \\ h_1'(x) & h_2'(x) & h_3'(x) \end{vmatrix} \\
 \Rightarrow F'(a) &= 0 + 0 + 0 = 0 \\
 &[\because f_r(a) = g_r(a) = h_r(a); r = 1, 2, 3]
 \end{aligned}$$

$$\begin{aligned}
 28. \text{ Given, } y &= f\left(\frac{2x-1}{x^2+1}\right) \\
 \text{and } f'(x) &= \sin^2 x \\
 \therefore \frac{dy}{dx} &= f'\left(\frac{2x-1}{x^2+1}\right) \cdot \frac{d}{dx}\left(\frac{2x-1}{x^2+1}\right) \\
 &= \sin^2\left(\frac{2x-1}{x^2+1}\right) \cdot \left\{ \frac{(x^2+1) \cdot 2 - (2x-1)(2x)}{(x^2+1)^2} \right\} \\
 &= \sin^2\left(\frac{2x-1}{x^2+1}\right) \cdot \frac{-2x^2+2x+2}{(x^2+1)^2} \\
 &= \frac{-2(x^2-x-1)}{(x^2+1)^2} \sin^2\left(\frac{2x-1}{x^2+1}\right)
 \end{aligned}$$

$$\begin{aligned}
 29. \quad y &= \frac{ax^2}{(x-a)(x-b)(x-c)} + \frac{bx}{(x-b)(x-c)} + \frac{c}{(x-c)} + 1 \\
 &= \frac{ax^2}{(x-a)(x-b)(x-c)} + \frac{bx}{(x-b)(x-c)} + \frac{x}{(x-c)} \\
 &= \frac{ax^2}{(x-a)(x-b)(x-c)} + \frac{x}{(x-c)} \left(\frac{b}{x-b} + 1 \right) \\
 &= \frac{ax^2}{(x-a)(x-b)(x-c)} + \frac{x}{(x-c)} \cdot \frac{x}{(x-b)} \\
 &= \frac{x^2}{(x-c)(x-b)} \left(\frac{a}{x-1} + 1 \right) \\
 \Rightarrow y &= \frac{x^3}{(x-a)(x-b)(x-c)} \\
 \Rightarrow \log y &= \log x^3 - \log(x-a)(x-b)(x-c) \\
 \Rightarrow \log y &= 3 \log x - \log(x-a) - \log(x-b) - \log(x-c) \\
 \text{On differentiating, we get} \\
 \frac{y'}{y} &= \frac{3}{x} - \frac{1}{x-a} - \frac{1}{x-b} - \frac{1}{x-c} \\
 \Rightarrow \frac{y'}{y} &= \left(\frac{1}{x} - \frac{1}{x-a} \right) + \left(\frac{1}{x} - \frac{1}{x-b} \right) + \left(\frac{1}{x} - \frac{1}{x-c} \right) \\
 \Rightarrow \frac{y'}{y} &= \frac{-a}{x(x-a)} - \frac{b}{x(x-b)} - \frac{c}{x(x-c)} \\
 \Rightarrow \frac{y'}{y} &= \frac{a}{x(a-x)} + \frac{b}{x(b-x)} + \frac{c}{x(c-x)} \\
 \Rightarrow \frac{y'}{y} &= \frac{1}{x} \left(\frac{a}{a-x} + \frac{b}{b-x} + \frac{c}{c-x} \right)
 \end{aligned}$$

$$30. \text{ Here, } (\sin y)^{\sin \frac{\pi}{2}x} + \frac{\sqrt{3}}{2} \sec^{-1}(2x) + 2^x \tan \{\log(x+2)\} = 0$$

On differentiating both sides, we get

$$\begin{aligned}
 (\sin y)^{\sin \frac{\pi}{2}x} \cdot \log(\sin y) \cdot \cos \frac{\pi}{2}x \cdot \frac{\pi}{2} \\
 + \left(\sin \frac{\pi}{2}x \right) (\sin y)^{\left(\sin \frac{\pi}{2}x \right) - 1} \cdot \cos y \cdot \frac{dy}{dx} \\
 + \frac{\sqrt{3}}{2} \cdot \frac{2}{(2|x|)\sqrt{4x^2-1}} + \frac{2^x \cdot \sec^2 \{\log(x+2)\}}{(x+2)} \\
 + 2^x \log 2 \cdot \tan \{\log(x+2)\} = 0
 \end{aligned}$$

Putting $\left(x = -1, y = -\frac{\sqrt{3}}{\pi} \right)$, we get

$$\frac{dy}{dx} = \frac{\left(-\frac{\sqrt{3}}{\pi} \right)^2}{\sqrt{1 - \left(\frac{\sqrt{3}}{\pi} \right)^2}} = \frac{3}{\pi \sqrt{\pi^2 - 3}}$$

$$31. \text{ Given, } x = \sec \theta - \cos \theta \text{ and } y = \sec^n \theta - \cos^n \theta$$

On differentiating w.r.t. θ respectively, we get

$$\frac{dx}{d\theta} = \sec \theta \tan \theta + \sin \theta$$

$$\text{and } \frac{dy}{d\theta} = n \sec^{n-1} \theta \cdot \sec \theta \tan \theta - n \cos^{n-1} \theta \cdot (-\sin \theta)$$

$$\Rightarrow \frac{dx}{d\theta} = \tan \theta (\sec \theta + \cos \theta)$$

$$\text{and } \frac{dy}{d\theta} = n \tan \theta (\sec^n \theta + \cos^n \theta)$$

$$\Rightarrow \frac{dy}{dx} = \frac{n (\sec^n \theta + \cos^n \theta)}{\sec \theta + \cos \theta}$$

$$\begin{aligned}
 \therefore \left(\frac{dy}{dx} \right)^2 &= \frac{n^2 (\sec^n \theta + \cos^n \theta)^2}{(\sec \theta + \cos \theta)^2} \\
 &= \frac{n^2 \{ (\sec^n \theta - \cos^n \theta)^2 + 4 \}}{\{ (\sec \theta - \cos \theta)^2 + 4 \}} = \frac{n^2 (y^2 + 4)}{(x^2 + 4)}
 \end{aligned}$$

$$\Rightarrow (x^2 + 4) \left(\frac{dy}{dx} \right)^2 = n^2 (y^2 + 4)$$

$$32. \text{ Let } \phi(x) = \begin{vmatrix} A(x) & B(x) & C(x) \\ A(\alpha) & B(\alpha) & C(\alpha) \\ A'(\alpha) & B'(\alpha) & C'(\alpha) \end{vmatrix} \quad \dots(i)$$

Given that, α is repeated root of quadratic equation $f(x) = 0$.

\therefore We must have $f(x) = (x - \alpha)^2 \cdot g(x)$

$$\therefore \phi'(x) = \begin{vmatrix} A'(x) & B'(x) & C'(x) \\ A(\alpha) & B(\alpha) & C(\alpha) \\ A'(\alpha) & B'(\alpha) & C'(\alpha) \end{vmatrix}$$

$$\Rightarrow \phi'(\alpha) = \begin{vmatrix} A'(\alpha) & B'(\alpha) & C'(\alpha) \\ A(\alpha) & B(\alpha) & C(\alpha) \\ A'(\alpha) & B'(\alpha) & C'(\alpha) \end{vmatrix} = 0$$

$\Rightarrow x = \alpha$ is root of $\phi'(x)$.

238 Limit, Continuity and Differentiability

$\Rightarrow (x - \alpha)$ is a factor of $\phi'(x)$ also.
or we can say $(x - \alpha)^2$ is a factor of $f(x)$.

$\Rightarrow \phi(x)$ is divisible by $f(x)$.

33. Given, $y = \left\{ (\log_{\cos x} \sin x) \cdot (\log_{\sin x} \cos x)^{-1} + \sin^{-1} \left(\frac{2x}{1+x^2} \right) \right\}$

$$\therefore y = \left(\frac{\log_e(\sin x)}{\log_e(\cos x)} \right)^2 + \sin^{-1} \left(\frac{2x}{1+x^2} \right)$$

$$\Rightarrow \frac{dy}{dx} = 2 \left\{ \frac{\log_e(\sin x)}{\log_e(\cos x)} \cdot \frac{\log_e(\cos x) \cdot \cot x + \log_e(\sin x) \cdot \tan x}{\{\log_e(\cos x)\}^2} \right\} + \frac{2}{1+x^2}$$

$$\Rightarrow \left(\frac{dy}{dx} \right)_{\left(x = \frac{\pi}{4} \right)} = 2 \left\{ 1 \cdot \frac{2 \cdot \log \left(\frac{1}{\sqrt{2}} \right)}{\left(\log \frac{1}{\sqrt{2}} \right)^2} \right\} + \frac{2}{1 + \frac{\pi^2}{16}}$$

$$= -\frac{8}{\log_e 2} + \frac{32}{16 + \pi^2}$$

34. Given, $(a + bx) e^{y/x} = x \Rightarrow y = x \log \left(\frac{x}{a + bx} \right)$

$$\Rightarrow y = x [\log(x) - \log(a + bx)] \quad \dots(i)$$

On differentiating both sides, we get

$$\frac{dy}{dx} = x \left(\frac{1}{x} - \frac{b}{a + bx} \right) + 1 [\log(x) - \log(a + bx)]$$

$$\Rightarrow x \frac{dy}{dx} = x^2 \left(\frac{a}{x(a + bx)} \right) + y \Rightarrow x y_1 = \frac{ax}{a + bx} + y \quad \dots(ii)$$

Again, differentiating both sides, we get

$$x y_2 + y_1 = a \left\{ \frac{(a + bx) \cdot 1 - x \cdot b}{(a + bx)^2} \right\} + y_1$$

$$\Rightarrow x^3 y_2 = \frac{a^2 x^2}{(a + bx)^2} \Rightarrow x^3 y_2 = \left(\frac{ax}{a + bx} \right)^2 \quad [\text{from Eq. (ii)}]$$

$$\Rightarrow x^3 y_2 = (x y_1 - y)^2 \Rightarrow x^3 \frac{d^2 y}{dx^2} = \left(x \frac{dy}{dx} - y \right)^2$$

35. Given, $h(x) = [f(x)]^2 + [g(x)]^2$

$$\Rightarrow h'(x) = 2f(x) \cdot f'(x) + 2g(x) \cdot g'(x)$$

$$= 2[f(x) \cdot g'(x) - g(x) \cdot f'(x)]$$

$$= 0 \quad [\because f'(x) = g'(x) \text{ and } g'(x) = -f'(x)]$$

$\therefore h(x)$ is constant.

$$\Rightarrow h(10) = h(5) = 11$$

36. Since, $y = e^{x \sin x^3} + (\tan x)^x$, then

$$y = u + v, \text{ where } u = e^{x \sin x^3} \text{ and } v = (\tan x)^x$$

$$\Rightarrow \frac{dy}{dx} = \left(\frac{du}{dx} + \frac{dv}{dx} \right) \quad \dots(i)$$

Here, $u = e^{x \sin x^3}$ and $\log v = x \log(\tan x)$

On differentiating both sides w.r.t. x , we get

$$\frac{du}{dx} = e^{x \sin x^3} \cdot (3x^3 \cos x^3 + \sin x^3) \quad \dots(ii)$$

and $\frac{1}{v} \frac{dv}{dx} = \frac{x \cdot \sec^2 x}{\tan x} + \log(\tan x)$

$$\frac{dv}{dx} = (\tan x)^x [2x \cdot \operatorname{cosec}(2x) + \log(\tan x)] \quad \dots(iii)$$

From Eqs. (i), (ii) and (iii), we get

$$\frac{dy}{dx} = e^{x \sin x^3} (3x^3 \cdot \cos x^3 + \sin x^3) + (\tan x)^x [2x \operatorname{cosec} 2x + \log(\tan x)]$$

37. Given, $y = \frac{5x}{3|1-x|} + \cos^2(2x+1)$

$$\Rightarrow y = \begin{cases} \frac{5x}{3(1-x)} + \cos^2(2x+1), & x < 1 \\ \frac{5x}{3(x-1)} + \cos^2(2x+1), & x > 1 \end{cases}$$

The function is not defined at $x = 1$.

$$\Rightarrow \frac{dy}{dx} = \begin{cases} \frac{5}{3} \left\{ \frac{(1-x) - x(-1)}{(1-x)^2} \right\} - 2 \sin(4x+2), & x < 1 \\ \frac{5}{3} \left\{ \frac{(x-1) - x(1)}{(x-1)^2} \right\} - 2 \sin(4x+2), & x > 1 \end{cases}$$

$$\Rightarrow \frac{dy}{dx} = \begin{cases} \frac{5}{3(1-x)^2} - 2 \sin(4x+2), & x < 1 \\ -\frac{5}{3(x-1)^2} - 2 \sin(4x+2), & x > 1 \end{cases}$$

38. Here, $\lim_{x \rightarrow 1} \frac{F(x)}{G(x)} = \frac{1}{14}$

$$\Rightarrow \lim_{x \rightarrow 1} \frac{F'(x)}{G'(x)} = \frac{1}{14} \quad [\text{using L'Hospital's rule}] \dots(i)$$

As $F(x) = \int_{-1}^x f(t) dt \Rightarrow F'(x) = f(x) \quad \dots(ii)$

and $G(x) = \int_{-1}^x t |f(t)| dt$

$$\Rightarrow G'(x) = x |f(x)| \quad \dots(iii)$$

$$\therefore \lim_{x \rightarrow 1} \frac{F(x)}{G(x)} = \lim_{x \rightarrow 1} \frac{F'(x)}{G'(x)} = \lim_{x \rightarrow 1} \frac{f(x)}{x |f(x)|}$$

$$= \frac{f(1)}{1 |f(1)|} = \frac{1/2}{|f(1/2)|} \quad \dots(iv)$$

Given, $\lim_{x \rightarrow 1} \frac{F(x)}{G(x)} = \frac{1}{14}$

$$\therefore \frac{\frac{1}{2}}{\left| f\left(\frac{1}{2}\right) \right|} = \frac{1}{14} \Rightarrow \left| f\left(\frac{1}{2}\right) \right| = 7$$

10

Application of Derivatives

Topic 1 Equations of Tangent and Normal

Objective Questions I (Only one correct option)

1. If the tangent to the curve $y = \frac{x}{x^2 - 3}$, $x \in R$, ($x \neq \pm \sqrt{3}$), at

a point $(\alpha, \beta) \neq (0, 0)$ on it is parallel to the line $2x + 6y - 11 = 0$, then **(2019 Main, 10 April II)**

- (a) $|6\alpha + 2\beta| = 19$ (b) $|6\alpha + 2\beta| = 9$
(c) $|2\alpha + 6\beta| = 19$ (d) $|2\alpha + 6\beta| = 11$
2. Let S be the set of all values of x for which the tangent to the curve $y = f(x) = x^3 - x^2 - 2x$ at (x, y) is parallel to the line segment joining the points $(1, f(1))$ and $(-1, f(-1))$, then S is equal to **(2019 Main, 9 April I)**
- (a) $\left\{\frac{1}{3}, -1\right\}$ (b) $\left\{\frac{1}{3}, 1\right\}$ (c) $\left\{-\frac{1}{3}, 1\right\}$ (d) $\left\{-\frac{1}{3}, -1\right\}$
3. If the tangent to the curve, $y = x^3 + ax - b$ at the point $(1, -5)$ is perpendicular to the line, $-x + y + 4 = 0$, then which one of the following points lies on the curve? **(2019 Main, 9 April I)**
- (a) $(-2, 2)$ (b) $(2, -2)$
(c) $(-2, 1)$ (d) $(2, -1)$
4. The tangent to the curve $y = x^2 - 5x + 5$, parallel to the line $2y = 4x + 1$, also passes through the point **(2019 Main, 12 Jan II)**
- (a) $\left(\frac{1}{4}, \frac{7}{2}\right)$ (b) $\left(\frac{7}{2}, \frac{1}{4}\right)$ (c) $\left(-\frac{1}{8}, 7\right)$ (d) $\left(\frac{1}{8}, -7\right)$
5. A helicopter is flying along the curve given by $y - x^{3/2} = 7$, ($x \geq 0$). A soldier positioned at the point $\left(\frac{1}{2}, 7\right)$ wants to shoot down the helicopter when it is nearest to him. Then, this nearest distance is **(2019 Main, 10 Jan II)**
- (a) $\frac{1}{3}\sqrt{7}$ (b) $\frac{\sqrt{5}}{6}$ (c) $\frac{1}{6}\sqrt{7}$ (d) $\frac{1}{2}$
6. If θ denotes the acute angle between the curves, $y = 10 - x^2$ and $y = 2 + x^2$ at a point of their intersection, then $|\tan \theta|$ is equal to **(2019 Main, 9 Jan I)**
- (a) $\frac{7}{17}$ (b) $\frac{8}{15}$ (c) $\frac{4}{9}$ (d) $\frac{8}{17}$
7. If the curves $y^2 = 6x$, $9x^2 + by^2 = 16$ intersect each other at right angles, then the value of b is **(2018 Main)**
- (a) 6 (b) $\frac{7}{2}$ (c) 4 (d) $\frac{9}{2}$

8. The normal to the curve $y(x-2)(x-3) = x+6$ at the point, where the curve intersects the Y -axis passes through the point **(2017 Main)**

(a) $\left(-\frac{1}{2}, -\frac{1}{2}\right)$ (b) $\left(\frac{1}{2}, \frac{1}{2}\right)$
(c) $\left(\frac{1}{2}, -\frac{1}{3}\right)$ (d) $\left(\frac{1}{2}, \frac{1}{3}\right)$

9. Consider $f(x) = \tan^{-1}\left(\sqrt{\frac{1+\sin x}{1-\sin x}}\right)$, $x \in \left(0, \frac{\pi}{2}\right)$.

A normal to $y = f(x)$ at $x = \frac{\pi}{6}$ also passes through the point **(2016 Main)**

(a) $(0, 0)$ (b) $\left(0, \frac{2\pi}{3}\right)$
(c) $\left(\frac{\pi}{6}, 0\right)$ (d) $\left(\frac{\pi}{4}, 0\right)$

10. The normal to the curve $x^2 + 2xy - 3y^2 = 0$ at $(1, 1)$
- (a) does not meet the curve again **(2015 Main)**
(b) meets in the curve again the second quadrant
(c) meets the curve again in the third quadrant
(d) meets the curve again in the fourth quadrant
11. The point(s) on the curve $y^3 + 3x^2 = 12y$, where the tangent is vertical, is (are) **(2002, 2M)**
- (a) $\left(\pm\frac{4}{\sqrt{3}}, -2\right)$ (b) $\left(\pm\sqrt{\frac{11}{3}}, 0\right)$ (c) $(0, 0)$
(d) $\left(\pm\frac{4}{\sqrt{3}}, 2\right)$
12. If the normal to the curve $y = f(x)$ at the point $(3, 4)$ makes an angle $\frac{3\pi}{4}$ with the positive X -axis, then $f'(3)$ is equal to **(2000, 1M)**
- (a) -1 (b) $-3/4$
(c) $4/3$ (d) 1
13. The normal to the curve $x = a(\cos \theta + \theta \sin \theta)$, $y = a(\sin \theta - \theta \cos \theta)$ at any point ' θ ' is such that
- (a) it makes a constant angle with the X -axis **(1983, 1M)**
(b) it passes through the origin
(c) it is at a constant distance from the origin
(d) None of the above

240 Application of Derivatives

Objective Questions II

(One or more than one correct option)

14. On the ellipse $4x^2 + 9y^2 = 1$, the point at which the tangents are parallel to the line $8x = 9y$, are (1999, 2M)
- (a) $\left(\frac{2}{5}, \frac{1}{5}\right)$
 (b) $\left(-\frac{2}{5}, \frac{1}{5}\right)$
 (c) $\left(-\frac{2}{5}, -\frac{1}{5}\right)$
 (d) $\left(\frac{2}{5}, -\frac{1}{5}\right)$
15. If the line $ax + by + c = 0$ is a normal to the curve $xy = 1$, then (1986, 2M)
- (a) $a > 0, b > 0$
 (b) $a > 0, b < 0$
 (c) $a < 0, b > 0$
 (d) $a < 0, b < 0$

Fill in the Blank

16. Let C be the curve $y^3 - 3xy + 2 = 0$. If H is the set of points on the curve C , where the tangent is horizontal and V is the set of points on the curve C , where the tangent is vertical, then $H = \dots$ and $V = \dots$. (1994, 2M)

Analytical & Descriptive Questions

17. If $|f(x_1) - f(x_2)| \leq (x_1 - x_2)^2, \forall x_1, x_2 \in R$. Find the equation of tangent to the curve $y = f(x)$ at the point $(1, 2)$. (2005, 4M)
18. The curve $y = ax^3 + bx^2 + cx + 5$, touches the X -axis at $P(-2, 0)$ and cuts the Y -axis at a point Q , where its gradient is 3. Find a, b, c . (1994, 5M)
19. Tangent at a point P_1 {other than $(0, 0)$ } on the curve $y = x^3$ meets the curve again at P_2 . The tangent at P_2 meets the curve at P_3 and so on. Show that the abscissa of $P_1, P_2, P_3, \dots, P_n$, form a GP. Also, find the ratio of $[\text{area}(\Delta P_1 P_2 P_3)]/[\text{area}(\Delta P_2 P_3 P_4)]$. (1993, 5M)
20. Find the equation of the normal to the curve $y = (1 + x)^y + \sin^{-1}(\sin^2 x)$ at $x = 0$. (1993, 4M)
21. Find all the tangents to the curve $y = \cos(x + y)$, $-2\pi \leq x \leq 2\pi$, that are parallel to the line $x + 2y = 0$. (1985, 5M)

Integer & Numerical Answer Type Question

22. The slope of the tangent to the curve $(y - x^5)^2 = x(1 + x^2)^2$ at the point $(1, 3)$ is (2014 Adv.)

Topic 2 Rate Measure, Increasing and Decreasing Functions

Objective Questions I (Only one correct option)

1. A spherical iron ball of radius 10 cm is coated with a layer of ice of uniform thickness that melts at a rate of $50 \text{ cm}^3/\text{min}$. When the thickness of the ice is 5 cm, then the rate at which the thickness (in cm/min) of the ice decreases, is (2020 Main, 9 Jan I)
- (a) $\frac{1}{9\pi}$ (b) $\frac{5}{6\pi}$
 (c) $\frac{1}{36\pi}$ (d) $\frac{1}{18\pi}$
2. Let $f(x) = e^x - x$ and $g(x) = x^2 - x, \forall x \in R$. Then, the set of all $x \in R$, where the function $h(x) = (f \circ g)(x)$ is increasing, is (2019 Main, 10 April II)
- (a) $\left[0, \frac{1}{2}\right] \cup [1, \infty)$ (b) $\left[-1, \frac{-1}{2}\right] \cup \left[\frac{1}{2}, \infty\right)$
 (c) $[0, \infty)$ (d) $\left[\frac{-1}{2}, 0\right] \cup [1, \infty)$
3. A water tank has the shape of an inverted right circular cone, whose semi-vertical angle is $\tan^{-1}\left(\frac{1}{2}\right)$. Water is poured into it at a constant rate of 5 cu m/min . Then, the rate (in m/min) at which the level of water is rising at the instant when the depth of water in the tank is 10 m is (2019 Main, 9 April II)
- (a) $\frac{2}{\pi}$ (b) $\frac{1}{5\pi}$ (c) $\frac{1}{15\pi}$ (d) $\frac{1}{10\pi}$

4. Let $f: [0, 2] \rightarrow R$ be a twice differentiable function such that $f''(x) > 0$, for all $x \in (0, 2)$. If $\phi(x) = f(x) + f(2 - x)$, then ϕ is (2019 Main, 8 April I)
- (a) increasing on $(0, 1)$ and decreasing on $(1, 2)$
 (b) decreasing on $(0, 2)$
 (c) decreasing on $(0, 1)$ and increasing on $(1, 2)$
 (d) increasing on $(0, 2)$
5. If the function f given by $f(x) = x^3 - 3(a - 2)x^2 + 3ax + 7$, for some $a \in R$ is increasing in $(0, 1]$ and decreasing in $[1, 5)$, then a root of the equation, $\frac{f(x) - 14}{(x - 1)^2} = 0 (x \neq 1)$ is (2019 Main, 12 Jan II)
- (a) -7 (b) 6 (c) 7 (d) 5
6. Let $f(x) = \frac{x}{\sqrt{a^2 + x^2}} - \frac{d - x}{\sqrt{b^2 + (d - x)^2}}, x \in R$, where a, b and d are non-zero real constants. Then, (2019 Main, 11 Jan II)
- (a) f is an increasing function of x
 (b) f' is not a continuous function of x
 (c) f is a decreasing function of x
 (d) f is neither increasing nor decreasing function of x
7. If the function $g: (-\infty, \infty) \rightarrow \left(-\frac{\pi}{2}, \frac{\pi}{2}\right)$ is given by $g(u) = 2 \tan^{-1}(e^u) - \frac{\pi}{2}$. Then, g is (2008, 3M)

- (a) even and is strictly increasing in $(0, \infty)$
 (b) odd and is strictly decreasing in $(-\infty, \infty)$
 (c) odd and is strictly increasing in $(-\infty, \infty)$
 (d) neither even nor odd but is strictly increasing in $(-\infty, \infty)$
- 8.** If $f(x) = x^3 + bx^2 + cx + d$ and $0 < b^2 < c$, then in $(-\infty, \infty)$
 (a) $f(x)$ is strictly increasing function **(2004, 2M)**
 (b) $f(x)$ has a local maxima
 (c) $f(x)$ is strictly decreasing function
 (d) $f(x)$ is bounded
- 9.** The length of a longest interval in which the function $3 \sin x - 4 \sin^3 x$ is increasing, is **(2002, 2M)**
 (a) $\frac{\pi}{3}$ (b) $\frac{\pi}{2}$ (c) $\frac{3\pi}{2}$ (d) π
- 10.** If $f(x) = xe^{x(1-x)}$, then $f(x)$ is **(2001, 2M)**
 (a) increasing in $[-1/2, 1]$ (b) decreasing in R
 (c) increasing in R (d) decreasing in $[-1/2, 1]$
- 11.** For all $x \in (0, 1)$ **(2000, 1M)**
 (a) $e^x < 1 + x$ (b) $\log_e(1 + x) < x$
 (c) $\sin x > x$ (d) $\log_e x > x$
- 12.** Let $f(x) = \int e^x(x-1)(x-2) dx$. Then, f decreases in the interval **(2000, 2M)**
 (a) $(-\infty, -2)$ (b) $(-2, -1)$ (c) $(1, 2)$ (d) $(2, \infty)$
- 13.** The function $f(x) = \sin^4 x + \cos^4 x$ increases, if **(1999, 2M)**
 (a) $0 < x < \frac{\pi}{8}$ (b) $\frac{\pi}{4} < x < \frac{3\pi}{8}$
 (c) $\frac{3\pi}{8} < x < \frac{5\pi}{8}$ (d) $\frac{5\pi}{8} < x < \frac{3\pi}{4}$
- 14.** If $f(x) = \frac{x}{\sin x}$ and $g(x) = \frac{x}{\tan x}$, where $0 < x \leq 1$, then in this interval **(1997, 2M)**
 (a) both $f(x)$ and $g(x)$ are increasing functions
 (b) both $f(x)$ and $g(x)$ are decreasing functions
 (c) $f(x)$ is an increasing function
 (d) $g(x)$ is an increasing function
- 15.** The function $f(x) = \frac{\log(\pi + x)}{\log(e + x)}$ is **(1995, 1M)**
 (a) increasing on $(0, \infty)$
 (b) decreasing on $(0, \infty)$
 (c) increasing on $(0, \pi/e)$, decreasing on $(\pi/e, \infty)$
 (d) decreasing on $(0, \pi/e)$, increasing on $(\pi/e, \infty)$
- 16.** Let f and g be increasing and decreasing functions respectively from $[0, \infty)$ to $[0, \infty)$ and $h(x) = f\{g(x)\}$. If $h(0) = 0$, then $h(x) - h(1)$ is **(1987, 2M)**
 (a) always negative (b) always positive
 (c) strictly increasing (d) None of these

Objective Questions II

(One or more than one correct option)

- 17.** If $f: R \rightarrow R$ is a differentiable function such that $f'(x) > 2f(x)$ for all $x \in R$, and $f(0) = 1$ then **(2017 Adv.)**
 (a) $f(x) > e^{2x}$ in $(0, \infty)$ (b) $f'(x) < e^{2x}$ in $(0, \infty)$
 (c) $f(x)$ is increasing in $(0, \infty)$ (d) $f(x)$ is decreasing in $(0, \infty)$

- 18.** If $f: (0, \infty) \rightarrow R$ be given by **(2014 Adv.)**

$$f(x) = \int_{1/x}^x e^{-\left(t+\frac{1}{t}\right)} \frac{dt}{t}.$$

Then,

- (a) $f(x)$ is monotonically increasing on $[1, \infty)$
 (b) $f(x)$ is monotonically decreasing on $[0, 1]$
 (c) $f(x) + f\left(\frac{1}{x}\right) = 0, \forall x \in (0, \infty)$
 (d) $f(2^x)$ is an odd function of x on R
- 19.** If $h(x) = f(x) - f(x)^2 + f(x)^3$ for every real number x . Then, **(1998, 2M)**
 (a) h is increasing, whenever f is increasing
 (b) h is increasing, whenever f is decreasing
 (c) h is decreasing, whenever f is decreasing
 (d) Nothing can be said in general

Fill in the Blanks

- 20.** The set of all x for which $\log(1+x) \leq x$ is equal to **(1987, 2M)**
- 21.** The function $y = 2x^2 - \log|x|$ is monotonically increasing for values of $x (\neq 0)$, satisfying the inequalities... and monotonically decreasing for values of x satisfying the inequalities... **(1983, 2M)**

Match the Columns

Directions (Q.Nos. 22-24) by appropriately matching the information given in the three columns of the following table.

Let $f(x) = x + \log_e x - x \log_e x, x \in (0, \infty)$

Column 1 contains information about zeros of $f(x), f'(x)$ and $f''(x)$.

Column 2 contains information about the limiting behaviour of $f(x), f'(x)$ and $f''(x)$ at infinity.

Column 3 contains information about increasing/decreasing nature of $f(x)$ and $f'(x)$.

Column-1	Column-2	Column-3
(I) $f(x) = 0$ for some $x \in (1, e^2)$	(i) $\lim_{x \rightarrow \infty} f(x) = 0$	(P) f is increasing in $(0, 1)$
(II) $f'(x) = 0$ for some $x \in (1, e)$	(ii) $\lim_{x \rightarrow \infty} f(x) = -\infty$	(Q) f is decreasing in (e, e^2)
(III) $f'(x) = 0$ for some $x \in (0, 1)$	(iii) $\lim_{x \rightarrow \infty} f'(x) = -\infty$	(R) f' is increasing in $(0, 1)$
(IV) $f''(x) = 0$ for some $x \in (1, e)$	(iv) $\lim_{x \rightarrow \infty} f''(x) = 0$	(S) f' is decreasing in (e, e^2)

- 22.** Which of the following options is the only INCORRECT combination? **(2017 Adv.)**
 (a) (I) (iii) (P) (b) (II) (iv) (Q)
 (c) (II) (iii) (P) (d) (III) (i) (R)
- 23.** Which of the following options is the only CORRECT combination?
 (a) (I) (ii) (R) (b) (III) (iv) (P)
 (c) (II) (iii) (S) (d) (IV) (i) (S)

242 Application of Derivatives

24. Which of the following options is the only CORRECT combination?

- (a) (III) (iii) (R) (b) (IV) (iv) (S)
(c) (II) (ii) (Q) (d) (I) (i) (P)

25. Match the conditions/expressions in Column I with statements in Column II.

Let the functions defined in Column I have domain $(-\pi/2, \pi/2)$.

Column I	Column II
A. $x + \sin x$	p. increasing
B. $\sec x$	q. decreasing
	r. neither increasing nor decreasing

Analytical & Descriptive Questions

26. Prove that $\sin x + 2x \geq \frac{3x(x+1)}{\pi}, \forall x \in \left[0, \frac{\pi}{2}\right]$

(Justify the inequality, if any used). (2004, 4M)

27. Using the relation $2(1 - \cos x) < x^2, x \neq 0$ or prove that $\sin(\tan x) \geq x, \forall x \in [0, \pi/4]$. (2003, 4M)

28. If $-1 \leq p \leq 1$, then show that the equation $4x^3 - 3x - p = 0$ has a unique root in the interval $[1/2, 1]$ and identify it. (2001, 5M)

29. Let $f(x) = \begin{cases} xe^{ax}, & x \leq 0 \\ x + ax^2 - x^3, & x > 0 \end{cases}$

where, a is a positive constant. Find the interval in which $f'(x)$ is increasing. (1996, 3M)

30. Show that $2\sin x + 2\tan x \geq 3x$, where $0 \leq x < \pi/2$. (1990, 4M)

31. Show that $1 + x \log(x + \sqrt{x^2 + 1}) \geq \sqrt{1 + x^2} \forall x \geq 0$. (1983, 2M)

32. Given $A = \left\{x: \frac{\pi}{6} \leq x \leq \frac{\pi}{3}\right\}$ and $f(x) = \cos x - x(1+x)$. Find $f(A)$. (1980, 2M)

Topic 3 Rolle's and Lagrange's Theorem

Objective Question I (Only one correct option)

1. If $f: R \rightarrow R$ is a twice differentiable function such that

$f''(x) > 0$ for all $x \in R$, and $f\left(\frac{1}{2}\right) = \frac{1}{2}, f(1) = 1$, then (2017 Adv.)

- (a) $f'(1) \leq 0$ (b) $f'(1) > 1$
(c) $0 < f'(1) \leq \frac{1}{2}$ (d) $\frac{1}{2} < f'(1) \leq 1$

Assertion and Reason

2. Let $f(x) = 2 + \cos x$, for all real x .

Statement I For each real t , there exists a point c in $[t, t + \pi]$, such that $f'(c) = 0$. Because

Statement II $f(t) = f(t + 2\pi)$ for each real t . (2007, 3M)

- (a) Statement I is correct, Statement II is also correct; Statement II is the correct explanation of Statement I
(b) Statement I is correct, Statement II is also correct; Statement II is not the correct explanation of Statement I
(c) Statement I is correct; Statement II is incorrect
(d) Statement I is incorrect; Statement II is correct

Analytical & Descriptive Question

3. If $f(x)$ and $g(x)$ are differentiable functions for $0 \leq x \leq 1$, such that

$$f(0) = 2, g(0) = 0$$

$$f(1) = 6, g(1) = 2$$

Then, show that there exists c satisfying $0 < c < 1$ and $f'(c) = 2g'(c)$. (1982, 2M)

Topic 4 Maxima and Minima

Objective Questions I (Only one correct option)

1. Consider the rectangles lying in the region

$$\left\{(x, y) \in R \times R : 0 \leq x \leq \frac{\pi}{2} \text{ and } 0 \leq y \leq 2\sin(2x)\right\}$$

and having one side on the X-axis. The area of the rectangle which has the maximum perimeter among all such rectangles, is (2020 Adv.)

- (a) $\frac{3\pi}{2}$ (b) π
(c) $\frac{\pi}{2\sqrt{3}}$ (d) $\frac{\pi\sqrt{3}}{2}$

2. Let $f(x) = 5 - |x - 2|$ and $g(x) = |x + 1|, x \in R$. If $f(x)$ attains maximum value at α and $g(x)$ attains minimum value of β , then $\lim_{x \rightarrow -\alpha\beta} \frac{(x-1)(x^2-5x+6)}{x^2-6x+8}$ is equal to

(2019 Main, 12 April II)

- (a) $1/2$ (b) $-3/2$ (c) $-1/2$ (d) $3/2$

3. If the volume of parallelepiped formed by the vectors $\hat{i} + \lambda\hat{j} + \hat{k}, \hat{j} + \lambda\hat{k}$ and $\lambda\hat{i} + \hat{k}$ is minimum, then λ is equal to (2019 Main, 12 April I)

- (a) $-\frac{1}{\sqrt{3}}$ (b) $\frac{1}{\sqrt{3}}$ (c) $\sqrt{3}$ (d) $-\sqrt{3}$

4. If m is the minimum value of k for which the function $f(x) = x\sqrt{kx - x^2}$ is increasing in the interval $[0, 3]$ and M is the maximum value of f in the interval $[0, 3]$ when $k = m$, then the ordered pair (m, M) is equal to
(2019 Main, 12 April I)
- (a) $(4, 3\sqrt{2})$ (b) $(4, 3\sqrt{3})$
(c) $(3, 3\sqrt{3})$ (d) $(5, 3\sqrt{6})$
5. If $f(x)$ is a non-zero polynomial of degree four, having local extreme points at $x = -1, 0, 1$, then the set $S = \{x \in R : f(x) = f(0)\}$ contains exactly
(2019 Main, 9 April I)
- (a) four rational numbers
(b) two irrational and two rational numbers
(c) four irrational numbers
(d) two irrational and one rational number
6. The height of a right circular cylinder of maximum volume inscribed in a sphere of radius 3 is
(2019 Main, 8 April II)
- (a) $\sqrt{6}$ (b) $2\sqrt{3}$ (c) $\sqrt{3}$ (d) $\frac{2}{3}\sqrt{3}$
7. If S_1 and S_2 are respectively the sets of local minimum and local maximum points of the function, $f(x) = 9x^4 + 12x^3 - 36x^2 + 25$, $x \in R$, then
(2019 Main, 8 April I)
- (a) $S_1 = \{-2\}; S_2 = \{0, 1\}$
(b) $S_1 = \{-2, 0\}; S_2 = \{1\}$
(c) $S_1 = \{-2, 1\}; S_2 = \{0\}$
(d) $S_1 = \{-1\}; S_2 = \{0, 2\}$
8. The shortest distance between the line $y = x$ and the curve $y^2 = x - 2$ is
(2019 Main, 8 April I)
- (a) 2 (b) $\frac{7}{8}$ (c) $\frac{7}{4\sqrt{2}}$ (d) $\frac{11}{4\sqrt{2}}$
9. The maximum area (in sq. units) of a rectangle having its base on the X -axis and its other two vertices on the parabola, $y = 12 - x^2$ such that the rectangle lies inside the parabola, is
(2019 Main, 12 Jan I)
- (a) 36 (b) $20\sqrt{2}$ (c) 32 (d) $18\sqrt{3}$
10. The maximum value of the function $f(x) = 3x^3 - 18x^2 + 27x - 40$ on the set $S = \{x \in R : x^2 + 30 \leq 11x\}$ is
(2019 Main, 11 Jan I)
- (a) 122 (b) -122 (c) -222 (d) 222
11. Let $A(4, -4)$ and $B(9, 6)$ be points on the parabola, $y^2 = 4x$. Let C be chosen on the arc AOB of the parabola, where O is the origin, such that the area of $\triangle ACB$ is maximum. Then, the area (in sq. units) of $\triangle ACB$, is
(2019 Main, 9 Jan II)
- (a) $31\frac{1}{4}$ (b) 32 (c) $31\frac{3}{4}$ (d) $30\frac{1}{2}$
12. The maximum volume (in cu.m) of the right circular cone having slant height 3m is
(2019 Main, 9 Jan I)
- (a) $\frac{4}{3}\pi$ (b) $2\sqrt{3}\pi$ (c) $3\sqrt{3}\pi$ (d) 6π
13. Let $f(x) = x^2 + \frac{1}{x^2}$ and $g(x) = x - \frac{1}{x}$, $x \in R - \{-1, 0, 1\}$. If $h(x) = \frac{f(x)}{g(x)}$, then the local minimum value of $h(x)$ is
(2018 Main)
- (a) 3 (b) -3 (c) $-2\sqrt{2}$ (d) $2\sqrt{2}$
14. If 20 m of wire is available for fencing off a flower-bed in the form of a circular sector, then the maximum area (in sq. m) of the flower-bed is
(2017 Main)
- (a) 12.5 (b) 10
(c) 25 (d) 30
15. A wire of length 2 units is cut into two parts which are bent respectively to form a square of side = x units and a circle of radius = r units. If the sum of the areas of the square and the circle so formed is minimum, then
(2016 Main)
- (a) $2x = (\pi + 4)r$ (b) $(4 - \pi)x = \pi r$
(c) $x = 2r$ (d) $2x = r$
16. The least value of $\alpha \in R$ for which $4\alpha x^2 + \frac{1}{x} \geq 1$, for all $x > 0$, is
(2016 Adv.)
- (a) $\frac{1}{64}$ (b) $\frac{1}{32}$ (c) $\frac{1}{27}$ (d) $\frac{1}{25}$
17. Let $f(x)$ be a polynomial of degree four having extreme values at $x = 1$ and $x = 2$. If $\lim_{x \rightarrow 0} \left[1 + \frac{f(x)}{x^2} \right] = 3$, then $f(2)$ is equal to
- (a) -8 (b) -4
(c) 0 (d) 4
18. If $x = -1$ and $x = 2$ are extreme points of $f(x) = \alpha \log|x| + \beta x^2 + x$, then
(2014 Main)
- (a) $\alpha = -6, \beta = \frac{1}{2}$ (b) $\alpha = -6, \beta = -\frac{1}{2}$
(c) $\alpha = 2, \beta = -\frac{1}{2}$ (d) $\alpha = 2, \beta = \frac{1}{2}$
19. The number of points in $(-\infty, \infty)$ for which $x^2 - x \sin x - \cos x = 0$, is
(2013 Adv.)
- (a) 6 (b) 4 (c) 2 (d) 0
20. Let f, g and h be real-valued functions defined on the interval $[0, 1]$ by $f(x) = e^{x^2} + e^{-x^2}$, $g(x) = x e^{x^2} + e^{-x^2}$ and $h(x) = x^2 e^{x^2} + e^{-x^2}$. If a, b and c denote respectively, the absolute maximum of f, g and h on $[0, 1]$, then
(2010)
- (a) $a = b$ and $c \neq b$ (b) $a = c$ and $a \neq b$
(c) $a \neq b$ and $c \neq b$ (d) $a = b = c$
21. The total number of local maxima and local minima of the function $f(x) = \begin{cases} (2+x)^3, & -3 < x \leq -1 \\ x^{\frac{2}{3}}, & -1 < x < 2 \end{cases}$ is
(2008, 3M)
- (a) 0 (b) 1
(c) 2 (d) 3
22. If $f(x) = x^2 + 2bx + 2c^2$ and $g(x) = -x^2 - 2cx + b^2$, such that $\min f(x) > \max g(x)$, then the relation between b and c , is
(2003, 2M)
- (a) No real value of b and c (b) $0 < c < b\sqrt{2}$
(c) $|c| < |b|\sqrt{2}$ (d) $|c| > |b|\sqrt{2}$
23. If $f(x) = \begin{cases} |x|, & \text{for } 0 < |x| \leq 2 \\ 1, & \text{for } x = 0 \end{cases}$. Then, at $x = 0$, f has
(2000, 1M)
- (a) a local maximum (b) no local maximum
(c) a local minimum (d) no extremum

244 Application of Derivatives

24. If $f(x) = \frac{x^2 - 1}{x^2 + 1}$, for every real number x , then the minimum value of f (1998, 2M)
- (a) does not exist because f is unbounded
 (b) is not attained even though f is bounded
 (c) is 1 (d) is -1
25. The number of values of x , where the function $f(x) = \cos x + \cos(\sqrt{2}x)$ attains its maximum, is (1998, 2M)
- (a) 0 (b) 1 (c) 2 (d) infinite
26. On the interval $[0, 1]$, the function $x^{25}(1-x)^{75}$ takes its maximum value at the point (1995, 1M)
- (a) 0 (b) 1/4 (c) 1/2 (d) 1/3
27. Find the coordinates of all the points P on the ellipse $\frac{x^2}{a^2} + \frac{y^2}{b^2} = 1$, for which the area of the ΔPON is maximum, where O denotes the origin and N is the foot of the perpendicular from O to the tangent at P . (1990, 10M)
- (a) $\left(\frac{\pm a^2}{\sqrt{a^2 + b^2}}, \frac{\pm b^2}{\sqrt{a^2 + b^2}}\right)$ (b) $\left(\frac{\pm a^2}{\sqrt{a^2 - b^2}}, \frac{\pm b^2}{\sqrt{a^2 - b^2}}\right)$
 (c) $\left(\frac{\pm a^2}{\sqrt{a^2 + b^2}}, \frac{\pm b^2}{\sqrt{a^2 - b^2}}\right)$ (d) $\left(\frac{\pm a^2}{\sqrt{a^2 - b^2}}, \frac{\pm b^2}{\sqrt{a^2 + b^2}}\right)$
28. If $P(x) = a_0 + a_1x^2 + a_2x^4 + \dots + a_nx^{2n}$ is a polynomial in a real variable x with $0 < a_0 < a_1 < a_2 < \dots < a_n$. Then, the function $P(x)$ has (1986, 2M)
- (a) neither a maximum nor a minimum
 (b) only one maximum
 (c) only one minimum
 (d) only one maximum and only one minimum
29. If $y = a \log x + bx^2 + x$ has its extremum values at $x = -1$ and $x = 2$, then (1983, 1M)
- (a) $a = 2, b = -1$ (b) $a = 2, b = -\frac{1}{2}$
 (c) $a = -2, b = \frac{1}{2}$ (d) None of the above
30. If p, q and r are any real numbers, then (1982, 1M)
- (a) $\max(p, q) < \max(p, q, r)$
 (b) $\min(p, q) = \frac{1}{2}(p + q - |p - q|)$
 (c) $\max(p, q) < \min(p, q, r)$
 (d) None of the above

Objective Questions II

(One or more than one correct option)

31. Let $f: R \rightarrow R$ be given by $f(x) = (x-1)(x-2)(x-5)$. Define $F(x) = \int_0^x f(t)dt, x > 0$. Then which of the following options is/are correct? (2019 Adv.)
- (a) $F(x) \neq 0$ for all $x \in (0, 5)$
 (b) F has a local maximum at $x = 2$
 (c) F has two local maxima and one local minimum in $(0, \infty)$
 (d) F has a local minimum at $x = 1$

32. Let $f: R \rightarrow R$ be given by

$$f(x) = \begin{cases} x^5 + 5x^4 + 10x^3 + 10x^2 + 3x + 1, & x < 0; \\ x^2 - x + 1, & 0 \leq x < 1; \\ \frac{2}{3}x^3 - 4x^2 + 7x - \frac{8}{3}, & 1 \leq x < 3; \\ (x-2)\log_e(x-2) - x + \frac{10}{3}, & x \geq 3; \end{cases}$$

Then which of the following options is/are correct?

- (a) f is increasing on $(-\infty, 0)$ (2019 Adv.)
 (b) f' is NOT differentiable at $x = 1$
 (c) f is onto
 (d) f' has a local maximum at $x = 1$
33. If $f(x) = \begin{vmatrix} \cos(2x) & \cos(2x) & \sin(2x) \\ -\cos x & \cos x & -\sin x \\ \sin x & \sin x & \cos x \end{vmatrix}$, then (2017 Adv.)
- (a) $f(x)$ attains its minimum at $x = 0$
 (b) $f(x)$ attains its maximum at $x = 0$
 (c) $f'(x) = 0$ at more than three points in $(-\pi, \pi)$
 (d) $f'(x) = 0$ at exactly three points in $(-\pi, \pi)$
34. Let $f: R \rightarrow (0, \infty)$ and $g: R \rightarrow R$ be twice differentiable functions such that f'' and g' are continuous functions on R . Suppose $f'(2) = g(2) = 0, f''(2) \neq 0$ and $g'(2) \neq 0$. If $\lim_{x \rightarrow 2} \frac{f(x)g(x)}{f'(x)g'(x)} = 1$, then (2016 Adv.)

- (a) f has a local minimum at $x = 2$
 (b) f has a local maximum at $x = 2$
 (c) $f''(2) > f(2)$
 (d) $f(x) - f''(x) = 0$, for at least one $x \in R$

35. The function $f(x) = 2|x| + |x+2| - ||x+2| - 2|x||$ has a local minimum or a local maximum at x is equal to (2013 Adv.)
- (a) -2 (b) $-\frac{2}{3}$ (c) 2 (d) 2/3
36. A rectangular sheet of fixed perimeter with sides having their lengths in the ratio 8 : 15 is converted into an open rectangular box by folding after removing squares of equal area from all four corners. If the total area of removed squares is 100, the resulting box has maximum volume. The lengths of the sides of the rectangular sheet are (2013 Adv.)
- (a) 24 (b) 32 (c) 45 (d) 60

37. If $f(x) = \begin{cases} e^x, & 0 \leq x \leq 1 \\ 2 - e^{x-1}, & 1 < x \leq 2 \\ x - e, & 2 < x \leq 3 \end{cases}$ and $g(x) = \int_0^x f(t) dt$, $x \in [1, 3]$, then (2006, 3M)
- (a) $g(x)$ has local maxima at $x = 1 + \log_e 2$ and local minima at $x = e$
 (b) $f(x)$ has local maxima at $x = 1$ and local minima at $x = 2$
 (c) $g(x)$ has no local minima
 (d) $f(x)$ has no local maxima
38. If $f(x)$ is a cubic polynomial which has local maximum at $x = -1$. If $f(2) = 18, f(1) = -1$ and $f'(x)$ has local minimum at $x = 0$, then (2006, 3M)

- (a) the distance between $(-1, 2)$ and $(a, f(a))$, where $x = a$ is the point of local minima, is $2\sqrt{5}$
- (b) $f(x)$ is increasing for $x \in [1, 2\sqrt{5}]$
- (c) $f(x)$ has local minima at $x = 1$
- (d) the value of $f(0) = 5$

39. The function

$f(x) = \int_{-1}^x t(e^t - 1)(t - 1)(t - 2)^3(t - 3)^5 dt$ has a local minimum at x equals (1999, 3M)

- (a) 0
- (b) 1
- (c) 2
- (d) 3

40. If $f(x) = \begin{cases} 3x^2 + 12x - 1, & -1 \leq x \leq 2 \\ 37 - x, & 2 < x \leq 3 \end{cases}$ then (1993, 3M)

- (a) $f(x)$ is increasing on $[-1, 2]$
- (b) $f(x)$ is continuous on $[-1, 3]$
- (c) $f'(2)$ does not exist
- (d) $f(x)$ has the maximum value at $x = 2$

Match the Columns

41. A line $L : y = mx + 3$ meets Y -axis at $E(0, 3)$ and the arc of the parabola $y^2 = 16x, 0 \leq y \leq 6$ at the point $F(x_0, y_0)$. The tangent to the parabola at $F(x_0, y_0)$ intersects the Y -axis at $G(0, y_1)$. The slope m of the line L is chosen such that the area of the ΔEFG has a local maximum

Match List I with List II and select the correct answer using the codes given below the list.

	Column I	Column II
P.	$m =$	1. 1/2
Q.	Maximum area of ΔEFG is	2. 4
R.	$y_0 =$	3. 2
S.	$y_1 =$	4. 1

Codes

	P	Q	R	S		P	Q	R	S
(a)	4	1	2	3	(b)	3	4	1	2
(c)	1	3	2	4	(d)	1	3	4	2

Passage Based Problems

Consider the function $f : (-\infty, \infty) \rightarrow (-\infty, \infty)$ defined by $f(x) = \frac{x^2 - ax + 1}{x^2 + ax + 1}; 0 < a < 2$. (2008, 12M)

42. Which of the following is true ?

- (a) $(2 + a)^2 f''(1) + (2 - a)^2 f''(-1) = 0$
- (b) $(2 - a)^2 f''(1) - (2 + a)^2 f''(-1) = 0$
- (c) $f'(1) f'(-1) = (2 - a)^2$
- (d) $f'(1) f'(-1) = -(2 + a)^2$

43. Which of the following is true ?

- (a) $f(x)$ is decreasing on $(-1, 1)$ and has a local minimum at $x = 1$
- (b) $f(x)$ is increasing on $(-1, 1)$ and has a local maximum at $x = 1$
- (c) $f(x)$ is increasing on $(-1, 1)$ but has neither a local maximum nor a local minimum at $x = 1$
- (d) $f(x)$ is decreasing on $(-1, 1)$ but has neither a local maximum nor a local minimum at $x = 1$

44. Let $g(x) = \int_0^{e^x} \frac{f'(t)}{1+t^2} dt$. Which of the following is true?

- (a) $g'(x)$ is positive on $(-\infty, 0)$ and negative on $(0, \infty)$
- (b) $g'(x)$ is negative on $(-\infty, 0)$ and positive on $(0, \infty)$
- (c) $g'(x)$ changes sign on both $(-\infty, 0)$ and $(0, \infty)$
- (d) $g'(x)$ does not change sign $(-\infty, \infty)$

Analytical & Descriptive Questions

45. If $f(x)$ is twice differentiable function such that $f(a) = 0, f(b) = 2, f(c) = 1, f(d) = 2, f(e) = 0$, where $a < b < c < d < e$, then the minimum number of zeroes of $g(x) = \{f'(x)\}^2 + f''(x) \cdot f(x)$ in the interval $[a, e]$ is

46. For the circle $x^2 + y^2 = r^2$, find the value of r for which the area enclosed by the tangents drawn from the point $P(6, 8)$ to the circle and the chord of contact is maximum. (2003, 2M)

47. Find a point on the curve $x^2 + 2y^2 = 6$ whose distance from the line $x + y = 7$, is minimum. (2003, 2M)

48. Let $f(x)$ is a function satisfying the following conditions

- (i) $f(0) = 2, f(1) = 1$
- (ii) $f(x)$ has a minimum value at $x = 5/2$ and
- (iii) For all $x, f'(x) = \begin{vmatrix} 2ax & 2ax - 1 & 2ax + b + 1 \\ b & b + 1 & -1 \\ 2(ax + b) & 2ax + 2b + 1 & 2ax + b \end{vmatrix}$

where, a and b are some constants. Determine the constants a, b and the function $f(x)$. (1998, 8M)

49. Let C_1 and C_2 be respectively, the parabolas $x^2 = y - 1$ and $y^2 = x - 1$. Let P be any point on C_1 and Q be any point on C_2 . If P_1 and Q_1 is the reflections of P and Q , respectively, with respect to the line $y = x$. Prove that P_1 lies on C_2, Q_1 lies on C_1 and $PQ \geq \min(P P_1, Q Q_1)$. Hence, determine points P_0 and Q_0 on the parabolas C_1 and C_2 respectively such that $P_0 Q_0 \leq PQ$ for all pairs of points (P, Q) with P on C_1 and Q on C_2 .

50. If S is a square of unit area. Consider any quadrilateral which has one vertex on each side of S . If a, b, c and d denote the length of the sides of the quadrilateral, then prove that $2 \leq a^2 + b^2 + d^2 \leq 4$. (1997, 5M)

51. Determine the points of maxima and minima of the function $f(x) = \frac{1}{8} \ln x - bx + x^2, x > 0$, where $b \geq 0$ is a constant. (1996, 5M)

52. Let (h, k) be a fixed point, where $h > 0, k > 0$. A straight line passing through this point cuts the positive directions of the coordinate axes at the points P and Q . Find the minimum area of the $\Delta OPQ, O$ being the origin. (1995, 5M)

53. The circle $x^2 + y^2 = 1$ cuts the X -axis at P and Q . Another circle with centre at Q and variable radius intersects the first circle at R above the X -axis and the line segment PQ at S . Find the maximum area of the ΔQSR . (1994, 5M)

246 Application of Derivatives

54. Let $f(x) = \begin{cases} -x^3 + \frac{(b^3 - b^2 + b - 1)}{(b^2 + 3b + 2)}, & 0 \leq x \leq 1 \\ \frac{2x - 3}{2x - 3}, & 1 \leq x \leq 3 \end{cases}$

Find all possible real values of b such that $f(x)$ has the smallest value at $x = 1$. (1993, 5M)

55. What normal to the curve $y = x^2$ forms the shortest chord? (1992, 6M)

56. A window of perimeter (including the base of the arch) is in the form of a rectangle surmounted by a semi-circle. The semi-circular portion is fitted with coloured glass while the rectangular part is fitted with clear glass. The clear glass transmits three times as much light per square meter as the coloured glass does. What is the ratio for the sides of the rectangle so that the window transmits the maximum light? (1991, 4M)

57. A point P is given on the circumference of a circle of radius r . Chord QR is parallel to the tangent at P . Determine the maximum possible area of the ΔPQR . (1990, 4M)

58. Find the point on the curve $4x^2 + a^2y^2 = 4a^2$, $4 < a^2 < 8$ that is farthest from the point $(0, -2)$. (1987, 4M)

59. Let $A(p^2, -p)$, $B(q^2, q)$, $C(r^2, -r)$ be the vertices of the triangle ABC . A parallelogram $AFDE$ is drawn with vertices D, E and F on the line segments BC, CA and AB , respectively. Using calculus, show that maximum area of such a parallelogram is $\frac{1}{4}(p+q)(q+r)(p-r)$. (1986, 5M)

60. Let $f(x) = \sin^3 x + \lambda \sin^2 x$, $-\frac{\pi}{2} < x < \frac{\pi}{2}$. Find the intervals in which λ should lie in the order that $f(x)$ has exactly one minimum and exactly one maximum. (1985, 5M)

61. Find the coordinates of the point on the curve $y = \frac{x}{1+x^2}$, where the tangent to the curve has the greatest slope. (1984, 4M)

62. A swimmer S is in the sea at a distance d km from the closest point A on a straight shore. The house of the swimmer is on the shore at a distance L km from A . He can swim at a speed of u km/h and walk at a speed of v km/h ($v > u$). At what point on the shore should he land so that he reaches his house in the shortest possible time? (1983, 2M)

63. If $ax^2 + b/x \geq c$ for all positive x where $a > 0$ and $b > 0$, then show that $27ab^2 \geq 4c^3$. (1982, 2M)

64. If x and y be two real variables such that $x > 0$ and $xy = 1$. Then, find the minimum value of $x + y$. (1981, 2M)

Integer & Numerical Answer Type Questions

65. Let the function $f: (0, \pi) \rightarrow R$ be defined by $f(\theta) = (\sin \theta + \cos \theta)^2 + (\sin \theta - \cos \theta)^4$. Suppose the function f has a local minimum at θ precisely when $\theta \in \{\lambda_1\pi, \dots, \lambda_r\pi\}$, where $0 < \lambda_1 < \dots < \lambda_r < 1$. Then the value of $\lambda_1 + \dots + \lambda_r$ is (2020 Adv.)

66. For a polynomial $g(x)$ with real coefficients, let m_g denote the number of distinct real roots of $g(x)$. Suppose S is the set of polynomials with real coefficients defined by

$$S = \{(x^2 - 1)^2(a_0 + a_1x + a_2x^2 + a_3x^3) : a_0, a_1, a_2, a_3 \in \mathbf{R}\};$$

For a polynomial f , let f' and f'' denote its first and second order derivatives, respectively. Then the minimum possible value of $(m_{f'} + m_{f''})$, where $f \in S$, is (2020 Adv.)

67. Let AD and BC be two vertical poles at A and B respectively on a horizontal ground. If $AD = 8$ m, $BC = 11$ m and $AB = 10$ m; then the distance (in meters) of a point M on AB from the point A such that $MD^2 + MC^2$ is minimum is (2020 Main, 6 Sep I)

68. A cylindrical container is to be made from certain solid material with the following constraints : It has a fixed inner volume of V mm³, has a 2 mm thick solid wall and is open at the top. The bottom of the container is a solid circular disc of thickness 2 mm and is of radius equal to the outer radius of the container.

If the volume of the material used to make the container is minimum, when the inner radius of the container is 10 mm, then the value of $\frac{V}{250\pi}$ is (2015 Adv.)

69. A vertical line passing through the point $(h, 0)$ intersects the ellipse $\frac{x^2}{4} + \frac{y^2}{3} = 1$ at the points P and Q . If the tangents to the ellipse at P and Q meet at the point R .

If $\Delta(h) = \text{area of the } \Delta PQR$, $\Delta_1 = \max_{1/2 \leq h \leq 1} \Delta(h)$ and $\Delta_2 = \min_{1/2 \leq h \leq 1} \Delta(h)$, then $\frac{8}{\sqrt{5}} \Delta_1 - 8\Delta_2$ is equal to (2013 Adv.)

70. Let $f: R \rightarrow R$ be defined as $f(x) = |x| + |x^2 - 1|$. The total number of points at which f attains either a local maximum or a local minimum is (2012)

71. Let $p(x)$ be a real polynomial of least degree which has a local maximum at $x = 1$ and a local minimum at $x = 3$. If $p(1) = 6$ and $p(3) = 2$, then $p'(0)$ is equal to (2012)

72. The number of distinct real roots of $x^4 - 4x^3 + 12x^2 + x - 1 = 0$ is.....

73. Let f be a function defined on R (the set of all real numbers) such that $f'(x) = 2010(x - 2009)(x - 2010)^2(x - 2011)^3(x - 2012)^4$, $\forall x \in R$. If g is a function defined on R with values in the interval $(0, \infty)$ such that $f(x) = \ln(g(x))$, $\forall x \in R$, then the number of points in R at which g has a local maximum is..... (2010)

74. The maximum value of the expression $\frac{1}{\sin^2 \theta + 3 \sin \theta \cos \theta + 5 \cos^2 \theta}$ is (2010)

75. The maximum value of the function $f(x) = 2x^3 - 15x^2 + 36x - 48$ on the set $A = \{x \mid x^2 + 20 \leq 9x\}$ is (2009)

Answers

Topic 1

1. (a) 2. (c) 3. (b) 4. (d)
 5. (c) 6. (b) 7. (d) 8. (b)
 9. (b) 10. (d) 11. (d) 12. (d)
 13. (c) 14. (b, d) 15. (b, c)
 16. $H = \phi, V = \{1, 1\}$ 17. $y - 2 = 0$
 18. $a = -\frac{1}{2}, b = -\frac{3}{4}, c = 3$ 19. 1 : 16
 20. $y + x - 1 = 0$
 21. $x + 2y = \frac{\pi}{2}$ and $x + 2y = \frac{-3\pi}{2}$
 22. (8)

Topic 2

1. (d) 2. (a) 3. (b) 4. (c)
 5. (c) 6. (a) 7. (c) 8. (a)
 9. (a) 10. (a) 11. (b) 12. (c)
 13. (b) 14. (c) 15. (b) 16. (d)
 17. (a, c) 18. (c, d) 19. (a, c) 20. $x > -1$
 21. $x \in \left(-\frac{1}{2}, 0\right) \cup \left(\frac{1}{2}, \infty\right), x \in \left(-\infty, -\frac{1}{2}\right) \cup \left(0, \frac{1}{2}\right)$
 22. (d) 23. (c) 24. (c)
 25. $A \rightarrow p, B \rightarrow r$ 29. $\left[-\frac{2}{a}, \frac{a}{3}\right]$
 32. $\left[\frac{1}{2} - \frac{\pi}{3}\left(1 + \frac{\pi}{3}\right), \frac{\sqrt{3}}{2} - \frac{\pi}{6}\left(1 + \frac{\pi}{6}\right)\right]$

Topic 3

1. (b) 2. (b)

Topic 4

1. (c) 2. (a) 3. (b) 4. (b)
 5. (d) 6. (b) 7. (c) 8. (c)

9. (c) 10. (a) 11. (a) 12. (b)
 13. (d) 14. (c) 15. (c) 16. (c)
 17. (c) 18. (c) 19. (c) 20. (d)
 21. (c) 22. (d) 23. (a) 24. (d)
 25. (b) 26. (b) 27. (a)
 28. (c) 29. (b) 30. (b) 31. (a,b,d)
 32. (b,c,d) 33. (b, c) 34. (a, d) 35. (a, b)
 36. (a, c) 37. (a, b) 38. (b, c) 39. (b, d)
 40. (a, b, c, d) 41. (a) $P \rightarrow 4$ $Q \rightarrow 1$ $R \rightarrow 2$ $S \rightarrow 3$
 42. (a) 43. (a) 44. (a) 45. 6
 46. 5 units 47. (2, 1)
 48. $a = \frac{1}{4}, b = \frac{-5}{4}; f(x) = \frac{1}{4}x^2 - \frac{5}{4}x + 2$
 49. $P_0 = \left(\frac{1}{2}, \frac{5}{4}\right)$ and $Q_0 = \left(\frac{5}{4}, \frac{1}{2}\right)$
 51. Maxima at $x = \frac{(b - \sqrt{b^2 - 1})}{4}$ and minima at $x = \frac{1}{4}(b + \sqrt{b^2 - 1})$
 52. $2hk$ 53. $\frac{4\sqrt{3}}{9}$
 54. $b \in (-2, -1) \cup [1, \infty]$
 55. $\sqrt{2}x - 2y + 2 = 0, \sqrt{2}x + 2y - 2 = 0$
 56. $6 : 6 + \pi$ 57. $\frac{3\sqrt{3}}{4}r^2$ sq units 58. (0, 2)
 60. $\lambda \in \left(-\frac{3}{2}, \frac{3}{2}\right)$ 61. $x = 0, y = 0$
 62. $\frac{ud}{\sqrt{v^2 - u^2}}$ 64. (2)
 65. 0.50 66. (5) 67. (5)
 68. (4) 69. (9) 70. (5) 71. (9)
 72. (2) 73. (1) 74. (2) 75. (7)

Hints & Solutions

Topic 1 Equations of Tangent and Normal

1. Equation of given curve is

$$y = \frac{x}{x^2 - 3}, x \in R, (x \neq \pm \sqrt{3}) \quad \dots(i)$$

On differentiating Eq. (i) w.r.t. x , we get

$$\frac{dy}{dx} = \frac{(x^2 - 3) - x(2x)}{(x^2 - 3)^2} = \frac{(-x^2 - 3)}{(x^2 - 3)^2}$$

It is given that tangent at a point $(\alpha, \beta) \neq (0, 0)$ on it is parallel to the line

$$2x + 6y - 11 = 0.$$

$$\therefore \text{Slope of this line} = -\frac{2}{6} = \frac{dy}{dx}\bigg|_{(\alpha, \beta)}$$

$$\Rightarrow -\frac{\alpha^2 + 3}{(\alpha^2 - 3)^2} = -\frac{1}{3}$$

$$\Rightarrow 3\alpha^2 + 9 = \alpha^4 - 6\alpha^2 + 9$$

$$\Rightarrow \alpha^4 - 9\alpha^2 = 0$$

$$\Rightarrow \alpha = 0, -3, 3$$

$$\Rightarrow \alpha = 3 \text{ or } -3, \quad [\because \alpha \neq 0]$$

Now, from Eq. (i),

$$\beta = \frac{\alpha}{\alpha^2 - 3} \Rightarrow \beta = \frac{3}{9 - 3} \text{ or } \frac{-3}{9 - 3} = \frac{1}{2} \text{ or } -\frac{1}{2}$$

248 Application of Derivatives

According to the options, $|6\alpha + 2\beta| = 19$

$$\text{at } (\alpha, \beta) = \left(\pm 3, \pm \frac{1}{2}\right)$$

2. Given curve is $y = f(x) = x^3 - x^2 - 2x$... (i)

$$\text{So, } f(1) = 1 - 1 - 2 = -2$$

$$\text{and } f(-1) = -1 - 1 + 2 = 0$$

Since, slope of a line passing through (x_1, y_1) and

$$(x_2, y_2) \text{ is given by } m = \tan \theta = \frac{y_2 - y_1}{x_2 - x_1}$$

\therefore Slope of line joining points $(1, f(1))$ and

$$(-1, f(-1)) \text{ is } m = \frac{f(1) - f(-1)}{1 - (-1)} = \frac{-2 - 0}{1 + 1} = -1$$

Now, $\frac{dy}{dx} = 3x^2 - 2x - 2$ [differentiating Eq. (i), w.r.t. 'x']

According to the question,

$$\frac{dy}{dx} = m$$

$$\Rightarrow 3x^2 - 2x - 2 = -1 \Rightarrow 3x^2 - 2x - 1 = 0$$

$$\Rightarrow (x-1)(3x+1) = 0 \Rightarrow x = 1, -\frac{1}{3}$$

Therefore, set $S = \left\{-\frac{1}{3}, 1\right\}$.

3. Given curve is $y = x^3 + ax - b$... (i)
passes through point $P(1, -5)$.

$$\therefore -5 = 1 + a - b \Rightarrow b - a = 6 \quad \dots \text{(ii)}$$

and slope of tangent at point $P(1, -5)$ to the curve (i), is

$$m_1 = \left. \frac{dy}{dx} \right|_{(1, -5)} = [3x^2 + a]_{(1, -5)} = a + 3$$

\therefore The tangent having slope $m_1 = a + 3$ at point $P(1, -5)$ is perpendicular to line $-x + y + 4 = 0$, whose slope is $m_2 = 1$.

$$\therefore a + 3 = -1 \Rightarrow a = -4 \quad [\because m_1 m_2 = -1]$$

Now, on substituting $a = -4$ in Eq. (ii), we get $b = 2$

On putting $a = -2$ and $b = 2$ in Eq. (i), we get

$$y = x^3 - 4x - 2$$

Now, from option (2, -2) is the required point which lie on it.

4. The given curve is $y = x^2 - 5x + 5$... (i)

Now, slope of tangent at any point (x, y) on the curve is

$$\frac{dy}{dx} = 2x - 5 \quad \dots \text{(ii)}$$

[on differentiating Eq. (i) w.r.t. x]

\therefore It is given that tangent is parallel to line

$$2y = 4x + 1$$

So, $\frac{dy}{dx} = 2$ [\because slope of line $2y = 4x + 1$ is 2]

$$\Rightarrow 2x - 5 = 2 \Rightarrow 2x = 7 \Rightarrow x = \frac{7}{2}$$

On putting $x = \frac{7}{2}$ in Eq. (i), we get

$$y = \frac{49}{4} - \frac{35}{2} + 5 = \frac{69}{4} - \frac{35}{2} = -\frac{1}{4}$$

Now, equation of tangent to the curve (i) at point $\left(\frac{7}{2}, -\frac{1}{4}\right)$ and having slope 2, is

$$y + \frac{1}{4} = 2 \left(x - \frac{7}{2}\right) \Rightarrow y + \frac{1}{4} = 2x - 7$$

$$\Rightarrow y = 2x - \frac{29}{4} \quad \dots \text{(iii)}$$

On checking all the options, we get the point $\left(\frac{1}{8}, -7\right)$

satisfy the line (iii).

5. The helicopter is nearest to the soldier, if the tangent to the path, $y = x^{3/2} + 7$, ($x \geq 0$) of helicopter at point (x, y) is perpendicular to the line joining (x, y) and the position of soldier $\left(\frac{1}{2}, 7\right)$.

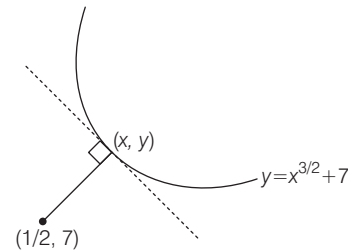

\therefore Slope of tangent at point (x, y) is

$$\frac{dy}{dx} = \frac{3}{2} x^{1/2} = m_1 \text{ (let)} \quad \dots \text{(i)}$$

and slope of line joining (x, y) and $\left(\frac{1}{2}, 7\right)$ is

$$m_2 = \frac{y - 7}{x - \frac{1}{2}} \quad \dots \text{(ii)}$$

Now, $m_1 \cdot m_2 = -1$

$$\Rightarrow \frac{3}{2} x^{1/2} \left(\frac{y - 7}{x - (1/2)}\right) = -1 \quad \text{[from Eqs. (i) and (ii)]}$$

$$\Rightarrow \frac{3}{2} x^{1/2} \frac{x^{3/2} - 7}{x - \frac{1}{2}} = -1 \quad [\because y = x^{3/2} + 7]$$

$$\Rightarrow \frac{3}{2} x^2 = -x + \frac{1}{2}$$

$$\Rightarrow 3x^2 + 2x - 1 = 0 \Rightarrow 3x^2 + 3x - x - 1 = 0$$

$$\Rightarrow 3x(x+1) - 1(x+1) = 0$$

$$\Rightarrow x = \frac{1}{3}, -1 \Rightarrow x \geq 0 \Rightarrow x = \frac{1}{3}$$

and So, $y = \left(\frac{1}{3}\right)^{3/2} + 7$ [$\because y = x^{3/2} + 7$]

Thus, the nearest point is $\left(\frac{1}{3}, \left(\frac{1}{3}\right)^{3/2} + 7\right)$

Now, the nearest distance

$$= \sqrt{\left(\frac{1}{2} - \frac{1}{3}\right)^2 + \left(7 - \left(\frac{1}{3}\right)^{3/2} - 7\right)^2} = \sqrt{\left(\frac{1}{6}\right)^2 + \left(\frac{1}{3}\right)^3}$$

$$= \sqrt{\frac{1}{36} + \frac{1}{27}} = \sqrt{\frac{3+4}{108}} = \sqrt{\frac{7}{108}} = \frac{1}{6} \sqrt{\frac{7}{3}}$$

6. **Key Idea** Angle between two curves is the angle between the tangents to the curves at the point of intersection.

Given equation of curves are

$$y = 10 - x^2 \quad \dots(i)$$

and $y = 2 + x^2 \quad \dots(ii)$

For point of intersection, consider

$$\begin{aligned} 10 - x^2 &= 2 + x^2 \\ \Rightarrow 2x^2 &= 8 \\ \Rightarrow x^2 &= 4 \\ \Rightarrow x &= \pm 2 \end{aligned}$$

Clearly, when $x = 2$, then $y = 6$ (using Eq. (i)) and when $x = -2$, then $y = 6$

Thus, the point of intersection are $(2, 6)$ and $(-2, 6)$.

Let m_1 be the slope of tangent to the curve (i) and m_2 be the slope of tangent to the curve (ii)

For curve (i) $\frac{dy}{dx} = -2x$ and for curve (ii) $\frac{dy}{dx} = 2x$

\therefore At $(2, 6)$, slopes $m_1 = -4$ and $m_2 = 4$, and in that case

$$|\tan \theta| = \frac{|m_2 - m_1|}{|1 + m_1 m_2|} = \frac{|4 + 4|}{|1 - 16|} = \frac{8}{15}$$

At $(-2, 6)$, slopes $m_1 = 4$ and $m_2 = -4$ and in that case

$$|\tan \theta| = \frac{|m_2 - m_1|}{|1 + m_1 m_2|} = \frac{|-4 - 4|}{|1 - 16|} = \frac{8}{15}$$

7. We have, $y^2 = 6x$

$$\Rightarrow 2y \frac{dy}{dx} = 6 \Rightarrow \frac{dy}{dx} = \frac{3}{y}$$

Slope of tangent at (x_1, y_1) is $m_1 = \frac{3}{y_1}$

Also, $9x^2 + by^2 = 16$

$$\Rightarrow 18x + 2by \frac{dy}{dx} = 0 \Rightarrow \frac{dy}{dx} = \frac{-9x}{by}$$

Slope of tangent at (x_1, y_1) is $m_2 = \frac{-9x_1}{by_1}$

Since, these are intersection at right angle.

$$\therefore m_1 m_2 = -1 \Rightarrow \frac{27x_1}{by_1^2} = 1$$

$$\Rightarrow \frac{27x_1}{6bx_1} = 1 \quad [\because y_1^2 = 6x_1]$$

$$\Rightarrow b = \frac{9}{2}$$

8. Given curve is

$$y(x-2)(x-3) = x+6 \quad \dots(i)$$

Put $x = 0$ in Eq. (i), we get

$$y(-2)(-3) = 6 \Rightarrow y = 1$$

So, point of intersection is $(0, 1)$.

Now, $y = \frac{x+6}{(x-2)(x-3)}$

$$\Rightarrow \frac{dy}{dx} = \frac{1(x-2)(x-3) - (x+6)(x-3+x-2)}{(x-2)^2(x-3)^2}$$

$$\Rightarrow \left(\frac{dy}{dx}\right)_{(0,1)} = \frac{6+30}{4 \times 9} = \frac{36}{36} = 1$$

\therefore Equation of normal at $(0, 1)$ is given by

$$y - 1 = \frac{-1}{1}(x - 0) \Rightarrow x + y - 1 = 0$$

which passes through the point $\left(\frac{1}{2}, \frac{1}{2}\right)$.

9. We have, $f(x) = \tan^{-1} \sqrt{\frac{1 + \sin x}{1 - \sin x}}$, $x \in \left(0, \frac{\pi}{2}\right)$

$$\begin{aligned} \Rightarrow f(x) &= \tan^{-1} \frac{\left(\cos \frac{x}{2} + \sin \frac{x}{2}\right)^2}{\left(\cos \frac{x}{2} - \sin \frac{x}{2}\right)^2} \\ &= \tan^{-1} \left(\frac{\cos \frac{x}{2} + \sin \frac{x}{2}}{\cos \frac{x}{2} - \sin \frac{x}{2}}\right) \\ &\quad \left(\because \cos \frac{x}{2} > \sin \frac{x}{2} \text{ for } 0 < \frac{x}{2} < \frac{\pi}{4}\right) \end{aligned}$$

$$\begin{aligned} &= \tan^{-1} \left(\frac{1 + \tan \frac{x}{2}}{1 - \tan \frac{x}{2}}\right) \\ &= \tan^{-1} \left[\tan \left(\frac{\pi}{4} + \frac{x}{2}\right)\right] = \frac{\pi}{4} + \frac{x}{2} \end{aligned}$$

$$\Rightarrow f'(x) = \frac{1}{2} \Rightarrow f'\left(\frac{\pi}{6}\right) = \frac{1}{2}$$

Now, equation of normal at $x = \frac{\pi}{6}$ is given by

$$\begin{aligned} \left(y - f\left(\frac{\pi}{6}\right)\right) &= -2 \left(x - \frac{\pi}{6}\right) \\ \Rightarrow \left(y - \frac{\pi}{3}\right) &= -2 \left(x - \frac{\pi}{6}\right) \left[\because f\left(\frac{\pi}{6}\right) = \frac{\pi}{4} + \frac{\pi}{12} = \frac{4\pi}{12} = \frac{\pi}{3}\right] \end{aligned}$$

which passes through $\left(0, \frac{2\pi}{3}\right)$.

10. Given equation of curve is

$$x^2 + 2xy - 3y^2 = 0 \quad \dots(i)$$

On differentiating w.r.t x , we get

$$2x + 2xy' + 2y - 6yy' = 0 \Rightarrow y' = \frac{x+y}{3y-x}$$

At $x = 1, y = 1, y' = 1$

i.e. $\left(\frac{dy}{dx}\right)_{(1,1)} = 1$

Equation of normal at $(1, 1)$ is

$$y - 1 = -\frac{1}{1}(x - 1) \Rightarrow y - 1 = -(x - 1)$$

$$\Rightarrow x + y = 2 \quad \dots(ii)$$

On solving Eqs. (i) and (ii) simultaneously, we get

$$\Rightarrow x^2 + 2x(2-x) - 3(2-x)^2 = 0$$

250 Application of Derivatives

$$\begin{aligned} \Rightarrow x^2 + 4x - 2x^2 - 3(4 + x^2 - 4x) &= 0 \\ \Rightarrow -x^2 + 4x - 12 - 3x^2 + 12x &= 0 \\ \Rightarrow -4x^2 + 16x - 12 &= 0 \\ \Rightarrow 4x^2 - 16x + 12 &= 0 \\ \Rightarrow x^2 - 4x + 3 &= 0 \\ \Rightarrow (1-1)(x-3) = 0 \Rightarrow x = 1, 3 \end{aligned}$$

Now, when $x = 1$, then $y = 1$

and when $x = 3$, then $y = -1$

$\therefore P = (1, 1)$ and $Q = (3, -1)$

Hence, normal meets the curve again at $(3, -1)$ in fourth quadrant.

Alternate Solution

Given, $x^2 + 2xy - 3y^2 = 0$

$$\Rightarrow (x - y)(x + 3y) = 0$$

$$\Rightarrow x - y = 0 \text{ or } x + 3y = 0$$

Equation of normal at $(1, 1)$ is

$$y - 1 = -1(x - 1) \Rightarrow x + y - 2 = 0$$

It intersects $x + 3y = 0$ at $(3, -1)$ and hence normal meets the curve in fourth quadrant.

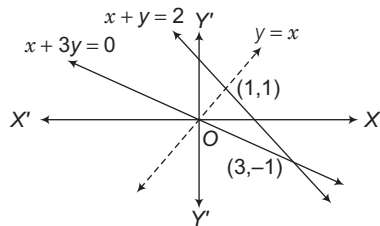

11. Given, $y^3 + 3x^2 = 12y$... (i)

On differentiating w.r.t. x , we get

$$\Rightarrow 3y^2 \frac{dy}{dx} + 6x = 12 \frac{dy}{dx}$$

$$\Rightarrow \frac{dy}{dx} = \frac{6x}{12 - 3y^2} \Rightarrow \frac{dx}{dy} = \frac{12 - 3y^2}{6x}$$

For vertical tangent, $\frac{dx}{dy} = 0$

$$\Rightarrow 12 - 3y^2 = 0 \Rightarrow y = \pm 2$$

On putting, $y = 2$ in Eq. (i), we get $x = \pm \frac{4}{\sqrt{3}}$ and again

putting $y = -2$ in Eq. (i), we get $3x^2 = -16$, no real solution.

So, the required point is $\left(\pm \frac{4}{\sqrt{3}}, 2\right)$.

12. Slope of tangent $y = f(x)$ is $\frac{dy}{dx} = f'(x)_{(3, 4)}$

Therefore, slope of normal

$$= -\frac{1}{f'(x)_{(3, 4)}} = -\frac{1}{f'(3)}$$

But $-\frac{1}{f'(3)} = \tan\left(\frac{3\pi}{4}\right)$ [given]

$$\Rightarrow \frac{-1}{f'(3)} = \tan\left(\frac{\pi}{2} + \frac{\pi}{4}\right) = -1$$

$$\therefore f'(3) = 1$$

13. Given, $x = a(\cos\theta + \theta\sin\theta)$

and $y = a(\sin\theta - \theta\cos\theta)$

$$\therefore \frac{dx}{d\theta} = a(-\sin\theta + \sin\theta + \theta\cos\theta) = a\theta\cos\theta$$

and $\frac{dy}{d\theta} = a(\cos\theta - \cos\theta + \theta\sin\theta)$

$$\frac{dy}{d\theta} = a\theta\sin\theta \Rightarrow \frac{dy}{dx} = \tan\theta$$

Thus, equation of normal is

$$\frac{y - a(\sin\theta - \theta\cos\theta)}{x - a(\cos\theta + \theta\sin\theta)} = \frac{-\cos\theta}{\sin\theta}$$

$$\Rightarrow -x\cos\theta + a\theta\sin\theta\cos\theta + a\cos^2\theta$$

$$= y\sin\theta + \theta a\sin\theta\cos\theta - a\sin^2\theta$$

$$\Rightarrow x\cos\theta + y\sin\theta = a$$

whose distance from origin is

$$\frac{|0 + 0 - a|}{\sqrt{\cos^2\theta + \sin^2\theta}} = a$$

14. Given, $4x^2 + 9y^2 = 1$... (i)

On differentiating w.r.t. x , we get

$$8x + 18y \frac{dy}{dx} = 0 \Rightarrow \frac{dy}{dx} = -\frac{8x}{18y} = -\frac{4x}{9y}$$

The tangent at point (h, k) will be parallel to $8x = 9y$, then

$$-\frac{4h}{9k} = \frac{8}{9} \Rightarrow h = -2k$$

Point (h, k) also lies on the ellipse.

$$\therefore 4h^2 + 9k^2 = 1$$
 ... (ii)

On putting value of h in Eq. (ii), we get

$$4(-2k)^2 + 9k^2 = 1 \Rightarrow 16k^2 + 9k^2 = 1$$

$$\Rightarrow 25k^2 = 1 \Rightarrow k^2 = \frac{1}{25}$$

$$\Rightarrow k = \pm \frac{1}{5}$$

Thus, the point, where the tangents are parallel to

$$8x = 9y \text{ are } \left(-\frac{2}{5}, \frac{1}{5}\right) \text{ and } \left(\frac{2}{5}, -\frac{1}{5}\right).$$

Therefore, options (b) and (d) are the answers.

15. Given, $xy = 1 \Rightarrow y = \frac{1}{x}$

$$\Rightarrow \frac{dy}{dx} = -\frac{1}{x^2}$$

Thus, slope of normal $= x^2$ (which is always positive) and it is given $ax + by + c = 0$ is normal, whose slope $= -\frac{a}{b}$.

$$\Rightarrow -\frac{a}{b} > 0 \text{ or } \frac{a}{b} < 0$$

Hence, a and b are of opposite sign.

16. Given, $y^3 - 3xy + 2 = 0$

On differentiating w.r.t. x , we get

$$3y^2 \frac{dy}{dx} - 3x \frac{dy}{dx} - 3y = 0$$

$$\Rightarrow \frac{dy}{dx} (3y^2 - 3x) = 3y \Rightarrow \frac{dy}{dx} = \frac{3y}{3y^2 - 3x}$$

For the points where tangent is horizontal, the slope of tangent is zero.

i.e. $\frac{dy}{dx} = 0 \Rightarrow \frac{3y}{3y^2 - 3x} = 0$

$\Rightarrow y = 0$ but $y = 0$ does not satisfy the given equation of the curve, therefore y cannot lie on the curve.

So, $H = \phi$ [null set]

For the points where tangent is vertical, $\frac{dy}{dx} = \infty$

$$\Rightarrow \frac{y}{y^2 - x} = \infty$$

$$\Rightarrow y^2 - x = 0 \Rightarrow y^2 = x$$

On putting this value in the given equation of the curve, we get

$$y^3 - 3 \cdot y^2 \cdot y + 2 = 0 \Rightarrow -2y^3 + 2 = 0$$

$$\Rightarrow y^3 - 1 = 0 \Rightarrow y^3 = 1$$

$$\Rightarrow y = 1, x = 1$$

Then, $V = \{1, 1\}$

17. As $|f(x_1) - f(x_2)| \leq (x_1 - x_2)^2, \forall x_1, x_2 \in R$

$$\Rightarrow |f(x_1) - f(x_2)| \leq |x_1 - x_2|^2 \quad [\text{as } x^2 = |x|^2]$$

$$\therefore \left| \frac{f(x_1) - f(x_2)}{x_1 - x_2} \right| \leq |x_1 - x_2|$$

$$\Rightarrow \lim_{x_1 \rightarrow x_2} \left| \frac{f(x_1) - f(x_2)}{x_1 - x_2} \right| \leq \lim_{x_1 \rightarrow x_2} |x_1 - x_2|$$

$$\Rightarrow |f'(x_1)| \leq 0, \forall x_1 \in R$$

$$\therefore |f'(x)| \leq 0, \text{ which shows } |f'(x)| = 0$$

[as modulus is non negative or $|f'(x)| \geq 0$]

$\therefore f'(x) = 0$ or $f(x)$ is constant function.

\Rightarrow Equation of tangent at $(1, 2)$ is

$$\frac{y-2}{x-1} = f'(x) \text{ or } y-2=0 \quad [\because \text{as } f'(x) = 0]$$

$\Rightarrow y-2=0$ is required equation of tangent.

18. Given, $y = ax^3 + bx^2 + cx + 5$ touches X-axis at $P(-2, 0)$ which implies that X-axis is tangent at $(-2, 0)$ and the curve is also passes through $(-2, 0)$.

The curve cuts Y-axis at $(0, 5)$ and gradient at this point is given 3, therefore at $(0, 5)$ slope of the tangent is 3.

Now, $\frac{dy}{dx} = 3ax^2 + 2bx + c$

Since, X-axis is tangent at $(-2, 0)$.

$$\therefore \left. \frac{dy}{dx} \right|_{x=-2} = 0$$

$$\Rightarrow 0 = 3a(-2)^2 + 2b(-2) + c$$

$$\Rightarrow 0 = 12a - 4b + c \quad \dots(i)$$

Again, slope of tangent at $(0, 5)$ is 3.

$$\therefore \left. \frac{dy}{dx} \right|_{(0,5)} = 3$$

$$\Rightarrow 3 = 3a(0)^2 + 2b(0) + c$$

$$\Rightarrow 3 = c \quad \dots(ii)$$

Since, the curve passes through $(-2, 0)$.

$$0 = a(-2)^3 + b(-2)^2 + c(-2) + 5$$

$$\Rightarrow 0 = -8a + 4b - 2c + 5 \quad \dots(iii)$$

From Eqs. (i) and (ii),

$$12a - 4b = -3 \quad \dots(iv)$$

From Eqs. (ii) and (iii),

$$-8a + 4b = 1 \quad \dots(v)$$

On adding Eqs. (iv) and (v), we get

$$4a = -2 \Rightarrow a = -1/2$$

On putting $a = -1/2$ in Eq. (iv), we get

$$12(-1/2) - 4b = -3 \Rightarrow -6 - 4b = -3$$

$$\Rightarrow -3 = 4b \Rightarrow b = -3/4$$

$$\therefore a = -1/2, b = -3/4 \text{ and } c = 3$$

19. Let any point P_1 on $y = x^3$ be (h, h^3) .

Then, tangent at P_1 is

$$y - h^3 = 3h^2(x - h) \quad \dots(i)$$

It meets $y = x^3$ at P_2 .

On putting the value of y in Eq. (i), we get

$$x^3 - h^3 = 3h^2(x - h)$$

$$\Rightarrow (x - h)(x^2 + xh + h^2) = 3h^2(x - h)$$

$$\Rightarrow x^2 + xh + h^2 = 3h^2 \text{ or } x = h$$

$$\Rightarrow x^2 + xh - 2h^2 = 0$$

$$\Rightarrow (x - h)(x + 2h) = 0$$

$$\Rightarrow x = h \text{ or } x = -2h$$

Therefore, $x = -2h$ is the point P_2 ,

which implies $y = -8h^3$

Hence, point $P_2 \equiv (-2h, -8h^3)$

Again, tangent at P_2 is $y + 8h^3 = 3(-2h)^2(x + 2h)$.

It meets $y = x^3$ at P_3

$$\Rightarrow x^3 + 8h^3 = 12h^2(x + 2h)$$

$$\Rightarrow x^2 - 2hx - 8h^2 = 0$$

$$\Rightarrow (x + 2h)(x - 4h) = 0 \Rightarrow x = 4h$$

$$\Rightarrow y = 64h^3$$

Therefore, $P_3 \equiv (4h, 64h^3)$

Similarly, we get $P_4 \equiv (-8h, -8^3 h^3)$

Hence, the abscissae are $h, -2h, 4h, -8h, \dots$, which form a GP.

Let $D' = \Delta P_1 P_2 P_3$ and $D'' = \Delta P_2 P_3 P_4$

$$\frac{D'}{D''} = \frac{\Delta P_1 P_2 P_3}{\Delta P_2 P_3 P_4} = \frac{\frac{1}{2} \begin{vmatrix} h & h^3 & 1 \\ -2h & -8h^3 & 1 \\ 4h & 64h^3 & 1 \end{vmatrix}}{\frac{1}{2} \begin{vmatrix} -2h & -8h^3 & 1 \\ 4h & 64h^3 & 1 \\ -8h & -512h^3 & 1 \end{vmatrix}}$$

252 Application of Derivatives

$$= \frac{\frac{1}{2} \begin{vmatrix} h & h^3 & 1 \\ -2h & -8h^3 & 1 \\ 4h & 64h^3 & 1 \end{vmatrix}}{\frac{1}{2} \times (-2) \times (-8) \begin{vmatrix} h & h^3 & 1 \\ -2h & -8h^3 & 1 \\ 4h & 64h^3 & 1 \end{vmatrix}}$$

$$\Rightarrow \frac{D'}{D''} = \frac{1}{16} = 1 : 16 \text{ which is the required ratio.}$$

20. Given, $y = (1+x)^y + \sin^{-1}(\sin^2 x)$

Let $y = u + v$, where $u = (1+x)^y$, $v = \sin^{-1}(\sin^2 x)$.
On differentiating w.r.t. x , we get

$$\frac{dy}{dx} = \frac{du}{dx} + \frac{dv}{dx} \quad \dots(i)$$

Now, $u = (1+x)^y$

On taking logarithm both sides, we get

$$\log_e u = y \log_e (1+x)$$

$$\Rightarrow \frac{1}{u} \frac{du}{dx} = \frac{y}{1+x} + \frac{dy}{dx} \{\log_e (1+x)\}$$

$$\Rightarrow \frac{du}{dx} = (1+x)^y \left[\frac{y}{1+x} + \frac{dy}{dx} \log_e (1+x) \right] \quad \dots(ii)$$

Again, $v = \sin^{-1}(\sin^2 x) \Rightarrow \sin v = \sin^2 x$

$$\Rightarrow \cos v \frac{dv}{dx} = 2 \sin x \cos x$$

$$\Rightarrow \frac{dv}{dx} = \frac{1}{\cos v} (2 \sin x \cos x)$$

$$\Rightarrow \frac{dv}{dx} = \frac{2 \sin x \cos x}{\sqrt{1 - \sin^2 v}} = \frac{2 \sin x \cos x}{\sqrt{1 - \sin^4 x}} \quad \dots(iii)$$

From Eq. (i),

$$\frac{dy}{dx} = (1+x)^y \left[\frac{y}{1+x} + \frac{dy}{dx} \log_e (1+x) \right] + \frac{2 \sin x \cos x}{\sqrt{1 - \sin^4 x}}$$

$$\Rightarrow \frac{dy}{dx} = \frac{y(1+x)^{y-1} + 2 \sin x \cos x / \sqrt{1 - \sin^4 x}}{1 - (1+x)^y \log_e (1+x)}$$

At $x=0$,

$$y = (1+0)^y + \sin^{-1} \sin(0) = 1$$

$$\therefore \frac{dy}{dx} = \frac{1(1+0)^{1-1} + 2 \sin 0 \cdot \cos 0 / \sqrt{1 - \sin^4 0}}{1 - (1+0)^1 \log_e (1+0)}$$

$$\Rightarrow \frac{dy}{dx} = 1$$

Again, the slope of the normal is

$$m = -\frac{1}{dy/dx} = -1$$

Hence, the required equation of the normal is

$$y - 1 = (-1)(x - 0) \text{ i.e. } y + x - 1 = 0$$

21. Given, $y = \cos(x+y)$

$$\Rightarrow \left(\frac{dy}{dx} \right) = -\sin(x+y) \cdot \left(1 + \frac{dy}{dx} \right) \quad \dots(i)$$

Since, tangent is parallel to $x + 2y = 0$,

$$\text{then slope } \frac{dy}{dx} = -\frac{1}{2}$$

$$\text{From Eq. (i), } -\frac{1}{2} = -\sin(x+y) \cdot \left(1 - \frac{1}{2} \right)$$

$$\Rightarrow \sin(x+y) = 1, \text{ which shows } \cos(x+y) = 0.$$

$$\therefore y = 0$$

$$\Rightarrow x + y = \frac{\pi}{2} \text{ or } -\frac{3\pi}{2}$$

$$\therefore x = \frac{\pi}{2} \text{ or } -\frac{3\pi}{2}$$

Thus, required points are $\left(\frac{\pi}{2}, 0 \right)$ and $\left(-\frac{3\pi}{2}, 0 \right)$

\therefore Equation of tangents are

$$\frac{y-0}{x-\pi/2} = -\frac{1}{2} \text{ and } \frac{y-0}{x+3\pi/2} = -\frac{1}{2}$$

$$\Rightarrow 2y = -x + \frac{\pi}{2} \text{ and } 2y = -x - \frac{3\pi}{2}$$

$$\Rightarrow x + 2y = \frac{\pi}{2} \text{ and } x + 2y = -\frac{3\pi}{2}$$

are the required equations of tangents.

22. Slope of tangent at the point (x_1, y_1) is $\left(\frac{dy}{dx} \right)_{(x_1, y_1)}$.

Given curve, $(y - x^5)^2 = x(1 + x^2)^2$

$$\Rightarrow 2(y - x^5) \left(\frac{dy}{dx} - 5x^4 \right) = (1 + x^2)^2 + 2x(1 + x^2) \cdot 2x$$

Put $x=1$ and $y=3$, $dy/dx=8$

Topic 2 Increasing and Decreasing Functions

1. Let the thickness of layer of ice is x cm, the volume of spherical ball (only ice layer) is

$$V = \frac{4}{3} \pi [(10+x)^3 - 10^3] \quad \dots(i)$$

On differentiating Eq. (i) w.r.t. ' t ', we get

$$\frac{dV}{dt} = \frac{4}{3} \pi (3(10+x)^2) \frac{dx}{dt} = -50 \quad [\text{given}]$$

[–ve sign indicate that volume is decreasing as time passes].

$$\Rightarrow 4\pi(10+x)^2 \frac{dx}{dt} = -50$$

At $x=5$ cm

$$\frac{dx}{dt} [4\pi(10+5)^2] = -50$$

$$\Rightarrow \frac{dx}{dt} = -\frac{50}{225(4\pi)} = -\frac{1}{9(2\pi)} = -\frac{1}{18\pi} \text{ cm/min}$$

So, the thickness of the ice decreases at the rate of $\frac{1}{18\pi}$ cm/min.

2. The given functions are

$$f(x) = e^x - x,$$

$$\text{and } g(x) = x^2 - x, \forall x \in R$$

Then, $h(x) = (f \circ g)(x) = f(g(x))$

Now, $h'(x) = f'(g(x)) \cdot g'(x)$
 $= (e^{g(x)} - 1) \cdot (2x - 1) = (e^{x^2 - x} - 1)(2x - 1)$
 $= (e^{x(x-1)} - 1)(2x - 1)$

\therefore It is given that $h(x)$ is an increasing function, so $h'(x) \geq 0$

$\Rightarrow (e^{x(x-1)} - 1)(2x - 1) \geq 0$

Case I $(2x - 1) \geq 0$ and $(e^{x(x-1)} - 1) \geq 0$

$\Rightarrow x \geq \frac{1}{2}$ and $x(x - 1) \geq 0$

$\Rightarrow x \in [1/2, \infty)$ and $x \in (-\infty, 0] \cup [1, \infty)$, so $x \in [1, \infty)$

Case II $(2x - 1) \leq 0$ and $[e^{x(x-1)} - 1] \leq 0$

$\Rightarrow x \leq \frac{1}{2}$ and $x(x - 1) \leq 0 \Rightarrow x \in \left(-\infty, \frac{1}{2}\right]$ and $x \in [0, 1]$

So, $x \in \left[0, \frac{1}{2}\right]$

From, the above cases, $x \in \left[0, \frac{1}{2}\right] \cup [1, \infty)$.

3. Key Idea Use formula :

Volume of cone = $\frac{1}{3} \pi r^2 h$, where r = radius and h = height of the cone.

Given, semi-vertical angle of right circular cone

$= \tan^{-1}\left(\frac{1}{2}\right)$

Let $\alpha = \tan^{-1}\left(\frac{1}{2}\right)$

$\Rightarrow \tan \alpha = \frac{1}{2}$

$\Rightarrow \frac{r}{h} = \frac{1}{2}$ [from fig. $\tan \alpha = \frac{r}{h}$]

$\Rightarrow r = \frac{1}{2}h$... (i)

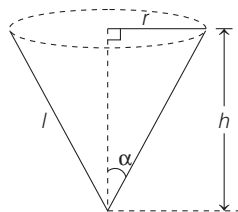

\therefore Volume of cone is $(V) = \frac{1}{3} \pi r^2 h$

$\therefore V = \frac{1}{3} \pi \left(\frac{1}{2}h\right)^2 (h) = \frac{1}{12} \pi h^3$ [from Eq. (i)]

On differentiating both sides w.r.t. 't', we get

$\frac{dV}{dt} = \frac{1}{12} \pi (3h^2) \frac{dh}{dt} \Rightarrow \frac{dh}{dt} = \frac{4}{\pi h^2} \frac{dV}{dt}$

$\Rightarrow \frac{dh}{dt} = \frac{4}{\pi h^2} \times 5$ [\because given $\frac{dV}{dt} = 5 \text{ m}^3/\text{min}$]

Now, at $h = 10 \text{ m}$, the rate at which height of water level is rising = $\left. \frac{dh}{dt} \right|_{h=10} = \frac{4}{\pi(10)^2} \times 5 = \frac{1}{5\pi} \text{ m/min}$

4. Given, $\phi(x) = f(x) + f(2 - x), \forall x \in (0, 2)$
 $\Rightarrow \phi'(x) = f'(x) - f'(2 - x)$... (i)

Also, we have $f''(x) > 0 \forall x \in (0, 2)$

$\Rightarrow f'(x)$ is a strictly increasing function $\forall x \in (0, 2)$.

Now, for $\phi(x)$ to be increasing, $\phi'(x) \geq 0$

$\Rightarrow f'(x) - f'(2 - x) \geq 0$ [using Eq. (i)]

$\Rightarrow f'(x) \geq f'(2 - x) \Rightarrow x > 2 - x$

[$\because f'$ is a strictly increasing function]

$\Rightarrow 2x > 2 \Rightarrow x > 1$

Thus, $\phi(x)$ is increasing on $(1, 2)$.

Similarly, for $\phi(x)$ to be decreasing,

$\phi'(x) \leq 0$
 $\Rightarrow f'(x) - f'(2 - x) \leq 0$

[using Eq. (i)]

$\Rightarrow f'(x) \leq f'(2 - x)$

$\Rightarrow x < 2 - x$ [$\because f'$ is a strictly increasing function]

$\Rightarrow 2x < 2$

$\Rightarrow x < 1$ Thus, $\phi(x)$ is decreasing on $(0, 1)$.

5. Given that function, $f(x) = x^3 - 3(a - 2)x^2 + 3ax + 7$, for some $a \in R$ is increasing in $(0, 1]$ and decreasing in $[1, 5)$.

$f'(1) = 0$ [\because tangent at $x = 1$ will be parallel to X-axis]

$\Rightarrow (3x^2 - 6(a - 2)x + 3a)_{x=1} = 0$

$\Rightarrow 3 - 6(a - 2) + 3a = 0$

$\Rightarrow 3 - 6a + 12 + 3a = 0$

$\Rightarrow 15 - 3a = 0 \Rightarrow a = 5$

So, $f(x) = x^3 - 9x^2 + 15x + 7$

$\Rightarrow f(x) - 14 = x^3 - 9x^2 + 15x - 7$

$\Rightarrow f(x) - 14 = (x - 1)(x^2 - 8x + 7) = (x - 1)(x - 1)(x - 7)$

$\Rightarrow \frac{f(x) - 14}{(x - 1)^2} = (x - 7)$... (i)

Now, $\frac{f(x) - 14}{(x - 1)^2} = 0, (x \neq 1)$

$\Rightarrow x - 7 = 0$ [from Eq. (i)]

$\Rightarrow x = 7$

6. We have,

$f(x) = \frac{x}{(a^2 + x^2)^{1/2}} - \frac{(d - x)}{(b^2 + (d - x)^2)^{1/2}}$

Differentiating above w.r.t. x , we get

$f'(x) = \frac{(a^2 + x^2)^{1/2} - x \frac{1}{2} \frac{2x}{(a^2 + x^2)^{3/2}}}{(a^2 + x^2)^2} - \frac{(b^2 + (d - x)^2)^{1/2}(-1) - (d - x) \frac{2(d - x)(-1)}{2(b^2 + (d - x)^2)^{3/2}}}{(b^2 + (d - x)^2)^2}$

[by using quotient rule of derivative]

254 Application of Derivatives

$$= \frac{a^2 + x^2 - x^2}{(a^2 + x^2)^{3/2}} + \frac{b^2 + (d-x)^2 - (d-x)^2}{(b^2 + (d-x)^2)^{3/2}}$$

$$= \frac{a^2}{(a^2 + x^2)^{3/2}} + \frac{b^2}{(b^2 + (d-x)^2)^{3/2}} > 0, \quad \forall x \in R$$

Hence, $f(x)$ is an increasing function of x .

7. Given, $g(u) = 2 \tan^{-1}(e^u) - \frac{\pi}{2}$ for $u \in (-\infty, \infty)$

$$g(-u) = 2 \tan^{-1}(e^{-u}) - \frac{\pi}{2}$$

$$= 2(\cot^{-1}(e^u)) - \frac{\pi}{2}$$

$$= 2\left(\frac{\pi}{2} - \tan^{-1}(e^u)\right) - \frac{\pi}{2}$$

$$= \pi/2 - 2 \tan^{-1}(e^u) = -g(u)$$

$$\therefore g(-u) = -g(u)$$

$\Rightarrow g(u)$ is an odd function.

We have, $g(u) = 2 \tan^{-1}(e^u) - \pi/2$

$$g'(u) = \frac{2e^u}{1+e^{2u}}$$

$$g'(u) > 0, \quad \forall x \in R \quad [:\ e^u > 0]$$

So, $g'(u)$ is increasing for all $x \in R$.

8. Given, $f(x) = x^3 + bx^2 + cx + d$
 $\Rightarrow f'(x) = 3x^2 + 2bx + c$

As we know that, if $ax^2 + bx + c > 0, \forall x$, then $a > 0$ and $D < 0$.

$$\text{Now, } D = 4b^2 - 12c = 4(b^2 - c) - 8c$$

[where, $b^2 - c < 0$ and $c > 0$]

$$\therefore D = (-ve) \text{ or } D < 0$$

$$\Rightarrow f'(x) = 3x^2 + 2bx + c > 0 \quad \forall x \in (-\infty, \infty)$$

[as $D < 0$ and $a > 0$]

Hence, $f(x)$ is strictly increasing function.

9. Let $f(x) = 3 \sin x - 4 \sin^3 x = \sin 3x$

The longest interval in which $\sin x$ is increasing is of length π .

So, the length of largest interval in which $f(x) = \sin 3x$ is increasing is $\frac{\pi}{3}$.

10. Given, $f(x) = xe^{x(1-x)}$

$$\Rightarrow f'(x) = e^{x(1-x)} + xe^{x(1-x)}(1-2x)$$

$$= e^{x(1-x)} [1 + x(1-2x)]$$

$$= e^{x(1-x)} (1 + x - 2x^2)$$

$$= -e^{x(1-x)} (2x^2 - x - 1)$$

$$= -e^{x(1-x)} (x-1)(2x+1)$$

which is positive in $\left(-\frac{1}{2}, 1\right)$.

Therefore, $f(x)$ is increasing in $\left[-\frac{1}{2}, 1\right]$.

11. **PLAN** Inequation based upon uncompatible function. This type of inequation can be solved by calculus only.

Option (a) Let $f(x) = e^x - 1 - x$.

then $f'(x) = e^x - 1 > 0, \forall x \in (0, 1)$

$\Rightarrow f(x)$ increase in $(0, 1)$

$\Rightarrow f(x) > f(0)$ for $0 < x < 1$

$\Rightarrow e^x - 1 - x > 0$ or $e^x > 1 + x$ for $0 < x < 1$

Option (b) Let $g(x) = \log_e(1+x) - x, 0 < x < 1$

$$g'(x) = \frac{1}{1+x} - 1 = -\frac{x}{1+x} < 0 \text{ for } 0 < x < 1$$

$\Rightarrow g(x)$ decreases for $0 < x < 1$

$\Rightarrow g(x) < g(0)$ for $0 < x < 1$

$\Rightarrow \log_e(1+x) - x < 0$ for $0 < x < 1$

or $\log_e(1+x) < x$ for $0 < x < 1$

Therefore, option (b) is the answer.

Option (c) $\sin x > x$

Let $h(x) = \sin x - x \Rightarrow h'(x) = \cos x - 1$

For $x \in (0, 1)$, $\cos x - 1 < 0$

$\Rightarrow h(x)$ is decreasing function.

$\Rightarrow h(x) < h(0)$

$\Rightarrow \sin x - x < 0$

$\Rightarrow \sin x < x$, which is not true.

Option (d) $p(x) = \log x - x$

$$p'(x) = \frac{1}{x} - 1 > 0, \forall x \in (0, 1)$$

Therefore, $p'(x)$ is an increasing function.

$\Rightarrow p(0) < p(x) < p(1)$

$\Rightarrow -\infty < \log x - x < -1$

$\Rightarrow \log x - x < 0$

$\Rightarrow \log x < x$

Therefore, option (d) is not the answer.

12. Let $f(x) = \int e^x (x-1)(x-2) dx$

$$\Rightarrow f'(x) = e^x (x-1)(x-2)$$

$$\begin{array}{ccc} + & - & + \\ & 1 & 2 \end{array}$$

$\therefore f'(x) < 0$ for $1 < x < 2$

$\Rightarrow f(x)$ is decreasing for $x \in (1, 2)$.

13. Given, $f(x) = \sin^4 x + \cos^4 x$

On differentiating w.r.t. x , we get

$$f'(x) = 4 \sin^3 x \cos x - 4 \cos^3 x \sin x$$

$$= 4 \sin x \cos x (\sin^2 x - \cos^2 x)$$

$$= 2 \sin 2x (-\cos 2x) = -\sin 4x$$

Now, $f'(x) > 0$, if $\sin 4x < 0$

$\Rightarrow \pi < 4x < 2\pi$

$$\Rightarrow \frac{\pi}{4} < x < \frac{\pi}{2} \quad \dots(i)$$

\Rightarrow Option (a) is not proper subset of Eq. (i), so it is not correct.

Now,
$$\frac{\pi}{4} < x < \frac{3\pi}{8}$$

Since, option (b) is the proper subset of Eq. (i), so it is correct.

14. Given, $g(x) = \frac{x}{\tan x}$, where $0 < x \leq 1$

Now, $g(x)$ is continuous in $[0, 1]$ and differentiable in $]0, 1[$.

For $0 < x < 1$,

$$g'(x) = \frac{\tan x - x \sec^2 x}{\tan^2 x}$$

Again, $H(x) = \tan x - x \sec^2 x$, $0 \leq x \leq 1$

Now, $H(x)$ is continuous in $[0, 1]$ and differentiable in $]0, 1[$.

For $0 < x < 1$, $H(x) = \tan x - x \sec^2 x$, $0 \leq x \leq 1$

$$\Rightarrow H'(x) = \sec^2 x - \sec^2 x - 2x \sec^2 x \tan x = -2x \sec^2 x \tan x < 0$$

Hence, $H(x)$ is decreasing function in $[0, 1]$.

Thus, $H(x) < H(0)$ for $0 < x < 1$

$$\Rightarrow H(x) < 0 \quad \text{for } 0 < x < 1$$

$$\Rightarrow g'(x) < 0 \quad \text{for } 0 < x < 1$$

$\Rightarrow g(x)$ is decreasing function in $(0, 1]$.

Therefore, $g(x) = \frac{x}{\tan x}$ is a decreasing function in

$0 < x \leq 1$.

Also, $g(x) < g(0)$ for $0 < x \leq 1$

$$\Rightarrow \frac{x}{\tan x} < 1 \quad \text{for } 0 < x \leq 1$$

$$\Rightarrow x < \tan x \quad \text{for } 0 < x \leq 1$$

Now, let
$$f(x) = \begin{cases} x/\sin x & \text{for } 0 < x \leq 1 \\ 1 & \text{for } x = 0 \end{cases}$$

Now, f is continuous in $[0, 1]$ and differentiable in $]0, 1[$.

For $0 < x < 1$,

$$f'(x) = \frac{\sin x - x \cos x}{\sin^2 x} = \frac{(\tan x - x) \cos x}{\sin^2 x} > 0 \text{ for } 0 < x < 1$$

$\Rightarrow f(x)$ increases in $[0, 1]$.

Thus, $f(x) = \frac{x}{\sin x}$ increases in $0 < x \leq 1$.

Therefore, option (c) is the answer.

15. Given, $f(x) = \frac{\log(\pi + x)}{\log(e + x)}$

$$f'(x) = \frac{\log(e + x) \cdot \frac{1}{\pi + x} - \log(\pi + x) \cdot \frac{1}{e + x}}{[\log(e + x)]^2} \quad \dots(i)$$

When $x > 0$, $\pi + x > e + x$

$$\therefore \log(\pi + x) > \log(e + x) \quad \dots(ii)$$

and
$$\frac{1}{e + x} > \frac{1}{\pi + x} \quad \dots(iii)$$

On multiplying Eqs. (ii) and (iii), we get

$$\frac{\log(\pi + x)}{e + x} > \frac{\log(e + x)}{\pi + x} \quad \dots(iv)$$

From Eqs. (i) and (iv), $f'(x) < 0$

$\therefore f(x)$ is decreasing for $x \in (0, \infty)$.

16. Let $F(x) = h(x) - h(1) = f\{g(x)\} - f\{g(1)\}$

$$\therefore F'(x) = f'\{g(x)\} \cdot g'(x) = (+)(-) = -ve$$

[since, $f(x)$ is an increasing function $f'(g(x))$ is +ve and $g(x)$ is decreasing function $g'(f(x))$ is -ve]

Since, $f'(x)$ is -ve.

$\therefore f(x)$ is decreasing function.

When $0 \leq x < 1 \Rightarrow h(x) - h(1) = +ve$

When $x \geq 1 \Rightarrow h(x) - h(1) = -ve$

Hence, for $x > 0$,

$h(x) - h(1)$ is neither always positive nor always negative, so it is not strictly increasing throughout.

Therefore, option (d) is the answer.

17. $f'(x) > 2f(x) \Rightarrow \frac{dy}{y} > 2dx \Rightarrow \int_1^{f(x)} \frac{dy}{y} > 2 \int_0^x dx$

$$\ln(f(x)) > 2x \Rightarrow f(x) > e^{2x}$$

Also, as $f'(x) > 2f(x)$

$$\Rightarrow f'(x) > 2e^{2x} > 0$$

18. Given, $f(x) = \int_x^x \frac{e^{-\left(t+\frac{1}{t}\right)}}{t} dt$

$$f'(x) = 1 \cdot \frac{e^{-\left(x+\frac{1}{x}\right)}}{x} - \left(\frac{-1}{x^2}\right) \frac{e^{-\left(\frac{1}{x}+x\right)}}{1/x} = \frac{e^{-\left(x+\frac{1}{x}\right)}}{x} + \frac{e^{-\left(x+\frac{1}{x}\right)}}{x} = \frac{2e^{-\left(x+\frac{1}{x}\right)}}{x}$$

As $f'(x) > 0$, $\forall x \in (0, \infty)$

$\therefore f(x)$ is monotonically increasing on $(0, \infty)$.

\Rightarrow Option (a) is correct and option (b) is wrong.

$$\text{Now, } f(x) + f\left(\frac{1}{x}\right) = \int_{1/x}^x \frac{e^{-\left(t+\frac{1}{t}\right)}}{t} dt + \int_x^{1/x} \frac{e^{-\left(t+\frac{1}{t}\right)}}{t} dt = 0, \forall x \in (0, \infty)$$

Now, let
$$g(x) = f(2^x) = \int_{2^{-x}}^{2^x} \frac{e^{-\left(t+\frac{1}{t}\right)}}{t} dt$$

$$g(-x) = f(2^{-x}) = \int_{2^x}^{2^{-x}} \frac{e^{-\left(t+\frac{1}{t}\right)}}{t} dt = -g(x)$$

$\therefore f(2^x)$ is an odd function.

256 Application of Derivatives

19. Given, $h(x) = f(x) - f(x)^2 + f(x)^3$

On differentiating w.r.t. x , we get

$$\begin{aligned} h'(x) &= f'(x) - 2f(x) \cdot f'(x) + 3f^2(x) \cdot f'(x) \\ &= f'(x)[1 - 2f(x) + 3f^2(x)] \\ &= 3f'(x) \left[f(x)^2 - \frac{2}{3}f(x) + \frac{1}{3} \right] \\ &= 3f'(x) \left[\left(f(x) - \frac{1}{3} \right)^2 + \frac{1}{3} - \frac{1}{9} \right] \\ &= 3f'(x) \left[\left(f(x) - \frac{1}{3} \right)^2 + \frac{3-1}{9} \right] \\ &= 3f'(x) \left[\left(f(x) - \frac{1}{3} \right)^2 + \frac{2}{9} \right] \end{aligned}$$

NOTE $h'(x) < 0$, if $f'(x) < 0$ and $h'(x) > 0$, if $f'(x) > 0$

Therefore, $h(x)$ is an increasing function, if $f(x)$ is increasing function and $h(x)$ is decreasing function, if $f(x)$ is decreasing function.

Therefore, options (a) and (c) are correct answers.

20. Let $f(x) = \log(1+x) - x$

$$\Rightarrow f'(x) = \frac{1}{1+x} - 1 = -\frac{x}{1+x}$$

$$\Rightarrow f'(x) > 0$$

when $-1 < x < 0$ and $f'(x) < 0$

when $x > 0$

$\therefore f(x)$ is increasing for $-1 < x < 0$.

$$\Rightarrow f(x) < f(0) \Rightarrow \log(1+x) < x$$

Again, $f(x)$ is decreasing for $x > 0$.

$$\Rightarrow f(x) < f(0) \Rightarrow \log(1+x) < x$$

$$\therefore \log(1+x) \leq x, \forall x > -1$$

21. Here, $y = \begin{cases} 2x^2 - \log x, & x > 0 \\ 2x^2 - \log(-x), & x < 0 \end{cases}$

$$\begin{aligned} \Rightarrow \frac{dy}{dx} &= \begin{cases} 4x - \frac{1}{x}, & x > 0 \\ 4x - \frac{1}{x}, & x < 0 \end{cases} \\ &= \frac{4x^2 - 1}{x}, x \in \mathbb{R} - \{0\} = \frac{(2x-1)(2x+1)}{x} \end{aligned}$$

$$\therefore \text{Increasing when } x \in \left(-\frac{1}{2}, 0\right) \cup \left(\frac{1}{2}, \infty\right)$$

$$\text{and decreasing when } x \in \left(-\infty, -\frac{1}{2}\right) \cup \left(0, \frac{1}{2}\right).$$

Solutions. (22-24)

$$f(x) = x + \ln x - x \ln x \Rightarrow f(1) = 1 > 0$$

$$f(e^2) = e^2 + 2 - 2e^2 = 2 - e^2 < 0$$

$$\Rightarrow f(x) = 0 \text{ for some } x \in (1, e^2)$$

\therefore I is correct

$$f'(x) = 1 + \frac{1}{x} - \ln x - 1 = \frac{1}{x} - \ln x$$

$$f'(x) > 0 \text{ for } (0, 1)$$

$$f'(x) < 0 \text{ for } (e, \infty)$$

\therefore P and Q are correct, II is correct, III is incorrect.

$$f''(x) = \frac{-1}{x^2} - \frac{1}{x} \Rightarrow f''(x) < 0 \text{ for } (0, \infty)$$

\therefore S, is correct, R is incorrect.

IV is incorrect.

$$\lim_{x \rightarrow \infty} f(x) = -\infty \Rightarrow \lim_{x \rightarrow \infty} f'(x) = -\infty \Rightarrow \lim_{x \rightarrow \infty} f''(x) = 0$$

\therefore ii, iii, iv are correct.

22. (d) 23. (c)

24. (c)

25. $\frac{d}{dx}(x + \sin x) = 1 + \cos x = 2 \cos^2 \frac{x}{2} > 0$ for $-\frac{\pi}{2} < x < \frac{\pi}{2}$.

Therefore, $x + \sin x$ is increasing in the given interval. Therefore, (A) \rightarrow (p) is the answer.

Again, $\frac{d}{dx}(\sec x) = \sec x \tan x$ which is > 0 for $0 < x < \pi/2$

and < 0 for $-\frac{\pi}{2} < x < 0$

Therefore, $\sec x$ is neither increasing nor decreasing in the given interval. Therefore, (B) \rightarrow (r) is the answer.

26. Let $f(x) = \sin x + 2x - \frac{3x(x+1)}{\pi}$

On differentiating w.r.t. x , we get

$$\Rightarrow f'(x) = \cos x + 2 - \frac{(6x+3)}{\pi}$$

$$\Rightarrow f''(x) = -\sin x - \frac{6}{\pi} < 0, \forall x \in \left[0, \frac{\pi}{2}\right]$$

$$\therefore f'(x) \text{ is decreasing for all } x \in \left[0, \frac{\pi}{2}\right]$$

$$\Rightarrow f'(x) > 0 \quad [\because x < \pi/2]$$

$$\Rightarrow f'(x) > f'(\pi/2)$$

$\therefore f(x)$ is increasing.

Thus, when $x \geq 0$, $f(x) \geq f(0)$

$$\Rightarrow \sin x + 2x - \frac{3x(x+1)}{\pi} \geq 0 \Rightarrow \sin x + 2x \geq \frac{3x(x+1)}{\pi}$$

27. Let $f(x) = \sin(\tan x) - x$

$$f'(x) = \cos(\tan x) \cdot \sec^2 x - 1$$

$$= \cos(\tan x)(1 + \tan^2 x) - 1$$

$$= \tan^2 x \{\cos(\tan x)\} + \cos(\tan x) - 1$$

$$> \tan^2 x \cos(\tan x) - \frac{\tan^2 x}{2}$$

$$\left[\begin{aligned} &\because 2(1 - \cos x) < x^2, x \neq 0 \Rightarrow \cos x > 1 - \frac{x^2}{2} \\ &\Rightarrow \cos(\tan x) > 1 - \frac{\tan^2 x}{2} \end{aligned} \right]$$

$$f'(x) > \tan^2 x \left[\cos(\tan x) - \frac{1}{2} \right]$$

$$> \tan^2 x [\cos(\tan x) - \cos(\pi/3)] > 0$$

$\Rightarrow f(x)$ is increasing function, for all $x \in [0, \pi/4]$
 As $f(0) = 0 \Rightarrow f(x) \geq 0$, for all $x \in [0, \pi/4]$
 $\Rightarrow \sin(\tan x) \geq x$

28. Given, $-1 \leq p \leq 1$

Let $f(x) = 4x^3 - 3x - p = 0$

Now, $f(1/2) = \frac{1}{2} - \frac{3}{2} - p = -1 - p \leq 0$ [$\because p \geq -1$]

Also, $f(1) = 4 - 3 - p = 1 - p \geq 0$ [$\because p \leq 1$]

$\therefore f(x)$ has atleast one real root between $[1/2, 1]$.

Also, $f'(x) = 12x^2 - 3 > 0$ on $[1/2, 1]$

$\Rightarrow f'(x)$ increasing on $[1/2, 1]$

$\Rightarrow f$ has only one real root between $[1/2, 1]$.

To find a root, we observe $f(x)$ contains $4x^3 - 3x$, which is multiple angle formula for $\cos 3\theta$.

\therefore Put $x = \cos \theta$

$\Rightarrow 4 \cos^3 \theta - 3 \cos \theta - p = 0$

$\Rightarrow p = \cos 3\theta \Rightarrow \theta = (1/3) \cos^{-1}(p)$

\therefore Root is $\cos\left(\frac{1}{3} \cos^{-1}(p)\right)$.

29. **NOTE** This type is asked in 1983 and repeat after 13 years.

At $x=0$, LHL = $\lim_{x \rightarrow 0^-} f(x) = \lim_{x \rightarrow 0^-} xe^{ax} = 0$

and RHL = $\lim_{x \rightarrow 0^+} f(x) = \lim_{x \rightarrow 0^+} (x + ax^2 - x^3) = 0$

Therefore, LHL = RHL = $0 = f(0)$

So, $f(x)$ is continuous at $x=0$.

Also, $f'(x) = \begin{cases} 1 \cdot e^{ax} + axe^{ax}, & \text{if } x < 0 \\ 1 + 2ax - 3x^2, & \text{if } x > 0 \end{cases}$

and $Lf'(0) = \lim_{x \rightarrow 0^-} \frac{f(x) - f(0)}{x - 0}$
 $= \lim_{x \rightarrow 0^-} \frac{xe^{ax} - 0}{x} = \lim_{x \rightarrow 0^-} e^{ax} = e^0 = 1$

and $Rf'(0) = \lim_{x \rightarrow 0^+} \frac{f(x) - f(0)}{x + 0}$
 $= \lim_{x \rightarrow 0^+} \frac{x + ax^2 - x^3 - 0}{x}$
 $= \lim_{x \rightarrow 0^+} 1 + ax - x^2 = 1$

Therefore, $Lf'(0) = Rf'(0) = 1 \Rightarrow f'(0) = 1$

Hence, $f'(x) = \begin{cases} (ax+1)e^{ax}, & \text{if } x < 0 \\ 1, & \text{if } x = 0 \\ 1 + 2ax - 3x^2, & \text{if } x > 0 \end{cases}$

Now, we can say without solving that, $f'(x)$ is continuous at $x=0$ and hence on R . We have,

$f''(x) = \begin{cases} ae^{ax} + a(ax+1)e^{ax}, & \text{if } x < 0 \\ 2a - 6x, & \text{if } x > 0 \end{cases}$

and $Lf''(0) = \lim_{x \rightarrow 0^-} \frac{f'(x) - f'(0)}{x - 0}$
 $= \lim_{x \rightarrow 0^-} \frac{(ax+1)e^{ax} - 1}{x}$

$$\begin{aligned}
 &= \lim_{x \rightarrow 0^-} \left[ae^{ax} + \frac{e^{ax} - 1}{x} \right] \\
 &= \lim_{x \rightarrow 0^-} ae^{ax} + a \cdot \lim_{x \rightarrow 0^-} \frac{e^{ax} - 1}{ax} \\
 &= ae^0 + a(1) = 2a \\
 \text{and } Rf''(0) &= \lim_{x \rightarrow 0^+} \frac{f'(x) - f'(0)}{x + 0} \\
 &= \lim_{x \rightarrow 0^+} \frac{(1 + 2ax - 3x^2) - 1}{x} \\
 &= \lim_{x \rightarrow 0^+} \frac{2ax - 3x^2}{x} = \lim_{x \rightarrow 0^+} 2a - 3x = 2a
 \end{aligned}$$

Therefore, $Lf''(0) = Rf''(0) = 2a$

Hence, $f''(x) = \begin{cases} a(ax+2)e^{ax}, & \text{if } x < 0 \\ 2a, & \text{if } x = 0 \\ 2a - 6x, & \text{if } x > 0 \end{cases}$

Now, for $x < 0$, $f''(x) > 0$, if $ax + 2 > 0$

\Rightarrow For $x < 0$, $f''(x) > 0$, if $x > -2/a$

$\Rightarrow f'(x) > 0$, if $-\frac{2}{a} < x < 0$

and for $x > 0$, $f''(x) > 0$, if $2a - 6x > 0$

\Rightarrow for $x > 0$, $f''(x) > 0$, if $x < a/3$

Thus, $f(x)$ increases on $[-2/a, 0]$ and on $[0, a/3]$.

Hence, $f(x)$ increases on $\left[-\frac{2}{a}, \frac{a}{3}\right]$

30. Let $y = f(x) = 2 \sin x + 2 \tan x - 3x$

$\Rightarrow f'(x) = 2 \cos x + 2 \sec^2 x - 3$

For $0 \leq x < \pi/2$, $f'(x) > 0$

Thus, $f(x)$ is increasing.

When $x \geq 0$, $f(x) \geq f(0)$

$\Rightarrow 2 \sin x + 2 \tan x - 3x \geq 0 + 0 - 0$

$\Rightarrow 2 \sin x + 2 \tan x \geq 3x$

31. Let $f(x) = 1 + x \log(x + \sqrt{x^2 + 1}) - \sqrt{1 + x^2}$

$$\begin{aligned}
 \therefore f'(x) &= x \cdot \frac{\left(1 + \frac{x}{\sqrt{x^2 + 1}}\right)}{x + \sqrt{x^2 + 1}} + \log(x + \sqrt{x^2 + 1}) \\
 &\quad - \frac{x}{\sqrt{x^2 + 1}} = \frac{x}{\sqrt{x^2 + 1}} + \log(x + \sqrt{x^2 + 1}) - \frac{x}{\sqrt{x^2 + 1}}
 \end{aligned}$$

$\Rightarrow f'(x) = \log(x + \sqrt{x^2 + 1})$

$\Rightarrow f'(x) \geq 0$ [$\because \log(x + \sqrt{x^2 + 1}) \geq 0$]

$\therefore f(x)$ is increasing for $x \geq 0$.

$\Rightarrow f(x) \geq f(0)$

$\Rightarrow 1 + x \log(x + \sqrt{1 + x^2}) - \sqrt{1 + x^2} \geq 1 + 0 - 1$

$\Rightarrow 1 + x \log(x + \sqrt{1 + x^2}) \geq \sqrt{1 + x^2}, \forall x \geq 0$

32. Given, $A = \left\{x: \frac{\pi}{6} \leq x \leq \frac{\pi}{3}\right\}$

258 Application of Derivatives

$$\text{and } f(x) = \cos x - x - x^2$$

$$\Rightarrow f'(x) = -\sin x - 1 - 2x = -(\sin x + 1 + 2x)$$

$$\text{which is negative for } x \in \left[\frac{\pi}{6}, \frac{\pi}{3} \right] \Rightarrow f'(x) < 0$$

or $f(x)$ is decreasing.

$$\begin{aligned} \text{Hence, } f(A) &= \left[f\left(\frac{\pi}{3}\right), f\left(\frac{\pi}{6}\right) \right] \\ &= \left[\frac{1}{2} - \frac{\pi}{3} \left(1 + \frac{\pi}{3}\right), \frac{\sqrt{3}}{2} - \frac{\pi}{6} \left(1 + \frac{\pi}{6}\right) \right] \end{aligned}$$

Topic 3 Rolle's and Lagrange's Theorem

1. $f'(x)$ is increasing

$$\text{For some } x \text{ in } \left(\frac{1}{2}, 1 \right)$$

$$\begin{aligned} f'(x) &= 1 && \text{[LMVT]} \\ \therefore f'(1) &> 1 \end{aligned}$$

2. Given, $f(x) = 2 + \cos x, \forall x \in R$

Statement I There exists a point $c \in [t, t+r]$, where $f'(c) = 0$

Hence, Statement I is true.

Statement II $f(t) = f(t+2\pi)$ is true. But statement II is not correct explanation for statement I.

3. Since, $f(x)$ and $g(x)$ are differentiable functions for $0 \leq x \leq 1$.

$$\therefore f'(c) = \frac{f(1) - f(0)}{1 - 0}$$

Using Lagrange's Mean Value theorem,

$$\frac{6 - 2}{1 - 0} = 4$$

$$\text{and } g'(c) = \frac{g(1) - g(0)}{1 - 0} = \frac{2 - 0}{1 - 0} = 2$$

$$\Rightarrow f'(c) = 2g'(c)$$

Topic 4 Maxima and Minima

1. Given region is

$$\{(x, y) \in R \times R : 0 \leq x \leq \frac{\pi}{2} \text{ and } 0 \leq y \leq 2 \sin(2x)\}$$

On drawing the diagram,

Let the side PS on the X -axis, such that $P(x, 0)$, and $Q(x, 2 \sin(2x))$, so length of the sides $PS = QR = 2 \left(\frac{\pi}{4} - x \right)$

and $PQ = RS = 2 \sin 2x$.

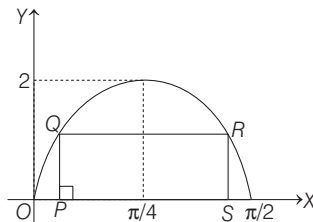

\therefore Perimeter of the rectangle

$$y = 4 \left[\frac{\pi}{4} - x + \sin 2x \right]$$

For maximum, $\frac{dy}{dx} = 0$

$$\Rightarrow -1 + 2 \cos 2x = 0$$

$$\Rightarrow \cos 2x = \frac{1}{2}$$

$$\Rightarrow 2x = \frac{\pi}{3} \Rightarrow x = \frac{\pi}{6} \quad \left\{ \because x \in \left[0, \frac{\pi}{2} \right] \right\}$$

$$\text{and } \left. \frac{d^2y}{dx^2} \right|_{x=\frac{\pi}{6}} = -4 \sin 2x \Big|_{x=\frac{\pi}{6}} < 0$$

\therefore At $x = \frac{\pi}{6}$, the rectangle $PQRS$ have maximum perimeter.

So length of sides

$$PS = QR = 2 \left(\frac{\pi}{4} - \frac{\pi}{6} \right) = \frac{\pi}{6}$$

$$\text{and } PQ = RS = 2 \sin \left(\frac{\pi}{3} \right) = \sqrt{3}$$

$$\therefore \text{ Required area} = \frac{\pi}{6} \times \sqrt{3} = \frac{\pi}{2\sqrt{3}}$$

2. Given functions are $f(x) = 5 - |x - 2|$

and $g(x) = |x + 1|$, where $x \in R$.

Clearly, maximum of $f(x)$ occurred at $x = 2$, so $\alpha = 2$.

and minimum of $g(x)$ occurred at $x = -1$, so $\beta = -1$.

$$\Rightarrow \alpha\beta = -2$$

$$\text{Now, } \lim_{x \rightarrow -\alpha\beta} \frac{(x-1)(x^2-5x+6)}{x^2-6x+8}$$

$$= \lim_{x \rightarrow 2} \frac{(x-1)(x-3)(x-2)}{(x-4)(x-2)} \quad [\because \alpha\beta = -2]$$

$$= \lim_{x \rightarrow 2} \frac{(x-1)(x-3)}{(x-4)} = \frac{(2-1)(2-3)}{(2-4)} = \frac{1 \times (-1)}{(-2)} = \frac{1}{2}$$

- 3.

Key Idea Volume of parallelopiped formed by the vectors \mathbf{a} , \mathbf{b} and \mathbf{c} is $V = |\mathbf{a} \cdot \mathbf{b} \times \mathbf{c}|$.

Given vectors are $\hat{\mathbf{i}} + \lambda\hat{\mathbf{j}} + \hat{\mathbf{k}}$, $\hat{\mathbf{j}} + \lambda\hat{\mathbf{k}}$ and $\lambda\hat{\mathbf{i}} + \hat{\mathbf{k}}$, which forms a parallelopiped.

\therefore Volume of the parallelopiped is

$$V = \left| \begin{vmatrix} 1 & \lambda & 1 \\ 0 & 1 & \lambda \\ \lambda & 0 & 1 \end{vmatrix} \right| = 1 + \lambda^3 - \lambda$$

$$\Rightarrow V = \lambda^3 - \lambda + 1$$

On differentiating w.r.t. λ , we get

$$\frac{dV}{d\lambda} = 3\lambda^2 - 1$$

For maxima or minima, $\frac{dV}{d\lambda} = 0$

$$\Rightarrow \lambda = \pm \frac{1}{\sqrt{3}}$$

and $\frac{d^2V}{d\lambda^2} = 6\lambda = \begin{cases} 2\sqrt{3} > 0, & \text{for } \lambda = \frac{1}{\sqrt{3}} \\ 2\sqrt{3} < 0, & \text{for } \lambda = -\frac{1}{\sqrt{3}} \end{cases}$

$\therefore \frac{d^2V}{d\lambda^2}$ is positive for $\lambda = \frac{1}{\sqrt{3}}$, so volume 'V' is minimum for $\lambda = \frac{1}{\sqrt{3}}$

4. Given function $f(x) = x\sqrt{kx - x^2}$... (i)

the function $f(x)$ is defined if $kx - x^2 \geq 0$

$\Rightarrow x^2 - kx \leq 0$

$\Rightarrow x \in [0, k]$... (ii)

because it is given that $f(x)$ is increasing in interval $x \in [0, 3]$, so k should be positive.

Now, on differentiating the function $f(x)$ w.r.t. x , we get

$$f'(x) = \sqrt{kx - x^2} + \frac{x}{2\sqrt{kx - x^2}} \times (k - 2x)$$

$$= \frac{2(kx - x^2) + kx - 2x^2}{2\sqrt{kx - x^2}} = \frac{3kx - 4x^2}{2\sqrt{kx - x^2}}$$

as $f(x)$ is increasing in interval $x \in [0, 3]$, so

$f'(x) \geq 0 \forall x \in (0, 3)$

$\Rightarrow 3kx - 4x^2 \geq 0$

$\Rightarrow 4x^2 - 3kx \leq 0$

$\Rightarrow 4x \left(x - \frac{3k}{4} \right) \leq 0 \Rightarrow x \in \left[0, \frac{3k}{4} \right]$ (as k is positive)

So, $3 \leq \frac{3k}{4} \Rightarrow k \geq 4$

\Rightarrow Minimum value of $k = m = 4$

and the maximum value of f in $[0, 3]$ is $f(3)$.

$\therefore f$ is increasing function in interval $x \in [0, 3]$

$\therefore M = f(3) = 3\sqrt{4 \times 3 - 3^2} = 3\sqrt{3}$

Therefore, ordered pair $(m, M) = (4, 3\sqrt{3})$

5. The non-zero four degree polynomial $f(x)$ has extremum points at $x = -1, 0, 1$, so we can assume $f'(x) = a(x+1)(x-0)(x-1) = ax(x^2-1)$ where, a is non-zero constant.

$f'(x) = ax^3 - ax$

$\Rightarrow f(x) = \frac{a}{4}x^4 - \frac{a}{2}x^2 + C$

[integrating both sides]

where, C is constant of integration.

Now, since $f(x) = f(0)$

$\Rightarrow \frac{a}{4}x^4 - \frac{a}{2}x^2 + C = C \Rightarrow \frac{x^4}{4} = \frac{x^2}{2}$

$\Rightarrow x^2(x^2 - 2) = 0 \Rightarrow x = -\sqrt{2}, 0, \sqrt{2}$

Thus, $f(x) = f(0)$ has one rational and two irrational roots.

6. **Key Idea**

- (i) Use formula of volume of cylinder, $V = \pi r^2 h$ where, r = radius and h = height
- (ii) For maximum or minimum, put first derivative of V equal to zero

Let a sphere of radius 3, which inscribed a right circular cylinder having radius r and height is h , so

From the figure, $\frac{h}{2} = 3 \cos \theta$

$\Rightarrow h = 6 \cos \theta$

and $r = 3 \sin \theta$... (i)

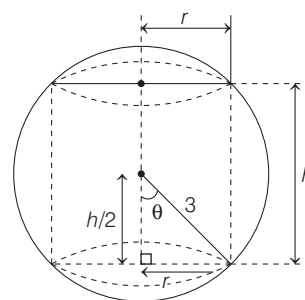

\therefore Volume of cylinder $V = \pi r^2 h$
 $= \pi (3 \sin \theta)^2 (6 \cos \theta) = 54\pi \sin^2 \theta \cos \theta$

For maxima or minima, $\frac{dV}{d\theta} = 0$

$\Rightarrow 54\pi [2 \sin \theta \cos^2 \theta - \sin^3 \theta] = 0$

$\Rightarrow \sin \theta [2 \cos^2 \theta - \sin^2 \theta] = 0$

$\Rightarrow \tan^2 \theta = 2$ $\left[\because \theta \in \left(0, \frac{\pi}{2} \right) \right]$

$\Rightarrow \tan \theta = \sqrt{2} \Rightarrow \sin \theta = \sqrt{\frac{2}{3}}$

and $\cos \theta = \frac{1}{\sqrt{3}}$... (ii)

From Eqs. (i) and (ii), we get

$h = 6 \frac{1}{\sqrt{3}} = 2\sqrt{3}$

7. Given function is

$f(x) = 9x^4 + 12x^3 - 36x^2 + 25 = y$ (let)

For maxima or minima put $\frac{dy}{dx} = 0$

$\Rightarrow \frac{dy}{dx} = 36x^3 + 36x^2 - 72x = 0$

$\Rightarrow x^3 + x^2 - 2x = 0$

$\Rightarrow x[x^2 + x - 2] = 0$

$\Rightarrow x[x^2 + 2x - x - 2] = 0$

$\Rightarrow x[x(x+2) - 1(x+2)] = 0$

$\Rightarrow x(x-1)(x+2) = 0$

$\Rightarrow x = -2, 0, 1$

By sign method, we have following

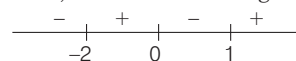

260 Application of Derivatives

Since, $\frac{dy}{dx}$ changes its sign from negative to positive at $x = -2$ and '1', so $x = -2, 1$ are points of local minima. Also, $\frac{dy}{dx}$ changes its sign from positive to negative at $x = 0$, so $x = 0$ is point of local maxima.
 $\therefore S_1 = \{-2, 1\}$ and $S_2 = \{0\}$.

8. Given equation of curve is

$$y^2 = x - 2 \quad \dots(i)$$

and the equation of line is

$$y = x \quad \dots(ii)$$

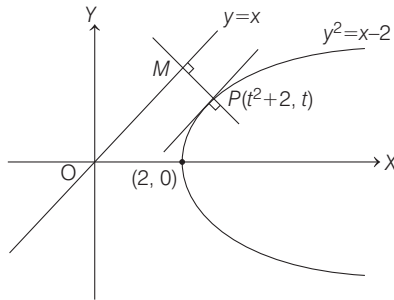

Consider a point $P(t^2 + 2, t)$ on parabola (i). For the shortest distance between curve (i) and line (ii), the line PM should be perpendicular to line (ii) and parabola (i), i.e. tangent at P should be parallel to $y = x$.

$$\therefore \left. \frac{dy}{dx} \right|_{\text{at point } P} = \text{Slope of tangent at point } P \text{ to curve (i)} = 1 \quad [\because \text{tangent is parallel to line } y = x]$$

$$\Rightarrow \left. \frac{1}{2y} \right|_P = 1 \quad [\text{differentiating the curve (i), we get } 2y \frac{dy}{dx} = 1]$$

$$\Rightarrow \frac{1}{2t} = 1 \Rightarrow t = \frac{1}{2} \quad [\because P(x, y) = P(t^2 + 2, t)]$$

So, the point P is $\left(\frac{9}{4}, \frac{1}{2}\right)$.

$$\text{Now, minimum distance} = PM = \frac{\left| \frac{9}{4} - \frac{1}{2} \right|}{\sqrt{2}}$$

[\because distance of a point $P(x_1, y_1)$ from a line

$$ax + by + c = 0 \text{ is } \frac{|ax_1 + by_1 + c|}{\sqrt{a^2 + b^2}} = \frac{7}{4\sqrt{2}} \text{ units}]$$

9. Equation of parabola is given, $y = 12 - x^2$

$$\text{or } x^2 = -(y - 12).$$

Note that vertex of parabola is $(0, 12)$ and its open downward.

Let Q be one of the vertices of rectangle which lies on parabola. Then, the coordinates of Q be $(a, 12 - a^2)$

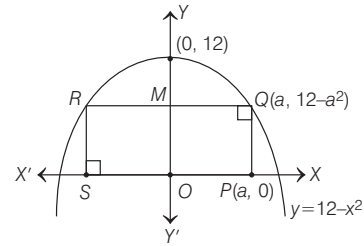

Then, area of rectangle $PQRS$

$$= 2 \times (\text{Area of rectangle } PQMO)$$

[due to symmetry about Y -axis]

$$= 2 \times [a(12 - a^2)] = 24a - 2a^3 = \Delta \text{ (let).}$$

The area function Δ_a will be maximum, when

$$\frac{d\Delta}{da} = 0 \Rightarrow 24 - 6a^2 = 0$$

$$\Rightarrow a^2 = 4 \Rightarrow a = 2 \quad [\because a > 0]$$

So, maximum area of rectangle

$$PQRS = (24 \times 2) - 2(2)^3 = 48 - 16 = 32 \text{ sq units}$$

10. We have,

$$f(x) = 3x^3 - 18x^2 + 27x - 40$$

$$\Rightarrow f'(x) = 9x^2 - 36x + 27$$

$$= 9(x^2 - 4x + 3) = 9(x - 1)(x - 3) \quad \dots(i)$$

Also, we have $S = \{x \in R : x^2 + 30 \leq 11x\}$

Clearly, $x^2 + 30 \leq 11x$

$$\Rightarrow x^2 - 11x + 30 \leq 0$$

$$\Rightarrow (x - 5)(x - 6) \leq 0 \Rightarrow x \in [5, 6]$$

So, $S = [5, 6]$

Note that $f(x)$ is increasing in $[5, 6]$

[$\because f'(x) > 0$ for $x \in [5, 6]$]

$\therefore f(6)$ is maximum, where

$$f(6) = 3(6)^3 - 18(6)^2 + 27(6) - 40 = 122$$

11. According to given information, we have the following figure.

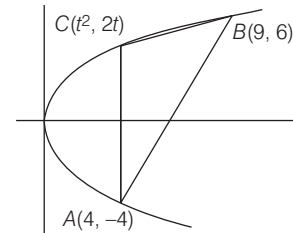

For $y^2 = 4ax$, parametric coordinates of a point is $(at^2, 2at)$.

\therefore For $y^2 = 4x$, let coordinates of C be $(t^2, 2t)$.

$$\text{Then, area of } \Delta ABC = \frac{1}{2} \begin{vmatrix} t^2 & 2t & 1 \\ 9 & 6 & 1 \\ 4 & -4 & 1 \end{vmatrix}$$

$$= \frac{1}{2} |t^2(6 - (-4)) - 2t(9 - 4) + 1(-36 - 24)|$$

$$= \frac{1}{2} |10t^2 - 10t - 60| = \frac{10}{2} |t^2 - t - 6| = 5 |t^2 - t - 6|$$

Let, $A(t) = 5 |t^2 - t - 6|$... (i)

Clearly, $A(4, -4) \equiv A(t_1^2, 2t_1) \Rightarrow 2t_1 = -4$

$\Rightarrow t_1 = -2$

and $B(9, 6) \equiv B(t_2^2, 2t_2) \Rightarrow 2t_2 = 6 \Rightarrow t_2 = 3$

Since, C is on the arc AOB , the parameter ' t ' for point $C \in (-2, 3)$.

Let $f(t) = t^2 - t - 6 \Rightarrow f'(t) = 2t - 1$

Now, $f'(t) = 0 \Rightarrow t = \frac{1}{2}$

Thus, for $A(t)$, critical point is at $t = \frac{1}{2}$

Now, $A\left(\frac{1}{2}\right) = 5 \left| \left(\frac{1}{2}\right)^2 - \frac{1}{2} - 6 \right| = \frac{125}{4} = 31 \frac{1}{4}$ [Using Eq. (i)]

12. Let h = height of the cone, r = radius of circular base

$= \sqrt{(3)^2 - h^2}$ [$\because l^2 = h^2 + r^2$]

$= \sqrt{9 - h^2}$... (i)

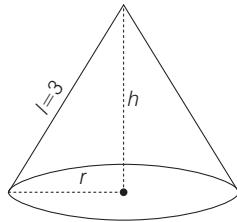

Now, volume (V) of cone $= \frac{1}{3} \pi r^2 h$

$\Rightarrow V(h) = \frac{1}{3} \pi (9 - h^2)h$ [From Eq. (i)]

$= \frac{1}{3} \pi [9h - h^3]$... (ii)

For maximum volume $V'(h) = 0$ and $V''(h) < 0$.

Here, $V'(h) = 0 \Rightarrow (9 - 3h^2) = 0$

$\Rightarrow h = \sqrt{3}$ [$\because h < 0$]

and $V''(h) = \frac{1}{3} \pi (-6h) < 0$ for $h = \sqrt{3}$

Thus, volume is maximum when $h = \sqrt{3}$

Now, maximum volume

$V(\sqrt{3}) = \frac{1}{3} \pi (9\sqrt{3} - 3\sqrt{3})$ [from Eq. (ii)]

$= 2\sqrt{3}\pi$

13. We have,

$f(x) = x^2 + \frac{1}{x^2}$ and $g(x) = x - \frac{1}{x} \Rightarrow h(x) = \frac{f(x)}{g(x)}$

$\therefore h(x) = \frac{x^2 + \frac{1}{x^2}}{x - \frac{1}{x}} = \frac{\left(x - \frac{1}{x}\right)^2 + 2}{x - \frac{1}{x}}$

$\Rightarrow h(x) = \left(x - \frac{1}{x}\right) + \frac{2}{x - \frac{1}{x}}$

$x - \frac{1}{x} > 0, \left(x - \frac{1}{x}\right) + \frac{2}{x - \frac{1}{x}} \in [2\sqrt{2}, \infty)$

$x - \frac{1}{x} < 0, \left(x - \frac{1}{x}\right) + \frac{2}{x - \frac{1}{x}} \in (-\infty, 2\sqrt{2}]$

\therefore Local minimum value is $2\sqrt{2}$.

14. Total length $= 2r + r\theta = 20$

$\Rightarrow \theta = \frac{20 - 2r}{r}$

Now, area of flower-bed,

$A = \frac{1}{2} r^2 \theta$

$\Rightarrow A = \frac{1}{2} r^2 \left(\frac{20 - 2r}{r}\right)$

$\Rightarrow A = 10r - r^2$

$\therefore \frac{dA}{dr} = 10 - 2r$

For maxima or minima, put $\frac{dA}{dr} = 0$.

$\Rightarrow 10 - 2r = 0 \Rightarrow r = 5$

$\therefore A_{\max} = \frac{1}{2} (5)^2 \left[\frac{20 - 2(5)}{5}\right]$

$= \frac{1}{2} \times 25 \times 2 = 25$ sq. m

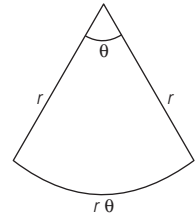

15. According to given information, we have Perimeter of square + Perimeter of circle = 2 units

$\Rightarrow 4x + 2\pi r = 2$

$\Rightarrow r = \frac{1 - 2x}{\pi}$... (i)

Now, let A be the sum of the areas of the square and the circle. Then,

$A = x^2 + \pi r^2 = x^2 + \pi \frac{(1 - 2x)^2}{\pi^2}$

$\Rightarrow A(x) = x^2 + \frac{(1 - 2x)^2}{\pi}$

Now, for minimum value of $A(x)$, $\frac{dA}{dx} = 0$

$\Rightarrow 2x + \frac{2(1 - 2x)}{\pi} \cdot (-2) = 0 \Rightarrow x = \frac{2 - 4x}{\pi}$

$\Rightarrow \pi x + 4x = 2 \Rightarrow x = \frac{2}{\pi + 4}$... (ii)

Now, from Eq. (i), we get

$r = \frac{1 - 2 \cdot \frac{2}{\pi + 4}}{\pi} = \frac{\pi + 4 - 4}{\pi(\pi + 4)} = \frac{1}{\pi + 4}$... (iii)

From Eqs. (ii) and (iii), we get $x = 2r$

16. Here, to find the least value of $\alpha \in R$, for which $4\alpha x^2 + \frac{1}{x} \geq 1$, for all $x > 0$.

i.e. to find the minimum value of α when $y = 4\alpha x^2 + \frac{1}{x}$; $x > 0$ attains minimum value of α .

$\therefore \frac{dy}{dx} = 8\alpha x - \frac{1}{x^2}$... (i)

262 Application of Derivatives

Now, $\frac{d^2y}{dx^2} = 8\alpha + \frac{2}{x^3}$... (ii)

When $\frac{dy}{dx} = 0$ then $8x^3\alpha = 1$

At $x = \left(\frac{1}{8\alpha}\right)^{1/3}$, $\frac{d^2y}{dx^2} = 8\alpha + 16\alpha = 24\alpha$, Thus, y attains minimum when $x = \left(\frac{1}{8\alpha}\right)^{1/3}$; $\alpha > 0$.

$\therefore y$ attains minimum when $x = \left(\frac{1}{8\alpha}\right)^{1/3}$.

i.e. $4\alpha \left(\frac{1}{8\alpha}\right)^{2/3} + (8\alpha)^{1/3} \geq 1$

$\Rightarrow \alpha^{1/3} + 2\alpha^{1/3} \geq 1$

$\Rightarrow 3\alpha^{1/3} \geq 1 \Rightarrow \alpha \geq \frac{1}{27}$

Hence, the least value of α is $\frac{1}{27}$.

- 17. PLAN** Any function have extreme values (maximum or minimum) at its critical points, where $f'(x) = 2$.

Since, the function have extreme values at $x=1$ and $x=2$.

$\therefore f'(x) = 0$ at $x=1$ and $x=2$

$\Rightarrow f'(1) = 0$ and $f'(2) = 0$

Also, it is given that,

$$\lim_{x \rightarrow 0} \left[1 + \frac{f(x)}{x^2} \right] = 3 \Rightarrow 1 + \lim_{x \rightarrow 0} \frac{f(x)}{x^2} = 3$$

$\Rightarrow \lim_{x \rightarrow 0} \frac{f(x)}{x^2} = 2$

$\Rightarrow f(x)$ will be of the form $ax^4 + bx^3 + 2x^2$.

[$\because f(x)$ is of four degree polynomial]

Let $f(x) = ax^4 + bx^3 + 2x^2$

$\Rightarrow f'(x) = 4ax^3 + 3bx^2 + 4x$

$\Rightarrow f'(1) = 4a + 3b + 4 = 0$... (i)

and $f'(2) = 32a + 12b + 8 = 0$

$\Rightarrow 8a + 3b + 2 = 0$... (ii)

On solving Eqs. (i) and (ii),

we get $a = \frac{1}{2}, b = -2$

$\therefore f(x) = \frac{x^4}{2} - 2x^3 + 2x^2$

$\Rightarrow f(2) = 8 - 16 + 8 = 0$

- 18.** Here, $x=-1$ and $x=2$ are extreme points of $f(x) = \alpha \log|x| + \beta x^2 + x$, then

$$f'(x) = \frac{\alpha}{x} + 2\beta x + 1$$

$f'(-1) = -\alpha - 2\beta + 1 = 0$... (i)
[at extreme point, $f'(x) = 0$]

$f'(2) = \frac{\alpha}{2} + 4\beta + 1 = 0$... (ii)

On solving Eqs. (i) and (ii), we get

$$\alpha = 2, \beta = -\frac{1}{2}$$

- 19. PLAN** The given equation contains algebraic and trigonometric functions called transcendental equation. To solve transcendental equations we should always plot the graph for LHS and RHS.

Here, $x^2 = x \sin x + \cos x$

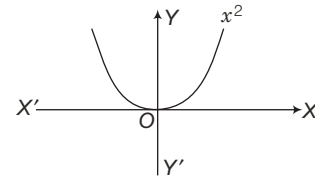

Let $f(x) = x^2$ and $g(x) = x \sin x + \cos x$

We know that, the graph for $f(x) = x^2$

To plot, $g(x) = x \sin x + \cos x$

$$g'(x) = x \cos x + \sin x - \sin x$$

$$g'(x) = x \cos x \quad \dots (i)$$

$$g''(x) = -x \sin x + \cos x \quad \dots (ii)$$

Put $g'(x) = 0 \Rightarrow x \cos x = 0$

$\therefore x = 0, \frac{\pi}{2}, \frac{3\pi}{2}, \frac{5\pi}{2}, \frac{7\pi}{2}$

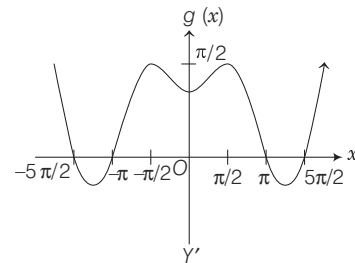

At $x = 0, \frac{3\pi}{2}, \frac{7\pi}{2}, \dots, f''(x) > 0$, so minimum

At $x = \frac{\pi}{2}, \frac{5\pi}{2}, \frac{9\pi}{2}, \dots, f''(x) < 0$, so maximum

So, graph of $f(x)$ and $g(x)$ are shown as

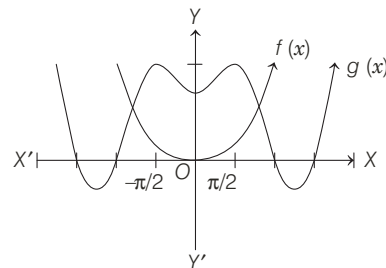

So, number of solutions are 2.

- 20.** Given function, $f(x) = e^{x^2} + e^{-x^2}$, $g(x) = xe^{x^2} + e^{-x^2}$ and

$h(x) = x^2 e^{x^2} + e^{-x^2}$ are strictly increasing on $[0, 1]$.

Hence, at $x=1$, the given function attains absolute maximum all equal to $e + 1/e$.

$\Rightarrow a = b = c$

- 21.** Given, $f(x) = \begin{cases} (2+x)^3, & \text{if } -3 < x \leq -1 \\ x^{2/3}, & \text{if } -1 < x < 2 \end{cases}$

$$\Rightarrow f'(x) = \begin{cases} 3(x+2)^2, & \text{if } -3 < x \leq -1 \\ \frac{2}{3}x^{-\frac{1}{3}}, & \text{if } -1 < x < 2 \end{cases}$$

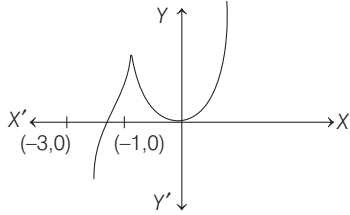

Clearly, $f'(x)$ changes its sign at $x = -1$ from +ve to -ve and so $f(x)$ has local maxima at $x = -1$.

Also, $f'(0)$ does not exist but $f'(0^-) < 0$ and $f'(0^+) < 0$. It can only be inferred that $f(x)$ has a possibility of a minima at $x = 0$. Hence, the given function has one local maxima at $x = -1$ and one local minima at $x = 0$.

22. Given $f(x) = x^2 + 2bx + 2c^2$ and $g(x) = -x^2 - 2cx + b^2$

Then, $f(x)$ is minimum and $g(x)$ is maximum at $\left(x = \frac{-b}{4a}$ and $f(x) = \frac{-D}{4a}\right)$, respectively.

$$\therefore \min f(x) = \frac{-(4b^2 - 8c^2)}{4} = (2c^2 - b^2)$$

$$\text{and } \max g(x) = -\frac{(4c^2 + 4b^2)}{4(-1)} = (b^2 + c^2)$$

Now, $\min f(x) > \max g(x)$

$$\Rightarrow 2c^2 - b^2 > b^2 + c^2$$

$$\Rightarrow c^2 > 2b^2$$

$$\Rightarrow |c| > \sqrt{2}|b|$$

23. It is clear from figure that at $x = 0$, $f(x)$ is not continuous.

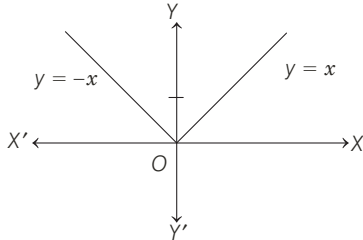

Here, $f(0) > \text{RHL at } x = 0$ and $f(0) > \text{LHL at } x = 0$

So, local maximum at $x = 0$.

24. Given, $f(x) = \frac{x^2 - 1}{x^2 + 1} = 1 - \frac{2}{x^2 + 1}$

$f(x)$ will be minimum, when $\frac{2}{x^2 + 1}$ is maximum,

i.e. when $x^2 + 1$ is minimum,

i.e. at $x = 0$.

\therefore Minimum value of $f(x)$ is $f(0) = -1$

25. The maximum value of $f(x) = \cos x + \cos(\sqrt{2}x)$ is 2 which occurs at $x = 0$. Also, there is no other value of x for which this value will be attained again.

26. Let $f(x) = x^{25}(1-x)^{75}$, $x \in [0, 1]$

$$\begin{aligned} \Rightarrow f'(x) &= 25x^{24}(1-x)^{75} - 75x^{25}(1-x)^{74} \\ &= 25x^{24}(1-x)^{74} [(1-x) - 3x] \\ &= 25x^{24}(1-x)^{74}(1-4x) \end{aligned}$$

For maximum value of $f(x)$, put $f'(x) = 0$

$$\Rightarrow 25x^{24}(1-x)^{74}(1-4x) = 0$$

$$\Rightarrow x = 0, 1, \frac{1}{4}$$

Also, at $x = 0, y = 0$

At $x = 1, y = 0$

and at $x = 1/4, y > 0$

$\therefore f(x)$ attains maximum at $x = 1/4$.

27. Let the coordinates of P be $(a \cos \theta, b \sin \theta)$

Equations of tangents at P is

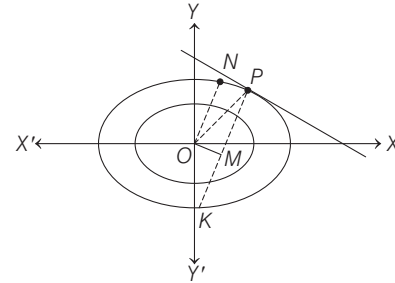

$$\frac{x}{a} \cos \theta + \frac{y}{b} \sin \theta = 1$$

Again, equation of normal at point P is

$$ax \sec \theta - by \operatorname{cosec} \theta = a^2 - b^2$$

Let M be foot of perpendicular from O to PK , the normal at P .

$$\text{Area of } \triangle OPN = \frac{1}{2} (\text{Area of rectangle } OMPN)$$

$$= \frac{1}{2} ON \cdot OM$$

$$\text{Now, } ON = \frac{1}{\sqrt{\frac{\cos^2 \theta}{a^2} + \frac{\sin^2 \theta}{b^2}}} = \frac{ab}{\sqrt{b^2 \cos^2 \theta + a^2 \sin^2 \theta}}$$

[perpendicular from O , to line NP]

$$\text{and } OM = \frac{a^2 - b^2}{\sqrt{a^2 \sec^2 \theta + b^2 \operatorname{cosec}^2 \theta}} = \frac{(a^2 - b^2) \cdot \cos \theta \cdot \sin \theta}{\sqrt{a^2 \sin^2 \theta + b^2 \cos^2 \theta}}$$

$$\begin{aligned} \text{Thus, area of } \triangle OPN &= \frac{ab(a^2 - b^2) \cos \theta \cdot \sin \theta}{2(a^2 \sin^2 \theta + b^2 \cos^2 \theta)} \\ &= \frac{ab(a^2 - b^2) \tan \theta}{2(a^2 \tan^2 \theta + b^2)} \end{aligned}$$

$$\text{Let } f(\theta) = \frac{\tan \theta}{a^2 \tan^2 \theta + b^2} \quad [0 < \theta < \pi/2]$$

$$f'(\theta) = \frac{\sec^2 \theta (a^2 \tan^2 \theta + b^2) - \tan \theta (2a^2 \tan \theta \sec^2 \theta)}{(a^2 \tan^2 \theta + b^2)^2}$$

264 Application of Derivatives

$$\begin{aligned} &= \frac{\sec^2 \theta (a^2 \tan^2 \theta + b^2 - 2a^2 \tan^2 \theta)}{(a^2 \tan^2 \theta + b^2)^2} \\ &= \frac{\sec^2 \theta (a \tan \theta + b)(b - a \tan \theta)}{(a^2 \tan^2 \theta + b^2)^2} \end{aligned}$$

For maximum or minimum, we put

$$f'(\theta) = 0 \Rightarrow b - a \tan \theta = 0$$

$$[\sec^2 \theta \neq 0, a \tan \theta + b \neq 0, 0 < \theta < \pi/2]$$

$$\Rightarrow \tan \theta = b/a$$

$$\text{Also, } f'(\theta) \begin{cases} > 0, \text{ if } 0 < \theta < \tan^{-1}(b/a) \\ < 0, \text{ if } \tan^{-1}(b/a) < \theta < \pi/2 \end{cases}$$

Therefore, $f(\theta)$ has maximum, when

$$\theta = \tan^{-1}\left(\frac{b}{a}\right) \Rightarrow \tan \theta = \frac{b}{a}$$

$$\text{Again, } \sin \theta = \frac{b}{\sqrt{a^2 + b^2}}, \cos \theta = \frac{a}{\sqrt{a^2 + b^2}}$$

By using symmetry, we get the required points

$$\left(\frac{\pm a^2}{\sqrt{a^2 + b^2}}, \frac{\pm b^2}{\sqrt{a^2 + b^2}} \right)$$

- 28.** Given, $P(x) = a_0 + a_1x^2 + a_2x^4 + \dots + a_nx^{2n}$
 where, $a_n > a_{n-1} > a_{n-2} > \dots > a_2 > a_1 > a_0 > 0$
 $\Rightarrow P'(x) = 2a_1x + 4a_2x^3 + \dots + 2na_nx^{2n-1}$
 $= 2x(a_1 + 2a_2x^2 + \dots + na_nx^{2n-2}) \dots(i)$
 where, $(a_1 + 2a_2x^2 + 3a_3x^4 + \dots + na_nx^{2n-2}) > 0, \forall x \in R$.
 Thus, $\begin{cases} P'(x) > 0, & \text{when } x > 0 \\ P'(x) < 0, & \text{when } x < 0 \end{cases}$

i.e. $P'(x)$ changes sign from (-ve) to (+ve) at $x = 0$.

$\therefore P(x)$ attains minimum at $x = 0$.

Hence, it has only one minimum at $x = 0$.

- 29.** $y = a \log x + bx^2 + x$ has extremum at $x = -1$ and $x = 2$.

$$\therefore \frac{dy}{dx} = 0, \text{ at } x = -1$$

$$\text{and } x = 2 \Rightarrow \frac{a}{x} + 2bx + 1 = 0, \text{ at } x = -1$$

$$\text{and } x = 2$$

$$\therefore -a - 2b + 1 = 0 \text{ and } \frac{a}{2} + 4b + 1 = 0$$

$$\Rightarrow a = 2 \text{ and } b = -\frac{1}{2}$$

- 30.** Since, $\max(p, q) = \begin{cases} p, & \text{if } p > q \\ q, & \text{if } q > p \end{cases}$

$$\text{and } \max(p, q, r) = \begin{cases} p, & \text{if } p \text{ is greatest.} \\ q, & \text{if } q \text{ is greatest.} \\ r, & \text{if } r \text{ is greatest.} \end{cases}$$

$\therefore \max(p, q) < \max(p, q, r)$ is false.

$$\text{We know that, } |p - q| = \begin{cases} p - q, & \text{if } p \geq q \\ q - p, & \text{if } p < q \end{cases}$$

$$\therefore \frac{1}{2}(p + q - |p - q|) = \begin{cases} \frac{1}{2}(p + q - p + q), & \text{if } p \geq q \\ \frac{1}{2}(p + q + p - q), & \text{if } p < q \end{cases}$$

$$= \begin{cases} q, & \text{if } p \geq q \\ p, & \text{if } p < q \end{cases}$$

$$\Rightarrow \frac{1}{2}\{p + q - |p - q|\} = \min(p, q)$$

- 31.** Given, $f: R \rightarrow R$ and $f(x) = (x-1)(x-2)(x-5)$

$$\text{Since, } F(x) = \int_0^x f(t) dt, x > 0$$

$$\text{So, } F'(x) = f(x) = (x-1)(x-2)(x-5)$$

According to wavy curve method

$$\begin{array}{ccccccc} & - & & + & & - & & + \\ & & 1 & & 2 & & 5 & & \end{array}$$

$F'(x)$ changes, it's sign from negative to positive at $x = 1$ and 5 , so, $F(x)$ has minima at $x = 1$ and 5 and as $F'(x)$ changes, it's sign from positive to negative at $x = 2$, so $F(x)$ has maxima at $x = 2$.

$$\therefore F(2) = \int_0^2 f(t) dt = \int_0^2 (t^3 - 8t^2 + 17t - 10) dt$$

$$= \left[\frac{t^4}{4} - 8\frac{t^3}{3} + 17\frac{t^2}{2} - 10t \right]_0^2$$

$$= 4 - \frac{64}{3} + 34 - 20 = 38 - \frac{124}{3} = -\frac{10}{3}$$

\therefore At the point of maxima $x = 2$, the functional value $F(2) = -\frac{10}{3}$, is negative for the interval $x \in (0, 5)$, so

$F(x) \neq 0$ for any value of $x \in (0, 5)$,

Hence, options (a), (b) and (d) are correct.

- 32.** Given function $f: R \rightarrow R$ is

$$f(x) = \begin{cases} x^5 + 5x^4 + 10x^3 + 10x^2 + 3x + 1, & x < 0 \\ x^2 - x + 1, & 0 \leq x < 1 \\ \frac{2}{3}x^3 - 4x^2 + 7x - \frac{8}{3}, & 1 \leq x < 3 \\ (x-2) \log_e(x-2) - x + \frac{10}{3}, & x \geq 3 \end{cases}$$

$$\text{So, } f'(x) = \begin{cases} 5x^4 + 20x^3 + 30x^2 + 20x + 3, & x < 0 \\ 2x - 1, & 0 < x < 1 \\ 2x^2 - 8x + 7, & 1 < x < 3 \\ \log_e(x-2), & x > 3 \end{cases}$$

At $x = 1$, $f''(1^-) = 2 > 0$ and $f''(1^+) = 4 - 8 = -4 < 0$

$\therefore f'(x)$ is not differentiable at $x = 1$ and

$f'(x)$ has a local maximum at $x = 1$.

For $x \in (-\infty, 0)$

$$f'(x) = 5x^4 + 20x^3 + 30x^2 + 20x + 3$$

$$\text{and since } f'(-1) = 5 - 20 + 30 - 20 + 3 = -2 < 0$$

So, $f(x)$ is not increasing on $x \in (-\infty, 0)$.

Now, as the range of function $f(x)$ is R , so f is onto function.

Hence, options (b), (c) and (d) are correct.

33.
$$f(x) = \begin{vmatrix} \cos 2x & \cos 2x & \sin 2x \\ -\cos x & \cos x & -\sin x \\ \sin x & \sin x & \cos x \end{vmatrix}$$

$$\begin{aligned} &= \cos 2x(\cos^2 x + \sin^2 x) - \cos 2x \\ &\quad (-\cos^2 x + \sin^2 x) + \sin 2x(-\sin 2x) \\ &= \cos 2x + \cos 4x \\ f'(x) &= -2 \sin 2x - 4 \sin 4x = -2 \sin 2x(1 + 4 \cos 2x) \end{aligned}$$

At $x=0 \Rightarrow f'(x)=0$ and $f(x)=2$
 Also, $f'(x)=0 \Rightarrow \sin 2x=0$
 or $\cos 2x = \frac{-1}{4} \Rightarrow x = \frac{n\pi}{2}$ or $\cos 2x = -\frac{1}{4}$

34. Here, $\lim_{x \rightarrow 2} \frac{f(x) \cdot g(x)}{f'(x) \cdot g'(x)} = 1$
 $\Rightarrow \lim_{x \rightarrow 2} \frac{f(x) g'(x) + f'(x) g(x)}{f''(x) g'(x) + f'(x) g''(x)} = 1$
 [using L' Hospital's rule]
 $\Rightarrow \frac{f(2) g'(2) + f'(2) g(2)}{f''(2) g'(2) + f'(2) g''(2)} = 1$
 $\Rightarrow \frac{f(2) g'(2)}{f''(2) g'(2)} = 1 \quad [\because f'(2) = g(2) = 0]$
 $\Rightarrow f(2) = f''(2) \quad \dots (i)$

$\therefore f(x) - f''(x) = 0$, for atleast one $x \in R$.
 \Rightarrow Option (d) is correct.
 Also, $f: R \rightarrow (0, \infty) \Rightarrow f(2) > 0$
 $\therefore f''(2) = f(2) > 0$ [from Eq. (i)]
 Since, $f'(2) = 0$ and $f''(2) > 0$
 $\therefore f(x)$ attains local minimum at $x = 2$.
 \Rightarrow Option (a) is correct.

35. PLAN

We know that, $|x| = \begin{cases} x, & \text{if } x \geq 0 \\ -x, & \text{if } x < 0 \end{cases}$
 $\Rightarrow |x - a| = \begin{cases} x - a, & \text{if } x \geq a \\ -(x - a), & \text{if } x < a \end{cases}$

and for non-differentiable continuous function, the maximum or minimum can be checked with graph as

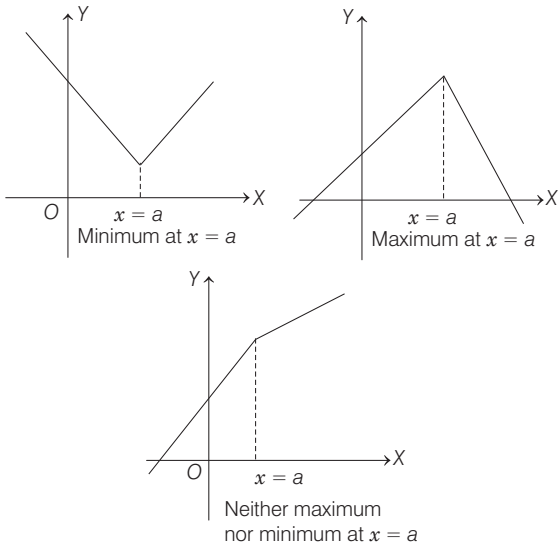

Here, $f(x) = 2|x| + |x+2| - ||x+2| - 2|x||$

$$= \begin{cases} -2x - (x+2) + (x-2), & \text{if } \text{when } x \leq -2 \\ -2x + x + 2 + 3x + 2, & \text{if } \text{when } -2 < x \leq -2/3 \\ -4x, & \text{if } \text{when } -2/3 < x \leq 0 \\ 4x, & \text{if } \text{when } 0 < x \leq 2 \\ 2x + 4, & \text{if } \text{when } x > 2 \end{cases}$$

$$= \begin{cases} -2x - 4, & \text{if } x \leq -2 \\ 2x + 4, & \text{if } -2 < x \leq -2/3 \\ -4x, & \text{if } -2/3 < x \leq 0 \\ 4x, & \text{if } 0 < x \leq 2 \\ 2x + 4, & \text{if } x > 2 \end{cases}$$

Graph for $y = f(x)$ is shown as

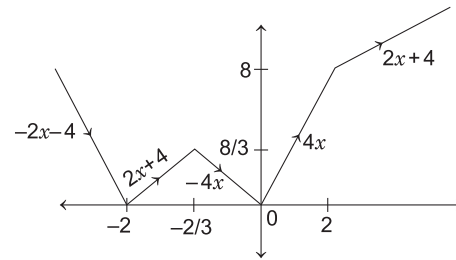

36. PLAN

The problem is based on the concept to maximise volume of cuboid, i.e. to form a function of volume, say $f(x)$ find $f'(x)$ and $f''(x)$.
 Put $f'(x) = 0$ and check $f''(x)$ to be +ve or -ve for minimum and maximum, respectively.

Here, $l = 15x - 2a$, $b = 8x - 2a$ and $h = a$

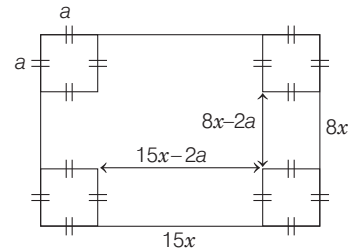

$\therefore \text{Volume} = (8x - 2a)(15x - 2a)a$
 $V = 2a \cdot (4x - a)(15x - 2a) \quad \dots (i)$

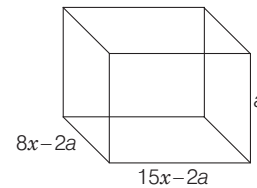

On differentiating Eq. (i) w.r.t a , we get

$$\frac{dv}{da} = 6a^2 - 46ax + 60x^2$$

Again, differentiating,

$$\frac{d^2v}{da^2} = 12a - 46x$$

Here, $\left(\frac{dv}{da}\right) = 0 \Rightarrow 6x^2 - 23x + 15 = 0$

266 Application of Derivatives

At $a = 5 \Rightarrow x = 3, \frac{5}{6}$

$\Rightarrow \left(\frac{d^2v}{da^2}\right) = 2(30 - 23x)$

At $x = 3, \left(\frac{d^2v}{da^2}\right) = 2(30 - 69) < 0$

\therefore Maximum when $x = 3$, also at $x = \frac{5}{6} \Rightarrow \left(\frac{d^2v}{da^2}\right) > 0$

\therefore At $x = 5/6$, volume is minimum.

Thus, sides are $8x = 24$ and $15x = 45$

37. Given,

$$f(x) = \begin{cases} e^x, & \text{if } 0 \leq x \leq 1 \\ 2 - e^{x-1}, & \text{if } 1 < x \leq 2 \\ x - e, & \text{if } 2 < x \leq 3 \end{cases}$$

and $g(x) = \int_0^x f(t) dt$

$\Rightarrow g'(x) = f(x)$

Put $g'(x) = 0 \Rightarrow x = 1 + \log_e 2$ and $x = e$.

Also, $g''(x) = \begin{cases} e^x, & \text{if } 0 \leq x \leq 1 \\ -e^{x-1}, & \text{if } 1 < x \leq 2 \\ 1, & \text{if } 2 < x \leq 3 \end{cases}$

At $x = 1 + \log_e 2$,

$g''(1 + \log_e 2) = -e^{\log_e 2} < 0$, $g(x)$ has a local maximum.

Also, at $x = e$,

$g''(e) = 1 > 0$, $g(x)$ has a local minima.

$\therefore f(x)$ is discontinuous at $x = 1$, then we get local maxima at $x = 1$ and local minima at $x = 2$.

Hence, (a) and (b) are correct answers.

38. Since, $f(x)$ has local maxima at $x = -1$ and $f'(x)$ has local minima at $x = 0$.

$\therefore f''(x) = \lambda x$

On integrating, we get

$$f'(x) = \lambda \frac{x^2}{2} + c \quad [\because f'(-1) = 0]$$

$\Rightarrow \frac{\lambda}{2} + c = 0 \Rightarrow \lambda = -2c \quad \dots(i)$

Again, integrating on both sides, we get

$$f(x) = \lambda \frac{x^3}{6} + cx + d$$

$\Rightarrow f(2) = \lambda \left(\frac{8}{6}\right) + 2c + d = 18 \quad \dots(ii)$

and $f(1) = \frac{\lambda}{6} + c + d = -1 \quad \dots(iii)$

From Eqs. (i), (ii) and (iii),

$$f(x) = \frac{1}{4}(19x^3 - 57x + 34)$$

$\therefore f'(x) = \frac{1}{4}(57x^2 - 57) = \frac{57}{4}(x-1)(x+1)$

For maxima or minima, put $f'(x) = 0 \Rightarrow x = 1, -1$

Now $f''(x) = \frac{1}{4}(114x)$

At $x = 1, f''(x) > 0$, minima

At $x = -1, f''(x) < 0$, maxima

$\therefore f(x)$ is increasing for $[1, 2\sqrt{5}]$.

$\therefore f(x)$ has local maxima at $x = -1$ and $f(x)$ has local minima at $x = 1$.

Also, $f(0) = 34/4$

Hence, (b) and (c) are the correct answers.

39. $f(x) = \int_{-1}^x t(e^t - 1)(t-1)(t-2)^3(t-3)^5 dt$

$$f'(x) = \frac{d}{dx} \int_{-1}^x t(e^t - 1)(t-1)(t-2)^3(t-3)^5 dt$$

$$= x(e^x - 1)(x-1)(x-2)^3(x-3)^5 \times 1$$

$$\left[\because \frac{d}{dx} \int_{\phi(x)}^{\psi(x)} f(t) dt = f(\psi(x))\psi'(x) - f(\phi(x))\phi'(x) \right]$$

For local minimum, $f'(x) = 0$

$\Rightarrow x = 0, 1, 2, 3$

Let $f'(x) = g(x) = x(e^x - 1)(x-1)(x-2)^3(x-3)^5$

Using sign rule,

This shows that $f(x)$ has a local minimum at $x = 1$ and $x = 3$ and maximum at $x = 2$.

Therefore, (b) and (d) are the correct answers.

40. For $-1 \leq x \leq 2$, we have

$$f(x) = 3x^2 + 12x - 1$$

$\Rightarrow f'(x) = 6x + 12 > 0, \forall -1 \leq x \leq 2$

Hence, $f(x)$ is increasing in $[-1, 2]$.

Again, function is an algebraic polynomial, therefore it is continuous at $x \in (-1, 2)$ and $(2, 3)$.

For continuity at $x = 2$,

$$\begin{aligned} \lim_{x \rightarrow 2^-} f(x) &= \lim_{x \rightarrow 2^-} (3x^2 + 12x - 1) \\ &= \lim_{h \rightarrow 0} [3(2-h)^2 + 12(2-h) - 1] \\ &= \lim_{h \rightarrow 0} [3(4 + h^2 - 4h) + 24 - 12h - 1] \\ &= \lim_{h \rightarrow 0} (12 + 3h^2 - 12h + 24 - 12h - 1) \\ &= \lim_{h \rightarrow 0} (3h^2 - 24h + 35) = 35 \end{aligned}$$

and $\lim_{x \rightarrow 2^+} f(x) = \lim_{x \rightarrow 2^+} (37 - x)$
 $= \lim_{h \rightarrow 0} [37 - (2 + h)] = 35$

and $f(2) = 3 \cdot 2^2 + 12 \cdot 2 - 1$
 $= 12 + 24 - 1 = 35$

Therefore, $LHL = RHL = f(2) \Rightarrow$ function is continuous at $x = 2 \Rightarrow$ function is continuous in $-1 \leq x \leq 3$.

Now, $Rf'(2) = \lim_{x \rightarrow 2^+} \frac{f(x) - f(2)}{x - 2}$
 $= \lim_{h \rightarrow 0} \frac{f(2+h) - f(2)}{h}$
 $= \lim_{h \rightarrow 0} \frac{37 - (2+h) - (3 \times 2^2 + 12 \times 2 - 1)}{h}$
 $= \lim_{h \rightarrow 0} \frac{-h}{h} = -1$
 and $Lf'(2) = \lim_{x \rightarrow 2^-} \frac{f(x) - f(2)}{x - 2} = \lim_{h \rightarrow 0} \frac{f(2-h) - f(2)}{-h}$
 $= \lim_{h \rightarrow 0} \frac{[3(2-h)^2 + 12(2-h) - 1] - [3 \times 2^2 + 12 \times 2 - 1]}{-h}$
 $= \lim_{h \rightarrow 0} \frac{[12 + 3h^2 - 12h + 24 - 12h - 1] - 35}{-h}$
 $= \lim_{h \rightarrow 0} \frac{3h^2 - 24h + 35 - 35}{-h}$
 $= \lim_{h \rightarrow 0} \frac{3h - 24}{-1} = 24$

Since, $Rf'(2) \neq Lf'(2)$, $f'(2)$ does not exist.
 Again, $f(x)$ is an increasing in $[-1, 2]$ and is decreasing in $(2, 3)$, it shows that $f(x)$ has a maximum value at $x = 2$.
 Therefore, options (a), (b), (c), (d) are all correct.

41. Here, $y^2 = 16x, 0 \leq y \leq 6$

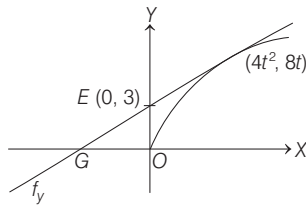

Tangent at F, $yt = x + at^2$
 At $x = 0, y = at = 4t$
 Also, $(4t^2, 8t)$ satisfy $y = mx + c$.
 $\Rightarrow 8t = 4mt^2 + 3$
 $\Rightarrow 4mt^2 - 8t + 3 = 0$
 $\therefore \text{Area of } \Delta = \frac{1}{2} \begin{vmatrix} 0 & 3 & 1 \\ 0 & 4t & 1 \\ 4t^2 & 8t & 1 \end{vmatrix} = \frac{1}{2} \cdot 4t^2(3 - 4t)$
 $A = 2[3t^2 - 4t^3]$
 $\therefore \frac{dA}{dt} = 2[6t - 12t^2] = -12t(2t - 1)$
 $\frac{-}{0} \quad \frac{+}{\frac{1}{2}} \quad \frac{-}{}$

\therefore Maximum at $t = \frac{1}{2}$ and $4mt^2 - 8t + 3 = 0$
 $\Rightarrow m - 4 + 3 = 0$
 $\Rightarrow m = 1$
 $G(0, 4t) \Rightarrow G(0, 2)$

$\Rightarrow y_1 = 2$
 $(x_0, y_0) = (4t^2, 8t) = (1, 4)$
 $y_0 = 4$
 $\therefore \text{Area} = 2\left(\frac{3}{4} - \frac{1}{2}\right) = \frac{1}{2}$

42. $f(x) = \frac{(x^2 + ax + 1) - 2ax}{x^2 + ax + 1} = 1 - \frac{2ax}{x^2 + ax + 1}$
 $f'(x) = -\left[\frac{(x^2 + ax + 1) \cdot 2a - 2ax(2x + a)}{(x^2 + ax + a)^2} \right]$
 $= \left[\frac{-2ax^2 + 2a}{(x^2 + ax + a)^2} \right] = 2a \left[\frac{(x^2 - 1)}{(x^2 + ax + 1)^2} \right] \dots(i)$
 $f''(x) = 2a \left[\frac{(x^2 + ax + 1)^2(2x) - 2(x^2 - 1)(2x + a)}{(x^2 + ax + 1)^4} \right]$
 $= 2a \left[\frac{2x(x^2 + ax + 1) - 2(x^2 - 1)(2x + a)}{(x^2 + ax + 1)^3} \right] \dots(ii)$

Now, $f''(1) = \frac{4a(a+2)}{(a+2)^3} = \frac{4a}{(a+2)^2}$
 and $f''(-1) = \frac{4a(a-2)}{(2-a)^3} = \frac{-4a}{(a-2)^2}$
 $\therefore (2+a)^2 f''(1) + (2-a)^2 f''(-1) = 4a - 4a = 0$

43. When $x \in (-1, 1)$,
 $x^2 < 1 \Rightarrow x^2 - 1 < 0$
 $\therefore f'(x) < 0, f(x)$ is decreasing.
 Also, at $x = 1, f''(1) = \frac{4a}{(a+2)^2} > 0 \quad [\because 0 < a < 2]$

So, $f(x)$ has local minimum at $x = 1$.

44. $g'(x) = \frac{f'(e^x)}{1 + (e^x)^2} \cdot e^x$
 $= 2a \left[\frac{e^{2x} - 1}{(e^{2x} + ae^x + 1)^2} \right] \left(\frac{e^x}{1 + e^{2x}} \right)$
 $g'(x) = 0, \text{ if } e^{2x} - 1 = 0, \text{ i.e. } x = 0$
 If $x < 0, e^{2x} < 1 \Rightarrow g'(x) < 0$

45. Let $g(x) = \frac{d}{dx} [f(x) \cdot f'(x)]$
 To get the zero of $g(x)$, we take function
 $h(x) = f(x) \cdot f'(x)$
 between any two roots of $h(x)$, there lies atleast one root of $h'(x) = 0$.
 $\Rightarrow g(x) = 0 \Rightarrow h(x) = 0$
 $\Rightarrow f(x) = 0 \text{ or } f'(x) = 0$
 If $f(x) = 0$ has 4 minimum solutions.
 $f'(x) = 0$ has 3 minimum solutions.
 $h(x) = 0$ has 7 minimum solutions.
 $\Rightarrow h'(x) = g(x) = 0$ has 6 minimum solutions.

268 Application of Derivatives

46. To maximise area of ΔAPB , we know that, $OP = 10$ and $\sin \theta = r/10$, where $\theta \in (0, \pi/2)$... (i)

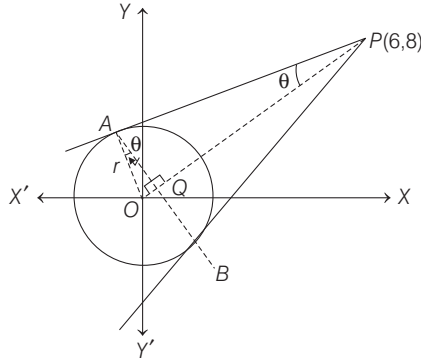

$$\begin{aligned} \therefore \text{Area} &= \frac{1}{2}(2AQ)(PQ) \\ &= AQ \cdot PQ = (r \cos \theta)(10 - OQ) \\ &= (r \cos \theta)(10 - r \sin \theta) \\ &= 10 \sin \theta \cos \theta (10 - 10 \sin^2 \theta) \quad [\text{from Eq. (i)}] \end{aligned}$$

$$\begin{aligned} \Rightarrow A &= 100 \cos^3 \theta \sin \theta \\ \Rightarrow \frac{dA}{d\theta} &= 100 \cos^4 \theta - 300 \cos^2 \theta \cdot \sin^2 \theta \end{aligned}$$

$$\text{Put } \frac{dA}{d\theta} = 0$$

$$\Rightarrow \cos^2 \theta = 3 \sin^2 \theta$$

$$\Rightarrow \tan \theta = 1/\sqrt{3}$$

$$\Rightarrow \theta = \pi/6$$

At which $\frac{dA}{d\theta} < 0$, thus when $\theta = \pi/6$, area is maximum

$$\text{From Eq. (i), } r = 10 \sin \frac{\pi}{6} = 5 \text{ units}$$

47. Let us take a point $P(\sqrt{6} \cos \theta, \sqrt{3} \sin \theta)$ on $\frac{x^2}{6} + \frac{y^2}{3} = 1$.

Now, to minimise the distance from P to given straight line $x + y = 7$, shortest distance exists along the common normal.

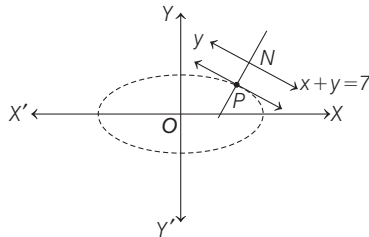

$$\text{Slope of normal at } P = \frac{a^2/x_1}{b^2/y_1} = \frac{\sqrt{6} \sec \theta}{\sqrt{6} \operatorname{cosec} \theta} = \sqrt{2} \tan \theta = 1$$

$$\text{So, } \cos \theta = \sqrt{\frac{2}{3}}$$

$$\text{and } \sin \theta = \frac{1}{\sqrt{3}}$$

Hence, required point is $P(2, 1)$.

$$48. \text{ Given, } f'(x) = \begin{vmatrix} 2ax & 2ax-1 & 2ax+b+1 \\ b & b+1 & -1 \\ 2(ax+b) & 2ax+2b+1 & 2ax+b \end{vmatrix}$$

Applying $R_3 \rightarrow R_3 - R_1 - 2R_2$, we get

$$f'(x) = \begin{vmatrix} 2ax & 2ax-1 & 2ax+b+1 \\ b & b+1 & -1 \\ 0 & 0 & 1 \end{vmatrix}$$

$$\Rightarrow f'(x) = 2ax + b$$

On integrating both sides, we get

$$f(x) = ax^2 + bx + c$$

Since, maximum at $x = 5/2 \Rightarrow f'(5/2) = 0$

$$\Rightarrow 5a + b = 0 \quad \dots(i)$$

$$\text{Also, } f(0) = 2 \Rightarrow c = 2 \quad \dots(ii)$$

$$\text{and } f(1) = 1 \Rightarrow a + b + c = 1 \quad \dots(iii)$$

On solving Eqs. (i), (ii) and (iii), we get

$$a = \frac{1}{4}, b = -\frac{5}{4}, c = 2$$

$$\text{Thus, } f(x) = \frac{1}{4}x^2 - \frac{5}{4}x + 2$$

49. Let coordinates of P be $(t, t^2 + 1)$

Reflection of P in $y = x$ is $P_1(t^2 + 1, t)$

which clearly lies on $y^2 = x - 1$

Similarly, let coordinates of Q be $(s^2 + 1, s)$

Its reflection in $y = x$ is

$Q_1(s, s^2 + 1)$, which lies on $x^2 = y - 1$.

We have, $PQ_1^2 = (t-s)^2 + (t^2 - s^2)^2 = P_1Q^2$

$$\Rightarrow PQ_1 = P_1Q$$

Also $PP_1 \parallel QQ_1$ [\because both perpendicular to $y = x$]

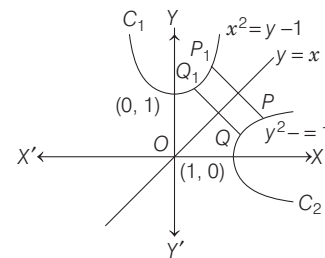

Thus, PP_1QQ_1 is an isosceles trapezium.

Also, P lies on PQ_1 and Q lies on P_1Q , then

$$PQ \geq \min \{PP_1, QQ_1\}$$

Let us take $\min \{PP_1, QQ_1\} = PP_1$

$$\begin{aligned} \therefore PQ^2 &\geq PP_1^2 = (t^2 + 1 - t)^2 + (t^2 + 1 - t)^2 \\ &= 2(t^2 + 1 - t)^2 = f(t) \end{aligned} \quad [\text{say}]$$

we have, $f'(t) = 4(t^2 + 1 - t)(2t - 1)$

$$= 4[(t - 1/2)^2 + 3/4][2t - 1]$$

Now, $f'(t) = 0$

$$\Rightarrow t = 1/2$$

Also, $f'(t) < 0$ for $t < 1/2$

and $f'(t) > 0$ for $t > 1/2$

Thus, $f(t)$ is least when $t = 1/2$.

Corresponding to $t = 1/2$, point P_0 on C_1 is $(1/2, 5/4)$ and P_1 (which we take as Q_0) on C_2 are $(5/4, 1/2)$. Note that $P_0Q_0 \leq PQ$ for all pairs of (P, Q) with P on C_2 .

50. Let the square S is to be bounded by the lines $x = \pm 1/2$ and $y = \pm 1/2$.

We have,
$$a^2 = \left(x_1 - \frac{1}{2}\right)^2 + \left(\frac{1}{2} - y_1\right)^2$$

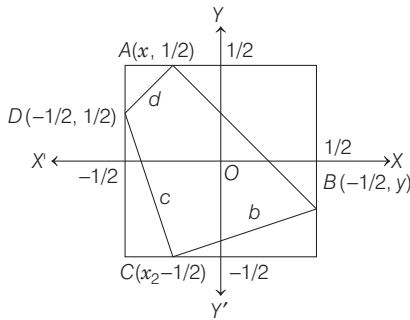

$$= x_1^2 - y_1^2 - x_1 - y_1 + \frac{1}{2}$$

Similarly,
$$b^2 = x_2^2 - y_1^2 - x_2 + y_1 + \frac{1}{2}$$

$$c^2 = x_2^2 - y_2^2 + x_2 + y_2 + \frac{1}{2}$$

$$d^2 = x_1^2 - y_2^2 + x_1 - y_2 + \frac{1}{2}$$

$$\therefore a^2 + b^2 + c^2 + d^2 = 2(x_1^2 + y_1^2 + x_2^2 + y_2^2) + 2$$

Therefore, $0 \leq x_1^2, x_2^2, y_1^2, y_2^2 \leq \frac{1}{4}$

$$0 \leq x_1^2 + x_2^2 + y_1^2 + y_2^2 \leq 1$$

$$\Rightarrow 0 \leq 2(x_1^2 + x_2^2 + y_1^2 + y_2^2) \leq 2$$

But $2 \leq 2(x_1^2 + x_2^2 + y_1^2 + y_2^2) + 2 \leq 4$

Alternate Solution

$$c^2 = x_2^2 + y_2^2 \quad \dots (i)$$

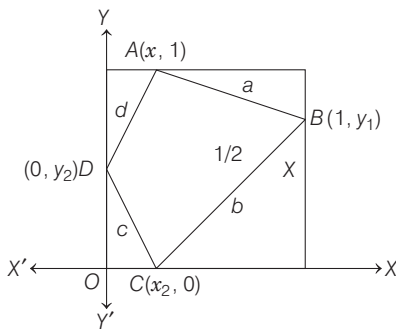

$$b^2 = (1 - x_2)^2 + y_1^2 \quad \dots (ii)$$

$$a^2 = (1 - y_1)^2 + (1 - x_1)^2 \quad \dots (iii)$$

$$d^2 = x_1^2 + (1 - y_2)^2 \quad \dots (iv)$$

On adding Eqs. (i), (ii), (iii) and (iv), we get

$$a^2 + b^2 + c^2 + d^2 = \{x_1^2 + (1 - x_1)^2\} + \{y_1^2 + (1 - y_1)^2\} + \{x_2^2 + (1 - x_2)^2\} + \{y_2^2 + (1 - y_2)^2\}$$

where x_1, y_1, x_2, y_2 all vary in the interval $[0, 1]$.

Now, consider the function $y = x^2 + (1 - x)^2, 0 \leq x \leq 1$ differentiating $\Rightarrow \frac{dy}{dx} = 2x - 2(1 - x)$. For maximum or

minimum $\frac{dy}{dx} = 0$.

$$\Rightarrow 2x - 2(1 - x) = 0 \Rightarrow 2x - 2 + 2x = 0$$

$$\Rightarrow 4x = 2 \Rightarrow x = 1/2$$

Again,
$$\frac{d^2y}{dx^2} = 2 + 2 = 4$$

Hence, y is minimum at $x = \frac{1}{2}$ and its minimum value is $1/4$. Clearly, value is maximum when $x = 1$.

$$\therefore \text{Minimum value of } a^2 + b^2 + c^2 + d^2 = \frac{1}{2} + \frac{1}{2} + \frac{1}{2} + \frac{1}{2} = 2$$

and maximum value is $1 + 1 + 1 + 1 = 4$

51. $f(x)$ is a differentiable function for $x > 0$.

Therefore, for maxima or minima, $f'(x) = 0$ must satisfy.

Given,
$$f(x) = \frac{1}{8} \ln x - bx + x^2, x > 0$$

$$\Rightarrow f'(x) = \frac{1}{8} \cdot \frac{1}{x} - b + 2x$$

For $f'(x) = 0$

$$\Rightarrow \frac{1}{8x} - b + 2x = 0$$

$$\Rightarrow 16x^2 - 8bx + 1 = 0$$

$$\Rightarrow (4x - b)^2 = b^2 - 1 \quad \dots (i)$$

$$\Rightarrow (4x - b)^2 = (b - 1)(b + 1) \quad [b \geq 0, \text{ given}]$$

Case I $0 \leq b < 1$, has no solution. Since, RHS is negative in this domain and LHS is positive.

Case II When $b = 1$, then $x = \frac{1}{4}$ is the only solution. When $b = 1$,

$$f'(x) = \frac{1}{8x} - 1 + 2x$$

$$= \frac{2}{x} \left(x^2 - \frac{1}{2}x + \frac{1}{16} \right) = \frac{2}{x} \left(x - \frac{1}{4} \right)^2$$

We have to check the sign of $f'(x)$ at $x = 1/4$.

Interval	Sign of $f'(x)$	Nature of $f(x)$
$-\infty, 0$	-ve	↓
$\left(0, \frac{1}{4}\right)$	+ve	↑
$\left(\frac{1}{4}, \infty\right)$	+ve	↑

From sign chart, it is clear that $f'(x)$ has no change of sign in left and right of $x = 1/4$.

270 Application of Derivatives

Case III When $b > 1$, then

$$\begin{aligned} f'(x) &= \frac{1}{8x} - b + 2x = \frac{2}{x} \left(x^2 - \frac{1}{2}bx + \frac{1}{16} \right) \\ &= \frac{2}{x} \left[\left(x - \frac{b}{4} \right)^2 - \frac{1}{16}(b^2 - 1) \right] \\ &= \frac{2}{x} \left[\left(x - \frac{b}{4} - \frac{1}{4}\sqrt{b^2 - 1} \right) \left(x - \frac{b}{4} + \frac{1}{4}\sqrt{b^2 - 1} \right) \right] \\ &= \frac{2}{x} (x - \alpha)(x - \beta) \end{aligned}$$

where, $\alpha < \beta$ and $\alpha = \frac{1}{4}(b - \sqrt{b^2 - 1})$ and $\beta = \frac{1}{4}(b + \sqrt{b^2 - 1})$. From sign scheme, it is clear that

$$f'(x) \begin{cases} > 0, & \text{for } 0 < x < \alpha \\ < 0, & \text{for } \alpha < x < \beta \\ > 0, & \text{for } x > \beta \end{cases}$$

By the first derivative test, $f(x)$ has a maxima at $x = \alpha = \frac{1}{4}(b - \sqrt{b^2 - 1})$

and $f(x)$ has a minima at $x = \beta = \frac{1}{4}(b + \sqrt{b^2 - 1})$

52. Let equation of any line through the point (h, k) is

$$y - k = m(x - h) \quad \dots (i)$$

For this line to intersect the positive direction of two axes, $m = \tan \theta < 0$, since the angle in anti-clockwise direction from X -axis becomes obtuse.

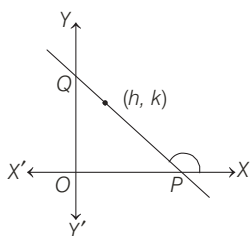

The line (i) meets X -axis at $P\left(h - \frac{k}{m}, 0\right)$ and Y -axis at $Q(0, k - mh)$.

$$\begin{aligned} \text{Let } A &= \text{area of } \triangle OPQ = \frac{1}{2} OP \cdot OQ \\ &= \frac{1}{2} \left(h - \frac{k}{m} \right) (k - mh) \\ &= \frac{1}{2} \left(\frac{mh - k}{m} \right) (k - mh) \\ &= -\frac{1}{2m} (k - mh)^2 \\ &= -\frac{1}{2 \tan \theta} (k - h \tan \theta)^2 \quad [\because m = \tan \theta] \\ &= -\frac{1}{2 \tan \theta} (k^2 + h^2 \tan^2 \theta - 2hk \tan \theta) \\ &= \frac{1}{2} (2kh - k^2 \cot \theta - h^2 \tan \theta) \end{aligned}$$

$$\begin{aligned} \Rightarrow \frac{dA}{d\theta} &= \frac{1}{2} [-k^2(-\operatorname{cosec}^2 \theta) - h^2 \sec^2 \theta] \\ &= \frac{1}{2} [k^2 \operatorname{cosec}^2 \theta - h^2 \sec^2 \theta] \end{aligned}$$

To obtain minimum value of A , $\frac{dA}{d\theta} = 0$

$$\begin{aligned} \Rightarrow k^2 \operatorname{cosec}^2 \theta - h^2 \sec^2 \theta &= 0 \\ \Rightarrow \frac{k^2}{\sin^2 \theta} &= \frac{h^2}{\cos^2 \theta} \Rightarrow \frac{k^2}{h^2} = \tan^2 \theta \\ \Rightarrow \tan \theta &= \pm \frac{k}{h} \end{aligned}$$

$\therefore \tan \theta < 0, k > 0, h > 0$ [given]

Therefore, $\tan \theta = -\frac{k}{h}$ (only possible value).

$$\begin{aligned} \text{Now, } \frac{d^2A}{d\theta^2} &= \frac{1}{2} [-2k^2 \operatorname{cosec}^2 \theta \cot \theta - 2h^2 \sec^2 \theta \tan \theta] \\ &= -[k^2(1 + \cot^2 \theta) \cot \theta + h^2(1 + \tan^2 \theta) \tan \theta] \\ \Rightarrow \left[\frac{d^2A}{d\theta^2} \right]_{\tan \theta = -k/h} &= -\left[k^2 \left(1 + \frac{h^2}{k^2} \right) \left(\frac{-h}{k} \right) \right. \\ &\quad \left. + h^2 \left(1 + \frac{k^2}{h^2} \right) \left(\frac{-k}{h} \right) \right] \\ &= \left[k^2 \left(\frac{k^2 + h^2}{k^2} \right) \left(\frac{h}{k} \right) + h^2 \left(\frac{h^2 + k^2}{h^2} \right) \left(\frac{k}{h} \right) \right] \\ &= \left[\frac{(k^2 + h^2)h}{k} + \frac{(h^2 + k^2)k}{h} \right] \\ &= (k^2 + h^2) \left[\frac{h}{k} + \frac{k}{h} \right] > 0 \quad [\because h, k > 0] \end{aligned}$$

Therefore, A is least when $\tan \theta = -k/h$. Also, the least value of A is

$$\begin{aligned} A &= \frac{1}{2} \left[2hk - k^2 \left(\frac{-h}{k} \right) - h^2 \left(\frac{-k}{h} \right) \right] \\ &= \frac{1}{2} [2hk + kh + kh] = 2hk \end{aligned}$$

53. Since $x^2 + y^2 = 1$ a circle S_1 has centre $(0, 0)$ and cuts X -axis at $P(-1, 0)$ and $Q(1, 0)$. Now, suppose the circle S_2 , with centre at $Q(1, 0)$ has radius r . Since, the circle has to meet the first circle, $0 < r < 2$.

Again, equation of the circle with centre at $Q(1, 0)$ and radius r is

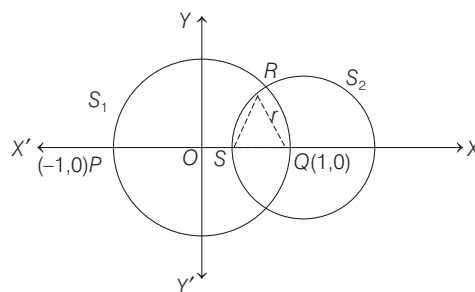

$$(x - 1)^2 + y^2 = r^2 \quad \dots (i)$$

To find the coordinates of point R , we have to solve it with

$$x^2 + y^2 = 1 \quad \dots \text{(ii)}$$

On subtracting Eq. (ii) from Eq. (i), we get

$$\begin{aligned} (x-1)^2 - x^2 &= r^2 - 1 \\ \Rightarrow x^2 + 1 - 2x - x^2 &= r^2 - 1 \\ \Rightarrow 1 - 2x &= r^2 - 1 \\ \therefore x &= \frac{2-r^2}{2} \end{aligned}$$

On putting the value of x in Eq. (i), we get

$$\begin{aligned} \left(\frac{2-r^2}{2}\right)^2 + y^2 &= 1 \\ \Rightarrow y^2 &= 1 - \left(\frac{2-r^2}{2}\right)^2 = 1 - \frac{(2-r^2)^2}{4} \\ &= 1 - \frac{r^4 - 4r^2 + 4}{4} \\ &= \frac{4 - r^4 + 4r^2 - 4}{4} \\ &= \frac{4r^2 - r^4}{4} \\ &= \frac{r^2(4-r^2)}{4} \\ \Rightarrow y &= \frac{r\sqrt{4-r^2}}{2} \end{aligned}$$

Again, we know that, coordinates of S are $(1-r, 0)$, therefore

$$SQ = 1 - (1-r) = r$$

Let A denotes the area of ΔQSR , then

$$\begin{aligned} A &= \frac{1}{2} r \left[r \frac{\sqrt{4-r^2}}{2} \right] \\ &= \frac{1}{4} r^2 \sqrt{4-r^2} \\ \Rightarrow A^2 &= \frac{1}{16} r^4 (4-r^2) \end{aligned}$$

$$\begin{aligned} \text{Let } f(r) &= r^4(4-r^2) = 4r^4 - r^6 \\ \Rightarrow f'(r) &= 16r^3 - 6r^5 = 2r^3(8-3r^2) \end{aligned}$$

For maxima and minima, put $f'(r) = 0$

$$\begin{aligned} \Rightarrow 2r^3(8-3r^2) &= 0 \\ \Rightarrow r &= 0, 8-3r^2 = 0 \\ \Rightarrow r &= 0, 3r^2 = 8 \\ \Rightarrow r &= 0, r^2 = 8/3 \\ \Rightarrow r &= 0, r = \frac{2\sqrt{2}}{\sqrt{3}} \end{aligned}$$

$$[\because 0 < r < 2, \text{ so } r = 2\sqrt{2}/\sqrt{3}]$$

$$\text{Again, } f''(r) = 48r^2 - 30r^4$$

$$\begin{aligned} \Rightarrow f''\left(\frac{2\sqrt{2}}{\sqrt{3}}\right) &= 48\left(\frac{4 \times 2}{3}\right) - 30\left(\frac{4 \times 2}{3}\right)^2 \\ &= 16 \times 8 - \frac{10 \times 64}{3} = 128 - \frac{640}{3} = -\frac{256}{2} < 0 \end{aligned}$$

Therefore, $f(r)$ is maximum when, $r = \frac{2\sqrt{2}}{\sqrt{3}}$

Hence, maximum value of A

$$\begin{aligned} &= \frac{1}{4} \left(\frac{2\sqrt{2}}{\sqrt{3}}\right)^2 \sqrt{4 - \left(\frac{2\sqrt{2}}{\sqrt{3}}\right)^2} = \frac{1}{4} \left(\frac{8}{3}\right) \cdot \sqrt{4 - \frac{8}{3}} \\ &= \frac{2}{3} \cdot \frac{\sqrt{12-8}}{\sqrt{3}} = \frac{2 \cdot 2}{3\sqrt{3}} = \frac{4}{3\sqrt{3}} = \frac{4\sqrt{3}}{9} \end{aligned}$$

$$54. \text{ Given, } f(x) = \begin{cases} -x^3 + \frac{(b^3 - b^2 + b - 1)}{(b^2 + 3b + 2)}, & \text{if } 0 \leq x \leq 1 \\ \frac{b^3 - b^2 + b - 1}{2x - 3}, & \text{if } 1 \leq x \leq 3 \end{cases}$$

is smallest at $x = 1$.

So, $f(x)$ is decreasing on $[0, 1]$ and increasing on $[1, 3]$.

Here, $f(1) = -1$ is the smallest value at $x = 1$.

\therefore Its smallest value occur as

$$\lim_{x \rightarrow 1^-} f(x) = \lim_{x \rightarrow 1^-} (-x^3) + \frac{(b^3 - b^2 + b - 1)}{b^2 + 3b + 2}$$

In order this value is not less than -1 , we must have

$$\frac{b^3 - b^2 + b - 1}{b^2 + 3b + 2} \geq -1 \Rightarrow \frac{(b^2 + 1)(b - 1)}{(b + 1)(b + 2)} \geq 0$$



$$\therefore b \in (-2, -1) \cup [1, \infty)$$

55.

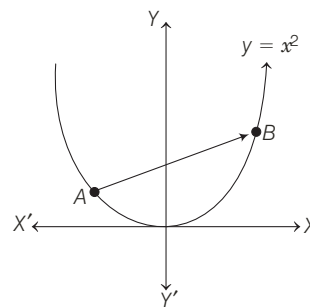

Any point on the parabola $y = x^2$ is of the form (t, t^2) .

$$\text{Now, } \frac{dy}{dx} = 2x \Rightarrow \left[\frac{dy}{dx}\right]_{x=t} = 2t$$

Which is the slope of the tangent. So, the slope of the normal to $y = x^2$ at $A(t, t^2)$ is $-1/2t$.

Therefore, the equation of the normal to

$$y = x^2 \text{ at } A(t, t^2) \text{ is}$$

$$y - t^2 = \left(-\frac{1}{2t}\right)(x - t) \quad \dots \text{(i)}$$

Suppose Eq. (i) meets the curve again at $B(t_1, t_1^2)$.

272 Application of Derivatives

Then, $t_1^2 - t^2 = -\frac{1}{2t}(t_1 - t)$

$\Rightarrow (t_1 - t)(t_1 + t) = -\frac{1}{2t}(t_1 - t)$

$\Rightarrow (t_1 + t) = -\frac{1}{2t}$

$\Rightarrow t_1 = -t - \frac{1}{2t}$

Therefore, length of chord,

$$\begin{aligned} L = AB^2 &= (t - t_1)^2 + (t^2 - t_1^2)^2 \\ &= (t - t_1)^2 + (t - t_1)^2(t + t_1)^2 \\ &= (t - t_1)^2[1 + (t + t_1)^2] \\ &= \left(t + t + \frac{1}{2t}\right)^2 \left[1 + \left(t - t - \frac{1}{2t}\right)^2\right] \end{aligned}$$

$\Rightarrow L = \left(2t + \frac{1}{2t}\right)^2 \left(1 + \frac{1}{4t^2}\right) = 4t^2 \left(1 + \frac{1}{4t^2}\right)^3$

On differentiating w.r.t. t , we get

$$\begin{aligned} \frac{dL}{dt} &= 8t \left(1 + \frac{1}{4t^2}\right)^3 + 12t^2 \left(1 + \frac{1}{4t^2}\right)^2 \left(-\frac{2}{4t^3}\right) \\ &= 2 \left(1 + \frac{1}{4t^2}\right)^2 \left[4t \left(1 + \frac{1}{4t^2}\right) - \frac{3}{t}\right] \\ &= 2 \left(1 + \frac{1}{4t^2}\right)^2 \left(4t - \frac{2}{t}\right) = 4 \left(1 + \frac{1}{4t^2}\right)^2 \left(2t - \frac{1}{t}\right) \end{aligned}$$

For maxima or minima, we must have $\frac{dL}{dt} = 0$

$\Rightarrow 2t - \frac{1}{t} = 0 \Rightarrow t^2 = \frac{1}{2}$

$\Rightarrow t = \pm \frac{1}{\sqrt{2}}$

Now, $\frac{d^2L}{dt^2} = 8 \left(1 + \frac{1}{4t^2}\right) \left(-\frac{1}{2t^3}\right) \left(2t - \frac{1}{t}\right) + 4 \left(1 + \frac{1}{4t^2}\right)^2 \left(2 + \frac{1}{t^2}\right)$

$\Rightarrow \left[\frac{d^2L}{dt^2}\right]_{t=\pm 1/\sqrt{2}} = 0 + 4 \left(1 + \frac{1}{2}\right)^2 (2+2) > 0$

Therefore, L is minimum, when $t = \pm 1/\sqrt{2}$. For $t = 1/\sqrt{2}$, point A is $(1/\sqrt{2}, 1/2)$ and point B is $(-\sqrt{2}, 2)$. When $t = -1/\sqrt{2}$, A is $(-1/\sqrt{2}, 1/2)$, B is $(\sqrt{2}, 2)$.

Again, when $t = 1/\sqrt{2}$, the equation of AB is

$$\frac{y-2}{\frac{1}{2}-2} = \frac{x+\sqrt{2}}{\frac{1}{\sqrt{2}}+\sqrt{2}}$$

$\Rightarrow (y-2) \left\{ \left(\frac{1}{\sqrt{2}} + \sqrt{2}\right) \right\} = (x + \sqrt{2}) \left(\frac{1}{2} - 2\right)$

$\Rightarrow -2y + 4 = \sqrt{2}x + 2$

$\Rightarrow \sqrt{2}x + 2y - 2 = 0$

and when $t = -1/\sqrt{2}$, the equation of AB is

$$\frac{y-2}{\frac{1}{2}-2} = \frac{x-\sqrt{2}}{-\left(\frac{1}{\sqrt{2}}\right)-\sqrt{2}}$$

$\Rightarrow (y-2) \left(-\frac{1}{\sqrt{2}} - \sqrt{2}\right) = (x - \sqrt{2}) \left(\frac{1}{2} - 2\right)$

$\Rightarrow 2y - 4 = \sqrt{2}(x - \sqrt{2})$

$\Rightarrow \sqrt{2}x - 2y + 2 = 0$

- 56.** Let $2b$ be the diameter of the circular portion and a be the lengths of the other sides of the rectangle.

Total perimeter = $2a + 4b + \pi b = K$ [say] ... (i)

Now, let the light transmission rate (per square metre) of the coloured glass be L and Q be the total amount of transmitted light.

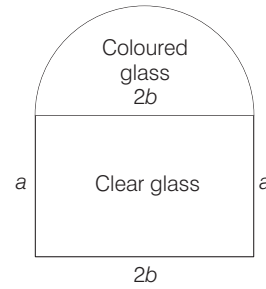

Then, $Q = 2ab(3L) + \frac{1}{2}\pi b^2(L)$

$\Rightarrow Q = \frac{L}{2}(\pi b^2 + 12ab)$

$\Rightarrow Q = \frac{L}{2}[\pi b^2 + 6b(K - 4b - \pi b)]$ [from Eq. (i)]

$\Rightarrow Q = \frac{L}{2}(6Kb - 24b^2 - 5\pi b^2)$

On differentiating w.r.t. b , we get

$$\frac{dQ}{db} = \frac{L}{2}(6K - 48b - 10\pi b)$$

For maximum, put $\frac{dQ}{db} = 0$

$\Rightarrow b = \frac{6K}{48 + 10\pi}$... (ii)

Now, $\frac{d^2Q}{db^2} = \frac{L}{2}(-48 - 10\pi) < 0$

Thus, Q is maximum and from Eqs. (i) and (ii), we get $(48 + 10\pi)b = 6\{2a + 4b + \pi b\}$

\therefore Ratio = $\frac{2b}{a} = \frac{6}{6 + \pi} = 6:6 + \pi$

- 57.** Since, the chord QR is parallel to the tangent at P .

$\therefore ON \perp QR$

Consequently, N is the mid-point of chord QR .

$\therefore QR = 2QN = 2r \sin \theta$

Also, $ON = r \cos \theta$

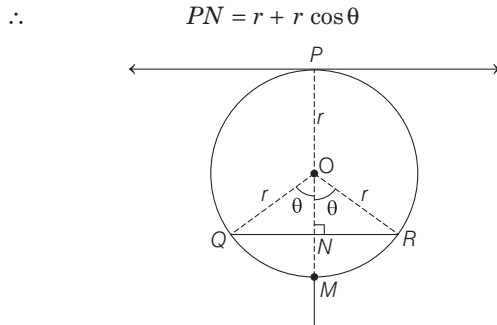

Let A denotes the area of ΔPQR .
 Then, $A = \frac{1}{2} \cdot 2r \sin \theta (r + r \cos \theta)$
 $\Rightarrow A = r^2 (\sin \theta + \sin \theta \cos \theta)$
 $\Rightarrow A = r^2 (\sin \theta + \frac{1}{2} \sin 2\theta)$
 $\Rightarrow \frac{dA}{d\theta} = r^2 (\cos \theta + \cos 2\theta)$
 and $\frac{d^2A}{d\theta^2} = r^2 (-\sin \theta - 2 \sin 2\theta)$

For maximum and minimum values of θ , we put $\frac{dA}{d\theta} = 0$
 $\Rightarrow \cos \theta + \cos 2\theta = 0 \Rightarrow \cos 2\theta = -\cos \theta$
 $\Rightarrow \cos \theta = \cos (\pi - 2\theta) \Rightarrow \theta = \frac{\pi}{3}$

Clearly, $\frac{d^2A}{d\theta^2} < 0$ for $\theta = \frac{\pi}{3}$
 Hence, the area of ΔPQR is maximum when $\theta = \frac{\pi}{3}$.

The maximum area of ΔPQR is given by
 $A = r^2 \left(\sin \frac{\pi}{3} + \frac{1}{2} \sin \frac{2\pi}{3} \right) = r^2 \left(\frac{\sqrt{3}}{2} + \frac{\sqrt{3}}{4} \right)$
 $= \frac{3\sqrt{3}}{4} r^2$ sq units

58. Let $P(a \cos \theta, 2 \sin \theta)$ be a point on the ellipse

$$4x^2 + a^2y^2 = 4a^2, \text{ i.e. } \frac{x^2}{a^2} + \frac{y^2}{4} = 1$$

Let $A(0, -2)$ be the given point.

Then,
 $(AP)^2 = a^2 \cos^2 \theta + 4(1 + \sin \theta)^2$
 $\Rightarrow \frac{d}{d\theta} (AP)^2 = -a^2 \sin 2\theta + 8(1 + \sin \theta) \cdot \cos \theta$
 $\Rightarrow \frac{d}{d\theta} (AP)^2 = [(8 - 2a^2) \sin \theta + 8] \cos \theta$

For maximum or minimum, we put $\frac{d}{d\theta} (AP)^2 = 0$

$\Rightarrow [(8 - 2a^2) \sin \theta + 8] \cos \theta = 0$
 $\Rightarrow \cos \theta = 0$ or $\sin \theta = \frac{4}{a^2 - 4}$

$[\because 4 < a^2 < 8 \Rightarrow \frac{4}{a^2 - 4} > 1 \Rightarrow \sin \theta > 1, \text{ which is impossible}]$

Now, $\frac{d^2}{d\theta^2} (AP)^2 = -\{(8 - 2a^2) \sin \theta + 8\} \sin \theta + (8 - 2a^2) \cdot \cos^2 \theta$

For $\theta = \frac{\pi}{2}$, we have $\frac{d^2}{d\theta^2} (AP)^2 = -(16 - 2a^2) < 0$

Thus, AP^2 i.e. AP is maximum when $\theta = \frac{\pi}{2}$. The point on the curve $4x^2 + a^2y^2 = 4a^2$ that is farthest from the point $A(0, -2)$ is $\left(a \cos \frac{\pi}{2}, 2 \sin \frac{\pi}{2} \right) = (0, 2)$

59. Let $AF = x$ and $AE = y$, ΔABC and ΔEDC are similar.

$\therefore \frac{AB}{ED} = \frac{AC}{CE}$

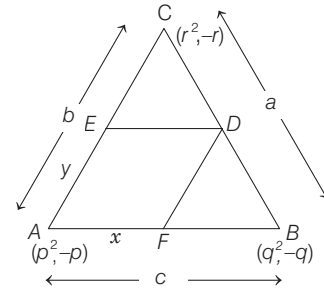

$\Rightarrow \frac{c}{x} = \frac{b}{b-y}$
 $\Rightarrow bx = c(b-y)$
 $\Rightarrow x = \frac{c}{b}(b-y)$

Let z denotes the area of parallelogram $AFDE$.

Then, $z = xy \sin A$
 $\Rightarrow z = \frac{c}{b}(b-y)y \cdot \sin A \dots(i)$

On differentiating w.r.t. y we get

$$\frac{dz}{dy} = \frac{c}{b}(b-2y) \sin A$$

and $\frac{d^2z}{dy^2} = \frac{-2c}{b} \sin A$

For maximum or minimum values of z , we must have

$\frac{dz}{dy} = 0$

$\Rightarrow \frac{c}{b}(b-2y) = 0$

$\Rightarrow y = \frac{b}{2}$

Clearly, $\frac{d^2z}{dy^2} = \frac{-2c}{b} < 0, \forall y$

Hence, z is maximum, when $y = \frac{b}{2}$.

On putting $y = \frac{b}{2}$ in Eq. (i), we get

274 Application of Derivatives

the maximum value of z is

$$\begin{aligned} z &= \frac{c}{b} \left(b - \frac{b}{2} \right) \cdot \frac{b}{2} \cdot \sin A = \frac{1}{4} bc \sin A \\ &= \frac{1}{2} \text{ area of } \triangle ABC \\ &= \frac{1}{2} \times \frac{1}{2} \begin{vmatrix} p^2 & -p & 1 \\ q^2 & q & 1 \\ r^2 & -r & 1 \end{vmatrix} \end{aligned}$$

Applying $R_3 \rightarrow R_3 - R_1$ and $R_2 \rightarrow R_2 - R_1$

$$\begin{aligned} &= \frac{1}{4} \begin{vmatrix} p^2 & -p & 1 \\ q^2 - p^2 & q + p & 0 \\ r^2 - p^2 & -r + p & 0 \end{vmatrix} \\ &= \frac{1}{4} (p+q)(r-p) \begin{vmatrix} p^2 & -p & 1 \\ q-p & 1 & 0 \\ r+p & -1 & 0 \end{vmatrix} \\ &= \frac{1}{4} (p+q)(r-p)(-q-r) \\ &= \frac{1}{4} (p+q)(q+r)(p-r) \end{aligned}$$

60. Let $y = f(x) = \sin^3 x + \lambda \sin^2 x$, $-\frac{\pi}{2} < x < \frac{\pi}{2}$

Let $\sin x = t$
 $\therefore y = t^3 + \lambda t^2, -1 < t < 1$
 $\Rightarrow \frac{dy}{dt} = 3t^2 + 2t\lambda = t(3t + 2\lambda)$

For exactly one minima and exactly one maxima dy/dt must have two distinct roots $\in (-1, 1)$.

$$\begin{aligned} \Rightarrow t = 0 \text{ and } t = -\frac{2\lambda}{3} \in (-1, 1) \\ \Rightarrow -1 < -\frac{2\lambda}{3} < 1 \\ \Rightarrow -\frac{3}{2} < \lambda < \frac{3}{2} \\ \Rightarrow \lambda \in \left(-\frac{3}{2}, \frac{3}{2} \right) \end{aligned}$$

61. Given,

$$\begin{aligned} y &= \frac{x}{1+x^2} \\ \Rightarrow \frac{dy}{dx} &= \frac{(1+x^2) \cdot 1 - x(2x)}{(1+x^2)^2} = \frac{1-x^2}{(1+x^2)^2} \\ \text{Let } \frac{dy}{dx} &= g(x) \quad [\text{i.e. slope of tangent}] \\ \therefore g(x) &= \frac{1-x^2}{(1+x^2)^2} \\ \Rightarrow g'(x) &= \frac{(1+x^2)^2 \cdot (-2x) - (1-x^2) \cdot 2(1+x^2) \cdot 2x}{(1+x^2)^4} \\ &= \frac{-2x(1+x^2)[(1+x^2)+2(1-x^2)]}{(1+x^2)^4} = \frac{-2x(3-x^2)}{(1+x^2)^3} \end{aligned}$$

For greatest or least values of m , we should have

$$g'(x) = 0 \Rightarrow x = 0, x = \pm \sqrt{3}$$

Now,

$$g''(x) = \frac{(1+x^2)^3(6x^2-6) - (2x^3-6x) \cdot 3(1+x^2)^2 \cdot 2x}{(1+x^2)^6}$$

At $x = 0$, $g''(x) = -6 < 0$

$\therefore g'(x)$ has a maximum value at $x = 0$.

$\Rightarrow (x = 0, y = 0)$ is the required point at which tangent to the curve has the greatest slope.

62. Let the house of the swimmer be at B .

$$\therefore AB = L \text{ km}$$

Let the swimmer land at C on the shore and let

$$AC = x \text{ km}$$

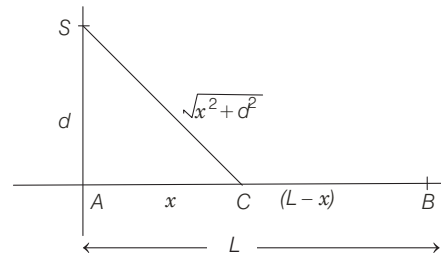

$$\therefore SC = \sqrt{x^2 + d^2} \text{ and } CB = (L - x)$$

$$\therefore \text{Time} = \frac{\text{Distance}}{\text{Speed}}$$

Time from S to B = Time from S to C + Time from C to B

$$\therefore T = \frac{\sqrt{x^2 + d^2}}{u} + \frac{L - x}{v}$$

$$\text{Let } f(x) = T = \frac{1}{u} \sqrt{x^2 + d^2} + \frac{L - x}{v}$$

$$\Rightarrow f'(x) = \frac{1}{u} \cdot \frac{1 \cdot 2x}{2\sqrt{x^2 + d^2}} + 0 - \frac{1}{v}$$

For maximum or minimum, put $f'(x) = 0$

$$\Rightarrow v^2 x^2 = u^2 (x^2 + d^2)$$

$$\Rightarrow x^2 = \frac{u^2 d^2}{v^2 - u^2}$$

$$\therefore f'(x) = 0 \text{ at } x = \pm \frac{ud}{\sqrt{v^2 - u^2}}, (v > u)$$

$$\text{But } x \neq \frac{-ud}{\sqrt{v^2 - u^2}}$$

$$\therefore \text{We consider, } x = \frac{ud}{\sqrt{v^2 - u^2}}$$

$$\text{Now, } f''(x) = \frac{1}{u} \frac{d^2}{\sqrt{x^2 + d^2}(x^2 + d^2)} > 0, \forall x$$

$$\text{Hence, } f \text{ has minimum at } x = \frac{ud}{\sqrt{v^2 - u^2}}$$

63. Given, $ax^2 + \frac{b}{x} \geq c, \forall x > 0; a, b > 0$

Let $f(x) = ax^2 + \frac{b}{x} - c$

$\therefore f'(x) = 2ax - \frac{b}{x^2} = \frac{2ax^3 - b}{x^2}$

$\Rightarrow f''(x) = 2a + \frac{2b}{x^3} > 0$ [since, a, b are all positive]

Now, put $f'(x) = 0 \Rightarrow x = \left(\frac{b}{2a}\right)^{1/3} > 0$ [$\because a, b > 0$]

At $x = \left(\frac{b}{2a}\right)^{1/3}, f''(x) = +ve$

$\Rightarrow f(x)$ has minimum at $x = \left(\frac{b}{2a}\right)^{1/3}$.

and $f\left(\left(\frac{b}{2a}\right)^{1/3}\right) = a\left(\frac{b}{2a}\right)^{2/3} + \frac{b}{(b/2a)^{1/3}} - c \geq 0$

$= \left(\frac{2a}{b}\right)^{1/3} \cdot \frac{3b}{2} - c \geq 0$

$\Rightarrow \left(\frac{2a}{b}\right)^{1/3} \cdot \frac{3b}{2} \geq c$

On cubing both sides, we get

$\frac{2a}{b} \cdot \frac{27b^3}{8} \geq c^3$

$\Rightarrow 27ab^2 \geq 4c^3$

64. Let $f(x) = x + y$, where $xy = 1$

$\Rightarrow f(x) = x + \frac{1}{x}$

$\Rightarrow f'(x) = 1 - \frac{1}{x^2} = \frac{x^2 - 1}{x^2}$

Also, $f''(x) = 2/x^3$

On putting $f'(x) = 0$, we get

$x = \pm 1$, but $x > 0$ [neglecting $x = -1$]

$f''(x) > 0$, for $x = 1$

Hence, $f(x)$ attains minimum at $x = 1, y = 1$

$\Rightarrow (x + y)$ has minimum value 2.

65. The given function $f : R \rightarrow R$ be defined by

$$\begin{aligned} f(\theta) &= (\sin \theta + \cos \theta)^2 + (\sin \theta - \cos \theta)^4 \\ &= 1 + \sin 2\theta + (1 - \sin 2\theta)^2 \\ &= 1 + \sin 2\theta + 1 + \sin^2 2\theta - 2\sin 2\theta \\ &= \sin^2 2\theta - \sin 2\theta + 2 \\ &= \left(\sin 2\theta - \frac{1}{2}\right)^2 + \frac{7}{4} \end{aligned}$$

The local minimum of function 'f' occurs when

$\sin 2\theta = \frac{1}{2}$

$\Rightarrow 2\theta = \frac{\pi}{6}, \frac{5\pi}{6}, \frac{13\pi}{6}, \dots$

$\Rightarrow \theta = \frac{\pi}{12}, \frac{5\pi}{12}, \frac{13\pi}{12}, \dots$

but $\theta \in \{\lambda_1\pi, \lambda_2\pi, \dots, \lambda_r\pi\}$, where $0 < \lambda_1 < \dots < \lambda_r < 1$.

$\therefore \theta = \frac{\pi}{12}, \frac{5\pi}{12}$

So, $\lambda_1 + \dots + \lambda_r = \frac{1}{12} + \frac{5}{12} = 0.50$

66. Given set S of polynomials with real coefficients

$S = \{(x^2 - 1)^2(a_0 + a_1x + a_2x^2 + a_3x^3) : a_0, a_1, a_2, a_3 \in R\}$

and for a polynomial $f \in S$, Let

$f(x) = (x^2 - 1)^2(a_0 + a_1x + a_2x^2 + a_3x^3)$

it have -1 and 1 as repeated roots twice, so graph of $f(x)$ touches the X -axis at $x = -1$ and $x = 1$, so $f'(x)$ having at least three roots $x = -1, 1$ and α . Where $\alpha \in (-1, 1)$ and $f''(x)$ having at least two roots in interval $(-1, 1)$

So, $m_{f'} = 3$ and $m_{f''} = 2$

\therefore Minimum possible value of $(m_{f'} + m_{f''}) = 5$

67. On drawing the diagram of given situation

$MD^2 + MC^2 = 64 + x^2 + 121 + (10 - x)^2$

$= f(x)$

[say]

$\Rightarrow f(x) = 2x^2 - 20x + 285$

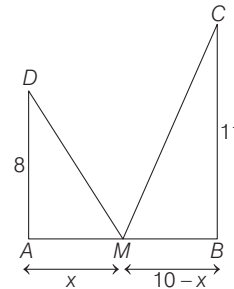

For minima, $f'(x) = 0 \Rightarrow 4x - 20 = 0 \Rightarrow x = 5$

As $f''(x) = 4 > 0$

$\therefore AM = 5$ m

68. Here, volume of cylindrical container, $V = \pi r^2 h$... (i)

and let volume of the material used be T .

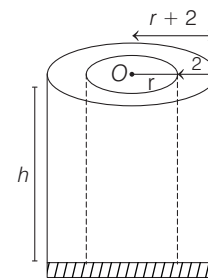

$\therefore T = \pi [(r + 2)^2 - r^2] h + \pi (r + 2)^2 \times 2$

$\Rightarrow T = \pi [(r + 2)^2 - r^2] \cdot \frac{V}{\pi r^2} + 2\pi (r + 2)^2$

[$\because V = \pi r^2 h \Rightarrow h = \frac{V}{\pi r^2}$]

276 Application of Derivatives

$$\Rightarrow T = V \left(\frac{r+2}{r} \right)^2 + 2\pi (r+2)^2 - V$$

On differentiating w.r.t. r , we get

$$\frac{dT}{dr} = 2V \cdot \left(\frac{r+2}{r} \right) \cdot \left(\frac{-2}{r^2} \right) + 4\pi (r+2)$$

$$\text{At } r=10, \frac{dT}{dr} = 0$$

$$\text{Now, } 0 = (r+2) \cdot 4 \left(\pi - \frac{V}{r^3} \right)$$

$$\Rightarrow \frac{V}{r^3} = \pi$$

$$\text{where } r = 10$$

$$\Rightarrow \frac{V}{1000} = \pi$$

$$\text{or } \frac{V}{250\pi} = 4$$

- 69. PLAN** As to maximise or minimise area of triangle, we should find area in terms of parametric coordinates and use second derivative test.

Here, tangent at $P(2 \cos \theta, \sqrt{3} \sin \theta)$ is

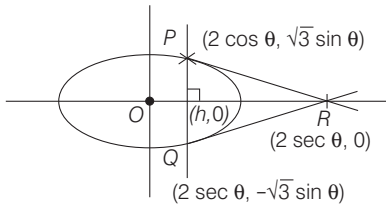

$$\frac{x}{2} \cos \theta + \frac{y}{\sqrt{3}} \sin \theta = 1$$

$$\therefore R(2 \sec \theta, 0)$$

$$\Rightarrow \Delta = \text{Area of } \triangle PQR$$

$$\begin{aligned} &= \frac{1}{2} (2\sqrt{3} \sin \theta) (2 \sec \theta - 2 \cos \theta) \\ &= 2\sqrt{3} \cdot \sin^3 \theta / \cos \theta \quad \dots(i) \end{aligned}$$

$$\text{Since, } \frac{1}{2} \leq h \leq 1$$

$$\therefore \frac{1}{2} \leq 2 \cos \theta \leq 1$$

$$\Rightarrow \frac{1}{4} \leq \cos \theta \leq \frac{1}{2} \quad \dots(ii)$$

$$\therefore \frac{d\Delta}{d\theta} = \frac{2\sqrt{3} \{ \cos \theta \cdot 3 \sin^2 \theta \cos \theta - \sin^3 \theta (-\sin \theta) \}}{\cos^2 \theta}$$

$$= \frac{2\sqrt{3} \cdot \sin^2 \theta}{\cos^2 \theta} [3 \cos^2 \theta + \sin^2 \theta]$$

$$= \frac{2\sqrt{3} \sin^2 \theta}{\cos^2 \theta} \cdot [2 \cos^2 \theta + 1]$$

$$= 2\sqrt{3} \tan^2 \theta (2 \cos^2 \theta + 1) > 0$$

$$\text{When } \frac{1}{4} \leq \cos \theta \leq \frac{1}{2},$$

$$\therefore \Delta_1 = \Delta_{\max} \text{ occurs at } \cos \theta = \frac{1}{4} = \left(\frac{2\sqrt{3} \cdot \sin^3 \theta}{\cos \theta} \right)$$

$$\text{When } \cos \theta = \frac{1}{4} = \frac{45\sqrt{5}}{8}$$

$$\Delta_2 = \Delta_{\min} \text{ occurs at } \cos \theta = \frac{1}{2}$$

$$= \left(\frac{2\sqrt{3} \sin^3 \theta}{\cos \theta} \right)$$

$$\text{When } \cos \theta = \frac{1}{2} = \frac{9}{2}$$

$$\therefore \frac{8}{\sqrt{5}} \Delta_1 - 8\Delta_2 = 45 - 36 = 9$$

70. PLAN

- Local maximum and local minimum are those points at which $f'(x)=0$, when defined for all real numbers.
- Local maximum and local minimum for piecewise functions are also been checked at sharp edges.

Description of Situation $y = |x| = \begin{cases} x, & \text{if } x \geq 0 \\ -x, & \text{if } x < 0 \end{cases}$

$$\text{Also, } y = |x^2 - 1| = \begin{cases} (x^2 - 1), & \text{if } x \leq -1 \text{ or } x \geq 1 \\ (1 - x^2), & \text{if } -1 \leq x \leq 1 \end{cases}$$

$$\begin{aligned} y = |x| + |x^2 - 1| &= \begin{cases} -x + 1 - x^2, & \text{if } x \leq -1 \\ -x + 1 - x^2, & \text{if } -1 \leq x \leq 0 \\ x + 1 - x^2, & \text{if } 0 \leq x \leq 1 \\ x + x^2 - 1, & \text{if } x \geq 1 \end{cases} \\ &= \begin{cases} -x^2 - x + 1, & \text{if } x \leq -1 \\ -x^2 - x + 1, & \text{if } -1 \leq x \leq 0 \\ -x^2 + x + 1, & \text{if } 0 \leq x \leq 1 \\ x^2 + x - 1, & \text{if } x \geq 1 \end{cases} \end{aligned}$$

which could be graphically shown as

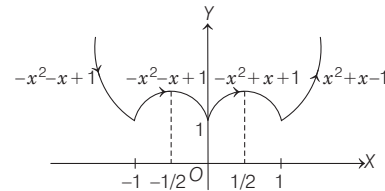

Thus, $f(x)$ attains maximum at $x = \frac{1}{2}, \frac{-1}{2}$ and $f(x)$

attains minimum at $x = -1, 0, 1$.

\Rightarrow Total number of points = 5

- 71. PLAN** If $f(x)$ is least degree polynomial having local maximum and local minimum at α and β .

$$\text{Then, } f'(x) = \lambda (x - \alpha)(x - \beta)$$

$$\text{Here, } p'(x) = \lambda (x - 1)(x - 3) = \lambda (x^2 - 4x + 3)$$

On integrating both sides between 1 to 3, we get

$$\int_1^3 p'(x) dx = \int_1^3 \lambda (x^2 - 4x + 3) dx$$

$$\Rightarrow (p(x))_1^3 = \lambda \left(\frac{x^3}{3} - 2x^2 + 3x \right)_1^3$$

$$\Rightarrow p(3) - p(1) = \lambda \left((9 - 18 + 9) - \left(\frac{1}{3} - 2 + 3 \right) \right)$$

$$\Rightarrow 2 - 6 = \lambda \left\{ \frac{-4}{3} \right\}$$

$$\Rightarrow \lambda = 3$$

$$\Rightarrow p'(x) = 3(x-1)(x-3)$$

$$\therefore p'(0) = 9$$

72. $f(x) = x^4 - 4x^3 + 12x^2 + x - 1$

$$f'(x) = 4x^3 - 12x^2 + 24x + 1$$

$$f''(x) = 12x^2 - 24x + 24 = 12(x^2 - 2x + 2)$$

$$= 12\{(x-1)^2 + 1\} > 0 \forall x$$

$\Rightarrow f'(x)$ is increasing.

Since, $f'(x)$ is cubic and increasing.

$\Rightarrow f'(x)$ has only one real root and two imaginary roots.

$\therefore f(x)$ cannot have all distinct roots.

\Rightarrow Atmost 2 real roots.

Now, $f(-1) = 15$, $f(0) = -1$, $f(1) = 9$

$\therefore f(x)$ must have one root in $(-1, 0)$ and other in $(0, 1)$.

\Rightarrow 2 real roots.

73. Let $g(x) = e^{f(x)}$, $\forall x \in R$

$$\Rightarrow g'(x) = e^{f(x)} \cdot f'(x)$$

$\Rightarrow f'(x)$ changes its sign from positive to negative in the neighbourhood of $x = 2009$

$\Rightarrow f(x)$ has local maxima at $x = 2009$.

So, the number of local maximum is one.

74. Let $f(\theta) = \frac{1}{\sin^2 \theta + 3 \sin \theta \cos \theta + 5 \cos^2 \theta}$

Again let, $g(\theta) = \sin^2 \theta + 3 \sin \theta \cos \theta + 5 \cos^2 \theta$
 $= \frac{1 - \cos 2\theta}{2} + 5 \left(\frac{1 + \cos 2\theta}{2} \right) + \frac{3}{2} \sin 2\theta$
 $= 3 + 2 \cos 2\theta + \frac{3}{2} \sin 2\theta$

$$\therefore g(\theta)_{\min} = 3 - \sqrt{4 + \frac{9}{4}}$$

$$= 3 - \frac{5}{2} = \frac{1}{2}$$

\therefore Maximum value of $f(\theta) = \frac{1}{1/2} = 2$

75. Given, $A = \{x | x^2 + 20 \leq 9x\} = \{x | x \in [4, 5]\}$

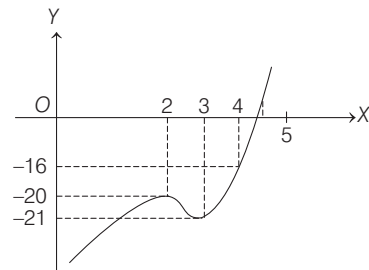

Now, $f'(x) = 6(x^2 - 5x + 6)$

Put $f'(x) = 0 \Rightarrow x = 2, 3$

$$f(2) = -20, f(3) = -21, f(4) = -16, f(5) = -7$$

From graph, maximum value of $f(x)$ on set A is $f(5) = -7$.

11

Indefinite Integration

Topic 1 Some Standard Results

Objective Questions I (Only one correct option)

1. If $\int \frac{\cos \theta}{5 + 7 \sin \theta - 2 \cos^2 \theta} d\theta = A \log_e |B(\theta)| + C$, where C is a constant of integration, then $\frac{B(\theta)}{A}$ can be

- (a) $\frac{2 \sin \theta + 1}{\sin \theta + 3}$ (b) $\frac{2 \sin \theta + 1}{5(\sin \theta + 3)}$
(c) $\frac{5(\sin \theta + 3)}{2 \sin \theta + 1}$ (d) $\frac{5(2 \sin \theta + 1)}{\sin \theta + 3}$

(2020 Main, 5 Sep II)

2. Let $f(x) = \int \frac{\sqrt{x}}{(1+x)^2} dx$ ($x \geq 0$). Then $f(3) - f(1)$ is equal to

- (a) $-\frac{\pi}{6} + \frac{1}{2} + \frac{\sqrt{3}}{4}$ (b) $-\frac{\pi}{12} + \frac{1}{2} + \frac{\sqrt{3}}{4}$
(c) $\frac{\pi}{6} + \frac{1}{2} - \frac{\sqrt{3}}{4}$ (d) $\frac{\pi}{12} + \frac{1}{2} - \frac{\sqrt{3}}{4}$

(2020 Main, 4 Sep I)

3. If $\int \frac{d\theta}{\cos^2 \theta (\tan 2\theta + \sec 2\theta)} = \lambda \tan \theta + 2 \log_e |f(\theta)| + C$

where C is a constant of integration, then the ordered pair $(\lambda, f(\theta))$ is equal to

(2020 Main, 9 Jan II)

- (a) $(1, 1 + \tan \theta)$ (b) $(1, 1 - \tan \theta)$
(c) $(-1, 1 + \tan \theta)$ (d) $(-1, 1 - \tan \theta)$

4. Let $\alpha \in (0, \pi/2)$ be fixed. If the integral

$$\int \frac{\tan x + \tan \alpha}{\tan x - \tan \alpha} dx = A(x) \cos 2\alpha + B(x)$$

$\sin 2\alpha + C$, where C is a constant of integration, then the functions $A(x)$ and $B(x)$ are respectively

(2019 Main, 12 April II)

- (a) $x + \alpha$ and $\log_e |\sin(x + \alpha)|$ (b) $x - \alpha$ and $\log_e |\sin(x - \alpha)|$
(c) $x - \alpha$ and $\log_e |\cos(x - \alpha)|$ (d) $x + \alpha$ and $\log_e |\sin(x - \alpha)|$

5. The integral $\int \frac{2x^3 - 1}{x^4 + x} dx$ is equal to

(here C is a constant of integration) (2019 Main, 12 April I)

- (a) $\frac{1}{2} \log_e \frac{|x^3 + 1|}{x^2} + C$ (b) $\frac{1}{2} \log_e \frac{(x^3 + 1)^2}{|x^3|} + C$
(c) $\log_e \left| \frac{x^3 + 1}{x} \right| + C$ (d) $\log_e \frac{|x^3 + 1|}{x^2} + C$

6. If $\int \frac{dx}{(x^2 - 2x + 10)^2} = A \left(\tan^{-1} \left(\frac{x-1}{3} \right) + \frac{f(x)}{x^2 - 2x + 10} \right) + C$, where C is a constant of integration, then

(2019 Main, 10 April I)

- (a) $A = \frac{1}{27}$ and $f(x) = 9(x-1)$
(b) $A = \frac{1}{81}$ and $f(x) = 3(x-1)$
(c) $A = \frac{1}{54}$ and $f(x) = 3(x-1)$
(d) $A = \frac{1}{54}$ and $f(x) = 9(x-1)^2$

7. If $\int \frac{dx}{x^3(1+x^6)^{2/3}} = xf(x)(1+x^6)^{1/3} + C$

where C is a constant of integration, then the function $f(x)$ is equal to

(2019 Main, 8 April I)

- (a) $-\frac{1}{6x^3}$ (b) $-\frac{1}{2x^3}$
(c) $-\frac{1}{2x^2}$ (d) $\frac{3}{x^2}$

8. $\int \frac{\sin \frac{5x}{2}}{\sin \frac{x}{2}} dx$ is equal to

(where C is a constant of integration)

(2019 Main, 8 April I)

- (a) $2x + \sin x + 2 \sin 2x + C$
(b) $x + 2 \sin x + 2 \sin 2x + C$
(c) $x + 2 \sin x + \sin 2x + C$
(d) $2x + \sin x + \sin 2x + C$

9. The integral $\int \frac{3x^{13} + 2x^{11}}{(2x^4 + 3x^2 + 1)^4} dx$ is equal to (where C

is a constant of integration)

(2019 Main, 12 Jan II)

- (a) $\frac{x^4}{6(2x^4 + 3x^2 + 1)^3} + C$ (b) $\frac{x^{12}}{6(2x^4 + 3x^2 + 1)^3} + C$
(c) $\frac{x^4}{(2x^4 + 3x^2 + 1)^3} + C$ (d) $\frac{x^{12}}{(2x^4 + 3x^2 + 1)^3} + C$

10. If $\int \frac{x+1}{\sqrt{2x-1}} dx = f(x)\sqrt{2x-1} + C$, where C is a constant of integration, then $f(x)$ is equal to (2019 Main, 11 Jan II)

- (a) $\frac{2}{3}(x+2)$ (b) $\frac{1}{3}(x+4)$
 (c) $\frac{2}{3}(x-4)$ (d) $\frac{1}{3}(x+1)$

11. If $\int \frac{\sqrt{1-x^2}}{x^4} dx = A(x)(\sqrt{1-x^2})^m + C$,

for a suitable chosen integer m and a function $A(x)$, where C is a constant of integration, then $(A(x))^m$ equals (2019 Main, 11 Jan I)

- (a) $\frac{1}{9x^4}$ (b) $\frac{-1}{3x^3}$
 (c) $\frac{-1}{27x^9}$ (d) $\frac{1}{27x^6}$

12. Let $n \geq 2$ be a natural number and $0 < \theta < \frac{\pi}{2}$. Then,

$\int \frac{(\sin^n \theta - \sin \theta)^{\frac{1}{n}} \cos \theta}{\sin^{n+1} \theta} d\theta$ is equal to

(where C is a constant of integration) (2019 Main, 10 Jan I)

- (a) $\frac{n}{n^2-1} \left(1 - \frac{1}{\sin^{n+1} \theta}\right)^{\frac{n+1}{n}} + C$
 (b) $\frac{n}{n^2-1} \left(1 + \frac{1}{\sin^{n-1} \theta}\right)^{\frac{n+1}{n}} + C$
 (c) $\frac{n}{n^2-1} \left(1 - \frac{1}{\sin^{n-1} \theta}\right)^{\frac{n+1}{n}} + C$
 (d) $\frac{n}{n^2+1} \left(1 - \frac{1}{\sin^{n-1} \theta}\right)^{\frac{n+1}{n}} + C$

13. If $f(x) = \int \frac{5x^8 + 7x^6}{(x^2 + 1 + 2x^7)^2} dx$, ($x \geq 0$), and $f(0) = 0$, then the value of $f(1)$ is (2019 Main, 9 Jan I)

- (a) $-\frac{1}{2}$ (b) $-\frac{1}{4}$
 (c) $\frac{1}{4}$ (d) $\frac{1}{2}$

14. For $x^2 \neq n\pi + 1$, $n \in N$ (the set of natural numbers), the integral

$\int x \sqrt{\frac{2 \sin(x^2 - 1) - \sin 2(x^2 - 1)}{2 \sin(x^2 - 1) + \sin 2(x^2 - 1)}} dx$ is equal to

(where C is a constant of integration) (2019 Main, 9 Jan I)

- (a) $\frac{1}{2} \log_e |\sec(x^2 - 1)| + C$
 (b) $\log_e \left| \sec \left(\frac{x^2 - 1}{2} \right) \right| + C$
 (c) $\log_e \left| \frac{1}{2} \sec^2(x^2 - 1) \right| + C$
 (d) $\frac{1}{2} \log_e \left| \sec^2 \left(\frac{x^2 - 1}{2} \right) \right| + C$

15. The integral

$$\int \frac{\sin^2 x \cos^2 x}{(\sin^5 x + \cos^3 x \sin^2 x + \sin^3 x \cos^2 x + \cos^5 x)^2} dx$$

is equal to (2018 Main)

- (a) $\frac{1}{3(1 + \tan^3 x)} + C$ (b) $\frac{-1}{3(1 + \tan^3 x)} + C$
 (c) $\frac{1}{1 + \cot^3 x} + C$ (d) $\frac{-1}{1 + \cot^3 x} + C$

(where C is a constant of integration)

16. The value of $\int \frac{dx}{x^2(x^4 + 1)^{3/4}}$ is (2015 Main)

- (a) $\left(\frac{x^4 + 1}{x^4}\right)^{\frac{1}{4}} + c$ (b) $(x^4 + 1)^{\frac{1}{4}} + c$
 (c) $-(x^4 + 1)^{\frac{1}{4}} + c$ (d) $-\left(\frac{x^4 + 1}{x^4}\right)^{\frac{1}{4}} + c$

17. $\int \frac{\sec^2 x}{(\sec x + \tan x)^{9/2}} dx$ equals to

(for some arbitrary constant K) (2012)

- (a) $\frac{-1}{(\sec x + \tan x)^{11/2}} \left\{ \frac{1}{11} - \frac{1}{7} (\sec x + \tan x)^2 \right\} + K$
 (b) $\frac{1}{(\sec x + \tan x)^{11/2}} \left\{ \frac{1}{11} - \frac{1}{7} (\sec x + \tan x)^2 \right\} + K$
 (c) $\frac{-1}{(\sec x + \tan x)^{11/2}} \left\{ \frac{1}{11} + \frac{1}{7} (\sec x + \tan x)^2 \right\} + K$
 (d) $\frac{1}{(\sec x + \tan x)^{11/2}} \left\{ \frac{1}{11} + \frac{1}{7} (\sec x + \tan x)^2 \right\} + K$

18. If $I = \int \frac{e^x}{e^{4x} + e^{2x} + 1} dx$, $J = \int \frac{e^{-x}}{e^{-4x} + e^{-2x} + 1} dx$.

Then, for an arbitrary constant c , the value of $J - I$ equals (2008, 3M)

- (a) $\frac{1}{2} \log \left| \frac{e^{4x} - e^{2x} + 1}{e^{4x} + e^{2x} + 1} \right| + c$ (b) $\frac{1}{2} \log \left| \frac{e^{2x} + e^x + 1}{e^{2x} - e^x + 1} \right| + c$
 (c) $\frac{1}{2} \log \left| \frac{e^{2x} - e^x + 1}{e^{2x} + e^x + 1} \right| + c$ (d) $\frac{1}{2} \log \left| \frac{e^{4x} + e^{2x} + 1}{e^{4x} - e^{2x} + 1} \right| + c$

19. If $f(x) = \frac{x}{(1+x^n)^{1/n}}$ for $n \geq 2$ and $g(x) = \underbrace{(fofo\dots of)}_{f \text{ occurs } n \text{ times}}(x)$.

Then, $\int x^{n-2} g(x) dx$ equals (2007, 3M)

- (a) $\frac{1}{n(n-1)} (1 + nx^n)^{1-\frac{1}{n}} + c$ (b) $\frac{1}{n-1} (1 + nx^n)^{1-\frac{1}{n}} + c$
 (c) $\frac{1}{n(n+1)} (1 + nx^n)^{1+\frac{1}{n}} + c$ (d) $\frac{1}{n+1} (1 + nx^n)^{1+\frac{1}{n}} + c$

20. The value of $\int \frac{(x^2 - 1) dx}{x^3 \sqrt{2x^4 - 2x^2 + 1}}$ is (2006, 3M)

- (a) $2 \sqrt{2 - \frac{2}{x^2} + \frac{1}{x^4}} + c$ (b) $2 \sqrt{2 + \frac{2}{x^2} + \frac{1}{x^4}} + c$
 (c) $\frac{1}{2} \sqrt{2 - \frac{2}{x^2} + \frac{1}{x^4}} + c$ (d) None of these

Objective Questions II

(One or more than one correct option)

21. Let $f: R \rightarrow R$ and $g: R \rightarrow R$ be two non-constant differentiable functions. If $f'(x) = (e^{f(x)-g(x)}) g'(x)$ for all $x \in R$ and $f(1) = g(2) = 1$, then which of the following statement(s) is (are) TRUE? (2018 Adv.)
- (a) $f(2) < 1 - \log_e 2$
 - (b) $f(2) > 1 - \log_e 2$
 - (c) $g(1) > 1 - \log_e 2$
 - (d) $g(1) < 1 - \log_e 2$

Integer & Numerical Answer Type Question

22. Let $f: R \rightarrow R$ be a differentiable function with $f(0) = 1$ and satisfying the equation $f(x+y) = f(x)f'(y) + f'(x)f(y)$ for all $x, y \in R$. Then, the value of $\log_e(f(4))$ is (2018 Adv.)

Fill in the Blank

23. If $\int \frac{4e^x + 6e^{-x}}{9e^x - 4e^{-x}} dx = Ax + B \log(9e^{2x} - 4) + C$, then $A = \dots$, $B = \dots$ and $C = \dots$ (1989, 2M)

Topic 2 Some Special Integrals

Objective Question I (Only one correct option)

1. The integral $\int \sec^{23} x \operatorname{cosec}^{4/3} x dx$ is equal to (here C is a constant of integration) (2019 Main, 9 April I)
- (a) $3 \tan^{-1/3} x + C$
 - (b) $-3 \tan^{-1/3} x + C$
 - (c) $-3 \cot^{-1/3} x + C$
 - (d) $-\frac{3}{4} \tan^{-4/3} x + C$
2. Let $I_n = \int \tan^n x dx$ ($n > 1$). If $I_4 + I_6 = a \tan^5 x + bx^5 + C$, where C is a constant of integration, then the ordered pair (a, b) is equal to (2017 Main)
- (a) $(-\frac{1}{5}, 1)$
 - (b) $(\frac{1}{5}, 0)$
 - (c) $(\frac{1}{5}, -1)$
 - (d) $(-\frac{1}{5}, 0)$

Topic 3 Integration by Parts

Objective Questions (Only one correct option)

1. If $\int x^5 e^{-x^2} dx = g(x)e^{-x^2} + C$, where C is a constant of integration, then $g(-1)$ is equal to (2019 Main, 10 April II)
- (a) -1
 - (b) 1
 - (c) $-\frac{1}{2}$
 - (d) $-\frac{5}{2}$

Analytical & Descriptive Questions

24. For any natural number m , evaluate $\int (x^{3m} + x^{2m} + x^m)(2x^{2m} + 3x^m + 6)^{1/m} dx, x > 0$. (2002, 5M)
25. Evaluate $\int \left(\frac{1 - \sqrt{x}}{1 + \sqrt{x}} \right)^{1/2} \cdot \frac{dx}{x}$ (1997C, 3M)
26. Evaluate $\int \frac{1 - \sqrt{x}}{1 + \sqrt{x}} dx$. (1985, 2 1/2 M)
27. Evaluate $\int \frac{dx}{x^2(x^4 + 1)^{3/4}}$. (1984, 2M)
28. Evaluate the following: (1980, 4M)
- (i) $\int \sqrt{1 + \sin\left(\frac{1}{2}x\right)} dx$
 - (ii) $\int \frac{x^2}{\sqrt{1-x}} dx$
29. Integrate $\frac{x^2}{(a+bx)^2}$. (1979, 2M)
30. Integrate $\sin x \cdot \sin 2x \cdot \sin 3x + \sec^2 x \cdot \cos^2 2x + \sin^4 x \cdot \cos^4 x$. (1979, 1M)
31. Integrate the curve $\frac{x}{1+x^4}$. (1978, 1M)
32. Integrate $\frac{1}{1 - \cot x}$ or $\frac{\sin x}{\sin x - \cos x}$. (1978, 2M)

Analytical & Descriptive Questions

3. Find the indefinite integral $\int \left(\frac{1}{\sqrt[3]{x} + \sqrt[4]{x}} + \frac{\ln(1 + \sqrt[6]{x})}{\sqrt[3]{x} + \sqrt{x}} \right) dx$. (1992, 4M)
4. Evaluate $\int (\sqrt{\tan x} + \sqrt{\cot x}) dx$. (1988, 3M)
5. Evaluate $\int \frac{(\cos 2x)^{1/2}}{\sin x} dx$. (1987, 6M)
6. If $f(x)$ is the integral of $\frac{2 \sin x - \sin 2x}{x^3}$, where $x \neq 0$, then find $\lim_{x \rightarrow 0} f'(x)$. (1979, 3M)

2. If $\int e^{\sec x} (\sec x \tan x f(x) + (\sec x \tan x + \sec^2 x)) dx = e^{\sec x} f(x) + C$, then a possible choice of $f(x)$ is (2019 Main, 9 April II)
- (a) $x \sec x + \tan x + \frac{1}{2}$
 - (b) $\sec x + \tan x + \frac{1}{2}$
 - (c) $\sec x + x \tan x - \frac{1}{2}$
 - (d) $\sec x - \tan x - \frac{1}{2}$

3. The integral $\int \cos(\log_e x) dx$ is equal to (where C is a constant of integration) (2019 Main, 12 Jan I)

- (a) $\frac{x}{2} [\cos(\log_e x) + \sin(\log_e x)] + C$
 (b) $x [\cos(\log_e x) + \sin(\log_e x)] + C$
 (c) $x [\cos(\log_e x) - \sin(\log_e x)] + C$
 (d) $\frac{x}{2} [\sin(\log_e x) - \cos(\log_e x)] + C$

4. If $\int x^5 e^{-4x^3} dx = \frac{1}{48} e^{-4x^3} f(x) + C$,

where C is a constant of integration, then $f(x)$ is equal to (2019 Main, 10 Jan II)

- (a) $-4x^3 - 1$ (b) $4x^3 + 1$
 (c) $-2x^3 - 1$ (d) $-2x^3 + 1$

5. $\int \left(1 + x - \frac{1}{x}\right) e^{x + \frac{1}{x}} dx$ is equal to (2014 Main)

- (a) $(x-1) e^{x + \frac{1}{x}} + c$
 (b) $x e^{x + \frac{1}{x}} + c$
 (c) $(x+1) e^{x + \frac{1}{x}} + c$
 (d) $-x e^{x + \frac{1}{x}} + c$

6. If $\int f(x) dx = \psi(x)$, then $\int x^5 f(x^3) dx$ is equal to

- (a) $\frac{1}{3} [x^3 \psi(x^3) - \int x^2 \psi(x^3) dx] + c$ (2013 Main)
 (b) $\frac{1}{3} x^3 \psi(x^3) - 3 \int x^3 \psi(x^3) dx + c$
 (c) $\frac{1}{3} x^3 \psi(x^3) - \int x^2 \psi(x^3) dx + c$
 (d) $\frac{1}{3} [x^3 \psi(x^3) - \int x^3 \psi(x^3) dx] + c$

Analytical & Descriptive Questions

7. Evaluate $\int \sin^{-1} \left(\frac{2x+2}{\sqrt{4x^2+8x+13}} \right) dx$. (2000, 5M)
8. Find the indefinite integral $\int \cos 2\theta \log \left(\frac{\cos \theta + \sin \theta}{\cos \theta - \sin \theta} \right) d\theta$. (1994, 5M)
9. Evaluate $\int \frac{\sin^{-1} \sqrt{x} - \cos^{-1} \sqrt{x}}{\sin^{-1} \sqrt{x} + \cos^{-1} \sqrt{x}} dx$. (1986, 2½ M)
10. Evaluate $\int \frac{(x-1)e^x}{(x+1)^3} dx$. (1983, 2M)
11. Evaluate $\int (e^{\log x} + \sin x) \cos x dx$. (1981, 2M)

Topic 4 Integration, Irrational Function and Partial Fraction

Objective Questions (Only one correct option)

1. The integral $\int \frac{2x^{12} + 5x^9}{(x^5 + x^3 + 1)^3} dx$ is equal to (2016 Main)

- (a) $\frac{-x^5}{(x^5 + x^3 + 1)^2} + C$
 (b) $\frac{x^{10}}{2(x^5 + x^3 + 1)^2} + C$
 (c) $\frac{x^5}{2(x^5 + x^3 + 1)^2} + C$
 (d) $\frac{-x^{10}}{2(x^5 + x^3 + 1)^2} + C$

where, C is an arbitrary constant.

2. The value of $\int \frac{\cos^3 x + \cos^5 x}{\sin^2 x + \sin^4 x} dx$ is (1995, 2M)
- (a) $\sin x - 6 \tan^{-1}(\sin x) + c$
 (b) $\sin x - 2(\sin x)^{-1} + c$
 (c) $\sin x - 2(\sin x)^{-1} - 6 \tan^{-1}(\sin x) + c$
 (d) $\sin x - 2(\sin x)^{-1} + 5 \tan^{-1}(\sin x) + c$

Analytical & Descriptive Questions

3. $\int \frac{x^3 + 3x + 2}{(x^2 + 1)^2 (x + 1)} dx$. (1999, 5M)
4. Evaluate $\int \frac{(x+1)}{x(1+xe^x)^2} dx$. (1996, 2M)

Answers

Topic 1

1. (d) 2. (d) 3. (c) 4. (b)
 5. (c) 6. (c) 7. (b) 8. (c)
 9. (b) 10. (b) 11. (c) 12. (c)
 13. (c) 14. (b) 15. (b) 16. (d)
 17. (c) 18. (c) 19. (a) 20. (c)
 21. (b,c) 22. (2) 23. $A = -\frac{3}{2}$, $B = \frac{35}{36}$ and $C \in R$

24. $\frac{1}{6(m+1)} \cdot (2x^{3m} + 3x^{2m} + 6x^m)^{(m+1)/m} + c$

25. $2[\cos^{-1} \sqrt{x} - \log|1 + \sqrt{1-x}| - \frac{1}{2} \log|x|] + c$

26. $-2\sqrt{1-x} + \cos^{-1} \sqrt{x} + \sqrt{x(1-x)} + c$

27. $-\frac{(x^4 + 1)^{1/4}}{x} + c$

28. (i) $4 \sin \frac{x}{4} - 4 \cos \frac{x}{4} + c$

(ii) $-2 \left\{ \sqrt{1-x} - \frac{2}{3}(1-x)^{3/2} + \frac{1}{5}(1-x)^{5/2} \right\} + c$

29. $\frac{1}{b^3} \left(a + bx - 2a \log(a + bx) - \frac{a^2}{a + bx} + c \right)$

30. $-\frac{\cos 4x}{16} - \frac{\cos 2x}{8} + \frac{\cos 6x}{24} + \sin 2x + \tan x - 2x$
 $+ \frac{3x}{128} - \frac{\sin 4x}{128} + \frac{\sin 8x}{1024}$

31. $\frac{1}{2} \tan^{-1}(x^2) + c$ 32. $\frac{1}{2} \log(\sin x - \cos x) + \frac{x}{2} + c$

Topic 2

1. (b) 2. (b)

3. $\frac{3}{2} x^{2/3} - \frac{12}{7} x^{7/12} + \frac{4}{3} x^{1/2} - \frac{12}{5} x^{5/12} + \frac{1}{2} x^{1/3} - 4x^{1/4} - 7x^{1/6}$
 $- 12x^{1/12} + (2x^{1/2} - 3x^{1/3} + 6x^{1/6} + 11) \ln(1 + x^{1/6})$
 $+ 12 \ln(1 + x^{1/2}) - 3[\ln(1 + x^{1/6})]^2 + c$

4. $\sqrt{2} \tan^{-1} \left(\frac{\sqrt{\tan x} - \sqrt{\cot x}}{\sqrt{2}} \right) + c$

5. $-\log|\cot x + \sqrt{\cot^2 x - 1}| + \frac{1}{\sqrt{2}} \log \left| \frac{\sqrt{2} + \sqrt{1 - \tan^2 x}}{\sqrt{2} - \sqrt{1 - \tan^2 x}} \right| + c$

6. (1)

Topic 3

1. (d) 2. (b) 3. (a) 4. (a)

5. (b) 6. (c)

7. $(x + 1) \tan^{-1} \left(\frac{2x+2}{3} \right) - \frac{3}{4} \log(4x^2 + 8x + 13) + c$

8. $\frac{1}{2} \sin 2\theta \ln \left(\frac{\cos \theta + \sin \theta}{\cos \theta - \sin \theta} \right) + \frac{1}{2} \ln(\cos 2\theta) + c$

9. $\frac{2}{\pi} [\sqrt{x-x^2} - (1-2x) \sin^{-1} \sqrt{x}] - x + c$

10. $\frac{e^x}{(x+1)^2} + c$ 11. $x \sin x + \cos x - \frac{\cos 2x}{4} + c$

Topic 4

1. (b) 2. (c)

3. $-\frac{1}{2} \log|x+1| + \frac{1}{4} \log|x^2+1| + \frac{3}{2} \tan^{-1} x + \frac{x}{x^2+1} + c$

4. $\log \left| \frac{xe^x}{1+xe^x} \right| + \frac{1}{1+xe^x} + c$

Hints & Solutions

Topic 1 Some Standard Results

1. Since, $I = \int \frac{\cos \theta}{5 + 7 \sin \theta - 2 \cos^2 \theta} d\theta$
 $= \int \frac{\cos \theta}{3 + 7 \sin \theta + 2 \sin^2 \theta} d\theta$

Let, $\sin \theta = t \Rightarrow \cos \theta d\theta = dt$

$\therefore I = \int \frac{dt}{2t^2 + 7t + 3} = \frac{1}{2} \int \frac{dt}{t^2 + \frac{7}{2}t + \frac{3}{2}}$

$= \frac{1}{2} \int \frac{dt}{\left(t + \frac{7}{4}\right)^2 + \left(\frac{3}{2} - \frac{49}{16}\right)} = \frac{1}{2} \int \frac{dt}{\left(t + \frac{7}{4}\right)^2 - \left(\frac{5}{4}\right)^2}$

$= \frac{1}{2} \times \frac{1}{2 \times \frac{5}{4}} \log_e \left| \frac{t + \frac{7}{4} - \frac{5}{4}}{t + \frac{7}{4} + \frac{5}{4}} \right| + C'$

$= \frac{1}{5} \log_e \left| \frac{2t+1}{2t+6} \right| + C'$

$= \frac{1}{5} \log_e \left| \frac{2 \sin \theta + 1}{\sin \theta + 3} \right| + C$, where $C = C' - \frac{1}{5} \log_e 2$

$= A \log_e |B(\theta)| + C$ [given]

$\therefore \frac{B(\theta)}{A} = \frac{5(2 \sin \theta + 1)}{(\sin \theta + 3)}$

2. It is given that,

$$f(x) = \int \frac{\sqrt{x}}{(1+x)^2} dx, (x \geq 0)$$

Put $x = \tan^2 t \Rightarrow dx = 2 \tan t \sec^2 t dt$

$$\begin{aligned} \therefore f(x) &= \int \frac{2 \tan^2 t \sec^2 t}{\sec^4 t} dt = \int 2 \sin^2 t dt \\ &= \int (1 - \cos 2t) dt \quad [\because 2 \sin^2 x = 1 - \cos 2x] \\ &= t - \frac{\sin 2t}{2} + C \end{aligned}$$

So, $= t - \frac{\tan t}{1 + \tan^2 t} + C = \tan^{-1} \sqrt{x} - \frac{\sqrt{x}}{1+x} + C$

$$\begin{aligned} \therefore f(3) - f(1) &= \left(\tan^{-1} \sqrt{3} - \frac{\sqrt{3}}{1+3} + C \right) \\ &\quad - \left(\tan^{-1}(1) - \frac{1}{1+1} + C \right) \\ &= \frac{\pi}{3} - \frac{\sqrt{3}}{4} - \frac{\pi}{4} + \frac{1}{2} = \frac{\pi}{12} + \frac{1}{2} - \frac{\sqrt{3}}{4} \end{aligned}$$

Hence, option (d) is correct.

3. Given integral, $I = \int \frac{d\theta}{\cos^2 \theta (\tan 2\theta + \sec 2\theta)}$

$$\begin{aligned} &= \int \frac{\sec^2 \theta \cos 2\theta}{(\sin 2\theta + 1)} d\theta \\ &= \int \frac{\sec^2 \theta (1 - \tan^2 \theta)}{(2 \tan \theta + 1 + \tan^2 \theta)} d\theta \\ &= \int \frac{\sec^2 \theta (1 - \tan \theta)}{1 + \tan \theta} d\theta \end{aligned}$$

Let, $\tan \theta = t$
 $\Rightarrow \sec^2 \theta d\theta = dt$

Then, $I = \int \frac{1-t}{1+t} dt$

$$\begin{aligned} &= \int \left(-1 + \frac{2}{1+t} \right) dt \\ &= -t + 2 \log_e |1+t| + C \\ &= -\tan \theta + 2 \log_e |1 + \tan \theta| + C \\ &= \lambda \tan \theta + 2 \log_e |f(\theta)| + C \text{ (given)} \end{aligned}$$

$\therefore (\lambda, f(\theta)) = (-1, 1 + \tan \theta)$ (on comparing)

Hence, option (c) is correct.

4. Let $I = \int \frac{\tan x + \tan \alpha}{\tan x - \tan \alpha} dx, \alpha \in \left(0, \frac{\pi}{2}\right)$

$$\begin{aligned} &= \int \frac{\frac{\sin x}{\cos x} + \frac{\sin \alpha}{\cos \alpha}}{\frac{\sin x}{\cos x} - \frac{\sin \alpha}{\cos \alpha}} dx \\ &= \int \frac{\sin x \cos \alpha + \sin \alpha \cos x}{\sin x \cos \alpha - \sin \alpha \cos x} dx \\ &= \int \frac{\sin(x+\alpha)}{\sin(x-\alpha)} dx \end{aligned}$$

Now, put $x - \alpha = t \Rightarrow dx = dt$, so

$$\begin{aligned} I &= \int \frac{\sin(t+2\alpha)}{\sin t} dt \\ &= \int \frac{\sin t \cos 2\alpha + \sin 2\alpha \cos t}{\sin t} dt \\ &= \int \left(\cos 2\alpha + \sin 2\alpha \frac{\cos t}{\sin t} \right) dt \\ &= t (\cos 2\alpha) + (\sin 2\alpha) \log_e |\sin t| + C \\ &= (x - \alpha) \cos 2\alpha + (\sin 2\alpha) \log_e |\sin(x - \alpha)| + C \\ &= A(x) \cos 2\alpha + B(x) \sin 2\alpha + C \text{ (given)} \end{aligned}$$

Now on comparing, we get

$$A(x) = x - \alpha \text{ and } B(x) = \log_e |\sin(x - \alpha)|$$

5. **Key Idea**

- (i) Divide each term of numerator and denominator by x^2 .
- (ii) Let $x^2 + \frac{1}{x} = t$

Let integral is $I = \int \frac{2x^3 - 1}{x^4 + x} dx = \int \frac{2x - 1/x^2}{x^2 + \frac{1}{x}} dx$

[dividing each term of numerator and denominator by x^2]

Put $x^2 + \frac{1}{x} = t \Rightarrow \left(2x + \left(-\frac{1}{x^2}\right)\right) dx = dt$

$$\begin{aligned} \therefore I &= \int \frac{dt}{t} = \log_e |t| + C \\ &= \log_e \left| x^2 + \frac{1}{x} \right| + C \\ &= \log_e \left| \frac{x^3 + 1}{x} \right| + C \end{aligned}$$

6. Let $I = \int \frac{dx}{(x^2 - 2x + 10)^2} = \int \frac{dx}{((x-1)^2 + 3^2)^2}$

Now, put $x - 1 = 3 \tan \theta \Rightarrow dx = 3 \sec^2 \theta d\theta$

$$\begin{aligned} \text{So, } I &= \int \frac{3 \sec^2 \theta d\theta}{(3^2 \tan^2 \theta + 3^2)^2} = \int \frac{3 \sec^2 \theta d\theta}{3^4 \sec^4 \theta} \\ &= \frac{1}{27} \int \cos^2 \theta d\theta = \frac{1}{27} \int \frac{1 + \cos 2\theta}{2} d\theta \quad \left[\because \cos^2 \theta = \frac{1 + \cos 2\theta}{2} \right] \\ &= \frac{1}{54} \int (1 + \cos 2\theta) d\theta = \frac{1}{54} \left(\theta + \frac{\sin 2\theta}{2} \right) + C \\ &= \frac{1}{54} \tan^{-1} \left(\frac{x-1}{3} \right) + \frac{1}{108} \left(\frac{2 \tan \theta}{1 + \tan^2 \theta} \right) + C \\ &\quad \left[\because \sin 2\theta = \frac{2 \tan \theta}{1 + \tan^2 \theta} \right] \end{aligned}$$

284 Indefinite Integration

$$\begin{aligned}
 &= \frac{1}{54} \tan^{-1}\left(\frac{x-1}{3}\right) + \frac{1}{54} \frac{\left(\frac{x-1}{3}\right)}{1 + \left(\frac{x-1}{3}\right)^2} + C \\
 &= \frac{1}{54} \tan^{-1}\left(\frac{x-1}{3}\right) + \frac{1}{18} \left(\frac{x-1}{(x-1)^2 + 3^2}\right) + C \\
 &= \frac{1}{54} \tan^{-1}\left(\frac{x-1}{3}\right) + \frac{1}{18} \left(\frac{x-1}{x^2 - 2x + 10}\right) + C \\
 &= \frac{1}{54} \left[\tan^{-1}\left(\frac{x-1}{3}\right) + \frac{3(x-1)}{x^2 - 2x + 10} \right] + C
 \end{aligned}$$

It is given, that

$$I = A \left[\tan^{-1}\left(\frac{x-1}{3}\right) + \frac{f(x)}{x^2 - 2x + 10} \right] + C$$

On comparing, we get $A = \frac{1}{54}$ and $f(x) = 3(x-1)$.

$$\begin{aligned}
 7. \text{ Let } I &= \int \frac{dx}{x^3(1+x^6)^{2/3}} \\
 &= \int \frac{dx}{x^3 \cdot x^4 \left(\frac{1}{x^6} + 1\right)^{2/3}} = \int \frac{dx}{x^7 \left(\frac{1}{x^6} + 1\right)^{2/3}}
 \end{aligned}$$

Now, put $\frac{1}{x^6} + 1 = t^3$

$$\Rightarrow -\frac{6}{x^7} dx = 3t^2 dt \Rightarrow \frac{dx}{x^7} = -\frac{t^2}{2} dt$$

$$\begin{aligned}
 \text{So, } I &= \int -\frac{1}{2} \frac{t^2 dt}{t^2} = -\frac{1}{2} \int dt \\
 &= -\frac{1}{2} t + C = -\frac{1}{2} \left(\frac{1}{x^6} + 1\right)^{1/3} + C \quad \left[\because t^3 = \frac{1}{x^6} + 1 \right] \\
 &= -\frac{1}{2} \frac{1}{x^2} (1+x^6)^{1/3} + C \\
 &= x \cdot f(x) \cdot (1+x^6)^{1/3} + C \quad \text{[given]}
 \end{aligned}$$

On comparing both sides, we get

$$f(x) = -\frac{1}{2x^2}$$

$$8. \text{ Let } I = \int \frac{\sin \frac{5x}{2}}{\sin \frac{x}{2}} dx = \int \frac{2 \sin \frac{5x}{2} \cos \frac{x}{2}}{2 \sin \frac{x}{2} \cos \frac{x}{2}} dx$$

[multiplying by $2 \cos \frac{x}{2}$ in numerator and denominator]

$$\begin{aligned}
 &= \int \frac{\sin 3x + \sin 2x}{\sin x} dx \\
 & \quad [\because 2 \sin A \cos B = \sin(A+B) + \sin(A-B) \text{ and } \sin 2A = 2 \sin A \cos A] \\
 &= \int \frac{(3 \sin x - 4 \sin^3 x) + 2 \sin x \cos x}{\sin x} dx \\
 & \quad [\because \sin 3x = 3 \sin x - 4 \sin^3 x] \\
 &= \int (3 - 4 \sin^2 x + 2 \cos x) dx
 \end{aligned}$$

$$\begin{aligned}
 &= \int [3 - 2(1 - \cos 2x) + 2 \cos x] dx \\
 & \quad [\because 2 \sin^2 x = 1 - \cos 2x] \\
 &= \int [3 - 2 + 2 \cos 2x + 2 \cos x] dx \\
 &= \int [1 + 2 \cos 2x + 2 \cos x] dx \\
 &= x + 2 \sin x + \sin 2x + C
 \end{aligned}$$

9. Let

$$I = \int \frac{3x^{13} + 2x^{11}}{(2x^4 + 3x^2 + 1)^4} dx = \int \frac{\frac{3}{x^3} + \frac{2}{x^5}}{\left(2 + \frac{3}{x^2} + \frac{1}{x^4}\right)^4} dx$$

[on dividing numerator and denominator by x^6]

Now, put $2 + \frac{3}{x^2} + \frac{1}{x^4} = t$

$$\Rightarrow \left(\frac{-6}{x^3} - \frac{4}{x^5}\right) dx = dt$$

$$\Rightarrow \left(\frac{3}{x^3} + \frac{2}{x^5}\right) dx = -\frac{dt}{2}$$

$$\text{So, } I = \int -\frac{dt}{2t^4} = -\frac{1}{2} \times \frac{t^{-4+1}}{-4+1} + C = \frac{1}{6t^3} + C$$

$$\begin{aligned}
 &= \frac{1}{6 \left(2 + \frac{3}{x^2} + \frac{1}{x^4}\right)^3} + C \quad \left[\because t = 2 + \frac{3}{x^2} + \frac{1}{x^4} \right] \\
 &= \frac{x^{12}}{6(2x^4 + 3x^2 + 1)^3} + C
 \end{aligned}$$

10. We have,

$$\int \frac{x+1}{\sqrt{2x-1}} dx = f(x) \sqrt{2x-1} + C \quad \dots(i)$$

$$\text{Let } I = \int \frac{x+1}{\sqrt{2x-1}} dx$$

Put $2x-1 = t^2$

$$\Rightarrow 2dx = 2t dt \Rightarrow dx = t dt$$

$$I = \int \frac{\frac{t^2+1}{2} + 1}{t} t dt = \frac{1}{2} \int (t^2 + 3) dt$$

$$\left[\because 2x-1 = t^2 \Rightarrow x = \frac{t^2+1}{2} \right]$$

$$= \frac{1}{2} \left(\frac{t^3}{3} + 3t \right) + C = \frac{t}{6} (t^2 + 9) + C$$

$$= \frac{\sqrt{2x-1}}{6} (2x-1+9) + C \quad [\because t = \sqrt{2x-1}]$$

$$= \frac{\sqrt{2x-1}}{6} (2x+8) + C$$

$$= \frac{x+4}{3} \sqrt{2x-1} + C$$

On comparing it with Eq. (i), we get

$$f(x) = \frac{x+4}{3}$$

11. We have,

$$\int \frac{\sqrt{1-x^2}}{x^4} dx = A(x) (\sqrt{1-x^2})^m + C \quad \dots (i)$$

$$\text{Let } I = \int \frac{\sqrt{1-x^2}}{x^4} dx = \int \frac{\sqrt{x^2\left(\frac{1}{x^2}-1\right)}}{x^4} dx$$

$$= \int \frac{x\sqrt{\frac{1}{x^2}-1}}{x^4} dx = \int \frac{1}{x^3} \sqrt{\frac{1}{x^2}-1} dx$$

$$\text{Put } \frac{1}{x^2} - 1 = t^2 \Rightarrow \frac{-2}{x^3} dx = 2t dt \Rightarrow \frac{1}{x^3} dx = -t dt$$

$$\begin{aligned} \therefore I &= -\int t^2 dt = -\frac{t^3}{3} + C \\ &= -\frac{1}{3} \cdot \left(\frac{1-x^2}{x^2}\right)^{3/2} + C \left[\because t = \left(\frac{1}{x^2}-1\right)^{1/2}\right] \\ &= -\frac{1}{3} \frac{1}{x^3} (\sqrt{1-x^2})^3 + C \quad \dots(ii) \end{aligned}$$

On comparing Eqs. (i) and (ii), we get

$$A(x) = -\frac{1}{3x^3} \text{ and } m = 3$$

$$\therefore (A(x))^m = (A(x))^3 = -\frac{1}{27x^9}$$

12. Let $I = \int \frac{(\sin^n \theta - \sin \theta)^{1/n} \cos \theta}{\sin^{n+1} \theta} d\theta$

Put $\sin \theta = t \Rightarrow \cos \theta d\theta = dt$

$$\begin{aligned} \therefore I &= \int \frac{(t^n - t)^{1/n}}{t^{n+1}} dt = \int \frac{\left[t^n\left(1 - \frac{t}{t^n}\right)\right]^{1/n}}{t^{n+1}} dt \\ &= \int \frac{t(1 - 1/t^{n-1})^{1/n}}{t^{n+1}} dt = \int \frac{(1 - 1/t^{n-1})^{1/n}}{t^n} dt \end{aligned}$$

Put $1 - \frac{1}{t^{n-1}} = u$

or $1 - t^{-(n-1)} = u \Rightarrow \frac{(n-1)}{t^n} dt = du$

$$\Rightarrow \frac{dt}{t^n} = \frac{du}{n-1}$$

$$\Rightarrow I = \int \frac{u^{1/n} du}{n-1} = \frac{u^{\frac{1}{n}+1}}{(n-1)\left(\frac{1}{n}+1\right)} + C$$

$$= \frac{n\left(1 - \frac{1}{t^{n-1}}\right)^{\frac{n+1}{n}}}{(n-1)(n+1)} + C$$

$$= \frac{n\left(1 - \frac{1}{\sin^{n-1} \theta}\right)^{\frac{n+1}{n}}}{n^2 - 1} + C$$

$$\left[\because u = 1 - \frac{1}{t^{n-1}} \text{ and } t = \sin \theta\right]$$

13. We have, $f(x) = \int \frac{5x^8 + 7x^6}{(x^2 + 1 + 2x^7)^2} dx$

$$= \int \frac{5\left(\frac{x^8}{x^{14}}\right) + 7\left(\frac{x^6}{x^{14}}\right)}{\left(\frac{x^2}{x^7} + \frac{1}{x^7} + \frac{2x^7}{x^7}\right)^2} dx$$

(dividing both numerator and denominator by x^{14})

$$= \int \frac{5x^{-6} + 7x^{-8}}{(x^{-5} + x^{-7} + 2)^2} dx$$

Let $x^{-5} + x^{-7} + 2 = t$

$$\Rightarrow (-5x^{-6} - 7x^{-8})dx = dt$$

$$\Rightarrow (5x^{-6} + 7x^{-8})dx = -dt$$

$$\therefore f(x) = \int -\frac{dt}{t^2} = -\int t^{-2} dt$$

$$= -\frac{t^{-2+1}}{-2+1} + C = -\frac{t^{-1}}{-1} + C = \frac{1}{t} + C$$

$$= \frac{1}{x^{-5} + x^{-7} + 2} + C = \frac{x^7}{2x^7 + x^2 + 1} + C$$

$\therefore f(0) = 0$

$$\therefore 0 = \frac{0}{0+0+1} + C \Rightarrow C = 0$$

$$\therefore f(x) = \frac{x^7}{2x^7 + x^2 + 1}$$

$$\Rightarrow f(1) = \frac{1}{2(1)^7 + 1^2 + 1} = \frac{1}{4}$$

14. Let $I = \int x \sqrt{\frac{2\sin(x^2-1) - \sin 2(x^2-1)}{2\sin(x^2-1) + \sin 2(x^2-1)}} dx$

Put $\frac{x^2-1}{2} = \theta$

$$\Rightarrow x^2 - 1 = 2\theta$$

$$\Rightarrow 2x dx = 2 d\theta$$

$$\Rightarrow x dx = d\theta$$

Now, $I = \int \sqrt{\frac{2\sin 2\theta - \sin 4\theta}{2\sin 2\theta + \sin 4\theta}} d\theta$

$$= \int \sqrt{\frac{2\sin 2\theta - 2\sin 2\theta \cos 2\theta}{2\sin 2\theta + 2\sin 2\theta \cos 2\theta}} d\theta$$

($\because \sin 2A = 2\sin A \cos A$)

$$= \int \sqrt{\frac{2\sin 2\theta(1 - \cos 2\theta)}{2\sin 2\theta(1 + \cos 2\theta)}} d\theta$$

$$= \int \sqrt{\frac{1 - \cos 2\theta}{1 + \cos 2\theta}} d\theta = \int \sqrt{\frac{2\sin^2 \theta}{2\cos^2 \theta}} d\theta$$

[$\because 1 - \cos 2A = 2\sin^2 A$ and $1 + \cos 2A = 2\cos^2 A$]

$$= \int \sqrt{\tan^2 \theta} d\theta = \int \tan \theta d\theta$$

$$= \log_e |\sec \theta| + C = \log_e \left| \sec \left(\frac{x^2-1}{2} \right) \right| + C \left[\because \theta = \frac{x^2-1}{2} \right]$$

286 Indefinite Integration

15. We have,

$$\begin{aligned} I &= \int \frac{\sin^2 x \cdot \cos^2 x}{(\sin^5 x + \cos^3 x \cdot \sin^2 x + \sin^3 x \cdot \cos^2 x + \cos^5 x)^2} dx \\ &= \int \frac{\sin^2 x \cos^2 x}{\{\sin^3 x(\sin^2 x + \cos^2 x) + \cos^3 x(\sin^2 x + \cos^2 x)\}^2} dx \\ &= \int \frac{\sin^2 x \cos^2 x}{(\sin^3 x + \cos^3 x)^2} dx = \int \frac{\sin^2 x \cos^2 x}{\cos^6 x(1 + \tan^3 x)^2} dx \\ &= \int \frac{\tan^2 x \sec^2 x}{(1 + \tan^3 x)^2} dx \end{aligned}$$

Put $\tan^3 x = t \Rightarrow 3 \tan^2 x \sec^2 x dx = dt$

$$\therefore I = \frac{1}{3} \int \frac{dt}{(1+t)^2}$$

$$\Rightarrow I = \frac{-1}{3(1+t)} + C$$

$$\Rightarrow I = \frac{-1}{3(1+\tan^3 x)} + C$$

16. $\int \frac{dx}{x^2(x^4+1)^{3/4}} = \int \frac{dx}{x^5 \left(1 + \frac{1}{x^4}\right)^{3/4}}$

Put $1 + \frac{1}{x^4} = t^4$

$$\Rightarrow \frac{-4}{x^5} dx = 4t^3 dt$$

$$\Rightarrow \frac{dx}{x^5} = -t^3 dt$$

Hence, the integral becomes

$$\int \frac{-t^3 dt}{t^3} = -\int dt = -t + c = -\left(1 + \frac{1}{x^4}\right)^{1/4} + c$$

17. PLAN Integration by Substitution

i.e. $I = \int f\{g(x)\} \cdot g'(x) dx$

Put $g(x) = t \Rightarrow g'(x) dx = dt$

$$\therefore I = \int f(t) dt$$

Description of Situation Generally, students gets confused after substitution, i.e. $\sec x + \tan x = t$.

Now, for $\sec x$, we should use

$$\sec^2 x - \tan^2 x = 1$$

$$\Rightarrow (\sec x - \tan x)(\sec x + \tan x) = 1$$

$$\Rightarrow \sec x - \tan x = \frac{1}{t}$$

Here, $I = \int \frac{\sec^2 x}{(\sec x + \tan x)^{9/2}}$

Put $\sec x + \tan x = t$

$$\Rightarrow (\sec x \tan x + \sec^2 x) dx = dt$$

$$\Rightarrow \sec x \cdot t dx = dt \Rightarrow \sec x dx = \frac{dt}{t}$$

$$\therefore \sec x - \tan x = \frac{1}{t} \Rightarrow \sec x = \frac{1}{2} \left(t + \frac{1}{t} \right)$$

$$\therefore I = \int \frac{\sec x \cdot \sec x dx}{(\sec x + \tan x)^{9/2}}$$

$$\begin{aligned} \Rightarrow I &= \int \frac{\frac{1}{2} \left(t + \frac{1}{t} \right) \cdot \frac{dt}{t}}{t^{9/2}} = \frac{1}{2} \int \left(\frac{1}{t^{9/2}} + \frac{1}{t^{13/2}} \right) dt \\ &= -\frac{1}{2} \left\{ \frac{2}{7t^{7/2}} + \frac{2}{11t^{11/2}} \right\} + K \\ &= -\left[\frac{1}{7(\sec x + \tan x)^{7/2}} + \frac{1}{11(\sec x + \tan x)^{11/2}} \right] + K \\ &= \frac{-1}{(\sec x + \tan x)^{11/2}} \left\{ \frac{1}{11} + \frac{1}{7} (\sec x + \tan x)^2 \right\} + K \end{aligned}$$

18. Since, $I = \int \frac{e^x}{e^{4x} + e^{2x} + 1} dx$ and $J = \int \frac{e^{3x}}{1 + e^{2x} + e^{4x}} dx$

$$\therefore J - I = \int \frac{(e^{3x} - e^x)}{1 + e^{2x} + e^{4x}} dx$$

Put $e^x = u \Rightarrow e^x dx = du$

$$\therefore J - I = \int \frac{(u^2 - 1)}{1 + u^2 + u^4} du = \int \frac{\left(1 - \frac{1}{u^2}\right)}{1 + \frac{1}{u^2} + u^2} du$$

$$= \int \frac{\left(1 - \frac{1}{u^2}\right)}{\left(u + \frac{1}{u}\right)^2 - 1} du$$

Put $u + \frac{1}{u} = t$

$$\Rightarrow \left(1 - \frac{1}{u^2}\right) du = dt$$

$$= \int \frac{dt}{t^2 - 1} = \frac{1}{2} \log \left| \frac{t-1}{t+1} \right| + c$$

$$= \frac{1}{2} \log \left| \frac{u^2 - u + 1}{u^2 + u + 1} \right| + c$$

$$= \frac{1}{2} \log \left| \frac{e^{2x} - e^x + 1}{e^{2x} + e^x + 1} \right| + c$$

19. Given, $f(x) = \frac{x}{(1+x^n)^{1/n}}$ for $n \geq 2$

$$\therefore ff(x) = \frac{f(x)}{[1+f(x)^n]^{1/n}} = \frac{x}{(1+2x^n)^{1/n}}$$

and $fff(x) = \frac{x}{(1+3x^n)^{1/n}}$

$$\therefore g(x) = \underbrace{(fofo \dots of)}_{n \text{ times}}(x) = \frac{x}{(1+nx^n)^{1/n}}$$

Let $I = \int x^{n-2} g(x) dx = \int \frac{x^{n-1} dx}{(1+nx^n)^{1/n}}$

$$= \frac{1}{n^2} \int \frac{n^2 x^{n-1} dx}{(1+nx^n)^{1/n}} = \frac{1}{n^2} \int \frac{d(1+nx^n)}{(1+nx^n)^{1/n}} dx$$

$$I = \frac{1}{n(n-1)} (1+nx^n)^{1-\frac{1}{n}} + c$$

20. Let $I = \int \frac{(x^2 - 1) dx}{x^3 \sqrt{2x^4 - 2x^2 + 1}}$
 [dividing numerator and denominator by x^5]
 $= \int \frac{\left(\frac{1}{x^3} - \frac{1}{x^5}\right) dx}{\sqrt{2 - \frac{2}{x^2} + \frac{1}{x^4}}}$
 Put $2 - \frac{2}{x^2} + \frac{1}{x^4} = t$
 $\Rightarrow \left(\frac{4}{x^3} - \frac{4}{x^5}\right) dx = dt$
 $\therefore I = \frac{1}{4} \int \frac{dt}{\sqrt{t}} = \frac{1}{4} \cdot \frac{t^{1/2}}{1/2} + c$
 $= \frac{1}{2} \sqrt{2 - \frac{2}{x^2} + \frac{1}{x^4}} + c$

21. We have, $f'(x) = e^{f(x)-g(x)} g'(x) \forall x \in R$
 $\Rightarrow f'(x) = \frac{e^{f(x)}}{e^{g(x)}} g'(x)$
 $\Rightarrow \frac{f'(x)}{e^{f(x)}} = \frac{g'(x)}{e^{g(x)}}$
 $\Rightarrow e^{-f(x)} f'(x) = e^{-g(x)} g'(x)$
 On integrating both side, we get
 $e^{-f(x)} = e^{-g(x)} + C$
 At $x = 1$
 $e^{-f(1)} = e^{-g(1)} + C$
 $e^{-1} = e^{-g(1)} + C \quad [\because f(1) = 1] \quad \dots(i)$
 At $x = 2$
 $e^{-f(2)} = e^{-g(2)} + C$
 $\Rightarrow e^{-f(2)} = e^{-1} + C \quad [\because g(2) = 1] \quad \dots(ii)$
 From Eqs. (i) and (ii)
 $e^{-f(2)} = 2e^{-1} - e^{-g(1)} \quad \dots(iii)$
 $\Rightarrow e^{-f(2)} > 2e^{-1}$
 We know that, e^{-x} is decreasing
 $\therefore -f(2) < \log_e 2 - 1$
 $f(2) > 1 - \log_e 2$
 $\Rightarrow e^{-g(1)} + e^{-f(2)} = 2e^{-1} \quad [\text{from Eq. (iii)}]$
 $\Rightarrow e^{-g(1)} < 2e^{-1}$
 $-g(1) < \log_e 2 - 1$
 $\Rightarrow g(1) > 1 - \log_e 2$

22. Given,
 $f(x+y) = f(x)f'(y) + f'(x)f(y), \forall x, y \in R$
 and $f(0) = 1$
 Put $x = y = 0$, we get
 $f(0) = f(0)f'(0) + f'(0)f(0)$
 $\Rightarrow 1 = 2f'(0) \Rightarrow f'(0) = \frac{1}{2}$
 Put $x = x$ and $y = 0$, we get
 $f(x) = f(x)f'(0) + f'(x)f(0)$

$$\Rightarrow f(x) = \frac{1}{2} f(x) + f'(x)$$

$$\Rightarrow f'(x) = \frac{1}{2} f(x) \Rightarrow \frac{f'(x)}{f(x)} = \frac{1}{2}$$

On integrating, we get
 $\log f(x) = \frac{1}{2} x + C$
 $\Rightarrow f(x) = Ae^{\frac{1}{2}x}$, where $e^C = A$
 If $f(0) = 1$, then $A = 1$
 Hence, $f(x) = e^{\frac{1}{2}x}$
 $\Rightarrow \log_e f(x) = \frac{1}{2} x \Rightarrow \log_e f(4) = \frac{1}{2} \times 4 = 2$

23. Given, $\int \frac{4e^x + 6e^{-x}}{9e^x - 4e^{-x}} dx = Ax + B \log(9e^{2x} - 4) + c$

$$\text{LHS} = \int \frac{4e^{2x} + 6}{9e^{2x} - 4} dx$$

$$\text{Let } 4e^{2x} + 6 = A(9e^{2x} - 4) + B(18e^{2x})$$

$$\Rightarrow 9A + 18B = 4 \quad \text{and} \quad -4A = 6$$

$$\Rightarrow A = -\frac{3}{2} \quad \text{and} \quad B = \frac{35}{36}$$

$$\therefore \int \frac{A(9e^{2x} - 4) + B(18e^{2x})}{9e^{2x} - 4} dx = A \int 1 dx + B \int \frac{1}{t} dt$$

$$\text{where } t = 9e^{2x} - 4$$

$$= Ax + B \log(9e^{2x} - 4) + c$$

$$= -\frac{3}{2} x + \frac{35}{36} \log(9e^{2x} - 4) + c$$

$$\therefore A = -\frac{3}{2}, B = \frac{35}{36}$$

and $c = \text{any real number}$

24. For any natural number m , the given integral can be written as

$$I = \int (x^{3m} + x^{2m} + x^m) \frac{(2x^{3m} + 3x^{2m} + 6x^m)^{1/m}}{x} dx$$

$$\Rightarrow I = \int (2x^{3m} + 3x^{2m} + 6x^m)^{1/m} (x^{3m-1} + x^{2m-1} + x^{m-1}) dx$$

$$\text{Put } 2x^{3m} + 3x^{2m} + 6x^m = t$$

$$\Rightarrow (6mx^{3m-1} + 6mx^{2m-1} + 6mx^{m-1}) dx = dt$$

$$\therefore I = \int t^{1/m} \frac{dt}{6m} = \frac{1}{6m} \cdot \frac{t^{\frac{1}{m}+1}}{\left(\frac{1}{m}+1\right)}$$

$$= \frac{1}{6(m+1)} \cdot (2x^{3m} + 3x^{2m} + 6x^m)^{(m+1)/m} + c$$

25. Let $I = \int \left(\frac{1-\sqrt{x}}{1+\sqrt{x}}\right)^{1/2} \cdot \frac{dx}{x}$

$$\text{Put } x = \cos^2 \theta \Rightarrow dx = -2 \cos \theta \sin \theta d\theta$$

288 Indefinite Integration

$$\begin{aligned} \therefore I &= \int \left(\frac{1 - \cos \theta}{1 + \cos \theta} \right)^{1/2} \cdot \frac{-2 \cos \theta \cdot \sin \theta}{\cos^2 \theta} d\theta \\ &= \int \frac{\sin \frac{\theta}{2}}{\cos \frac{\theta}{2}} \cdot \frac{-2 \sin \theta}{\cos \theta} d\theta \\ &= - \int \frac{2 \sin \frac{\theta}{2} \cdot 2 \sin \frac{\theta}{2} \cdot \cos \frac{\theta}{2}}{\cos \frac{\theta}{2} \cdot \cos \theta} d\theta - 2 \int \frac{2 \sin^2 \frac{\theta}{2}}{\cos \theta} d\theta \\ &= -2 \int \frac{1 - \cos \theta}{\cos \theta} d\theta \\ &= 2 \int (1 - \sec \theta) d\theta = 2 [\theta - \log |\sec \theta + \tan \theta|] + c \end{aligned}$$

$$\Rightarrow I = 2 \left[\cos^{-1} \sqrt{x} - \log \left| \frac{1}{\sqrt{x}} + \sqrt{\frac{1}{x} - 1} \right| \right] + c$$

$$\Rightarrow I = 2 \left[\cos^{-1} \sqrt{x} - \log |1 + \sqrt{1-x}| - \frac{1}{2} \log |x| \right] + c$$

26. Let $I = \int \sqrt{\frac{1-\sqrt{x}}{1+\sqrt{x}}} dx$

Put $x = \cos^2 \theta \Rightarrow dx = -2 \sin \theta \cos \theta d\theta$

$$\begin{aligned} \therefore I &= \int \sqrt{\frac{1 - \cos \theta}{1 + \cos \theta}} \cdot (-2 \sin \theta \cos \theta) d\theta \\ &= - \int 2 \tan \frac{\theta}{2} \cdot \sin \theta \cos \theta d\theta = -2 \int 2 \sin^2 \frac{\theta}{2} \cdot \cos \theta d\theta \\ &= -2 \int (1 - \cos \theta) \cos \theta d\theta = -2 \int (\cos \theta - \cos^2 \theta) d\theta \\ &= -2 \int \cos \theta d\theta + \int (1 + \cos 2\theta) d\theta \\ &= -2 \sin \theta + \theta + \frac{\sin 2\theta}{2} + c \\ &= -2 \sqrt{1-x} + \cos^{-1} \sqrt{x} + \sqrt{x(1-x)} + c \end{aligned}$$

27. Let $I = \int \frac{dx}{x^2 (x^4 + 1)^{3/4}} = \int \frac{dx}{x^2 \cdot x^3 \left(1 + \frac{1}{x^4}\right)^{3/4}}$

Put $1 + x^{-4} = t \Rightarrow -\frac{4}{x^5} dx = dt$

$$\begin{aligned} \therefore I &= -\frac{1}{4} \int \frac{dt}{t^{3/4}} = -\frac{1}{4} \cdot \frac{t^{1/4}}{1/4} + c = -\left(1 + \frac{1}{x^4}\right)^{1/4} + c \\ &= -\frac{(x^4 + 1)^{1/4}}{x} + c \end{aligned}$$

28. (i) Let $I = \int \sqrt{1 + \sin \frac{x}{2}} dx$

$$\begin{aligned} &= \int \sqrt{\cos^2 \frac{x}{4} + \sin^2 \frac{x}{4} + 2 \sin \frac{x}{4} \cos \frac{x}{4}} dx \\ &= \int \left(\cos \frac{x}{4} + \sin \frac{x}{4} \right) dx \\ &= 4 \sin \frac{x}{4} - 4 \cos \frac{x}{4} + c \end{aligned}$$

(ii) Let $I = \int \frac{x^2}{\sqrt{1-x}} dx$

Put $1 - x = t^2 \Rightarrow -dx = 2t dt$

$$\begin{aligned} \therefore I &= \int \frac{(1-t^2)^2 \cdot (-2t) dt}{t} \\ &= -2 \int (1 - 2t^2 + t^4) dt \\ &= -2 \left(t - \frac{2t^3}{3} + \frac{t^5}{5} \right) + c \\ &= -2 \left\{ \sqrt{1-x} - \frac{2}{3} (1-x)^{3/2} + \frac{1}{5} (1-x)^{5/2} \right\} + c \end{aligned}$$

29. Let $I = \frac{x^2}{(a+bx)^2}$

Put $a + bx = t \Rightarrow b dx = dt$

$$\begin{aligned} \therefore I &= \int \frac{\left(\frac{t-a}{b}\right)^2}{t^2} \cdot \frac{dt}{b} \\ &= \frac{1}{b^3} \int \left(\frac{t^2 - 2at + a^2}{t^2} \right) dt \\ &= \frac{1}{b^3} \int \left(1 - \frac{2a}{t} + \frac{a^2}{t^2} \right) dt \\ &= \frac{1}{b^3} \left(t - 2a \log t - \frac{a^2}{t} \right) + c \\ &= \frac{1}{b^3} \left(a + bx - 2a \log(a + bx) - \frac{a^2}{a + bx} + c \right) \end{aligned}$$

30. Let $I_1 = \int \sin x \sin 2x \sin 3x dx$

$$\begin{aligned} &= \frac{1}{4} \int (\sin 4x + \sin 2x - \sin 6x) dx \\ &= -\frac{\cos 4x}{16} - \frac{\cos 2x}{8} + \frac{\cos 6x}{24} \end{aligned}$$

$$\begin{aligned} I_2 &= \int \sec^2 x \cdot \cos^2 2x dx \\ &= \int \sec^2 x (2 \cos^2 x - 1)^2 dx \\ &= \int (4 \cos^2 x + \sec^2 x - 4) dx \\ &= \int (2 \cos 2x + \sec^2 x - 2) dx \\ &= \sin 2x + \tan x - 2x \end{aligned}$$

and $I_3 = \int \sin^4 x \cos^4 x dx$

$$\begin{aligned} &= \frac{1}{128} \int (3 - 4 \cos 4x + \cos 8x) dx \\ &= \frac{3x}{128} - \frac{\sin 4x}{128} + \frac{\sin 8x}{1024} \end{aligned}$$

$$\begin{aligned} \therefore I &= I_1 + I_2 + I_3 \\ &= -\frac{\cos 4x}{16} - \frac{\cos 2x}{8} + \frac{\cos 6x}{24} + \sin 2x + \tan x - 2x \\ &\quad + \frac{3x}{128} - \frac{\sin 4x}{128} + \frac{\sin 8x}{1024} \end{aligned}$$

31. Let $I = \int \frac{x dx}{1+x^4} = \frac{1}{2} \int \frac{2x}{1+(x^2)^2} dx$

Put $x^2 = u \Rightarrow 2x dx = du$

$\therefore I = \frac{1}{2} \int \frac{du}{1+u^2} = \frac{1}{2} \tan^{-1}(u) + c = \frac{1}{2} \tan^{-1}(x^2) + c$

32. Let $I = \int \frac{\sin x}{\sin x - \cos x} dx$

Again, let $\sin x = A(\cos x + \sin x) + B(\sin x - \cos x)$, then $A + B = 1$ and $A - B = 0$

$\Rightarrow A = \frac{1}{2}, B = \frac{1}{2}$

$\therefore I = \int \frac{\frac{1}{2}(\cos x + \sin x) + \frac{1}{2}(\sin x - \cos x)}{(\sin x - \cos x)} dx$
 $= \frac{1}{2} \int \frac{\cos x + \sin x}{\sin x - \cos x} dx + \frac{1}{2} \int 1 dx + c$
 $= \frac{1}{2} \log(\sin x - \cos x) + \frac{1}{2} x + c$

Topic 2 Some Special Integrals

1. Let $I = \int \sec^{\frac{2}{3}} x \cos^{\frac{4}{3}} x dx = \int \frac{dx}{\cos^{\frac{2}{3}} x \sin^{\frac{4}{3}} x}$

$\int \frac{dx}{\left(\frac{\sin x}{\cos x}\right)^{\frac{4}{3}} \cos^{\frac{2}{3}} x \cos^{\frac{2}{3}} x}$

[dividing and multiplying by $\cos^{4/3} x$ in denominator]

$= \int \frac{dx}{\tan^{\frac{4}{3}} x \cos^2 x} = \int \frac{\sec^2 x dx}{(\tan x)^{\frac{4}{3}}}$

Now, put $\tan x = t \Rightarrow \sec^2 x dx = dt$

$\therefore I = \int \frac{dt}{t^{4/3}} = \frac{t^{-4/3+1}}{-4/3+1} + C$

$= -3 \frac{1}{t^{1/3}} + C = \frac{-3}{(\tan x)^{1/3}} + C = -3 \tan^{-\frac{1}{3}} x + C$

2. We have, $I_n = \int \tan^n x dx$

$\therefore I_n + I_{n+2} = \int \tan^n x dx + \int \tan^{n+2} x dx$
 $= \int \tan^n x (1 + \tan^2 x) dx$
 $= \int \tan^n x \sec^2 x dx = \frac{\tan^{n+1} x}{n+1} + C$

Put $n = 4$, we get $I_4 + I_6 = \frac{\tan^5 x}{5} + C$

$\therefore a = \frac{1}{5}$ and $b = 0$

3. Let $I = \int \left(\frac{1}{\sqrt[3]{x} + \sqrt[4]{x}} + \frac{\ln(1 + \sqrt[6]{x})}{\sqrt[3]{x} + \sqrt{x}} \right) dx$

$\therefore I = I_1 + I_2$

where, $I_1 = \int \left(\frac{1}{\sqrt[3]{x} + \sqrt[4]{x}} \right) dx$,

$I_2 = \int \frac{\ln(1 + \sqrt[6]{x})}{\sqrt[3]{x} + \sqrt{x}} dx$

Now, $I_1 = \int \left(\frac{1}{\sqrt[3]{x} + \sqrt[4]{x}} \right) dx$

Put $x = t^{12} \Rightarrow dx = 12 t^{11} dt$

$\therefore I_1 = 12 \int \frac{t^{11}}{t^4 + t^3} dt$

$= 12 \int \frac{t^8 dt}{t+1}$

$= 12 \int (t^7 - t^6 + t^5 - t^4 + t^3 - t^2 + t - 1) dt$

$+ 12 \int \frac{dt}{t+1}$

$= 12 \left(\frac{t^8}{8} - \frac{t^7}{7} + \frac{t^6}{6} - \frac{t^5}{5} + \frac{t^4}{4} - \frac{t^3}{3} + \frac{t^2}{2} - t \right)$

$+ 12 \ln(t+1)$

and $I_2 = \int \left\{ \frac{\ln(1 + \sqrt[6]{x})}{\sqrt[3]{x} + \sqrt{x}} \right\} dx$

Put $x = u^6 \Rightarrow dx = 6u^5 du$

$\therefore I_2 = \int \frac{\ln(1+u)}{u^2 + u^3} 6u^5 du = \int \frac{\ln(1+u)}{u^2(1+u)} \cdot 6u^5 du$

$= 6 \int \frac{u^3}{(u+1)} \ln(1+u) du$

$= 6 \int \left(\frac{u^3 - 1 + 1}{u+1} \right) \ln(1+u) du$

$= 6 \int \left(u^2 - u + 1 - \frac{1}{u+1} \right) \ln(1+u) du$

$= 6 \int (u^2 - u + 1) \ln(1+u) du - 6 \int \frac{\ln(1+u)}{(u+1)} du$

$= 6 \left(\frac{u^3}{3} - \frac{u^2}{2} + u \right) \ln(1+u)$

$- \int \frac{2u^3 - 3u^2 + 6u}{u+1} du - 6 \frac{1}{2} [\ln(1+u)]^2$

$= (2u^3 - 3u^2 + 6u) \ln(1+u)$

$- \int \left(2u^2 - 5u + \frac{11u}{u+1} \right) du - 3 [\ln(1+u)]^2$

$= (2u^3 - 3u^2 + 6u) \ln(1+u)$

$- \left(\frac{2u^3}{3} - \frac{5}{2}u^2 + 11u - 11 \ln(u+1) \right) - 3 [\ln(1+u)]^2$

290 Indefinite Integration

$$\begin{aligned} \therefore I &= \frac{3}{2}x^{2/3} - \frac{12}{7}x^{7/12} + 2x^{1/2} - \frac{12}{5}x^{5/12} + 3x^{1/3} - 4x^{1/4} \\ &\quad - 6x^{1/6} - 12x^{1/12} + 12 \ln(x^{1/12} + 1) \\ &\quad + (2x^{1/2} - 3x^{1/3} + 6x^{1/6}) \ln(1 + x^{1/6}) \\ &\quad - \left[\frac{2}{3}x^{1/2} - \frac{5}{2}x^{1/3} + 11x^{1/6} - 11 \ln(1 + x^{1/6}) \right] \\ &\quad - 3 [\ln(1 + x^{1/6})]^2 + c \\ &= \frac{3}{2}x^{2/3} - \frac{12}{7}x^{7/12} + \frac{4}{3}x^{1/2} - \frac{12}{5}x^{5/12} \\ &\quad + \frac{1}{2}x^{1/3} - 4x^{1/4} - 7x^{1/6} - 12x^{1/12} \\ &\quad + (2x^{1/2} - 3x^{1/3} + 6x^{1/6} + 11) \ln(1 + x^{1/6}) \\ &\quad + 12 \ln(1 + x^{1/12}) - 3 [\ln(1 + x^{1/6})]^2 + c \end{aligned}$$

4. Let $I = \int (\sqrt{\tan x} + \sqrt{\cot x}) dx = \int \frac{\tan x + 1}{\sqrt{\tan x}} dx$

Put $\tan x = t^2 \Rightarrow \sec^2 x dx = 2t dt$

$$\Rightarrow dx = \frac{2t}{1+t^4} dt$$

$$\begin{aligned} \therefore I &= \int \frac{t^2 + 1}{\sqrt{t^2}} \cdot \frac{2t}{t^4 + 1} dt = 2 \int \frac{t^2 + 1}{t^4 + 1} dt \\ &= 2 \int \frac{1 + \frac{1}{t^2}}{t^2 + \frac{1}{t^2} - 2 + 2} dt = 2 \int \frac{1 + \frac{1}{t^2}}{\left(t - \frac{1}{t}\right)^2 + (\sqrt{2})^2} dt \end{aligned}$$

Put $t - \frac{1}{t} = u \Rightarrow 1 + \frac{1}{t^2} dt = du$

$$\therefore I = 2 \int \frac{du}{u^2 + (\sqrt{2})^2}$$

$$\begin{aligned} \Rightarrow I &= \frac{2}{\sqrt{2}} \tan^{-1} \left(\frac{u}{\sqrt{2}} \right) + c \\ &= \sqrt{2} \tan^{-1} \left(\frac{\sqrt{\tan x} - \sqrt{\cot x}}{\sqrt{2}} \right) + c \end{aligned}$$

5. Let $I = \int \frac{\sqrt{\cos 2x}}{\sin x} dx = \int \sqrt{\frac{\cos^2 x - \sin^2 x}{\sin^2 x}} dx$
 $= \int \sqrt{\cot^2 x - 1} dx$

Put $\cot x = \sec \theta \Rightarrow -\operatorname{cosec}^2 x dx = \sec \theta \tan \theta d\theta$

$$\therefore I = \int \sqrt{\sec^2 \theta - 1} \cdot \frac{\sec \theta \cdot \tan \theta}{-(1 + \sec^2 \theta)} d\theta$$

$$= - \int \frac{\sec \theta \cdot \tan^2 \theta}{1 + \sec^2 \theta} d\theta$$

$$= - \int \frac{\sin^2 \theta}{\cos \theta + \cos^3 \theta} d\theta$$

$$= - \int \frac{1 - \cos^2 \theta}{\cos \theta (1 + \cos^2 \theta)} d\theta$$

$$= - \int \frac{(1 + \cos^2 \theta) - 2 \cos^2 \theta}{\cos \theta (1 + \cos^2 \theta)} d\theta$$

$$= - \int \sec \theta d\theta + 2 \int \frac{\cos \theta}{1 + \cos^2 \theta} d\theta$$

$$= - \log |\sec \theta + \tan \theta| + 2 \int \frac{\cos \theta}{2 - \sin^2 \theta} d\theta$$

$$= - \log |\sec \theta + \tan \theta| + \int \frac{dt}{2 - t^2}, \text{ where } \sin \theta = t$$

$$= - \log |\sec \theta + \tan \theta| + 2 \cdot \frac{1}{2\sqrt{2}} \log \left| \frac{\sqrt{2} + \sin \theta}{\sqrt{2} - \sin \theta} \right| + c$$

$$= - \log |\cot x + \sqrt{\cot^2 x - 1}|$$

$$+ \frac{1}{\sqrt{2}} \log \left| \frac{\sqrt{2} + \sqrt{1 - \tan^2 x}}{\sqrt{2} - \sqrt{1 - \tan^2 x}} \right| + c$$

6. Given, $f(x) = \int \left(\frac{2 \sin x - \sin 2x}{x^3} \right) dx$

On differentiating w.r.t. x , we get

$$f'(x) = \frac{2 \sin x - \sin 2x}{x^3} = \frac{2 \sin x}{x} \left(\frac{1 - \cos x}{x^2} \right)$$

$$\lim_{x \rightarrow 0} f'(x) = \lim_{x \rightarrow 0} 2 \left(\frac{\sin x}{x} \right) \left(\frac{2 \sin^2 \frac{x}{2}}{x^2} \right)$$

$$= 4 \cdot \lim_{x \rightarrow 0} \left[\frac{\sin^2 \frac{x}{2}}{4 \left(\frac{x}{2} \right)^2} \right] = 1$$

Topic 3 Integration by Parts

1. Let given integral, $I = \int x^5 e^{-x^2} dx$

Put $x^2 = t \Rightarrow 2x dx = dt$

So, $I = \frac{1}{2} \int t^2 e^{-t} dt$

$$= \frac{1}{2} [(-t^2 e^{-t}) + \int e^{-t} (2t) dt] \quad [\text{Integration by parts}]$$

$$= \frac{1}{2} [-t^2 e^{-t} + 2t(-e^{-t}) + \int 2e^{-t} dt]$$

$$= \frac{1}{2} [-t^2 e^{-t} - 2te^{-t} - 2e^{-t}] + C$$

$$= -\frac{e^{-t}}{2} (t^2 + 2t + 2) + C$$

$$= -\frac{e^{-x^2}}{2} (x^4 + 2x^2 + 2) + C \quad [: t = x^2] \quad \dots(i)$$

\therefore It is given that,

$$I = \int x^5 e^{-x^2} dx = g(x) \cdot e^{-x^2} + C$$

By Eq. (i), comparing both sides, we get

$$g(x) = -\frac{1}{2} (x^4 + 2x^2 + 2)$$

So, $g(-1) = -\frac{1}{2} (1 + 2 + 2) = -\frac{5}{2}$

2. Given, $\int e^{\sec x} [(\sec x \tan x)f(x) + (\sec x \tan x + \sec^2 x)] dx$
 $= e^{\sec x} \cdot f(x) + C$

On differentiating both sides w.r.t. x , we get

$$e^{\sec x} [(\sec x \tan x)f(x) + (\sec x \tan x + \sec^2 x)]$$

$$= e^{\sec x} f'(x) + e^{\sec x} (\sec x \tan x)f(x)$$

$$\Rightarrow e^{\sec x} (\sec x \tan x + \sec^2 x) = e^{\sec x} f'(x)$$

$$\Rightarrow f'(x) = \sec x \tan x + \sec^2 x$$

So, $f(x) = \int f'(x) dx = \int (\sec x \tan x + \sec^2 x) dx$
 $= \sec x + \tan x + C$

So, possible value of $f(x)$ from options, is

$$f(x) = \sec x + \tan x + \frac{1}{2}$$

3. Let $I = \int \cos(\log_e x) dx$

$$= x \cos(\log_e x) - \int x(-\sin(\log_e x)) \frac{1}{x} dx$$

[using integration by parts]

$$= x \cos(\log_e x) + \int \sin(\log_e x) dx$$

$$= x \cos(\log_e x) + x \sin(\log_e x) - \int x(\cos(\log_e x)) \frac{1}{x} dx$$

[again, using integration by parts]

$$\Rightarrow I = x \cos(\log_e x) + x \sin(\log_e x) - I$$

$$\Rightarrow I = \frac{x}{2} [\cos(\log_e x) + \sin(\log_e x)] + C.$$

4. Given, $\int x^5 e^{-4x^3} dx = \frac{1}{48} e^{-4x^3} f(x) + C$

In LHS, put $x^3 = t$

$$\Rightarrow 3x^2 dx = dt$$

So, $\int x^5 e^{-4x^3} dx = \frac{1}{3} \int t e^{-4t} dt$

$$= \frac{1}{3} \left[t \frac{e^{-4t}}{-4} - \int \frac{e^{-4t}}{-4} dt \right]$$

[using integration by parts]

$$= \frac{1}{3} \left[\frac{te^{-4t}}{-4} + \frac{e^{-4t}}{-16} \right] + C$$

$$= -\frac{1}{48} e^{-4t} [4t + 1] + C$$

$$= -\frac{e^{-4x^3}}{48} [4x^3 + 1] + C \quad [\because t = x^3]$$

$\therefore f(x) = -1 - 4x^3$ (comparing with given equation)

5. $\int \left(1 + x - \frac{1}{x}\right) e^{x + \frac{1}{x}} dx$

$$= \int e^{x + \frac{1}{x}} dx + \int x \left(1 - \frac{1}{x^2}\right) e^{x + \frac{1}{x}} dx$$

$$= \int e^{x + \frac{1}{x}} dx + xe^{x + \frac{1}{x}} - \int \frac{d}{dx} (x) e^{x + \frac{1}{x}} dx$$

$$= \int e^{x + \frac{1}{x}} dx + xe^{x + \frac{1}{x}} - \int e^{x + \frac{1}{x}} dx$$

$$\left[\because \int \left(1 - \frac{1}{x^2}\right) e^{x + \frac{1}{x}} dx = e^{x + \frac{1}{x}} \right]$$

$$= \int e^{x + \frac{1}{x}} dx + xe^{x + \frac{1}{x}} - \int e^{x + \frac{1}{x}} dx = xe^{x + \frac{1}{x}} + c$$

6. Given, $\int f(x) dx = \psi(x)$

Let $I = \int x^5 f(x^3) dx$

Put $x^3 = t$

$$\Rightarrow x^2 dx = \frac{dt}{3} \quad \dots(i)$$

$$\therefore I = \frac{1}{3} \int t f(t) dt$$

$$= \frac{1}{3} \left[t \cdot \int f(t) dt - \int \left\{ \frac{d}{dt} (t) \int f(t) dt \right\} dt \right]$$

[integration by parts]

$$= \frac{1}{3} [t \psi(t) - \int \psi(t) dt]$$

$$= \frac{1}{3} [x^3 \psi(x^3) - 3 \int x^2 \psi(x^3) dx] + c \quad \text{[from Eq. (i)]}$$

$$= \frac{1}{3} x^3 \psi(x^3) - \int x^2 \psi(x^3) dx + c$$

7. Let $I = \int \sin^{-1} \left(\frac{2x+2}{\sqrt{4x^2+8x+13}} \right) dx$

$$= \int \sin^{-1} \left(\frac{2x+2}{\sqrt{(2x+2)^2+9}} \right) dx$$

Put $2x+2 = 3 \tan \theta \Rightarrow 2 dx = 3 \sec^2 \theta d\theta$

$$\therefore I = \int \sin^{-1} \left(\frac{3 \tan \theta}{\sqrt{9 \tan^2 \theta + 9}} \right) \cdot \frac{3}{2} \sec^2 \theta d\theta$$

$$= \int \sin^{-1} \left(\frac{3 \tan \theta}{3 \sec \theta} \right) \cdot \frac{3}{2} \sec^2 \theta d\theta$$

$$= \int \sin^{-1} \left(\frac{\sin \theta}{\cos \theta \cdot \sec \theta} \right) \cdot \frac{3}{2} \sec^2 \theta d\theta$$

$$= \frac{3}{2} \int \sin^{-1}(\sin \theta) \cdot \sec^2 \theta d\theta$$

$$= \frac{3}{2} \int \theta \cdot \sec^2 \theta d\theta = \frac{3}{2} [\theta \cdot \tan \theta - \int 1 \cdot \tan \theta d\theta]$$

$$= \frac{3}{2} [\theta \tan \theta - \log \sec \theta] + c$$

$$= \frac{3}{2} \left[\tan^{-1} \left(\frac{2x+2}{3} \right) \cdot \left(\frac{2x+2}{3} \right) \right.$$

$$\left. - \log \sqrt{1 + \left(\frac{2x+2}{3} \right)^2} \right] + c_1$$

292 Indefinite Integration

$$\begin{aligned}
 &= (x+1) \tan^{-1}\left(\frac{2x+2}{3}\right) - \frac{3}{4} \log \left[1 + \left(\frac{2x+2}{3}\right)^2 \right] + c_1 \\
 &= (x+1) \tan^{-1}\left(\frac{2x+2}{3}\right) - \frac{3}{4} \log (4x^2 + 8x + 13) + c \\
 &\qquad\qquad\qquad \left[\text{let } \frac{3}{2} \log 3 + c_1 = c \right]
 \end{aligned}$$

8. $I = \int \cos 2\theta \ln \left(\frac{\cos \theta + \sin \theta}{\cos \theta - \sin \theta} \right) d\theta$ [given]

We integrate it by taking parts

$\ln \left(\frac{\cos \theta + \sin \theta}{\cos \theta - \sin \theta} \right)$ as first function

$$\begin{aligned}
 &= \frac{\sin 2\theta}{2} \ln \left(\frac{\cos \theta + \sin \theta}{\cos \theta - \sin \theta} \right) \\
 &\quad - \frac{1}{2} \int \frac{d}{d\theta} \left[\ln \left(\frac{\cos \theta + \sin \theta}{\cos \theta - \sin \theta} \right) \right] \sin 2\theta d\theta \quad \dots(i)
 \end{aligned}$$

But $\frac{d}{d\theta} \left[\ln \left(\frac{\cos \theta + \sin \theta}{\cos \theta - \sin \theta} \right) \right]$

$$\begin{aligned}
 &= \frac{d}{d\theta} [\ln (\cos \theta + \sin \theta) - \ln (\cos \theta - \sin \theta)] \\
 &= \frac{1}{(\cos \theta + \sin \theta)} \cdot (-\sin \theta + \cos \theta) - \frac{(-\sin \theta - \cos \theta)}{\cos \theta - \sin \theta} \\
 &= \frac{(\cos \theta - \sin \theta)(\cos \theta - \sin \theta) - (\cos \theta + \sin \theta)(-\sin \theta - \cos \theta)}{(\cos \theta + \sin \theta)(\cos \theta - \sin \theta)} \\
 &= \frac{\cos^2 \theta - \cos \theta \sin \theta - \sin \theta \cos \theta + \sin^2 \theta + \cos \theta \sin \theta + \cos^2 \theta + \sin^2 \theta + \cos \theta \cdot \sin \theta}{\cos^2 \theta - \sin^2 \theta} \\
 &= \frac{2(\cos^2 \theta + \sin^2 \theta)}{\cos 2\theta} = \frac{2}{\cos 2\theta}
 \end{aligned}$$

Therefore, on putting this value in Eq.(i), we get

$$\begin{aligned}
 I &= \frac{1}{2} \sin 2\theta \ln \left(\frac{\cos \theta + \sin \theta}{\cos \theta - \sin \theta} \right) - \frac{1}{2} \int \sin 2\theta \cdot \frac{2}{\cos 2\theta} d\theta \\
 &= \frac{1}{2} \sin 2\theta \ln \left(\frac{\cos \theta + \sin \theta}{\cos \theta - \sin \theta} \right) + \frac{1}{2} \ln (\cos 2\theta) + c
 \end{aligned}$$

9. Let $I = \int \frac{\sin^{-1} \sqrt{x} - \cos^{-1} \sqrt{x}}{\sin^{-1} \sqrt{x} + \cos^{-1} \sqrt{x}} dx$

$$\begin{aligned}
 &= \int \frac{\sin^{-1} \sqrt{x} - \left(\frac{\pi}{2} - \sin^{-1} \sqrt{x} \right)}{\frac{\pi}{2}} dx \\
 &= \frac{2}{\pi} \int \left(2 \sin^{-1} \sqrt{x} - \frac{\pi}{2} \right) dx = \frac{4}{\pi} \int \sin^{-1} \sqrt{x} dx - x + c \quad \dots(i)
 \end{aligned}$$

Now, $\int \sin^{-1} \sqrt{x} dx$

Put $x = \sin^2 \theta \Rightarrow dx = \sin 2\theta$

$$= \int \theta \cdot \sin 2\theta d\theta = -\frac{\theta \cos 2\theta}{2} + \int \frac{1}{2} \cos 2\theta d\theta$$

$$\begin{aligned}
 &= -\frac{\theta}{2} \cos 2\theta + \frac{1}{4} \sin 2\theta \\
 &= -\frac{1}{2} \theta (1 - 2 \sin^2 \theta) + \frac{1}{2} \sin \theta \sqrt{1 - \sin^2 \theta} \\
 &= -\frac{1}{2} \sin^{-1} \sqrt{x} (1 - 2x) + \frac{1}{2} \sqrt{x} \sqrt{1-x} \quad \dots(ii)
 \end{aligned}$$

From Eqs. (i) and (ii),

$$\begin{aligned}
 I &= \frac{4}{\pi} \left[-\frac{1}{2} (1 - 2x) \sin^{-1} \sqrt{x} + \frac{1}{2} \sqrt{x - x^2} \right] - x + c \\
 &= \frac{2}{\pi} [\sqrt{x - x^2} - (1 - 2x) \sin^{-1} \sqrt{x}] - x + c
 \end{aligned}$$

10. Let $I = \int \frac{(x-1)e^x}{(x+1)^3} dx$

$$\begin{aligned}
 I &= \int \left\{ \frac{x+1-2}{(x+1)^3} \right\} e^x dx = \int \left\{ \frac{1}{(x+1)^2} - \frac{2}{(x+1)^3} \right\} e^x dx \\
 &= \int e^x \cdot \frac{1}{(x+1)^2} dx - 2 \int e^x \cdot \frac{1}{(x+1)^3} dx
 \end{aligned}$$

Applying integration by parts,

$$\begin{aligned}
 &= \left\{ \frac{1}{(x+1)^2} \cdot e^x - \int e^x \cdot \frac{-2}{(x+1)^3} dx \right\} \\
 &\quad - 2 \int e^x \cdot \frac{1}{(x+1)^3} dx = \frac{e^x}{(x+1)^2} + c
 \end{aligned}$$

11. Let $I = \int (e^{\log x} + \sin x) \cos x dx$

$$\begin{aligned}
 &= \int (x + \sin x) \cos x dx \\
 &= \int x \cos x dx + \frac{1}{2} \int (\sin 2x) dx \\
 &= (x \cdot \sin x - \int 1 \cdot \sin x dx) - \frac{\cos 2x}{4} + c \\
 &= x \sin x + \cos x - \frac{\cos 2x}{4} + c
 \end{aligned}$$

Topic 4 Integration, Irrational Function and Partial Fraction

1. Let $I = \int \frac{2x^{12} + 5x^9}{(x^5 + x^3 + 1)^3} dx = \int \frac{2x^{12} + 5x^9}{x^{15} (1 + x^{-2} + x^{-5})^3} dx$

$$= \int \frac{2x^{-3} + 5x^{-6}}{(1 + x^{-2} + x^{-5})^3} dx$$

Now, put $1 + x^{-2} + x^{-5} = t$

$$\Rightarrow (-2x^{-3} - 5x^{-6}) dx = dt$$

$$\Rightarrow (2x^{-3} + 5x^{-6}) dx = -dt$$

$$\therefore I = - \int \frac{dt}{t^3} = - \int t^{-3} dt$$

$$= - \frac{t^{-3+1}}{-3+1} + C = \frac{1}{2t^2} + C$$

$$= \frac{x^{10}}{2(x^5 + x^3 + 1)^2} + C$$

2. Let
$$I = \int \frac{\cos^3 x + \cos^5 x}{\sin^2 x + \sin^4 x} dx$$

$$= \int \frac{(\cos^2 x + \cos^4 x) \cdot \cos x}{(\sin^2 x + \sin^4 x)} dx$$

Put $\sin x = t \Rightarrow \cos x dx = dt$

$$\therefore I = \int \frac{[(1-t^2) + (1-t^2)^2]}{t^2 + t^4} dt$$

$$\Rightarrow I = \int \frac{1-t^2 + 1-2t^2 + t^4}{t^2 + t^4} dt$$

$$\Rightarrow I = \int \frac{2-3t^2 + t^4}{t^2(t^2+1)} dt \quad \dots(i)$$

Using partial fraction for

$$\frac{y^2 - 3y + 2}{y(y+1)} = 1 + \frac{A}{y} + \frac{B}{y+1} \quad [\text{where, } y = t^2]$$

$$\Rightarrow A = 2, B = -6$$

$$\therefore \frac{y^2 - 3y + 2}{y(y+1)} = 1 + \frac{2}{y} - \frac{6}{y+1}$$

Now, Eq. (i) reduces to,
$$I = \int \left(1 + \frac{2}{t^2} - \frac{6}{1+t^2} \right) dt$$

$$= t - \frac{2}{t} - 6 \tan^{-1}(t) + c$$

$$= \sin x - \frac{2}{\sin x} - 6 \tan^{-1}(\sin x) + c$$

3.
$$\frac{x^3 + 3x + 2}{(x^2 + 1)^2(x+1)} = \frac{x^3 + 2x + x + 2}{(x^2 + 1)^2(x+1)}$$

$$= \frac{x(x^2 + 1) + 2(x+1)}{(x^2 + 1)^2(x+1)}$$

$$= \frac{x}{(x^2 + 1)(x+1)} + \frac{2}{(x^2 + 1)^2}$$

Again,
$$\frac{x}{(x^2 + 1)(x+1)} = \frac{Ax+B}{(x^2 + 1)} + \frac{C}{(x+1)}$$

$$\Rightarrow x = (Ax+B)(x+1) + C(x^2+1)$$

On putting $x = -1$, we get

$$-1 = 2C \Rightarrow C = -1/2$$

On equating coefficients of x^2 , we get

$$0 = A + C$$

$$\Rightarrow A = -C = 1/2$$

On putting $x = 0$, we get

$$0 = B + C$$

$$\Rightarrow B = -C = 1/2$$

$$\frac{x^3 + 3x + 2}{(x^2 + 1)^2(x+1)} = \frac{x+1}{2(x^2+1)} - \frac{1}{2(x+1)} + \frac{2}{(x^2+1)^2}$$

$$\therefore I = \int \frac{x^3 + 3x + 2}{(x^2 + 1)^2(x+1)} dx$$

$$= -\frac{1}{2} \int \frac{dx}{x+1} + \frac{1}{2} \int \frac{x+1}{x^2+1} dx + 2 \int \frac{dx}{(x^2+1)^2}$$

$$\Rightarrow I = -\frac{1}{2} \log|x+1| + \frac{1}{4} \log|x^2+1|$$

$$+ \frac{1}{2} \tan^{-1} x + 2I_1 \quad \dots(i)$$

where,
$$I_1 = \int \frac{dx}{(x^2+1)^2}$$

Put $x = \tan \theta$

$$\Rightarrow dx = \sec^2 \theta d\theta$$

$$\therefore I_1 = \int \frac{\sec^2 \theta d\theta}{(\tan^2 \theta + 1)^2} = \int \cos^2 \theta d\theta = \frac{1}{2} \int (1 + \cos 2\theta) d\theta$$

$$= \frac{1}{2} \left[\theta + \frac{1}{2} \sin 2\theta \right]$$

$$= \frac{1}{2} \theta + \frac{1}{2} \cdot \frac{\tan \theta}{(1 + \tan^2 \theta)}$$

$$= \frac{1}{2} \tan^{-1} x + \frac{1}{2} \cdot \frac{x}{(1+x^2)}$$

From Eq. (i),

$$I = -\frac{1}{2} \log|x+1| + \frac{1}{4} \log|x^2+1| + \frac{3}{2} \tan^{-1} x + \frac{x}{x^2+1} + c$$

4. Let
$$I = \int \frac{(x+1)}{x(1+xe^x)^2} dx = \int \frac{e^x(x+1)}{xe^x(1+xe^x)^2} dx$$

Put $1 + xe^x = t \Rightarrow (e^x + xe^x) dx = dt$

$$\therefore I = \int \frac{dt}{(t-1)t^2} = \int \left[\frac{1}{t-1} - \frac{1}{t} - \frac{1}{t^2} \right] dt$$

$$= \log|t-1| - \log|t| + \frac{1}{t} + c$$

$$= \log \left| \frac{t-1}{t} \right| + \frac{1}{t} + c$$

$$= \log \left| \frac{xe^x}{1+xe^x} \right| + \frac{1}{1+xe^x} + c$$

12

Definite Integration

Topic 1 Properties of Definite Integral

Objective Questions I (Only one correct option)

1. $\int_{-\pi}^{\pi} |\pi - |x|| dx$ is equal to (2020 Main, 3 Sep I)
- (a) $\sqrt{2}\pi^2$ (b) $2\pi^2$
(c) π^2 (d) $\frac{\pi^2}{2}$

2. The integral $\int_{\pi/6}^{\pi/3} \tan^3 x \cdot \sin^2 3x (2 \sec^2 x \cdot \sin^2 3x + 3 \tan x \cdot \sin 6x) dx$ is equal to (2020 Main, 4 Sep II)
- (a) $-\frac{1}{9}$ (b) $\frac{7}{18}$ (c) $-\frac{1}{18}$ (d) $\frac{9}{2}$

3. A value of α such that $\int_{\alpha}^{\alpha+1} \frac{dx}{(x+\alpha)(x+\alpha+1)} = \log_e \left(\frac{9}{8}\right)$ is (2019 Main, 12 April II)
- (a) -2 (b) $\frac{1}{2}$ (c) $-\frac{1}{2}$ (d) 2

4. If $\int_0^{\pi/2} \frac{\cot x}{\cot x + \operatorname{cosec} x} dx = m(\pi + n)$, then $m \cdot n$ is equal to (2019 Main, 12 April I)
- (a) $-\frac{1}{2}$ (b) 1
(c) $\frac{1}{2}$ (d) -1

5. The integral $\int_{\pi/6}^{\pi/3} \sec^{2/3} x \operatorname{cosec}^{4/3} x dx$ is equal to (2019 Main, 10 April II)
- (a) $3^{5/6} - 3^{2/3}$ (b) $3^{7/6} - 3^{5/6}$
(c) $3^{5/3} - 3^{1/3}$ (d) $3^{4/3} - 3^{1/3}$

6. The value of $\int_0^{2\pi} [\sin 2x (1 + \cos 3x)] dx$, where $[t]$ denotes the greatest integer function, is (2019 Main, 10 April I)
- (a) $-\pi$ (b) 2π (c) -2π (d) π

7. The value of the integral $\int_0^1 x \cot^{-1}(1 - x^2 + x^4) dx$ is (2019 Main, 9 April III)
- (a) $\frac{\pi}{4} - \frac{1}{2} \log_e 2$ (b) $\frac{\pi}{2} - \frac{1}{2} \log_e 2$
(c) $\frac{\pi}{4} - \log_e 2$ (d) $\frac{\pi}{2} - \log_e 2$

8. The value of $\int_0^{\pi/2} \frac{\sin^3 x}{\sin x + \cos x} dx$ is (2019 Main, 9 April I)
- (a) $\frac{\pi-1}{2}$ (b) $\frac{\pi-2}{8}$ (c) $\frac{\pi-1}{4}$ (d) $\frac{\pi-2}{4}$

9. Let $f(x) = \int_0^x g(t) dt$, where g is a non-zero even function. If $f(x+5) = g(x)$, then $\int_0^x f(t) dt$ equals (2019 Main, 8 April II)
- (a) $5 \int_{x+5}^5 g(t) dt$ (b) $\int_5^{x+5} g(t) dt$ (c) $2 \int_5^{x+5} g(t) dt$ (d) $\int_{x+5}^5 g(t) dt$

10. If $f(x) = \frac{2 - x \cos x}{2 + x \cos x}$ and $g(x) = \log_e x$, ($x > 0$) then the value of the integral $\int_{-\pi/4}^{\pi/4} g(f(x)) dx$ is (2019 Main, 8 April I)
- (a) $\log_e 3$ (b) $\log_e e$
(c) $\log_e 2$ (d) $\log_e 1$

11. Let f and g be continuous functions on $[0, a]$ such that $f(x) = f(a-x)$ and $g(x) + g(a-x) = 4$, then $\int_0^a f(x) g(x) dx$ is equal to (2019 Main, 12 Jan I)
- (a) $4 \int_0^a f(x) dx$ (b) $\int_0^a f(x) dx$
(c) $2 \int_0^a f(x) dx$ (d) $-3 \int_0^a f(x) dx$

12. The integral $\int_1^e \left\{ \left(\frac{x}{e}\right)^{2x} - \left(\frac{e}{x}\right)^x \right\} \log_e x dx$ is equal to (2019 Main, 12 Jan II)
- (a) $\frac{3}{2} - e - \frac{1}{2e^2}$ (b) $-\frac{1}{2} + \frac{1}{e} - \frac{1}{2e^2}$
(c) $\frac{1}{2} - e - \frac{1}{e^2}$ (d) $\frac{3}{2} - \frac{1}{e} - \frac{1}{2e^2}$

13. The integral $\int_{\pi/6}^{\pi/4} \frac{dx}{\sin 2x (\tan^5 x + \cot^5 x)}$ equals (2019 Main, 11 Jan II)
- (a) $\frac{1}{5} \left(\frac{\pi}{4} - \tan^{-1} \left(\frac{1}{3\sqrt{3}} \right) \right)$ (b) $\frac{1}{20} \tan^{-1} \left(\frac{1}{9\sqrt{3}} \right)$
(c) $\frac{1}{10} \left(\frac{\pi}{4} - \tan^{-1} \left(\frac{1}{9\sqrt{3}} \right) \right)$ (d) $\frac{\pi}{40}$

14. The value of the integral $\int_{-2}^2 \frac{\sin^2 x}{\left[\frac{x}{\pi}\right] + \frac{1}{2}} dx$ (where, $[x]$ denotes the greatest integer less than or equal to x) is (2019 Main, 11 Jan I)
- (a) $4 - \sin 4$ (b) 4
(c) $\sin 4$ (d) 0
15. Let $I = \int_a^b (x^4 - 2x^2) dx$. If I is minimum, then the ordered pair (a, b) is (2019 Main, 10 Jan I)
- (a) $(-\sqrt{2}, 0)$ (b) $(0, \sqrt{2})$
(c) $(\sqrt{2}, -\sqrt{2})$ (d) $(-\sqrt{2}, \sqrt{2})$
16. If $\int_0^{\pi/3} \frac{\tan \theta}{\sqrt{2k \sec \theta}} d\theta = 1 - \frac{1}{\sqrt{2}}$, ($k > 0$), then the value of k is (2019 Main, 9 Jan II)
- (a) 1 (b) $\frac{1}{2}$
(c) 2 (d) 4
17. The value of $\int_0^{\pi} |\cos x|^3 dx$ is (2019 Main, 9 Jan I)
- (a) $\frac{2}{3}$ (b) $-\frac{4}{3}$ (c) 0 (d) $\frac{4}{3}$
18. The value of $\int_{-\pi/2}^{\pi/2} \frac{\sin^2 x}{1 + 2^x} dx$ is (2018 Main)
- (a) $\frac{\pi}{8}$ (b) $\frac{\pi}{2}$ (c) 4π (d) $\frac{\pi}{4}$
19. $\int_{\pi/4}^{3\pi/4} \frac{dx}{1 + \cos x}$ is equal to (2017 Main)
- (a) -2 (b) 2 (c) 4 (d) -1
20. The value of $\int_{-\pi/2}^{\pi/2} \frac{x^2 \cos x}{1 + e^x} dx$ is equal to (2016 Adv.)
- (a) $\frac{\pi^2}{4} - 2$ (b) $\frac{\pi^2}{4} + 2$
(c) $\pi^2 - e^{-\pi/2}$ (d) $\pi^2 + e^{\pi/2}$
21. The integral $\int_2^4 \frac{\log x^2}{\log x^2 + \log(36 - 12x + x^2)} dx$ is equal to (2015, Main)
- (a) 2 (b) 4 (c) 1 (d) 6
22. The integral $\int_{\pi/4}^{\pi/2} (2 \operatorname{cosec} x)^{17} dx$ is equal to (2014 Adv.)
- (a) $\int_0^{\log(1+\sqrt{2})} 2(e^u + e^{-u})^{16} du$
(b) $\int_0^{\log(1+\sqrt{2})} (e^u + e^{-u})^{17} du$
(c) $\int_0^{\log(1+\sqrt{2})} (e^u - e^{-u})^{17} du$
(d) $\int_0^{\log(1+\sqrt{2})} 2(e^u - e^{-u})^{16} du$
23. The integral $\int_0^{\pi} \sqrt{1 + 4 \sin^2 \frac{x}{2} - 4 \sin \frac{x}{2}} dx$ is equal to (2014 Main)
- (a) $\pi - 4$ (b) $\frac{2\pi}{3} - 4 - 4\sqrt{3}$
(c) $4\sqrt{3} - 4$ (d) $4\sqrt{3} - 4 - \pi/3$
24. The value of the integral $\int_{-\pi/2}^{\pi/2} \left(x^2 + \log \frac{\pi - x}{\pi + x}\right) \cos x dx$ is (2012)
- (a) 0 (b) $\frac{\pi^2}{2} - 4$ (c) $\frac{\pi^2}{2} + 4$ (d) $\frac{\pi^2}{2}$
25. The value of $\int_{\sqrt{\log 3}}^{\sqrt{\log 3}} \frac{x \sin x^2}{\sqrt{\log 2} \sin x^2 + \sin(\log 6 - x^2)} dx$ is (2011)
- (a) $\frac{1}{4} \log \frac{3}{2}$ (b) $\frac{1}{2} \log \frac{3}{2}$ (c) $\log \frac{3}{2}$ (d) $\frac{1}{6} \log \frac{3}{2}$
26. The value of $\int_{-2}^0 [x^3 + 3x^2 + 3x + 3 + (x + 1) \cos(x + 1)] dx$ is (2005, 1M)
- (a) 0 (b) 3 (c) 4 (d) 1
27. The value of the integral $\int_0^1 \sqrt{\frac{1-x}{1+x}} dx$ is (2004, 1M)
- (a) $\frac{\pi}{2} + 1$ (b) $\frac{\pi}{2} - 1$ (c) -1 (d) 1
28. The integral $\int_{-1/2}^{1/2} \left([x] + \log\left(\frac{1+x}{1-x}\right)\right) dx$ equals (2002, 1M)
- (a) $-\frac{1}{2}$ (b) 0 (c) 1 (d) $\log\left(\frac{1}{2}\right)$
29. The value of $\int_{-\pi}^{\pi} \frac{\cos^2 x}{1 + a^x} dx$, $a > 0$, is (2001, 1M)
- (a) π (b) $a\pi$
(c) $\frac{\pi}{2}$ (d) 2π
30. If $f(x) = \begin{cases} e^{\cos x} \sin x & , \text{ for } |x| \leq 2 \\ 2 & , \text{ otherwise} \end{cases}$ then $\int_{-2}^3 f(x) dx$ is equal to (2000, 2M)
- (a) 0 (b) 1 (c) 2 (d) 3
31. The value of the integral $\int_{e^{-1}}^{e^2} \left| \frac{\log_e x}{x} \right| dx$ is (2000, 2M)
- (a) $3/2$ (b) $5/2$ (c) 3 (d) 5
32. If for a real number y , $[y]$ is the greatest integer less than or equal to y , then the value of the integral $\int_{\pi/2}^{3\pi/2} [2 \sin x] dx$ is (1999, 2M)
- (a) $-\pi$ (b) 0
(c) $-\frac{\pi}{2}$ (d) $\frac{\pi}{2}$
33. $\int_{\pi/4}^{3\pi/4} \frac{dx}{1 + \cos x}$ is equal to (1999, 2M)
- (a) 2 (b) -2 (c) $\frac{1}{2}$ (d) $-\frac{1}{2}$
34. Let $f(x) = x - [x]$, for every real number x , where $[x]$ is the integral part of x . Then, $\int_{-1}^1 f(x) dx$ is (1998, 2M)
- (a) 1 (b) 2
(c) 0 (d) $-\frac{1}{2}$

296 Definite Integration

35. If $g(x) = \int_0^x \cos^4 t \, dt$, then $g(x + \pi)$ equals (1997, 2M)

- (a) $g(x) + g(\pi)$ (b) $g(x) - g(\pi)$
 (c) $g(x)g(\pi)$ (d) $\frac{g(x)}{g(\pi)}$

36. Let f be a positive function.

If $I_1 = \int_{1-k}^k x f[x(1-x)] \, dx$ and

$$I_2 = \int_{1-k}^k f[x(1-x)] \, dx, \text{ where } 2k - 1 > 0.$$

Then, $\frac{I_1}{I_2}$ is (1997C, 2M)

- (a) 2 (b) k
 (c) $1/2$ (d) 1

37. The value of $\int_0^{2\pi} [2 \sin x] \, dx$, where $[\cdot]$ represents the greatest integral functions, is (1995, 2M)

- (a) $-\frac{5\pi}{3}$ (b) $-\pi$ (c) $\frac{5\pi}{3}$ (d) -2π

38. If $f(x) = A \sin\left(\frac{\pi x}{2}\right) + B$,

$$f'\left(\frac{1}{2}\right) = \sqrt{2} \text{ and } \int_0^1 f(x) \, dx = \frac{2A}{\pi}, \text{ then constants}$$

A and B are (1995, 2M)

- (a) $\frac{\pi}{2}$ and $\frac{\pi}{2}$ (b) $\frac{2}{\pi}$ and $\frac{3}{\pi}$ (c) 0 and $-\frac{4}{\pi}$ (d) $\frac{4}{\pi}$ and 0

39. The value of $\int_0^{\pi/2} \frac{dx}{1 + \tan^3 x}$ is (1993, 1M)

- (a) 0 (b) 1
 (c) $\pi/2$ (d) $\pi/4$

40. Let $f: R \rightarrow R$ and $g: R \rightarrow R$ be continuous functions.

Then, the value of the integral

$$\int_{-\pi/2}^{\pi/2} [f(x) + f(-x)] [g(x) - g(-x)] \, dx \text{ is (1990, 2M)}$$

- (a) π (b) 1 (c) -1 (d) 0

41. For any integer n , the integral

$$\int_0^{\pi} e^{\cos^2 x} \cos^3(2n+1)x \, dx \text{ has the value (1985, 2M)}$$

- (a) π (b) 1
 (c) 0 (d) None of these

42. The value of the integral $\int_0^{\pi/2} \frac{\sqrt{\cot x}}{\sqrt{\cot x} + \sqrt{\tan x}} \, dx$ is

- (a) $\pi/4$ (b) $\pi/2$ (1983, 1M)
 (c) π (d) None of these

Assertion and Reason

43. **Statement I** The value of the integral (2013 Main)

$$\int_{\pi/6}^{\pi/3} \frac{dx}{1 + \sqrt{\tan x}} \text{ is equal to } \pi/6.$$

Statement II $\int_a^b f(x) \, dx = \int_a^b f(a+b-x) \, dx$

- (a) Statement I is correct; Statement II is correct; Statement II is a correct explanation for Statement I
 (b) Statement I is correct; Statement II is correct; Statement II is not a correct explanation for Statement I
 (c) Statement I is correct; Statement II is false
 (d) Statement I is incorrect; Statement II is correct

Passage Based Questions

Passage I

Let $F: R \rightarrow R$ be a thrice differentiable function. Suppose that $F(1) = 0$, $F(3) = -4$ and $F'(x) < 0$ for all $x \in (1, 3)$. Let $f(x) = xF(x)$ for all $x \in R$. (2015 Adv.)

44. The correct statement(s) is/are

- (a) $f'(1) < 0$ (b) $f(2) < 0$
 (c) $f'(x) \neq 0$ for any $x \in (1, 3)$ (d) $f'(x) = 0$ for some $x \in (1, 3)$

45. If $\int_1^3 x^2 F'(x) \, dx = -12$ and $\int_1^3 x^3 F''(x) \, dx = 40$, then the correct expression(s) is/are

- (a) $9f'(3) + f'(1) - 32 = 0$ (b) $\int_1^3 f(x) \, dx = 12$
 (c) $9f'(3) - f'(1) + 32 = 0$ (d) $\int_1^3 f(x) \, dx = -12$

Passage II

For every function $f(x)$ which is twice differentiable, these will be good approximation of

$$\int_a^b f(x) \, dx = \left(\frac{b-a}{2}\right) \{f(a) + f(b)\},$$

for more accurate results for $c \in (a, b)$,

$$F(c) = \frac{c-a}{2} [f(a) - f(c)] + \frac{b-c}{2} [f(b) - f(c)]$$

$$\text{When } c = \frac{a+b}{2}$$

$$\int_a^b f(x) \, dx = \frac{b-a}{4} \{f(a) + f(b) + 2f(c)\} \, dx \quad (2006, 6M)$$

46. If $\lim_{t \rightarrow a} \frac{\int_a^t f(x) \, dx - \frac{(t-a)}{2} \{f(t) + f(a)\}}{(t-a)^3} = 0$,

then degree of polynomial function $f(x)$ at most is

- (a) 0 (b) 1
 (c) 3 (d) 2

47. If $f''(x) < 0, \forall x \in (a, b)$, and $(c, f(c))$ is point of maxima, where $c \in (a, b)$, then $f'(c)$ is

- (a) $\frac{f(b) - f(a)}{b-a}$ (b) $3 \left[\frac{f(b) - f(a)}{b-a} \right]$
 (c) $2 \left[\frac{f(b) - f(a)}{b-a} \right]$ (d) 0

48. Good approximation of $\int_0^{\pi/2} \sin x \, dx$, is

- (a) $\pi/4$ (b) $\pi(\sqrt{2} + 1)/4$
 (c) $\pi(\sqrt{2} + 1)/8$ (d) $\frac{\pi}{8}$

Objective Questions II

(One or more than one correct option)

49. Let $f : R \rightarrow (0, 1)$ be a continuous function. Then, which of the following function(s) has (have) the value zero at some point in the interval $(0, 1)$? (2017 Adv.)

- (a) $e^x - \int_0^x f(t) \sin t \, dt$ (b) $f(x) + \int_0^{\frac{\pi}{2}} f(t) \sin t \, dt$
 (c) $x - \int_0^{\frac{\pi}{2}-x} f(t) \cos t \, dt$ (d) $x^9 - f(x)$

50. If $I = \sum_{k=1}^{98} \int_k^{k+1} \frac{k+1}{x(x+1)} \, dx$, then (2017 Adv.)

- (a) $I > \log_e 99$ (b) $I < \log_e 99$
 (c) $I < \frac{49}{50}$ (d) $I > \frac{49}{50}$

51. Let $f(x) = 7 \tan^8 x + 7 \tan^6 x - 3 \tan^4 x - 3 \tan^2 x$ for all $x \in \left(-\frac{\pi}{2}, \frac{\pi}{2}\right)$. Then, the correct expression(s) is/are

- (a) $\int_0^{\pi/4} xf(x) \, dx = \frac{1}{12}$ (b) $\int_0^{\pi/4} f(x) \, dx = 0$ (2015 Adv.)
 (c) $\int_0^{\pi/4} xf(x) \, dx = \frac{1}{6}$ (d) $\int_0^{\pi/4} f(x) \, dx = 1$

52. Let $f'(x) = \frac{192x^3}{2 + \sin^4 \pi x}$ for all $x \in R$ with $f\left(\frac{1}{2}\right) = 0$. If

$m \leq \int_{1/2}^1 f(x) \, dx \leq M$, then the possible values of m and M are (2015 Adv.)

- (a) $m = 13, M = 24$
 (b) $m = \frac{1}{4}, M = \frac{1}{2}$
 (c) $m = -11, M = 0$
 (d) $m = 1, M = 12$

53. The option(s) with the values of a and L that satisfy the equation $\frac{\int_0^{4\pi} e^t (\sin^6 at + \cos^4 at) dt}{\int_0^{\pi} e^t (\sin^6 at + \cos^4 at) dt} = L$, is/are (2015 Adv.)

- (a) $a = 2, L = \frac{e^{4\pi} - 1}{e^{\pi} - 1}$ (b) $a = 2, L = \frac{e^{4\pi} + 1}{e^{\pi} + 1}$
 (c) $a = 4, L = \frac{e^{4\pi} - 1}{e^{\pi} - 1}$ (d) $a = 4, L = \frac{e^{4\pi} + 1}{e^{\pi} + 1}$

54. The value(s) of $\int_0^1 \frac{x^4(1-x)^4}{1+x^2} \, dx$ is (are) (2010)

- (a) $\frac{22}{7} - \pi$ (b) $\frac{2}{105}$ (c) 0 (d) $\frac{71}{15} - \frac{3\pi}{2}$

55. If $I_n = \int_{-\pi}^{\pi} \frac{\sin nx}{(1 + \pi^x) \sin x} \, dx, n = 0, 1, 2, \dots$, then (2009)

- (a) $I_n = I_{n+2}$ (b) $\sum_{m=1}^{10} I_{2m+1} = 10\pi$
 (c) $\sum_{m=1}^{10} I_{2m} = 0$ (d) $I_n = I_{n+1}$

Integer & Numerical Answer Type Questions

56. Let $[t]$ denote the greatest integer less than or equal to t . Then the value of $\int_1^2 [2x - [3x]] \, dx$ is (2020 Main, 2 Sep II)

57. The value of the integral $\int_0^{\pi/2} \frac{3\sqrt{\cos \theta}}{(\sqrt{\cos \theta} + \sqrt{\sin \theta})^5} \, d\theta$ equals (2019 Adv.)

58. If $I = \frac{2}{\pi} \int_{-\pi/4}^{\pi/4} \frac{dx}{(1 + e^{\sin x})(2 - \cos 2x)}$ then $27I^2$ equals (2019 Adv.)

59. The value of the integral $\int_0^{1/2} \frac{1 + \sqrt{3}}{((x+1)^2(1-x)^6)^{1/4}} \, dx$ is (2018 Adv.)

60. Let $f : R \rightarrow R$ be a function defined by $f(x) = \begin{cases} [x], & x \leq 2 \\ 0, & x > 2 \end{cases}$ where $[x]$ denotes the greatest integer less than or equal to x . If $I = \int_{-1}^2 \frac{xf(x^2)}{2 + f(x+1)} \, dx$, then the value of $(4I - 1)$ is (2015 Adv.)

61. If $\alpha = \int_0^1 (e^{9x + 3 \tan^{-1} x}) \left(\frac{12 + 9x^2}{1 + x^2} \right) \, dx$, where $\tan^{-1} x$ takes only principal values, then the value of $\left(\log_e |1 + \alpha| - \frac{3\pi}{4} \right)$ is (2015 Adv.)

62. The value of $\int_0^1 4x^3 \left\{ \frac{d^2}{dx^2} (1 - x^2)^5 \right\} \, dx$ is (2014 Adv.)

Fill in the Blanks

63. Let $f : [1, \infty) \rightarrow [2, \infty)$ be differentiable function such that $f(1) = 2$. If $6 \int_1^x f(t) \, dt = 3x f(x) - x^3, \forall x \geq 1$ then the value of $f(2)$ is (2011)

64. Let $\frac{d}{dx} F(x) = \frac{e^{\sin x}}{x}, x > 0$. If $\int_1^4 \frac{2e^{\sin x^2}}{x} \, dx = F(k) - F(1)$, then one of the possible values of k is (1997, 2M)

65. The value of $\int_1^{37\pi} \frac{\pi \sin(\pi \log x)}{x} \, dx$ is (1997, 2M)

66. For $n > 0, \int_0^{2\pi} \frac{x \sin^{2n} x}{\sin^{2n} x + \cos^{2n} x} \, dx = \dots\dots$ (1996, 2M)

67. If for non-zero $x, af(x) + bf\left(\frac{1}{x}\right) = \frac{1}{x} - 5$, where $a \neq b$, then $\int_1^2 f(x) \, dx = \dots\dots$ (1996, 2M)

68. The value of $\int_2^3 \frac{\sqrt{x}}{\sqrt{5-x} + \sqrt{x}} \, dx$ is (1994, 2M)

298 Definite Integration

69. The value of $\int_{\pi/4}^{3\pi/4} \frac{x}{1 + \sin x} dx \dots\dots$ (1993, 2M)
70. The value of $\int_{-2}^2 |1 - x^2| dx$ is ... (1989, 2M)
71. The integral $\int_0^{1.5} [x^2] dx$, where $[.]$ denotes the greatest function, equals (1988, 2M)

Match the Columns

72. Match the conditions/expressions in Column I with statement in Column II.

Column I	Column II
A. $\int_{-1}^1 \frac{dx}{1+x^2}$	P. $\frac{1}{2} \log\left(\frac{2}{3}\right)$
B. $\int_0^1 \frac{dx}{\sqrt{1-x^2}}$	Q. $2 \log\left(\frac{2}{3}\right)$
C. $\int_2^3 \frac{dx}{1-x^2}$	R. $\frac{\pi}{3}$
D. $\int_1^2 \frac{dx}{x\sqrt{x^2-1}}$	S. $\frac{\pi}{2}$

73. Match List I with List II and select the correct answer using codes given below the lists. (2014)

List I	List II
P. The number of polynomials $f(x)$ with non-negative integer coefficients of degree ≤ 2 , satisfying $f(0) = 0$ and $\int_0^1 f(x) dx = 1$, is	(i) 8
Q. The number of points in the interval $[-\sqrt{13}, \sqrt{13}]$ at which $f(x) = \sin(x^2) + \cos(x^2)$ attains its maximum value, is	(ii) 2
R. $\int_{-2}^2 \frac{3x^2}{1+e^x} dx$ equals	(iii) 4
S. $\left(\int_{-1/2}^{1/2} \cos 2x \log\left(\frac{1+x}{1-x}\right) dx \right) / \left(\int_0^{1/2} \cos 2x \log\left(\frac{1+x}{1-x}\right) dx \right)$ equals	(iv) 0

Codes

- P Q R S
 (a) (iii) (ii) (iv) (i)
 (b) (ii) (iii) (iv) (i)
 (c) (iii) (ii) (i) (iv)
 (d) (ii) (iii) (i) (iv)

Analytical & Descriptive Questions

74. The value of $\frac{(5050) \int_0^1 (1-x^{50})^{100} dx}{\int_0^1 (1-x^{50})^{101} dx}$ is (2006, 6M)
75. Evaluate $\int_0^\pi e^{|\cos x|} \left[2 \sin\left(\frac{1}{2} \cos x\right) + 3 \cos\left(\frac{1}{2} \cos x\right) \right] \sin x dx$. (2005, 2M)

76. Evaluate $\int_{-\pi/3}^{\pi/3} \frac{\pi + 4x^3}{2 - \cos\left(|x| + \frac{\pi}{3}\right)} dx$. (2004, 4M)
77. If f is an even function, then prove that $\int_0^{\pi/2} f(\cos 2x) \cos x dx = \sqrt{2} \int_0^{\pi/4} f(\sin 2x) \cos x dx$. (2003, 2M)

78. Evaluate $\int_0^\pi \frac{e^{\cos x}}{e^{\cos x} + e^{-\cos x}} dx$. (1999, 3M)

79. Prove that $\int_0^1 \tan^{-1}\left(\frac{1}{1-x+x^2}\right) dx = 2 \int_0^1 \tan^{-1} x dx$.
 Hence or otherwise, evaluate the integral $\int_0^1 \tan^{-1}(1-x+x^2) dx$. (1998, 8M)

80. Integrate $\int_0^{\pi/4} \log(1 + \tan x) dx$. (1997C, 2M)

81. Determine the value of $\int_{-\pi}^\pi \frac{2x(1 + \sin x)}{1 + \cos^2 x} dx$. (1995, 5M)

82. Evaluate the definite integral $\int_{-1/\sqrt{3}}^{1/\sqrt{3}} \left(\frac{x^4}{1-x^4} \right) \cos^{-1}\left(\frac{2x}{1+x^2}\right) dx$. (1995, 5M)

83. Evaluate $\int_2^3 \frac{2x^5 + x^4 - 2x^3 + 2x^2 + 1}{(x^2 + 1)(x^4 - 1)} dx$. (1993, 5M)

84. A cubic $f(x)$ vanishes at $x = -2$ and has relative minimum / maximum at $x = -1$ and $x = 1/3$.
 If $\int_{-1}^1 f(x) dx = 14/3$, find the cubic $f(x)$. (1992, 4M)

85. Evaluate $\int_0^\pi \frac{x \sin(2x) \sin\left(\frac{\pi}{2} \cos x\right)}{2x - \pi} dx$. (1991, 4M)

86. Show that, $\int_0^{\pi/2} f(\sin 2x) \sin x dx = \sqrt{2} \int_0^{\pi/4} f(\cos 2x) \cos x dx$. (1990, 4M)

87. Prove that for any positive integer k , $\frac{\sin 2kx}{\sin x} = 2 [\cos x + \cos 3x + \dots + \cos(2k-1)x]$
 Hence, prove that $\int_0^{\pi/2} \sin 2kx \cdot \cot x dx = \pi/2$. (1990, 4M)

88. If f and g are continuous functions on $[0, a]$ satisfying $f(x) = f(a-x)$ and $g(x) + g(a-x) = 2$, then show that $\int_0^a f(x)g(x) dx = \int_0^a f(x) dx$. (1989, 4M)

89. Prove that the value of the integral, $\int_0^{2a} [f(x) / \{f(x) + f(2a-x)\}] dx$ is equal to a . (1988, 4M)

90. Evaluate $\int_0^1 \log[\sqrt{1-x} + \sqrt{1+x}] dx$. (1988, 5M)

91. Evaluate $\int_0^\pi \frac{x dx}{1 + \cos \alpha \sin x}$, $0 < \alpha < \pi$. (1986, 2 $\frac{1}{2}$ M)

92. Evaluate $\int_0^{\pi/2} \frac{x \sin x \cos x}{\cos^4 x + \sin^4 x} dx$. (1985, 2 $\frac{1}{2}$ M)
93. Evaluate $\int_0^{1/2} \frac{x \sin^{-1} x}{\sqrt{1-x^2}} dx$. (1984, 2M)
94. Evaluate $\int_0^{\pi/4} \frac{\sin x + \cos x}{9 + 16 \sin 2x} dx$. (1983, 3M)
95. (i) Show that $\int_0^{\pi} x f(\sin x) dx = \frac{\pi}{2} \int_0^{\pi} f(\sin x) dx$. (1982, 2M)

(ii) Find the value of $\int_{-1}^{3/2} |x \sin \pi x| dx$. (1982, 3M)

96. Evaluate $\int_0^1 (tx + 1 - x)^n dx$, where n is a positive integer and t is a parameter independent of x . Hence, show that $\int_0^1 x^k (1-x)^{n-k} dx = \frac{1}{nC_k(n+1)}$, for $k=0, 1, \dots, n$. (1981, 4M)

Topic 2 Periodicity of Integral Functions

Objective Questions I (Only one correct option)

1. The value of $\int_{-\pi/2}^{\pi/2} \frac{dx}{[x] + [\sin x] + 4}$, where $[t]$ denotes the greatest integer less than or equal to t , is (2019 Main, 10 Jan II)
- (a) $\frac{1}{12} (7\pi - 5)$ (b) $\frac{1}{12} (7\pi + 5)$
- (c) $\frac{3}{10} (4\pi - 3)$ (d) $\frac{3}{20} (4\pi - 3)$
2. Let $T > 0$ be a fixed real number. Suppose, f is a continuous function such that for all $x \in R$, $f(x + T) = f(x)$. If $I = \int_0^T f(x) dx$, then the value of $\int_3^{3+3T} f(2x) dx$ is (2002, 1M)
- (a) $\frac{3}{2} I$ (b) I
- (c) $3I$ (d) $6I$
3. Let $g(x) = \int_0^x f(t) dt$, where f is such that $\frac{1}{2} \leq f(t) \leq 1$ for $t \in [0, 1]$ and $0 \leq f(t) \leq \frac{1}{2}$ for $t \in [1, 2]$. Then, $g(2)$ satisfies the inequality (2000, 2M)
- (a) $-\frac{3}{2} \leq g(2) < \frac{1}{2}$ (b) $0 \leq g(2) < 2$

(c) $\frac{3}{2} < g(2) \leq 5/2$ (d) $2 < g(2) < 4$

Analytical & Descriptive Questions

4. Show that $\int_0^{n\pi+v} |\sin x| dx = 2n + 1 - \cos v$, where n is a positive integer and $0 \leq v < \pi$. (1994, 4M)
5. Given a function $f(x)$ such that it is integrable over every interval on the real line and $f(t+x) = f(x)$, for every x and a real t , then show that the integral $\int_a^{a+t} f(x) dx$ is independent of a . (1984, 4M)

Integer & Numerical Answer Type Question

6. For any real number x , let $[x]$ denotes the largest integer less than or equal to x . Let f be a real valued function defined on the interval $[-10, 10]$ by
- $$f(x) = \begin{cases} x - [x], & \text{if } f(x) \text{ is odd} \\ 1 + [x] - x, & \text{if } f(x) \text{ is even} \end{cases}$$
- Then, the value of $\frac{\pi^2}{10} \int_{-10}^{10} f(x) \cos \pi x dx$ is..... (2010)

Topic 3 Estimation, Gamma Function and Derivative of Definite Integration

Objective Questions I (Only one correct option)

1. If $\int_0^x f(t) dt = x^2 + \int_x^1 t^2 f(t) dt$, then $f\left(\frac{1}{2}\right)$ is (2019 Main, 10 Jan II)
- (a) $\frac{24}{25}$ (b) $\frac{18}{25}$
- (c) $\frac{6}{25}$ (d) $\frac{4}{5}$
2. Let $f: [0, 2] \rightarrow R$ be a function which is continuous on $[0, 2]$ and is differentiable on $(0, 2)$ with $f(0) = 1$.

Let $F(x) = \int_0^{x^2} f(\sqrt{t}) dt$, for $x \in [0, 2]$. If $F'(x) = f'(x)$, $\forall x \in (0, 2)$, then $F(2)$ equals (2014 Adv.)

- (a) $e^2 - 1$ (b) $e^4 - 1$
- (c) $e - 1$ (d) e^4
3. The intercepts on X -axis made by tangents to the curve, $y = \int_0^x |t| dt$, $x \in R$, which are parallel to the line $y = 2x$, are equal to (2013 Main)
- (a) ± 1 (b) ± 2
- (c) ± 3 (d) ± 4

300 Definite Integration

4. Let f be a non-negative function defined on the interval $[0, 1]$. If $\int_0^x \sqrt{1 - (f'(t))^2} dt = \int_0^x f(t) dt$, $0 \leq x \leq 1$ and $f(0) = 0$, then (2009)

(a) $f\left(\frac{1}{2}\right) < \frac{1}{2}$ and $f\left(\frac{1}{3}\right) > \frac{1}{3}$

(b) $f\left(\frac{1}{2}\right) > \frac{1}{2}$ and $f\left(\frac{1}{3}\right) > \frac{1}{3}$

(c) $f\left(\frac{1}{2}\right) < \frac{1}{2}$ and $f\left(\frac{1}{3}\right) < \frac{1}{3}$

(d) $f\left(\frac{1}{2}\right) > \frac{1}{2}$ and $f\left(\frac{1}{3}\right) < \frac{1}{3}$

5. If $\int_{\sin x}^1 t^2 f(t) dt = 1 - \sin x$, $\forall x \in (0, \pi/2)$, then $f\left(\frac{1}{\sqrt{3}}\right)$ is

- (a) 3 (b) $\sqrt{3}$ (2005, 1M)
 (c) $1/3$ (d) None of these

6. If $f(x)$ is differentiable and $\int_0^{t^2} x f(x) dx = \frac{2}{5} t^5$, then

$f\left(\frac{4}{25}\right)$ equals (2004, 1M)

(a) $\frac{2}{5}$ (b) $-\frac{5}{2}$

(c) 1 (d) $\frac{5}{2}$

7. If $f(x) = \int_{x^2}^{x^2+1} e^{-t^2} dt$, then $f(x)$ increases in (2003, 1M)

- (a) (2, 2) (b) no value of x
 (c) (0, ∞) (d) $(-\infty, 0)$

8. If $I(m, n) = \int_0^1 t^m (1+t)^n dt$, then the expression for $I(m, n)$ in terms of $I(m+1, n-1)$ is (2003, 1M)

(a) $\frac{2^n}{m+1} - \frac{n}{m+1} I(m+1, n-1)$

(b) $\frac{n}{m+1} I(m+1, n-1)$

(c) $\frac{2^n}{m+1} + \frac{n}{m+1} I(m+1, n-1)$

(d) $\frac{m}{m+1} I(m+1, n-1)$

9. Let $f(x) = \int_1^x \sqrt{2-t^2} dt$. Then, the real roots of the equation $x^2 - f'(x) = 0$ are (2002, 1M)

(a) ± 1 (b) $\pm \frac{1}{\sqrt{2}}$

(c) $\pm \frac{1}{2}$ (d) 0 and 1

10. Let $f: (0, \infty) \rightarrow R$ and $F(x) = \int_0^x f(t) dt$. If $F(x^2) = x^2(1+x)$, then $f(4)$ equals (2001, 1M)

(a) $\frac{5}{4}$ (b) 7 (c) 4 (d) 2

11. $\int_0^x f(t) dt = x + \int_x^1 t f(t) dt$, then the value of $f(1)$ is (1998, 2M)

- (a) $\frac{1}{2}$ (b) 0
 (c) 1 (d) $-\frac{1}{2}$

12. Let $f: R \rightarrow R$ be a differentiable function and $f(1) = 4$. Then, the value of $\lim_{x \rightarrow 1} \int_4^{f(x)} \frac{2t}{x-1} dt$ is (1990, 2M)

- (a) $8f'(1)$ (b) $4f'(1)$
 (c) $2f'(1)$ (d) $f'(1)$

13. The value of the definite integral $\int_0^1 (1 + e^{-x^2}) dx$ is (1981, 2M)

- (a) -1
 (b) 2
 (c) $1 + e^{-1}$
 (d) None of the above

Objective Question II

(One or more than one correct option)

14. Which of the following inequalities is/are TRUE? (2020 Adv.)

- (a) $\int_0^1 x \cos x dx \geq \frac{3}{8}$ (b) $\int_0^1 x \sin x dx \geq \frac{3}{10}$
 (c) $\int_0^1 x^2 \cos x dx \geq \frac{1}{2}$ (d) $\int_0^1 x^2 \sin x dx \geq \frac{2}{9}$

15. If $g(x) = \int_{\sin x}^{\sin(2x)} \sin^{-1}(t) dt$, then (2017 Adv.)

- (a) $g'\left(-\frac{\pi}{2}\right) = 2\pi$ (b) $g'\left(-\frac{\pi}{2}\right) = -2\pi$
 (c) $g'\left(\frac{\pi}{2}\right) = 2\pi$ (d) $g'\left(\frac{\pi}{2}\right) = -2\pi$

Passage Based Questions

Let $f(x) = (1-x)^2 \sin^2 x + x^2$, $\forall x \in R$ and $g(x) = \int_1^x \left(\frac{2(t-1)}{t+1} - \ln t \right) f(t) dt$, $\forall x \in (1, \infty)$.

16. Consider the statements

P : There exists some $x \in R$ such that, $f(x) + 2x = 2(1+x^2)$.

Q : There exists some $x \in R$ such that, $2f(x) + 1 = 2x(1+x)$.

Then,

- (a) both P and Q are true
 (b) P is true and Q is false
 (c) P is false and Q is true
 (d) both P and Q are false

17. Which of the following is true?

- (a) g is increasing on $(1, \infty)$
 (b) g is decreasing on $(1, \infty)$
 (c) g is increasing on $(1, 2)$ and decreasing on $(2, \infty)$
 (d) g is decreasing on $(1, 2)$ and increasing on $(2, \infty)$

Fill in the Blank

18. $f(x) = \begin{vmatrix} \sec x & \cos x & \sec^2 x + \cot x \operatorname{cosec} x \\ \cos^2 x & \cos^2 x & \operatorname{cosec}^2 x \\ 1 & \cos^2 x & \cos^2 x \end{vmatrix}$.

Then, $\int_0^{\pi/2} f(x) dx = \dots$. (1987, 2M)

Analytical & Descriptive Questions

19. For $x > 0$, let $f(x) = \int_1^x \frac{\ln t}{1+t} dt$. Find the function $f(x) + f(1/x)$ and show that $f(e) + f(1/e) = 1/2$, where $\ln t = \log_e t$. (2000, 5M)

20. Let $a + b = 4$, where $a < 2$ and let $g(x)$ be a differentiable function. If $\frac{dg}{dx} > 0, \forall x$ prove that $\int_0^a g(x) dx + \int_0^b g(x) dx$ increases as $(b - a)$ increases. (1997, 5M)

21. Determine a positive integer $n \leq 5$, such that $\int_0^1 e^x (x-1)^n dx = 16 - 6e$ (1992, 4M)

22. If 'f' is a continuous function with $\int_0^x f(t) dt \rightarrow \infty$ as $|x| \rightarrow \infty$, then show that every line $y = mx$ intersects the curve $y^2 + \int_0^x f(t) dt = 2$ (1991, 2M)

23. Investigate for maxima and minima the function, $f(x) = \int_1^x [2(t-1)(t-2)^3 + 3(t-1)^2(t-2)^2] dt$. (1988, 5M)

Integer & Numerical Answer Type Question

24. Let $f: R \rightarrow R$ be a differentiable function such that its derivative f' is continuous and $f(\pi) = -6$.

If $F: [0, \pi] \rightarrow R$ is defined by $F(x) = \int_0^x f(t) dt$, and if

$$\int_0^\pi (f'(x) + F(x)) \cos x dx = 2$$

then the value of $f(0)$ is (2020 Adv.)

Topic 4 Limits as the Sum

Objective Question I (Only one correct option)

1. $\lim_{n \rightarrow \infty} \left(\frac{(n+1)^{1/3}}{n^{4/3}} + \frac{(n+2)^{1/3}}{n^{4/3}} + \dots + \frac{(2n)^{1/3}}{n^{4/3}} \right)$ is equal to (2019 Main, 10 April I)

- (a) $\frac{4}{3}(2)^{4/3}$ (b) $\frac{3}{4}(2)^{4/3} - \frac{4}{3}$
- (c) $\frac{3}{4}(2)^{4/3} - \frac{3}{4}$ (d) $\frac{4}{3}(2)^{3/4}$

2. $\lim_{n \rightarrow \infty} \left(\frac{n}{n^2+1^2} + \frac{n}{n^2+2^2} + \frac{n}{n^2+3^2} + \dots + \frac{1}{5n} \right)$ is equal to (2019 Main, 12 Jan II)

- (a) $\tan^{-1}(3)$
- (b) $\tan^{-1}(2)$
- (c) $\pi/4$
- (d) $\pi/2$

3. $\lim_{n \rightarrow \infty} \left(\frac{(n+1)(n+2)\dots 3n}{n^{2n}} \right)^{1/n}$ is equal to (2016 Main)

- (a) $\frac{18}{e^4}$
- (b) $\frac{27}{e^2}$
- (c) $\frac{9}{e^2}$
- (d) $3 \log 3 - 2$

Objective Questions II

(One or more than one correct option)

4. For $a \in R, |a| > 1$, let

$$\lim_{n \rightarrow \infty} \left[\frac{1 + \sqrt[3]{2} + \dots + \sqrt[3]{n}}{n^{7/3} \left(\frac{1}{(an+1)^2} + \frac{1}{(an+2)^2} + \dots + \frac{1}{(an+n)^2} \right)} \right] = 54$$

Then the possible value(s) of a is/are (2020 Adv.)
 (a) -6 (b) 7 (c) 8 (d) -9

5. For $a \in R$ (the set of all real numbers), $a \neq -1$,

$$\lim_{n \rightarrow \infty} \frac{(1^a + 2^a + \dots + n^a)}{(n+1)^{a-1} [(na+1) + (na+2) + \dots + (na+n)]} = \frac{1}{60}$$

Then, a is equal to

- (a) 5 (b) 7 (c) $\frac{-15}{2}$ (d) $\frac{-17}{2}$

6. Let $S_n = \sum_{k=0}^n \frac{n}{n^2 + kn + k^2}$ and $T_n = \sum_{k=0}^{n-1} \frac{n}{n^2 + kn + k^2}$, for

$n = 1, 2, 3, \dots$, then (2008, 4M)

- (a) $S_n < \frac{\pi}{3\sqrt{3}}$ (b) $S_n > \frac{\pi}{3\sqrt{3}}$ (c) $T_n < \frac{\pi}{3\sqrt{3}}$ (d) $T_n > \frac{\pi}{3\sqrt{3}}$

Analytical & Descriptive Question

7. Show that, $\lim_{n \rightarrow \infty} \left(\frac{1}{n+1} + \frac{1}{n+2} + \dots + \frac{1}{6n} \right) = \log 6$. (1981, 2M)

Answers

Topic 1

1. (c) 2. (c) 3. (a) 4. (d)
 5. (b) 6. (a) 7. (a) 8. (c)
 9. (d) 10. (d) 11. (c) 12. (a)
 13. (c) 14. (d) 15. (d) 16. (c)
 17. (d) 18. (d) 19. (b) 20. (a)
 21. (c) 22. (a) 23. (d) 24. (b)
 25. (a) 26. (c) 27. (b) 28. (a)
 29. (c) 30. (c) 31. (b) 32. (c)
 33. (a) 34. (a) 35. (a) 36. (c)
 37. (a) 38. (d) 39. (d) 40. (d)
 41. (c) 42. (a) 43. (d) 44. (a, b, c)
 45. (c, d) 46. (b) 47. (a) 48. (c)
 49. (c, d) 50. (b, d) 51. (a, b) 52. (*)
 53. (a, c) 54. (a) 55. (a, b, c) 56. (1)
 57. (0.5) 58. (4.00) 59. (2) 60. (0)
 61. (9) 62. (2) 63. (8/3) 64. ($k = 16$)
 65. (2) 66. π^2 67. $\frac{1}{a^2 - b^2} \left[a \log 2 - 5a + \frac{7}{2}b \right]$
 68. $\left(\frac{1}{2}\right)$ 69. $\pi(\sqrt{2} - 1)$ 70. (4) 71. $(2 - \sqrt{2})$
 72. $A \rightarrow S; B \rightarrow S; C \rightarrow P; D \rightarrow R$ 73. (d)
 74. 5051 75. $\frac{24}{5} \left[e \cos\left(\frac{1}{2}\right) + \frac{e}{2} \sin\left(\frac{1}{2}\right) - 1 \right]$
 76. $\left[\frac{4\pi}{\sqrt{3}} \tan^{-1}\left(\frac{1}{2}\right) \right]$ 78. $\frac{\pi}{2}$ 79. $\log 2$

80. $\frac{\pi}{8} (\log 2)$ 81. π^2 82. $\frac{\pi}{12} [\pi + 3 \log(2 + \sqrt{3}) - 4\sqrt{3}]$
 83. $\frac{1}{2} \log 6 - \frac{1}{10}$ 84. $f(x) = x^3 + x^2 - x + 2$ 85. $\frac{8}{\pi^2}$
 90. $\frac{1}{2} \log 2 - \frac{1}{2} + \frac{\pi}{4}$ 91. $\frac{\alpha\pi}{\sin\alpha}$ 92. $\frac{\pi^2}{16}$
 93. $\left(-\frac{\sqrt{3}}{12} \pi + \frac{1}{2}\right)$ 94. $\left[\frac{1}{20}(\log 3)\right]$ 95. (ii) $\left[\frac{3\pi + 1}{\pi^2}\right]$

Topic 2

1. (d) 2. (c) 3. (b) 6. (4)

Topic 3

1. (a) 2. (b) 3. (a) 4. (c)
 5. (a) 6. (a) 7. (d) 8. (a)
 9. (a) 10. (c) 11. (a) 12. (a)
 13. (d) 14. (a,b,d) 15. (*) 16. (c)
 17. (b) 18. $-\left(\frac{15\pi + 32}{60}\right)$ 19. $\frac{1}{2}$

21. ($n = 3$)

23. At $x = 1$ and $\frac{7}{5}$, $f(x)$ is maximum and minimum respectively.

24. (4)

Topic 4

1. (c) 2. (b) 3. (b) 4. (c,d)
 5. (b, d) 6. (a, d)

Hints & Solutions

Topic 1 Properties of Definite Integral

1. Given integral $\int_{-\pi}^{\pi} |\pi - |x|| dx$
 $= 2 \int_0^{\pi} |\pi - |x|| dx = 2 \int_0^{\pi} |\pi - x| dx$
 $= 2 \int_0^{\pi} (\pi - x) dx$ $[\because x \in (0, \pi)]$
 $= 2 \left[\pi x - \frac{x^2}{2} \right]_0^{\pi} = 2 \left[\pi^2 - \frac{\pi^2}{2} \right] = 2 \left(\frac{\pi^2}{2} \right) = \pi^2$

Hence, option (c) is correct.

2. Given integral

$$I = \int_{\pi/6}^{\pi/3} \tan^3 x \cdot \sin^2 3x (2 \sec^2 x \sin^2 3x + 3 \tan x \cdot \sin 6x) dx$$

$$= \int_{\pi/6}^{\pi/3} [2 \tan^3 x \sec^2 x \sin^4 3x + 3 \tan^4 x (2 \sin^3 3x \cos 3x)] dx$$

$$= \int_{\pi/6}^{\pi/3} \left[\frac{d}{dx} \left(\frac{\tan^4 x \sin^4 3x}{2} \right) \right] dx$$

$$= \left[\frac{1}{2} \tan^4 x \sin^4 3x \right]_{\pi/6}^{\pi/3}$$

$$= \frac{1}{2} \left[(9 \times 0) - \left(\frac{1}{9} \times 1 \right) \right] = -\frac{1}{18}$$

3. Let $I = \int_{\alpha}^{\alpha+1} \frac{dx}{(x+\alpha)(x+\alpha+1)}$
 $= \int_{\alpha}^{\alpha+1} \frac{(x+\alpha+1) - (x+\alpha)}{(x+\alpha)(x+\alpha+1)} dx$
 $= \int_{\alpha}^{\alpha+1} \left(\frac{1}{x+\alpha} - \frac{1}{x+\alpha+1} \right) dx$
 $= [\log_e(x+\alpha) - \log_e(x+\alpha+1)]_{\alpha}^{\alpha+1}$

$$\begin{aligned}
 &= \left[\log_e \left(\frac{x+\alpha}{x+\alpha+1} \right) \right]_0^{\alpha+1} \\
 &= \log_e \frac{2\alpha+1}{2\alpha+2} - \log_e \frac{2\alpha}{2\alpha+1} \\
 &= \log_e \left(\frac{2\alpha+1}{2\alpha+2} \times \frac{2\alpha+1}{2\alpha} \right) = \log_e \left(\frac{9}{8} \right) \quad (\text{given})
 \end{aligned}$$

$$\Rightarrow \frac{(2\alpha+1)^2}{4\alpha(\alpha+1)} = \frac{9}{8} \Rightarrow 8[4\alpha^2 + 4\alpha + 1] = 36(\alpha^2 + \alpha)$$

$$\Rightarrow 8\alpha^2 + 8\alpha + 2 = 9\alpha^2 + 9\alpha \Rightarrow \alpha^2 + \alpha - 2 = 0$$

$$\Rightarrow (\alpha+2)(\alpha-1) = 0 \Rightarrow \alpha = 1, -2$$

From the options we get $\alpha = -2$

$$\begin{aligned}
 4. \text{ Let } I &= \int_0^{\pi/2} \frac{\cot x}{\cot x + \operatorname{cosec} x} dx \\
 &= \int_0^{\pi/2} \frac{\frac{\cos x}{\sin x}}{\frac{\cos x}{\sin x} + \frac{1}{\sin x}} dx = \int_0^{\pi/2} \frac{\cos x}{1 + \cos x} dx \\
 &= \int_0^{\pi/2} \frac{\cos x(1 - \cos x)}{1 - \cos^2 x} dx \\
 &= \int_0^{\pi/2} \frac{\cos x - \cos^2 x}{\sin^2 x} dx \\
 &= \int_0^{\pi/2} (\operatorname{cosec} x \cot x - \cot^2 x) dx \\
 &= \int_0^{\pi/2} (\operatorname{cosec} x \cot x - \operatorname{cosec}^2 x + 1) dx \\
 &= [-\operatorname{cosec} x + \cot x + x]_0^{\pi/2} \\
 &= \left[x + \frac{\cos x - 1}{\sin x} \right]_0^{\pi/2} = \left[x + \frac{(-2 \sin^2 \frac{x}{2})}{2 \sin \frac{x}{2} \cos \frac{x}{2}} \right]_0^{\pi/2} \\
 &= \left[x - \tan \frac{x}{2} \right]_0^{\pi/2} = \frac{\pi}{2} - 1 = \frac{1}{2} [\pi - 2] \\
 &= m[\pi + n] \quad [\text{given}]
 \end{aligned}$$

On comparing, we get $m = \frac{1}{2}$ and $n = -2$

$$\therefore m \cdot n = -1$$

Alternate Solution

$$\begin{aligned}
 \text{Let } I &= \int_0^{\pi/2} \frac{\cot x}{\cot x + \operatorname{cosec} x} dx \\
 &= \int_0^{\pi/2} \frac{\frac{\cos x}{\sin x}}{\frac{\cos x}{\sin x} + \frac{1}{\sin x}} dx = \int_0^{\pi/2} \frac{\cos x}{\cos x + 1} dx \\
 &= \int_0^{\pi/2} \frac{2 \cos^2 \frac{x}{2} - 1}{2 \cos^2 \frac{x}{2}} dx \\
 &= \left[\because \cos \theta = 2 \cos^2 \frac{\theta}{2} - 1 \text{ and } \cos \theta + 1 = 2 \cos^2 \frac{\theta}{2} \right] \\
 &= \int_0^{\pi/2} \left(1 - \frac{1}{2} \sec^2 \frac{x}{2} \right) dx
 \end{aligned}$$

$$= \left[x - \tan \frac{x}{2} \right]_0^{\pi/2} = \frac{\pi}{2} - 1 = \frac{1}{2} (\pi - 2)$$

Since, $I = m(\pi - n)$

$$\therefore m(\pi - n) = \frac{1}{2} (\pi - 2)$$

On comparing both sides, we get

$$m = \frac{1}{2} \text{ and } n = -2$$

$$\text{Now, } mn = \frac{1}{2} \times -2 = -1$$

$$5. \text{ Let } I = \int_{\pi/6}^{\pi/3} \sec^{2/3} x \operatorname{cosec}^{4/3} x dx$$

$$= \int_{\pi/6}^{\pi/3} \frac{1}{\cos^{2/3} x \sin^{4/3} x} dx = \int_{\pi/6}^{\pi/3} \frac{\sec^2 x}{(\tan x)^{4/3}} dx$$

[multiplying and dividing the denominator by $\cos^{4/3} x$]

Put, $\tan x = t$, upper limit, at $x = \pi/3 \Rightarrow t = \sqrt{3}$ and lower limit, at $x = \pi/6 \Rightarrow t = 1/\sqrt{3}$

and $\sec^2 x dx = dt$

$$\begin{aligned}
 \text{So, } I &= \int_{1/\sqrt{3}}^{\sqrt{3}} \frac{dt}{t^{4/3}} = \left[\frac{t^{-1/3}}{-1/3} \right]_{1/\sqrt{3}}^{\sqrt{3}} \\
 &= -3 \left(\frac{1}{3^{1/6}} - 3^{1/6} \right) = 3 \cdot 3^{1/6} - 3 \cdot 3^{-1/6} \\
 &= 3^{7/6} - 3^{5/6}
 \end{aligned}$$

6. Given integral

$$\begin{aligned}
 I &= \int_0^{2\pi} [\sin 2x \cdot (1 + \cos 3x)] dx \\
 &= \int_0^{\pi} [\sin 2x \cdot (1 + \cos 3x)] dx \\
 &\quad + \int_{\pi}^{2\pi} [\sin 2x \cdot (1 + \cos 3x)] dx \\
 &= I_1 + I_2 \text{ (let)} \quad \dots (i)
 \end{aligned}$$

$$\text{Now, } I_2 = \int_{\pi}^{2\pi} [\sin 2x \cdot (1 + \cos 3x)] dx$$

let $2\pi - x = t$, upper limit $t = 0$ and lower limit $t = \pi$

and $dx = -dt$

$$\begin{aligned}
 \text{So, } I_2 &= - \int_{\pi}^0 [-\sin 2x \cdot (1 + \cos 3x)] dx \\
 &= \int_0^{\pi} [-\sin 2x \cdot (1 + \cos 3x)] dx \quad \dots (ii)
 \end{aligned}$$

$$\begin{aligned}
 \therefore I &= \int_0^{\pi} [\sin 2x \cdot (1 + \cos 3x)] dx \\
 &\quad + \int_0^{\pi} [-\sin 2x \cdot (1 + \cos 3x)] dx \\
 &\quad \text{[from Eqs. (i) and (ii)]} \\
 &= \int_0^{\pi} (-1) dx \quad [\because [x] + [-x] = -1, x \notin \text{Integer}] \\
 &= -\pi
 \end{aligned}$$

$$7. \text{ Let } I = \int_0^1 x \cot^{-1}(1 - x^2 + x^4) dx$$

Now, put $x^2 = t \Rightarrow 2x dx = dt$

304 Definite Integration

Lower limit at $x=0, t=0$

Upper limit at $x=1, t=1$

$$\begin{aligned} \therefore I &= \frac{1}{2} \int_0^1 \cot^{-1}(1-t+t^2) dt \\ &= \frac{1}{2} \int_0^1 \tan^{-1} \left(\frac{1}{1-t+t^2} \right) dt \quad \left[\because \cot^{-1} x = \tan^{-1} \frac{1}{x} \right] \\ &= \frac{1}{2} \int_0^1 \tan^{-1} \left(\frac{t-(t-1)}{1+t(t-1)} \right) dt \\ &= \frac{1}{2} \left[\int_0^1 (\tan^{-1} t - \tan^{-1}(t-1)) dt \right] \\ &\quad \left[\because \tan^{-1} \frac{x-y}{1+xy} = \tan^{-1} x - \tan^{-1} y \right] \end{aligned}$$

$$\therefore \int_0^1 \tan^{-1}(t-1) dt = \int_0^1 \tan^{-1}(1-t-1) dt = - \int_0^1 \tan^{-1}(t) dt$$

$$\text{because } \int_0^a f(x) dx = \int_0^a f(a-x) dx$$

$$\begin{aligned} \text{So, } I &= \frac{1}{2} \int_0^1 (\tan^{-1} t + \tan^{-1} t) dt \\ &= \int_0^1 \tan^{-1} t dt = [t \tan^{-1} t]_0^1 - \int_0^1 \frac{t}{1+t^2} dt \\ &\quad \text{[by integration by parts method]} \\ &= \frac{\pi}{4} - \frac{1}{2} [\log_e(1+t^2)]_0^1 = \frac{\pi}{4} - \frac{1}{2} \log_e 2 \end{aligned}$$

8.

Key Idea Use property of definite integral.

$$\int_a^b f(x) dx = \int_a^b f(a+b-x) dx$$

$$\text{Let } I = \int_0^{\pi/2} \frac{\sin^3 x}{\sin x + \cos x} dx \quad \dots(i)$$

On applying the property, $\int_a^b f(x) dx = \int_a^b f(a+b-x) dx$, we get

$$I = \int_0^{\pi/2} \frac{\cos^3 x}{\cos x + \sin x} dx \quad \dots(ii)$$

On adding integrals (i) and (ii), we get

$$\begin{aligned} 2I &= \int_0^{\pi/2} \frac{\sin^3 x + \cos^3 x}{\sin x + \cos x} dx \\ &= \int_0^{\pi/2} \frac{(\sin x + \cos x)(\sin^2 x + \cos^2 x - \sin x \cos x)}{\sin x + \cos x} dx \\ &= \int_0^{\pi/2} \left[1 - \frac{1}{2} (2 \sin x \cos x) \right] dx = \int_0^{\pi/2} \left(1 - \frac{1}{2} \sin 2x \right) dx \\ &= \left[x + \frac{1}{4} \cos 2x \right]_0^{\pi/2} = \left(\frac{\pi}{2} - 0 \right) + \frac{1}{4} (-1 - 1) = \frac{\pi}{2} - \frac{1}{2} \\ \Rightarrow I &= \frac{\pi}{4} - \frac{1}{4} = \frac{\pi-1}{4} \end{aligned}$$

9. Given, $f(x) = \int_0^x g(t) dt$

On replacing x by $(-x)$, we get

$$f(-x) = \int_0^{-x} g(t) dt$$

Now, put $t = -u$, so

$$f(-x) = - \int_0^x g(-u) du = - \int_0^x g(u) du = -f(x)$$

[$\because g$ is an even function]

$$\Rightarrow f(-x) = -f(x)$$

$\Rightarrow f$ is an odd function.

Now, it is given that $f(x+5) = g(x)$

$$\therefore f(5-x) = g(-x) = g(x) = f(x+5)$$

[$\because g$ is an even function]

$$\Rightarrow f(5-x) = f(x+5) \quad \dots(i)$$

$$\text{Let } I = \int_0^x f(t) dt$$

Put $t = u + 5 \Rightarrow t - 5 = u \Rightarrow dt = du$

$$\therefore I = \int_{-5}^{x-5} f(u+5) du = \int_{-5}^{x-5} g(u) du$$

Put $u = -t$

$\Rightarrow du = -dt$, we get

$$I = - \int_{5-x}^5 g(-t) dt = \int_{5-x}^5 g(t) dt$$

$$\left[\because - \int_a^b f(x) dx = \int_b^a f(x) dx \text{ and } g \text{ is an even function} \right]$$

$$I = \int_{5-x}^5 f'(t) dt \quad \text{[by Leibnitz rule } f'(x) = g(x)]$$

$$= f(5) - f(5-x) = f(5) - f(5+x) \quad \text{[from Eq. (i)]}$$

$$= \int_{5+x}^5 f'(t) dt = \int_{5+x}^5 g(t) dt$$

10. The given functions are

$$g(x) = \log_e x, x > 0$$

$$\text{and } f(x) = \frac{2-x \cos x}{2+x \cos x}$$

$$\text{Let } I = \int_{-\pi/4}^{\pi/4} g(f(x)) dx$$

$$\text{Then, } I = \int_{-\pi/4}^{\pi/4} \log_e \left(\frac{2-x \cos x}{2+x \cos x} \right) dx \quad \dots(i)$$

Now, by using the property

$$\int_a^b f(x) dx = \int_a^b f(a+b-x) dx, \text{ we get}$$

$$I = \int_{-\pi/4}^{\pi/4} \log_e \left(\frac{2+x \cos x}{2-x \cos x} \right) dx \quad \dots(ii)$$

On adding Eqs. (i) and (ii), we get

$$\begin{aligned} 2I &= \int_{-\pi/4}^{\pi/4} \left[\log_e \left(\frac{2-x \cos x}{2+x \cos x} \right) + \log_e \left(\frac{2+x \cos x}{2-x \cos x} \right) \right] dx \\ &= \int_{-\pi/4}^{\pi/4} \log_e \left(\frac{2-x \cos x}{2+x \cos x} \times \frac{2+x \cos x}{2-x \cos x} \right) dx \\ & \quad [\because \log_e A + \log_e B = \log_e AB] \\ \Rightarrow 2I &= \int_{-\pi/4}^{\pi/4} \log_e (1) dx = 0 \Rightarrow I = 0 = \log_e (1) \end{aligned}$$

11. Let $I = \int_0^a f(x) g(x) dx \quad \dots (i)$

$$= \int_0^a f(a-x) g(a-x) dx \quad \left[\because \int_0^a f(x) dx = \int_0^a f(a-x) dx \right]$$

$$\begin{aligned} \Rightarrow I &= \int_0^a f(x) [4 - g(x)] dx \\ & \quad [\because f(x) = f(a-x) \text{ and } g(x) + g(a-x) = 4] \\ &= \int_0^a 4f(x) dx - \int_0^a f(x) g(x) dx \end{aligned}$$

$$\Rightarrow I = 4 \int_0^a f(x) dx - I \quad \text{[from Eq. (i)]}$$

$$\Rightarrow 2I = 4 \int_0^a f(x) dx \Rightarrow I = 2 \int_0^a f(x) dx.$$

12. Let $I = \int_1^e \left\{ \left(\frac{x}{e} \right)^{2x} - \left(\frac{e}{x} \right)^x \right\} \log_e x dx$

Now, put $\left(\frac{x}{e} \right)^x = t \Rightarrow x \log_e \left(\frac{x}{e} \right) = \log t$

$$\Rightarrow x (\log_e x - \log_e e) = \log t$$

$$\Rightarrow \left[x \left(\frac{1}{x} \right) + (\log_e x - \log_e e) \right] dx = \frac{1}{t} dt$$

$$\Rightarrow (1 + \log_e x - 1) dx = \frac{1}{t} dt \Rightarrow (\log_e x) dx = \frac{1}{t} dt$$

Also, upper limit $x = e \Rightarrow t = 1$ and lower limit $x = 1 \Rightarrow t = \frac{1}{e}$

$$\therefore I = \int_{1/e}^1 \left(t^2 - \frac{1}{t} \right) \cdot \frac{1}{t} dt$$

$$\Rightarrow I = \int_{1/e}^1 (t - t^{-2}) dt$$

$$I = \left[\left(\frac{t^2}{2} + \frac{1}{t} \right) \right]_{1/e}^1 = \left\{ \left(\frac{1}{2} + 1 \right) - \left(\frac{1}{2e^2} + e \right) \right\} = \frac{3}{2} - e - \frac{1}{2e^2}$$

13. Let $I = \int_{\pi/6}^{\pi/4} \frac{dx}{\sin 2x (\tan^5 x + \cot^5 x)}$

$$= \int_{\pi/6}^{\pi/4} \frac{(1 + \tan^2 x) \tan^5 x}{2 \tan x (\tan^{10} x + 1)} dx \quad \left[\because \sin 2x = \frac{2 \tan x}{1 + \tan^2 x} \right]$$

$$= \frac{1}{2} \int_{\pi/6}^{\pi/4} \frac{\tan^4 x \sec^2 x}{(\tan^{10} x + 1)} dx$$

Put $\tan^5 x = t \quad [\because \sec^2 x = 1 + \tan^2 x]$

$$\Rightarrow 5 \tan^4 x \sec^2 x dx = dt$$

x	$\frac{\pi}{6}$	$\frac{\pi}{4}$
t	$\left(\frac{1}{\sqrt{3}} \right)^5$	1

$$\therefore I = \frac{1}{2} \cdot \frac{1}{5} \int_{(1/\sqrt{3})^5}^1 \frac{dt}{t^2 + 1} = \frac{1}{10} (\tan^{-1}(t)) \Big|_{(1/\sqrt{3})^5}^1$$

$$= \frac{1}{10} \left(\tan^{-1}(1) - \tan^{-1} \left(\frac{1}{9\sqrt{3}} \right) \right)$$

$$= \frac{1}{10} \left(\frac{\pi}{4} - \tan^{-1} \left(\frac{1}{9\sqrt{3}} \right) \right)$$

14. Let $I = \int_{-2}^2 \frac{\sin^2 x}{\frac{1}{2} + \left[\frac{x}{\pi} \right]} dx$

Also, let $f(x) = \frac{\sin^2 x}{\frac{1}{2} + \left[\frac{x}{\pi} \right]}$

Then, $f(-x) = \frac{\sin^2(-x)}{\frac{1}{2} + \left[\frac{-x}{\pi} \right]}$ (replacing x by $-x$)

$$= \frac{\sin^2 x}{\frac{1}{2} + \left(-1 - \left[\frac{x}{\pi} \right] \right)}$$

$$\left[\because [-x] = \begin{cases} -[x], & \text{if } x \in I \\ -1 - [x], & \text{if } x \notin I \end{cases} \right]$$

$$\Rightarrow f(-x) = - \frac{\sin^2 x}{\frac{1}{2} + \left[\frac{x}{\pi} \right]} = -f(x)$$

i.e. $f(x)$ is odd function

$$\therefore I = 0$$

$$\left[\because \int_{-a}^a f(x) dx = \begin{cases} 0, & \text{if } f(x) \text{ is odd function} \\ 2 \int_0^a f(x) dx, & \text{if } f(x) \text{ is even function} \end{cases} \right]$$

15. We have, $I = \int_a^b (x^4 - 2x^2) dx$

Let $f(x) = x^4 - 2x^2 = x^2(x^2 - 2) = x^2(x - \sqrt{2})(x + \sqrt{2})$

Graph of $y = f(x) = x^4 - 2x^2$ is

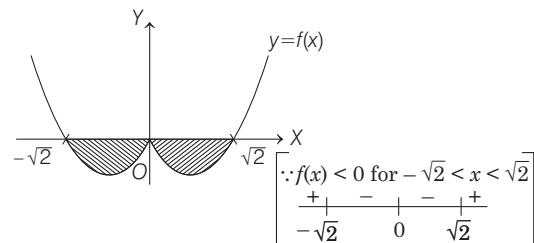

Note that the definite integral $\int_a^b (x^4 - 2x^2) dx$ represent the area bounded by $y = f(x)$, $x = a$, b and the X -axis.

306 Definite Integration

But between $x = -\sqrt{2}$ and $x = \sqrt{2}$, $f(x)$ lies below the X -axis and so value definite integral will be negative.

Also, as long as $f(x)$ lie below the X -axis, the value of definite integral will be minimum.

$\therefore (a, b) = (-\sqrt{2}, \sqrt{2})$ for minimum of I .

16. We have, $\int_0^{\pi/3} \frac{\tan \theta}{\sqrt{2k \sec \theta}} d\theta = 1 - \frac{1}{\sqrt{2}}$, ($k > 0$)

$$\begin{aligned} \text{Let } I &= \int_0^{\pi/3} \frac{\tan \theta}{\sqrt{2k \sec \theta}} d\theta = \frac{1}{\sqrt{2k}} \int_0^{\pi/3} \frac{\tan \theta}{\sqrt{\sec \theta}} d\theta \\ &= \frac{1}{\sqrt{2k}} \int_0^{\pi/3} \frac{(\sin \theta)}{(\cos \theta) \sqrt{\frac{1}{\cos \theta}}} d\theta = \frac{1}{\sqrt{2k}} \int_0^{\pi/3} \frac{\sin \theta}{\sqrt{\cos \theta}} d\theta \end{aligned}$$

Let $\cos \theta = t \Rightarrow -\sin \theta d\theta = dt \Rightarrow \sin \theta d\theta = -dt$

for lower limit, $\theta = 0 \Rightarrow t = \cos 0 = 1$

for upper limit, $\theta = \frac{\pi}{3} \Rightarrow t = \cos \frac{\pi}{3} = \frac{1}{2}$

$$\begin{aligned} \Rightarrow I &= \frac{1}{\sqrt{2k}} \int_1^{1/2} \frac{-dt}{\sqrt{t}} = \frac{-1}{\sqrt{2k}} \int_1^{1/2} t^{-1/2} dt \\ &= -\frac{1}{\sqrt{2k}} \left[\frac{t^{-1/2+1}}{-1/2+1} \right]_1^{1/2} = -\frac{1}{\sqrt{2k}} [2\sqrt{t}]_1^{1/2} \\ &= -\frac{2}{\sqrt{2k}} \left[\sqrt{\frac{1}{2}} - \sqrt{1} \right] = \frac{2}{\sqrt{2k}} \left(1 - \frac{1}{\sqrt{2}} \right) \\ \therefore I &= 1 - \frac{1}{\sqrt{2}} \quad (\text{given}) \end{aligned}$$

$$\therefore \frac{2}{\sqrt{2k}} \left(1 - \frac{1}{\sqrt{2}} \right) = 1 - \frac{1}{\sqrt{2}} \Rightarrow \frac{2}{\sqrt{2k}} = 1$$

$$\Rightarrow 2 = \sqrt{2k} \Rightarrow 2k = 4 \Rightarrow k = 2$$

17. We know, graph of $y = \cos x$ is

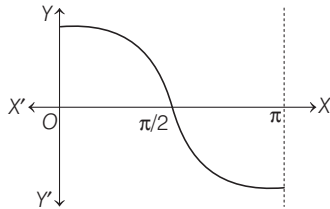

\therefore The graph of $y = |\cos x|$ is

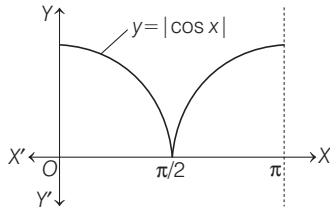

$$I = \int_0^{\pi} |\cos x|^3 dx = 2 \int_0^{\pi/2} |\cos x|^3 dx$$

($\because y = |\cos x|$ is symmetric about $x = \frac{\pi}{2}$)

$$= 2 \int_0^{\pi/2} \cos^3 x dx \quad \left[\because \cos x \geq 0 \text{ for } x \in \left[0, \frac{\pi}{2} \right] \right]$$

Now, as $\cos 3x = 4 \cos^3 x - 3 \cos x$

$$\therefore \cos^3 x = \frac{1}{4} (\cos 3x + 3 \cos x)$$

$$\begin{aligned} \therefore I &= \frac{2}{4} \int_0^{\pi/2} (\cos 3x + 3 \cos x) dx \\ &= \frac{1}{2} \left[\frac{\sin 3x}{3} + 3 \sin x \right]_0^{\pi/2} \\ &= \frac{1}{2} \left\{ \left[\frac{1}{3} \sin \frac{3\pi}{2} + 3 \sin \frac{\pi}{2} \right] - \left[\frac{1}{3} \sin 0 + 3 \sin 0 \right] \right\} \\ &= \frac{1}{2} \left\{ \left[\frac{1}{3} (-1) + 3 \right] - [0 + 0] \right\} \\ &= \frac{1}{2} \left[-\frac{1}{3} + 3 \right] = \frac{4}{3} \quad \left[\because \sin \frac{3\pi}{2} = \sin \left(\pi + \frac{\pi}{2} \right) = -\sin \frac{\pi}{2} = -1 \right] \end{aligned}$$

18. Key idea Use property $\int_a^b f(x) dx = \int_a^b f(a+b-x) dx$

$$\begin{aligned} \text{Let } I &= \int_{-\pi/2}^{\pi/2} \frac{\sin^2 x}{1+2^x} dx \\ \Rightarrow I &= \int_{-\pi/2}^{\pi/2} \frac{\sin^2 \left(-\frac{\pi}{2} + \frac{\pi}{2} - x \right)}{1+2^{-\frac{\pi}{2} + \frac{\pi}{2} - x}} dx \\ &= \int_a^b f(x) dx = \int_a^b f(a+b-x) dx \end{aligned}$$

$$\begin{aligned} \Rightarrow I &= \int_{-\pi/2}^{\pi/2} \frac{\sin^2 x}{1+2^{-x}} dx \\ \Rightarrow I &= \int_{-\pi/2}^{\pi/2} \frac{2^x \sin^2 x}{2^x + 1} dx \\ \Rightarrow 2I &= \int_{-\pi/2}^{\pi/2} \sin^2 x \left(\frac{2^x + 1}{2^x + 1} \right) dx \\ \Rightarrow 2I &= \int_{-\pi/2}^{\pi/2} \sin^2 x dx \\ \Rightarrow 2I &= 2 \int_0^{\pi/2} \sin^2 x dx \quad [\because \sin^2 x \text{ is an even function}] \end{aligned}$$

$$\begin{aligned} \Rightarrow I &= \int_0^{\pi/2} \sin^2 x dx \\ \Rightarrow I &= \int_0^{\pi/2} \cos^2 x dx \quad \left[\because \int_0^a f(x) dx = \int_0^a f(a-x) dx \right] \end{aligned}$$

$$\Rightarrow 2I = \int_0^{\pi/2} dx$$

$$\Rightarrow 2I = [x]_0^{\pi/2}$$

$$\Rightarrow I = \frac{\pi}{4}$$

$$\begin{aligned}
 19. \text{ Let } I &= \int_{\pi/4}^{3\pi/4} \frac{dx}{1 + \cos x} = \int_{\pi/4}^{3\pi/4} \frac{1 - \cos x}{1 - \cos^2 x} dx \\
 &= \int_{\pi/4}^{3\pi/4} \frac{1 - \cos x}{\sin^2 x} dx \\
 &= \int_{\pi/4}^{3\pi/4} (\operatorname{cosec}^2 x - \operatorname{cosec} x \cot x) dx \\
 &= [-\cot x + \operatorname{cosec} x]_{\pi/4}^{3\pi/4} \\
 &= [(1 + \sqrt{2}) - (-1 + \sqrt{2})] = 2
 \end{aligned}$$

$$\begin{aligned}
 20. \text{ Let } I &= \int_{-\pi/2}^{\pi/2} \frac{x^2 \cos x}{1 + e^x} dx \quad \dots(i) \\
 &\quad \left[\because \int_a^b f(x) dx = \int_a^b f(a+b-x) dx \right] \\
 \Rightarrow I &= \int_{-\pi/2}^{\pi/2} \frac{x^2 \cos(-x)}{1 + e^{-x}} dx \quad \dots(ii)
 \end{aligned}$$

On adding Eqs. (i) and (ii), we get

$$\begin{aligned}
 2I &= \int_{-\pi/2}^{\pi/2} x^2 \cos x \left[\frac{1}{1 + e^x} + \frac{1}{1 + e^{-x}} \right] dx \\
 &= \int_{-\pi/2}^{\pi/2} x^2 \cos x \cdot (1) dx \\
 &\quad \left[\because \int_{-a}^a f(x) dx = 2 \int_0^a f(x) dx, \text{ when } f(-x) = f(x) \right] \\
 \Rightarrow 2I &= 2 \int_0^{\pi/2} x^2 \cos x dx
 \end{aligned}$$

Using integration by parts, we get

$$\begin{aligned}
 2I &= 2 [x^2(\sin x) - (2x)(-\cos x) + (2)(-\sin x)]_0^{\pi/2} \\
 \Rightarrow 2I &= 2 \left[\frac{\pi^2}{4} - 2 \right] \\
 \therefore I &= \frac{\pi^2}{4} - 2
 \end{aligned}$$

21. **PLAN** Apply the property $\int_a^b f(x) dx = \int_a^b f(a+b-x) dx$ and then add.

$$\begin{aligned}
 \text{Let } I &= \int_2^4 \frac{\log x^2}{\log x^2 + \log(36 - 12x + x^2)} dx \\
 &= \int_2^4 \frac{2 \log x}{2 \log x + \log(6-x)^2} dx \\
 &= \int_2^4 \frac{2 \log x dx}{2[\log x + \log(6-x)]} \\
 \Rightarrow I &= \int_2^4 \frac{\log x dx}{[\log x + \log(6-x)]} \quad \dots(i) \\
 \Rightarrow I &= \int_2^4 \frac{\log(6-x)}{\log(6-x) + \log x} dx \quad \dots(ii) \\
 &\quad \left[\because \int_a^b f(x) dx = \int_a^b f(a+b-x) dx \right]
 \end{aligned}$$

On adding Eqs. (i) and (ii), we get

$$\begin{aligned}
 2I &= \int_2^4 \frac{\log x + \log(6-x)}{\log x + \log(6-x)} dx \\
 \Rightarrow 2I &= \int_2^4 dx = [x]_2^4 \Rightarrow 2I = 2 \\
 \Rightarrow 2I &= 2 \Rightarrow I = 1
 \end{aligned}$$

22. **PLAN** This type of question can be done using appropriate substitution.

$$\begin{aligned}
 \text{Given, } I &= \int_{\pi/4}^{\pi/2} (2 \operatorname{cosec} x)^{17} dx \\
 &= \int_{\pi/4}^{\pi/2} \frac{2^{17} (\operatorname{cosec} x)^{16} \operatorname{cosec} x (\operatorname{cosec} x + \cot x)}{(\operatorname{cosec} x + \cot x)} dx
 \end{aligned}$$

Let $\operatorname{cosec} x + \cot x = t$

$$\Rightarrow (-\operatorname{cosec} x \cdot \cot x - \operatorname{cosec}^2 x) dx = dt$$

and $\operatorname{cosec} x - \cot x = 1/t$

$$\Rightarrow 2 \operatorname{cosec} x = t + \frac{1}{t}$$

$$\therefore I = - \int_{\sqrt{2}+1}^1 2^{17} \left(\frac{t + \frac{1}{t}}{2} \right)^{16} \frac{dt}{t}$$

Let $t = e^u \Rightarrow dt = e^u du$.

When $t = 1, e^u = 1 \Rightarrow u = 0$

and when $t = \sqrt{2} + 1, e^u = \sqrt{2} + 1$

$$\Rightarrow u = \ln(\sqrt{2} + 1)$$

$$\begin{aligned}
 \Rightarrow I &= - \int_{\ln(\sqrt{2}+1)}^0 2(e^u + e^{-u})^{16} \frac{e^u du}{e^u} \\
 &= 2 \int_0^{\ln(\sqrt{2}+1)} (e^u + e^{-u})^{16} du
 \end{aligned}$$

23. **PLAN** Use the formula, $|x - a| = \begin{cases} x - a, & x \geq a \\ -(x - a), & x < a \end{cases}$

to break given integral in two parts and then integrate separately.

$$\begin{aligned}
 \int_0^{\pi} \sqrt{\left(1 - 2 \sin \frac{x}{2}\right)^2} dx &= \int_0^{\pi} |1 - 2 \sin \frac{x}{2}| dx \\
 &= \int_0^{\frac{\pi}{3}} \left(1 - 2 \sin \frac{x}{2}\right) dx - \int_{\frac{\pi}{3}}^{\pi} \left(1 - 2 \sin \frac{x}{2}\right) dx \\
 &= \left(x + 4 \cos \frac{x}{2}\right)_0^{\frac{\pi}{3}} - \left(x + 4 \cos \frac{x}{2}\right)_{\frac{\pi}{3}}^{\pi} = 4\sqrt{3} - 4 - \frac{\pi}{3}
 \end{aligned}$$

$$24. I = \int_{-\pi/2}^{\pi/2} \left[x^2 + \log \left(\frac{\pi - x}{\pi + x} \right) \right] \cos x dx$$

As, $\int_{-a}^a f(x) dx = 0$, when $f(-x) = -f(x)$

$$\begin{aligned}
 \therefore I &= \int_{-\pi/2}^{\pi/2} x^2 \cos x dx + 0 = 2 \int_0^{\pi/2} (x^2 \cos x) dx \\
 &= 2 \left\{ (x^2 \sin x)_0^{\pi/2} - \int_0^{\pi/2} 2x \cdot \sin x dx \right\} \\
 &= 2 \left[\frac{\pi^2}{4} - 2 \left\{ (-x \cdot \cos x)_0^{\pi/2} - \int_0^{\pi/2} 1 \cdot (-\cos x) dx \right\} \right] \\
 &= 2 \left[\frac{\pi^2}{4} - 2 (\sin x)_0^{\pi/2} \right] = 2 \left[\frac{\pi^2}{4} - 2 \right] = \left(\frac{\pi^2}{2} - 4 \right)
 \end{aligned}$$

25. Put $x^2 = t$

$$\Rightarrow x dx = dt/2$$

$$\therefore I = \int_{\log^2 \sin t}^{\log^2 \sin t + \sin(\log 6 - t)} \frac{\sin t \cdot \frac{dt}{2}}{2} \quad \dots(i)$$

308 Definite Integration

Using, $\int_a^b f(x) dx = \int_a^b f(a+b-x) dx$

$$= \frac{1}{2} \int_{\log 2}^{\log 3} \frac{\sin(\log 2 + \log 3 - t)}{\sin(\log 2 + \log 3 - t) + \sin(\log 6 - (\log 2 + \log 3 - t))} dt$$

$$= \frac{1}{2} \int_{\log 2}^{\log 3} \frac{\sin(\log 6 - t)}{\sin(\log 6 - t) + \sin t} dt$$

$$\therefore I = \int_{\log 2}^{\log 3} \frac{\sin(\log 6 - t)}{\sin(\log 6 - t) + \sin t} dt \quad \dots(ii)$$

On adding Eqs. (i) and (ii), we get

$$2I = \frac{1}{2} \int_{\log 2}^{\log 3} \frac{\sin t + \sin(\log 6 - t)}{\sin(\log 6 - t) + \sin t} dt$$

$$\Rightarrow 2I = \frac{1}{2} (t)_{\log 2}^{\log 3} = \frac{1}{2} (\log 3 - \log 2)$$

$$\therefore I = \frac{1}{4} \log\left(\frac{3}{2}\right)$$

26. Let $I = \int_{-2}^0 [x^3 + 3x^2 + 3x + 3 + (x+1) \cos(x+1)] dx$

$$= \int_{-2}^0 [(x+1)^3 + 2 + (x+1) \cos(x+1)] dx$$

Put $x+1 = t$

$$\Rightarrow dx = dt$$

$$\therefore I = \int_{-1}^1 (t^3 + 2 + t \cos t) dt$$

$$= \int_{-1}^1 t^3 dt + 2 \int_{-1}^1 dt + \int_{-1}^1 t \cos t dt$$

$$= 0 + 2 \cdot 2 [x]_0^1 + 0 = 4$$

[since, t^3 and $t \cos t$ are odd functions]

27. $I = \int_0^1 \sqrt{\frac{1-x}{1+x}} dx = \int_0^1 \frac{1-x}{\sqrt{1-x^2}} dx$

$$= \int_0^1 \frac{1}{\sqrt{1-x^2}} dx - \int_0^1 \frac{x}{\sqrt{1-x^2}} dx = [\sin^{-1} x]_0^1 + \int_1^0 \frac{t}{t} dt$$

[where, $t^2 = 1 - x^2 \Rightarrow t dt = -x dx$]

$$= (\sin^{-1} 1 - \sin^{-1} 0) + [t]_1^0 = \pi/2 - 1$$

28. $\int_{-1/2}^{1/2} [x + \log\left(\frac{1+x}{1-x}\right)] dx$

$$= \int_{-1/2}^{1/2} [x] dx + \int_{-1/2}^{1/2} \log\left(\frac{1+x}{1-x}\right) dx$$

$$= \int_{-1/2}^{1/2} [x] dx + 0 \quad \left[\because \log\left(\frac{1+x}{1-x}\right) \text{ is an odd function} \right]$$

$$= \int_{-1/2}^0 [x] dx + \int_0^{1/2} [x] dx = \int_{-1/2}^0 (-1) dx + \int_0^{1/2} (0) dx$$

$$= -[x]_{-1/2}^0 = -\left(0 + \frac{1}{2}\right) = -\frac{1}{2}$$

29. Let $I = \int_{-\pi}^{\pi} \frac{\cos^2 x}{1+a^x} dx \quad \dots(i)$

$$= \int_{\pi}^{-\pi} \frac{\cos^2(-x)}{1+a^{-x}} d(-x)$$

$$\Rightarrow I = \int_{-\pi}^{\pi} a^x \frac{\cos^2 x}{1+a^x} dx \quad \dots(ii)$$

On adding Eqs. (i) and (ii), we get

$$2I = \int_{-\pi}^{\pi} \left(\frac{1+a^x}{1+a^x}\right) \cos^2 x dx$$

$$= \int_{-\pi}^{\pi} \cos^2 x dx = 2 \int_0^{\pi} \frac{1 + \cos 2x}{2} dx$$

$$= \int_0^{\pi} (1 + \cos 2x) dx = \int_0^{\pi} 1 dx + \int_0^{\pi} \cos 2x dx$$

$$= [x]_0^{\pi} + 2 \int_0^{\pi/2} \cos 2x dx = \pi + 0$$

$$\Rightarrow 2I = \pi \Rightarrow I = \pi/2$$

30. Given, $f(x) = \begin{cases} e^{\cos x} \sin x, & \text{for } |x| \leq 2 \\ 2, & \text{otherwise} \end{cases}$

$$\therefore \int_{-2}^3 f(x) dx = \int_{-2}^2 f(x) dx + \int_2^3 f(x) dx$$

$$= \int_{-2}^2 e^{\cos x} \sin x dx + \int_2^3 2 dx = 0 + 2 [x]_2^3$$

[$\because e^{\cos x} \sin x$ is an odd function]

$$= 2 [3 - 2] = 2 \quad \left[\because \int_{-2}^2 f(x) dx = 2 \right]$$

31. $\int_{e^{-1}}^{e^2} \left| \frac{\log_e x}{x} \right| dx = \int_{e^{-1}}^1 \left| \frac{\log_e x}{x} \right| dx - \int_1^{e^2} \left| \frac{\log_e x}{x} \right| dx$

[since, 1 is turning point for $\left| \frac{\log_e x}{x} \right|$ for +ve and -ve values]

$$= -\int_{e^{-1}}^1 \frac{\log_e x}{x} dx + \int_1^{e^2} \frac{\log_e x}{x} dx$$

$$= -\frac{1}{2} [(\log_e x)^2]_{e^{-1}}^1 + \frac{1}{2} [(\log_e x)^2]_1^{e^2}$$

$$= -\frac{1}{2} \{0 - (-1)^2\} + \frac{1}{2} (2^2 - 0) = \frac{5}{2}$$

32. The graph of $y = 2 \sin x$ for $\pi/2 \leq x \leq 3\pi/2$ is given in figure. From the graph, it is clear that

$$[2 \sin x] = \begin{cases} 2, & \text{if } x = \pi/2 \\ 1, & \text{if } \pi/2 < x \leq 5\pi/6 \\ 0, & \text{if } 5\pi/6 < x \leq \pi \\ -1, & \text{if } \pi < x \leq 7\pi/6 \\ -2, & \text{if } 7\pi/6 < x \leq 3\pi/2 \end{cases}$$

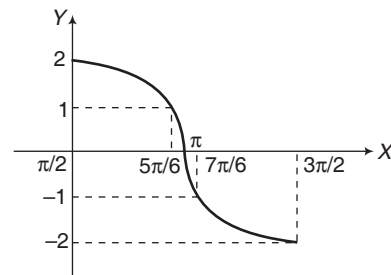

Therefore, $\int_{\pi/2}^{3\pi/2} [2 \sin x] dx$

$$= \int_{\pi/2}^{5\pi/6} dx + \int_{5\pi/6}^{\pi} 0 dx + \int_{\pi}^{7\pi/6} (-1) dx + \int_{7\pi/6}^{3\pi/2} (-2) dx$$

$$= [x]_{\pi/2}^{5\pi/6} + [-x]_{\pi}^{7\pi/6} + [-2x]_{7\pi/6}^{3\pi/2}$$

$$= \left(\frac{5\pi}{6} - \frac{\pi}{2}\right) + \left(-\frac{7\pi}{6} + \pi\right) + \left(\frac{-2 \cdot 3\pi}{2} + \frac{2 \cdot 7\pi}{6}\right)$$

$$= \pi \left(\frac{5}{6} - \frac{1}{2}\right) + \pi \left(1 - \frac{7}{6}\right) + \pi \left(\frac{7}{3} - 3\right)$$

$$= \pi \left(\frac{5-3}{6}\right) + \pi \left(-\frac{1}{6}\right) + \pi \left(\frac{7-9}{3}\right) = -\pi/2$$

33. Let $I = \int_{\pi/4}^{3\pi/4} \frac{dx}{1 + \cos x}$... (i)

$$\Rightarrow I = \int_{\pi/4}^{3\pi/4} \frac{dx}{1 + \cos(\pi - x)}$$

$$I = \int_{\pi/4}^{3\pi/4} \frac{dx}{1 - \cos x}$$
 ... (ii)

On adding Eqs. (i) and (ii), we get

$$2I = \int_{\pi/4}^{3\pi/4} \left(\frac{1}{1 + \cos x} + \frac{1}{1 - \cos x}\right) dx$$

$$\Rightarrow 2I = \int_{\pi/4}^{3\pi/4} \left(\frac{2}{1 - \cos^2 x}\right) dx$$

$$\Rightarrow I = \int_{\pi/4}^{3\pi/4} \operatorname{cosec}^2 x dx = [-\cot x]_{\pi/4}^{3\pi/4}$$

$$= \left[-\cot \frac{3\pi}{4} + \cot \frac{\pi}{4}\right] = -(-1) + 1 = 2$$

34. Let $\int_{-1}^1 f(x) dx = \int_{-1}^1 (x - [x]) dx = \int_{-1}^1 x dx - \int_{-1}^1 [x] dx$

$$= 0 - \int_{-1}^1 [x] dx \quad [\because x \text{ is an odd function}]$$

But $[x] = \begin{cases} -1, & \text{if } -1 \leq x < 0 \\ 0, & \text{if } 0 \leq x < 1 \\ 1, & \text{if } x = 1 \end{cases}$

$$\therefore \int_{-1}^1 [x] dx = \int_{-1}^0 [x] dx + \int_0^1 [x] dx$$

$$= \int_{-1}^0 (-1) dx + \int_0^1 0 dx$$

$$= -[x]_{-1}^0 + 0 = -1; \therefore \int_{-1}^1 f(x) dx = 1$$

35. Given, $g(x) = \int_0^x \cos^4 t dt$

$$\Rightarrow g(x + \pi) = \int_0^{\pi+x} \cos^4 t dt$$

$$= \int_0^{\pi} \cos^4 t dt + \int_{\pi}^{\pi+x} \cos^4 t dt = I_1 + I_2$$

where, $I_1 = \int_0^{\pi} \cos^4 t dt = g(\pi)$

and $I_2 = \int_{\pi}^{\pi+x} \cos^4 t dt$

Put $t = \pi + y$

$$\Rightarrow dt = dy$$

$$I_2 = \int_0^x \cos^4 (y + \pi) dy$$

$$= \int_0^x (-\cos y)^4 dy = \int_0^x \cos^4 y dy = g(x)$$

$$\therefore g(x + \pi) = g(\pi) + g(x)$$

36. Given, $I_1 = \int_{1-k}^k x f [x(1-x)] dx$

$$\Rightarrow I_1 = \int_{1-k}^k (1-x) f [(1-x)x] dx$$

$$= \int_{1-k}^k f [(1-x)] dx - \int_{1-k}^k x f (1-x) dx$$

$$\Rightarrow I_1 = I_2 - I_1 \Rightarrow \frac{I_1}{I_2} = \frac{1}{2}$$

37. It is a question of greatest integer function. We have, subdivide the interval π to 2π as under keeping in view that we have to evaluate $[2 \sin x]$

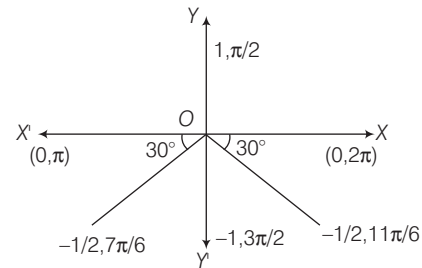

We know that, $\sin \frac{\pi}{6} = \frac{1}{2}$

$$\therefore \sin \left(\pi + \frac{\pi}{6}\right) = \sin \frac{7\pi}{6} = -\frac{1}{2}$$

$$\Rightarrow \sin \frac{11\pi}{6} = \sin \left(2\pi - \frac{\pi}{6}\right) = -\sin \frac{\pi}{6} = -\frac{1}{2}$$

$$\Rightarrow \sin \frac{9\pi}{6} = \sin \frac{3\pi}{6} = -1$$

Hence, we divide the interval π to 2π as

$$\left(\pi, \frac{7\pi}{6}\right), \left(\frac{7\pi}{6}, \frac{11\pi}{6}\right), \left(\frac{11\pi}{6}, 2\pi\right)$$

$$\sin x = \left(0, -\frac{1}{2}\right), \left(-1, -\frac{1}{2}\right), \left(-\frac{1}{2}, 0\right)$$

$$\Rightarrow 2 \sin x = (0, -1), (-2, -1), (-1, 0)$$

$$\Rightarrow [2 \sin x] = -1$$

$$= \int_{\pi}^{7\pi/6} [2 \sin x] dx + \int_{7\pi/6}^{11\pi/6} [2 \sin x] dx$$

$$+ \int_{11\pi/6}^{2\pi} [2 \sin x] dx$$

$$= \int_{\pi}^{7\pi/6} (-1) dx + \int_{7\pi/6}^{11\pi/6} (-2) dx + \int_{11\pi/6}^{2\pi} (-1) dx$$

$$= -\frac{\pi}{6} - 2\left(\frac{4\pi}{6}\right) - \frac{\pi}{6} = -\frac{10\pi}{6} = -\frac{5\pi}{3}$$

310 Definite Integration

38. Given, $f(x) = A \sin\left(\frac{\pi x}{2}\right) + B, f'\left(\frac{1}{2}\right) = \sqrt{2}$

and $\int_0^1 f(x) dx = \frac{2A}{\pi}$

$f'(x) = \frac{A\pi}{2} \cos \frac{\pi x}{2} \Rightarrow f'\left(\frac{1}{2}\right) = \frac{A\pi}{2} \cos \frac{\pi}{4} = \frac{A\pi}{2\sqrt{2}}$

But $f'\left(\frac{1}{2}\right) = \sqrt{2} \therefore \frac{A\pi}{2\sqrt{2}} = \sqrt{2} \Rightarrow A = \frac{4}{\pi}$

Now, $\int_0^1 f(x) dx = \frac{2A}{\pi} \Rightarrow \int_0^1 \left\{ A \sin\left(\frac{\pi x}{2}\right) + B \right\} dx = \frac{2A}{\pi}$

$\Rightarrow \left[-\frac{2A}{\pi} \cos \frac{\pi x}{2} + Bx \right]_0^1 = \frac{2A}{\pi}$

$\Rightarrow B + \frac{2A}{\pi} = \frac{2A}{\pi}$

$\Rightarrow B = 0$

39. Let $I = \int_0^{\pi/2} \frac{1}{1 + \tan^3 x} dx = \int_0^{\pi/2} \frac{1}{1 + \frac{\sin^3 x}{\cos^3 x}} dx$

$\Rightarrow I = \int_0^{\pi/2} \frac{\cos^3 x}{\cos^3 x + \sin^3 x} dx \dots(i)$

$\Rightarrow I = \int_0^{\pi/2} \frac{\cos^3\left(\frac{\pi}{2} - x\right)}{\cos^3\left(\frac{\pi}{2} - x\right) + \sin^3\left(\frac{\pi}{2} - x\right)} dx$

$\Rightarrow I = \int_0^{\pi/2} \frac{\sin^3 x}{\sin^3 x + \cos^3 x} dx \dots(ii)$

On adding Eqs. (i) and (ii), we get

$2I = \int_0^{\pi/2} 1 dx \Rightarrow 2I = [x]_0^{\pi/2} = \pi/2 \Rightarrow I = \pi/4$

40. Let $I = \int_{-\pi/2}^{\pi/2} [f(x) + f(-x)] [g(x) - g(-x)] dx$

Let $\phi(x) = [f(x) + f(-x)] [g(x) - g(-x)]$

$\Rightarrow \phi(-x) = [f(-x) + f(x)] [g(-x) - g(x)]$

$\Rightarrow \phi(-x) = -\phi(x)$

$\Rightarrow \phi(x)$ is an odd function.

$\therefore \int_{-\pi/2}^{\pi/2} \phi(x) dx = 0$

41. Let $I = \int_0^{\pi} e^{\cos^2 x} \cdot \cos^3 \{(2n+1)x\} dx$

Using $\int_0^a f(x) dx = \begin{cases} 0, & f(a-x) = -f(x) \\ 2 \int_0^{a/2} f(x) dx, & f(a-x) = f(x) \end{cases}$

Again, let $f(x) = e^{\cos^2 x} \cdot \cos^3 \{(2n+1)x\}$

$\therefore f(\pi-x) = (e^{\cos^2 x}) \{-\cos^3 \{(2n+1)x\}\} = -f(x)$

$\therefore I = 0$

42. Let $I = \int_0^{\pi/2} \frac{\sqrt{\cot x}}{\sqrt{\cot x} + \sqrt{\tan x}} dx \dots(i)$

$\Rightarrow I = \int_0^{\pi/2} \frac{\sqrt{\tan x}}{\sqrt{\cot x} + \sqrt{\tan x}} dx \dots(ii)$

On adding Eqs. (i) and (ii), we get

$2I = \int_0^{\pi/2} 1 dx$

$\therefore I = \frac{\pi}{4}$

43. Let $I = \int_{\pi/6}^{\pi/3} \frac{dx}{1 + \sqrt{\tan x}} \dots(i)$

$\therefore I = \int_{\pi/6}^{\pi/3} \frac{dx}{1 + \sqrt{\tan\left(\frac{\pi}{2} - x\right)}}$

$= \int_{\pi/6}^{\pi/3} \frac{dx}{1 + \sqrt{\cot x}}$

$\Rightarrow I = \int_{\pi/6}^{\pi/3} \frac{\sqrt{\tan x} dx}{1 + \sqrt{\tan x}} \dots(ii)$

On adding Eqs. (i) and (ii), we get

$2I = \int_{\pi/6}^{\pi/3} dx$

$\Rightarrow 2I = [x]_{\pi/6}^{\pi/3} dx$

$\Rightarrow I = \frac{1}{2} \left[\frac{\pi}{3} - \frac{\pi}{6} \right] = \frac{\pi}{12}$

Statement I is false.

But $\int_a^b f(x) dx = \int_a^b f(a+b-x) dx$ is a true statement by property of definite integrals.

44. According to the given data,

$F'(x) < 0, \forall x \in (1, 3)$

We have, $f(x) = xF(x)$

$\Rightarrow f'(x) = F(x) + xF'(x) \dots(i)$

$\Rightarrow f'(1) = F(1) + F'(1) < 0$

[given $F(1) = 0$ and $F'(x) < 0$]

Also, $f(2) = 2F(2) < 0$ [using $F(x) < 0, \forall x \in (1, 3)$]

Now, $f'(x) = F(x) + xF'(x) < 0$

[using $F(x) < 0, \forall x \in (1, 3)$]

$\Rightarrow f'(x) < 0$

45. Given, $\int_1^3 x^2 F'(x) dx = -12$

$\Rightarrow [x^2 F(x)]_1^3 - \int_1^3 2x \cdot F(x) dx = -12$

$\Rightarrow 9F(3) - F(1) - 2 \int_1^3 f(x) dx = -12$

[$\because xF(x) = f(x)$, given]

$\Rightarrow -36 - 0 - 2 \int_1^3 f(x) dx = -12$

$\therefore \int_1^3 f(x) dx = -12$ and $\int_1^3 x^3 F''(x) dx = 40$

$\Rightarrow [x^3 F'(x)]_1^3 - \int_1^3 3x^2 F'(x) dx = 40$

$\Rightarrow [x^2 (xF'(x))]_1^3 - 3 \times (-12) = 40$

$\Rightarrow \{x^2 \cdot [f'(x) - F(x)]\}_1^3 = 4$

$$\Rightarrow 9[f'(3) - F(3)] - [f'(1) - F(1)] = 4$$

$$\Rightarrow 9[f'(3) + 4] - [f'(1) - 0] = 4$$

$$\Rightarrow 9f'(3) - f'(1) = -32$$

$$46. \text{ Given, } \lim_{t \rightarrow a} \frac{\int_a^t f(x) dx - \frac{(t-a)}{2} \{f(t) + f(a)\}}{(t-a)^3} = 0$$

Using L'Hospital's rule, put $t - a = h$

$$\Rightarrow \lim_{h \rightarrow 0} \frac{\int_a^{a+h} f(x) dx - \frac{h}{2} \{f(a+h) + f(a)\}}{h^3} = 0$$

$$\Rightarrow \lim_{h \rightarrow 0} \frac{f(a+h) - \frac{1}{2} \{f(a+h) + f(a)\} - \frac{h}{2} \{f'(a+h)\}}{3h^2} = 0$$

Again, using L'Hospital's rule,

$$\lim_{h \rightarrow 0} \frac{f'(a+h) - \frac{1}{2} f'(a+h) - \frac{1}{2} f'(a+h) - \frac{h}{2} f''(a+h)}{6h} = 0$$

$$\Rightarrow \lim_{h \rightarrow 0} \frac{-\frac{h}{2} f''(a+h)}{6h} = 0 \Rightarrow f''(a) = 0, \forall a \in R$$

$\Rightarrow f(x)$ must have maximum degree 1.

$$47. F'(c) = (b-a)f'(c) + f(a) - f(b)$$

$$F''(c) = f''(c)(b-a) < 0$$

$$\Rightarrow F'(c) = 0 \Rightarrow f'(c) = \frac{f(b) - f(a)}{b-a}$$

$$48. \int_0^{\pi/2} \sin x dx = \frac{\pi-0}{4} \left[\sin 0 + \sin\left(\frac{\pi}{2}\right) + 2 \sin\left(\frac{0+\frac{\pi}{2}}{2}\right) \right]$$

$$= \frac{\pi}{8} (1 + \sqrt{2})$$

$$49. \because e^x \in (1, e) \text{ in } (0, 1) \text{ and } \int_0^x f(t) \sin t dt \in (0, 1) \text{ in } (0, 1)$$

$$\therefore e^x - \int_0^x f(t) \sin t dt \text{ cannot be zero.}$$

So, option (a) is incorrect.

$$(b) f(x) + \int_0^{\frac{\pi}{2}-x} f(t) \sin t dt \text{ always positive}$$

\therefore Option (b) is incorrect.

$$(c) \text{ Let } h(x) = x - \int_0^{\frac{\pi}{2}-x} f(t) \cos t dt,$$

$$h(0) = -\int_0^{\frac{\pi}{2}} f(t) \cos t dt < 0$$

$$h(1) = 1 - \int_0^{\frac{\pi}{2}-1} f(t) \cos t dt > 0$$

\therefore Option (c) is correct.

$$(d) \text{ Let } g(x) = x^9 - f(x)$$

$$g(0) = -f(0) < 0$$

$$g(1) = 1 - f(1) > 0$$

\therefore Option (d) is correct.

$$50. I = \sum_{k=1}^{98} \int_k^{k+1} \frac{(k+1)}{x(x+1)} dx$$

$$\text{Clearly, } I > \sum_{k=1}^{98} \int_k^{k+1} \frac{(k+1)}{(x+1)^2} dx$$

$$\Rightarrow I > \sum_{k=1}^{98} (k+1) \int_k^{k+1} \frac{1}{(x+1)^2} dx$$

$$\Rightarrow I > \sum_{k=1}^{98} (-(k+1)) \left[\frac{1}{k+2} - \frac{1}{k+1} \right] \Rightarrow I > \sum_{k=1}^{98} \frac{1}{k+2}$$

$$\Rightarrow I > \frac{1}{3} + \dots + \frac{1}{100} > \frac{98}{100} \Rightarrow I > \frac{49}{50}$$

$$\text{Also, } I < \sum_{k=1}^{98} \int_k^{k+1} \frac{k+1}{x(k+1)} dx = \sum_{k=1}^{98} [\log_e(k+1) - \log_e k]$$

$$I < \log_e 99$$

$$51. \text{ Here, } f(x) = 7 \tan^8 x + 7 \tan^6 x - 3 \tan^4 x - 3 \tan^2 x$$

$$\text{for all } x \in \left(-\frac{\pi}{2}, \frac{\pi}{2} \right)$$

$$\therefore f(x) = 7 \tan^6 x \sec^2 x - 3 \tan^2 x \sec^2 x$$

$$= (7 \tan^6 x - 3 \tan^2 x) \sec^2 x$$

$$\text{Now, } \int_0^{\pi/4} x f(x) dx = \int_0^{\pi/4} x (7 \tan^6 x - 3 \tan^2 x) \sec^2 x dx$$

$$= [x(\tan^7 x - \tan^3 x)]_0^{\pi/4}$$

$$- \int_0^{\pi/4} 1(\tan^7 x - \tan^3 x) dx$$

$$= 0 - \int_0^{\pi/4} \tan^3 x (\tan^4 x - 1) dx$$

$$= - \int_0^{\pi/4} \tan^3 x (\tan^2 x - 1) \sec^2 x dx$$

$$\text{Put } \tan x = t \Rightarrow \sec^2 x dx = dt$$

$$\therefore \int_0^{\pi/4} x f(x) dx = - \int_0^1 t^3 (t^2 - 1) dt$$

$$= \int_0^1 (t^3 - t^5) dt = \left[\frac{t^4}{4} - \frac{t^6}{6} \right]_0^1 = \frac{1}{4} - \frac{1}{6} = \frac{1}{12}$$

$$\text{Also, } \int_0^{\pi/4} f(x) dx = \int_0^{\pi/4} (7 \tan^6 x - 3 \tan^2 x) \sec^2 x dx$$

$$= \int_0^1 (7t^6 - 3t^2) dt$$

$$= [t^7 - t^3]_0^1 = 0$$

$$52. \text{ Here, } f'(x) = \frac{192x^3}{2 + \sin^4 \pi x} \therefore \frac{192x^3}{3} \leq f'(x) \leq \frac{192x^3}{2}$$

On integrating between the limits $\frac{1}{2}$ to x , we get

$$\int_{1/2}^x \frac{192x^3}{3} dx \leq \int_{1/2}^x f'(x) dx \leq \int_{1/2}^x \frac{192x^3}{2} dx$$

312 Definite Integration

$$\Rightarrow \frac{192}{12} \left(x^4 - \frac{1}{16} \right) \leq f(x) - f(0) \leq 24x^4 - \frac{3}{2}$$

$$\Rightarrow 16x^4 - 1 \leq f(x) \leq 24x^4 - \frac{3}{2}$$

Again integrating between the limits $\frac{1}{2}$ to 1, we get

$$\int_{1/2}^1 (16x^4 - 1) dx \leq \int_{1/2}^1 f(x) dx \leq \int_{1/2}^1 \left(24x^4 - \frac{3}{2} \right) dx$$

$$\Rightarrow \left[\frac{16x^5}{5} - x \right]_{1/2}^1 \leq \int_{1/2}^1 f(x) dx \leq \left[\frac{24x^5}{5} - \frac{3}{2}x \right]_{1/2}^1$$

$$\Rightarrow \left(\frac{11}{5} + \frac{2}{5} \right) \leq \int_{1/2}^1 f(x) dx \leq \left(\frac{33}{10} + \frac{6}{10} \right)$$

$$\Rightarrow 2.6 \leq \int_{1/2}^1 f(x) dx \leq 3.9$$

(*) None of the option is correct.

53. Let $I_1 = \int_0^{4\pi} e^t (\sin^6 at + \cos^4 at) dt$

$$\begin{aligned} &= \int_0^\pi e^t (\sin^6 at + \cos^4 at) dt \\ &\quad + \int_\pi^{2\pi} e^t (\sin^6 at + \cos^4 at) dt \\ &\quad + \int_{2\pi}^{3\pi} e^t (\sin^6 at + \cos^4 at) dt \\ &\quad + \int_{3\pi}^{4\pi} e^t (\sin^6 at + \cos^4 at) dt \end{aligned}$$

$$\therefore I_1 = I_2 + I_3 + I_4 + I_5 \quad \dots(i)$$

Now, $I_3 = \int_\pi^{2\pi} e^t (\sin^6 at + \cos^4 at) dt$

Put $t = \pi + x \Rightarrow dt = dx$

$$\therefore I_3 = \int_0^\pi e^{\pi+x} \cdot (\sin^6 at + \cos^4 at) dt = e^\pi \cdot I_2 \quad \dots(ii)$$

Now, $I_4 = \int_{2\pi}^{3\pi} e^t (\sin^6 at + \cos^4 at) dt$

Put $t = 2\pi + x \Rightarrow dt = dx$

$$\therefore I_4 = \int_0^\pi e^{x+2\pi} (\sin^6 at + \cos^4 at) dt = e^{2\pi} \cdot I_2 \quad \dots(iii)$$

and $I_5 = \int_{3\pi}^{4\pi} e^t (\sin^6 at + \cos^4 at) dt$

Put $t = 3\pi + x$

$$\therefore I_5 = \int_0^\pi e^{3\pi+x} (\sin^6 at + \cos^4 at) dt = e^{3\pi} \cdot I_2 \quad \dots(iv)$$

From Eqs. (i), (ii), (iii) and (iv), we get

$$I_1 = I_2 + e^\pi \cdot I_2 + e^{2\pi} \cdot I_2 + e^{3\pi} \cdot I_2 = (1 + e^\pi + e^{2\pi} + e^{3\pi}) I_2$$

$$\begin{aligned} \therefore L &= \frac{\int_0^{4\pi} e^t (\sin^6 at + \cos^4 at) dt}{\int_0^\pi e^t (\sin^6 at + \cos^4 at) dt} \\ &= (1 + e^\pi + e^{2\pi} + e^{3\pi}) = \frac{1 \cdot (e^{4\pi} - 1)}{e^\pi - 1} \text{ for } a \in R \end{aligned}$$

54. Let $I = \int_0^1 \frac{x^4 (1-x)^4}{1+x^2} dx = \int_0^1 \frac{(x^4-1)(1-x)^4 + (1-x)^4}{(1+x^2)} dx$

$$= \int_0^1 (x^2-1)(1-x)^4 dx + \int_0^1 \frac{(1+x^2-2x)^2}{(1+x^2)} dx$$

$$= \int_0^1 \left\{ (x^2-1)(1-x)^4 + (1+x^2) - 4x + \frac{4x^2}{(1+x^2)} \right\} dx$$

$$= \int_0^1 \left((x^2-1)(1-x)^4 + (1+x^2) - 4x + 4 - \frac{4}{1+x^2} \right) dx$$

$$= \int_0^1 \left(x^6 - 4x^5 + 5x^4 - 4x^2 + 4 - \frac{4}{1+x^2} \right) dx$$

$$= \left[\frac{x^7}{7} - \frac{4x^6}{6} + \frac{5x^5}{5} - \frac{4x^3}{3} + 4x - 4 \tan^{-1} x \right]_0^1$$

$$= \frac{1}{7} - \frac{4}{6} + \frac{5}{5} - \frac{4}{3} + 4 - 4 \left(\frac{\pi}{4} - 0 \right) = \frac{22}{7} - \pi$$

55. Given $I_n = \int_{-\pi}^\pi \frac{\sin nx}{(1+\pi^x) \sin x} dx \quad \dots(i)$

Using $\int_a^b f(x) dx = \int_a^b f(b+a-x) dx$, we get

$$I_n = \int_{-\pi}^\pi \frac{\pi^x \sin nx}{(1+\pi^x) \sin x} dx \quad \dots(ii)$$

On adding Eqs. (i) and (ii), we have

$$2I_n = \int_{-\pi}^\pi \frac{\sin nx}{\sin x} dx = 2 \int_0^\pi \frac{\sin nx}{\sin x} dx$$

$$[\because f(x) = \frac{\sin nx}{\sin x} \text{ is an even function}]$$

$$\Rightarrow I_n = \int_0^\pi \frac{\sin nx}{\sin x} dx$$

Now, $I_{n+2} - I_n = \int_0^\pi \frac{\sin(n+2)x - \sin nx}{\sin x} dx$

$$= \int_0^\pi \frac{\pi^2 \cos(n+1)x \cdot \sin x}{\sin x} dx$$

$$= 2 \int_0^\pi \cos(n+1)x dx = 2 \left[\frac{\sin(n+1)x}{(n+1)} \right]_0^\pi = 0$$

$$\therefore I_{n+2} = I_n \quad \dots(iii)$$

Since, $I_n = \int_0^\pi \frac{\sin nx}{\sin x} dx \Rightarrow I_1 = \pi$ and $I_2 = 0$

From Eq. (iii) $I_1 = I_3 = I_5 = \dots = \pi$

and $I_2 = I_4 = I_6 = \dots = 0$

$$\Rightarrow \sum_{m=1}^{10} I_{2m+1} = 10\pi \quad \text{and} \quad \sum_{m=1}^{10} I_{2m} = 0$$

\therefore Correct options are (a), (b), (c).

56. The integral, $I = \int_1^2 |2x - [3x]| dx$

$$= \int_1^{4/3} |2x-3| dx + \int_{4/3}^{5/3} |2x-4| dx + \int_1^2 |2x-5| dx$$

$$= \int_1^{4/3} (3-2x) dx + \int_{4/3}^{5/3} (4-2x) dx + \int_{5/3}^2 (5-2x) dx$$

$$= [3x - x^2]_1^{4/3} + [4x - x^2]_{4/3}^{5/3} + [5x - x^2]_{5/3}^2$$

$$= \left(4 - \frac{16}{9} - 3 + 1 \right) + \left(\frac{20}{3} - \frac{25}{9} - \frac{16}{3} + \frac{16}{9} \right)$$

$$+ \left(10 - 4 - \frac{25}{3} + \frac{25}{9} \right)$$

$$= (2+6) + \left(\frac{20}{3} - \frac{16}{3} - \frac{25}{3}\right) + \left(-\frac{16}{9} - \frac{25}{9} + \frac{16}{9} + \frac{25}{9}\right)$$

$$= 8 - \frac{21}{3} = 8 - 7 = 1$$

Hence, answer 1.00 is correct.

57. Key Idea Use property $\int_0^a f(x) dx = \int_0^a f(a-x) dx$

The given integral

$$I = \int_0^{\pi/2} \frac{3\sqrt{\cos\theta}}{(\sqrt{\cos\theta} + \sqrt{\sin\theta})^5} d\theta \quad \dots (i)$$

$$\Rightarrow I = \int_0^{\pi/2} \frac{3\sqrt{\sin\theta}}{(\sqrt{\sin\theta} + \sqrt{\cos\theta})^5} d\theta \quad \dots (ii)$$

$$[\text{Using the property } \int_0^a f(x) dx = \int_0^a f(a-x) dx]$$

Now, on adding integrals (i) and (ii), we get

$$2I = \int_0^{\pi/2} \frac{3}{(\sqrt{\sin\theta} + \sqrt{\cos\theta})^4} d\theta$$

$$= \int_0^{\pi/2} \frac{3\sec^2\theta}{(1 + \sqrt{\tan\theta})^4} d\theta$$

Now, let $\tan\theta = t^2 \Rightarrow \sec^2\theta d\theta = 2t dt$

and at $\theta = \frac{\pi}{2}, t \rightarrow \infty$

and at $\theta = 0, t \rightarrow 0$

$$\text{So, } 2I = \int_0^\infty \frac{6t dt}{(1+t^2)^4} = 6 \int_0^\infty \frac{t+1-1}{(t+1)^4} dt$$

\Rightarrow

$$I = 3 \left[\int_0^\infty \frac{dt}{(t+1)^3} - \int_0^\infty \frac{dt}{(t+1)^4} \right] = 3 \left[-\frac{1}{2(t+1)^2} + \frac{1}{3(t+1)^3} \right]_0^\infty$$

$$\Rightarrow I = 3 \left[\frac{1}{2} - \frac{1}{3} \right] = 3 \left(\frac{1}{6} \right) = \frac{1}{2} \Rightarrow I = 0.5$$

58. Given, $I = \frac{2}{\pi} \int_{-\pi/4}^{\pi/4} \frac{dx}{(1 + e^{\sin x})(2 - \cos 2x)}$... (i)

On applying property $\int_a^b f(x) dx = \int_a^b f(a+b-x) dx$,

we get

$$I = \frac{2}{\pi} \int_{-\pi/4}^{\pi/4} \frac{e^{\sin x} dx}{(1 + e^{\sin x})(2 - \cos 2x)} \quad \dots (ii)$$

On adding integrals (i) and (ii), we get

$$2I = \frac{2}{\pi} \int_{-\pi/4}^{\pi/4} \frac{dx}{2 - \cos 2x}$$

$$\Rightarrow I = \frac{1}{\pi} \int_{-\pi/4}^{\pi/4} \frac{dx}{2 - \frac{1 - \tan^2 x}{1 + \tan^2 x}} \quad \left[\text{as } \cos 2x = \frac{1 - \tan^2 x}{1 + \tan^2 x} \right]$$

$$= \frac{2}{\pi} \int_0^{\pi/4} \frac{\sec^2 x}{1 + 3 \tan^2 x} dx$$

$$\left[\because \frac{\sec^2 x}{1 + 3 \tan^2 x} \text{ is even function} \right]$$

Put $\sqrt{3} \tan x = t \Rightarrow \sqrt{3} \sec^2 x dx = dt$, and at $x=0, t=0$ and at $x = \sqrt{3}, t = \sqrt{3}$

$$\text{So, } I = \frac{2}{\pi} \int_0^{\sqrt{3}} \frac{1}{\sqrt{3}} \frac{dt}{1+t^2} = \frac{2}{\sqrt{3}\pi} [\tan^{-1} t]_0^{\sqrt{3}}$$

$$= \frac{2}{\sqrt{3}\pi} \left(\frac{\pi}{3} \right) = \frac{2}{3\sqrt{3}} \Rightarrow 27I^2 = 4.00$$

59. Let $I = \int_0^{1/2} \frac{1 + \sqrt{3}}{[(x+1)^2(1-x)^6]^{1/4}} dx$

$$\Rightarrow I = \int_0^{1/2} \frac{1 + \sqrt{3}}{(1-x)^2 \left[\left(\frac{1-x}{1+x} \right)^6 \right]^{1/4}} dx$$

$$\text{Put } \frac{1-x}{1+x} = t \Rightarrow \frac{-2 dx}{(1+x)^2} = dt$$

when $x=0, t=1, x=\frac{1}{2}, t=\frac{1}{3}$

$$\therefore I = \int_1^{1/3} \frac{(1 + \sqrt{3}) dt}{-2(t)^{6/4}}$$

$$\Rightarrow I = \frac{-(1 + \sqrt{3})}{2} \left[\frac{-2}{\sqrt{t}} \right]_1^{1/3}$$

$$\Rightarrow I = (1 + \sqrt{3})(\sqrt{3} - 1)$$

$$\Rightarrow I = 3 - 1 = 2$$

60. Here, $f(x) = \begin{cases} [x], & x \leq 2 \\ 0, & x > 2 \end{cases}$

$$\therefore I = \int_{-1}^2 \frac{x f(x^2)}{2 + f(x+1)} dx$$

$$= \int_{-1}^0 \frac{x f(x^2)}{2 + f(x+1)} dx + \int_0^1 \frac{x f(x^2)}{2 + f(x+1)} dx$$

$$+ \int_1^{\sqrt{2}} \frac{x f(x^2)}{2 + f(x+1)} dx + \int_{\sqrt{2}}^{\sqrt{3}} \frac{x f(x^2)}{2 + f(x+1)} dx$$

$$+ \int_{\sqrt{3}}^2 \frac{x f(x^2)}{2 + f(x+1)} dx$$

$$= \int_{-1}^0 0 dx + \int_0^1 0 dx + \int_1^{\sqrt{2}} \frac{x \cdot 1}{2+0} dx$$

$$+ \int_{\sqrt{2}}^{\sqrt{3}} 0 dx + \int_{\sqrt{3}}^2 0 dx$$

$$\left[\begin{array}{l} \because -1 < x < 0 \Rightarrow 0 < x^2 < 1 \Rightarrow [x^2] = 0, \\ 0 < x < 1 \Rightarrow 0 < x^2 < 1 \Rightarrow [x^2] = 0, \\ 1 < x < \sqrt{2} \Rightarrow \begin{cases} 1 < x^2 < 2 \Rightarrow [x^2] = 1 \\ 2 < x+1 < 1 + \sqrt{2} \Rightarrow f(x+1) = 0, \end{cases} \\ \sqrt{2} < x < \sqrt{3} \Rightarrow 2 < x^2 < 3 \Rightarrow f(x^2) = 0, \\ \text{and } \sqrt{3} < x < 2 \Rightarrow 3 < x^2 < 4 \Rightarrow f(x^2) = 0 \end{array} \right]$$

$$\Rightarrow I = \int_1^{\sqrt{2}} \frac{x}{2} dx = \left[\frac{x^2}{4} \right]_1^{\sqrt{2}} = \frac{1}{4} (2 - 1) = \frac{1}{4}$$

$$\therefore 4I = 1 \Rightarrow 4I - 1 = 0$$

314 Definite Integration

61. Here, $\alpha = \int_0^1 e^{(9x+3 \tan^{-1} x)} \left(\frac{12+9x^2}{1+x^2} \right) dx$

Put $9x+3 \tan^{-1} x = t$

$\Rightarrow \left(9 + \frac{3}{1+x^2} \right) dx = dt$

$\therefore \alpha = \int_0^{9+3\pi/4} e^t dt = [e^t]_0^{9+3\pi/4} = e^{9+3\pi/4} - 1$

$\Rightarrow \log_e |1 + \alpha| = 9 + \frac{3\pi}{4} \Rightarrow \log_e |\alpha + 1| - \frac{3\pi}{4} = 9$

62. **PLAN** Integration by parts

$$\int f(x) g(x) dx = f(x) \int g(x) dx - \int \left(\frac{d}{dx} [f(x)] \int g(x) dx \right) dx$$

Given, $I = \int_0^1 4x^3 \frac{d^2}{dx^2} (1-x^2)^5 dx$

$$= \left[4x^3 \frac{d}{dx} (1-x^2)^5 \right]_0^1 - \int_0^1 12x^2 \frac{d}{dx} (1-x^2)^5 dx$$

$$= \left[4x^3 \times 5(1-x^2)^4 (-2x) \right]_0^1 - 12 \left[x^2 (1-x^2)^5 \right]_0^1 - \int_0^1 2x(1-x^2)^5 dx$$

$$= 0 - 0 - 12(0-0) + 12 \int_0^1 2x(1-x^2)^5 dx$$

$$= 12 \times \left[-\frac{(1-x^2)^6}{6} \right]_0^1 = 12 \left[0 + \frac{1}{6} \right] = 2$$

63. Given, $f(1) = \frac{1}{3}$ and $6 \int_1^x f(t) dt = 3x f(x) - x^3, \forall x \geq 1$

Using Newton-Leibnitz formula.

Differentiating both sides

$$\Rightarrow 6f(x) \cdot 1 - 0 = 3f(x) + 3xf'(x) - 3x^2$$

$$\Rightarrow 3xf'(x) - 3f(x) = 3x^2 \Rightarrow f'(x) - \frac{1}{x} f(x) = x$$

$$\Rightarrow \frac{xf'(x) - f(x)}{x^2} = 1$$

$$\Rightarrow \frac{d}{dx} \left[\frac{f(x)}{x} \right] = 1$$

On integrating both sides, we get

$$\Rightarrow \frac{f(x)}{x} = x + c \quad \left[\because f(1) = \frac{1}{3} \right]$$

$$\frac{1}{3} = 1 + c \Rightarrow c = \frac{2}{3} \text{ and } f(x) = x^2 - \frac{2}{3}x$$

$$\therefore f(2) = 4 - \frac{4}{3} = \frac{8}{3}$$

NOTE Here, $f(1) = 2$, does not satisfy given function.

$$\therefore f(1) = \frac{1}{3}$$

For that $f(x) = x^2 - \frac{2}{3}x$ and $f(2) = 4 - \frac{4}{3} = \frac{8}{3}$

64. Given, $\int_1^4 \frac{2e^{\sin x^2}}{x} dx = F(k) - F(1)$

Put $x^2 = t$

$\Rightarrow 2x dx = dt$

$$\Rightarrow \int_1^{16} 2 \frac{e^{\sin t}}{t} \cdot \frac{dt}{2} = F(k) - F(1)$$

$$\Rightarrow \int_1^{16} \frac{e^{\sin t}}{t} dt = F(k) - F(1)$$

$$\Rightarrow [F(t)]_1^{16} = F(k) - F(1)$$

$$\left[\because \frac{d}{dx} \{F(x)\} = \frac{e^{\sin x}}{x}, \text{ given} \right]$$

$$\Rightarrow F(16) - F(1) = F(k) - F(1)$$

$$\therefore k = 16$$

65. Let $I = \int_1^{37\pi} \frac{\pi \sin(\pi \log x)}{x} dx$

Put $\pi \log x = t$

$$\Rightarrow \frac{\pi}{x} dx = dt$$

$$\therefore I = \int_0^{37\pi} \sin(t) dt = -[\cos t]_0^{37\pi} = -[\cos 37\pi - \cos 0]$$

$$= -[(-1) - 1] = 2$$

66. Let $I = \int_0^{2\pi} \frac{x \sin^{2n} x}{\sin^{2n} x + \cos^{2n} x} dx$... (i)

$$I = \int_0^{2\pi} \frac{(2\pi - x) [\sin(2\pi - x)]^{2n}}{[\sin(2\pi - x)]^{2n} + [\cos(2\pi - x)]^{2n}} dx$$

$$\left[\because \int_0^a f(x) dx = \int_0^a f(a-x) dx \right]$$

$$I = \int_0^{2\pi} \frac{(2\pi - x) \cdot \sin^{2n} x}{\sin^{2n} x + \cos^{2n} x} dx$$

$$\Rightarrow I = \int_0^{2\pi} \frac{2\pi \sin^{2n} x}{\sin^{2n} x + \cos^{2n} x} dx - \int_0^{2\pi} \frac{x \sin^{2n} x}{\sin^{2n} x + \cos^{2n} x} dx$$

$$\Rightarrow I = \int_0^{2\pi} \frac{2\pi \sin^{2n} x}{\sin^{2n} x + \cos^{2n} x} dx - I \quad \text{[from Eq. (i)]}$$

$$\Rightarrow I = \int_0^{2\pi} \frac{\pi \sin^{2n} x}{\sin^{2n} x + \cos^{2n} x} dx$$

$$\Rightarrow I = \pi \left[\int_0^{\pi} \frac{\pi \sin^{2n} x}{\sin^{2n} x + \cos^{2n} x} dx \right.$$

$$\left. + \int_0^{\pi} \frac{\sin^{2n}(2\pi - x)}{\sin^{2n}(2\pi - x) + \cos^{2n}(2\pi - x)} dx \right]$$

$$\left[\text{using property} \right. \\ \left. \int_0^{2a} f(x) dx = \int_0^a [f(x) + f(2a-x)] dx \right]$$

$$I = \pi \left[\int_0^{\pi} \frac{\sin^{2n} x dx}{\sin^{2n} x + \cos^{2n} x} dx \right.$$

$$\left. + \int_0^{\pi} \frac{\sin^{2n} x}{\sin^{2n} x + \cos^{2n} x} dx \right]$$

$$\Rightarrow I = 2\pi \int_0^{\pi} \frac{\sin^{2n} x dx}{\sin^{2n} x + \cos^{2n} x} dx$$

$$\Rightarrow I = 4\pi \left[\int_0^{\pi/2} \frac{\sin^{2n} x dx}{\sin^{2n} x + \cos^{2n} x} dx \right] \quad \dots \text{(ii)}$$

$$\Rightarrow I = 4\pi \int_0^{\pi/2} \frac{\sin^{2n}(\pi/2 - x)}{\sin^{2n}(\pi/2 - x) + \cos^{2n}(\pi/2 - x)} dx$$

$$\Rightarrow I = 4\pi \int_0^{\pi/2} \frac{\cos^{2n} x}{\cos^{2n} x + \sin^{2n} x} dx \quad \dots(\text{iii})$$

On adding Eqs. (ii) and (iii), we get

$$2I = 4\pi \int_0^{\pi/2} \frac{\sin^{2n} x + \cos^{2n} x}{\sin^{2n} x + \cos^{2n} x} dx$$

$$\Rightarrow 2I = 4\pi \int_0^{\pi/2} 1 dx = 4\pi [x]_0^{\pi/2} = 4\pi \cdot \frac{\pi}{2} \Rightarrow I = \pi^2$$

67. Given, $af(x) + bf(1/x) = \frac{1}{x} - 5$... (i)

Replacing x by $1/x$ in Eq. (i), we get

$$af(1/x) + bf(x) = x - 5 \quad \dots(\text{ii})$$

On multiplying Eq. (i) by a and Eq. (ii) by b , we get

$$a^2 f(x) + abf(1/x) = a \left(\frac{1}{x} - 5 \right) \quad \dots(\text{iii})$$

$$abf(1/x) + b^2 f(x) = b(x - 5) \quad \dots(\text{iv})$$

On subtracting Eq. (iv) from Eq. (iii), we get

$$(a^2 - b^2) f(x) = \frac{a}{x} - bx - 5a + 5b$$

$$\Rightarrow f(x) = \frac{1}{(a^2 - b^2)} \left(\frac{a}{x} - bx - 5a + 5b \right)$$

$$\begin{aligned} \Rightarrow \int_1^2 f(x) dx &= \frac{1}{(a^2 - b^2)} \int_1^2 \left(\frac{a}{x} - bx - 5a + 5b \right) dx \\ &= \frac{1}{(a^2 - b^2)} \left[a \log |x| - \frac{b}{2} x^2 - 5(a - b)x \right]_1^2 \\ &= \frac{1}{(a^2 - b^2)} \left[a \log 2 - 2b - 10(a - b) \right. \\ &\quad \left. - a \log 1 + \frac{b}{2} + 5(a - b) \right] \\ &= \frac{1}{(a^2 - b^2)} \left[a \log 2 - 5a + \frac{7}{2} b \right] \end{aligned}$$

68. Let $I = \int_2^3 \frac{\sqrt{x}}{\sqrt{5-x} + \sqrt{x}} dx$... (i)

$$\Rightarrow I = \int_2^3 \frac{\sqrt{2+3-x}}{\sqrt{(2+3)-(5-x)} + \sqrt{2+3-x}} dx$$

$$\Rightarrow I = \int_2^3 \frac{\sqrt{5-x}}{\sqrt{x} + \sqrt{5-x}} dx \quad \dots(\text{ii})$$

On adding Eqs. (i) and (ii), we get

$$2I = \int_2^3 \frac{\sqrt{x} + \sqrt{5-x}}{\sqrt{5-x} + \sqrt{x}} dx \Rightarrow 2I = \int_2^3 1 dx = 1 \Rightarrow I = \frac{1}{2}$$

69. Let $I = \int_{\pi/4}^{3\pi/4} \frac{x}{1 + \sin x} dx$... (i)

$$\Rightarrow I = \int_{\pi/4}^{3\pi/4} \frac{\left(\frac{\pi}{4} + \frac{3\pi}{4} - x \right)}{1 + \sin \left(\frac{\pi}{4} + \frac{3\pi}{4} - x \right)} dx$$

$$[\because \int_a^b f(x) dx = \int_a^b f(a+b-x) dx]$$

$$\begin{aligned} &= \int_{\pi/4}^{3\pi/4} \frac{\pi - x}{1 + \sin(\pi - x)} dx \\ &= \int_{\pi/4}^{3\pi/4} \frac{\pi}{1 + \sin x} dx - \int_{\pi/4}^{3\pi/4} \frac{x}{1 + \sin x} dx \\ &= \pi \int_{\pi/4}^{3\pi/4} \frac{dx}{1 + \sin x} - I \quad \text{[from Eq. (i)]} \\ &= \frac{\pi}{2} \int_{\pi/4}^{3\pi/4} \frac{dx}{(1 + \sin x)} \\ &= \frac{\pi}{2} \int_{\pi/4}^{3\pi/4} \frac{(1 - \sin x)}{(1 + \sin x)(1 - \sin x)} dx \\ &= \frac{\pi}{2} \int_{\pi/4}^{3\pi/4} \frac{(1 - \sin x)}{1 - \sin^2 x} dx \\ &= \frac{\pi}{2} \int_{\pi/4}^{3\pi/4} \left(\frac{1}{\cos^2 x} - \frac{\sin x}{\cos^2 x} \right) dx \\ &= \frac{\pi}{2} \int_{\pi/4}^{3\pi/4} (\sec^2 x - \sec x \cdot \tan x) dx \\ &= \frac{\pi}{2} [\tan x - \sec x]_{\pi/4}^{3\pi/4} \\ &= \frac{\pi}{2} [-1 - 1 - (-\sqrt{2} - \sqrt{2})] \\ &= \frac{\pi}{2} (-2 + 2\sqrt{2}) = \pi(\sqrt{2} - 1) \end{aligned}$$

70. $\int_{-2}^2 |1 - x^2| dx$

$$\begin{aligned} &= \int_{-2}^{-1} (x^2 - 1) dx + \int_{-1}^1 (1 - x^2) dx + \int_1^2 (x^2 - 1) dx \\ &= \left[\frac{x^3}{3} - x \right]_{-2}^{-1} + \left[x - \frac{x^3}{3} \right]_{-1}^1 + \left[\frac{x^3}{3} - x \right]_1^2 \\ &= \left(-\frac{1}{3} + 1 + \frac{8}{3} - 2 \right) + \left(1 - \frac{1}{3} + 1 - \frac{1}{3} \right) + \left(\frac{8}{3} - 2 - \frac{1}{3} + 1 \right) \\ &= 4 \end{aligned}$$

71. $\int_0^{1.5} [x^2] dx = \int_0^1 0 dx + \int_1^{\sqrt{2}} 1 dx + \int_{\sqrt{2}}^{1.5} 2 dx$

$$\begin{aligned} &= 0 + [x]_1^{\sqrt{2}} + 2[x]_{\sqrt{2}}^{1.5} \\ &= (\sqrt{2} - 1) + 2(1.5 - \sqrt{2}) \\ &= \sqrt{2} - 1 + 3 - 2\sqrt{2} = 2 - \sqrt{2} \end{aligned}$$

72. (A) Let $I = \int_{-1}^1 \frac{dx}{1+x^2}$

Put $x = \tan \theta$

$$\Rightarrow dx = \sec^2 \theta d\theta$$

$$\therefore I = 2 \int_0^{\pi/4} d\theta = \frac{\pi}{2}$$

(B) Let $I = \int_0^1 \frac{dx}{\sqrt{1-x^2}}$

Put $x = \sin \theta$

$$\Rightarrow dx = \cos \theta d\theta$$

$$\therefore I = \int_0^{\pi/2} 1 d\theta = \frac{\pi}{2}$$

316 Definite Integration

$$(C) \int_2^3 \frac{dx}{1-x^2} = \frac{1}{2} \left[\log \left(\frac{1+x}{1-x} \right) \right]_2^3$$

$$= \frac{1}{2} \left[\log \left(\frac{4}{-2} \right) - \log \left(\frac{3}{-1} \right) \right] = \frac{1}{2} \left[\log \left(\frac{2}{3} \right) \right]$$

$$(D) \int_1^2 \frac{dx}{x\sqrt{x^2-1}} = [\sec^{-1} x]_1^2 = \frac{\pi}{3} - 0 = \frac{\pi}{3}$$

73. (P) **PLAN** (i) A polynomial satisfying the given conditions is taken.
 (ii) The other conditions are also applied and the number of polynomial is taken out.

Let $f(x) = ax^2 + bx + c$
 $f(0) = 0 \Rightarrow c = 0$

Now, $\int_0^1 f(x) dx = 1$
 $\Rightarrow \left(\frac{ax^3}{3} + \frac{bx^2}{2} \right)_0^1 = 1 \Rightarrow \frac{\alpha}{3} + \frac{\beta}{2} = 1$

$\Rightarrow 2a + 3b = 6$

As a, b are non-negative integers.

So, $a = 0, b = 2$ or $a = 3, b = 0$

$\therefore f(x) = 2x$ or $f(x) = 3x^2$

- (Q) **PLAN** Such type of questions are converted into only sine or cosine expression and then the number of points of maxima in given interval are obtained.

$$f(x) = \sin(x^2) + \cos(x^2)$$

$$= \sqrt{2} \left[\frac{1}{\sqrt{2}} \cos(x^2) + \frac{1}{\sqrt{2}} \sin(x^2) \right]$$

$$= \sqrt{2} \left[\cos x^2 \cos \frac{\pi}{4} + \sin \frac{\pi}{4} \sin(x^2) \right]$$

$$= \sqrt{2} \cos \left(x^2 - \frac{\pi}{4} \right)$$

For maximum value, $x^2 - \frac{\pi}{4} = 2n\pi \Rightarrow x^2 = 2n\pi + \frac{\pi}{4}$

$\Rightarrow x = \pm \sqrt{\frac{\pi}{4}}$, for $n = 0 \Rightarrow x = \pm \sqrt{\frac{9\pi}{4}}$, for $n = 1$

So, $f(x)$ attains maximum at 4 points in $[-\sqrt{13}, \sqrt{13}]$.

(R) **PLAN**

(i) $\int_{-a}^a f(x) dx = \int_{-a}^a f(-x) dx$

- (ii) $\int_{-a}^a f(x) dx = 2 \int_0^a f(x) dx$, if $f(-x) = f(x)$, i.e. f is an even function.

$$I = \int_{-2}^2 \frac{3x^2}{1+e^x} dx$$

and $I = \int_{-2}^2 \frac{3x^2}{1+e^{-x}} dx$

$\Rightarrow 2I = \int_{-2}^2 \left(\frac{3x^2}{1+e^x} + \frac{3x^2(e^x)}{e^x+1} \right) dx$

$2I = \int_{-2}^2 3x^2 dx \Rightarrow 2I = 2 \int_0^2 3x^2 dx$

$I = [x^3]_0^2 = 8$

(S) **PLAN** $\int_{-a}^a f(x) dx = 0$

If $f(-x) = -f(x)$, i.e. $f(x)$ is an odd function.

Let $f(x) = \cos 2x \log \left(\frac{1+x}{1-x} \right)$

$f(-x) = \cos 2x \log \left(\frac{1-x}{1+x} \right) = -f(x)$

Hence, $f(x)$ is an odd function.

So, $\int_{-1/2}^{1/2} f(x) dx = 0$

(P) \rightarrow (ii); (Q) \rightarrow (iii); (R) \rightarrow (i); (S) \rightarrow (iv)

74. Let $I_2 = \int_0^1 (1-x^{50})^{101} dx$,

$= [(1-x^{50})^{101} \cdot x]_0^1 + \int_0^1 (1-x^{50})^{100} \cdot 50 \cdot x^{49} \cdot x dx$

[using integration by parts]

$= 0 - \int_0^1 (50)(101)(1-x^{50})^{100}(-x^{50}) dx$

$= - (50)(101) \int_0^1 (1-x^{50})^{101} dx$

$+ (50)(101) \int_0^1 (1-x^{50})^{100} dx = 5050I_2 + 5050I_1$

$\therefore I_2 + 5050I_2 = 5050I_1 \Rightarrow \frac{(5050)I_1}{I_2} = 5051$

75. Let

$I = \int_0^\pi e^{|\cos x|} \left(2 \sin \left(\frac{1}{2} \cos x \right) + 3 \cos \left(\frac{1}{2} \cos x \right) \right) \sin x dx$

$\Rightarrow I = \int_0^\pi e^{|\cos x|} \cdot \sin x \cdot 2 \sin \left(\frac{1}{2} \cos x \right) dx$

$+ \int_0^\pi e^{|\cos x|} \cdot 3 \cos \left(\frac{1}{2} \cos x \right) \cdot \sin x dx$

$\Rightarrow I = I_1 + I_2 \dots(i)$

$\left[\text{using } \int_0^{2a} f(x) dx = \begin{cases} 0, & f(2a-x) = -f(x) \\ 2 \int_0^a f(x) dx, & f(2a-x) = +f(x) \end{cases} \right]$

where, $I_1 = 0$ [$\because f(\pi-x) = -f(x)$] $\dots(ii)$

and $I_2 = 6 \int_0^{\pi/2} e^{\cos x} \cdot \sin x \cdot \cos \left(\frac{1}{2} \cos x \right) dx$

Now, $I_2 = 6 \int_0^1 e^t \cdot \cos \left(\frac{t}{2} \right) dt$

[put $\cos x = t \Rightarrow -\sin x dx = dt$]

$= 6 \left[e^t \cos \left(\frac{t}{2} \right) + \frac{1}{2} \int e^t \sin \frac{t}{2} dt \right]_0^1$

$= 6 \left[e^t \cos \left(\frac{t}{2} \right) + \frac{1}{2} \left(e^t \sin \frac{t}{2} - \int \frac{e^t}{2} \cos \frac{t}{2} dt \right) \right]_0^1$

$= 6 \left[e^t \cos \frac{t}{2} + \frac{1}{2} e^t \sin \frac{t}{2} \right]_0^1 - \frac{I_2}{4}$

$$= \frac{24}{5} \left[e \cos \left(\frac{1}{2} \right) + \frac{e}{2} \sin \left(\frac{1}{2} \right) - 1 \right] \quad \dots(\text{iii})$$

From Eq. (i), we get

$$I = \frac{24}{5} \left[e \cos \left(\frac{1}{2} \right) + \frac{e}{2} \sin \left(\frac{1}{2} \right) - 1 \right]$$

$$76. \text{ Let } I = \int_{-\pi/3}^{\pi/3} \frac{\pi dx}{2 - \cos \left(|x| + \frac{\pi}{3} \right)} + 4 \int_{-\pi/3}^{\pi/3} \frac{x^3 dx}{2 - \cos \left(|x| + \frac{\pi}{3} \right)}$$

$$\text{Using } \int_{-a}^a f(x) dx = \begin{cases} 0, & f(-x) = -f(x) \\ 2 \int_0^a f(x) dx, & f(-x) = f(x) \end{cases}$$

$$\therefore I = 2 \int_0^{\pi/3} \frac{\pi dx}{2 - \cos \left(|x| + \frac{\pi}{3} \right)} + 0 \left[\because \frac{x^3 dx}{2 - \cos \left(|x| + \frac{\pi}{3} \right)} \text{ is odd} \right]$$

$$I = 2\pi \int_0^{\pi/3} \frac{dx}{2 - \cos \left(x + \frac{\pi}{3} \right)}$$

$$\text{Put } x + \frac{\pi}{3} = t \Rightarrow dx = dt$$

$$\therefore I = 2\pi \int_{\pi/3}^{2\pi/3} \frac{dt}{2 - \cos t} = 2\pi \int_{\pi/3}^{2\pi/3} \frac{\sec^2 \frac{t}{2} dt}{1 + 3 \tan^2 \frac{t}{2}}$$

$$\text{Put } \tan \frac{t}{2} = u \Rightarrow \sec^2 \frac{t}{2} dt = 2 du$$

$$\Rightarrow I = 2\pi \int_{1/\sqrt{3}}^{\sqrt{3}} \frac{2 du}{1 + 3u^2} = \frac{4\pi}{3} [\sqrt{3} \tan^{-1} \sqrt{3}u]_{1/\sqrt{3}}^{\sqrt{3}}$$

$$= \frac{4\pi}{\sqrt{3}} (\tan^{-1} 3 - \tan^{-1} 1) = \frac{4\pi}{\sqrt{3}} \tan^{-1} \left(\frac{1}{2} \right)$$

$$\therefore \int_{-\pi/3}^{\pi/3} \frac{\pi + 4x^3}{2 - \cos \left(|x| + \frac{\pi}{3} \right)} dx = \frac{4\pi}{\sqrt{3}} \tan^{-1} \left(\frac{1}{2} \right)$$

$$77. \text{ Let } I = \int_0^{\pi/2} f(\cos 2x) \cos x dx \quad \dots(\text{i})$$

$$\Rightarrow I = \int_0^{\pi/2} f \left(\cos 2 \left(\frac{\pi}{2} - x \right) \right) \cdot \cos \left(\frac{\pi}{2} - x \right) dx$$

$$\left[\text{using } \int_0^a f(x) dx = \int_0^a f(a-x) dx \right]$$

$$\Rightarrow I = \int_0^{\pi/2} f(\cos 2x) \sin x dx \quad \dots(\text{ii})$$

On adding Eqs. (i) and (ii), we get

$$2I = \int_0^{\pi/2} f(\cos 2x) (\sin x + \cos x) dx$$

$$= \sqrt{2} \int_0^{\pi/2} f(\cos 2x) [\cos(x - \pi/4)] dx$$

$$\text{Put } -x + \frac{\pi}{4} = t \Rightarrow -dx = dt$$

$$\therefore 2I = -\sqrt{2} \int_{\pi/4}^{-\pi/4} f \left[\cos \left(\frac{\pi}{2} - 2t \right) \right] \cos t dt$$

$$\Rightarrow 2I = \sqrt{2} \int_{-\pi/4}^{\pi/4} f(\sin 2t) \cos t dt$$

$$\therefore I = \sqrt{2} \int_0^{\pi/4} f(\sin 2t) \cos t dt$$

$$78. \text{ Let } I = \int_0^{\pi} \frac{e^{\cos x}}{e^{\cos x} + e^{-\cos x}} dx \quad \dots(\text{i})$$

$$= \int_0^{\pi} \frac{e^{\cos(\pi-x)}}{e^{\cos(\pi-x)} + e^{-\cos(\pi-x)}} dx$$

$$\left[\because \int_0^a f(x) dx = \int_0^a f(a-x) dx \right]$$

$$\Rightarrow I = \int_0^{\pi} \frac{e^{-\cos x}}{e^{-\cos x} + e^{\cos x}} dx \quad \dots(\text{ii})$$

On adding Eqs. (i) and (ii), we get

$$= \int_0^{\pi} \frac{e^{\cos x} + e^{-\cos x}}{e^{\cos x} + e^{-\cos x}} dx = \int_0^{\pi} 1 dx = [x]_0^{\pi} = \pi$$

$$\Rightarrow I = \pi/2$$

$$79. \int_0^1 \tan^{-1} \left(\frac{1}{1-x+x^2} \right) dx = \int_0^1 \tan^{-1} \left[\frac{1-x+x}{1-x(1-x)} \right] dx$$

$$= \int_0^1 [\tan^{-1}(1-x) - \tan^{-1} x] dx$$

$$= \int_0^1 \tan^{-1}[1-(1-x)] dx + \int_0^1 \tan^{-1} x dx$$

$$= 2 \int_0^1 \tan^{-1} x dx \left[\because \int_0^a f(x) dx = \int_0^a f(a-x) dx \right] \dots(\text{i})$$

$$\text{Now, } \int_0^1 \tan^{-1} \left(\frac{1}{1-x+x^2} \right) dx$$

$$= \int_0^1 \left[\frac{\pi}{2} - \cot^{-1} \left(\frac{1}{1-x+x^2} \right) \right] dx$$

$$= \frac{\pi}{2} - \int_0^1 \tan^{-1}(1-x+x^2) dx$$

$$\therefore \int_0^1 \tan^{-1}(1-x+x^2) dx = \frac{\pi}{2} - \int_0^1 \tan^{-1} \frac{1}{(1-x+x^2)} dx$$

$$= \frac{\pi}{2} - 2I_1$$

$$\text{where, } I_1 = \int_0^1 \tan^{-1} x dx = [x \tan^{-1} x]_0^1 - \int_0^1 \frac{x dx}{1+x^2}$$

$$= \frac{\pi}{4} - \frac{1}{2} [\log(1+x^2)]_0^1 = \frac{\pi}{4} - \frac{1}{2} \log 2$$

$$\therefore \int_0^1 \tan^{-1}(1-x+x^2) dx = \frac{\pi}{2} - 2 \left(\frac{\pi}{4} - \frac{1}{2} \log 2 \right) = \log 2$$

$$80. \text{ Let } I = \int_0^{\pi/4} \log(1 + \tan x) dx \quad \dots(\text{i})$$

$$I = \int_0^{\pi/4} \log \left(1 + \tan \left(\frac{\pi}{4} - x \right) \right) dx$$

$$\therefore I = \int_0^{\pi/4} \log \left(1 + \frac{1 - \tan x}{1 + \tan x} \right) dx$$

318 Definite Integration

$$\begin{aligned}
 &= \int_0^{\pi/4} \log \left(\frac{1 + \tan x + 1 - \tan x}{1 + \tan x} \right) dx \\
 I &= \int_0^{\pi/4} \log \left(\frac{2}{1 + \tan x} \right) dx \Rightarrow I = \int_0^{\pi/4} \log 2 \, dx - I \\
 \Rightarrow 2I &= \frac{\pi}{4} \log 2 \Rightarrow I = \frac{\pi}{8} (\log 2)
 \end{aligned}$$

81. Let $I = \int_{-\pi}^{\pi} \frac{2x(1 + \sin x)}{1 + \cos^2 x} dx$

$$\begin{aligned}
 I &= \int_{-\pi}^{\pi} \frac{2x}{1 + \cos^2 x} dx + \int_{-\pi}^{\pi} \frac{2x \sin x}{1 + \cos^2 x} dx \\
 \Rightarrow I &= I_1 + I_2 \\
 \text{Now, } I_1 &= \int_{-\pi}^{\pi} \frac{2x}{1 + \cos^2 x} dx \\
 \text{Let } f(x) &= \frac{2x}{1 + \cos^2 x} \\
 \Rightarrow f(-x) &= \frac{-2x}{1 + \cos^2(-x)} = \frac{-2x}{1 + \cos^2 x} = -f(x) \\
 \Rightarrow f(-x) &= -f(x) \text{ which shows that } f(x) \text{ is an odd function.}
 \end{aligned}$$

$\therefore I_1 = 0$

Again, let $g(x) = \frac{2x \sin x}{1 + \cos^2 x}$

$$\begin{aligned}
 \Rightarrow g(-x) &= \frac{2(-x) \sin(-x)}{1 + \cos^2(-x)} = \frac{2x \sin x}{1 + \cos^2 x} = g(x) \\
 \Rightarrow g(-x) &= g(x) \text{ which shows that } g(x) \text{ is an even function.}
 \end{aligned}$$

$$\begin{aligned}
 \therefore I_2 &= \int_{-\pi}^{\pi} \frac{2x \sin x}{1 + \cos^2 x} dx = 2 \cdot 2 \int_0^{\pi} \frac{x \sin x}{1 + \cos^2 x} dx \\
 &= 4 \int_0^{\pi} \frac{\pi - x}{1 + [\cos(\pi - x)]^2} dx = 4 \int_0^{\pi} \frac{\pi - x}{1 + \cos^2 x} dx \\
 &= 4 \int_0^{\pi} \frac{\pi \sin x}{1 + \cos^2 x} dx - 4 \int_0^{\pi} \frac{x \sin x}{1 + \cos^2 x} dx \\
 \Rightarrow I_2 &= 4\pi \int_0^{\pi} \frac{\sin x}{1 + \cos^2 x} dx - I_2
 \end{aligned}$$

$$\Rightarrow 2I_2 = 4\pi \int_0^{\pi} \frac{\sin x}{1 + \cos^2 x} dx$$

Put $\cos x = t$

$$\begin{aligned}
 \Rightarrow -\sin x \, dx &= dt \\
 \therefore I_2 &= -2\pi \int_1^{-1} \frac{dt}{1 + t^2} = 2\pi \int_{-1}^1 \frac{dt}{1 + t^2} = 4\pi \int_0^1 \frac{dt}{1 + t^2} \\
 &= 4\pi [\tan^{-1} t]_0^1 = 4\pi [\tan^{-1} 1 - \tan^{-1} 0] \\
 &= 4\pi(\pi/4 - 0) = \pi^2 \\
 \therefore I &= I_1 + I_2 = 0 + \pi^2 = \pi^2
 \end{aligned}$$

82. Let $I = \int_{-1/\sqrt{3}}^{1/\sqrt{3}} \left(\frac{x^4}{1 - x^4} \right) \cos^{-1} \left(\frac{2x}{1 + x^2} \right) dx$... (i)

Put $x = -y \Rightarrow dx = -dy$

$$\therefore I = \int_{1/\sqrt{3}}^{-1/\sqrt{3}} \frac{y^4}{1 - y^4} \cos^{-1} \left(\frac{-2y}{1 + y^2} \right) (-1) dy$$

Now, $\cos^{-1}(-x) = \pi - \cos^{-1} x$ for $-1 \leq x \leq 1$.

$$\begin{aligned}
 \therefore I &= \int_{-1/\sqrt{3}}^{1/\sqrt{3}} \frac{y^4}{1 - y^4} \left[\pi - \cos^{-1} \left(\frac{2y}{1 + y^2} \right) \right] dy \\
 &= \pi \int_{-1/\sqrt{3}}^{1/\sqrt{3}} \frac{y^4}{1 - y^4} dy - \int_{-1/\sqrt{3}}^{1/\sqrt{3}} \frac{y^4}{1 - y^4} \cos^{-1} \left(\frac{2y}{1 + y^2} \right) dy \\
 &= \pi \int_{-1/\sqrt{3}}^{1/\sqrt{3}} \frac{x^4}{1 - x^4} dx - \int_{-1/\sqrt{3}}^{1/\sqrt{3}} \frac{x^4}{1 - x^4} \cos^{-1} \left(\frac{2x}{1 + x^2} \right) dx
 \end{aligned}$$

$$\Rightarrow I = \pi \int_{-1/\sqrt{3}}^{1/\sqrt{3}} \frac{x^4}{1 - x^4} dx - I \quad [\text{from Eq. (i)}]$$

$$\Rightarrow 2I = \pi \int_{-1/\sqrt{3}}^{1/\sqrt{3}} \frac{x^4}{1 - x^4} dx = \pi \int_{-1/\sqrt{3}}^{1/\sqrt{3}} \left[-1 + \frac{1}{1 - x^4} \right] dx$$

$$\begin{aligned}
 &= -\pi \int_{-1/\sqrt{3}}^{1/\sqrt{3}} 1 \, dx + \pi \int_{-1/\sqrt{3}}^{1/\sqrt{3}} \frac{dx}{1 - x^4} \\
 &= -\pi [x]_{-1/\sqrt{3}}^{1/\sqrt{3}} + \pi I_1, \text{ where } I_1 = \int_{-1/\sqrt{3}}^{1/\sqrt{3}} \frac{dx}{1 - x^4}
 \end{aligned}$$

$$\Rightarrow 2I = -\pi \left(\frac{1}{\sqrt{3}} + \frac{1}{\sqrt{3}} \right) + \pi I_1 = -\frac{2\pi}{\sqrt{3}} + \pi I_1$$

Now, $I_1 = \int_{-1/\sqrt{3}}^{1/\sqrt{3}} \frac{dx}{1 - x^4} = 2 \int_0^{1/\sqrt{3}} \frac{dx}{1 - x^4}$

[since, the integral is an even function]

$$\begin{aligned}
 &= \int_0^{1/\sqrt{3}} \frac{1 + 1 + x^2 - x^2}{(1 - x^2)(1 + x^2)} dx \\
 &= \int_0^{1/\sqrt{3}} \frac{1}{1 - x^2} dx + \int_0^{1/\sqrt{3}} \frac{1}{1 + x^2} dx \\
 &= \int_0^{1/\sqrt{3}} \frac{1}{(1 - x)(1 + x)} dx + \int_0^{1/\sqrt{3}} \frac{1}{(1 + x^2)} dx \\
 &= \frac{1}{2} \int_0^{1/\sqrt{3}} \frac{1}{1 - x} dx + \frac{1}{2} \int_0^{1/\sqrt{3}} \frac{1}{1 + x} dx + \int_0^{1/\sqrt{3}} \frac{1}{1 + x^2} dx \\
 &= \left[-\frac{1}{2} \ln |1 - x| + \frac{1}{2} \ln |1 + x| + \tan^{-1} x \right]_0^{1/\sqrt{3}}
 \end{aligned}$$

$$= \frac{1}{2} \left[\ln \left| \frac{1 + x}{1 - x} \right| \right]_0^{1/\sqrt{3}} + [\tan^{-1} x]_0^{1/\sqrt{3}}$$

$$= \frac{1}{2} \ln \left| \frac{1 + 1/\sqrt{3}}{1 - 1/\sqrt{3}} \right| + \tan^{-1} \frac{1}{\sqrt{3}}$$

$$= \frac{1}{2} \ln \left| \frac{\sqrt{3} + 1}{\sqrt{3} - 1} \right| + \frac{\pi}{6}$$

$$= \frac{1}{2} \ln \left| \frac{(\sqrt{3} + 1)^2}{3 - 1} \right| + \frac{\pi}{6}$$

$$= \frac{1}{2} \ln (2 + \sqrt{3}) + \frac{\pi}{6}$$

$$\begin{aligned}
 \therefore 2I &= \frac{-2\pi}{\sqrt{3}} + \frac{\pi}{2} \ln (2 + \sqrt{3}) + \frac{\pi^2}{6} \\
 &= \frac{\pi}{6} [\pi + 3 \ln (2 + \sqrt{3}) - 4\sqrt{3}]
 \end{aligned}$$

$$\Rightarrow I = \frac{\pi}{12} [\pi + 3 \ln(2 + \sqrt{3}) - 4\sqrt{3}]$$

Alternate Solution

$$\text{Since, } \cos^{-1} y = \frac{\pi}{2} - \sin^{-1} y$$

$$\therefore \cos^{-1}\left(\frac{2x}{1+x^2}\right) = \frac{\pi}{2} - \sin^{-1} \frac{2x}{1+x^2} = \frac{\pi}{2} - 2 \tan^{-1} x$$

$$I = \int_{-1/\sqrt{3}}^{1/\sqrt{3}} \left[\frac{\pi}{2} \cdot \frac{x^4}{1-x^4} - \frac{x^4}{1-x^4} 2 \tan^{-1} x \right] dx$$

$$\left[\because \frac{x^4}{1-x^4} 2 \tan^{-1} x \text{ is an odd function} \right]$$

$$\therefore I = 2 \cdot \frac{\pi}{2} \int_0^{1/\sqrt{3}} \left(-1 + \frac{1}{1-x^4} \right) dx + 0$$

$$= \frac{\pi}{2} \int_0^{1/\sqrt{3}} \left(-2 + \frac{1}{1-x^2} + \frac{1}{1+x^2} \right) dx$$

$$= \frac{\pi}{2} \left[-2x + \frac{1}{2 \cdot 1} \log \frac{1+x}{1-x} + \tan^{-1} x \right]_0^{1/\sqrt{3}}$$

$$= \frac{\pi}{2} \left[-\frac{2}{\sqrt{3}} + \frac{1}{2} \log \frac{\sqrt{3}+1}{\sqrt{3}-1} + \frac{\pi}{6} \right]$$

$$= \frac{\pi}{12} [\pi + 3 \log(2 + \sqrt{3}) - 4\sqrt{3}]$$

83. Let $I = \int_2^3 \frac{2x^5 + x^4 - 2x^3 + 2x^2 + 1}{(x^2 + 1)(x^4 - 1)} dx$

$$= \int_2^3 \frac{2x^5 - 2x^3 + x^4 + 1 + 2x^2}{(x^2 + 1)(x^2 - 1)(x^2 + 1)} dx$$

$$= \int_2^3 \frac{2x^3(x^2 - 1) + (x^2 + 1)^2}{(x^2 + 1)^2(x^2 - 1)} dx$$

$$= \int_2^3 \frac{2x^3(x^2 - 1)}{(x^2 + 1)^2(x^2 - 1)} dx + \int_2^3 \frac{(x^2 + 1)^2}{(x^2 + 1)^2(x^2 - 1)} dx$$

$$= \int_2^3 \frac{2x^3}{(x^2 + 1)^2} dx + \int_2^3 \frac{1}{x^2 - 1} dx$$

$$\Rightarrow I = I_1 + I_2$$

$$\text{Now, } I_1 = \int_2^3 \frac{2x^3}{(x^2 + 1)^2} dx$$

$$\text{Put } x^2 + 1 = t \Rightarrow 2x dx = dt$$

$$\therefore I_1 = \int_5^{10} \frac{(t-1)}{t^2} dt = \int_5^{10} \frac{1}{t} dt - \int_5^{10} \frac{1}{t^2} dt$$

$$= [\log t]_5^{10} + \left[\frac{1}{t} \right]_5^{10}$$

$$= \log 10 - \log 5 + \frac{1}{10} - \frac{1}{5} = \log 2 - \frac{1}{10}$$

$$\text{Again, } I_2 = \int_2^3 \frac{1}{x^2 - 1} dx = \int_2^3 \frac{1}{(x-1)(x+1)} dx$$

$$= \frac{1}{2} \int_2^3 \frac{1}{x-1} dx - \frac{1}{2} \int_2^3 \frac{1}{x+1} dx$$

$$= \left[\frac{1}{2} \log(x-1) \right]_2^3 - \frac{1}{2} \left[\log(x+1) \right]_2^3$$

$$= \frac{1}{2} \log \frac{2}{1} - \frac{1}{2} \log \frac{4}{3}$$

$$\text{From Eq. (i), } I = I_1 + I_2$$

$$= \log 2 - \frac{1}{10} + \frac{1}{2} \log 2 - \frac{1}{2} \log \frac{4}{3}$$

$$= \log [2 \cdot 2^{1/2} \left(\frac{4}{3}\right)^{-1/2}] - \frac{1}{10} = \frac{1}{2} \log 6 - \frac{1}{10}$$

84. Since, $f(x)$ is a cubic polynomial. Therefore, $f'(x)$ is a quadratic polynomial and $f(x)$ has relative maximum and minimum at $x = \frac{1}{3}$ and $x = -1$ respectively, therefore, -1 and $1/3$ are the roots of $f'(x) = 0$.

$$\therefore f'(x) = a(x+1) \left(x - \frac{1}{3} \right) = a \left(x^2 - \frac{1}{3}x + x - \frac{1}{3} \right)$$

$$= a \left(x^2 + \frac{2}{3}x - \frac{1}{3} \right)$$

Now, integrating w.r. t. x , we get

$$f(x) = a \left(\frac{x^3}{3} + \frac{x^2}{3} - \frac{x}{3} \right) + c$$

where, c is constant of integration.

$$\text{Again, } f(-2) = 0$$

$$\therefore f(-2) = a \left(-\frac{8}{3} + \frac{4}{3} + \frac{2}{3} \right) + c$$

$$\Rightarrow 0 = a \left(\frac{-8+4+2}{3} \right) + c$$

$$\Rightarrow 0 = \frac{-2a}{3} + c \Rightarrow c = \frac{2a}{3}$$

$$\therefore f(x) = a \left(\frac{x^3}{3} + \frac{x^2}{3} - \frac{x}{3} \right) + \frac{2a}{3} = \frac{a}{3} (x^3 + x^2 - x + 2)$$

$$\text{Again, } \int_{-1}^1 f(x) dx = \frac{14}{3} \quad [\text{given}]$$

$$\Rightarrow \int_{-1}^1 \frac{a}{3} (x^3 + x^2 - x + 2) dx = \frac{14}{3}$$

$$\Rightarrow \int_{-1}^1 \frac{a}{3} (0 + x^2 + 0 + 2) dx = \frac{14}{3}$$

[$\because y = x^3$ and $y = -x$ are odd functions]

$$\Rightarrow \frac{a}{3} \left[2 \int_0^1 x^2 dx + 4 \int_0^1 1 dx \right] = \frac{14}{3}$$

$$\Rightarrow \frac{a}{3} \left[\left(\frac{2x^3}{3} + 4x \right) \right]_0^1 = \frac{14}{3}$$

$$\Rightarrow \frac{a}{3} \left(\frac{2}{3} + 4 \right) = \frac{14}{3}$$

$$\Rightarrow \frac{a}{3} \left(\frac{14}{3} \right) = \frac{14}{3} \Rightarrow a = 3$$

$$\text{Hence, } f(x) = x^3 + x^2 - x + 2$$

320 Definite Integration

85. Let
$$I = \int_0^\pi \frac{x \sin(2x) \cdot \sin\left(\frac{\pi}{2} \cos x\right)}{(2x - \pi)} dx \quad \dots(i)$$

Then
$$I = \int_0^\pi \frac{(\pi - x) \cdot \sin 2(\pi - x) \cdot \sin\left[\frac{\pi}{2} \cos(\pi - x)\right]}{2(\pi - x) - \pi} dx \quad \dots(ii)$$

$$\Rightarrow I = \int_0^\pi \frac{(\pi - x) \cdot \sin 2x \cdot \sin\left(\frac{\pi}{2} \cos x\right)}{\pi - 2x} dx$$

$$\Rightarrow I = \int_0^\pi \frac{(x - \pi) \sin 2x \cdot \sin\left(\frac{\pi}{2} \cos x\right)}{(2x - \pi)} dx \quad \dots(iii)$$

On adding Eqs. (i) and (iii), we get

$$2I = \int_0^\pi \sin 2x \cdot \sin\left(\frac{\pi}{2} \cos x\right) dx$$

$$\Rightarrow 2I = 2 \int_0^\pi \sin x \cos x \cdot \sin\left(\frac{\pi}{2} \cos x\right) dx$$

$$\Rightarrow I = \int_0^\pi \sin x \cos x \cdot \sin\left(\frac{\pi}{2} \cos x\right) dx$$

$$\left[\text{put } \frac{\pi}{2} \cos x = t \Rightarrow -\frac{\pi}{2} \sin x dx = dt \Rightarrow \sin x dx = -\frac{2}{\pi} dt \right]$$

$$\therefore I = -\frac{2}{\pi} \int_{\pi/2}^{-\pi/2} \frac{-\pi/2 t}{\pi} \cdot \sin t dt$$

$$= \frac{4}{\pi^2} \int_{-\pi/2}^{\pi/2} t \sin t dt$$

$$\Rightarrow I = \frac{4}{\pi^2} [-t \cos t + \sin t]_{-\pi/2}^{\pi/2}$$

$$= \frac{4}{\pi^2} \times 2 = \frac{8}{\pi^2}$$

86. Let
$$I = \int_0^{\pi/2} f(\sin 2x) \sin x dx \quad \dots(i)$$

Then,
$$I = \int_0^{\pi/2} f\left[\sin 2\left(\frac{\pi}{2} - x\right)\right] \sin\left(\frac{\pi}{2} - x\right) dx$$

$$= \int_0^{\pi/2} f[\sin 2x] \cdot \cos x dx \quad \dots(ii)$$

On adding Eqs. (i) and (ii), we get

$$2I = \int_0^{\pi/2} f(\sin 2x)(\sin x + \cos x) dx$$

$$= 2 \int_0^{\pi/4} f(\sin 2x)(\sin x + \cos x) dx$$

$$= 2\sqrt{2} \int_0^{\pi/4} f(\sin 2x) \sin\left(x + \frac{\pi}{4}\right) dx$$

$$= 2\sqrt{2} \int_0^{\pi/4} f\left(\sin 2\left(\frac{\pi}{4} - x\right)\right) \sin\left(\frac{\pi}{4} - x + \frac{\pi}{4}\right) dx$$

$$= 2\sqrt{2} \int_0^{\pi/4} f(\cos 2x) \cos x dx$$

$$\therefore I = \sqrt{2} \int_0^{\pi/4} f(\cos 2x) \cos x dx$$

Hence,
$$\int_0^{\pi/2} f(\sin 2x) \cdot \sin x dx = \sqrt{2} \int_0^{\pi/4} f(\cos 2x) \cos x dx$$

87. We know that,

$$2 \sin x [\cos x + \cos 3x + \cos 5x + \dots + \cos(2k-1)x]$$

$$= 2 \sin x \cos x + 2 \sin x \cos 3x + 2 \sin x \cos 5x$$

$$+ \dots + 2 \sin x \cos(2k-1)x$$

$$= \sin 2x + (\sin 4x - \sin 2x) + (\sin 6x - \sin 4x)$$

$$+ \dots + \{\sin 2kx - \sin(2k-2)x\}$$

$$= \sin 2kx$$

$$\therefore 2 [\cos x + \cos 3x + \cos 5x + \dots + \cos(2k-1)x]$$

$$= \frac{\sin 2kx}{\sin x} \quad \dots(i)$$

Now,
$$\sin 2kx \cdot \cot x = \frac{\sin 2kx}{\sin x} \cdot \cos x$$

$$= 2 \cos x [\cos x + \cos 3x + \cos 5x + \dots + \cos(2k-1)x]$$

[from Eq. (i)]

$$= [2 \cos^2 x + 2 \cos x \cos 3x + 2 \cos x \cos 5x +$$

$$\dots + 2 \cos x \cos(2k-1)x]$$

$$= (1 + \cos 2x) + (\cos 4x + \cos 2x)$$

$$+ (\cos 6x + \cos 4x) + \dots + \{\cos 2kx + \cos(2k-2)x\}$$

$$= 1 + 2 [\cos 2x + \cos 4x + \cos 6x + \dots + \cos(2k-2)x]$$

$$+ \cos 2kx$$

$$\therefore \int_0^{\pi/2} (\sin 2kx) \cdot \cot x dx$$

$$= \int_0^{\pi/2} 1 \cdot dx + 2 \int_0^{\pi/2} (\cos 2x + \cos 4x \dots \cos(2k-2)x) dx$$

$$+ \int_0^{\pi/2} \cos(2k)x dx$$

$$= \frac{\pi}{2} + 2 \left[\frac{\sin 2x}{2} + \frac{\sin 4x}{4} + \dots + \frac{\sin(2k-2)x}{(2k-2)} \right]_0^{\pi/2}$$

$$+ \left[\frac{\sin(2k)x}{2k} \right]_0^{\pi/2} = \frac{\pi}{2}$$

88. Let
$$I = \int_0^a f(x) \cdot g(x) dx$$

$$I = \int_0^a f(a-x) \cdot g(a-x) dx$$

$$= \int_0^a f(x) \cdot \{2 - g(x)\} dx$$

[∵ $f(a-x) = f(x)$ and $g(x) + g(a-x) = 2$]

$$= 2 \int_0^a f(x) dx - \int_0^a f(x) g(x) dx$$

$$\Rightarrow I = 2 \int_0^a f(x) dx - I \Rightarrow 2I = 2 \int_0^a f(x) dx$$

$$\therefore \int_0^a f(x) g(x) dx = \int_0^a f(x) dx$$

89. Let
$$I = \int_0^{2a} \frac{f(x)}{f(x) + f(2a-x)} dx \quad \dots(i)$$

$$I = \int_0^{2a} \frac{f(2a-x)}{f(2a-x) + f(x)} dx \quad \dots(ii)$$

On adding Eqs. (i) and (ii), we get

$$2I = \int_0^{2a} 1 dx = 2a \Rightarrow I = a$$

90. Let $I = \int_0^1 \log(\sqrt{1-x} + \sqrt{1+x}) dx$

Put $x = \cos 2\theta$

$\Rightarrow dx = -2 \sin 2\theta d\theta$

$\therefore I = -2 \int_{\pi/4}^0 \log[\sqrt{1-\cos 2\theta} + \sqrt{1+\cos 2\theta}] (\sin 2\theta) d\theta$

$= -2 \int_{\pi/4}^0 \log[\sqrt{2}(\sin \theta + \cos \theta)] \sin 2\theta d\theta$

$= -2 \int_{\pi/4}^0 [(\log \sqrt{2}) \sin 2\theta + \log(\sin \theta + \cos \theta) \cdot \sin 2\theta] d\theta$

$= -2 \log \sqrt{2} \left[\frac{-\cos 2\theta}{2} \right]_{\pi/4}^0 - 2 \int_{\pi/4}^0 \log(\sin \theta + \cos \theta) \cdot \sin 2\theta d\theta$

$= \log \sqrt{2} - 2 \left[- \left\{ \log(\sin \theta + \cos \theta) \cdot \frac{\cos 2\theta}{2} \right\}_{\pi/4}^0 - \int_{\pi/4}^0 \left(\frac{\cos \theta - \sin \theta}{\cos \theta + \sin \theta} \times \frac{-\cos 2\theta}{2} \right) d\theta \right]$

$= \log(\sqrt{2}) - 2 \left[0 + \frac{1}{2} \int_{\pi/4}^0 (\cos \theta - \sin \theta)^2 d\theta \right]$

$= \frac{1}{2} \log 2 - \int_{\pi/4}^0 (1 - \sin 2\theta) d\theta$

$= \frac{1}{2} \log 2 - \left[\theta + \frac{\cos 2\theta}{2} \right]_{\pi/4}^0$

$= \frac{1}{2} \log 2 - \left(\frac{1}{2} - \frac{\pi}{4} \right) = \frac{1}{2} \log 2 - \frac{1}{2} + \frac{\pi}{4}$

91. Let $I = \int_0^\pi \frac{x}{1 + \cos \alpha \sin x} dx$... (i)

$\Rightarrow I = \int_0^\pi \frac{(\pi - x)}{1 + \cos \alpha \sin(\pi - x)} dx$

$\Rightarrow I = \int_0^\pi \frac{(\pi - x)}{1 + \cos \alpha \sin x} dx$... (ii)

On adding Eqs. (i) and (ii), we get

$2I = \pi \int_0^\pi \frac{dx}{1 + \cos \alpha \sin x}$

$\Rightarrow 2I = \pi \int_0^\pi \frac{\sec^2 \frac{x}{2} dx}{(1 + \tan^2 \frac{x}{2}) + 2 \cos \alpha \tan \frac{x}{2}}$

Put $\tan \frac{x}{2} = t \Rightarrow \sec^2 \frac{x}{2} dx = 2 dt$

$\therefore 2I = \pi \int_0^\infty \frac{2 dt}{1 + t^2 + 2t \cos \alpha}$

$\Rightarrow 2I = 2\pi \int_0^\infty \frac{dt}{(t + \cos \alpha)^2 + \sin^2 \alpha}$

$I = \frac{\pi}{\sin \alpha} \left[\tan^{-1} \left(\frac{t + \cos \alpha}{\sin \alpha} \right) \right]_0^\infty$

$= \frac{\pi}{\sin \alpha} [\tan^{-1}(\infty) - \tan^{-1}(\cot \alpha)]$

$= \frac{\pi}{\sin \alpha} \left(\frac{\pi}{2} - \left(\frac{\pi}{2} - \alpha \right) \right) = \frac{\alpha \pi}{\sin \alpha}$

$\therefore I = \frac{\alpha \pi}{\sin \alpha}$

92. Let $I = \int_0^{\pi/2} \frac{x \sin x \cdot \cos x}{\cos^4 x + \sin^4 x} dx$

$\Rightarrow I = \int_0^{\pi/2} \frac{\left(\frac{\pi}{2} - x \right) \sin \left(\frac{\pi}{2} - x \right) \cdot \cos \left(\frac{\pi}{2} - x \right)}{\sin^4 \left(\frac{\pi}{2} - x \right) + \cos^4 \left(\frac{\pi}{2} - x \right)} dx$

$\Rightarrow I = \int_0^{\pi/2} \frac{\left(\frac{\pi}{2} - x \right) \cdot \sin x \cos x}{\cos^4 x + \sin^4 x} dx$

$\Rightarrow I = \frac{\pi}{2} \int_0^{\pi/2} \frac{\sin x \cos x}{\sin^4 x + \cos^4 x} dx - \int_0^{\pi/2} \frac{x \sin x \cdot \cos x}{\sin^4 x + \cos^4 x} dx$

$= \frac{\pi}{2} \int_0^{\pi/2} \frac{\sin x \cdot \cos x}{\sin^4 x + \cos^4 x} dx - I$

$\Rightarrow 2I = \frac{\pi}{2} \int_0^{\pi/2} \frac{\tan x \cdot \sec^2 x}{\tan^4 x + 1} dx$

$\Rightarrow 2I = \frac{\pi}{2} \cdot \frac{1}{2} \int_0^{\pi/2} \frac{1}{1 + (\tan^2 x)^2} d(\tan^2 x)$

$\Rightarrow 2I = \frac{\pi}{4} \cdot [\tan^{-1} t]_0^\infty = \frac{\pi}{4} (\tan^{-1} \infty - \tan^{-1} 0)$

[where, $t = \tan^2 x$]

$\Rightarrow I = \frac{\pi^2}{16}$

93. Let $I = \int_0^{1/2} \frac{x \sin^{-1} x}{\sqrt{1-x^2}} dx$ Put $\sin^{-1} x = \theta \Rightarrow x = \sin \theta$

$\Rightarrow dx = \cos \theta d\theta$

$\therefore I = \int_0^{\pi/6} \frac{\theta \sin \theta}{\sqrt{1-\sin^2 \theta}} \cdot \cos \theta d\theta = \int_0^{\pi/6} \theta \sin \theta d\theta$

$= [-\theta \cos \theta]_0^{\pi/6} + \int_0^{\pi/6} \cos \theta d\theta$

$= \left(-\frac{\pi}{6} \cos \frac{\pi}{6} + 0 \right) + \left(\sin \frac{\pi}{6} - \sin 0 \right) = -\frac{\sqrt{3} \pi}{12} + \frac{1}{2}$

94. Let $I = \int_0^{\pi/4} \frac{(\sin x + \cos x)}{9 + 16 \sin 2x} dx$

$I = \int_0^{\pi/4} \frac{\sin x + \cos x}{25 - 16(\sin x - \cos x)^2} dx$

Put $4(\sin x - \cos x) = t \Rightarrow 4(\cos x + \sin x) dx = dt$

$\therefore I = \frac{1}{4} \int_{-4}^0 \frac{dt}{25 - t^2} = \frac{1}{4} \cdot \frac{1}{2(5)} \log \left[\frac{5+t}{5-t} \right]_{-4}^0$

$I = \frac{1}{40} \left[\log \left| \frac{5+0}{5-0} \right| - \log \left| \frac{5-4}{5+4} \right| \right]$

$= \frac{1}{40} \left(\log 1 - \log \frac{1}{9} \right) = \frac{1}{40} \log 9 = \frac{1}{20} (\log 3)$

322 Definite Integration

95. (i) Let $I = \int_0^\pi x f(\sin x) dx$... (i)

$\Rightarrow I = \int_0^\pi (\pi - x) f(\sin x) dx$... (ii)

On adding Eqs. (i) and (ii), we get

$$2I = \int_0^\pi \pi f(\sin x) dx$$

$$\therefore \int_0^\pi x f(\sin x) dx = \frac{\pi}{2} \int_0^\pi f(\sin x) dx$$

(ii) Let $I = \int_{-1}^{3/2} |x \sin \pi x| dx$

Since, $|x \sin \pi x| = \begin{cases} x \sin \pi x, & -1 < x \leq 1 \\ -x \sin \pi x, & 1 < x < \frac{3}{2} \end{cases}$

$$\begin{aligned} \therefore I &= \int_{-1}^1 x \sin \pi x dx + \int_1^{3/2} -x \sin \pi x dx \\ &= 2 \left[-\frac{x \cos \pi x}{\pi} \right]_0^1 - 2 \int_0^1 1 \cdot \left(\frac{-\cos \pi x}{\pi} \right) dx \\ &\quad - \left[\frac{-x \cos \pi x}{\pi} \right]_1^{3/2} - \int_1^{3/2} \left(\frac{-\cos \pi x}{\pi} \right) dx \end{aligned}$$

$$\begin{aligned} &= 2 \left(\frac{1}{\pi} \right) + \frac{2}{\pi} \left[\frac{\sin \pi x}{\pi} \right]_0^1 - \left(-\frac{1}{\pi} \right) - \frac{1}{\pi} \left[\frac{\sin \pi x}{\pi} \right]_1^{3/2} \\ &= \frac{2}{\pi} + \frac{2}{\pi^2} (0 - 0) + \frac{1}{\pi} + \frac{1}{\pi^2} (+1 - 0) \\ &= \frac{3}{\pi} + \frac{1}{\pi^2} = \left(\frac{3\pi + 1}{\pi^2} \right) \end{aligned}$$

96. Let $I = \int_0^1 (tx + 1 - x)^n dx = \int_0^1 \{(t-1)x + 1\}^n dx$

$$= \left[\frac{((t-1)x + 1)^{n+1}}{(n+1)(t-1)} \right]_0^1 = \frac{1}{n+1} \left(\frac{t^{n+1} - 1}{t-1} \right)$$

$$= \frac{1}{n+1} (1 + t + t^2 + \dots + t^n) \quad \dots (i)$$

Again, $I = \int_0^1 (tx + 1 - x)^n dx = \int_0^1 [(1-x) + tx]^n dx$

$$= \int_0^1 [{}^n C_0 (1-x)^n + {}^n C_1 (1-x)^{n-1} (tx) + \dots + {}^n C_n (tx)^n] dx$$

$$= \int_0^1 \left[\sum_{r=0}^n {}^n C_r (1-x)^{n-r} (tx)^r \right] dx$$

$$= \sum_{r=0}^n {}^n C_r \left[\int_0^1 (1-x)^{n-r} \cdot x^r dx \right] t^r \quad \dots (ii)$$

From Eqs. (i) and (ii), we get

$$\sum_{r=0}^n {}^n C_r \left[\int_0^1 (1-x)^{n-r} \cdot x^r dx \right] t^r = \frac{1}{n+1} (1 + t + \dots + t^n)$$

On equating coefficient of t^k on both sides, we get

$${}^n C_k \left[\int_0^1 (1-x)^{n-k} \cdot x^k dx \right] = \frac{1}{n+1}$$

$$\Rightarrow \int_0^1 (1-x)^{n-k} x^k dx = \frac{1}{(n+1) {}^n C_k}$$

Topic 2 Periodicity of Integral Functions

1. Let $I = \int_{-\frac{\pi}{2}}^{\frac{\pi}{2}} \frac{dx}{[x] + [\sin x] + 4}$

$$= \int_{-\frac{\pi}{2}}^{-1} \frac{dx}{[x] + [\sin x] + 4} + \int_{-1}^0 \frac{dx}{[x] + [\sin x] + 4}$$

$$+ \int_0^1 \frac{dx}{[x] + [\sin x] + 4} + \int_1^{\frac{\pi}{2}} \frac{dx}{[x] + [\sin x] + 4}$$

$$\therefore [x] = \begin{cases} -2, & -\pi/2 < x < -1 \\ -1, & -1 \leq x < 0 \\ 0, & 0 \leq x < 1 \\ 1, & 1 \leq x < \pi/2 \end{cases}$$

$$\text{and } [\sin x] = \begin{cases} -1, & -\pi/2 < x < -1 \\ -1, & -1 \leq x < 0 \\ 0, & 0 < x < 1 \\ 0, & 1 < x < \pi/2 \end{cases}$$

[∵ For $x < 0, -1 \leq \sin x < 0$ and for $x > 0, 0 < \sin x \leq 1$]

So, $I = \int_{-\frac{\pi}{2}}^{-1} \frac{dx}{-2-1+4} + \int_{-1}^0 \frac{dx}{-1-1+4} + \int_0^1 \frac{dx}{0+0+4}$

$$+ \int_1^{\frac{\pi}{2}} \frac{dx}{1+0+4}$$

$$= \int_{-\frac{\pi}{2}}^{-1} \frac{dx}{1} + \int_{-1}^0 \frac{dx}{2} + \int_0^1 \frac{dx}{4} + \int_1^{\frac{\pi}{2}} \frac{dx}{5}$$

$$= \left(-1 + \frac{\pi}{2} \right) + \frac{1}{2} (0+1) + \frac{1}{4} (1-0) + \frac{1}{5} \left(\frac{\pi}{2} - 1 \right)$$

$$= \left(-1 + \frac{1}{2} + \frac{1}{4} - \frac{1}{5} \right) + \left(\frac{\pi}{2} + \frac{\pi}{10} \right)$$

$$= \frac{-20+10+5-4}{20} + \frac{5\pi+ \pi}{10}$$

$$= -\frac{9}{20} + \frac{3\pi}{5} = \frac{3}{20} (4\pi - 3)$$

2. $\int_3^{3+3T} f(2x) dx$ Put $2x = y \Rightarrow dx = \frac{1}{2} dy$

$$\therefore \frac{1}{2} \int_6^{6+6T} f(y) dy = \frac{6I}{2} = 3I$$

3. Given, $g(x) = \int_0^x f(t) dt$

$$\Rightarrow g(2) = \int_0^2 f(t) dt = \int_0^1 f(t) dt + \int_1^2 f(t) dt$$

Now, $\frac{1}{2} \leq f(t) \leq 1$ for $t \in [0, 1]$

We get $\int_0^1 \frac{1}{2} dt \leq \int_0^1 f(t) dt \leq \int_0^1 1 dt$

$$\Rightarrow \frac{1}{2} \leq \int_0^1 f(t) dt \leq 1 \quad \dots (i)$$

Again, $0 \leq f(t) \leq \frac{1}{2}$ for $t \in [1, 2]$... (ii)

$$\Rightarrow \int_1^2 0 dt \leq \int_1^2 f(t) dt \leq \int_1^2 \frac{1}{2} dt$$

$$\Rightarrow 0 \leq \int_1^2 f(t) dt \leq \frac{1}{2}$$

From Eqs. (i) and (ii), we get

$$\frac{1}{2} \leq \int_0^1 f(t) dt + \int_1^2 f(t) dt \leq \frac{3}{2}$$

$$\Rightarrow \frac{1}{2} \leq g(2) \leq \frac{3}{2} \Rightarrow 0 \leq g(2) < 2$$

$$4. \int_0^{n\pi+v} |\sin x| dx = \int_0^\pi |\sin x| dx + \int_\pi^{2\pi} |\sin x| dx + \dots$$

$$+ \int_{(n-1)\pi}^{n\pi} |\sin x| dx + \int_{n\pi}^{n\pi+v} |\sin x| dx$$

$$= \sum_{r=1}^n \int_{(r-1)\pi}^{r\pi} |\sin x| dx + \int_{n\pi}^{n\pi+v} |\sin x| dx$$

Now to solve, $\int_{(r-1)\pi}^{r\pi} |\sin x| dx$, we have

$$x = (r-1)\pi + t$$

$$\Rightarrow \sin x = \sin [(r-1)\pi + t] = (-1)^{r-1} \sin t$$

and when $x = (r-1)\pi$, $t=0$ and when

$$x = r\pi, t = \pi$$

$$\therefore \int_{(r-1)\pi}^{r\pi} |\sin x| dx = \int_0^\pi |(-1)^{r-1} \sin t| dt$$

$$= \int_0^\pi |\sin t| dt = \int_0^\pi \sin t dt$$

$$= [-\cos t]_0^\pi = -\cos \pi + \cos 0 = 2$$

Again, $\int_{n\pi}^{n\pi+v} |\sin x| dx$, putting $x = n\pi + t$

$$\text{Then, } \int_{n\pi}^{n\pi+v} |\sin x| dx = \int_0^v |(-1)^n \sin t| dt = \int_0^v \sin t dt$$

$$= [-\cos t]_0^v = -\cos v + \cos 0 = 1 - \cos v$$

$$\therefore \int_0^{n\pi+v} |\sin x| dx = \sum_{r=1}^n \int_{(r-1)\pi}^{r\pi} |\sin x| dx + \int_{n\pi}^{n\pi+v} |\sin x| dx$$

$$= \sum_{r=1}^n 2 + \int_{n\pi}^{n\pi+v} |\sin x| dx = 2n + 1 - \cos v$$

5. Let $\phi(a) = \int_a^{a+t} f(x) dx$

On differentiating w.r.t. a , we get

$$\phi'(a) = f(a+t) \cdot 1 - f(a) \cdot 1 = 0 \text{ [given, } f(x+t) = f(x)]$$

$$\therefore \phi(a) \text{ is constant.}$$

$\Rightarrow \int_a^{a+t} f(x) dx$ is independent of a .

6. Given, $f(x) = \begin{cases} x - [x], & \text{if } [x] \text{ is odd.} \\ 1 + [x] - x, & \text{if } [x] \text{ is even.} \end{cases}$

$f(x)$ and $\cos \pi x$ both are periodic with period 2 and both are even.

$$\therefore \int_{-10}^{10} f(x) \cos \pi x dx = 2 \int_0^{10} f(x) \cos \pi x dx$$

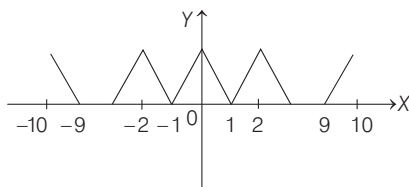

$$= 10 \int_0^2 f(x) \cos \pi x dx$$

Now, $\int_0^1 f(x) \cos \pi x dx$

$$= \int_0^1 (1-x) \cos \pi x dx = - \int_0^1 u \cos \pi u du$$

and $\int_1^2 f(x) \cos \pi x dx = \int_1^2 (x-1) \cos \pi x dx$

$$= - \int_0^1 u \cos \pi u du$$

$$\therefore \int_{-10}^{10} f(x) \cos \pi x dx = -20 \int_0^1 u \cos \pi u du = \frac{40}{\pi^2}$$

$$\Rightarrow \frac{\pi^2}{10} \int_{-10}^{10} f(x) \cos \pi x dx = 4$$

Topic 3 Estimation, Gamma Function and Derivative of Definite Integration

1. Given, $\int_0^x f(t) dt = x^2 + \int_x^1 t^2 f(t) dt$

On differentiating both sides, w.r.t. 'x', we get

$$f(x) = 2x + 0 - x^2 f(x)$$

$$\left[\therefore \frac{d}{dx} \left[\int_{\phi(x)}^{\psi(x)} f(t) dt \right] = f(\psi(x)) \frac{d}{dx} \psi(x) - f(\phi(x)) \frac{d}{dx} \phi(x) \right]$$

$$\Rightarrow (1+x^2) f(x) = 2x \Rightarrow f(x) = \frac{2x}{1+x^2}$$

On differentiating w.r.t. 'x' we get

$$f'(x) = \frac{(1+x^2)(2) - (2x)(0+2x)}{(1+x^2)^2} = \frac{2+2x^2-4x^2}{(1+x^2)^2} = \frac{2-2x^2}{(1+x^2)^2}$$

$$\therefore f'\left(\frac{1}{2}\right) = \frac{2-2\left(\frac{1}{2}\right)^2}{\left(1+\left(\frac{1}{2}\right)^2\right)^2} = \frac{2-2\left(\frac{1}{4}\right)}{\left(1+\frac{1}{4}\right)^2} = \frac{2-\frac{1}{2}}{\left(\frac{5}{4}\right)^2} = \frac{\frac{3}{2}}{\frac{25}{16}} = \frac{24}{25}$$

2. **PLAN** Newton-Leibnitz's formula

$$\frac{d}{dx} \left[\int_{\phi(x)}^{\psi(x)} f(t) dt \right] = f\{\psi(x)\} \left\{ \frac{d}{dx} \psi(x) \right\} - f\{\phi(x)\} \left\{ \frac{d}{dx} \phi(x) \right\}$$

Given, $F(x) = \int_0^{x^2} f(\sqrt{t}) dt$

$$\therefore F'(x) = 2x f(x)$$

Also, $F'(x) = f'(x) \Rightarrow 2x f(x) = f'(x)$

$$\Rightarrow \frac{f'(x)}{f(x)} = 2x \Rightarrow \int \frac{f'(x)}{f(x)} dx = \int 2x dx$$

$$\Rightarrow \ln f(x) = x^2 + c$$

$$\Rightarrow f(x) = e^{x^2+c}$$

$$\Rightarrow f(x) = K e^{x^2} \quad [K = e^c]$$

324 Definite Integration

Now, $f(0) = 1$
 $\therefore 1 = K$
Hence, $f(x) = e^{x^2}$
 $F(2) = \int_0^4 e^t dt = [e^t]_0^4 = e^4 - 1$

3. Given, $y = \int_0^x |t| dt$
 $\therefore \frac{dy}{dx} = |x| \cdot 1 - 0 = |x|$ [by Leibnitz's rule]
 \therefore Tangent to the curve $y = \int_0^x |t| dt, x \in R$ are parallel to the line $y = 2x$
 \therefore Slope of both are equal $\Rightarrow x = \pm 2$

Points, $y = \int_0^{\pm 2} |t| dt = \pm 2$

Equation of tangent is
 $y - 2 = 2(x - 2)$ and $y + 2 = 2(x + 2)$
For x intercept put $y = 0$, we get
 $0 - 2 = 2(x - 2)$ and $0 + 2 = 2(x + 2) \Rightarrow x = \pm 1$

4. Given $\int_0^x \sqrt{1 - \{f'(t)\}^2} dt = \int_0^x f(t) dt, 0 \leq x \leq 1$
Differentiating both sides w.r.t. x by using Leibnitz's rule, we get

$$\sqrt{1 - \{f'(x)\}^2} = f(x) \Rightarrow f'(x) = \pm \sqrt{1 - \{f(x)\}^2}$$

$$\Rightarrow \int \frac{f'(x)}{\sqrt{1 - \{f(x)\}^2}} dx = \pm \int dx$$

$$\Rightarrow \sin^{-1} \{f(x)\} = \pm x + c$$

Put $x = 0 \Rightarrow \sin^{-1} \{f(0)\} = c$
 $\Rightarrow c = \sin^{-1}(0) = 0$ [$\because f(0) = 0$]
 $\therefore f(x) = \pm \sin x$
but $f(x) \geq 0, \forall x \in [0, 1]$
 $\therefore f(x) = \sin x$

As we know that,
 $\sin x < x, \forall x > 0$
 $\therefore \sin\left(\frac{1}{2}\right) < \frac{1}{2}$ and $\sin\left(\frac{1}{3}\right) < \frac{1}{3}$
 $\Rightarrow f\left(\frac{1}{2}\right) < \frac{1}{2}$ and $f\left(\frac{1}{3}\right) < \frac{1}{3}$

5. Since $\int_{\sin x}^1 t^2 f(t) dt = 1 - \sin x$, thus to find $f(x)$.
On differentiating both sides using Newton Leibnitz formula
i.e. $\frac{d}{dx} \int_{\sin x}^1 t^2 f(t) dt = \frac{d}{dx} (1 - \sin x)$
 $\Rightarrow \{1^2 f(1)\} \cdot (0) - (\sin^2 x) \cdot f(\sin x) \cdot \cos x = -\cos x$
 $\Rightarrow f(\sin x) = \frac{1}{\sin^2 x}$

For $f\left(\frac{1}{\sqrt{3}}\right)$ is obtained when $\sin x = 1/\sqrt{3}$
i.e. $f\left(\frac{1}{\sqrt{3}}\right) = (\sqrt{3})^2 = 3$

6. Here, $\int_0^{t^2} x f(x) dx = \frac{2}{5} t^5$
Using Newton Leibnitz's formula, differentiating both sides, we get

$$t^2 \{f(t^2)\} \left\{ \frac{d}{dt} (t^2) \right\} - 0 \cdot f(0) \left\{ \frac{d}{dt} (0) \right\} = 2t^4$$

$$\Rightarrow t^2 f(t^2) 2t = 2t^4 \Rightarrow f(t^2) = t$$

$$\therefore f\left(\frac{4}{25}\right) = -\frac{2}{5} \quad \left[\text{putting } t = \frac{2}{5} \right]$$

$$\Rightarrow f\left(\frac{4}{25}\right) = \frac{2}{5}$$

7. Given, $f(x) = \int_{x^2}^{x^2+1} e^{-t^2} dt$
On differentiating both sides using Newton's Leibnitz's formula, we get

$$f'(x) = e^{-(x^2+1)^2} \left\{ \frac{d}{dx} (x^2+1) \right\} - e^{-(x^2)^2} \left\{ \frac{d}{dx} (x^2) \right\}$$

$$= e^{-(x^2+1)^2} \cdot 2x - e^{-(x^2)^2} \cdot 2x$$

$$= 2xe^{-(x^4+2x^2+1)} (1 - e^{2x^2+1})$$

[where, $e^{2x^2+1} > 1, \forall x$ and $e^{-(x^4+2x^2+1)} > 0, \forall x$]

$$\therefore f'(x) > 0$$

which shows $2x < 0$ or $x < 0 \Rightarrow x \in (-\infty, 0)$

8. Here, $I(m, n) = \int_0^1 t^m (1+t)^n dt$ reduce into $I(m+1, n-1)$
[we apply integration by parts taking $(1+t)^n$ as first and t^m as second function]

$$\therefore I(m, n) = \left[(1+t)^n \cdot \frac{t^{m+1}}{m+1} \right]_0^1 - \int_0^1 n(1+t)^{n-1} \cdot \frac{t^{m+1}}{m+1} dt$$

$$= \frac{2^n}{m+1} - \frac{n}{m+1} \int_0^1 (1+t)^{n-1} \cdot t^{m+1} dt$$

$$\therefore I(m, n) = \frac{2^n}{m+1} - \frac{n}{m+1} \cdot I(m+1, n-1)$$

9. Given, $f(x) = \int_1^x \sqrt{2-t^2} dt \Rightarrow f'(x) = \sqrt{2-x^2}$

Also, $x^2 - f'(x) = 0$
 $\therefore x^2 = \sqrt{2-x^2} \Rightarrow x^4 = 2 - x^2$
 $\Rightarrow x^4 + x^2 - 2 = 0 \Rightarrow x = \pm 1$

10. Given, $F(x) = \int_0^x f(t) dt$
By Leibnitz's rule,
 $F'(x) = f(x)$... (i)
But $F(x^2) = x^2(1+x) = x^2 + x^3$ [given]
 $\Rightarrow F(x) = x + x^{3/2} \Rightarrow F'(x) = 1 + \frac{3}{2}x^{1/2}$
 $\Rightarrow f(x) = F'(x) = 1 + \frac{3}{2}x^{1/2}$ [from Eq. (i)]
 $\Rightarrow f(4) = 1 + \frac{3}{2}(4)^{1/2} \Rightarrow f(4) = 1 + \frac{3}{2} \times 2 = 4$

11. Given, $\int_0^x f(t)dt = x + \int_x^1 t f(t) dt$

On differentiating both sides w.r.t. x , we get

$$f(x) \cdot 1 = 1 - x f(x) \cdot 1 \Rightarrow (1+x)f(x) = 1$$

$$\Rightarrow f(x) = \frac{1}{1+x} \Rightarrow f(1) = \frac{1}{1+1} = \frac{1}{2}$$

12. $\lim_{x \rightarrow 1} \int_4^{f(x)} \frac{2t}{x-1} dt = \lim_{x \rightarrow 1} \frac{\int_4^{f(x)} 2t dt}{x-1}$
 [using L' Hospital's rule]
 $= \lim_{x \rightarrow 1} \frac{2f(x) \cdot f'(x)}{1} = 2f(1) \cdot f'(1)$
 $= 8f'(1)$ [∵ $f(1) = 4$]

13. If $f(x)$ is a continuous function defined on $[a, b]$, then

$$m(b-a) \leq \int_a^b f(x) dx \leq M(b-a)$$

where, M and m are maximum and minimum values respectively of $f(x)$ in $[a, b]$.

Here, $f(x) = 1 + e^{-x^2}$ is continuous in $[0, 1]$.

Now, $0 < x < 1 \Rightarrow x^2 < x \Rightarrow e^{x^2} < e^x \Rightarrow e^{-x^2} > e^{-x}$

Again, $0 < x < 1 \Rightarrow x^2 > 0 \Rightarrow e^{x^2} > e^0 \Rightarrow e^{-x^2} < 1$

$$\therefore e^{-x} < e^{-x^2} < 1, \forall x \in [0, 1]$$

$$\Rightarrow 1 + e^{-x} < 1 + e^{-x^2} < 2, \forall x \in [0, 1]$$

$$\Rightarrow \int_0^1 (1 + e^{-x}) dx < \int_0^1 (1 + e^{-x^2}) dx < \int_0^1 2 dx$$

$$\Rightarrow 2 - \frac{1}{e} < \int_0^1 (1 + e^{-x^2}) dx < 2$$

14. ∵ $\cos x = 1 - \frac{x^2}{2!} + \frac{x^4}{4!} - \frac{x^6}{6!} + \dots$

and $\sin x = x - \frac{x^3}{3!} + \frac{x^5}{5!} - \frac{x^7}{7!} + \dots$

$$\therefore \int_0^1 x \cos x dx \geq \int_0^1 \left(x - \frac{x^3}{2!}\right) dx = \left[\frac{x^2}{2} - \frac{x^4}{8}\right]_0^1 = \frac{1}{2} - \frac{1}{8} = \frac{3}{8}$$

$$\Rightarrow \int_0^1 x \cos x dx \geq \frac{3}{8}$$

and, $\int_0^1 x \sin x dx \geq \int_0^1 \left(x^2 - \frac{x^4}{6}\right) dx$

$$= \left[\frac{x^3}{3} - \frac{x^5}{30}\right]_0^1 = \frac{1}{3} - \frac{1}{30} = \frac{9}{30} = \frac{3}{10}$$

$$\Rightarrow \int_0^1 x \sin x dx \geq \frac{3}{10}$$

and, $\int_0^1 x^2 \cos x dx \geq \int_0^1 \left(x^3 - \frac{x^5}{2}\right) dx$

$$= \left[\frac{x^4}{4} - \frac{x^6}{12}\right]_0^1 = \frac{1}{4} - \frac{1}{12} = \frac{2}{12} = \frac{1}{6}$$

$$\therefore \int_0^1 x^2 \cos x dx \geq \frac{1}{6}$$

and, $\int_0^1 x^2 \sin x dx \geq \int_0^1 \left(x^3 - \frac{x^5}{6}\right) dx = \left[\frac{x^4}{4} - \frac{x^6}{36}\right]_0^1$

$$= \frac{1}{4} - \frac{1}{36} = \frac{8}{36} = \frac{2}{9}$$

$$\therefore \int_0^1 x^2 \sin x dx \geq \frac{2}{9}$$

15. $g(x) = \int_{\sin x}^{\sin 2x} \sin^{-1}(t) dt$
 $g'(x) = 2 \cos 2x \sin^{-1}(\sin 2x) - \cos x \sin^{-1}(\sin x)$
 $g'\left(\frac{\pi}{2}\right) = -2 \sin^{-1}(0) = 0 \Rightarrow g'\left(-\frac{\pi}{2}\right) = -2 \sin^{-1}(0) = 0$

No option is matching.

16. Here, $f(x) + 2x = (1-x)^2 \cdot \sin^2 x + x^2 + 2x$... (i)

where, $P: f(x) + 2x = 2(1+x)^2$... (ii)

$$\therefore 2(1+x^2) = (1-x)^2 \sin^2 x + x^2 + 2x$$

$$\Rightarrow (1-x)^2 \sin^2 x = x^2 - 2x + 2$$

$$\Rightarrow (1-x)^2 \sin^2 x = (1-x)^2 + 1 \Rightarrow (1-x)^2 \cos^2 x = -1$$

which is never possible.

∴ P is false.

Again, let $Q: h(x) = 2f(x) + 1 - 2x(1+x)$

where, $h(0) = 2f(0) + 1 - 0 = 1$

$$h(1) = 2f(1) + 1 - 4 = -3, \text{ as } h(0)h(1) < 0$$

$\Rightarrow h(x)$ must have a solution.

∴ Q is true.

17. Here, $f(x) = (1-x)^2 \cdot \sin^2 x + x^2 \geq 0, \forall x$.

and $g(x) = \int_1^x \left(\frac{2(t-1)}{t+1} - \log t\right) f(t) dt$

$$\Rightarrow g'(x) = \left[\frac{2(x-1)}{(x+1)} - \log x\right] \cdot f(x) \quad \dots (i)$$

For $g'(x)$ to be increasing or decreasing,

let $\phi(x) = \frac{2(x-1)}{(x+1)} - \log x$

$$\phi'(x) = \frac{4}{(x+1)^2} - \frac{1}{x} = \frac{-(x-1)^2}{x(x+1)^2}$$

$$\phi'(x) < 0, \text{ for } x > 1 \Rightarrow \phi(x) < \phi(1)$$

$$\Rightarrow \phi(x) < 0 \quad \dots (ii)$$

From Eqs. (i) and (ii), we get

$$g'(x) < 0 \text{ for } x \in (1, \infty)$$

∴ $g(x)$ is decreasing for $x \in (1, \infty)$.

18. Given, $f(x) = \begin{vmatrix} \sec x & \cos x & \operatorname{cosec} x \cdot \cot x + \sec^2 x \\ \cos^2 x & \cos^2 x & \operatorname{cosec}^2 x \\ 1 & \cos^2 x & \cos^2 x \end{vmatrix}$

Applying $R_3 \rightarrow \frac{1}{\cos x} R_3$,

$$f(x) = \cos x \begin{vmatrix} \sec x & \cos x & \operatorname{cosec} x \cdot \cot x + \sec^2 x \\ \cos^2 x & \cos^2 x & \operatorname{cosec}^2 x \\ \sec x & \cos x & \cos x \end{vmatrix}$$

326 Definite Integration

Applying $R_1 \rightarrow R_1 - R_3 \Rightarrow f(x)$

$$= \cos x \begin{vmatrix} 0 & 0 & \operatorname{cosec} x \cdot \cot x + \sec^2 x - \cos x \\ \cos^2 x & \cos^2 x & \operatorname{cosec}^2 x \\ \sec x & \cos x & \cos x \end{vmatrix}$$

$$= (\operatorname{cosec} x \cdot \cot x + \sec^2 x - \cos x) \cdot (\cos^3 x - \cos x) \cdot \cos x$$

$$= - \left[\frac{\sin^2 x + \cos^3 x - \cos^3 x \cdot \sin^2 x}{\sin^2 x \cdot \cos^2 x} \right] \cdot \cos^2 x \cdot \sin^2 x$$

$$= -\sin^2 x - \cos^3 x (1 - \sin^2 x) = -\sin^2 x - \cos^5 x$$

$$\therefore \int_0^{\pi/2} f(x) dx = - \int_0^{\pi/2} (\sin^2 x + \cos^5 x) dx$$

$$\left[\because \int_0^{\pi/2} \sin^m x \cdot \cos^n x dx = \frac{\sqrt{\frac{m+1}{2}} \sqrt{\frac{n+2}{2}}}{2 \sqrt{\frac{m+n+2}{2}}} \right]$$

$$\int_0^{\pi/2} f(x) dx = - \left\{ \frac{\sqrt{\frac{3}{2}} \cdot \sqrt{\frac{1}{2}}}{2 \sqrt{2}} + \frac{\sqrt{\frac{6}{2}} \cdot \sqrt{\frac{1}{2}}}{2 \sqrt{\frac{7}{2}}} \right\}$$

$$= - \left\{ \frac{1/2 \cdot \pi}{2} + \frac{2\sqrt{\pi}}{2 \cdot \frac{5}{2} \cdot \frac{3}{2} \cdot \frac{1}{2} \cdot \sqrt{\pi}} \right\} = - \left\{ \frac{\pi}{4} + \frac{8}{15} \right\} = - \left(\frac{15\pi + 32}{60} \right)$$

19. $f(x) = \int_1^x \frac{\ln t}{1+t} dt$ for $x > 0$ [given]

Now, $f(1/x) = \int_1^{1/x} \frac{\ln t}{1+t} dt$

Put $t = 1/u \Rightarrow dt = (-1/u^2) du$

$$\therefore f(1/x) = \int_1^x \frac{\ln(1/u)}{1+1/u} \cdot \frac{(-1)}{u^2} du$$

$$= \int_1^x \frac{\ln u}{u(u+1)} du = \int_1^x \frac{\ln t}{t(1+t)} dt$$

Now, $f(x) + f\left(\frac{1}{x}\right) = \int_1^x \frac{\ln t}{(1+t)} dt + \int_1^x \frac{\ln t}{t(1+t)} dt$

$$= \int_1^x \frac{(1+t) \ln t}{t(1+t)} dt = \int_1^x \frac{\ln t}{t} dt = \frac{1}{2} [(\ln t)^2]_1^x = \frac{1}{2} (\ln x)^2$$

Put $x = e$,

$$f(e) + f\left(\frac{1}{e}\right) = \frac{1}{2} (\ln e)^2 = \frac{1}{2} \quad \text{Hence proved.}$$

20. Let $t = b - a$ and $a + b = 4$ [given]

$$\Rightarrow t = 4 - a - a$$

$$\Rightarrow t = 4 - 2a$$

$$\Rightarrow a = 2 - \frac{t}{2}$$

and $t = b - (4 - b)$

$$\Rightarrow t = 2b - 4$$

$$\Rightarrow \frac{t}{2} = b - 2$$

$$\Rightarrow b = 2 + \frac{t}{2}$$

Again, $a < 2$ [given]

$$\Rightarrow 2 - \frac{\pi}{2} < 2 \Rightarrow \frac{\pi}{2} > 0 \Rightarrow t > 0$$

Now, $\int_0^a g(x) dx + \int_0^b g(x) dx$

$$= \int_0^{2-t/2} g(x) dx + \int_0^{2+t/2} g(x) dx$$

Let $F(x) = \int_0^x g(x) dx + \int_0^{2+t/2} g(x) dx$

For $t > 0$, $F'(t) = -\frac{1}{2} g\left(2 - \frac{t}{2}\right) + \frac{1}{2} g\left(2 + \frac{t}{2}\right)$ [using Leibnitz's rule]

$$= \frac{1}{2} g\left(2 + \frac{t}{2}\right) - \frac{1}{2} g\left(2 - \frac{t}{2}\right)$$

Again, $\frac{dg}{dx} > 0, \forall x \in R$ [given]

Now, $2 - t/2 < 2 + t/2 \therefore t > 0$

We get $g(2 + t/2) - g(2 - t/2) > 0, \forall t > 0$

So, $F'(t) > 0, \forall t > 0$

Hence, $F(t)$ increases with t , therefore $F(t)$ increases as $(b - a)$ increases.

21. Let $I_n = \int_0^1 e^x (x-1)^n dx$

Put $x - 1 = t \Rightarrow dx = dt$

$$\therefore I_n = \int_{-1}^0 e^{t+1} \cdot t^n dt = e \int_{-1}^0 t^n e^t dt$$

$$= e \left([t^n e^t]_{-1}^0 - n \int_{-1}^0 t^{n-1} e^t dt \right)$$

$$= e \left(0 - (-1)^n e^{-1} - n \int_{-1}^0 t^{n-1} e^t dt \right)$$

$$= (-1)^{n+1} - ne \int_{-1}^0 t^{n-1} e^t dt$$

$$\Rightarrow I_n = (-1)^{n+1} - nI_{n-1} \quad \dots(i)$$

For $n = 1$, $I_1 = \int_0^1 e^x (x-1) dx = [e^x (x-1)]_0^1 - \int_0^1 e^x dx$

$$= e^1 (1-1) - e^0 (0-1) - [e^x]_0^1 = 1 - (e-1) = 2 - e$$

Therefore, from Eq. (i), we get

$$I_2 = (-1)^{2+1} - 2I_1 = -1 - 2(2-e) = 2e - 5$$

and $I_3 = (-1)^{3+1} - 3I_2 = 1 - 3(2e-5) = 16 - 6e$

Hence, $n = 3$ is the answer.

22. Since, f is continuous function and $\int_0^x f(t) dt \rightarrow \infty$, as $|x| \rightarrow \infty$. To show that every line $y = mx$ intersects the curve $y^2 + \int_0^x f(t) dt = 2$

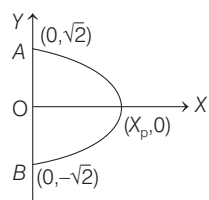

At $x=0, y = \pm\sqrt{2}$

Hence, $(0, \sqrt{2}), (0, -\sqrt{2})$ are the point of intersection of the curve with the Y-axis.

As $x \rightarrow \infty, \int_0^x f(t) dt \rightarrow \infty$ for a particular x (say x_n), then

$$\int_0^x f(t) dt = 2 \text{ and for this value of } x, y = 0$$

The curve is symmetrical about X-axis.

Thus, we have that there must be some x , such that $f(x_n) = 2$.

Thus, $y = mx$ intersects this closed curve for all values of m .

23. Given, $f(x) = \int_1^x [2(t-1)(t-2)^3 + 3(t-1)^2(t-2)^2] dt$

$$\begin{aligned} \therefore f'(x) &= [2(x-1)(x-2)^3 + 3(x-1)^2(x-2)^2] \cdot 1 - 0 \\ &= (x-1)(x-2)^2 [2(x-2) + 3(x-1)] \\ &= (x-1)(x-2)^2 (5x-7) \end{aligned}$$

$$\begin{array}{c} + \quad - \quad + \\ \frac{\quad}{1 \quad 7/5} \end{array}$$

$\therefore f(x)$ attains maximum at $x=1$ and $f(x)$ attains minimum at $x = \frac{7}{5}$.

24. It is given that, for functions $f : R \rightarrow R$

and $F : [0, \pi] \rightarrow R$,

$$F(x) = \int_0^x f(t) dt, \text{ where } f(\pi) = -6$$

$$\Rightarrow F'(\pi) = f(\pi) = -6 \quad \dots (i)$$

Now, $\int_0^\pi (f'(x) + F(x)) \cos x dx$

$$\begin{aligned} &= \int_0^\pi f'(x) \cos x dx + \int_0^\pi F(x) \cos x dx \\ &= [\cos x f(x)]_0^\pi + \int_0^\pi f(x) \sin x dx + \int_0^\pi F(x) \cos x dx \\ &\quad \text{\{by integration by parts\}} \\ &= (-1)(-6) - f(0) + [(\sin x) F(x)]_0^\pi \\ &\quad - \int_0^\pi F(x) \cos x dx + \int_0^\pi F(x) \cos x dx \\ &= 6 - f(0) = 2 \quad \text{(given)} \end{aligned}$$

$$\Rightarrow f(0) = 4$$

Topic 4 Limits as the Sum

1. Let $p = \lim_{n \rightarrow \infty} \left(\frac{(n+1)^{1/3}}{n^{4/3}} + \frac{(n+2)^{1/3}}{n^{4/3}} + \dots + \frac{(2n)^{1/3}}{n^{4/3}} \right)$

$$= \lim_{n \rightarrow \infty} \sum_{r=1}^n \frac{(n+r)^{1/3}}{n^{4/3}}$$

$$= \lim_{n \rightarrow \infty} \sum_{r=1}^n \frac{\left(1 + \frac{r}{n}\right)^{1/3} n^{1/3}}{n^{4/3}} = \lim_{n \rightarrow \infty} \frac{1}{n} \sum_{r=1}^n \left(1 + \frac{r}{n}\right)^{1/3}$$

Now, as per integration as limit of sum.

Let $\frac{r}{n} = x$ and $\frac{1}{n} dx = dx$ [$\because n \rightarrow \infty$]

Then, upper limit of integral is 1 and lower limit of integral is 0.

$$\begin{aligned} \text{So, } p &= \int_0^1 (1+x)^{1/3} dx \left[\because \lim_{n \rightarrow \infty} \frac{1}{n} \sum_{r=1}^n f\left(\frac{r}{n}\right) = \int_0^1 f(x) dx \right] \\ &= \left[\frac{3}{4} (1+x)^{4/3} \right]_0^1 \\ &= \frac{3}{4} (2^{4/3} - 1) = \frac{3}{4} (2)^{4/3} - \frac{3}{4} \end{aligned}$$

2. Clearly,

$$\begin{aligned} \lim_{n \rightarrow \infty} \left(\frac{n}{n^2+1^2} + \frac{n}{n^2+2^2} + \frac{n}{n^2+3^2} + \dots + \frac{1}{5n} \right) \\ &= \lim_{n \rightarrow \infty} \left(\frac{n}{n^2+1^2} + \frac{n}{n^2+2^2} + \frac{n}{n^2+3^2} + \dots + \frac{n}{n^2+(2n)^2} \right) \\ &= \lim_{n \rightarrow \infty} \sum_{r=1}^{2n} \frac{n}{n^2+r^2} \\ &= \lim_{n \rightarrow \infty} \sum_{r=1}^{2n} \frac{1}{1 + \left(\frac{r}{n}\right)^2} \cdot \frac{1}{n} = \int_0^2 \frac{dx}{1+x^2} \\ &= [\tan^{-1} x]_0^2 = \tan^{-1} 2 \end{aligned}$$

3. Let $l = \lim_{n \rightarrow \infty} \left(\frac{(n+1) \cdot (n+2) \dots (3n)}{n^{2n}} \right)^{\frac{1}{n}}$

$$\begin{aligned} &= \lim_{n \rightarrow \infty} \left(\frac{(n+1) \cdot (n+2) \dots (n+2n)}{n^{2n}} \right)^{\frac{1}{n}} \\ &= \lim_{n \rightarrow \infty} \left(\left(\frac{n+1}{n}\right) \left(\frac{n+2}{n}\right) \dots \left(\frac{n+2n}{n}\right) \right)^{\frac{1}{n}} \end{aligned}$$

Taking log on both sides, we get

$$\begin{aligned} \log l &= \lim_{n \rightarrow \infty} \frac{1}{n} \left[\log \left\{ \left(1 + \frac{1}{n}\right) \left(1 + \frac{2}{n}\right) \dots \left(1 + \frac{2n}{n}\right) \right\} \right] \\ \Rightarrow \log l &= \lim_{n \rightarrow \infty} \frac{1}{n} \left[\log \left(1 + \frac{1}{n}\right) + \log \left(1 + \frac{2}{n}\right) + \dots + \log \left(1 + \frac{2n}{n}\right) \right] \\ \Rightarrow \log l &= \lim_{n \rightarrow \infty} \frac{1}{n} \sum_{r=1}^{2n} \log \left(1 + \frac{r}{n}\right) \\ \Rightarrow \log l &= \int_0^2 \log(1+x) dx \\ \Rightarrow \log l &= \left[\log(1+x) \cdot x - \int \frac{1}{1+x} \cdot x dx \right]_0^2 \\ \Rightarrow \log l &= [\log(1+x) \cdot x]_0^2 - \int_0^2 \frac{x+1-1}{1+x} dx \\ \Rightarrow \log l &= 2 \cdot \log 3 - \int_0^2 \left(1 - \frac{1}{1+x}\right) dx \\ \Rightarrow \log l &= 2 \cdot \log 3 - [x - \log |1+x|]_0^2 \end{aligned}$$

328 Definite Integration

$$\Rightarrow \log l = 2 \cdot \log 3 - [2 - \log 3]$$

$$\Rightarrow \log l = 3 \cdot \log 3 - 2$$

$$\Rightarrow \log l = \log 27 - 2$$

$$\therefore l = e^{\log 27 - 2} = 27 \cdot e^{-2} = \frac{27}{e^2}$$

4. Since,

$$\lim_{n \rightarrow \infty} \left[\frac{1 + \sqrt[3]{2} + \sqrt[3]{3} + \dots + \sqrt[3]{n}}{n^{7/3} \left(\frac{1}{(an+1)^2} + \frac{1}{(an+2)^2} + \dots + \frac{1}{(an+n)^2} \right)} \right],$$

$a \in R, |a| > 1$

$$= \lim_{n \rightarrow \infty} \frac{\sum_{r=1}^n (r^{1/3})}{n^{7/3} \sum_{r=1}^n \frac{1}{(an+r)^2}} = \lim_{n \rightarrow \infty} \frac{\sum_{r=1}^n \left(\frac{r}{n}\right)^{1/3} \frac{1}{n}}{\sum_{r=1}^n \frac{1}{\left(a + \frac{r}{n}\right)^2} \frac{1}{n}}$$

$$= \frac{\int_0^1 x^{1/3} dx}{\int_0^1 \frac{dx}{(a+x)^2}} = 54, \quad (\text{given})$$

$$\Rightarrow \frac{\frac{3}{4} [x^{4/3}]_0^1}{\left[-\frac{1}{x+a} \right]_0^1} = 54 \Rightarrow \frac{3/4}{-\frac{1}{a+1} + \frac{1}{a}} = 54$$

$$\Rightarrow \frac{3}{4 \times 54} = \frac{1}{a(a+1)}$$

$$\Rightarrow a^2 + a = 72$$

$$\Rightarrow a^2 + 9a - 8a - 72 = 0$$

$$\Rightarrow a(a+9) - 8(a+9) = 0$$

$$\Rightarrow (a-8)(a+9) = 0$$

$$\Rightarrow a = 8 \text{ or } -9$$

Hence, options (c) and (d) are correct.

5. **PLAN** Converting Infinite series into definite Integral

$$\text{i.e. } \lim_{n \rightarrow \infty} \frac{h(n)}{n}$$

$$\lim_{n \rightarrow \infty} \frac{1}{n} \sum_{r=g(n)}^{h(n)} f\left(\frac{r}{n}\right) = \int f(x) dx$$

$$\lim_{n \rightarrow \infty} \frac{g(n)}{n}$$

where, $\frac{r}{n}$ is replaced with x .

Σ is replaced with integral.

Here,

$$\lim_{n \rightarrow \infty} \frac{1^a + 2^a + \dots + n^a}{(n+1)^{a-1} \{(na+1) + (na+2) + \dots + (na+n)\}} = \frac{1}{60}$$

$$\Rightarrow \lim_{n \rightarrow \infty} \frac{\sum_{r=1}^n r^a}{(n+1)^{a-1} \left[n^2 a + \frac{n(n+1)}{2} \right]} = \frac{1}{60}$$

$$\Rightarrow \lim_{n \rightarrow \infty} \frac{2 \sum_{r=1}^n \left(\frac{r}{n}\right)^a}{\left(1 + \frac{1}{n}\right)^{a-1} \cdot (2na + n + 1)} = \frac{1}{60}$$

$$\Rightarrow \lim_{n \rightarrow \infty} \frac{1}{n} \left(2 \sum_{r=1}^n \left(\frac{r}{n}\right)^a \right) \cdot \lim_{n \rightarrow \infty} \frac{1}{\left(1 + \frac{1}{n}\right)^{a-1} \cdot \left(2a + 1 + \frac{1}{n}\right)} = \frac{1}{60}$$

$$\Rightarrow 2 \int_0^1 (x^a) dx \cdot \frac{1}{1 \cdot (2a+1)} = \frac{1}{60}$$

$$\Rightarrow \frac{2 \cdot [x^{a+1}]_0^1}{(2a+1) \cdot (a+1)} = \frac{1}{60}$$

$$\therefore \frac{2}{(2a+1)(a+1)} = \frac{1}{60} \Rightarrow (2a+1)(a+1) = 120$$

$$\Rightarrow 2a^2 + 3a + 1 - 120 = 0 \Rightarrow 2a^2 + 3a - 119 = 0$$

$$\Rightarrow (2a+17)(a-7) = 0 \Rightarrow a = 7, \frac{-17}{2}$$

6. Given, $S_n = \sum_{k=0}^n \frac{n}{n^2 + kn + k^2}$

$$= \sum_{k=0}^n \frac{1}{n} \cdot \left(\frac{1}{1 + \frac{k}{n} + \frac{k^2}{n^2}} \right) < \lim_{n \rightarrow \infty} \sum_{k=0}^n \frac{1}{n} \left(\frac{1}{1 + \frac{k}{n} + \left(\frac{k}{n}\right)^2} \right)$$

$$= \int_0^1 \frac{1}{1+x+x^2} dx$$

$$= \left[\frac{2}{\sqrt{3}} \tan^{-1} \left(\frac{2}{\sqrt{3}} \left(x + \frac{1}{2} \right) \right) \right]_0^1$$

$$= \frac{2}{\sqrt{3}} \cdot \left(\frac{\pi}{3} - \frac{\pi}{6} \right) = \frac{\pi}{3\sqrt{3}} \quad \text{i.e. } S_n < \frac{\pi}{3\sqrt{3}}$$

Similarly, $T_n > \frac{\pi}{3\sqrt{3}}$

7. $\lim_{n \rightarrow \infty} \left(\frac{1}{n+1} + \frac{1}{n+2} + \dots + \frac{1}{6n} \right) = \sum_{r=1}^{5n} \frac{1}{n+r}$

$$= \lim_{n \rightarrow \infty} \frac{1}{n} \sum_{r=1}^{5n} \frac{1}{\left(1 + \frac{r}{n}\right)}$$

$$= \int_0^5 \frac{dx}{1+x} = [\log(1+x)]_0^5 = \log 6 - \log 1 = \log 6$$

13

Area

Topic 1 Area Based on Geometrical Figures Without Using Integration

Objective Questions I (Only one correct option)

- The area (in sq. units) of the largest rectangle $ABCD$ whose vertices A and B lie on the X -axis and vertices C and D lie on the parabola, $y = x^2 - 1$ below the X -axis, is
(2020 Main, 4 Sep II)
(a) $\frac{4}{3\sqrt{3}}$ (b) $\frac{2}{3\sqrt{3}}$ (c) $\frac{1}{3\sqrt{3}}$ (d) $\frac{4}{3}$
- If the area enclosed between the curves $y = kx^2$ and $x = ky^2$, ($k > 0$), is 1 square unit. Then, k is
(2019 Main, 10 Jan I)
(a) $\sqrt{3}$ (b) $\frac{1}{\sqrt{3}}$ (c) $\frac{2}{\sqrt{3}}$ (d) $\frac{\sqrt{3}}{2}$
- The area (in sq units) of the region $\{(x, y) : y^2 \geq 2x \text{ and } x^2 + y^2 \leq 4x, x \geq 0, y \geq 0\}$ is
(2016 Main)
(a) $\pi - \frac{4}{3}$ (b) $\pi - \frac{8}{3}$
(c) $\pi - \frac{4\sqrt{2}}{3}$ (d) $\frac{\pi}{2} - \frac{2\sqrt{2}}{3}$
- The common tangents to the circle $x^2 + y^2 = 2$ and the parabola $y^2 = 8x$ touch the circle at the points P, Q and the parabola at the points R, S . Then, the area (in sq units) of the quadrilateral $PQRS$ is
(2014 Adv.)
(a) 3 (b) 6 (c) 9 (d) 15
- The area of the equilateral triangle, in which three coins of radius 1 cm are placed, as shown in the figure, is

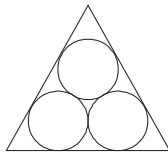

- (2005, 1M)
- (a) $(6 + 4\sqrt{3})$ sq cm (b) $(4\sqrt{3} - 6)$ sq cm
(c) $(7 + 4\sqrt{3})$ sq cm (d) $4\sqrt{3}$ sq cm

- The area of the quadrilateral formed by the tangents at the end points of latusrectum to the ellipse $\frac{x^2}{9} + \frac{y^2}{5} = 1$, is
(2003, 1M)
(a) $27/4$ sq units (b) 9 sq units
(c) $27/2$ sq units (d) 27 sq units
- The area (in sq units) bounded by the curves $y = |x| - 1$ and $y = -|x| + 1$ is
(2002, 2M)
(a) 1 (b) 2
(c) $2\sqrt{2}$ (d) 4
- The triangle formed by the tangent to the curve $f(x) = x^2 + bx - b$ at the point $(1, 1)$ and the coordinate axes, lies in the first quadrant. If its area is 2 sq units, then the value of b is
(2001, 2M)
(a) -1 (b) 3 (c) -3 (d) 1

Objective Question II

(One or more than one correct option)

- Let P and Q be distinct points on the parabola $y^2 = 2x$ such that a circle with PQ as diameter passes through the vertex O of the parabola. If P lies in the first quadrant and the area of ΔOPQ is $3\sqrt{2}$, then which of the following is/are the coordinates of P ?
(2015 Adv.)
(a) $(4, 2\sqrt{2})$ (b) $(9, 3\sqrt{2})$ (c) $(\frac{1}{4}, \frac{1}{\sqrt{2}})$ (d) $(1, \sqrt{2})$

Integer & Numerical Answer Type Questions

- A farmer F_1 has a land in the shape of a triangle with vertices at $P(0, 0)$, $Q(1, 1)$ and $R(2, 0)$. From this land, a neighbouring farmer F_2 takes away the region which lies between the sides PQ and a curve of the form $y = x^n$ ($n > 1$). If the area of the region taken away by the farmer F_2 is exactly 30% of the area of ΔPQR , then the value of n is
- (2018 Adv.)

Fill in the Blanks

11. The area of the triangle formed by the positive X-axis and the normal and the tangent to the circle $x^2 + y^2 = 4$ at $(1, \sqrt{3})$ is (1989, 2M)
12. The area enclosed within the curve $|x| + |y| = 1$ is (1981, 2M)

Analytical & Descriptive Question

13. Let $O(0, 0)$, $A(2, 0)$ and $B(1, \frac{1}{\sqrt{3}})$ be the vertices of a triangle. Let R be the region consisting of all those points P inside ΔOAB which satisfy $d(P, OA) \geq \min\{d(P, OB), d(P, AB)\}$, where d denotes the distance from the point to the corresponding line. Sketch the region R and find its area. (1997C, 5M)

Passage Based Questions

Consider the functions defined implicitly by the equation $y^3 - 3y + x = 0$ on various intervals in the real line. If $x \in (-\infty, -2) \cup (2, \infty)$, the equation implicitly defines a unique real-valued differentiable function

$y = f(x)$. If $x \in (-2, 2)$, the equation implicitly defines a unique real-valued differentiable function $y = g(x)$, satisfying $g(0) = 0$. (2008, M)

14. If $f(-10\sqrt{2}) = 2\sqrt{2}$, then $f''(-10\sqrt{2})$ is equal to
 (a) $\frac{4\sqrt{2}}{7^3 3^2}$ (b) $-\frac{4\sqrt{2}}{7^3 3^2}$ (c) $\frac{4\sqrt{2}}{7^3 3}$ (d) $-\frac{4\sqrt{2}}{7^3 3}$
15. The area of the region bounded by the curve $y = f(x)$, the X-axis and the lines $x = a$ and $x = b$, where $-\infty < a < b < -2$, is
 (a) $\int_a^b \frac{x}{3\{f(x)\}^2 - 1} dx + bf(b) - af(a)$
 (b) $-\int_a^b \frac{x}{3\{f(x)\}^2 - 1} dx + bf(b) - af(a)$
 (c) $\int_a^b \frac{x}{3\{f(x)\}^2 - 1} dx - bf(b) + af(a)$
 (d) $-\int_a^b \frac{x}{3\{f(x)\}^2 - 1} dx - bf(b) + af(a)$
16. $\int_{-1}^1 g'(x) dx$ is equal to
 (a) $2g(-1)$ (b) 0 (c) $-2g(1)$ (d) $2g(1)$

Topic 2 Area Using Integration

Objective Questions I (Only one correct option)

1. Let the functions $f: \mathbf{R} \rightarrow \mathbf{R}$ and $g: \mathbf{R} \rightarrow \mathbf{R}$ be defined by
 $f(x) = e^{x-1} - e^{-x-1}$ and $g(x) = \frac{1}{2}(e^{x-1} + e^{-x-1})$.

Then the area of the region in the first quadrant bounded by the curves $y = f(x)$, $y = g(x)$ and $x = 0$ is (2020 Adv.)

- (a) $(2 - \sqrt{3}) + \frac{1}{2}(e - e^{-1})$ (b) $(2 + \sqrt{3}) + \frac{1}{2}(e - e^{-1})$
 (c) $(2 - \sqrt{3}) + \frac{1}{2}(e + e^{-1})$ (d) $(2 + \sqrt{3}) + \frac{1}{2}(e + e^{-1})$
2. Consider the region $R = \{(x, y) \in \mathbf{R}^2 : x^2 \leq y \leq 2x\}$. If a line $y = \alpha$ divides the area of region R into two equal parts, then which of the following is true? (2020 Main, 2 Sep II)
- (a) $\alpha^3 - 6\alpha^2 + 16 = 0$ (b) $3\alpha^2 - 8\alpha^{3/2} + 8 = 0$
 (c) $3\alpha^2 - 8\alpha + 8 = 0$ (d) $\alpha^3 - 6\alpha^{3/2} - 16 = 0$

3. The area (in sq. units) of the region $A = \{(x, y) : (x-1)[x] \leq y \leq 2\sqrt{x}, 0 \leq x \leq 2\}$, where $[t]$ denotes the greatest integer function, is (2020 Main, 5 Sep II)
- (a) $\frac{8}{3}\sqrt{2} - \frac{1}{2}$ (b) $\frac{4}{3}\sqrt{2} + 1$
 (c) $\frac{8}{3}\sqrt{2} - 1$ (d) $\frac{4}{3}\sqrt{2} - \frac{1}{2}$

4. The area of the region $\{(x, y) : xy \leq 8, 1 \leq y \leq x^2\}$ is (2020 Adv.)
- (a) $8 \log_e 2 - \frac{14}{3}$ (b) $8 \log_e 2 - \frac{7}{3}$
 (c) $16 \log_e 2 - \frac{14}{3}$ (d) $16 \log_e 2 - 6$

5. If the area (in sq units) bounded by the parabola $y^2 = 4\lambda x$ and the line $y = \lambda x$, $\lambda > 0$, is $\frac{1}{9}$, then λ is equal to (2019 Main, 12 April II)
- (a) $2\sqrt{6}$ (b) 48 (c) 24 (d) $4\sqrt{3}$
6. If the area (in sq units) of the region $\{(x, y) : y^2 \leq 4x, x + y \leq 1, x \geq 0, y \geq 0\}$ is $a\sqrt{2} + b$, then $a - b$ is equal to (2019 Main, 12 April I)
- (a) $\frac{10}{3}$ (b) 6 (c) $\frac{8}{3}$ (d) $-\frac{2}{3}$
7. The area (in sq units) of the region bounded by the curves $y = 2^x$ and $y = |x + 1|$, in the first quadrant is (2019 Main, 10 April II)
- (a) $\frac{3}{2}$ (b) $\log_e 2 + \frac{3}{2}$ (c) $\frac{1}{2}$ (d) $\frac{3}{2} - \frac{1}{\log_e 2}$
8. The area (in sq units) of the region $A = \left\{ (x, y) : \frac{y^2}{2} \leq x \leq y + 4 \right\}$ is (2019 Main, 9 April II)
- (a) 30 (b) $\frac{53}{3}$ (c) 16 (d) 18
9. The area (in sq units) of the region $A = \{(x, y) : x^2 \leq y \leq x + 2\}$ is (2019 Main, 9 April I)
- (a) $\frac{13}{6}$ (b) $\frac{9}{2}$ (c) $\frac{31}{6}$ (d) $\frac{10}{3}$
10. Let $S(\alpha) = \{(x, y) : y^2 \leq x, 0 \leq x \leq \alpha\}$ and $A(\alpha)$ is area of the region $S(\alpha)$. If for $\lambda, 0 < \lambda < 4$, $A(\lambda) : A(4) = 2 : 5$, then λ equals (2019 Main, 8 April II)
- (a) $2\left(\frac{4}{25}\right)^{\frac{1}{3}}$ (b) $4\left(\frac{2}{5}\right)^{\frac{1}{3}}$ (c) $4\left(\frac{4}{25}\right)^{\frac{1}{3}}$ (d) $2\left(\frac{2}{5}\right)^{\frac{1}{3}}$

11. The tangent to the parabola $y^2 = 4x$ at the point where it intersects the circle $x^2 + y^2 = 5$ in the first quadrant, passes through the point
 (a) $\left(\frac{1}{4}, \frac{3}{4}\right)$ (b) $\left(\frac{3}{4}, \frac{7}{4}\right)$ (c) $\left(-\frac{1}{3}, \frac{4}{3}\right)$ (d) $\left(-\frac{1}{4}, \frac{1}{2}\right)$
12. The area (in sq units) of the region
 $A = \{(x, y) \in R \times R \mid 0 \leq x \leq 3, 0 \leq y \leq 4, y \leq x^2 + 3x\}$ is
 (2019 Main, 8 April I)
 (a) $\frac{53}{6}$ (b) 8 (c) $\frac{59}{6}$ (d) $\frac{26}{3}$
13. The area (in sq units) of the region bounded by the parabola, $y = x^2 + 2$ and the lines, $y = x + 1, x = 0$ and $x = 3$, is
 (2019 Main, 12 Jan I)
 (a) $\frac{15}{2}$ (b) $\frac{17}{4}$ (c) $\frac{21}{2}$ (d) $\frac{15}{4}$
14. The area (in sq units) in the first quadrant bounded by the parabola, $y = x^2 + 1$, the tangent to it at the point $(2, 5)$ and the coordinate axes is
 (2019 Main, 11 Jan II)
 (a) $\frac{14}{3}$ (b) $\frac{187}{24}$ (c) $\frac{8}{3}$ (d) $\frac{37}{24}$
15. The area (in sq units) of the region bounded by the curve $x^2 = 4y$ and the straight line $x = 4y - 2$ is
 (2019 Main, 11 Jan I)
 (a) $\frac{7}{8}$ (b) $\frac{9}{8}$ (c) $\frac{5}{4}$ (d) $\frac{3}{4}$
16. The area of the region $A = \{(x, y); 0 \leq y \leq x \mid x| + 1 \text{ and } -1 \leq x \leq 1\}$ in sq. units, is
 (2019 Main, 9 Jan II)
 (a) 2 (b) $\frac{4}{3}$ (c) $\frac{1}{3}$ (d) $\frac{2}{3}$
17. The area (in sq units) bounded by the parabola $y = x^2 - 1$, the tangent at the point $(2, 3)$ to it and the Y -axis is
 (2019 Main, 9 Jan I)
 (a) $\frac{8}{3}$ (b) $\frac{56}{3}$ (c) $\frac{32}{3}$ (d) $\frac{14}{3}$
18. Let $g(x) = \cos x^2, f(x) = \sqrt{x}$ and α, β ($\alpha < \beta$) be the roots of the quadratic equation $18x^2 - 9\pi x + \pi^2 = 0$. Then, the area (in sq units) bounded by the curve $y = (g \circ f)(x)$ and the lines $x = \alpha, x = \beta$ and $y = 0$, is
 (2018 Main)
 (a) $\frac{1}{2}(\sqrt{3} - 1)$ (b) $\frac{1}{2}(\sqrt{3} + 1)$
 (c) $\frac{1}{2}(\sqrt{3} - \sqrt{2})$ (d) $\frac{1}{2}(\sqrt{2} - 1)$
19. The area (in sq units) of the region $\{(x, y) : x \geq 0, x + y \leq 3, x^2 \leq 4y \text{ and } y \leq 1 + \sqrt{x}\}$ is
 (2017 Main)
 (a) $\frac{59}{12}$ (b) $\frac{3}{2}$ (c) $\frac{7}{3}$ (d) $\frac{5}{2}$
20. Area of the region $\{(x, y) \in R^2 : y \geq \sqrt{|x+3|}, 5y \leq (x+9) \leq 15\}$ is equal to
 (2016 Adv.)
 (a) $\frac{1}{6}$ (b) $\frac{4}{3}$ (c) $\frac{3}{2}$ (d) $\frac{5}{3}$
21. The area (in sq units) of region described by $(x, y) y^2 \leq 2x$ and $y \geq 4x - 1$ is
 (2015 JEE Main)
 (a) $\frac{7}{32}$ (b) $\frac{5}{64}$ (c) $\frac{15}{64}$ (d) $\frac{9}{32}$
22. The area (in sq units) of the region described by $A = \{(x, y) : x^2 + y^2 \leq 1 \text{ and } y^2 \leq 1 - x\}$ is
 (2014 Main)
 (a) $\frac{\pi}{2} + \frac{4}{3}$ (b) $\frac{\pi}{2} - \frac{4}{3}$ (c) $\frac{\pi}{2} - \frac{2}{3}$ (d) $\frac{\pi}{2} + \frac{2}{3}$
23. The area enclosed by the curves $y = \sin x + \cos x$ and $y = |\cos x - \sin x|$ over the interval $\left[0, \frac{\pi}{2}\right]$ is
 (2014 Adv.)
 (a) $4(\sqrt{2} - 1)$ (b) $2\sqrt{2}(\sqrt{2} - 1)$
 (c) $2(\sqrt{2} + 1)$ (d) $2\sqrt{2}(\sqrt{2} + 1)$
24. The area (in sq units) bounded by the curves $y = \sqrt{x}, 2y - x + 3 = 0, X$ -axis and lying in the first quadrant, is
 (2013 Main, 03)
 (a) 9 (b) 6 (c) 18 (d) $\frac{27}{4}$
25. Let $f : [-1, 2] \rightarrow [0, \infty)$ be a continuous function such that $f(x) = f(1 - x), \forall x \in [-1, 2]$. If $R_1 = \int_{-1}^2 xf(x) dx$ and R_2 are the area of the region bounded by $y = f(x), x = -1, x = 2$ and the X -axis. Then,
 (2011)
 (a) $R_1 = 2R_2$ (b) $R_1 = 3R_2$
 (c) $2R_1 = R_2$ (d) $3R_1 = R_2$
26. If the straight line $x = b$ divide the area enclosed by $y = (1 - x)^2, y = 0$ and $x = 0$ into two parts R_1 ($0 \leq x \leq b$) and R_2 ($b \leq x \leq 1$) such that $R_1 - R_2 = \frac{1}{4}$. Then, b equals
 (2011)
 (a) $\frac{3}{4}$ (b) $\frac{1}{2}$ (c) $\frac{1}{3}$ (d) $\frac{1}{4}$
27. The area of the region between the curves $y = \frac{\sqrt{1 + \sin x}}{\cos x}$ and $y = \frac{\sqrt{1 - \sin x}}{\cos x}$ and bounded by the lines $x = 0$ and $x = \frac{\pi}{4}$ is
 (2008, 3M)
 (a) $\int_0^{\sqrt{2}-1} \frac{t}{(1+t^2)\sqrt{1-t^2}} dt$ (b) $\int_0^{\sqrt{2}-1} \frac{4t}{(1+t^2)\sqrt{1-t^2}} dt$
 (c) $\int_0^{\sqrt{2}+1} \frac{4t}{(1+t^2)\sqrt{1-t^2}} dt$ (d) $\int_0^{\sqrt{2}+1} \frac{t}{(1+t^2)\sqrt{1-t^2}} dt$
28. The area bounded by the curves $y = (x - 1)^2, y = (x + 1)^2$ and $y = \frac{1}{4}$ is
 (2005, 1M)
 (a) $\frac{1}{3}$ sq unit (b) $\frac{2}{3}$ sq unit (c) $\frac{1}{4}$ sq unit (d) $\frac{1}{5}$ sq unit
29. The area enclosed between the curves $y = ax^2$ and $x = ay^2$ ($a > 0$) is 1 sq unit. Then, the value of a is
 (2004, 1M)
 (a) $\frac{1}{\sqrt{3}}$ (b) $\frac{1}{2}$ (c) 1 (d) $\frac{1}{3}$
30. The area bounded by the curves $y = f(x)$, the X -axis and the ordinates $x = 1$ and $x = b$ is $(b - 1) \sin(3b + 4)$. Then, $f(x)$ is equal to
 (1982, 2M)
 (a) $(x - 1) \cos(3x + 4)$
 (b) $8 \sin(3x + 4)$
 (c) $\sin(3x + 4) + 3(x - 1) \cos(3x + 4)$
 (d) None of the above

332 Area

31. The slope of tangent to a curve $y = f(x)$ at $[x, f(x)]$ is $2x + 1$. If the curve passes through the point $(1, 2)$, then the area bounded by the curve, the X-axis and the line $x = 1$ is
- (a) $\frac{3}{2}$ (b) $\frac{4}{3}$ (c) $\frac{5}{6}$ (d) $\frac{1}{12}$

Objective Questions II

(One or more than one correct option)

32. If the line $x = \alpha$ divides the area of region $R = \{(x, y) \in R^2 : x^3 \leq y \leq x, 0 \leq x \leq 1\}$ into two equal parts, then (2017 Adv.)
- (a) $2\alpha^4 - 4\alpha^2 + 1 = 0$ (b) $\alpha^4 + 4\alpha^2 - 1 = 0$
 (c) $\frac{1}{2} < \alpha < 1$ (d) $0 < \alpha \leq \frac{1}{2}$
33. If S be the area of the region enclosed by $y = e^{-x^2}$, $y = 0$, $x = 0$ and $x = 1$. Then, (2012)
- (a) $S \geq \frac{1}{e}$ (b) $S \geq 1 - \frac{1}{e}$
 (c) $S \leq \frac{1}{4} \left(1 + \frac{1}{\sqrt{e}}\right)$ (d) $S \leq \frac{1}{\sqrt{2}} + \frac{1}{\sqrt{e}} \left(1 - \frac{1}{\sqrt{2}}\right)$
34. Area of the region bounded by the curve $y = e^x$ and lines $x = 0$ and $y = e$ is (2009)
- (a) $e - 1$ (b) $\int_1^e \ln(e + 1 - y) dy$
 (c) $e - \int_0^1 e^x dx$ (d) $\int_1^e \ln y dy$
35. For which of the following values of m , is the area of the region bounded by the curve $y = x - x^2$ and the line $y = mx$ equals $\frac{9}{2}$? (1999, 3M)
- (a) -4 (b) -2 (c) 2 (d) 4

Analytical & Descriptive Questions

36. If $\begin{bmatrix} 4a^2 & 4a & 1 \\ 4b^2 & 4b & 1 \\ 4c^2 & 4c & 1 \end{bmatrix} \begin{bmatrix} f(-1) \\ f(1) \\ f(2) \end{bmatrix} = \begin{bmatrix} 3a^2 + 3a \\ 3b^2 + 3b \\ 3c^2 + 3c \end{bmatrix}$,
 $f(x)$ is a quadratic function and its maximum value occurs at a point V . A is a point of intersection of $y = f(x)$ with X-axis and point B is such that chord AB subtends a right angle at V . Find the area enclosed by $f(x)$ and chord AB . (2005, 5M)
37. Find the area bounded by the curves $x^2 = y$, $x^2 = -y$ and $y^2 = 4x - 3$. (2005, 4M)
38. A curve passes through $(2, 0)$ and the slope of tangent at point $P(x, y)$ equals $\frac{(x+1)^2 + y - 3}{(x+1)}$.
 Find the equation of the curve and area enclosed by the curve and the X-axis in the fourth quadrant. (2004, 5M)
39. Find the area of the region bounded by the curves $y = x^2$, $y = |2 - x^2|$ and $y = 2$, which lies to the right of the line $x = 1$. (2002, 5M)

40. Let $b \neq 0$ and for $j = 0, 1, 2, \dots, n$. If S_j is the area of the region bounded by the Y-axis and the curve $xe^{ay} = \sin by$, $\frac{j\pi}{b} \leq y \leq \frac{(j+1)\pi}{b}$. Then, show that $S_0, S_1, S_2, \dots, S_n$ are in geometric progression. Also, find their sum for $a = -1$ and $b = \pi$. (2001, 5M)

41. If $f(x)$ is a continuous function given by

$$f(x) = \begin{cases} 2x, & |x| \leq 1 \\ x^2 + ax + b, & |x| > 1 \end{cases}$$

Then, find the area of the region in the third quadrant bounded by the curves $x = -2y^2$ and $y = f(x)$ lying on the left on the line $8x + 1 = 0$. (1999, 5M)

42. Let C_1 and C_2 be the graphs of functions $y = x^2$ and $y = 2x$, $0 \leq x \leq 1$, respectively. Let C_3 be the graph of a function $y = f(x)$, $0 \leq x \leq 1$, $f(0) = 0$. For a point P on C_1 , let the lines through P , parallel to the axes, meet C_2 and C_3 at Q and R respectively (see figure). If for every position of P (on C_1) the areas of the shaded regions OPQ and ORP are equal, then determine $f(x)$. (1998, 8M)

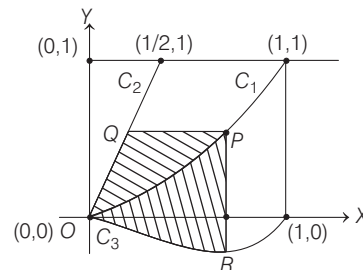

43. Let $f(x) = \max\{x^2, (1-x)^2, 2x(1-x)\}$, where $0 \leq x \leq 1$. Determine the area of the region bounded by the curves $y = f(x)$, X-axis, $x = 0$ and $x = 1$. (1997, 5M)
44. Find all the possible values of $b > 0$, so that the area of the bounded region enclosed between the parabolas $y = x - bx^2$ and $y = \frac{x^2}{b}$ is maximum. (1997C, 5M)
45. If A_n is the area bounded by the curve $y = (\tan x)^n$ and the lines $x = 0$, $y = 0$ and $x = \frac{\pi}{4}$.
 Then, prove that for $n > 2$, $A_n + A_{n+2} = \frac{1}{n+1}$
 and deduce $\frac{1}{2n+2} < A_n < \frac{1}{2n-2}$. (1996, 3M)
46. Consider a square with vertices at $(1, 1)$, $(-1, 1)$, $(-1, -1)$ and $(1, -1)$. If S is the region consisting of all points inside the square which are nearer to the origin than to any edge. Then, sketch the region S and find its area. (1995, 5M)
47. In what ratio, does the X-axis divide the area of the region bounded by the parabolas $y = 4x - x^2$ and $y = x^2 - x$? (1994, 5M)
48. Sketch the region bounded by the curves $y = x^2$ and $y = 2/(1+x^2)$. Find its area. (1992, 4M)

49. Sketch the curves and identify the region bounded by $x = 1/2$, $x = 2$, $y = \log x$ and $y = 2^x$. Find the area of this region. (1991, 4M)
50. Compute the area of the region bounded by the curves $y = ex \log x$ and $y = \frac{\log x}{ex}$, where $\log e = 1$. (1990, 4M)
51. Find all maxima and minima of the function $y = x(x-1)^2$, $0 \leq x \leq 2$.
Also, determine the area bounded by the curve $y = x(x-1)^2$, the Y -axis and the line $x = 2$. (1989, 5M)
52. Find the area of the region bounded by the curve $C: y = \tan x$, tangent drawn to C at $x = \pi/4$ and the X -axis. (1988, 5M)
53. Find the area bounded by the curves $x^2 + y^2 = 25$, $4y = |4 - x^2|$ and $x = 0$ above the X -axis. (1987, 6M)
54. Find the area bounded by the curves $x^2 + y^2 = 4$, $x^2 = -\sqrt{2}y$ and $x = y$. (1986, 5M)
55. Sketch the region bounded by the curves $y = \sqrt{5 - x^2}$ and $y = |x - 1|$ and find its area. (1985, 5M)
56. Find the area of the region bounded by the X -axis and the curves defined by $y = \tan x$, $-\frac{\pi}{3} \leq x \leq \frac{\pi}{3}$ and $y = \cot x$, $\frac{\pi}{6} \leq x \leq \frac{\pi}{3}$. (1984, 4M)
57. Find the area bounded by the X -axis, part of the curve $y = \left(1 + \frac{8}{x^2}\right)$ and the ordinates at $x = 2$ and $x = 4$. If the ordinate at $x = a$ divides the area into two equal parts, then find a . (1983, 3M)
58. Find the area bounded by the curve $x^2 = 4y$ and the straight line $x = 4y - 2$.
59. For any real t , $x = \frac{e^t + e^{-t}}{2}$, $y = \frac{e^t - e^{-t}}{2}$ is a point on the hyperbola $x^2 - y^2 = 1$. Find the area bounded by this hyperbola and the lines joining its centre to the points corresponding to t_1 and $-t_1$. (1982, 3M)

Answers

Topic 1

1. (a) 2. (b) 3. (b) 4. (d)
5. (a) 6. (d) 7. (b) 8. (c)
9. (a,d) 10. (4) 11. $2\sqrt{3}$ sq units
12. 2 sq units 13. $(2 - \sqrt{3})$ sq unit
14. (b) 15. (a) 16. (d)

Topic 2

1. (a) 2. (b) 3. (a) 4. (c)
5. (c) 6. (b) 7. (d) 8. (d)
9. (b) 10. (c) 11. (b) 12. (c)
13. (a) 14. (d) 15. (b) 16. (a)
17. (a) 18. (a) 19. (d) 20. (c)
21. (d) 22. (a) 23. (b) 24. (a)
25. (c) 26. (b) 27. (b) 28. (a)
29. (a) 30. (c) 31. (c) 32. (a, c)
33. (b, d) 34. (b, c, d) 35. (b, d) 36. $\frac{125}{3}$ sq units
37. $\frac{1}{3}$ sq unit 38. $y = x^2 - 2x$, $\frac{4}{3}$ sq units

39. $\left(\frac{20 - 12\sqrt{2}}{3}\right)$ sq units 40. $\left[\frac{\pi(1+e)}{(1+\pi^2)} \cdot \frac{(e^{n+1}-1)}{e-1}\right]$
41. $\left(\frac{761}{192}\right)$ sq units 42. $f(x) = x^3 - x^2$, $0 \leq x \leq 1$
43. $\frac{17}{27}$ sq unit 44. $b = 1$ 46. $\left[\frac{1}{3}(16\sqrt{2} - 20)\right]$ sq units
47. 121 : 4 48. $\left(\pi - \frac{2}{3}\right)$ sq units
49. $\left(\frac{4 - \sqrt{2}}{\log 2} - \frac{5}{2} \log 2 + \frac{3}{2}\right)$ sq units 50. $\left(\frac{e^2 - 5}{4e}\right)$ sq units
51. $\left(y_{\max} = \frac{4}{27}, y_{\min} = 0, \frac{10}{3} \text{ sq units}\right)$
52. $\left[\left(\log \sqrt{2} - \frac{1}{4}\right) \text{ sq units}\right]$ 53. $\left[4 + 25 \sin^{-1}\left(\frac{4}{5}\right)\right]$ sq units
54. $\left(\frac{1}{3} - \pi\right)$ sq units 55. $\left(\frac{5\pi}{4} - \frac{1}{2}\right)$ sq units
56. $\left(\frac{1}{2} \log_e 3\right)$ sq units 57. $2\sqrt{2}$ 58. $\frac{9}{8}$ sq units
59. $\frac{e^{2t_1} - e^{-2t_1}}{4} - \frac{1}{4}(e^{2t_1} - e^{-2t_1} - 4t_1)$

Hints & Solutions

Topic 1 Area Based on Geometrical Figures Without Using Integration

1. Equation of given parabola $y = x^2 - 1$. According to symmetry let, the coordinate of $A(-a, 0)$, $B(a, 0)$, $C(a, a^2 - 1)$ and $D(-a, a^2 - 1)$.
 \therefore Area of rectangle $P(a) = 2a(a^2 - 1)$

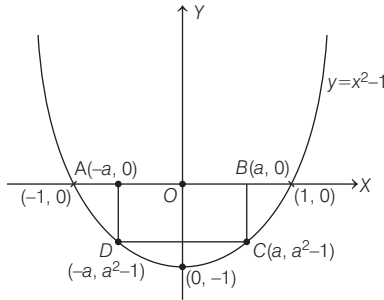

Now, for maxima $P'(a) = 0 \Rightarrow 2(a^2 - 1) + 4a^2 = 0$
 $\Rightarrow 3a^2 = 1 \Rightarrow a = \frac{1}{\sqrt{3}}$ units

\therefore Area of largest rectangle is

$$\left| \frac{2}{\sqrt{3}} \left(\frac{1}{3} - 1 \right) \right| = \frac{4}{3\sqrt{3}} \text{ sq. units}$$

2. We know that, area of region bounded by the parabolas $x^2 = 4ay$ and $y^2 = 4bx$ is $\frac{16}{3}(ab)$ sq units.

On comparing $y = kx^2$ and $x = ky^2$ with above equations, we get $4a = \frac{1}{k}$ and $4b = \frac{1}{k}$

$$\Rightarrow a = \frac{1}{4k} \text{ and } b = \frac{1}{4k}$$

\therefore Area enclosed between $y = kx^2$ and $x = ky^2$ is

$$\frac{16}{3} \left(\frac{1}{4k} \right) \left(\frac{1}{4k} \right) = \frac{1}{3k^2}$$

$$\Rightarrow \frac{1}{3k^2} = 1 \quad [\text{given, area} = 1 \text{ sq. unit}]$$

$$\Rightarrow k^2 = \frac{1}{3} \Rightarrow k = \pm \frac{1}{\sqrt{3}}$$

$$\Rightarrow k = \frac{1}{\sqrt{3}} \quad [\because k > 0]$$

3. Given equations of curves are $y^2 = 2x$

which is a parabola with vertex $(0, 0)$ and axis parallel to X-axis. ..(i)

And $x^2 + y^2 = 4x$

which is a circle with centre $(2, 0)$ and radius = 2 ... (ii)

On substituting $y^2 = 2x$ in Eq. (ii), we get

$$x^2 + 2x = 4x \Rightarrow x^2 = 2x \Rightarrow x = 0 \text{ or } x = 2$$

$$\Rightarrow y = 0 \text{ or } y = \pm 2 \quad [\text{using Eq. (i)}]$$

Now, the required area is the area of shaded region, i.e.

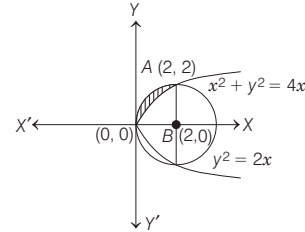

$$\begin{aligned} \text{Required area} &= \frac{\text{Area of a circle}}{4} - \int_0^2 \sqrt{2x} \, dx \\ &= \frac{\pi(2)^2}{4} - \sqrt{2} \int_0^2 x^{1/2} \, dx = \pi - \sqrt{2} \left[\frac{x^{3/2}}{3/2} \right]_0^2 \\ &= \pi - \frac{2\sqrt{2}}{3} [2\sqrt{2} - 0] = \left(\pi - \frac{8}{3} \right) \text{ sq unit} \end{aligned}$$

4. **PLAN** (i) $y = mx + a/m$ is an equation of tangent to the parabola $y^2 = 4ax$.
 (ii) A line is a tangent to circle, if distance of line from centre is equal to the radius of circle.
 (iii) Equation of chord drawn from exterior point (x_1, y_1) to a circle/parabola is given by $T = 0$.
 (iv) Area of trapezium = $\frac{1}{2}$ (Sum of parallel sides)

Let equation of tangent to parabola be $y = mx + \frac{2}{m}$

It also touches the circle $x^2 + y^2 = 2$.

$$\begin{aligned} \therefore \left| \frac{2}{m\sqrt{1+m^2}} \right| &= \sqrt{2} \\ \Rightarrow m^4 + m^2 &= 2 \\ \Rightarrow m^4 + m^2 - 2 &= 0 \\ \Rightarrow (m^2 - 1)(m^2 + 2) &= 0 \\ \Rightarrow m = \pm 1, m^2 = -2 & \quad [\text{rejected } m^2 = -2] \end{aligned}$$

So, tangents are $y = x + 2$, $y = -x - 2$.

They, intersect at $(-2, 0)$.

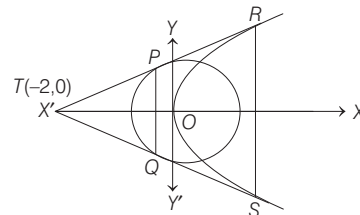

Equation of chord PQ is $-2x = 2 \Rightarrow x = -1$

Equation of chord RS is $O = 4(x - 2) \Rightarrow x = 2$

\therefore Coordinates of P, Q, R, S are

$P(-1, 1), Q(-1, -1), R(2, 4), S(2, -4)$

$$\therefore \text{Area of quadrilateral} = \frac{(2+8) \times 3}{2} = 15 \text{ sq units}$$

5. Since, tangents drawn from external points to the circle subtends equal angle at the centre.

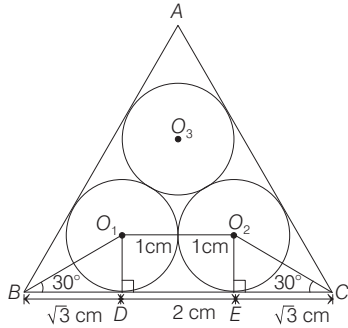

∴ $\angle O_1BD = 30^\circ$
 In ΔO_1BD , $\tan 30^\circ = \frac{O_1D}{BD}$
 $\Rightarrow BD = \sqrt{3}$ cm
 Also, $DE = O_1O_2 = 2$ cm and $EC = \sqrt{3}$ cm
 Now, $BC = BD + DE + EC = 2 + 2\sqrt{3}$
 $\Rightarrow \text{Area of } \Delta ABC = \frac{\sqrt{3}}{4} (BC)^2$
 $= \frac{\sqrt{3}}{4} \cdot 4(1 + \sqrt{3})^2 = (6 + 4\sqrt{3})$ sq cm

6. Given, $\frac{x^2}{9} + \frac{y^2}{5} = 1$

To find tangents at the end points of latusrectum, we find ae .

i.e. $ae = \sqrt{a^2 - b^2} = \sqrt{4} = 2$

and $\sqrt{b^2(1 - e^2)} = \sqrt{5\left(1 - \frac{4}{9}\right)} = \frac{5}{3}$

By symmetry, the quadrilateral is a rhombus.

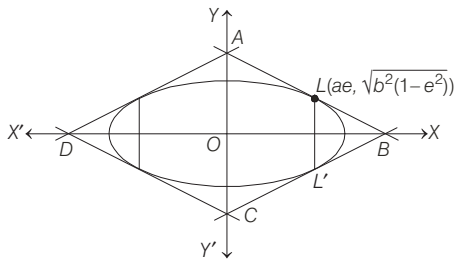

So, area is four times the area of the right angled triangle formed by the tangent and axes in the 1st quadrant.

∴ Equation of tangent at $\left(2, \frac{5}{3}\right)$ is

$$\frac{2}{9}x + \frac{5}{3} \cdot \frac{y}{5} = 1 \Rightarrow \frac{x}{9/2} + \frac{y}{3} = 1$$

∴ Area of quadrilateral ABCD
 $= 4$ [area of ΔAOB]
 $= 4\left(\frac{1}{2} \cdot \frac{9}{2} \cdot 3\right) = 27$ sq units

7. The region is clearly square with vertices at the points (1, 0), (0, 1), (-1, 0) and (0, -1).

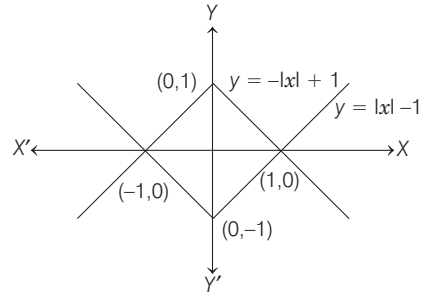

∴ Area of square = $\sqrt{2} \times \sqrt{2} = 2$ sq units

8. Let $y = f(x) = x^2 + bx - b$

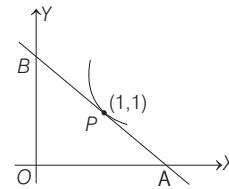

The equation of the tangent at $P(1, 1)$ to the curve $2y = 2x^2 + 2bx - 2b$ is
 $y + 1 = 2x \cdot 1 + b(x + 1) - 2b \Rightarrow y = (2 + b)x - (1 + b)$
 Its meet the coordinate axes at

$$x_A = \frac{1 + b}{2 + b} \quad \text{and} \quad y_B = -(1 + b)$$

∴ Area of $\Delta OAB = \frac{1}{2} OA \times OB$
 $= -\frac{1}{2} \times \frac{(1 + b)^2}{(2 + b)} = 2$ [given]

$\Rightarrow (1 + b)^2 + 4(2 + b) = 0 \Rightarrow b^2 + 6b + 9 = 0$
 $\Rightarrow (b + 3)^2 = 0 \Rightarrow b = -3$

9. Since, $\angle POQ = 90^\circ$

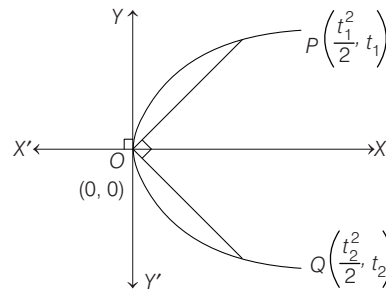

$\Rightarrow \frac{t_1 - 0}{\frac{t_1^2}{2} - 0} \cdot \frac{t_2 - 0}{\frac{t_2^2}{2} - 0} = -1 \Rightarrow t_1 t_2 = -4$... (i)

∴ $\text{ar}(\Delta OPQ) = 3\sqrt{2}$
 $\therefore \frac{1}{2} \begin{vmatrix} 0 & 0 & 1 \\ t_1^2/2 & t_1 & 1 \\ t_2^2/2 & t_2 & 1 \end{vmatrix} = \pm 3\sqrt{2}$
 $\Rightarrow \frac{1}{2} \left(\frac{t_1^2 t_2}{2} - \frac{t_1 t_2^2}{2} \right) = \pm 3\sqrt{2}$

336 Area

$$\Rightarrow \frac{1}{4}(-4t_1 + 4t_2) = \pm 3\sqrt{2} \Rightarrow t_1 + \frac{4}{t_1} = 3\sqrt{2} \quad [\because t_1 > 0 \text{ for } P]$$

$$\Rightarrow t_1^2 - 3\sqrt{2}t_1 + 4 = 0 \Rightarrow (t_1 - 2\sqrt{2})(t_1 - \sqrt{2}) = 0$$

$$\Rightarrow t_1 = \sqrt{2} \text{ or } 2\sqrt{2}$$

$$\therefore P(1, \sqrt{2}) \text{ or } P(4, 2\sqrt{2})$$

- 10.** We have, $y = x^n, n > 1$
 $\therefore P(0, 0), Q(1, 1)$ and $R(2, 0)$ are vertices of ΔPQR .

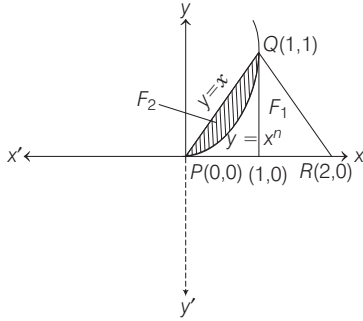

\therefore Area of shaded region = 30% of area of ΔPQR

$$\Rightarrow \int_0^1 (x - x^n) dx = \frac{30}{100} \times \frac{1}{2} \times 2 \times 1$$

$$\Rightarrow \left[\frac{x^2}{2} - \frac{x^{n+1}}{n+1} \right]_0^1 = \frac{3}{10} \Rightarrow \left(\frac{1}{2} - \frac{1}{n+1} \right) = \frac{3}{10}$$

$$\Rightarrow \frac{1}{n+1} = \frac{1}{2} - \frac{3}{10} = \frac{2}{10} = \frac{1}{5} \Rightarrow n+1 = 5 \Rightarrow n = 4$$

- 11.** Equation of tangent at the point $(1, \sqrt{3})$ to the curve $x^2 + y^2 = 4$ is $x + \sqrt{3}y = 4$ whose X-axis intercept $(4, 0)$.

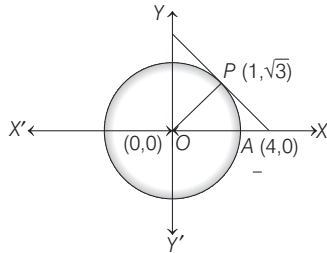

Thus, area of Δ formed by $(0, 0), (1, \sqrt{3})$ and $(4, 0)$

$$= \frac{1}{2} \begin{vmatrix} 0 & 0 & 1 \\ 1 & \sqrt{3} & 1 \\ 4 & 0 & 1 \end{vmatrix} = \frac{1}{2} |(0 - 4\sqrt{3})| = 2\sqrt{3} \text{ sq units}$$

- 12.** The area formed by $|x| + |y| = 1$ is square shown as below :

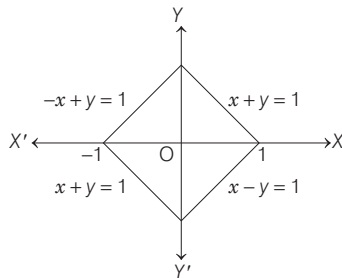

\therefore Area of square = $(\sqrt{2})^2 = 2$ sq units

- 13.** Let the coordinates of P be (x, y) .

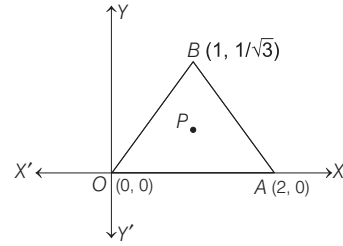

Equation of line OA be $y = 0$.
 Equation of line OB be $\sqrt{3}y = x$.
 Equation of line AB be $\sqrt{3}y = 2 - x$.
 $d(P, OA) =$ Distance of P from line $OA = y$
 $d(P, OB) =$ Distance of P from line $OB = \frac{|\sqrt{3}y - x|}{2}$
 $d(P, AB) =$ Distance of P from line $AB = \frac{|\sqrt{3}y + x - 2|}{2}$
 Given, $d(P, OA) \leq \min \{d(P, OB), d(P, AB)\}$
 $y \leq \min \left\{ \frac{|\sqrt{3}y - x|}{2}, \frac{|\sqrt{3}y + x - 2|}{2} \right\}$

$$\Rightarrow y \leq \frac{|\sqrt{3}y - x|}{2} \text{ and } y \leq \frac{|\sqrt{3}y + x - 2|}{2}$$

Case I When $y \leq \frac{|\sqrt{3}y - x|}{2}$ [since, $\sqrt{3}y - x < 0$]
 $y \leq \frac{x - \sqrt{3}y}{2} \Rightarrow (2 + \sqrt{3})y \leq x \Rightarrow y \leq x \tan 15^\circ$

Case II When $y \leq \frac{|\sqrt{3}y + x - 2|}{2}$,
 $2y \leq 2 - x - \sqrt{3}y$ [since, $\sqrt{3}y + x - 2 < 0$]
 $\Rightarrow (2 + \sqrt{3})y \leq 2 - x \Rightarrow y \leq \tan 15^\circ \cdot (2 - x)$

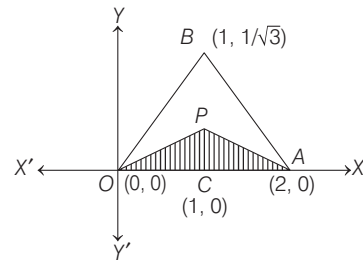

From above discussion, P moves inside the triangle as shown below :

\Rightarrow Area of shaded region
 = Area of ΔOQA
 = $\frac{1}{2}$ (Base) \times (Height)
 = $\frac{1}{2}$ (2) $(\tan 15^\circ) = \tan 15^\circ = (2 - \sqrt{3})$ sq unit

- 14.** Given, $y^3 - 3y + x = 0$
 $\Rightarrow 3y^2 \frac{dy}{dx} - 3 \frac{dy}{dx} + 1 = 0$... (i)

$\Rightarrow 3y^2 \left(\frac{d^2y}{dx^2} \right) + 6y \left(\frac{dy}{dx} \right)^2 - 3 \frac{d^2y}{dx^2} = 0$... (ii)

At $x = -10\sqrt{2}, y = 2\sqrt{2}$

On substituting in Eq. (i) we get

$$3(2\sqrt{2})^2 \cdot \frac{dy}{dx} - 3 \cdot \frac{dy}{dx} + 1 = 0$$

$$\Rightarrow \frac{dy}{dx} = -\frac{1}{21}$$

Again, substituting in Eq. (ii), we get

$$3(2\sqrt{2})^2 \frac{d^2y}{dx^2} + 6(2\sqrt{2}) \cdot \left(-\frac{1}{21}\right)^2 - 3 \cdot \frac{d^2y}{dx^2} = 0$$

$$\Rightarrow 21 \cdot \frac{d^2y}{dx^2} = -\frac{12\sqrt{2}}{(21)^2}$$

$$\Rightarrow \frac{d^2y}{dx^2} = \frac{-12\sqrt{2}}{(21)^3} = \frac{-4\sqrt{2}}{7^3 \cdot 3^2}$$

15. Required area = $\int_a^b y \, dx = \int_a^b f(x) \, dx$

$$= [f(x) \cdot x]_a^b - \int_a^b f'(x)x \, dx$$

$$= bf(b) - af(a) - \int_a^b f'(x)x \, dx$$

$$= bf(b) - af(a) + \int_a^b \frac{xdx}{3\{f(x)\}^2 - 1}$$

$$\left[\because f'(x) = \frac{dy}{dx} = \frac{-1}{3(y^2 - 1)} = \frac{-1}{3\{f(x)\}^2 - 1} \right]$$

16. Let $I = \int_{-1}^1 g'(x) \, dx = [g(x)]_{-1}^1 = g(1) - g(-1)$

Since, $y^3 - 3y + x = 0$... (i)

and $y = g(x)$

$\therefore \{g(x)\}^3 - 3g(x) + x = 0$ [from Eq. (i)]

At $x = 1$, $\{g(1)\}^3 - 3g(1) + 1 = 0$... (ii)

At $x = -1$, $\{g(-1)\}^3 - 3g(-1) - 1 = 0$... (iii)

On adding Eqs. (i) and (ii), we get

$$\{g(1)\}^3 + \{g(-1)\}^3 - 3\{g(1) + g(-1)\} = 0$$

$$\Rightarrow [g(1) + g(-1)]\{g(1)\}^2 + \{g(-1)\}^2 - g(1)g(-1) - 3 = 0$$

$$\Rightarrow g(1) + g(-1) = 0$$

$$\Rightarrow g(1) = -g(-1)$$

$\therefore I = g(1) - g(-1)$

$$= g(1) - \{-g(1)\} = 2g(1)$$

Topic 2 Area Using Integration

1. The given functions $f : R \rightarrow R$ and $g : R \rightarrow R$ be defined by

$$f(x) = e^{x-1} - e^{-|x-1|} = \begin{cases} e^{x-1} - e^{1-x}, & x \geq 1 \\ 0, & x < 1 \end{cases}$$

and $g(x) = \frac{1}{2}(e^{x-1} + e^{1-x})$

For point of intersection of curves $f(x)$ and $g(x)$ put $f(x) = g(x)$

for $x \geq 1$, $e^{x-1} - e^{1-x} = \frac{1}{2}(e^{x-1} + e^{1-x})$

$\Rightarrow e^{x-1} = 3e^{1-x}$

$\Rightarrow e^{2x} = 3e^2 \Rightarrow x = \frac{1}{2} \log_e^3 + 1$

So, required area is

$$\int_0^{1/2 \log_e^3 + 1} (g(x) - f(x)) \, dx$$

$$= \int_0^{1/2 \log_e^3 + 1} g(x) \, dx - \int_1^{1/2 \log_e^3 + 1} f(x) \, dx$$

$$= \frac{1}{2} \int_0^{1/2 \log_e^3 + 1} (e^{x-1} + e^{1-x}) \, dx - \int_1^{1/2 \log_e^3 + 1} (e^{x-1} - e^{1-x}) \, dx$$

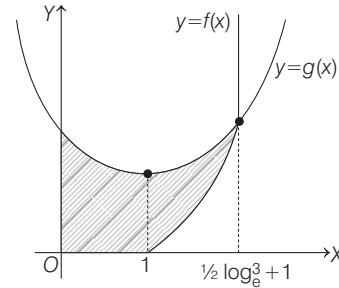

$$= \frac{1}{2} [e^{x-1} - e^{1-x}]_0^{1/2 \log_e^3 + 1} - [e^{x-1} + e^{1-x}]_1^{1/2 \log_e^3 + 1}$$

$$= \frac{1}{2} \left[\sqrt{3} - \frac{1}{\sqrt{3}} - e^{-1} + e \right] - \left[\sqrt{3} + \frac{1}{\sqrt{3}} - 1 - 1 \right]$$

$$= \frac{1}{\sqrt{3}} + \frac{1}{2} (e - e^{-1}) - \frac{4}{\sqrt{3}} + 2 = (2 - \sqrt{3}) + \frac{1}{2} (e - e^{-1})$$

2. According to the question,

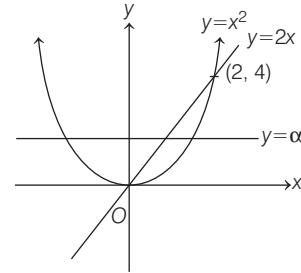

$$\int_0^\alpha \left(\sqrt{y} - \frac{y}{2} \right) dy = \int_\alpha^4 \left(\sqrt{y} - y/2 \right) dy$$

$$\Rightarrow \frac{\alpha \sqrt{\alpha}}{3/2} - \frac{\alpha^2}{4} = \frac{4(2)}{3/2} - \frac{16}{4} - \frac{\alpha \sqrt{\alpha}}{3/2} + \frac{\alpha^2}{4}$$

$$\Rightarrow \frac{4}{3} \alpha \sqrt{\alpha} - \frac{\alpha^2}{2} + \frac{64 - 48}{12} = \frac{16}{12} = \frac{4}{3}$$

$$\Rightarrow 3 \alpha^2 - 8 \alpha^{3/2} + 8 = 0$$

Hence, option (b) is correct.

3. As we know that,

$$y = (x-1)[x] = \begin{cases} 0, & 0 \leq x < 1 \\ x-1, & 1 \leq x < 2 \\ 2(x-1), & x = 2 \end{cases}$$

Now, on drawing the graph of given region with the help of equation of curves $y = (x-1)[x]$ and $y = 2\sqrt{x}$

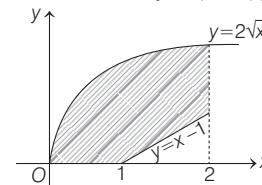

338 Area

∴ Area of given region

$$\begin{aligned}
 &= \int_0^1 2\sqrt{x} \, dx + \int_1^2 (2\sqrt{x} - x + 1) \, dx \\
 &= \left[\frac{4}{3} x^{3/2} \right]_0^1 + \left[\frac{4}{3} x^{3/2} - \frac{x^2}{2} + x \right]_1^2 \\
 &= \frac{4}{3} + \left[\frac{8\sqrt{2}}{3} - 2 + 2 - \frac{4}{3} + \frac{1}{2} - 1 \right] = \frac{8\sqrt{2}}{3} - \frac{1}{2} \text{ sq. units.}
 \end{aligned}$$

4. The given region $\{(x, y) : xy \leq 8, 1 \leq y \leq x^2\}$.

From the figure, region A and B satisfy the given region, but only A is bounded region, so area of bounded region

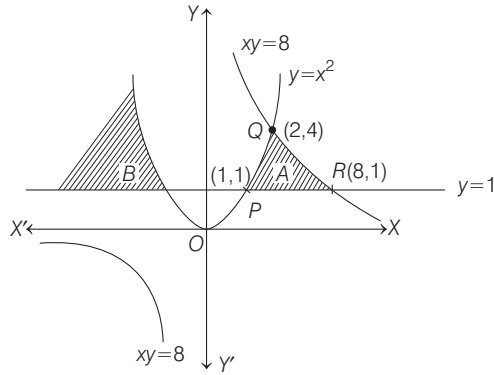

$$A = \int_1^2 (x^2 - 1) \, dx + \int_2^8 \left(\frac{8}{x} - 1 \right) \, dx$$

[∵ Points $P(1, 1)$, $Q(2, 4)$ and

$$\begin{aligned}
 &R(8, 1)] \\
 &= \left[\frac{x^3}{3} - x \right]_1^2 + [8 \log |x| - x]_2^8 \\
 &= \left(\frac{8}{3} - 2 - \frac{1}{3} + 1 \right) + 8 \log 8 - 8 - 8 \log 2 + 2 \\
 &= -\frac{14}{3} + 16 \log 2 = 16 \log 2 - \frac{14}{3}
 \end{aligned}$$

5. Given, equation of curves are

$$y^2 = 4\lambda x \quad \dots(i)$$

and $y = \lambda x \quad \dots(ii)$
 $\lambda > 0$

Area bounded by above two curve is, as per figure

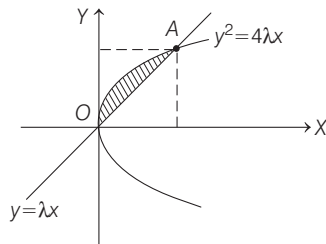

the intersection point A we will get on the solving Eqs. (i) and (ii), we get

$$\lambda^2 x^2 = 4\lambda x \Rightarrow x = \frac{4}{\lambda}, \text{ so } y = 4.$$

So, $A \left(\frac{4}{\lambda}, 4 \right)$

Now, required area is

$$\begin{aligned}
 &= \int_0^{4/\lambda} (2\sqrt{\lambda x} - \lambda x) \, dx \\
 &= 2\sqrt{\lambda} \left[\frac{x^{3/2}}{3/2} \right]_0^{4/\lambda} - \lambda \left[\frac{x^2}{2} \right]_0^{4/\lambda} \\
 &= \frac{4}{3} \sqrt{\lambda} \frac{4\sqrt{4}}{\lambda\sqrt{\lambda}} - \frac{\lambda}{2} \left(\frac{4}{\lambda} \right)^2 \\
 &= \frac{32}{3\lambda} - \frac{8}{\lambda} = \frac{32 - 24}{3\lambda} = \frac{8}{3\lambda}
 \end{aligned}$$

It is given that area = $\frac{1}{9}$

$$\begin{aligned}
 \Rightarrow \quad &\frac{8}{3\lambda} = \frac{1}{9} \\
 \Rightarrow \quad &\lambda = 24
 \end{aligned}$$

6. Given region is $\{(x, y) : y^2 \leq 4x, x + y \leq 1, x \geq 0, y \geq 0\}$

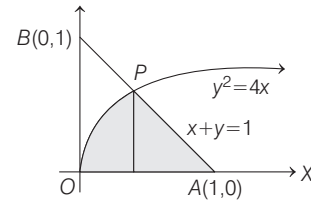

Now, for point P , put value of $y = 1 - x$ to $y^2 = 4x$, we get

$$\begin{aligned}
 (1 - x)^2 &= 4x \Rightarrow x^2 + 1 - 2x = 4x \\
 \Rightarrow \quad &x^2 - 6x + 1 = 0 \\
 \Rightarrow \quad &x = \frac{6 \pm \sqrt{36 - 4}}{2} \\
 &= 3 \pm 2\sqrt{2}.
 \end{aligned}$$

Since, x -coordinate of P less than x -coordinate of point $A(1, 0)$.

$$\therefore x = 3 - 2\sqrt{2}$$

Now, required area

$$\begin{aligned}
 &= \int_0^{3-2\sqrt{2}} 2\sqrt{x} \, dx + \int_{3-2\sqrt{2}}^1 (1 - x) \, dx \\
 &= 2 \left[\frac{x^{3/2}}{3/2} \right]_0^{3-2\sqrt{2}} + \left[x - \frac{x^2}{2} \right]_{3-2\sqrt{2}}^1 \\
 &= \frac{4}{3} (3 - 2\sqrt{2})^{3/2} + \left(1 - \frac{1}{2} \right) - (3 - 2\sqrt{2}) + \frac{(3 - 2\sqrt{2})^2}{2} \\
 &= \frac{4}{3} [(\sqrt{2} - 1)^2]^{3/2} + \frac{1}{2} - 3 + 2\sqrt{2} + \frac{1}{2} (9 + 8 - 12\sqrt{2}) \\
 &= \frac{4}{3} (\sqrt{2} - 1)^3 - \frac{5}{2} + 2\sqrt{2} + \frac{17}{2} - 6\sqrt{2} \\
 &= \frac{4}{3} (2\sqrt{2} - 3(2) + 3(\sqrt{2}) - 1) - 4\sqrt{2} + 6 \\
 &= \frac{4}{3} (5\sqrt{2} - 7) - 4\sqrt{2} + 6 = \frac{8\sqrt{2}}{3} - \frac{10}{3} \\
 &= a\sqrt{2} + b
 \end{aligned}$$

(given)

So, on comparing $a = \frac{8}{3}$ and $b = -\frac{10}{3}$

$$\therefore a - b = \frac{8}{3} + \frac{10}{3} = 6$$

7. Given, equations of curves

$$y = 2^x \text{ and } y = |x + 1| = \begin{cases} x + 1, & x \geq -1 \\ -x - 1, & x < -1 \end{cases}$$

\therefore The figure of above given curves is

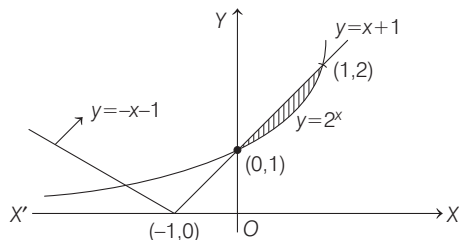

In first quadrant, the above given curves intersect each other at (1, 2).

So, the required area = $\int_0^1 ((x + 1) - 2^x) dx$

$$\begin{aligned} &= \left[\frac{x^2}{2} + x - \frac{2^x}{\log_e 2} \right]_0^1 \quad \left[\because \int a^x dx = \frac{a^x}{\log_e a} + C \right] \\ &= \left[\frac{1}{2} + 1 - \frac{2}{\log_e 2} + \frac{1}{\log_e 2} \right] \\ &= \frac{3}{2} - \frac{1}{\log_e 2} \end{aligned}$$

8. Given region $A = \left\{ (x, y) : \frac{y^2}{2} \leq x \leq y + 4 \right\}$

$$\therefore \frac{y^2}{2} = x$$

$$\Rightarrow y^2 = 2x \quad \dots(i)$$

$$\text{and } x = y + 4 \Rightarrow y = x - 4 \quad \dots(ii)$$

Graphical representation of A is

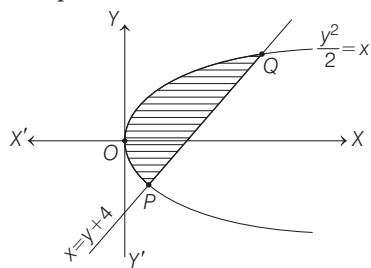

On substituting $y = x - 4$ from Eq. (ii) to Eq. (i), we get

$$\begin{aligned} &(x - 4)^2 = 2x \\ \Rightarrow &x^2 - 8x + 16 = 2x \\ \Rightarrow &x^2 - 10x + 16 = 0 \\ \Rightarrow &(x - 2)(x - 8) = 0 \\ \Rightarrow &x = 2, 8 \\ \therefore &y = -2, 4 \quad \text{[from Eq. (ii)]} \end{aligned}$$

So, the point of intersection of Eqs. (i) and (ii) are $P(2, -2)$ and $Q(8, 4)$.

Now, the area enclosed by the region A

$$\begin{aligned} &= \int_{-2}^4 \left[(y + 4) - \frac{y^2}{2} \right] dy = \left[\frac{y^2}{2} + 4y - \frac{y^3}{6} \right]_{-2}^4 \\ &= \left(\frac{16}{2} + 16 - \frac{64}{6} \right) - \left(\frac{4}{2} - 8 + \frac{8}{6} \right) \\ &= 8 + 16 - \frac{32}{3} - 2 + 8 - \frac{4}{3} = 30 - 12 = 18 \text{ sq unit.} \end{aligned}$$

9. Given region is $A = \{(x, y) : x^2 \leq y \leq x + 2\}$

Now, the region is shown in the following graph

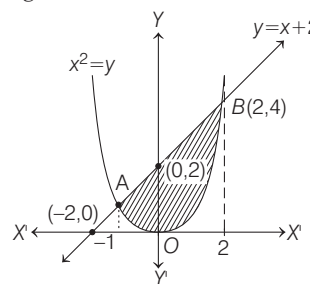

For intersecting points A and B

$$\begin{aligned} \text{Taking, } &x^2 = x + 2 \Rightarrow x^2 - x - 2 = 0 \\ \Rightarrow &x^2 - 2x + x - 2 = 0 \\ \Rightarrow &x(x - 2) + 1(x - 2) = 0 \\ \Rightarrow &x = -1, 2 \Rightarrow y = 1, 4 \end{aligned}$$

So, $A(-1, 1)$ and $B(2, 4)$.

Now, shaded area = $\int_{-1}^2 [(x + 2) - x^2] dx$

$$\begin{aligned} &= \left[\frac{x^2}{2} + 2x - \frac{x^3}{3} \right]_{-1}^2 = \left(\frac{4}{2} + 4 - \frac{8}{3} \right) - \left(\frac{1}{2} - 2 + \frac{1}{3} \right) \\ &= 8 - \frac{1}{2} - \frac{9}{3} = 8 - \frac{1}{2} - 3 = 5 - \frac{1}{2} = \frac{9}{2} \text{ sq units} \end{aligned}$$

10. Given, $S(\alpha) = \{(x, y) : y^2 \leq x, 0 \leq x \leq \alpha\}$ and $A(\alpha)$ is area of the region $S(\alpha)$

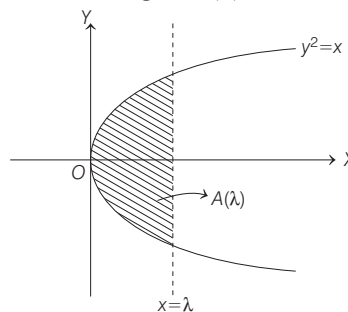

$$\text{Clearly, } A(\lambda) = 2 \int_0^\lambda \sqrt{x} dx = 2 \left[\frac{x^{3/2}}{3/2} \right]_0^\lambda = \frac{4}{3} \lambda^{3/2}$$

$$\text{Since, } \frac{A(\lambda)}{A(4)} = \frac{2}{5}, \quad (0 < \lambda < 4)$$

$$\Rightarrow \frac{\lambda^{3/2}}{4^{3/2}} = \frac{2}{5} \Rightarrow \left(\frac{\lambda}{4} \right)^3 = \left(\frac{2}{5} \right)^2$$

$$\Rightarrow \frac{\lambda}{4} = \left(\frac{4}{25} \right)^{1/3} \Rightarrow \lambda = 4 \left(\frac{4}{25} \right)^{1/3}$$

340 Area

11. Given equations of the parabola $y^2 = 4x$... (i)
and circle $x^2 + y^2 = 5$... (ii)

So, for point of intersection of curves (i) and (ii), put $y^2 = 4x$ in Eq. (ii), we get

$$\begin{aligned} x^2 + 4x - 5 &= 0 \\ \Rightarrow x^2 + 5x - x - 5 &= 0 \\ \Rightarrow (x-1)(x+5) &= 0 \\ \Rightarrow x &= 1, -5 \end{aligned}$$

For first quadrant $x = 1$, so $y = 2$.

Now, equation of tangent of parabola (i) at point (1, 2) is $T = 0$

$$\Rightarrow 2y = 2(x+1) \Rightarrow x - y + 1 = 0$$

The point $\left(\frac{3}{4}, \frac{7}{4}\right)$ satisfies, the equation of line

$$x - y + 1 = 0$$

12. Given, $y \leq x^2 + 3x$

$$\Rightarrow y \leq \left(x + \frac{3}{2}\right)^2 - \frac{9}{4} \Rightarrow \left(x + \frac{3}{2}\right)^2 \geq \left(y + \frac{9}{4}\right)$$

Since, $0 \leq y \leq 4$ and $0 \leq x \leq 3$

\therefore The diagram for the given inequalities is

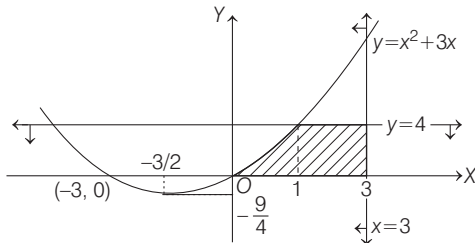

and points of intersection of curves $y = x^2 + 3x$ and $y = 4$ are (1, 4) and (-4, 4)

Now required area

$$\begin{aligned} &= \int_0^1 (x^2 + 3x) dx + \int_1^3 4 dx = \left[\frac{x^3}{3} + \frac{3x^2}{2} \right]_0^1 + [4x]_1^3 \\ &= \frac{1}{3} + \frac{3}{2} + 4(3-1) = \frac{2+9}{6} + 8 = \frac{11}{6} + 8 = \frac{59}{6} \text{ sq units} \end{aligned}$$

13. Given equation of parabola is $y = x^2 + 2$, and the line is $y = x + 1$

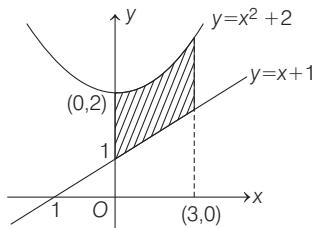

The required area = area of shaded region

$$\begin{aligned} &= \int_0^3 ((x^2 + 2) - (x + 1)) dx = \int_0^3 (x^2 - x + 1) dx \\ &= \left[\frac{x^3}{3} - \frac{x^2}{2} + x \right]_0^3 = \left(\frac{27}{3} - \frac{9}{2} + 3 \right) - 0 \\ &= 9 - \frac{9}{2} + 3 = 12 - \frac{9}{2} = \frac{15}{2} \text{ sq units} \end{aligned}$$

14. Given, equation of parabola is $y = x^2 + 1$, which can be written as $x^2 = (y - 1)$. Clearly, vertex of parabola is (0, 1) and it will open upward.

Now, equation of tangent at (2, 5) is $\frac{y+5}{2} = 2x+1$

[\because Equation of the tangent at (x_1, y_1) is given by $T = 0$. Here, $\frac{1}{2}(y + y_1) = xx_1 + 1$]

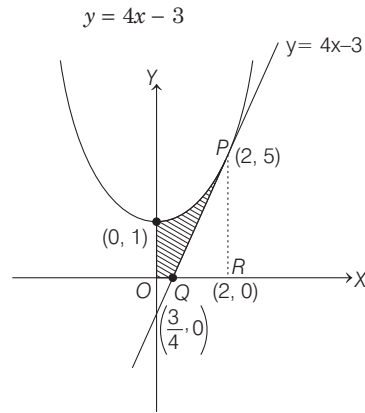

Required area = Area of shaded region

$$= \int_0^2 y(\text{parabola}) dx - (\text{Area of } \Delta PQR)$$

$$= \int_0^2 (x^2 + 1) dx - (\text{Area of } \Delta PQR)$$

$$= \left(\frac{x^3}{3} + x \right)_0^2 - \frac{1}{2} \left(2 - \frac{3}{4} \right) \cdot 5$$

[\because Area of a triangle = $\frac{1}{2} \times \text{base} \times \text{height}$]

$$= \left(\frac{8}{3} + 2 \right) - 0 - \frac{1}{2} \left(\frac{5}{4} \right) \cdot 5$$

$$= \frac{14}{3} - \frac{25}{8} = \frac{112 - 75}{24} = \frac{37}{24}$$

15. Given equation of curve is $x^2 = 4y$, which represent a parabola with vertex (0, 0) and it open upward.

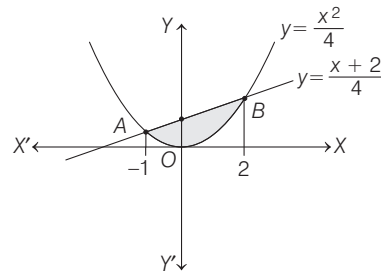

Now, let us find the points of intersection of $x^2 = 4y$ and $4y = x + 2$

$$\begin{aligned} \text{For this consider, } x^2 &= x + 2 \Rightarrow x^2 - x - 2 = 0 \\ \Rightarrow (x-2)(x+1) &= 0 \Rightarrow x = -1, x = 2 \end{aligned}$$

When $x = -1$, then $y = \frac{1}{4}$

and when $x = 2$, then $y = 1$

Thus, the points of intersection are $A\left(-1, \frac{1}{4}\right)$ and $B(2, 1)$.

Now, required area = area of shaded region

$$\begin{aligned} &= \int_{-1}^2 \{y(\text{line}) - y(\text{parabola})\} dx \\ &= \int_{-1}^2 \left(\frac{x+2}{4} - \frac{x^2}{4} \right) dx = \frac{1}{4} \left[\frac{x^2}{2} + 2x - \frac{x^3}{3} \right]_{-1}^2 \\ &= \frac{1}{4} \left[\left(2 + 4 - \frac{8}{3} \right) - \left(\frac{1}{2} - 2 + \frac{1}{3} \right) \right] \\ &= \frac{1}{4} \left[8 - \frac{1}{2} - 3 \right] = \frac{1}{4} \left[5 - \frac{1}{2} \right] = \frac{9}{8} \text{ sq units.} \end{aligned}$$

16. We have,

$$A = \{(x, y) : 0 \leq y \leq x | x| + 1 \text{ and } -1 \leq x \leq 1\}$$

When $x \geq 0$, then $0 \leq y \leq x^2 + 1$

and when $x < 0$, then $0 \leq y \leq -x^2 + 1$

Now, the required region is the shaded region.

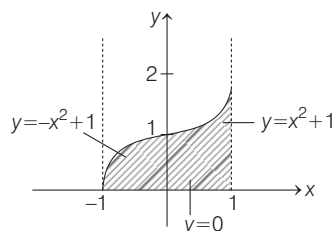

[$\because y = x^2 + 1 \Rightarrow x^2 = (y - 1)$, parabola with vertex $(0, 1)$ and $y = -x^2 + 1 \Rightarrow x^2 = -(y - 1)$,

parabola with vertex $(0, 1)$ but open downward]

We need to calculate the shaded area, which is equal to

$$\begin{aligned} &\int_{-1}^0 (-x^2 + 1) dx + \int_0^1 (x^2 + 1) dx \\ &= \left[-\frac{x^3}{3} + x \right]_{-1}^0 + \left[\frac{x^3}{3} + x \right]_0^1 \\ &= \left(0 - \left[-\frac{(-1)^3}{3} + (-1) \right] \right) + \left(\left[\frac{1}{3} + 1 \right] - 0 \right) \\ &= -\left(\frac{1}{3} - 1 \right) + \frac{4}{3} = \frac{2}{3} + \frac{4}{3} = 2 \end{aligned}$$

17. Given, equation of parabola is $y = x^2 - 1$, which can be rewritten as $x^2 = y + 1$ or $x^2 = (y - (-1))$.

\Rightarrow Vertex of parabola is $(0, -1)$ and it is open upward.

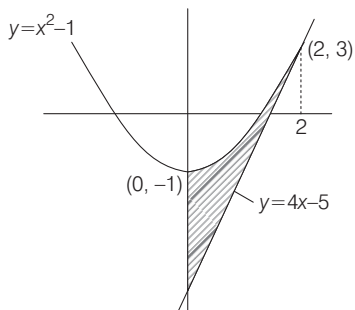

Equation of tangent at $(2, 3)$ is given by $T = 0$

$$\Rightarrow \frac{y + y_1}{2} = x x_1 - 1, \text{ where, } x_1 = 2$$

and $y_1 = 3$.

$$\Rightarrow \frac{y + 3}{2} = 2x - 1 \Rightarrow y = 4x - 5$$

Now, required area = area of shaded region

$$\begin{aligned} &= \int_0^2 (y(\text{parabola}) - y(\text{tangent})) dx \\ &= \int_0^2 [(x^2 - 1) - (4x - 5)] dx \\ &= \int_0^2 (x^2 - 4x + 4) dx = \int_0^2 (x - 2)^2 dx \\ &= \left| \frac{(x - 2)^3}{3} \right|_0^2 = \frac{(2 - 2)^3}{3} - \frac{(0 - 2)^3}{3} = \frac{8}{3} \text{ sq units.} \end{aligned}$$

18. We have,

$$\begin{aligned} &\Rightarrow 18x^2 - 9\pi x + \pi^2 = 0 \\ &\Rightarrow 18x^2 - 6\pi x - 3\pi x + \pi^2 = 0 \\ &\quad (6x - \pi)(3x - \pi) = 0 \end{aligned}$$

$$\Rightarrow x = \frac{\pi}{6}, \frac{\pi}{3}$$

Now, $\alpha < \beta$

$$\begin{aligned} \alpha &= \frac{\pi}{6}, \\ \beta &= \frac{\pi}{3} \end{aligned}$$

Given, $g(x) = \cos x^2$ and $f(x) = \sqrt{x}$

$$y = g \circ f(x)$$

$$\therefore y = g(f(x)) = \cos x$$

Area of region bounded by $x = \alpha, x = \beta, y = 0$ and curve $y = g(f(x))$ is

$$\begin{aligned} A &= \int_{\pi/6}^{\pi/3} \cos x dx \\ A &= [\sin x]_{\pi/6}^{\pi/3} \\ A &= \sin \frac{\pi}{3} - \sin \frac{\pi}{6} = \frac{\sqrt{3}}{2} - \frac{1}{2} \\ A &= \left(\frac{\sqrt{3} - 1}{2} \right) \end{aligned}$$

19. Required area

$$= \int_0^1 (1 + \sqrt{x}) dx + \int_1^2 (3 - x) dx - \int_0^2 \frac{x^2}{4} dx$$

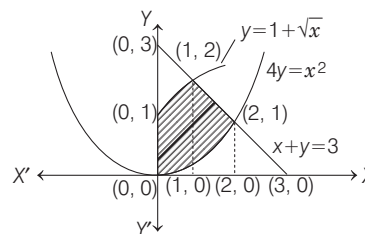

$$\begin{aligned} &= \left[x + \frac{x^{3/2}}{3/2} \right]_0^1 + \left[3x - \frac{x^2}{2} \right]_1^2 - \left[\frac{x^3}{12} \right]_0^2 \\ &= \left(1 + \frac{2}{3} \right) + \left(6 - 2 - 3 + \frac{1}{2} \right) - \left(\frac{8}{12} \right) \\ &= \frac{5}{3} + \frac{3}{2} - \frac{2}{3} = 1 + \frac{3}{2} = \frac{5}{2} \text{ sq units} \end{aligned}$$

342 Area

20. Here, $\{(x, y) \in R^2 : y \geq \sqrt{|x+3|}, 5y \leq (x+9) \leq 15\}$

$$\begin{aligned} \therefore y &\geq \sqrt{x+3} \\ \Rightarrow y &\geq \begin{cases} \sqrt{x+3}, & \text{when } x \geq -3 \\ \sqrt{-x-3}, & \text{when } x \leq -3 \end{cases} \\ \text{or } y^2 &\geq \begin{cases} x+3, & \text{when } x \geq -3 \\ -3-x, & \text{when } x \leq -3 \end{cases} \end{aligned}$$

Shown as

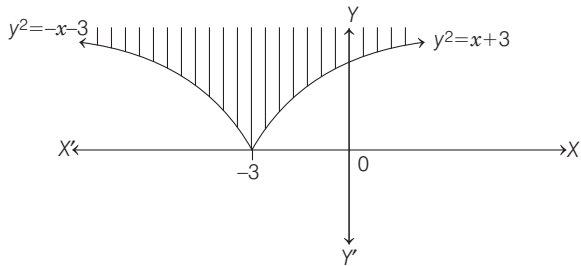

Also, $5y \leq (x+9) \leq 15$
 $\Rightarrow (x+9) \geq 5y$ and $x \leq 6$

Shown as

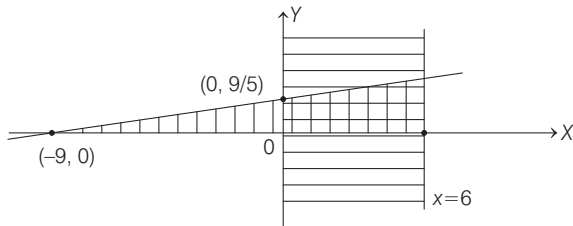

$\therefore \{(x, y) \in R^2 : y \geq \sqrt{|x+3|}, 5y \leq (x+9) \leq 15\}$

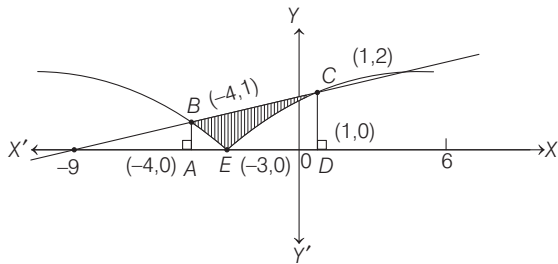

$$\begin{aligned} \therefore \text{Required area} &= \text{Area of trapezium } ABCD \\ &\quad - \text{Area of } ABE \text{ under parabola} \\ &\quad - \text{Area of } CDE \text{ under parabola} \\ &= \frac{1}{2} (1+2) (5) - \int_{-4}^{-3} \sqrt{-(x+3)} dx - \int_{-3}^1 \sqrt{x+3} dx \\ &= \frac{15}{2} - \left[\frac{(-3-x)^{3/2}}{-\frac{3}{2}} \right]_{-4}^{-3} - \left[\frac{(x+3)^{3/2}}{\frac{3}{2}} \right]_{-3}^1 \\ &= \frac{15}{2} + \frac{2}{3} [0-1] - \frac{2}{3} [8-0] = \frac{15}{2} - \frac{2}{3} - \frac{16}{3} = \frac{15}{2} - \frac{18}{3} = \frac{3}{2} \end{aligned}$$

21. Given region is $\{(x, y) : y^2 \leq 2x \text{ and } y \geq 4x-1\}$

$y^2 \leq 2x$ represents a region inside the parabola $y^2 = 2x$... (i)

and $y \geq 4x-1$ represents a region to the left of the line $y = 4x-1$... (ii)

The point of intersection of the curves (i) and (ii) is

$$\begin{aligned} (4x-1)^2 &= 2x \\ \Rightarrow 16x^2 + 1 - 8x &= 2x \\ \Rightarrow 16x^2 - 10x + 1 &= 0 \\ \Rightarrow x &= \frac{1}{2}, \frac{1}{8} \end{aligned}$$

So, the points where these curves intersect are $(\frac{1}{2}, 1)$ and $(\frac{1}{8}, \frac{1}{2})$.

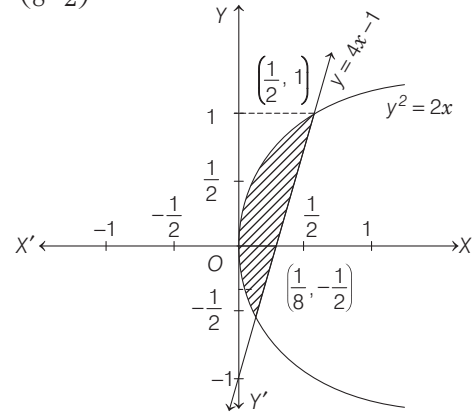

$$\begin{aligned} \therefore \text{Required area} &= \int_{-1/2}^1 \left(\frac{y+1}{4} - \frac{y^2}{2} \right) dy \\ &= \frac{1}{4} \left(\frac{y^2}{2} + y \right)_{-1/2}^1 - \frac{1}{6} (y^3)_{-1/2}^1 \\ &= \frac{1}{4} \left\{ \left(\frac{1}{2} + 1 \right) - \left(\frac{1}{8} - \frac{1}{2} \right) \right\} - \frac{1}{6} \left\{ 1 + \frac{1}{8} \right\} \\ &= \frac{1}{4} \left\{ \frac{3}{2} + \frac{3}{8} \right\} - \frac{1}{6} \left\{ \frac{9}{8} \right\} \\ &= \frac{1}{4} \times \frac{15}{8} - \frac{3}{16} = \frac{9}{32} \text{ sq units} \end{aligned}$$

22. Given, $A = \{(x, y) : x^2 + y^2 \leq 1 \text{ and } y^2 \leq 1-x\}$

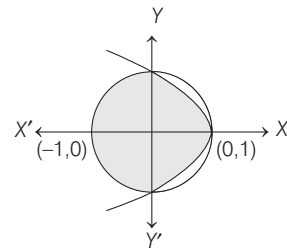

$$\begin{aligned} \text{Required area} &= \frac{1}{2} \pi r^2 + 2 \int_0^1 (1-y^2) dy \\ &= \frac{1}{2} \pi (1)^2 + 2 \left(y - \frac{y^3}{3} \right)_0^1 \\ &= \left(\frac{\pi}{2} + \frac{4}{3} \right) \text{ sq units} \end{aligned}$$

- 23. PLAN** To find the bounded area between $y = f(x)$ and $y = g(x)$ between $x = a$ to $x = b$.

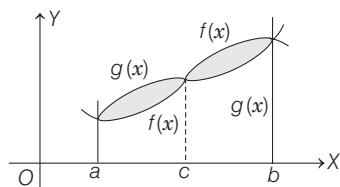

$$\begin{aligned} \therefore \text{Area bounded} &= \int_a^c [g(x) - f(x)] dx + \int_c^b [f(x) - g(x)] dx \\ &= \int_a^b |f(x) - g(x)| dx \end{aligned}$$

Here, $f(x) = y = \sin x + \cos x$, when $0 \leq x \leq \frac{\pi}{2}$

and $g(x) = y = |\cos x - \sin x|$

$$= \begin{cases} \cos x - \sin x, & 0 \leq x \leq \frac{\pi}{4} \\ \sin x - \cos x, & \frac{\pi}{4} \leq x \leq \frac{\pi}{2} \end{cases}$$

could be shown as

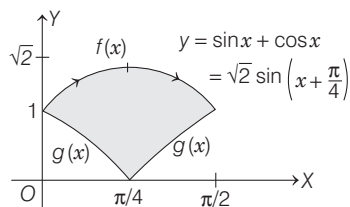

$$\begin{aligned} \therefore \text{Area bounded} &= \int_0^{\pi/4} \{(\sin x + \cos x) - (\cos x - \sin x)\} dx \\ &\quad + \int_{\pi/4}^{\pi/2} \{(\sin x + \cos x) - (\sin x - \cos x)\} dx \\ &= \int_0^{\pi/4} 2 \sin x dx + \int_{\pi/4}^{\pi/2} 2 \cos x dx \\ &= -2 [\cos x]_0^{\pi/4} + 2 [\sin x]_{\pi/4}^{\pi/2} \\ &= 4 - 2\sqrt{2} = 2\sqrt{2}(\sqrt{2} - 1) \text{ sq units} \end{aligned}$$

- 24.** Given curves are $y = \sqrt{x}$... (i)

and $2y - x + 3 = 0$... (ii)

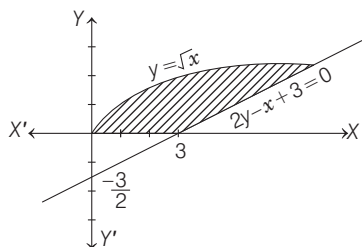

On solving Eqs. (i) and (ii), we get

$$\begin{aligned} 2\sqrt{x} - (\sqrt{x})^2 + 3 &= 0 \\ \Rightarrow (\sqrt{x})^2 - 2\sqrt{x} - 3 &= 0 \\ \Rightarrow (\sqrt{x} - 3)(\sqrt{x} + 1) &= 0 \Rightarrow \sqrt{x} = 3 \\ &\quad [\text{since, } \sqrt{x} = -1 \text{ is not possible}] \\ \therefore y &= 3 \end{aligned}$$

Hence, required area

$$\begin{aligned} &= \int_0^3 (x_2 - x_1) dy = \int_0^3 \{(2y + 3) - y^2\} dy \\ &= \left[y^2 + 3y - \frac{y^3}{3} \right]_0^3 = 9 + 9 - 9 = 9 \text{ sq units} \end{aligned}$$

- 25.** $R_1 = \int_{-1}^2 x f(x) dx$... (i)

Using $\int_a^b f(x) dx = \int_a^b f(a + b - x) dx$

$$R_1 = \int_{-1}^2 (1 - x) f(1 - x) dx$$

- $\therefore R_1 = \int_{-1}^2 (1 - x) f(x) dx$... (ii)

[$f(x) = f(1 - x)$, given]

Given, R_2 is area bounded by $f(x)$, $x = -1$ and $x = 2$.

- $\therefore R_2 = \int_{-1}^2 f(x) dx$... (iii)

On adding Eqs. (i) and (ii), we get

$$2R_1 = \int_{-1}^2 f(x) dx \quad \dots \text{(iv)}$$

From Eqs. (iii) and (iv), we get

$$2R_1 = R_2$$

- 26.** Here, area between 0 to b is R_1 and b to 1 is R_2 .

$$\begin{aligned} \therefore \int_0^b (1 - x)^2 dx - \int_b^1 (1 - x)^2 dx &= \frac{1}{4} \\ \Rightarrow \left[\frac{(1 - x)^3}{-3} \right]_0^b - \left[\frac{(1 - x)^3}{-3} \right]_b^1 &= \frac{1}{4} \\ \Rightarrow -\frac{1}{3} [(1 - b)^3 - 1] + \frac{1}{3} [0 - (1 - b)^3] &= \frac{1}{4} \\ \Rightarrow -\frac{2}{3} (1 - b)^3 = -\frac{1}{3} + \frac{1}{4} = -\frac{1}{12} \Rightarrow (1 - b)^3 &= \frac{1}{8} \\ \Rightarrow (1 - b) = \frac{1}{2} \Rightarrow b = \frac{1}{2} \end{aligned}$$

- 27.** Required area = $\int_0^{\pi/4} \left(\sqrt{\frac{1 + \sin x}{\cos x}} - \sqrt{\frac{1 - \sin x}{\cos x}} \right) dx$

$$\begin{aligned} &\left[\because \frac{1 + \sin x}{\cos x} > \frac{1 - \sin x}{\cos x} > 0 \right] \\ &= \int_0^{\pi/4} \left(\sqrt{\frac{1 + \frac{2 \tan \frac{x}{2}}{1 + \tan^2 \frac{x}{2}}}{1 - \tan^2 \frac{x}{2}}} - \sqrt{\frac{1 - \frac{2 \tan \frac{x}{2}}{1 + \tan^2 \frac{x}{2}}}{1 - \tan^2 \frac{x}{2}}} \right) dx \\ &= \int_0^{\pi/4} \left(\sqrt{\frac{1 + \tan \frac{x}{2}}{1 - \tan \frac{x}{2}}} - \sqrt{\frac{1 - \tan \frac{x}{2}}{1 + \tan \frac{x}{2}}} \right) dx \end{aligned}$$

344 Area

$$= \int_0^{\pi/4} \frac{1 + \tan \frac{x}{2} - 1 + \tan \frac{x}{2}}{\sqrt{1 - \tan^2 \frac{x}{2}}} dx = \int_0^{\pi/4} \frac{2 \tan \frac{x}{2}}{\sqrt{1 - \tan^2 \frac{x}{2}}} dx$$

Put $\tan \frac{x}{2} = t \Rightarrow \frac{1}{2} \sec^2 \frac{x}{2} dx = dt = \int_0^{\tan \frac{\pi}{8}} \frac{4t dt}{(1+t^2)\sqrt{1-t^2}}$

As $\int_0^{\sqrt{2}-1} \frac{4t dt}{(1+t^2)\sqrt{1-t^2}} \quad [\because \tan \frac{\pi}{8} = \sqrt{2}-1]$

28. The curves $y = (x-1)^2$, $y = (x+1)^2$ and $y = 1/4$ are shown as

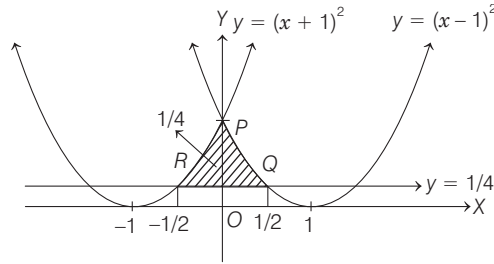

where, points of intersection are

$$(x-1)^2 = \frac{1}{4} \Rightarrow x = \frac{1}{2}$$

and $(x+1)^2 = \frac{1}{4} \Rightarrow x = -\frac{1}{2}$

i.e. $Q\left(\frac{1}{2}, \frac{1}{4}\right)$ and $R\left(-\frac{1}{2}, \frac{1}{4}\right)$

$$\begin{aligned} \therefore \text{Required area} &= 2 \int_0^{1/2} \left[(x-1)^2 - \frac{1}{4} \right] dx \\ &= 2 \left[\frac{(x-1)^3}{3} - \frac{1}{4}x \right]_0^{1/2} \\ &= 2 \left[-\frac{1}{8 \cdot 3} - \frac{1}{8} - \left(-\frac{1}{3} - 0 \right) \right] = \frac{8}{24} = \frac{1}{3} \text{ sq unit} \end{aligned}$$

29. As from the figure, area enclosed between the curves is *OABCO*.

Thus, the point of intersection of $y = ax^2$ and $x = ay^2$

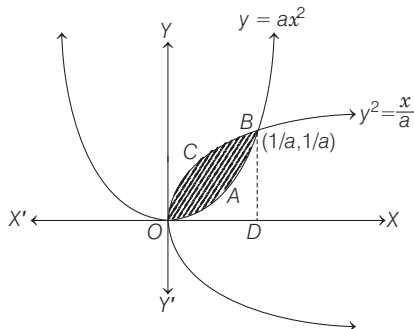

$$\begin{aligned} \Rightarrow x &= a(ax^2)^2 \\ \Rightarrow x &= 0, \frac{1}{a} \Rightarrow y = 0, \frac{1}{a} \end{aligned}$$

So, the points of intersection are $(0, 0)$ and $\left(\frac{1}{a}, \frac{1}{a}\right)$.

\therefore Required area *OABCO* = Area of curve *OCBDO* - Area of curve *OABDO*

$$\Rightarrow \int_0^{1/a} \left(\sqrt{\frac{x}{a}} - ax^2 \right) dx = 1 \quad [\text{given}]$$

$$\Rightarrow \left[\frac{1}{\sqrt{a}} \cdot \frac{x^{3/2}}{3/2} - \frac{ax^3}{3} \right]_0^{1/a} = 1 \Rightarrow \frac{2}{3a^2} - \frac{1}{3a^2} = 1$$

$$\Rightarrow a^2 = \frac{1}{3} \Rightarrow a = \frac{1}{\sqrt{3}} \quad [\because a > 0]$$

30. Since, $\int_1^b f(x) dx = (b-1) \sin(3b+4)$

On differentiating both sides w.r.t. b , we get

$$f(b) = 3(b-1) \cdot \cos(3b+4) + \sin(3b+4)$$

$$\therefore f(x) = \sin(3x+4) + 3(x-1) \cos(3x+4)$$

31. Given, $\frac{dy}{dx} = 2x+1$

On integrating both sides

$$\int dy = \int (2x+1) dx$$

$$\Rightarrow y = x^2 + x + C \text{ which passes through } (1, 2)$$

$$\therefore 2 = 1 + 1 + C$$

$$\Rightarrow C = 0$$

$$\therefore y = x^2 + x$$

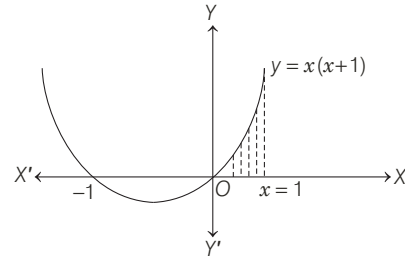

Thus, the required area bounded by X -axis, the curve and $x = 1$

$$= \int_0^1 (x^2 + x) dx = \left[\frac{x^3}{3} + \frac{x^2}{2} \right]_0^1 = \frac{1}{3} + \frac{1}{2} = \frac{5}{6} \text{ sq unit}$$

32. $\int_0^1 (x - x^3) dx = 2 \int_0^\alpha (x - x^3) dx$

$$\frac{1}{4} = 2 \left(\frac{\alpha^2}{2} - \frac{\alpha^4}{4} \right)$$

$$2\alpha^4 - 4\alpha^2 + 1 = 0$$

$$\Rightarrow \alpha^2 = \frac{4 - \sqrt{16-8}}{4} \quad (\because \alpha \in (0, 1))$$

$$\alpha^2 = 1 - \frac{1}{\sqrt{2}}$$

33. PLAN (i) Area of region $f(x)$ bounded between $x = a$ to $x = b$ is

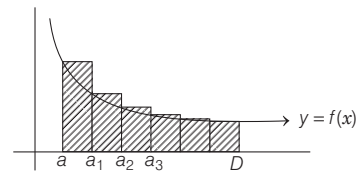

$$\int_a^b f(x) dx = \text{Sum of areas of rectangle shown in shaded part.}$$

(ii) If $f(x) \geq g(x)$ when defined in $[a, b]$, then

$$\int_a^b f(x) dx \geq \int_a^b g(x) dx$$

Description of Situation As the given curve $y=e^{-x^2}$ cannot be integrated, thus we have to bound this function by using above mentioned concept.

Graph for $y=e^{-x^2}$

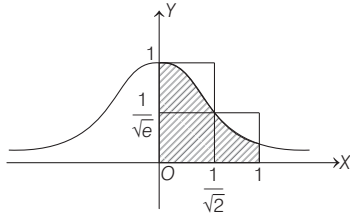

Since, $x^2 \leq x$ when $x \in [0, 1]$

$$\Rightarrow -x^2 \geq -x \text{ or } e^{-x^2} \geq e^{-x}$$

$$\therefore \int_0^1 e^{-x^2} dx \geq \int_0^1 e^{-x} dx$$

$$\Rightarrow S \geq -(e^{-x})_0^1 = 1 - \frac{1}{e} \quad \dots(i)$$

Also, $\int_0^1 e^{-x^2} dx \leq$ Area of two rectangles

$$\begin{aligned} &\leq \left(1 \times \frac{1}{\sqrt{2}}\right) + \left(1 - \frac{1}{\sqrt{2}}\right) \times \frac{1}{\sqrt{e}} \\ &\leq \frac{1}{\sqrt{2}} + \frac{1}{\sqrt{e}} \left(1 - \frac{1}{\sqrt{2}}\right) \quad \dots(ii) \end{aligned}$$

$$\therefore \frac{1}{\sqrt{2}} + \frac{1}{\sqrt{e}} \left(1 - \frac{1}{\sqrt{2}}\right) \geq S \geq 1 - \frac{1}{e} \quad [\text{from Eqs. (i) and (ii)}]$$

34. Shaded area = $e - \left(\int_0^1 e^x dx\right) = 1$

Also, $\int_1^e \ln(e+1-y) dy$ [put $e+1-y=t \Rightarrow -dy=dt$]

$$= \int_e^1 \ln t (-dt) = \int_1^e \ln t dt = \int_1^e \ln y dy = 1$$

35. **Case I** When $m = 0$

In this case, $y = x - x^2 \quad \dots(i)$

and $y = 0 \quad \dots(ii)$

are two given curves, $y > 0$ is total region above X -axis.

Therefore, area between $y = x - x^2$ and $y = 0$

is area between $y = x - x^2$ and above the X -axis

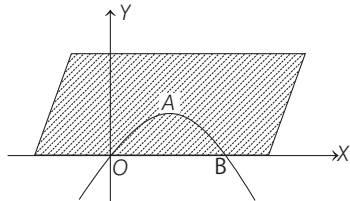

$$\therefore A = \int_0^1 (x - x^2) dx = \left[\frac{x^2}{2} - \frac{x^3}{3} \right]_0^1 = \frac{1}{2} - \frac{1}{3} = \frac{1}{6} \neq \frac{9}{2}$$

Hence, no solution exists.

Case II When $m < 0$

In this case, area between $y = x - x^2$ and $y = mx$ is

$OABCO$ and points of intersection are $(0,0)$ and $\{1-m, m(1-m)\}$.

$$\therefore \text{Area of curve } OABCO = \int_0^{1-m} [x - x^2 - mx] dx$$

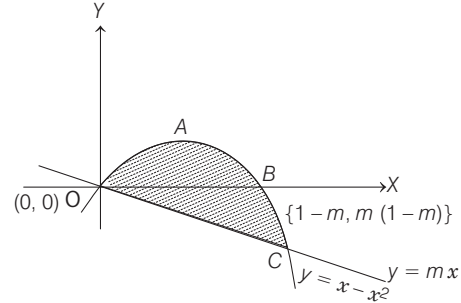

$$\begin{aligned} &= \left[(1-m) \frac{x^2}{2} - \frac{x^3}{3} \right]_0^{1-m} \\ &= \frac{1}{2} (1-m)^3 - \frac{1}{3} (1-m)^3 = \frac{1}{6} (1-m)^3 \end{aligned}$$

$$\therefore \frac{1}{6} (1-m)^3 = \frac{9}{2} \quad [\text{given}]$$

$$\Rightarrow (1-m)^3 = 27$$

$$\Rightarrow 1-m = 3$$

$$\Rightarrow m = -2$$

Case III When $m > 0$

In this case, $y = mx$ and $y = x - x^2$ intersect in $(0,0)$ and $\{(1-m), m(1-m)\}$ as shown in figure

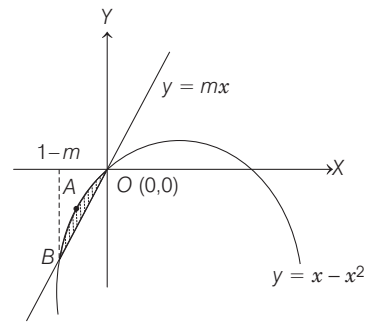

$$\therefore \text{Area of shaded region} = \int_{1-m}^0 (x - x^2 - mx) dx$$

$$\begin{aligned} &= \left[(1-m) \frac{x^2}{2} - \frac{x^3}{3} \right]_{1-m}^0 \\ &= -\frac{1}{2} (1-m) (1-m)^2 + \frac{1}{3} (1-m)^3 \\ &= -\frac{1}{6} (1-m)^3 \end{aligned}$$

$$\Rightarrow \frac{9}{2} = -\frac{1}{6} (1-m)^3 \quad [\text{given}]$$

$$\Rightarrow (1-m)^3 = -27$$

$$\Rightarrow (1-m) = -3$$

$$\Rightarrow m = 3 + 1 = 4$$

Therefore, (b) and (d) are the answers.

36. Given,
$$\begin{bmatrix} 4a^2 & 4a & 1 \\ 4b^2 & 4b & 1 \\ 4c^2 & 4c & 1 \end{bmatrix} \begin{bmatrix} f(-1) \\ f(1) \\ f(2) \end{bmatrix} = \begin{bmatrix} 3a^2 + 3a \\ 3b^2 + 3b \\ 3c^2 + 3c \end{bmatrix}$$

$\Rightarrow 4a^2 f(-1) + 4a f(1) + f(2) = 3a^2 + 3a, \dots(i)$

$4b^2 f(-1) + 4b f(1) + f(2) = 3b^2 + 3b \dots(ii)$

and $4c^2 f(-1) + 4c f(1) + f(2) = 3c^2 + 3c \dots(iii)$

where, $f(x)$ is quadratic expression given by,

$f(x) = ax^2 + bx + c$ and Eqs. (i), (ii) and (iii).

$\Rightarrow 4x^2 f(-1) + 4x f(1) + f(2) = 3x^2 + 3x$

or $\{4 f(-1) - 3\} x^2 + \{4f(1) - 3\} x + f(2) = 0 \dots(iv)$

As above equation has 3 roots a, b and c .

So, above equation is identity in x .

i.e. coefficients must be zero.

$\Rightarrow f(-1) = 3/4, f(1) = 3/4, f(2) = 0 \dots(v)$

$\therefore f(x) = ax^2 + bx + c$

$\therefore a = -1/4, b = 0$ and $c = 1$, using Eq. (v)

Thus, $f(x) = \frac{4-x^2}{4}$ shown as,

Let $A(-2, 0), B(2t, -t^2 + 1)$

Since, AB subtends right angle at vertex $V(0, 1)$.

$\Rightarrow \frac{1}{2} \cdot \frac{-t^2}{2t} = -1 \Rightarrow t = 4$

$\therefore B(8, -15)$

So, equation of chord AB is $y = \frac{-(3x+6)}{2}$.

\therefore Required area = $\left| \int_{-2}^8 \left(\frac{4-x^2}{4} + \frac{3x+6}{2} \right) dx \right|$
 $= \left| \left(x - \frac{x^3}{12} + \frac{3x^2}{4} + 3x \right)_{-2}^8 \right|$
 $= \left| \left[8 - \frac{128}{3} + 48 + 24 - \left(-2 + \frac{2}{3} + 3 - 6 \right) \right] \right|$
 $= \frac{125}{3}$ sq units

37. The region bounded by the curves $y = x^2, y = -x^2$ and $y^2 = 4x - 3$ is symmetrical about X -axis, where $y = 4x - 3$ meets at $(1, 1)$.

\therefore Area of curve $(OABCO)$

$= 2 \left[\int_0^1 x^2 dx - \int_{3/4}^1 (\sqrt{4x-3}) dx \right]$

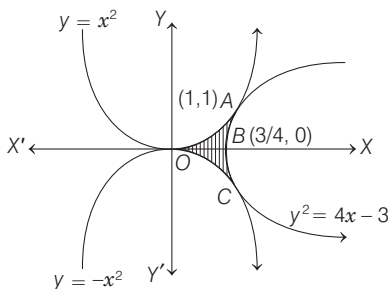

$= 2 \left[\left(\frac{x^3}{3} \right)_0^1 - \left(\frac{(4x-3)^{3/2}}{3 \cdot 4/2} \right)_{3/4}^1 \right]$
 $= 2 \left(\frac{1}{3} - \frac{1}{6} \right) = 1 \cdot \frac{1}{6} = \frac{1}{3}$ sq unit

38. Here, slope of tangent,

$\frac{dy}{dx} = \frac{(x+1)^2 + y - 3}{(x+1)} \Rightarrow \frac{dy}{dx} = (x+1) + \frac{(y-3)}{(x+1)}$

Put $x+1 = X$ and $y-3 = Y$

$\Rightarrow \frac{dy}{dx} = \frac{dY}{dX}$

$\therefore \frac{dY}{dX} = X + \frac{Y}{X}$

$\Rightarrow \frac{dY}{dX} - \frac{1}{X} Y = X$

IF = $e^{\int -\frac{1}{X} dX} = e^{-\log X} = \frac{1}{X}$

\therefore Solution is, $Y \cdot \frac{1}{X} = \int X \cdot \frac{1}{X} dX + c \Rightarrow \frac{Y}{X} = X + c$

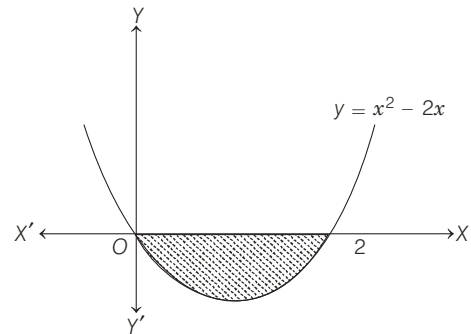

$y - 3 = (x + 1)^2 + c(x + 1)$, which passes through $(2, 0)$.
 $\Rightarrow -3 = (3)^2 + 3c \Rightarrow c = -4$

\therefore Required curve

$y = (x + 1)^2 - 4(x + 1) + 3 \Rightarrow y = x^2 - 2x$

\therefore Required area = $\left| \int_0^2 (x^2 - 2x) dx \right| = \left| \left(\frac{x^3}{3} - x^2 \right)_0^2 \right|$

$= \frac{8}{3} - 4 = \frac{4}{3}$ sq units

39. The points in the graph are

$A(1, 1), B(\sqrt{2}, 0), C(2, 2), D(\sqrt{2}, 2)$

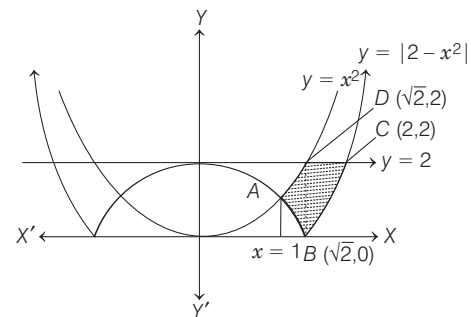

∴ Required area

$$\begin{aligned} &= \int_1^{\sqrt{2}} \{x^2 - (2 - x^2)\} dx + \int_{\sqrt{2}}^2 \{2 - (x^2 - 2)\} dx \\ &= \int_1^{\sqrt{2}} (2x^2 - 2) dx + \int_{\sqrt{2}}^2 (4 - x^2) dx \\ &= \left[\frac{2x^3}{3} - 2x \right]_1^{\sqrt{2}} + \left[4x - \frac{x^3}{3} \right]_{\sqrt{2}}^2 \\ &= \left[\frac{4\sqrt{2}}{3} - 2\sqrt{2} - \frac{2}{3} + 2 \right] + \left[8 - \frac{8}{3} - 4\sqrt{2} + \frac{2\sqrt{2}}{3} \right] \\ &= \left(\frac{20 - 12\sqrt{2}}{3} \right) \text{ sq units} \end{aligned}$$

40. Given, $x = (\sin by) e^{-ay}$

Now, $-1 \leq \sin by \leq 1$
 $\Rightarrow -e^{-ay} \leq e^{-ay} \sin by \leq e^{-ay} \Rightarrow -e^{-ay} \leq x \leq e^{-ay}$

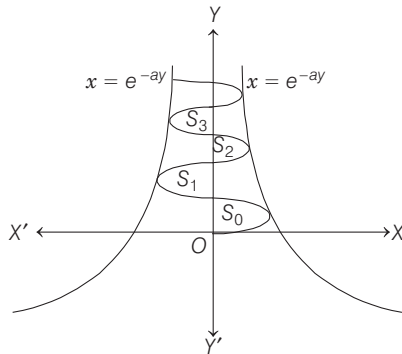

In this case, if we take a and b positive, the values $-e^{-ay}$ and e^{-ay} become left bond and right bond of the curve and due to oscillating nature of $\sin by$, it will oscillate between $x = e^{-ay}$ and $x = -e^{-ay}$

Now, $S_j = \int_{j\pi/b}^{(j+1)\pi/b} \sin by \cdot e^{-ay} dy$

$$\left[\begin{array}{l} \text{since, } I = \int \sin by \cdot e^{-ay} dy \\ I = \frac{-e^{-ay}}{a^2 + b^2} (a \sin by + b \cos by) \end{array} \right]$$

$$\begin{aligned} \therefore S_j &= \left| \frac{-1}{a^2 + b^2} \left[e^{-\frac{a(j+1)\pi}{b}} \{a \sin(j+1)\pi + b \cos(j+1)\pi\} \right. \right. \\ &\quad \left. \left. - e^{-\frac{aj\pi}{b}} (a \sin j\pi + b \cos j\pi) \right] \right| \\ S_j &= \left| -\frac{1}{a^2 + b^2} \left[e^{-\frac{a(j+1)\pi}{b}} \{0 + b(-1)^{j+1}\} \right. \right. \\ &\quad \left. \left. - e^{-aj\pi/b} \{0 + b(-1)^j\} \right] \right| \\ &= \left| \frac{b(-1)^j e^{-\frac{aj\pi}{b}}}{a^2 + b^2} \left(e^{-\frac{a}{b}\pi} + 1 \right) \right| \\ &= \frac{b e^{-\frac{aj\pi}{b}}}{a^2 + b^2} \left(e^{-\frac{a}{b}\pi} + 1 \right) \end{aligned}$$

[∵ $(-1)^{j+2} = (-1)^2 (-1)^j = (-1)^j$]

$$\begin{aligned} \therefore \frac{S_j}{S_{j-1}} &= \frac{\frac{b e^{-\frac{aj\pi}{b}} \left(e^{-\frac{a\pi}{b}} + 1 \right)}{a^2 + b^2}}{\frac{b e^{-\frac{a(j-1)\pi}{b}} \left(e^{-\frac{a\pi}{b}} + 1 \right)}{a^2 + b^2}} = \frac{e^{-\frac{a}{b}\pi}}{e^{-\frac{a}{b}(j-1)\pi}} \\ &= e^{-\frac{a}{b}\pi} = \text{constant} \end{aligned}$$

∴ $S_0, S_1, S_2, \dots, S_j$ form a GP.

For $a = -1$ and $b = \pi$

$$\begin{aligned} S_j &= \frac{\pi \cdot e^{\frac{1}{\pi}j}}{(1 + \pi^2)} \left(e^{\frac{1}{\pi}} + 1 \right) = \frac{\pi \cdot e^j}{(1 + \pi^2)} (1 + e) \\ \Rightarrow \sum_{j=0}^n S_j &= \frac{\pi \cdot (1 + e)}{(1 + \pi^2)^2} \sum_{j=0}^n e^j = \frac{\pi(1 + e)}{(1 + \pi^2)} (e^0 + e^1 + \dots + e^n) \\ &= \frac{\pi(1 + e)}{(1 + \pi^2)} \cdot \frac{(e^{n+1} - 1)}{e - 1} \end{aligned}$$

41. Given, $f(x) = \begin{cases} 2x, & |x| \leq 1 \\ x^2 + ax + b, & |x| > 1 \end{cases}$

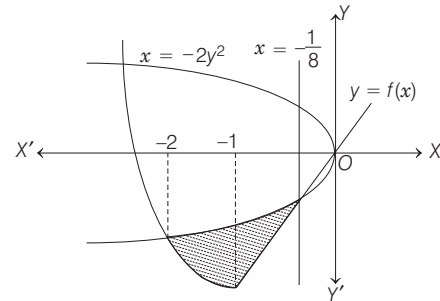

$$\Rightarrow f(x) = \begin{cases} x^2 + ax + b, & \text{if } x < -1 \\ 2x, & \text{if } -1 \leq x < 1 \\ x^2 + ax + b, & \text{if } x \geq 1 \end{cases}$$

f is continuous on R , so f is continuous at -1 and 1 .

$$\begin{aligned} \lim_{x \rightarrow -1^-} f(x) &= \lim_{x \rightarrow -1^+} f(x) = f(-1) \\ \text{and } \lim_{x \rightarrow 1^-} f(x) &= \lim_{x \rightarrow 1^+} f(x) = f(1) \\ \Rightarrow 1 - a + b &= -2 \text{ and } 2 = 1 + a + b \\ \Rightarrow a - b &= 3 \text{ and } a + b = 1 \\ \therefore a &= 2, \quad b = -1 \end{aligned}$$

$$\text{Hence, } f(x) = \begin{cases} x^2 + 2x - 1, & \text{if } x < -1 \\ 2x, & \text{if } -1 \leq x < 1 \\ x^2 + 2x - 1, & \text{if } x \geq 1 \end{cases}$$

Next, we have to find the points $x = -2y^2$ and $y = f(x)$. The point of intersection is $(-2, -1)$.

$$\begin{aligned} \therefore \text{Required area} &= \int_{-2}^{-1/8} \left[\sqrt{\frac{-x}{2}} - f(x) \right] dx \\ &= \int_{-2}^{-1/8} \sqrt{\frac{-x}{2}} dx - \int_{-2}^{-1} (x^2 + 2x - 1) dx - \int_{-1}^{-1/8} 2x dx \end{aligned}$$

$$\begin{aligned}
 &= -\frac{2}{3\sqrt{2}} [(-x)^{3/2}]_{-2}^{-1/8} - \left[\left(\frac{x^3}{3} + x^2 - x \right) \right]_{-2}^{-1} - [x^2]_{-1}^{-1/8} \\
 &= -\frac{2}{3\sqrt{2}} \left[\left(\frac{1}{8} \right)^{3/2} - 2^{3/2} \right] - \left(-\frac{1}{3} + 1 + 1 \right) \\
 &\quad + \left(-\frac{8}{3} + 4 + 2 \right) - \left[\frac{1}{64} - 1 \right] \\
 &= \frac{\sqrt{2}}{3} [2\sqrt{2} - 2^{-9/2}] + \frac{5}{3} + \frac{63}{64} \\
 &= \frac{63}{16 \times 3} + \frac{509}{64 \times 3} = \frac{761}{192} \text{ sq units}
 \end{aligned}$$

42. Refer to the figure given in the question. Let the coordinates of P be (x, x^2) , where $0 \leq x \leq 1$.

For the area ($OPRO$),

Upper boundary: $y = x^2$ and

lower boundary : $y = f(x)$

Lower limit of x : 0

Upper limit of x : x

$$\begin{aligned}
 \therefore \text{Area } (OPRO) &= \int_0^x t^2 dt - \int_0^x f(t) dt \\
 &= \left[\frac{t^3}{3} \right]_0^x - \int_0^x f(t) dt \\
 &= \frac{x^3}{3} - \int_0^x f(t) dt
 \end{aligned}$$

For the area ($OPQO$),

The upper curve : $x = \sqrt{y}$

and the lower curve : $x = y/2$

Lower limit of y : 0

and upper limit of y : x^2

$$\begin{aligned}
 \therefore \text{Area } (OPQO) &= \int_0^{x^2} \sqrt{t} dt - \int_0^{x^2} \frac{t}{2} dt \\
 &= \frac{2}{3} [t^{3/2}]_0^{x^2} - \frac{1}{4} [t^2]_0^{x^2} = \frac{2}{3} x^3 - \frac{x^4}{4}
 \end{aligned}$$

According to the given condition,

$$\frac{x^3}{3} - \int_0^x f(t) dt = \frac{2}{3} x^3 - \frac{x^4}{4}$$

On differentiating both sides w.r.t. x , we get

$$x^2 - f(x) \cdot 1 = 2x^2 - x^3$$

$$\Rightarrow f(x) = x^3 - x^2, 0 \leq x \leq 1$$

43. We can draw the graph of $y = x^2$, $y = (1 - x^2)$ and $y = 2x(1 - x)$ in following figure

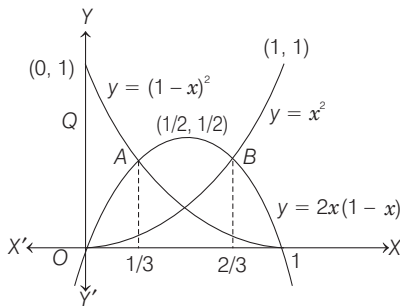

Now, to get the point of intersection of $y = x^2$ and $y = 2x(1 - x)$, we get

$$\begin{aligned}
 x^2 &= 2x(1 - x) \\
 \Rightarrow 3x^2 &= 2x \\
 \Rightarrow x(3x - 2) &= 0 \\
 \Rightarrow x &= 0, 2/3
 \end{aligned}$$

Similarly, we can find the coordinate of the points of intersection of

$$y = (1 - x^2) \text{ and } y = 2x(1 - x) \text{ are } x = 1/3 \text{ and } x = 1$$

From the figure, it is clear that,

$$f(x) = \begin{cases} (1 - x)^2, & \text{if } 0 \leq x \leq 1/3 \\ 2x(1 - x), & \text{if } 1/3 \leq x \leq 2/3 \\ x^2, & \text{if } 2/3 \leq x \leq 1 \end{cases}$$

\therefore The required area

$$\begin{aligned}
 A &= \int_0^1 f(x) dx \\
 &= \int_0^{1/3} (1 - x)^2 dx + \int_{1/3}^{2/3} 2x(1 - x) dx + \int_{2/3}^1 x^2 dx \\
 &= \left[-\frac{1}{3}(1 - x)^3 \right]_0^{1/3} + \left[x^2 - \frac{2x^3}{3} \right]_{1/3}^{2/3} + \left[\frac{1}{3}x^3 \right]_{2/3}^1 \\
 &= \left[-\frac{1}{3} \left(\frac{2}{3} \right)^3 + \frac{1}{3} \right] + \left[\left(\frac{2}{3} \right)^2 - \frac{2}{3} \left(\frac{2}{3} \right)^3 - \left(\frac{1}{3} \right)^2 + \frac{2}{3} \left(\frac{1}{3} \right)^3 \right] \\
 &\quad + \left[\frac{1}{3}(1) - \frac{1}{3} \left(\frac{2}{3} \right)^3 \right] \\
 &= \frac{19}{81} + \frac{13}{81} + \frac{19}{81} = \frac{17}{27} \text{ sq unit}
 \end{aligned}$$

44. Eliminating y from $y = \frac{x^2}{b}$ and $y = x - bx^2$, we get

$$\begin{aligned}
 x^2 &= bx - b^2x^2 \\
 \Rightarrow x &= 0, \frac{b}{1 + b^2}
 \end{aligned}$$

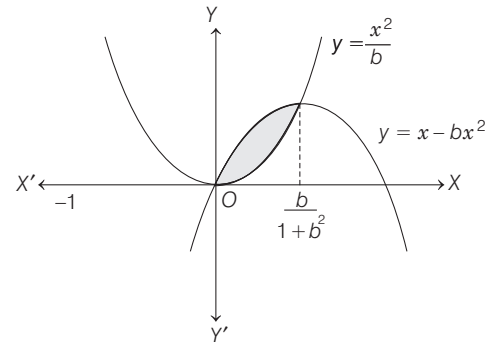

Thus, the area enclosed between the parabolas

$$\begin{aligned}
 A &= \int_0^{b/(1+b^2)} \left(x - bx^2 - \frac{x^2}{b} \right) dx \\
 &= \left[\frac{x^2}{2} - \frac{x^3}{3} \cdot \frac{1+b^2}{b} \right]_0^{b/(1+b^2)} = \frac{1}{6} \cdot \frac{b^2}{(1+b^2)^2}
 \end{aligned}$$

On differentiating w.r.t. b , we get

$$\begin{aligned} \frac{dA}{db} &= \frac{1}{6} \cdot \frac{(1+b^2)^2 \cdot 2b - 2b^2 \cdot (1+b^2) \cdot 2b}{(1+b^2)^4} \\ &= \frac{1}{3} \cdot \frac{b(1-b^2)}{(1+b^2)^3} \end{aligned}$$

For maximum value of A , put $\frac{dA}{db} = 0$

$$\Rightarrow b = -1, 0, 1, \text{ since } b > 0$$

\therefore We consider only $b = 1$.

Sign scheme for $\frac{dA}{db}$ around $b = 1$ is as shown below :

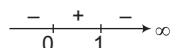

From sign scheme, it is clear that A is maximum at $b = 1$.

45. We have, $A_n = \int_0^{\pi/4} (\tan x)^n dx$

Since, $0 < \tan x < 1$, when $0 < x < \pi/4$

We have, $0 < (\tan x)^{n+1} < (\tan x)^n$ for each $n \in \mathbb{N}$

$$\Rightarrow \int_0^{\pi/4} (\tan x)^{n+1} dx < \int_0^{\pi/4} (\tan x)^n dx$$

$$\Rightarrow A_{n+1} < A_n$$

Now, for $n > 2$

$$\begin{aligned} A_n + A_{n+2} &= \int_0^{\pi/4} [(\tan x)^n + (\tan x)^{n+2}] dx \\ &= \int_0^{\pi/4} (\tan x)^n (1 + \tan^2 x) dx \end{aligned}$$

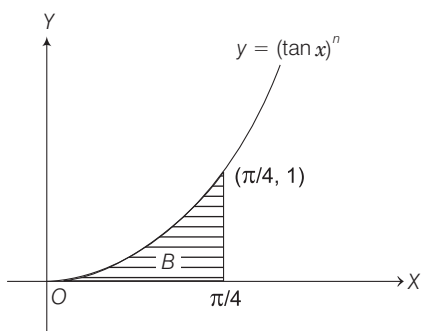

$$\begin{aligned} &= \int_0^{\pi/4} (\tan x)^n \sec^2 x dx \\ &= \left[\frac{1}{(n+1)} (\tan x)^{n+1} \right]_0^{\pi/4} \\ &= \frac{1}{(n+1)} (1 - 0) = \frac{1}{n+1} \end{aligned}$$

Since, then

$$A_{n+2} < A_{n+1} < A_n, \quad A_n + A_{n+2} < 2A_n$$

$$\Rightarrow \frac{1}{n+1} < 2A_n$$

$$\Rightarrow \frac{1}{2n+2} < A_n \quad \dots(i)$$

Also, for $n > 2$ $A_n + A_n < A_n + A_{n-2} = \frac{1}{n-1}$

$$\Rightarrow 2A_n < \frac{1}{n-1}$$

$$\Rightarrow A_n < \frac{1}{2n-2} \quad \dots(ii)$$

From Eqs. (i) and (ii), $\frac{1}{2n+2} < A_n < \frac{1}{2n-2}$

46. The equations of the sides of the square are as follow :

$$AB: y = 1, BC: x = -1, CD: y = -1, DA: x = 1$$

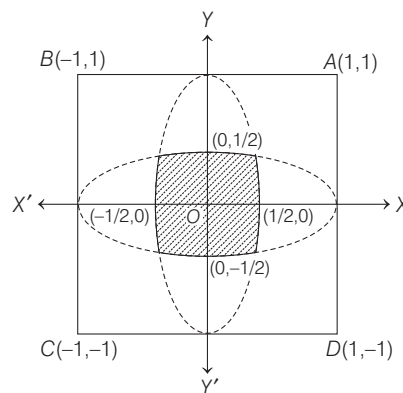

Let the region be S and (x, y) is any point inside it.

Then, according to given conditions,

$$\begin{aligned} \sqrt{x^2 + y^2} &< |1-x|, |1+x|, |1-y|, |1+y| \\ \Rightarrow x^2 + y^2 &< (1-x)^2, (1+x)^2, (1-y)^2, (1+y)^2 \\ \Rightarrow x^2 + y^2 &< x^2 - 2x + 1, x^2 + 2x + 1, \\ &\quad y^2 - 2y + 1, y^2 + 2y + 1 \\ \Rightarrow y^2 &< 1 - 2x, y^2 < 1 + 2x, x^2 < 1 - 2y \text{ and } x^2 < 2y + 1 \end{aligned}$$

Now, in $y^2 = 1 - 2x$ and $y^2 = 1 + 2x$, the first equation represents a parabola with vertex at $(1/2, 0)$ and second equation represents a parabola with vertex $(-1/2, 0)$ and in $x^2 = 1 - 2y$ and $x^2 = 1 + 2y$, the first equation represents a parabola with vertex at $(0, 1/2)$ and second equation represents a parabola with vertex at $(0, -1/2)$.

Therefore, the region S is lying inside the four parabolas

$$y^2 = 1 - 2x, y^2 = 1 + 2x, x^2 = 1 + 2y, x^2 = 1 - 2y$$

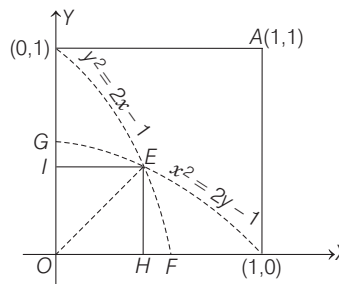

where, S is the shaded region.

Now, S is symmetrical in all four quadrants, therefore $S = 4 \times$ Area lying in the first quadrant.

Now, $y^2 = 1 - 2x$ and $x^2 = 1 - 2y$ intersect on the line $y = x$. The point of intersection is $E(\sqrt{2}-1, \sqrt{2}-1)$.

Area of the region $OEFO$

$$= \text{Area of } \triangle OEH + \text{Area of } HEFH$$

$$\begin{aligned}
 &= \frac{1}{2} (\sqrt{2} - 1)^2 + \int_{\sqrt{2}-1}^{1/2} \sqrt{1-2x} \, dx \\
 &= \frac{1}{2} (\sqrt{2} - 1)^2 + \left[(1-2x)^{3/2} \cdot \frac{2}{3} \cdot \frac{1}{2} (-1) \right]_{\sqrt{2}-1}^{1/2} \\
 &= \frac{1}{2} (2 + 1 - 2\sqrt{2}) + \frac{1}{3} (1 + 2 - 2\sqrt{2})^{3/2} \\
 &= \frac{1}{2} (3 - 2\sqrt{2}) + \frac{1}{3} (3 - 2\sqrt{2})^{3/2} \\
 &= \frac{1}{2} (3 - 2\sqrt{2}) + \frac{1}{3} [(\sqrt{2} - 1)^2]^{3/2} \\
 &= \frac{1}{2} (3 - 2\sqrt{2}) + \frac{1}{3} (\sqrt{2} - 1)^3 \\
 &= \frac{1}{2} (3 - \sqrt{2}) + \frac{1}{3} [2\sqrt{2} - 1 - 3\sqrt{2} (\sqrt{2} - 1)] \\
 &= \frac{1}{2} (3 - 2\sqrt{2}) + \frac{1}{3} [5\sqrt{2} - 7] \\
 &= \frac{1}{6} [9 - 6\sqrt{2} + 10\sqrt{2} - 14] = \frac{1}{6} [4\sqrt{2} - 5] \text{ sq units}
 \end{aligned}$$

Similarly, area $OEGO = \frac{1}{6} (4\sqrt{2} - 5)$ sq units

Therefore, area of S lying in first quadrant
 $= \frac{2}{6} (4\sqrt{2} - 5) = \frac{1}{3} (4\sqrt{2} - 5)$ sq units

Hence, $S = \frac{4}{3} (4\sqrt{2} - 5) = \frac{1}{3} (16\sqrt{2} - 20)$ sq units

47. Given parabolas are $y = 4x - x^2$
 and $y = -(x-2)^2 + 4$ or $(x-2)^2 = -(y-4)$
 Therefore, it is a vertically downward parabola with
 vertex at $(2,4)$ and its axis is $x = 2$

and $y = x^2 - x \Rightarrow y = \left(x - \frac{1}{2}\right)^2 - \frac{1}{4}$



$$\Rightarrow \left(x - \frac{1}{2}\right)^2 = y + \frac{1}{4}$$

This is a parabola having its vertex at $\left(\frac{1}{2}, -\frac{1}{4}\right)$.

Its axis is at $x = \frac{1}{2}$ and opening upwards.

The points of intersection of given curves are

$$\begin{aligned}
 4x - x^2 &= x^2 - x \Rightarrow 2x^2 = 5x \\
 \Rightarrow x(2 - 5x) &= 0 \Rightarrow x = 0, \frac{5}{2}
 \end{aligned}$$

Also, $y = x^2 - x$ meets X -axis at $(0,0)$ and $(1, 0)$.

$$\begin{aligned}
 \therefore \text{Area, } A_1 &= \int_0^{5/2} [(4x - x^2) - (x^2 - x)] \, dx \\
 &= \int_0^{5/2} (5x - 2x^2) \, dx \\
 &= \left[\frac{5}{2} x^2 - \frac{2}{3} x^3 \right]_0^{5/2} = \frac{5}{2} \left(\frac{5}{2}\right)^2 - \frac{2}{3} \left(\frac{5}{2}\right)^3 \\
 &= \frac{5}{2} \cdot \frac{25}{4} - \frac{2}{3} \cdot \frac{125}{8} \\
 &= \frac{125}{8} \left(1 - \frac{2}{3}\right) = \frac{125}{24} \text{ sq units}
 \end{aligned}$$

This area is considering above and below X -axis both. Now, for area below X -axis separately, we consider

$$A_2 = - \int_0^1 (x^2 - x) \, dx = \left[\frac{x^2}{2} - \frac{x^3}{3} \right]_0^1 = \frac{1}{2} - \frac{1}{3} = \frac{1}{6} \text{ sq units}$$

Therefore, net area above the X -axis is

$$A_1 - A_2 = \frac{125 - 4}{24} = \frac{121}{24} \text{ sq units}$$

Hence, ratio of area above the X -axis and area below X -axis

$$= \frac{121}{24} : \frac{1}{6} = 121 : 4$$

48. The curve $y = x^2$ is a parabola. It is symmetric about Y -axis and has its vertex at $(0, 0)$ and the curve $y = \frac{2}{1+x^2}$ is a bell shaped curve. X -axis is its asymptote and it is symmetric about Y -axis and its vertex is $(0, 2)$.

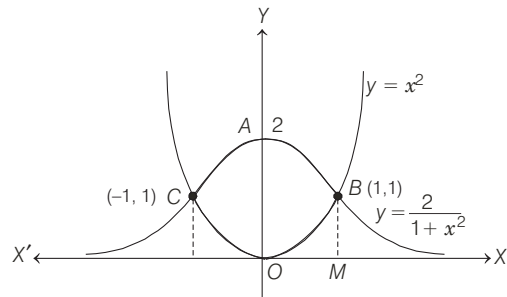

Since, $y = x^2$... (i)

and $y = \frac{2}{1+x^2}$... (ii)

$$\Rightarrow y = \frac{2}{1+y} \Rightarrow y^2 + y - 2 = 0$$

$$\Rightarrow (y-1)(y+2) = 0 \Rightarrow y = -2, 1$$

But $y \geq 0$, so $y = 1 \Rightarrow x = \pm 1$

Therefore, coordinates of C are $(-1, 1)$ and coordinates of B are $(1, 1)$.

\therefore Required area $OBACO = 2 \times$ Area of curve $OBAO$

$$\begin{aligned}
 &= 2 \left[\int_0^1 \frac{2}{1+x^2} \, dx - \int_0^1 x^2 \, dx \right] \\
 &= 2 \left[2 \tan^{-1} x \Big|_0^1 - \left[\frac{x^3}{3} \right]_0^1 \right] = 2 \left[\frac{2\pi}{4} - \frac{1}{3} \right] = \left(\pi - \frac{2}{3} \right) \text{ sq unit}
 \end{aligned}$$

49. The required area is the shaded portion in following figure

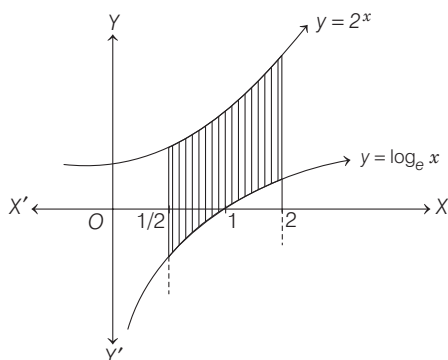

∴ The required area

$$= \int_{1/2}^2 (2^x - \log x) dx = \left(\frac{2^x}{\log 2} - (x \log x - x) \right) \Big|_{1/2}^2$$

$$= \left(\frac{4 - \sqrt{2}}{\log 2} - \frac{5}{2} \log 2 + \frac{3}{2} \right) \text{sq units}$$

50. Both the curves are defined for $x > 0$.
Both are positive when $x > 1$ and negative when $0 < x < 1$.
We know that, $\lim_{x \rightarrow 0^+} (\log x) \rightarrow -\infty$

Hence, $\lim_{x \rightarrow 0^+} \frac{\log x}{ex} \rightarrow -\infty$. Thus, Y -axis is asymptote of second curve.

And $\lim_{x \rightarrow 0^+} ex \log x$ [[$(0) \times \infty$ form]]

$$= \lim_{x \rightarrow 0^+} \frac{e \log x}{1/x}$$

[[$-\infty / \infty$ form]]

$$= \lim_{x \rightarrow 0^+} \frac{e \left(\frac{1}{x} \right)}{\left(-\frac{1}{x^2} \right)} = 0$$

[using L'Hospital's rule]

Thus, the first curve starts from $(0, 0)$ but does not include $(0, 0)$.

Now, the given curves intersect, therefore

$$ex \log x = \frac{\log x}{ex}$$

i.e. $(e^2 x^2 - 1) \log x = 0$

$$\Rightarrow x = 1, \frac{1}{e} \quad [\because x > 0]$$

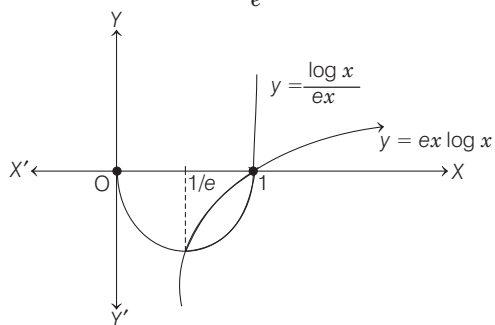

∴ The required area

$$= \int_{1/e}^1 \left(\frac{\log x}{ex} - ex \log x \right) dx$$

$$= \frac{1}{e} \left[\frac{(\log x)^2}{2} \right]_{1/e}^1 - e \left[\frac{x^2}{4} (2 \log x - 1) \right]_{1/e}^1 = \left(\frac{e^2 - 5}{4e} \right) \text{sq units}$$

51. Given, $y = x(x-1)^2 \Rightarrow \frac{dy}{dx} = x \cdot 2(x-1) + (x-1)^2$

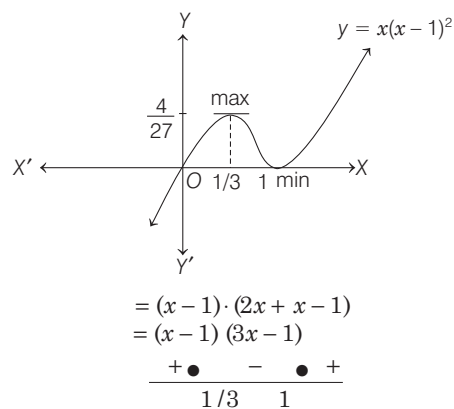

$$= (x-1) \cdot (2x+x-1)$$

$$= (x-1)(3x-1)$$

$$\begin{matrix} + & \bullet & - & \bullet & + \\ & 1/3 & & 1 & \end{matrix}$$

∴ Maximum at $x = 1/3$

$$y_{\max} = \frac{1}{3} \left(-\frac{2}{3} \right)^2 = \frac{4}{27}$$

Minimum at $x = 1$

$$y_{\min} = 0$$

Now, to find the area bounded by the curve $y = x(x-1)^2$, the Y -axis and line $x = 2$.

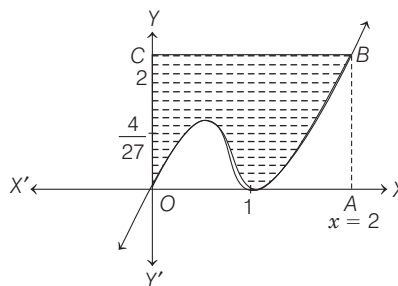

∴ Required area = Area of square $OABC - \int_0^2 y dx$

$$= 2 \times 2 - \int_0^2 x(x-1)^2 dx$$

$$= 4 - \left[\left[\frac{x(x-1)^3}{3} \right]_0^2 - \frac{1}{3} \int_0^2 (x-1)^3 \cdot 1 dx \right]$$

$$= 4 - \left[\frac{x}{3} (x-1)^3 - \frac{(x-1)^4}{12} \right]_0^2$$

$$= 4 - \left[\frac{2}{3} - \frac{1}{12} + \frac{1}{12} \right] = \frac{10}{3} \text{sq units}$$

52. Given, $y = \tan x \Rightarrow \frac{dy}{dx} = \sec^2 x$

∴ $\left(\frac{dy}{dx} \right)_{x=\pi/4} = 2$

352 Area

Hence, equation of tangent at $A\left(\frac{\pi}{4}, 1\right)$ is

$$\frac{y-1}{x-\pi/4} = 2$$

$$\Rightarrow y-1 = 2x - \frac{\pi}{2}$$

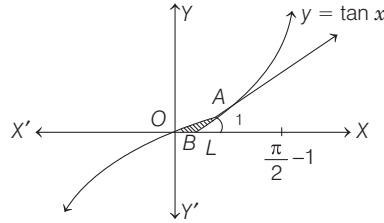

$$\Rightarrow (2x - y) = \left(\frac{\pi}{2} - 1\right)$$

∴ Required area is $OABO$

$$\begin{aligned} &= \int_0^{\pi/4} (\tan x) dx - \text{area of } \triangle ALB \\ &= [\log |\sec x|]_0^{\pi/4} - \frac{1}{2} \cdot BL \cdot AL \\ &= \log \sqrt{2} - \frac{1}{2} \left(\frac{\pi}{4} - \frac{\pi-2}{4}\right) \cdot 1 \\ &= \left(\log \sqrt{2} - \frac{1}{4}\right) \text{ sq unit} \end{aligned}$$

53. Given curves, $x^2 + y^2 = 25$, $4y = |4 - x^2|$ could be sketched as below, whose points of intersection are

$$x^2 + \frac{(4-x^2)^2}{16} = 25$$

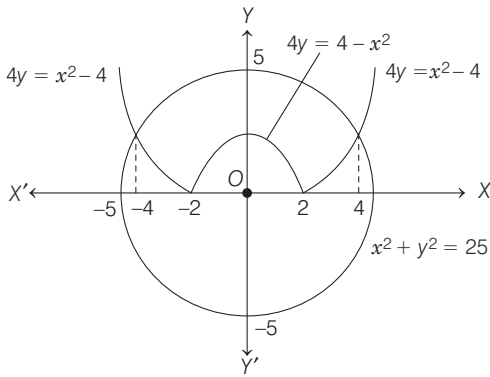

$$\Rightarrow (x^2 + 24)(x^2 - 16) = 0$$

$$\Rightarrow x = \pm 4$$

$$\begin{aligned} \therefore \text{Required area} &= 2 \left[\int_0^4 \sqrt{25-x^2} dx - \int_0^2 \left(\frac{4-x^2}{4}\right) dx \right. \\ &\quad \left. - \int_2^4 \left(\frac{x^2-4}{4}\right) dx \right] \\ &= 2 \left[\left[\frac{x}{2} \sqrt{25-x^2} + \frac{25}{2} \sin^{-1}\left(\frac{x}{5}\right) \right]_0^4 \right. \\ &\quad \left. - \frac{1}{4} \left[4x - \frac{x^3}{3} \right]_0^2 - \frac{1}{4} \left[\frac{x^3}{3} - 4x \right]_2^4 \right] \end{aligned}$$

$$\begin{aligned} &= 2 \left[\left[6 + \frac{25}{2} \sin^{-1}\left(\frac{4}{5}\right) \right] - \frac{1}{4} \left[8 - \frac{8}{3} \right] \right. \\ &\quad \left. - \frac{1}{4} \left[\left(\frac{64}{3} - 16\right) - \left(\frac{8}{3} - 8\right) \right] \right] \\ &= 2 \left[6 + \frac{25}{2} \sin^{-1}\left(\frac{4}{5}\right) - \frac{4}{3} - \frac{4}{3} - \frac{4}{3} \right] \\ &= \left[4 + 25 \sin^{-1}\left(\frac{4}{5}\right) \right] \text{ sq units} \end{aligned}$$

54. Given curves are $x^2 + y^2 = 4$, $x^2 = -\sqrt{2}y$ and $x = y$.

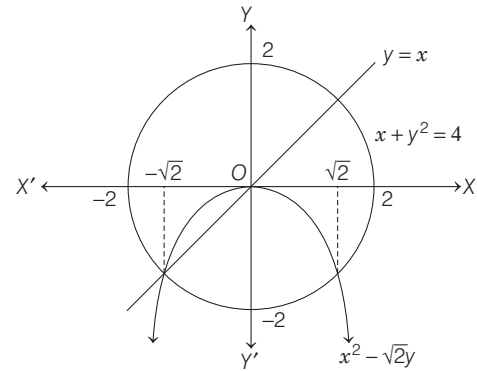

Thus, the required area

$$\begin{aligned} &= \left| \int_{-\sqrt{2}}^{\sqrt{2}} \sqrt{4-x^2} dx \right| - \left| \int_{-\sqrt{2}}^0 x dx \right| - \left| \int_0^{\sqrt{2}} \frac{-x^2}{\sqrt{2}} dx \right| \\ &= 2 \int_0^{\sqrt{2}} \sqrt{4-x^2} dx - \left| \left(\frac{x^2}{2}\right)_{-\sqrt{2}}^0 \right| - \left| \frac{x^3}{3\sqrt{2}} \right|_0^{\sqrt{2}} \\ &= 2 \left\{ \frac{x}{2} \sqrt{4-x^2} - \frac{4}{2} \sin^{-1} \frac{x}{2} \right\}_0^{\sqrt{2}} - 1 - \frac{2}{3} \\ &= (2 - \pi) - \frac{5}{3} = \left(\frac{1}{3} - \pi\right) \text{ sq units} \end{aligned}$$

55. Given curves $y = \sqrt{5-x^2}$ and $y = |x-1|$ could be sketched as shown, whose point of intersection are

$$5 - x^2 = (x-1)^2$$

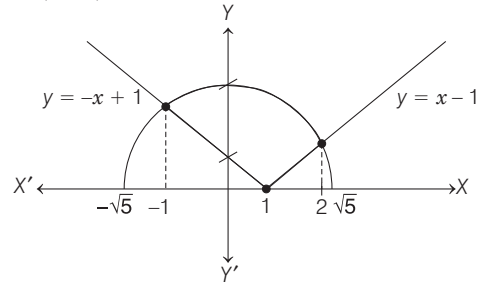

$$\Rightarrow 5 - x^2 = x^2 - 2x + 1 \Rightarrow 2x^2 - 2x - 4 = 0 \Rightarrow x = 2, -1$$

∴ Required area

$$\begin{aligned} &= \int_{-1}^2 \sqrt{5-x^2} dx - \int_{-1}^1 (-x+1) dx - \int_1^2 (x-1) dx \\ &= \left[\frac{x}{2} \sqrt{5-x^2} + \frac{5}{2} \sin^{-1}\left(\frac{x}{\sqrt{5}}\right) \right]_{-1}^2 - \left[\frac{-x^2}{2} + x \right]_{-1}^1 - \left[\frac{x^2}{2} - x \right]_1^2 \end{aligned}$$

$$\begin{aligned}
 &= \left(1 + \frac{5}{2} \sin^{-1} \frac{2}{\sqrt{5}}\right) - \left[-1 + \frac{5}{2} \sin^{-1} \left(\frac{-1}{\sqrt{5}}\right)\right] \\
 &\quad - \left(-\frac{1}{2} + 1 + \frac{1}{2} + 1\right) - \left(2 - 2 - \frac{1}{2} + 1\right) \\
 &= \frac{5}{2} \left(\sin^{-1} \frac{2}{\sqrt{5}} + \sin^{-1} \frac{1}{\sqrt{5}}\right) - \frac{1}{2} \\
 &= \frac{5}{2} \sin^{-1} \left(\frac{2}{\sqrt{5}} \sqrt{1 - \frac{1}{5}} + \frac{1}{\sqrt{5}} \sqrt{1 - \frac{4}{5}}\right) - \frac{1}{2} \\
 &= \frac{5}{2} \sin^{-1}(1) - \frac{1}{2} = \left(\frac{5\pi}{4} - \frac{1}{2}\right) \text{ sq units}
 \end{aligned}$$

56. Given, $y = \begin{cases} \tan x, & -\frac{\pi}{3} \leq x \leq \frac{\pi}{3} \\ \cot x, & \frac{\pi}{6} \leq x \leq \frac{\pi}{2} \end{cases}$

which could be plotted as Y-axis.

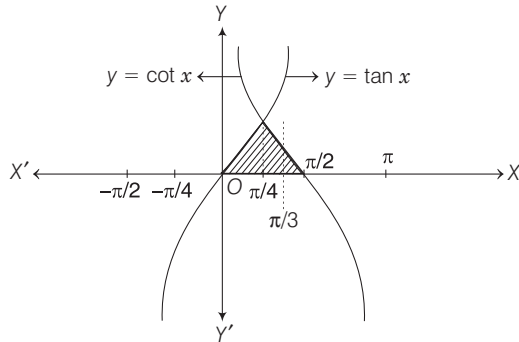

$$\begin{aligned}
 \therefore \text{ Required area} &= \int_0^{\pi/4} (\tan x) dx + \int_{\pi/4}^{\pi/3} (\cot x) dx \\
 &= [-\log |\cos x|]_0^{\pi/4} + [\log \sin x]_{\pi/4}^{\pi/3} \\
 &= -\left(\log \frac{1}{\sqrt{2}} - 0\right) + \left(\log \frac{\sqrt{3}}{2} - \log \frac{1}{\sqrt{2}}\right) \\
 &= \log \frac{\sqrt{3}}{2} - 2 \log \frac{1}{\sqrt{2}} \\
 &= \log \frac{\sqrt{3}}{2} - \log \frac{1}{2} = \left(\frac{1}{2} \log_e 3\right) \text{ sq units}
 \end{aligned}$$

57. Here, $\int_2^a \left(1 + \frac{8}{x^2}\right) dx = \int_a^4 \left(1 + \frac{8}{x^2}\right) dx$

$$\begin{aligned}
 \Rightarrow & \left[x - \frac{8}{x}\right]_2^a = \left[x - \frac{8}{x}\right]_a^4 \\
 \Rightarrow & \left(a - \frac{8}{a}\right) - (2 - 4) = (4 - 2) - \left(a - \frac{8}{a}\right) \\
 \Rightarrow & a - \frac{8}{a} + 2 = 2 - a + \frac{8}{a} \\
 \Rightarrow & 2a - \frac{16}{a} = 0 \Rightarrow 2(a^2 - 8) = 0 \\
 \Rightarrow & a = \pm 2\sqrt{2} \quad [\text{neglecting } -ve \text{ sign}] \\
 \therefore & a = 2\sqrt{2}
 \end{aligned}$$

58. The point of intersection of the curves $x^2 = 4y$ and $x = 4y - 2$ could be sketched are $x = -1$ and $x = 2$.

\therefore Required area

$$\begin{aligned}
 &= \int_{-1}^2 \left\{ \left(\frac{x+2}{4}\right) - \left(\frac{x^2}{4}\right) \right\} dx \\
 &= \frac{1}{4} \left[\frac{x^2}{2} + 2x - \frac{x^3}{3} \right]_{-1}^2 \\
 &= \frac{1}{4} \left[\left(2 + 4 - \frac{8}{3}\right) - \left(\frac{1}{2} - 2 + \frac{1}{3}\right) \right] \\
 &= \frac{1}{4} \left[\frac{10}{3} - \left(-\frac{7}{6}\right) \right] = \frac{1}{4} \cdot \frac{9}{2} = \frac{9}{8} \text{ sq units}
 \end{aligned}$$

59. Let $P = \left(\frac{e^{t_1} + e^{-t_1}}{2}, \frac{e^{t_1} - e^{-t_1}}{2}\right)$

and $Q = \left(\frac{e^{-t} + e^{t_1}}{2}, \frac{e^{-t_1} - e^{-t}}{2}\right)$

We have to find the area of the region bounded by the curve $x^2 - y^2 = 1$ and the lines joining the centre $x = 0$, $y = 0$ to the points (t_1) and $(-t_1)$.

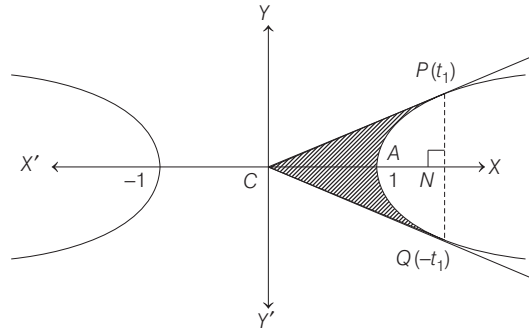

Required area

$$\begin{aligned}
 &= 2 \left[\text{area of } \triangle PCN - \int_1^{\frac{e^{t_1} + e^{-t_1}}{2}} \frac{y dx}{2} \right] \\
 &= 2 \left[\frac{1}{2} \left(\frac{e^{t_1} + e^{-t_1}}{2}\right) \left(\frac{e^{t_1} - e^{-t_1}}{2}\right) - \int_1^{t_1} y \frac{dy}{dt} \cdot dt \right] \\
 &= 2 \left[\frac{e^{2t_1} - e^{-2t_1}}{8} - \int_0^{t_1} \left(\frac{e^t - e^{-t}}{2}\right) dt \right] \\
 &= \frac{e^{2t_1} - e^{-2t_1}}{4} - \frac{1}{2} \int_0^{t_1} (e^{2t} + e^{-2t} - 2) dt \\
 &= \frac{e^{2t_1} - e^{-2t_1}}{4} - \frac{1}{2} \left[\frac{e^{2t}}{2} - \frac{e^{-2t}}{2} - 2t \right] \\
 &= \frac{e^{2t_1} - e^{-2t_1}}{4} - \frac{1}{4} (e^{2t_1} - e^{-2t_1} - 4t_1)
 \end{aligned}$$

14

Differential Equations

Topic 1 Solution of Differential Equations by Variable Separation Method

Objective Questions I (Only one correct option)

1. The solution curve of the differential equation, $(1 + e^{-x})(1 + y^2) \frac{dy}{dx} = y^2$, which passes through the point $(0, 1)$ is (2020 Main, 3 Sep I)

(a) $y^2 + 1 = y \left(\log_e \left(\frac{1 + e^{-x}}{2} \right) + 2 \right)$

(b) $y^2 + 1 = y \left(\log_e \left(\frac{1 + e^x}{2} \right) + 2 \right)$

(c) $y^2 = 1 + y \log_e \left(\frac{1 + e^x}{2} \right)$

(d) $y^2 = 1 + y \log_e \left(\frac{1 + e^{-x}}{2} \right)$

2. Let f be a differentiable function such that $f(1) = 2$ and $f'(x) = f(x)$ for all $x \in R$. If $h(x) = f(f(x))$, then $h'(1)$ is equal to (2019 Main, 12 Jan II)
- (a) $4e^2$ (b) $4e$ (c) $2e$ (d) $2e^2$

3. The solution of the differential equation, $\frac{dy}{dx} = (x - y)^2$, when $y(1) = 1$, is (2019 Main, 11 Jan II)

(a) $\log_e \left| \frac{2 - y}{2 - x} \right| = 2(y - 1)$

(b) $-\log_e \left| \frac{1 + x - y}{1 - x + y} \right| = x + y - 2$

(c) $\log_e \left| \frac{2 - x}{2 - y} \right| = x - y$

(d) $-\log_e \left| \frac{1 - x + y}{1 + x - y} \right| = 2(x - 1)$

4. Let $f: [0, 1] \rightarrow R$ be such that $f(xy) = f(x) \cdot f(y)$, for all $x, y \in [0, 1]$ and $f(0) \neq 0$. If $y = y(x)$ satisfies the differential equation, $\frac{dy}{dx} = f(x)$ with $y(0) = 1$, then $y\left(\frac{1}{4}\right) + y\left(\frac{3}{4}\right)$ is equal to (2019 Main, 9 Jan II)
- (a) 5 (b) 3 (c) 2 (d) 4

5. If $(2 + \sin x) \frac{dy}{dx} + (y + 1) \cos x = 0$ and $y(0) = 1$, then $y\left(\frac{\pi}{2}\right)$ is equal to (2017 Main)
- (a) $\frac{1}{3}$ (b) $-\frac{2}{3}$ (c) $-\frac{1}{3}$ (d) $\frac{4}{3}$

6. If $y = y(x)$ satisfies the differential equation $8\sqrt{x}(\sqrt{9 + \sqrt{x}}) dy = (\sqrt{4 + \sqrt{9 + \sqrt{x}}})^{-1} dx$, $x > 0$ and $y(0) = \sqrt{7}$, then $y(256) =$ (2017 Adv.)
- (a) 16 (b) 3 (c) 9 (d) 80

7. The value of $\sum_{k=1}^{13} \frac{1}{\sin\left(\frac{\pi}{4} + \frac{(k-1)\pi}{6}\right) \sin\left(\frac{\pi}{4} + \frac{k\pi}{6}\right)}$ is equal to (2016 Adv.)
- (a) $3 - \sqrt{3}$ (b) $2(3 - \sqrt{3})$
(c) $2(\sqrt{3} - 1)$ (d) $2(2 + \sqrt{3})$

8. The differential equation $\frac{dy}{dx} = \frac{\sqrt{1 - y^2}}{y}$ determines a family of circles with (2007, 3M)
- (a) variable radii and a fixed centre at $(0, 1)$
(b) variable radii and a fixed centre at $(0, -1)$
(c) fixed radius 1 and variable centres along the X -axis
(d) fixed radius 1 and variable centres along the Y -axis

9. If $y = y(x)$ and $\frac{2 + \sin x}{y + 1} \left(\frac{dy}{dx} \right) = -\cos x$, $y(0) = 1$, then $y\left(\frac{\pi}{2}\right)$ equals (2004, 1M)
- (a) $1/3$ (b) $2/3$ (c) $-1/3$ (d) 1

10. A solution of the differential equation $\left(\frac{dy}{dx}\right)^2 - x \frac{dy}{dx} + y = 0$ is (1999, 2M)
- (a) $y = 2$ (b) $y = 2x$ (c) $y = 2x - 4$ (d) $y = 2x^2 - 4$

11. The order of the differential equation whose general solution is given by $y = (c_1 + c_2) \cos(x + c_3) - c_4 e^{x + c_5}$, where c_1, c_2, c_3, c_4, c_5 are arbitrary constants, is (1998, 2M)
- (a) 5 (b) 4 (c) 3 (d) 2

Objective Questions II

(One or more than one correct option)

12. Let b be a nonzero real number. Suppose $f : \mathbf{R} \rightarrow \mathbf{R}$ is a differentiable function such that $f(0) = 1$. If the derivative f' of f satisfies the equation

$$f'(x) = \frac{f(x)}{b^2 + x^2}$$

for all $x \in \mathbf{R}$, then which of the following statements is/are TRUE? (2020 Adv.)

- (a) If $b > 0$, then f is an increasing function
- (b) If $b < 0$, then f is a decreasing function
- (c) $f(x)f(-x) = 1$ for all $x \in \mathbf{R}$
- (d) $f(x) - f(-x) = 0$ for all $x \in \mathbf{R}$

13. Let $f : [0, \infty) \rightarrow \mathbf{R}$ be a continuous function such that $f(x) = 1 - 2x + \int_0^x e^{x-t} f(t) dt$ for all $x \in [0, \infty)$. Then, which of the following statement(s) is (are) TRUE? (2018 Adv.)

- (a) The curve $y = f(x)$ passes through the point $(1, 2)$
- (b) The curve $y = f(x)$ passes through the point $(2, -1)$
- (c) The area of the region $\{(x, y) \in [0, 1] \times \mathbf{R} : f(x) \leq y \leq \sqrt{1-x^2}\}$ is $\frac{\pi - 2}{4}$
- (d) The area of the region $\{(x, y) \in [0, 1] \times \mathbf{R} : f(x) \leq y \leq \sqrt{1-x^2}\}$ is $\frac{\pi - 1}{4}$

14. Let $y(x)$ be a solution of the differential equation $(1 + e^x)y' + ye^x = 1$. If $y(0) = 2$, then which of the following statement(s) is/are true? (2015 Adv.)

- (a) $y(-4) = 0$
- (b) $y(-2) = 0$
- (c) $y(x)$ has a critical point in the interval $(-1, 0)$
- (d) $y(x)$ has no critical point in the interval $(-1, 0)$

15. Consider the family of all circles whose centres lie on the straight line $y = x$. If this family of circles is represented by the differential equation $P'y' + Qy' + 1 = 0$, where P, Q are the functions of x, y and y' (here, $y' = \frac{dy}{dx}$, $y'' = \frac{d^2y}{dx^2}$), then which of the following statement(s) is/are true? (2015 Adv.)

- (a) $P = y + x$
- (b) $P = y - x$
- (c) $P + Q = 1 - x + y + y' + (y')^2$
- (d) $P - Q = x + y - y' - (y')^2$

16. The differential equation representing the family of curves $y^2 = 2c(x + \sqrt{c})$, where c is a positive parameter, is of (1999, 3M)

- (a) order 1
- (b) order 2
- (c) degree 3
- (d) degree 4

Integer & Numerical Answer Type Questions

17. Let $f : \mathbf{R} \rightarrow \mathbf{R}$ be a differentiable function with $f(0) = 0$. If $y = f(x)$ satisfies the differential equation $\frac{dy}{dx} = (2 + 5y)(5y - 2)$, then the value of $\lim_{x \rightarrow -\infty} f(x)$ is (2018 Adv.)
18. Let $f : \mathbf{R} \rightarrow \mathbf{R}$ be a continuous function, which satisfies $f(x) = \int_0^x f(t) dt$. Then, the value of $f(\ln 5)$ is ... (2009)

Assertion and Reason

For the following question, choose the correct answer from the codes (a), (b), (c) and (d) defined as follows.

- (a) Statement I is true, Statement II is also true; Statement II is the correct explanation of Statement I.
- (b) Statement I is true, Statement II is also true; Statement II is not the correct explanation of Statement I.
- (c) Statement I is true; Statement II is false.
- (d) Statement I is false; Statement II is true.

19. Let a solution $y = y(x)$ of the differential equation $x\sqrt{x^2 - 1} dy - y\sqrt{y^2 - 1} dx = 0$ satisfy $y(2) = \frac{2}{\sqrt{3}}$

Statement I $y(x) = \sec\left(\sec^{-1} x - \frac{\pi}{6}\right)$ and

Statement II $y(x)$ is given by $\frac{1}{y} = \frac{2\sqrt{3}}{x} - \sqrt{1 - \frac{1}{x^2}}$ (2008, 3M)

Analytical & Descriptive Questions

20. If $P(1) = 0$ and $\frac{dP(x)}{dx} > P(x), \forall x \geq 1$, then prove that $P(x) > 0, \forall x > 1$. (2003, 4M)
21. Let $y = f(x)$ be a curve passing through $(1, 1)$ such that the triangle formed by the coordinate axes and the tangent at any point of the curve lies in the first quadrant and has area 2 unit. Form the differential equation and determine all such possible curves. (1995, 5M)

Passage Based Problems

Passage

Let $f : [0, 1] \rightarrow \mathbf{R}$ (the set of all real numbers) be a function. Suppose the function f is twice differentiable, $f(0) = f(1) = 0$ and satisfies

$$f''(x) - 2f'(x) + f(x) \geq e^x, x \in [0, 1] \quad (2013 Adv.)$$

356 Differential Equations

22. If the function $e^{-x}f(x)$ assumes its minimum in the interval $[0, 1]$ at $x = 1/4$, then which of the following is true?
 (a) $f'(x) < f(x)$, $\frac{1}{4} < x < \frac{3}{4}$ (b) $f'(x) > f(x)$, $0 < x < \frac{1}{4}$
 (c) $f'(x) < f(x)$, $0 < x < \frac{1}{4}$ (d) $f'(x) < f(x)$, $\frac{3}{4} < x < 1$
23. Which of the following is true?
 (a) $0 < f(x) < \infty$ (b) $-\frac{1}{2} < f(x) < \frac{1}{2}$
 (c) $-\frac{1}{4} < f(x) < 1$ (d) $-\infty < f(x) < 0$
24. Which of the following is true?
 (a) g is increasing on $(1, \infty)$
 (b) g is decreasing on $(1, \infty)$
 (c) g is increasing on $(1, 2)$ and decreasing on $(2, \infty)$
 (d) g is decreasing on $(1, 2)$ and increasing on $(2, \infty)$
25. Consider the statements.
 I. There exists some $x \in R$ such that, $f(x) + 2x = 2(1 + x^2)$
 II. There exists some $x \in R$ such that,
 $2f(x) + 1 = 2x(1 + x)$
 (a) Both I and II are true (b) I is true and II is false
 (c) I is false and II is true (d) Both I and II are false

Topic 2 Linear Differential Equation and Exact Differential Equation

Objective Questions I (Only one correct option)

1. The general solution of the differential equation $(y^2 - x^3)dx - xydy = 0$ ($x \neq 0$) is (where, C is a constant of integration) (2019 Main, 12 April II)
 (a) $y^2 - 2x^2 + Cx^3 = 0$ (b) $y^2 + 2x^3 + Cx^2 = 0$
 (c) $y^2 + 2x^2 + Cx^3 = 0$ (d) $y^2 - 2x^3 + Cx^2 = 0$
2. Consider the differential equation, $y^2dx + \left(x - \frac{1}{y}\right)dy = 0$.
 If value of y is 1 when $x = 1$, then the value of x for which $y = 2$, is (2019 Main, 12 April I)
 (a) $\frac{5}{2} + \frac{1}{\sqrt{e}}$ (b) $\frac{3}{2} - \frac{1}{\sqrt{e}}$ (c) $\frac{1}{2} + \frac{1}{\sqrt{e}}$ (d) $\frac{3}{2} - \sqrt{e}$
3. Let $y = y(x)$ be the solution of the differential equation, $\frac{dy}{dx} + y \tan x = 2x + x^2 \tan x$, $x \in \left(-\frac{\pi}{2}, \frac{\pi}{2}\right)$, such that $y(0) = 1$. Then (2019 Main, 10 April II)
 (a) $y'\left(\frac{\pi}{4}\right) - y'\left(-\frac{\pi}{4}\right) = \pi - \sqrt{2}$ (b) $y'\left(\frac{\pi}{4}\right) + y'\left(-\frac{\pi}{4}\right) = -\sqrt{2}$
 (c) $y\left(\frac{\pi}{4}\right) + y\left(-\frac{\pi}{4}\right) = \frac{\pi^2}{2} + 2$ (d) $y\left(\frac{\pi}{4}\right) - y\left(-\frac{\pi}{4}\right) = \sqrt{2}$
4. If $y = y(x)$ is the solution of the differential equation $\frac{dy}{dx} = (\tan x - y) \sec^2 x$, $x \in \left(-\frac{\pi}{2}, \frac{\pi}{2}\right)$, such that $y(0) = 0$, then $y\left(-\frac{\pi}{4}\right)$ is equal to (2019 Main, 10 April I)
 (a) $\frac{1}{e} - 2$ (b) $\frac{1}{2} - e$ (c) $2 + \frac{1}{e}$ (d) $e - 2$
5. If $\cos x \frac{dy}{dx} - y \sin x = 6x$, $\left(0 < x < \frac{x}{2}\right)$ and $y\left(\frac{\pi}{3}\right) = 0$, then $y\left(\frac{\pi}{6}\right)$ is equal to (2019 Main, 9 April II)
 (a) $\frac{\pi^2}{2\sqrt{3}}$ (b) $-\frac{\pi^2}{2\sqrt{3}}$ (c) $-\frac{\pi^2}{4\sqrt{3}}$ (d) $-\frac{\pi^2}{2}$
6. The solution of the differential equation $x \frac{dy}{dx} + 2y = x^2(x \neq 0)$ with $y(1) = 1$, is (2019 Main, 9 April I)
 (a) $y = \frac{x^2}{4} + \frac{3}{4x^2}$ (b) $y = \frac{x^3}{5} + \frac{1}{5x^2}$
 (c) $y = \frac{3}{4}x^2 + \frac{1}{4x^2}$ (d) $y = \frac{4}{5}x^3 + \frac{1}{5x^2}$
7. Let $y = y(x)$ be the solution of the differential equation, $(x^2 + 1)^2 \frac{dy}{dx} + 2x(x^2 + 1)y = 1$ such that $y(0) = 0$. If $\sqrt{a} y(1) = \frac{\pi}{32}$, then the value of 'a' is (2019 Main, 8 April I)
 (a) $\frac{1}{4}$ (b) $\frac{1}{2}$ (c) 1 (d) $\frac{1}{16}$
8. If a curve passes through the point $(1, -2)$ and has slope of the tangent at any point (x, y) on it as $\frac{x^2 - 2y}{x}$, then the curve also passes through the point (2019 Main, 12 Jan II)
 (a) $(\sqrt{3}, 0)$ (b) $(-1, 2)$ (c) $(-\sqrt{2}, 1)$ (d) $(3, 0)$
9. Let $y = y(x)$ be the solution of the differential equation, $x \frac{dy}{dx} + y = x \log_e x$, ($x > 1$). If $2y(2) = \log_e 4 - 1$, then $y(e)$ is equal to (2019 Main, 12 Jan I)
 (a) $-\frac{e}{2}$ (b) $-\frac{e^2}{2}$ (c) $\frac{e}{4}$ (d) $\frac{e^2}{4}$
10. If $y(x)$ is the solution of the differential equation $\frac{dy}{dx} + \left(\frac{2x+1}{x}\right)y = e^{-2x}$, $x > 0$, where $y(1) = \frac{1}{2}e^{-2}$, then (2019 Main, 11 Jan I)
 (a) $y(x)$ is decreasing in $\left(\frac{1}{2}, 1\right)$
 (b) $y(x)$ is decreasing in $(0, 1)$
 (c) $y(\log_e 2) = \log_e 4$
 (d) $y(\log_e 2) = \frac{\log_e 2}{4}$

11. Let f be a differentiable function such that $f'(x) = 7 - \frac{3}{4} \frac{f(x)}{x}$, ($x > 0$) and $f(1) \neq 4$. Then, $\lim_{x \rightarrow 0^+} x f\left(\frac{1}{x}\right)$

(2019 Main, 10 Jan II)

- (a) does not exist (b) exists and equals $\frac{4}{7}$
 (c) exists and equals 0 (d) exists and equals 4

12. If $\frac{dy}{dx} + \frac{3}{\cos^2 x} y = \frac{1}{\cos^2 x}$, $x \in \left(-\frac{\pi}{3}, \frac{\pi}{3}\right)$ and $y\left(\frac{\pi}{4}\right) = \frac{4}{3}$, then $y\left(-\frac{\pi}{4}\right)$ equals

(2019 Main, 10 Jan I)

- (a) $\frac{1}{3} + e^6$ (b) $-\frac{4}{3}$ (c) $\frac{1}{3} + e^3$ (d) $\frac{1}{3}$

13. If $y = y(x)$ is the solution of the differential equation, $x \frac{dy}{dx} + 2y = x^2$ satisfying $y(1) = 1$, then $y\left(\frac{1}{2}\right)$ is equal to

(2019 Main, 9 Jan I)

- (a) $\frac{13}{16}$ (b) $\frac{1}{4}$ (c) $\frac{49}{16}$ (d) $\frac{7}{64}$

14. Let $y = y(x)$ be the solution of the differential equation $\sin x \frac{dy}{dx} + y \cos x = 4x$, $x \in (0, \pi)$.

If $y\left(\frac{\pi}{2}\right) = 0$, then $y\left(\frac{\pi}{6}\right)$ is equal to

(2018 Main)

- (a) $\frac{4}{9\sqrt{3}} \pi^2$ (b) $\frac{-8}{9\sqrt{3}} \pi^2$ (c) $-\frac{8}{9} \pi^2$ (d) $-\frac{4}{9} \pi^2$

15. If a curve $y = f(x)$ passes through the point $(1, -1)$ and satisfies the differential equation, $y(1 + xy)dx = x dy$, then $f\left(-\frac{1}{2}\right)$ is equal to

(2016 Main)

- (a) $-\frac{2}{5}$ (b) $-\frac{4}{5}$ (c) $\frac{2}{5}$ (d) $\frac{4}{5}$

16. Let $y(x)$ be the solution of the differential equation $(x \log x) \frac{dy}{dx} + y = 2x \log x$, ($x \geq 1$). Then, $y(e)$ is equal to

(2015 Main)

- (a) e (b) 0 (c) 2 (d) 2e

17. The function $y = f(x)$ is the solution of the differential equation $\frac{dy}{dx} + \frac{xy}{x^2 - 1} = \frac{x^4 + 2x}{\sqrt{1 - x^2}}$ in $(-1, 1)$ satisfying

$f(0) = 0$. Then, $\int_{-\frac{\sqrt{3}}{2}}^{\frac{\sqrt{3}}{2}} f(x) dx$ is

(2014 Adv.)

- (a) $\frac{\pi}{3} - \frac{\sqrt{3}}{2}$ (b) $\frac{\pi}{3} - \frac{\sqrt{3}}{4}$ (c) $\frac{\pi}{6} - \frac{\sqrt{3}}{4}$ (d) $\frac{\pi}{6} - \frac{\sqrt{3}}{2}$

18. Let $f: [1/2, 1] \rightarrow R$ (the set of all real numbers) be a positive, non-constant and differentiable function such that $f'(x) < 2f(x)$ and $f(1/2) = 1$. Then, the value of $\int_{1/2}^1 f(x) dx$ lies in the interval

(2013 Adv.)

- (a) $(2e - 1, 2e)$ (b) $(e - 1, 2e - 1)$
 (c) $\left(\frac{e - 1}{2}, e - 1\right)$ (d) $\left(0, \frac{e - 1}{2}\right)$

19. Let $f(x)$ be differentiable on the interval $(0, \infty)$ such that $f(1) = 1$, and $\lim_{t \rightarrow x} \frac{t^2 f(x) - x^2 f(t)}{t - x} = 1$ for each $x > 0$. Then,

$f(x)$ is

(2007, 3M)

- (a) $\frac{1}{3x} + \frac{2x^2}{3}$ (b) $-\frac{1}{3x} + \frac{4x^2}{3}$
 (c) $-\frac{1}{x} + \frac{2}{x^2}$ (d) $\frac{1}{x}$

20. If $x dy = y(dx + y dy)$, $y(1) = 1$ and $y(x) > 0$. Then, $y(-3)$ is equal to

(2005, 1M)

- (a) 3 (b) 2
 (c) 1 (d) 0

21. If $y(t)$ is a solution of $(1 + t) \frac{dy}{dt} - ty = 1$ and $y(0) = -1$, then $y(1)$ is equal to

(2003, 1M)

- (a) $-1/2$ (b) $e + 1/2$
 (c) $e - 1/2$ (d) $1/2$

Objective Questions II

(One or more than one correct option)

22. Let $f: (0, \infty) \rightarrow R$ be a differentiable function such that $f'(x) = 2 - \frac{f(x)}{x}$ for all $x \in (0, \infty)$ and $f(1) \neq 1$. Then

(2016 Adv.)

- (a) $\lim_{x \rightarrow 0^+} f\left(\frac{1}{x}\right) = 1$
 (b) $\lim_{x \rightarrow 0^+} x f\left(\frac{1}{x}\right) = 2$
 (c) $\lim_{x \rightarrow 0^+} x^2 f'(x) = 0$
 (d) $|f(x)| \leq 2$ for all $x \in (0, 2)$

23. If $y(x)$ satisfies the differential equation $y' - y \tan x = 2 x \sec x$ and $y(0) = 1$, then

(2012)

- (a) $y\left(\frac{\pi}{4}\right) = \frac{\pi^2}{8\sqrt{2}}$ (b) $y'\left(\frac{\pi}{4}\right) = \frac{\pi^2}{18}$
 (c) $y\left(\frac{\pi}{3}\right) = \frac{\pi^2}{9}$ (d) $y'\left(\frac{\pi}{3}\right) = \frac{4\pi}{3} + \frac{2\pi^2}{3\sqrt{3}}$

Analytical & Descriptive Question

24. Let $u(x)$ and $v(x)$ satisfy the differential equations $\frac{du}{dx} + p(x)u = f(x)$ and $\frac{dv}{dx} + p(x)v = g(x)$, where $p(x)$, $f(x)$ and $g(x)$ are continuous functions. If $u(x_1) > v(x_1)$ for some x_1 and $f(x) > g(x)$ for all $x > x_1$, prove that any point (x, y) where $x > x_1$ does not satisfy the equations $y = u(x)$ and $y = v(x)$. (1997, 5M)

Integer & Numerical Answer Type Question

25. Let $y'(x) + y(x)g'(x) = g(x)g'(x)$, $y(0) = 0$, $x \in R$, where $f'(x)$ denotes $\frac{df(x)}{dx}$ and $g(x)$ is a given non-constant differentiable function on R with $g(0) = g(2) = 0$. Then, the value of $y(2)$ is (2011)

Topic 3 Applications of Homogeneous Differential Equations

Objective Questions I (Only one correct option)

1. If a curve $y = f(x)$, passing through the point $(1, 2)$, is the solution of the differential equation, $2x^2 dy = (2xy + y^2) dx$, then $f\left(\frac{1}{2}\right)$ is equal to

(a) $\frac{1}{1 + \log_e 2}$ (b) $\frac{1}{1 - \log_e 2}$ (c) $1 + \log_e 2$ (d) $\frac{-1}{1 + \log_e 2}$ (2020 Main, 2 Sep II)

2. Given that the slope of the tangent to a curve $y = y(x)$ at any point (x, y) is $\frac{2y}{x^2}$. If the curve passes through the centre of the circle $x^2 + y^2 - 2x - 2y = 0$, then its equation is (2019 Main, 8 April II)

(a) $x^2 \log_e |y| = -2(x - 1)$ (b) $x \log_e |y| = x - 1$
(c) $x \log_e |y| = 2(x - 1)$ (d) $x \log_e |y| = -2(x - 1)$

3. The curve amongst the family of curves represented by the differential equation, $(x^2 - y^2) dx + 2xy dy = 0$, which passes through $(1, 1)$, is (2019 Main, 10 Jan II)

- (a) a circle with centre on the Y-axis
(b) a circle with centre on the X-axis
(c) an ellipse with major axis along the Y-axis
(d) a hyperbola with transverse axis along the X-axis.

4. Let the population of rabbits surviving at a time t , be governed by the differential equation $\frac{dp(t)}{dt} = \frac{1}{2} p(t) - 200$. If $p(0) = 100$, then $p(t)$ is equal to

(a) $400 - 300e^{\frac{t}{2}}$ (b) $300 - 200e^{-\frac{t}{2}}$
(c) $600 - 500e^{\frac{t}{2}}$ (d) $400 - 300e^{-\frac{t}{2}}$ (2014 Main)

5. A curve passes through the point $\left(1, \frac{\pi}{6}\right)$. Let the slope of the curve at each point (x, y) be $\frac{y}{x} + \sec\left(\frac{y}{x}\right)$, $x > 0$.

Then, the equation of the curve is (2013 Adv.)

(a) $\sin\left(\frac{y}{x}\right) = \log x + \frac{1}{2}$ (b) $\operatorname{cosec}\left(\frac{y}{x}\right) = \log x + 2$
(c) $\sec\left(\frac{2y}{x}\right) = \log x + 2$ (d) $\cos\left(\frac{2y}{x}\right) = \log x + \frac{1}{2}$

6. At present, a firm is manufacturing 2000 items. It is estimated that the rate of change of production P with respect to additional number of workers x is given by $\frac{dP}{dx} = 100 - 12\sqrt{x}$. If the firm employs 25 more workers, then the new level of production of items is

(a) 2500 (b) 3000 (c) 3500 (d) 4500 (2013 Main)

Objective Questions II

(One or more than one correct option)

7. Let Γ denote a curve $y = y(x)$ which is in the first quadrant and let the point $(1, 0)$ lie on it. Let the tangent to Γ at a point P intersect the y -axis at Y_P . If PY_P has length 1 for each point P on Γ , then which of the following options is/are correct? (2019 Adv.)

(a) $xy' + \sqrt{1 - x^2} = 0$ (b) $xy' - \sqrt{1 - x^2} = 0$

(c) $y = \log_e \left(\frac{1 + \sqrt{1 - x^2}}{x} \right) - \sqrt{1 - x^2}$

(d) $y = -\log_e \left(\frac{1 + \sqrt{1 - x^2}}{x} \right) + \sqrt{1 - x^2}$

8. A solution curve of the differential equation $(x^2 + xy + 4x + 2y + 4) \frac{dy}{dx} - y^2 = 0$, $x > 0$, passes through the point $(1, 3)$. Then, the solution curve (2016 Adv.)

- (a) intersects $y = x + 2$ exactly at one point
(b) intersects $y = x + 2$ exactly at two points
(c) intersects $y = (x + 2)^2$
(d) does not intersect $y = (x + 3)^2$

9. Tangent is drawn at any point P of a curve which passes through $(1, 1)$ cutting X-axis and Y-axis at A and B , respectively. If $BP : AP = 3 : 1$, then (2006, 3M)

- (a) differential equation of the curve is $3x \frac{dy}{dx} + y = 0$
(b) differential equation of the curve is $3x \frac{dy}{dx} - y = 0$

(c) curve is passing through $\left(\frac{1}{8}, 2\right)$

- (d) normal at $(1, 1)$ is $x + 3y = 4$

Fill in the Blank

10. A spherical rain drop evaporates at a rate proportional to its surface area at any instant t . The differential equation giving the rate of change of the rains of the rain drop is (1997C, 2M)

Analytical & Descriptive Questions

11. If length of tangent at any point on the curve $y = f(x)$ intercepted between the point and the X-axis is of length 1. Find the equation of the curve. (2005, 4M)

12. A right circular cone with radius R and height H contains a liquid which evaporates at a rate proportional to its surface area in contact with air (proportionality constant = $k > 0$). Find the time after which the cone is empty. (2003, 4M)

13. A hemispherical tank of radius 2 m is initially full of water and has an outlet of 12 cm^2 cross-sectional area at the bottom. The outlet is opened at some instant. The flow through the outlet is according to the law $v(t) = 0.6 \sqrt{2gh(t)}$, where $v(t)$ and $h(t)$ are respectively the velocity of the flow through the outlet and the height of water level above the outlet at time t and g is the acceleration due to gravity. Find the time it takes to empty the tank. (2001, 10M)

Hint Form a differential equation by relating the decreases of water level to the outflow.

14. A country has food deficit of 10%. Its population grows continuously at a rate of 3% per year. Its annual food production every year is 4% more than that of the last year. Assuming that the average food requirement per person remains constant, prove that the country will become self-sufficient in food after n years, where n is the smallest integer bigger than or equal to $\frac{\ln 10 - \ln 9}{\ln(1.04) - (0.03)}$. (2000, 10M)

15. A curve passing through the point (1, 1) has the property that the perpendicular distance of the origin from the normal at any point P of the curve is equal to the distance of P from the X -axis. Determine the equation of the curve. (1999, 10M)
16. A and B are two separate reservoirs of water. Capacity of reservoir A is double the capacity of reservoir B . Both the reservoirs are filled completely with water, their inlets are closed and then the water is released simultaneously from both the reservoirs. The rate of flow of water out of each reservoir at any instant of time is proportional to the quantity of water in the reservoir at the time. One hour after the water is released, the quantity of water in reservoir A is $1\frac{1}{2}$ times the quantity of water in reservoir B . After how many hours do both the reservoirs have the same quantity of water? (1997, 7M)
17. Determine the equation of the curve passing through the origin in the form $y = f(x)$, which satisfies the differential equation $\frac{dy}{dx} = \sin(10x + 6y)$ (1996, 5M)

Match the Columns

18. Match the conditions/expressions in Column I with statements in Column II. (2006, 6M)

Column I	Column II
A. $\int_0^{\pi/2} (\sin x)^{\cos x} \{ \cos x \cot x - \log(\sin x)^{\sin x} \} dx$	p. 1
B. Area bounded by $-4y^2 = x$ and $x - 1 = -5y^2$	q. 0
C. The angle of intersection of curves $y = 3^{x-1} \log x$ and $y = x^x - 1$ is	r. $3e^{y/2}$
D. If $\frac{dy}{dx} = \frac{2}{x+y}$ passing through (1, 0), then $(x + y + 2)$ is	s. $\frac{4}{3}$

Answers

Topic 1

1. (c) 2. (b) 3. (d) 4. (b)
 5. (a) 6. (b) 7. (c) 8. (c)
 9. (a) 10. (c) 11. (c) 12. (a,c)
 13. (b, c) 14. (a, c) 15. (b, c)
 16. (a, c) 17. (0.40) 18. (0) 19. (b)

21. Differential Equation: $\frac{d^2y}{dx^2} = 0, x^2 \frac{dy}{dx} + 1 = 0$

Curves : $x + y = 2, xy = 1$

22. (c) 23. (d) 24. (b)
 25. (c)

Topic 2

1. (b) 2. (b) 3. (a) 4. (d)
 5. (b) 6. (a) 7. (d) 8. (a)
 9. (c) 10. (a) 11. (d) 12. (a)
 13. (c) 14. (c) 15. (d) 16. (c)
 17. (b) 18. (d) 19. (a) 20. (a)

21. (a) 22. (a) 23. (a, d) 25. (0)

Topic 3

1. (a) 2. (c) 3. (b) 4. (a)
 5. (a) 6. (c) 7. (a,c)
 8. (a, d) 9. (a, c)

10. $\left(\frac{dr}{dt} = -\lambda\right)$ 11. $\left(\sqrt{1-y^2} - \log \left| \frac{1+\sqrt{1-y^2}}{1-\sqrt{1-y^2}} \right| = \pm x + c\right)$

12. $\left(T = \frac{H}{k}\right)$ 13. $\left(\frac{14\pi \times 10^5}{27\sqrt{g}} \text{ unit}\right)$

15. $(x^2 + y^2 = 2x)$ 16. $\left(\log_3 \left[\frac{1}{2}\right]\right)$

17. $\frac{1}{3} \tan^{-1} \left[\frac{4}{5} \tan \left(4x + \tan^{-1} \frac{3}{4} \right) - \frac{3}{5} \right] - \frac{5x}{3}$

18. $A \rightarrow p; B \rightarrow s; C \rightarrow q; D \rightarrow r$

Hints & Solutions

Topic 1 Solution of Differential Equations by Variable Separation Method

1. Given differential equation

$$(1 + e^{-x})(1 + y^2) \frac{dy}{dx} = y^2$$

$$\Rightarrow \int \frac{1 + y^2}{y^2} dy = \int \frac{e^x}{1 + e^x} dx$$

$$\Rightarrow \left(-\frac{1}{y} + y\right) = \log_e(1 + e^x) + C,$$

which passes through (0, 1),
so $-1 + 1 = \log_e 2 + C \Rightarrow C = -\log_e 2$
So, equation of required curve is

$$y^2 = 1 + y \log_e \left(\frac{1 + e^x}{2}\right)$$

Hence, option (c) is correct.

2. Given that, $f'(x) = f(x)$

$$\Rightarrow \frac{f'(x)}{f(x)} = 1$$

$$\Rightarrow \int \frac{f'(x)}{f(x)} dx = \int 1 \cdot dx$$

[by integrating both sides w.r.t. x]

$$\Rightarrow \text{Put } f(x) = t \Rightarrow f'(x) dx = dt$$

$$\therefore \int \frac{dt}{t} = \int 1 dx$$

$$\Rightarrow \ln |t| = x + C \quad \left[\because \int \frac{dx}{x} = \ln |x| + C \right]$$

$$\Rightarrow \ln |f(x)| = x + C \quad \begin{array}{l} \dots(i) \\ [\because t = f(x)] \end{array}$$

$$\therefore f(1) = 2$$

So, $\ln(2) = 1 + C$ [using Eq. (i)]

$$\Rightarrow C = \ln 2 - \ln e \quad [\because \ln e = 1]$$

$$\Rightarrow C = \ln \left(\frac{2}{e}\right) \quad [\because \ln A - \ln B = \ln \left(\frac{A}{B}\right)]$$

From Eq. (i), we get

$$\ln |f(x)| = x + \ln \left(\frac{2}{e}\right)$$

$$\Rightarrow \ln |f(x)| - \ln \left(\frac{2}{e}\right) = x$$

$$\Rightarrow \ln \left| \frac{ef(x)}{2} \right| = x \quad [\because \ln A - \ln B = \ln \frac{A}{B}]$$

$$\Rightarrow \left| \frac{e}{2} f(x) \right| = e^x \quad [\because \ln a = b \Rightarrow a = e^b, a > 0]$$

$$\Rightarrow |f(x)| = 2e^{x-1} \quad \left[\because \left| \frac{e}{2} f(x) \right| = \frac{e}{2} |f(x)| \right]$$

$$f(x) = 2e^{x-1} \text{ or } -2e^{x-1}$$

Now, $h(x) = f(f(x))$

$$\Rightarrow h'(x) = f'(f(x)) \cdot f'(x)$$

[on differentiating both sides w.r.t. 'x']

$$\Rightarrow h'(1) = f'(f(1)) \cdot f'(1)$$

$$= f'(2) \cdot f'(1) \quad [\because f(1) = 2 \text{ (given)}]$$

$$= 2e^{2-1} \cdot 2e^{1-1} \quad [\because f'(x) = 2e^{x-1} \text{ or } -2e^{x-1}]$$

$$= 4e$$

3. We have, $\frac{dy}{dx} = (x - y)^2$ which is a differential equation of the form

$$\frac{dy}{dx} = f(ax + by + c)$$

Put $x - y = t$

$$\Rightarrow 1 - \frac{dy}{dx} = \frac{dt}{dx} \Rightarrow \frac{dy}{dx} = 1 - \frac{dt}{dx}$$

$$\Rightarrow 1 - \frac{dt}{dx} = t^2 \quad \left[\because \frac{dy}{dx} = (x - y)^2 \right]$$

$$\Rightarrow \frac{dt}{dx} = 1 - t^2 \Rightarrow \int \frac{dt}{1 - t^2} = \int dx$$

[separating the variables]

$$\Rightarrow \frac{1}{2} \log_e \left(\frac{1+t}{1-t} \right) = x + C$$

$$\left[\int \frac{dx}{a^2 - x^2} = \frac{1}{2a} \log_e \left| \frac{a+x}{a-x} \right| + C \right]$$

$$\Rightarrow \frac{1}{2} \log_e \left(\frac{1+x-y}{1-x+y} \right) = x + C \quad [\because t = x - y]$$

Since, $y = 1$ when $x = 1$, therefore

$$\frac{1}{2} \log_e \left(\frac{1+0}{1+0} \right) = 1 + C$$

$$\Rightarrow C = -1 \quad [\because \log 1 = 0]$$

$$\therefore \frac{1}{2} \log_e \left(\frac{1+x-y}{1-x+y} \right) = x - 1$$

$$\Rightarrow -\log_e \left| \frac{1-x+y}{1+x-y} \right| = 2(x-1)$$

[$\because \log \frac{1}{x} = \log x^{-1} = -\log x$]

4. Given, $f(xy) = f(x) \cdot f(y), \forall x, y \in [0, 1]$... (i)

Putting $x = y = 0$ in Eq. (i), we get

$$f(0) = f(0) \cdot f(0)$$

$$\Rightarrow f(0) [f(0) - 1] = 0$$

$$\Rightarrow f(0) = 1 \text{ as } f(0) \neq 0$$

Now, put $y = 0$ in Eq. (i), we get

$$f(0) = f(x) \cdot f(0)$$

$$\Rightarrow f(x) = 1$$

So, $\frac{dy}{dx} = f(x) \Rightarrow \frac{dy}{dx} = 1$

$$\Rightarrow \int dy = \int dx$$

$$\begin{aligned} \Rightarrow & y = x + C \\ \because & y(0) = 1 \\ \therefore & 1 = 0 + C \\ \Rightarrow & C = 1 \\ \therefore & y = x + 1 \\ \text{Now, } & y\left(\frac{1}{4}\right) = \frac{1}{4} + 1 = \frac{5}{4} \text{ and } y\left(\frac{3}{4}\right) = \frac{3}{4} + 1 = \frac{7}{4} \\ \Rightarrow & y\left(\frac{1}{4}\right) + y\left(\frac{3}{4}\right) = \frac{5}{4} + \frac{7}{4} = 3 \end{aligned}$$

5. We have, $(2 + \sin x) \frac{dy}{dx} + (y + 1) \cos x = 0$

$$\Rightarrow \frac{dy}{dx} + \frac{\cos x}{2 + \sin x} y = \frac{-\cos x}{2 + \sin x}$$

which is a linear differential equation.

$$\therefore \text{IF} = e^{\int \frac{\cos x}{2 + \sin x} dx} = e^{\log(2 + \sin x)} = 2 + \sin x$$

\therefore Required solution is given by

$$y \cdot (2 + \sin x) = \int \frac{-\cos x}{2 + \sin x} \cdot (2 + \sin x) dx + C$$

$$\Rightarrow y(2 + \sin x) = -\sin x + C$$

Also, $y(0) = 1$

$$\therefore 1(2 + \sin 0) = -\sin 0 + C$$

$$\Rightarrow C = 2$$

$$\therefore y = \frac{2 - \sin x}{2 + \sin x}$$

$$\Rightarrow y\left(\frac{\pi}{2}\right) = \frac{2 - \sin \frac{\pi}{2}}{2 + \sin \frac{\pi}{2}} = \frac{1}{3}$$

6. $\frac{dy}{dx} = \frac{1}{8\sqrt{x}\sqrt{9 + \sqrt{x}}\sqrt{4 + \sqrt{9 + \sqrt{x}}}}$

$$\Rightarrow y = \sqrt{4 + \sqrt{9 + \sqrt{x}}} + c$$

Now, $y(0) = \sqrt{7} + c$

$$\Rightarrow c = 0$$

$$y(256) = \sqrt{4 + \sqrt{9 + 16}} = \sqrt{4 + 5} = 3$$

7. Here, $\sum_{k=1}^{13} \frac{1}{\sin\left\{\frac{\pi}{4} + \frac{(k-1)\pi}{6}\right\} \sin\left(\frac{\pi}{4} + \frac{k\pi}{6}\right)}$

Converting into differences, by multiplying and dividing by $\sin\left[\left(\frac{\pi}{4} + \frac{k\pi}{6}\right) - \left(\frac{\pi}{4} + \frac{(k-1)\pi}{6}\right)\right]$, i.e.

$$\sin\left(\frac{\pi}{6}\right).$$

$$\therefore \sum_{k=1}^{13} \frac{\sin\left[\left(\frac{\pi}{4} + \frac{k\pi}{6}\right) - \left(\frac{\pi}{4} + \frac{(k-1)\pi}{6}\right)\right]}{\sin \frac{\pi}{6} \left\{ \sin\left\{\frac{\pi}{4} + \frac{(k-1)\pi}{6}\right\} \sin\left(\frac{\pi}{4} + \frac{k\pi}{6}\right) \right\}}$$

$$\begin{aligned} &= 2 \sum_{k=1}^{13} \frac{\left[\sin\left(\frac{\pi}{4} + \frac{k\pi}{6}\right) \cos\left\{\frac{\pi}{4} + \frac{(k-1)\pi}{6}\right\} - \sin\left\{\frac{\pi}{4} + \frac{(k-1)\pi}{6}\right\} \cos\left(\frac{\pi}{4} + \frac{k\pi}{6}\right) \right]}{\sin\left\{\frac{\pi}{4} + \frac{(k-1)\pi}{6}\right\} \sin\left(\frac{\pi}{4} + \frac{k\pi}{6}\right)} \\ &= 2 \sum_{k=1}^{13} \left[\cot\left\{\frac{\pi}{4} + \frac{(k-1)\pi}{6}\right\} - \cot\left(\frac{\pi}{4} + \frac{k\pi}{6}\right) \right] \\ &= 2 \left[\left\{ \cot\left(\frac{\pi}{4}\right) - \cot\left(\frac{\pi}{4} + \frac{\pi}{6}\right) \right\} \right. \\ &\quad \left. + \left\{ \cot\left(\frac{\pi}{4} + \frac{\pi}{6}\right) - \cot\left(\frac{\pi}{4} + \frac{2\pi}{6}\right) \right\} \right. \\ &\quad \left. + \dots + \left\{ \cot\left(\frac{\pi}{4} + 12\frac{\pi}{6}\right) - \cot\left(\frac{\pi}{4} + 13\frac{\pi}{6}\right) \right\} \right] \\ &= 2 \left\{ \cot \frac{\pi}{4} - \cot\left(\frac{\pi}{4} + 13\frac{\pi}{6}\right) \right\} \\ &= 2 \left[1 - \cot\left(\frac{29\pi}{12}\right) \right] = 2 \left[1 - \cot\left(2\pi + \frac{5\pi}{12}\right) \right] \\ &= 2 \left[1 - \cot \frac{5\pi}{12} \right] \quad \left[\because \cot \frac{5\pi}{12} = (2 - \sqrt{3}) \right] \\ &= 2(1 - 2 + \sqrt{3}) \\ &= 2(\sqrt{3} - 1) \end{aligned}$$

8. Given, $\frac{dy}{dx} = \frac{\sqrt{1-y^2}}{y}$

$$\Rightarrow \int \frac{y}{\sqrt{1-y^2}} dy = \int dx$$

$$\Rightarrow -\sqrt{1-y^2} = x + c \Rightarrow (x+c)^2 + y^2 = 1$$

Here, centre $(-c, 0)$ and radius = 1

9. Given, $\frac{dy}{dx} = \frac{-\cos x (y+1)}{2 + \sin x}$

$$\Rightarrow \frac{dy}{y+1} = \frac{-\cos x}{2 + \sin x} dx$$

On integrating both sides

$$\int \frac{dy}{y+1} = - \int \frac{\cos x}{2 + \sin x} dx$$

$$\Rightarrow \log(y+1) = -\log(2 + \sin x) + \log c$$

When $x=0, y=1 \Rightarrow c=4$

$$\Rightarrow y+1 = \frac{4}{2 + \sin x}$$

$$\therefore y\left(\frac{\pi}{2}\right) = \frac{4}{3} - 1$$

$$\Rightarrow y\left(\frac{\pi}{2}\right) = \frac{1}{3}$$

10. Given differential equation is

$$\left(\frac{dy}{dx}\right)^2 - x \frac{dy}{dx} + y = 0 \quad \dots(i)$$

362 Differential Equations

(a) $y=2 \Rightarrow \frac{dy}{dx}=0$

On putting in Eq. (i),

$$0^2 - x(0) + y = 0$$

$\Rightarrow y=0$ which is not satisfied.

(b) $y=2x \Rightarrow \frac{dy}{dx}=2$

On putting in Eq. (i),

$$(2)^2 - x \cdot 2 + y = 0$$

$$\Rightarrow 4 - 2x + y = 0$$

$\Rightarrow y=2x$ which is not satisfied.

(c) $y=2x-4 \Rightarrow \frac{dy}{dx}=2$

On putting in Eq. (i)

$$(2)^2 - x - 2 + y$$

$$4 - 2x + 2x - 4 = 0$$

$$[\because y=2x-4]$$

$y=2x-4$ is satisfied.

(d) $y=2x^2-4$

$$\frac{dy}{dx}=4x$$

On putting in Eq. (i),

$$(4x)^2 - x \cdot 4x + y = 0$$

$\Rightarrow y=0$ which is not satisfied.

11. Given, $y = (c_1 + c_2) \cos(x + c_3) - c_4 e^{x+c_5}$... (i)

$$\Rightarrow y = (c_1 + c_2) \cos(x + c_3) - c_4 e^x \cdot e^{c_5}$$

Now, let $c_1 + c_2 = A, c_3 = B, c_4 e^{c_5} = c$

$$\Rightarrow y = A \cos(x + B) - ce^x$$
 ... (ii)

On differentiating w.r.t. x , we get

$$\frac{dy}{dx} = -A \sin(A + B) - ce^x$$
 ... (iii)

Again, on differentiating w.r.t. x , we get

$$\frac{d^2y}{dx^2} = -A \cos(x + B) - ce^x$$
 ... (iv)

$$\Rightarrow \frac{d^2y}{dx^2} = -y - 2ce^x$$
 ... (v)

$$\Rightarrow \frac{d^2y}{dx^2} + y = -2ce^x$$

Again, on differentiating w.r.t. x , we get

$$\frac{d^3y}{dx^3} + \frac{dy}{dx} = -2ce^x$$
 ... (vi)

$$\Rightarrow \frac{d^3y}{dx^3} + \frac{dy}{dx} = \frac{d^2y}{dx^2} + y$$
 [from Eq. (v)]

which is a differential equation of order 3.

12. Given differential equation

$$f'(x) = \frac{f(x)}{b^2 + x^2}$$

$$\Rightarrow \int \frac{f'(x)}{f(x)} dx = \int \frac{dx}{b^2 + x^2}$$

$$\Rightarrow \log_e |f(x)| = \frac{1}{b} \tan^{-1}\left(\frac{x}{b}\right) + c$$

$$\because f(0) = 1, \text{ so } c = 0$$

$$\therefore |f(x)| = e^{\frac{1}{b} \tan^{-1}\left(\frac{x}{b}\right)}$$

$$\Rightarrow f(x) = e^{\frac{1}{b} \tan^{-1}\left(\frac{x}{b}\right)} \text{ or } -e^{\frac{1}{b} \tan^{-1}\left(\frac{x}{b}\right)}$$

$$\because f(0) = 1$$

$$\therefore f(x) = e^{\frac{1}{b} \tan^{-1}\left(\frac{x}{b}\right)}$$

and
$$f'(x) = \frac{1}{b^2} \frac{e^{\frac{1}{b} \tan^{-1}\left(\frac{x}{b}\right)}}{1 + \left(\frac{x}{b}\right)^2}$$

$$= \frac{e^{\frac{1}{b} \tan^{-1}\left(\frac{x}{b}\right)}}{b^2 + x^2}$$

$\therefore f'(x) > 0 \forall x \in R$ and $b \in R_0$.

Therefore, $f(x)$ is an increasing function $\forall b \in R_0$.

and $f(x) f(-x) = e^{\frac{1}{b} \tan^{-1}\left(\frac{x}{b}\right)} \cdot e^{-\frac{1}{b} \tan^{-1}\left(\frac{x}{b}\right)} = 1$

13. We have,

$$f(x) = 1 - 2x + \int_0^x e^{x-t} f(t) dt$$

On multiplying e^{-x} both sides, we get

$$e^{-x} f(x) = e^{-x} - 2xe^{-x} + \int_0^x e^{-t} f(t) dt$$

On differentiating both side w.r.t. x , we get

$$e^{-x} f'(x) - e^{-x} f(x) = -e^{-x} - 2e^{-x} + 2xe^{-x} + e^{-x} f(x)$$

$$\Rightarrow f'(x) - 2f(x) = 2x - 3$$
 [dividing both sides by e^{-x}]

Let $f(x) = y \Rightarrow f'(x) = \frac{dy}{dx}$

$$\therefore \frac{dy}{dx} - 2y = 2x - 3$$

which is linear differential equation of the form $\frac{dy}{dx} + Py = Q$. Here, $P = -2$ and $Q = 2x - 3$.

Now, IF = $e^{\int P dx} = e^{\int -2 dx} = e^{-2x}$

\therefore Solution of the given differential equation is

$$y \cdot e^{-2x} = \int (2x - 3) e^{-2x} dx + C$$

$$y \cdot e^{-2x} = \frac{-(2x - 3) \cdot e^{-2x}}{2} + 2 \int \frac{e^{-2x}}{2} dx + C$$

[by using integration by parts]

$$\Rightarrow y \cdot e^{-2x} = \frac{-(2x - 3) e^{-2x}}{2} - \frac{e^{-2x}}{2} + C$$

$$\Rightarrow y = (1 - x) + Ce^{2x}$$

On putting $x=0$ and $y=1$, we get

$$1 = 1 + C$$

$$\Rightarrow C = 0$$

$$\therefore y = 1 - x$$

$y = 1 - x$ passes through $(2, -1)$

Now, area of region bounded by curve $y = \sqrt{1-x^2}$ and $y = 1-x$ is shown as

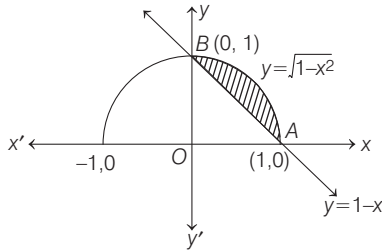

∴ Area of shaded region
 = Area of 1st quadrant of a circle - Area of ΔOAB

$$= \frac{\pi}{4}(1)^2 - \frac{1}{2} \times 1 \times 1 = \frac{\pi}{4} - \frac{1}{2} = \frac{\pi-2}{4}$$

Hence, options b and c are correct.

14. Here, $(1 + e^x)y' + ye^x = 1$

$$\Rightarrow \frac{dy}{dx} + e^x \cdot \frac{dy}{dx} + ye^x = 1$$

$$\Rightarrow dy + e^x dy + ye^x dx = dx$$

$$\Rightarrow dy + d(e^x y) = dx$$

On integrating both sides, we get

$$y + e^x y = x + C$$

Given, $y(0) = 2$

$$\Rightarrow 2 + e^0 \cdot 2 = 0 + C$$

$$\Rightarrow C = 4$$

$$\therefore y(1 + e^x) = x + 4$$

$$\Rightarrow y = \frac{x+4}{1+e^x}$$

Now at $x = -4$, $y = \frac{-4+4}{1+e^{-4}} = 0$

∴ $y(-4) = 0$... (i)

For critical points, $\frac{dy}{dx} = 0$

i.e.
$$\frac{dy}{dx} = \frac{(1+e^x) \cdot 1 - (x+4)e^x}{(1+e^x)^2} = 0$$

$$\Rightarrow e^x(x+3) - 1 = 0$$

or
$$e^{-x} = (x+3)$$

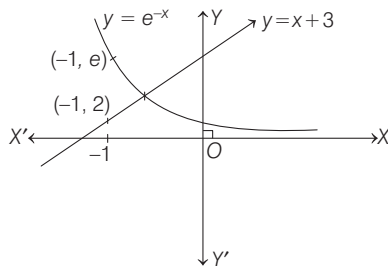

Clearly, the intersection point lies between $(-1, 0)$.
 ∴ $y(x)$ has a critical point in the interval $(-1, 0)$.

15. Since, centre lies on $y = x$

∴ Equation of circle is

$$x^2 + y^2 - 2ax - 2ay + c = 0$$

On differentiating, we get

$$2x + 2yy' - 2a - 2ay' = 0$$

$$\Rightarrow x + yy' - a - ay' = 0 \Rightarrow a = \frac{x + yy'}{1 + y'}$$

Again differentiating, we get

$$0 = \frac{(1 + y')[1 + yy' + (y')^2] - (x + yy') \cdot (y')'}{(1 + y')^2}$$

$$\Rightarrow (1 + y') [1 + (y')^2 + yy''] - (x + yy') (y'') = 0$$

$$\Rightarrow 1 + y' [(y')^2 + y' + 1] + y''(y - x) = 0$$

On comparing with $Py'' + Qy' + 1 = 0$, we get

$$P = y - x \text{ and } Q = (y')^2 + y' + 1$$

16. Given, $y^2 = 2c(x + \sqrt{c})$... (i)

On differentiating w.r.t. x , we get

$$2y \frac{dy}{dx} = 2c \Rightarrow c = y \frac{dy}{dx}$$

On putting this value of c in Eq. (i), we get

$$y^2 = 2y \frac{dy}{dx} \left(x + \sqrt{y \frac{dy}{dx}} \right)$$

$$\Rightarrow y = 2 \frac{dy}{dx} \cdot x + 2y^{1/2} \left(\frac{dy}{dx} \right)^{3/2}$$

$$\Rightarrow y - 2x \frac{dy}{dx} = 2\sqrt{y} \left(\frac{dy}{dx} \right)^{3/2}$$

$$\Rightarrow \left(y - 2x \frac{dy}{dx} \right)^2 = 4y \left(\frac{dy}{dx} \right)^3$$

Therefore, order of this differential equation is 1 and degree is 3.

17. We have,

$$\frac{dy}{dx} = (2 + 5y)(5y - 2)$$

$$\Rightarrow \frac{dy}{25y^2 - 4} = dx \Rightarrow \frac{1}{25} \left(\frac{dy}{y^2 - \frac{4}{25}} \right) = dx$$

On integrating both sides, we get

$$\frac{1}{25} \int \frac{dy}{y^2 - \left(\frac{2}{5}\right)^2} = \int dx$$

$$\Rightarrow \frac{1}{25} \times \frac{1}{2 \times \frac{2}{5}} \log \left| \frac{y - 2/5}{y + 2/5} \right| = x + C$$

$$\Rightarrow \log \left| \frac{5y - 2}{5y + 2} \right| = 20(x + C)$$

$$\Rightarrow \left| \frac{5y - 2}{5y + 2} \right| = Ae^{20x} \quad [\because e^{20C} = A]$$

364 Differential Equations

when $x=0 \Rightarrow y=0$, then $A=1$

$$\therefore \left| \frac{5y-2}{5y+2} \right| = e^{20x}$$

$$\lim_{x \rightarrow -\infty} \left| \frac{5f(x)-2}{5f(x)+2} \right| = \lim_{x \rightarrow -\infty} e^{20x}$$

$$\Rightarrow \lim_{n \rightarrow -\infty} \left| \frac{5f(x)-2}{5f(x)+2} \right| = 0$$

$$\Rightarrow \lim_{n \rightarrow -\infty} 5f(x)-2=0$$

$$\Rightarrow \lim_{n \rightarrow -\infty} f(x) = \frac{2}{5} = 0.4$$

18. From given integral equation, $f(0) = 0$.

Also, differentiating the given integral equation w.r.t. x

$$f'(x) = f(x)$$

If $f(x) \neq 0$

$$\Rightarrow \frac{f'(x)}{f(x)} = 1 \Rightarrow \log f(x) = x + c$$

$$\Rightarrow f(x) = e^c e^x$$

$$\therefore f(0) = 0 \Rightarrow e^c = 0, \text{ a contradiction}$$

$$\therefore f(x) = 0, \forall x \in R$$

$$\Rightarrow f(\ln 5) = 0$$

Alternate Solution

$$\text{Given, } f(x) = \int_0^x f(t) dt$$

$$\Rightarrow f(0) = 0 \text{ and } f'(x) = f(x)$$

If $f(x) \neq 0$

$$\Rightarrow \frac{f'(x)}{f(x)} = 1 \Rightarrow \ln f(x) = x + c$$

$$\Rightarrow f(x) = e^c \cdot e^x$$

$$\therefore f(0) = 0$$

$$\Rightarrow e^c = 0, \text{ a contradiction}$$

$$\therefore f(x) = 0, \forall x \in R \Rightarrow f(\ln 5) = 0$$

19. Given, $\frac{dy}{dx} = \frac{y\sqrt{y^2-1}}{x\sqrt{x^2-1}}$

$$\int \frac{dy}{y\sqrt{y^2-1}} = \int \frac{dx}{x\sqrt{x^2-1}}$$

$$\Rightarrow \sec^{-1} y = \sec^{-1} x + c$$

$$\text{At } x=2, y = \frac{2}{\sqrt{3}}; \frac{\pi}{6} = \frac{\pi}{3} + c \Rightarrow c = -\frac{\pi}{6}$$

$$\text{Now, } y = \sec \left(\sec^{-1} x - \frac{\pi}{6} \right) = \cos \left[\cos^{-1} \frac{1}{x} - \cos^{-1} \frac{\sqrt{3}}{2} \right]$$

$$= \cos \left[\cos^{-1} \left(\frac{\sqrt{3}}{2x} + \sqrt{1 - \frac{1}{x^2}} \sqrt{1 - \frac{3}{4}} \right) \right]$$

$$y = \frac{\sqrt{3}}{2x} + \frac{1}{2} \sqrt{1 - \frac{1}{x^2}}$$

20. Given, $P(1) = 0$ and $\frac{dP(x)}{dx} - P(x) > 0, \forall x \geq 1$... (i)

On multiplying Eq. (i) by e^{-x} , we get

$$e^{-x} \cdot \frac{d}{dx} P(x) \cdot \frac{d}{dx} e^{-x} > 0$$

$$\Rightarrow \frac{d}{dx} (P(x) \cdot e^{-x}) > 0$$

$\Rightarrow P(x) \cdot e^{-x}$ is an increasing function.

$$\Rightarrow P(x) \cdot e^{-x} > P(1) \cdot e^{-1}, \forall x \geq 1$$

$$\Rightarrow P(x) > 0, \forall x > 1 \quad [\because P(1) = 0 \text{ and } e^{-x} > 0]$$

21. Equation of tangent to the curve $y = f(x)$ at point

$$A(x, y) \text{ is } Y - y = \frac{dy}{dx} (X - x)$$

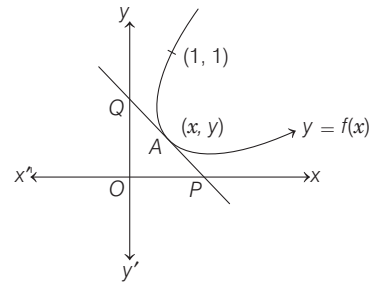

$$\text{whose, x-intercept } \left(x - y \cdot \frac{dx}{dy}, 0 \right)$$

$$\text{y-intercept } \left(0, y - x \frac{dy}{dx} \right)$$

Given, $\Delta OPQ = 2$

$$\Rightarrow \frac{1}{2} \cdot \left(x - y \frac{dx}{dy} \right) \left(y - x \frac{dy}{dx} \right) = 2$$

$$\Rightarrow \left(x - y \frac{1}{p} \right) (y - xp) = 4, \text{ where } p = \frac{dy}{dx}$$

$$\Rightarrow p^2 x^2 - 2pxy + 4p + y^2 = 0$$

$$\Rightarrow (y - px)^2 + 4p = 0$$

$$\therefore y - px = 2\sqrt{-p}$$

$$\Rightarrow y = px + 2\sqrt{-p} \quad \dots (i)$$

On differentiating w.r.t. x , we get

$$p = p + \frac{dp}{dx} \cdot x + 2 \cdot \left(\frac{1}{2} \right) (-p)^{-1/2} \cdot (-1) \frac{dp}{dx}$$

$$\Rightarrow \frac{dp}{dx} \{ x - (-p)^{-1/2} \} = 0$$

$$\Rightarrow \frac{dp}{dx} = 0 \text{ or } x = (-p)^{-1/2}$$

$$\text{If } \frac{dp}{dx} = 0 \Rightarrow p = c$$

On putting this value in Eq. (i), we get $y = cx + 2\sqrt{-c}$

This curve passes through $(1, 1)$.

$$\Rightarrow 1 = c + 2\sqrt{-c}$$

$$\Rightarrow c = -1$$

$$\therefore y = -x + 2$$

$$\Rightarrow \begin{aligned} x + y &= 2 \\ \text{Again, if } x &= (-p)^{-1/2} \\ \Rightarrow -p &= \frac{1}{x^2} \text{ putting in Eq. (i)} \\ y &= \frac{-x}{x^2} + 2 \cdot \frac{1}{x} \Rightarrow xy = 1 \end{aligned}$$

Thus, the two curves are $xy = 1$ and $x + y = 2$.

22. Let $\phi(x) = e^{-x}f(x)$

Here, $\phi'(x) < 0, x \in \left(0, \frac{1}{4}\right)$

and $\phi'(x) > 0, x \in \left(\frac{1}{4}, 1\right)$

$$\Rightarrow e^{-x}f'(x) - e^{-x}f(x) < 0, x \in \left(0, \frac{1}{4}\right)$$

$$\Rightarrow f'(x) < f(x), 0 < x < \frac{1}{4}$$

23. Here, $f''(x) - 2f'(x) + f(x) \geq e^x$

$$\Rightarrow f''(x)e^{-x} - f'(x)e^{-x} - f'(x)e^{-x} + f(x)e^{-x} \geq 0$$

$$\Rightarrow \frac{d}{dx}\{f'(x)e^{-x}\} - \frac{d}{dx}\{f(x)e^{-x}\} \geq 1$$

$$\Rightarrow \frac{d}{dx}\{f'(x)e^{-x} - f(x)e^{-x}\} \geq 1$$

$$\Rightarrow \frac{d^2}{dx^2}\{e^{-x}f(x)\} \geq 1, \forall x \in [0, 1]$$

$\therefore \phi(x) = e^{-x}f(x)$ is concave function.

$$f(0) = f(1) = 0$$

$$\Rightarrow \phi(0) = 0 = f(1)$$

$$\Rightarrow \phi(x) < 0$$

$$\Rightarrow e^{-x}f(x) < 0$$

$$\therefore f(x) < 0$$

24. Here, $f(x) = (1-x)^2 \cdot \sin^2 x + x^2 \geq 0, \forall x$

and $g(x) = \int_1^x \left(\frac{2(t-1)}{t+1} - \log t \right) f(t) dt$

$$\Rightarrow g'(x) = \left\{ \frac{2(x-1)}{(x+1)} - \log x \right\} \cdot \underbrace{f(x)}_{+ve} \quad \dots(i)$$

For $g'(x)$ to be increasing or decreasing.

Let $\phi(x) = \frac{2(x-1)}{x+1} - \log x$

$$\phi'(x) = \frac{4}{(x+1)^2} - \frac{1}{x} = \frac{-(x-1)}{x(x+1)^2}$$

$$\phi'(x) < 0, \forall x > 1$$

$$\Rightarrow \phi(x) < \phi(1)$$

$$\Rightarrow \phi(x) < 0 \quad \dots(ii)$$

From Eqs. (i) and (ii), $g'(x) < 0, x \in (1, \infty)$

$\therefore g(x)$ is decreasing on $x \in (1, \infty)$.

25. Here, $f(x) + 2x = (1-x)^2 \cdot \sin^2 x + x^2 + 2x \quad \dots(i)$

where, I: $f(x) + 2x = 2(1+x)^2 \quad \dots(ii)$

$$\therefore 2(1+x^2) = (1-x)^2 \sin^2 x + x^2 + 2x$$

$$\Rightarrow (1-x)^2 \sin^2 x = x^2 - 2x + 2$$

$$\Rightarrow (1-x)^2 \sin^2 x = (1-x)^2 + 1$$

$$\Rightarrow (1-x)^2 \cos^2 x = -1$$

which is never possible.

\therefore I is false.

Again, let $h(x) = 2f(x) + 1 - 2x(1+x)$

where, $h(0) = 2f(0) + 1 - 0 = 1$

$$h(1) = 2(1) + 1 - 4 = -3 \text{ as } [h(0)h(1) < 0]$$

$\Rightarrow h(x)$ must have a solution.

\therefore II is true.

Topic 2 Linear Differential Equation and Exact Differential Equation

1. Given differential equation is

$$(y^2 - x^3) dx - xy dy = 0, (x \neq 0)$$

$$\Rightarrow xy \frac{dy}{dx} - y^2 = -x^3$$

Now, put $y^2 = t \Rightarrow 2y \frac{dy}{dx} = \frac{dt}{dx} \Rightarrow y \frac{dy}{dx} = \frac{1}{2} \frac{dt}{dx}$

$$\therefore \frac{x}{2} \frac{dt}{dx} - t = -x^3 \Rightarrow \frac{dt}{dx} - \frac{2}{x}t = -2x^2$$

which is the linear differential equation of the form

$$\frac{dt}{dx} + Pt = Q.$$

Here, $P = -\frac{2}{x}$ and $Q = -2x^2$.

Now, $IF = e^{-\int \frac{2}{x} dx} = \frac{1}{x^2}$

\therefore Solution of the linear differential equation is

(IF) $t = \int Q(IF)dx + \lambda$ [where λ is integrating constant]

$$\therefore t \left(\frac{1}{x^2} \right) = -2 \int \left(x^2 \times \frac{1}{x^2} \right) dx + \lambda$$

$$\Rightarrow \frac{t}{x^2} = -2x + \lambda$$

$$\Rightarrow \frac{y^2}{x^2} + 2x = \lambda \quad [\because t = y^2]$$

$$\Rightarrow y^2 + 2x^3 - \lambda x^2 = 0$$

$$\text{or } y^2 + 2x^3 + Cx^2 = 0 \quad [\text{let } C = -\lambda]$$

2. Given differential equation is

$$y^2 dx + \left(x - \frac{1}{y} \right) dy = 0$$

$$\Rightarrow \frac{dx}{dy} + \frac{1}{y^2}x = \frac{1}{y^3}, \text{ which is the linear differential}$$

equation of the form $\frac{dx}{dy} + Px = Q.$

366 Differential Equations

Here, $P = \frac{1}{y^2}$ and $Q = \frac{1}{y^3}$

Now, $IF = e^{\int \frac{1}{y^2} dy} = e^{-\frac{1}{y}}$

∴ The solution of linear differential equation is

$$x \cdot (IF) \int Q(IF)dy + C$$

$$\Rightarrow x e^{-1/y} = \int \frac{1}{y^3} e^{-1/y} dy + C$$

$$\therefore x e^{-1/y} = \int (-t) e^t dt + C \quad [\because \text{let } -\frac{1}{y} = t \Rightarrow +\frac{1}{y^2} dy = dt]$$

$$= -te^t + \int e^t dt + C \quad [\text{integration by parts}]$$

$$= -te^t + e^t + C$$

$$\Rightarrow x e^{-1/y} = \frac{1}{y} e^{-1/y} + e^{-1/y} + C \quad \dots (i)$$

Now, at $y = 1$, the value of $x = 1$, so

$$1 \cdot e^{-1} = e^{-1} + e^{-1} + C \Rightarrow C = -\frac{1}{e}$$

On putting the value of C , in Eq. (i), we get

$$x = \frac{1}{y} + 1 - \frac{e^{1/y}}{e}$$

So, at $y = 2$, the value of $x = \frac{1}{2} + 1 - \frac{e^{1/2}}{e} = \frac{3}{2} - \frac{1}{\sqrt{e}}$

3. Given differential equation is

$$\frac{dy}{dx} + y \tan x = 2x + x^2 \tan x, \text{ which is linear differential}$$

$$\text{equation in the form of } \frac{dy}{dx} + Py = Q.$$

Here, $P = \tan x$ and $Q = 2x + x^2 \tan x$

$$\therefore IF = e^{\int \tan x dx} = e^{\log_e(\sec x)} = \sec x$$

Now, solution of linear differential equation is given as

$$y \times IF = \int (Q \times IF) dx + C$$

$$\therefore y(\sec x) = \int (2x + x^2 \tan x) \sec x dx + C$$

$$= \int (2x \sec x) dx + \int x^2 \sec x \tan x dx + C$$

$$\therefore \int x^2 \sec x \tan x dx = x^2 \sec x - \int (2x \sec x) dx$$

Therefore, solution is

$$y \sec x = 2 \int x \sec x dx + x^2 \sec x - 2 \int x \sec x dx + C$$

$$\Rightarrow y \sec x = x^2 \sec x + C \quad \dots (i)$$

$$\therefore y(0) = 1 \Rightarrow 1(1) = 0(1) + C \Rightarrow C = 1$$

Now, $y = x^2 + \cos x$ [from Eq. (i)]

and $y' = 2x - \sin x$

According to options,

$$y' \left(\frac{\pi}{4} \right) - y' \left(-\frac{\pi}{4} \right) = \left(2 \left(\frac{\pi}{4} \right) - \frac{1}{\sqrt{2}} \right) - \left(2 \left(-\frac{\pi}{4} \right) + \frac{1}{\sqrt{2}} \right) = \pi - \sqrt{2}$$

$$\text{and } y' \left(\frac{\pi}{4} \right) + y' \left(-\frac{\pi}{4} \right) = \left(2 \left(\frac{\pi}{4} \right) - \frac{1}{\sqrt{2}} \right) + \left(2 \left(-\frac{\pi}{4} \right) + \frac{1}{\sqrt{2}} \right) = 0$$

$$\text{and } y \left(\frac{\pi}{4} \right) + y \left(-\frac{\pi}{4} \right) = \frac{\pi^2}{16} + \frac{1}{\sqrt{2}} + \frac{\pi^2}{16} + \frac{1}{\sqrt{2}} = \frac{\pi^2}{4} + \sqrt{2}$$

$$\text{and } y \left(\frac{\pi}{4} \right) - y \left(-\frac{\pi}{4} \right) = \frac{\pi^2}{16} + \frac{1}{\sqrt{2}} - \frac{\pi^2}{16} - \frac{1}{\sqrt{2}} = 0$$

4. Given differential equation

$$\frac{dy}{dx} = (\tan x - y) \sec^2 x$$

$$\Rightarrow \frac{dy}{dx} + (\sec^2 x)y = \sec^2 x \tan x,$$

which is linear differential equation of the form

$$\frac{dy}{dx} + Py = Q,$$

where $P = \sec^2 x$ and $Q = \sec^2 x \tan x$

$$IF = e^{\int \sec^2 x dx} = e^{\tan x}$$

So, solution of given differential equation is

$$y \times IF = \int (Q \times IF) dx + C$$

$$y(e^{\tan x}) = \int e^{\tan x} \cdot \sec^2 x \tan x dx + C$$

Let

$$\tan x = t \Rightarrow \sec^2 x dx = dt$$

$$ye^{\tan x} = \int e^t \cdot t dt + C = te^t - \int e^t dt + C$$

[using integration by parts method]

$$= e^t(t-1) + C$$

$$\Rightarrow y \cdot e^{\tan x} = e^{\tan x}(\tan x - 1) + C \quad [\because t = \tan x]$$

$$\therefore y(0) = 0$$

$$\Rightarrow 0 = 1(0-1) + C \Rightarrow C = 1$$

$$\therefore y \cdot e^{\tan x} = e^{\tan x}(\tan x - 1) + 1$$

Now, at $x = -\frac{\pi}{4}$

$$ye^{-1} = e^{-1}(-1-1) + 1$$

$$\Rightarrow ye^{-1} = -2e^{-1} + 1 \Rightarrow y = e - 2$$

5. **Key Idea** (i) First convert the given differential equation into linear differential equation of the form $\frac{dy}{dx} + Py = Q$

(ii) Find IF

(iii) Apply formula, $y(IF) = \int Q(IF) dx + C$

Given differential equation

$$\cos x \frac{dy}{dx} - (\sin x)y = 6x$$

$$\Rightarrow \frac{dy}{dx} - (\tan x)y = \frac{6x}{\cos x}, \text{ which is the linear}$$

differential equation of the form

$$\frac{dy}{dx} + Px = Q,$$

where $P = -\tan x$ and $Q = \frac{6x}{\cos x}$

So, $IF = e^{-\int \tan x dx} = e^{-\log(\sec x)} = \cos x$

∴ Required solution of differential equation is

$$y(\cos x) = \int (6x) \frac{\cos x}{\cos x} dx + C = 6 \frac{x^2}{2} + C = 3x^2 + C$$

Given, $y\left(\frac{\pi}{3}\right) = 0$

So, $0 = 3\left(\frac{\pi}{3}\right)^2 + C \Rightarrow C = -\frac{\pi^2}{3}$

$\therefore y(\cos x) = 3x^2 - \frac{\pi^2}{3}$

Now, at $x = \frac{\pi}{6}$

$$y\left(\frac{\sqrt{3}}{2}\right) = 3\frac{\pi^2}{36} - \frac{\pi^2}{3} = -\frac{\pi^2}{4} \Rightarrow y = -\frac{\pi^2}{2\sqrt{3}}$$

6. Given differential equation is

$$x \frac{dy}{dx} + 2y = x^2, (x \neq 0)$$

$$\Rightarrow \frac{dy}{dx} + \left(\frac{2}{x}\right)y = x,$$

which is a linear differential equation of the form

$$\frac{dy}{dx} + Py = Q$$

Here, $P = \frac{2}{x}$ and $Q = x$

$$\therefore \text{IF} = e^{\int \frac{2}{x} dx} = e^{2 \log x} = x^2$$

Since, solution of the given differential equation is

$$y \times \text{IF} = \int (Q \times \text{IF}) dx + C$$

$$\therefore y(x^2) = \int (x \times x^2) dx + C \Rightarrow yx^2 = \frac{x^4}{4} + C$$

$$\because y(1) = 1, \text{ so } 1 = \frac{1}{4} + C \Rightarrow C = \frac{3}{4}$$

$$\therefore yx^2 = \frac{x^4}{4} + \frac{3}{4} \Rightarrow y = \frac{x^2}{4} + \frac{3}{4x^2}$$

7. Given differential equation is

$$(x^2 + 1)^2 \frac{dy}{dx} + 2x(x^2 + 1)y = 1$$

$$\Rightarrow \frac{dy}{dx} + \left(\frac{2x}{1+x^2}\right)y = \frac{1}{(1+x^2)^2}$$

[dividing each term by $(1+x^2)^2$]
... (i)

This is a linear differential equation of the form

$$\frac{dy}{dx} + P \cdot y = Q$$

Here, $P = \frac{2x}{(1+x^2)}$ and $Q = \frac{1}{(1+x^2)^2}$

$$\therefore \text{Integrating Factor (IF)} = e^{\int \frac{2x}{1+x^2} dx} = e^{\ln(1+x^2)} = (1+x^2)$$

and required solution of differential Eq. (i) is given by

$$y \cdot (\text{IF}) = \int Q(\text{IF}) dx + C$$

$$\Rightarrow y(1+x^2) = \int \frac{1}{(1+x^2)^2} (1+x^2) dx + C$$

$$\Rightarrow y(1+x^2) = \int \frac{dx}{1+x^2} + C$$

$$\Rightarrow y(1+x^2) = \tan^{-1}(x) + C$$

$$\because y(0) = 0$$

$$\therefore C = 0$$

$$\therefore y(1+x^2) = \tan^{-1} x \quad [\because C = 0]$$

$$\Rightarrow y = \frac{\tan^{-1} x}{1+x^2}$$

$$\Rightarrow \sqrt{a}y = \sqrt{a} \left(\frac{\tan^{-1} x}{1+x^2} \right)$$

[multiplying both sides by \sqrt{a}]

Now, at $x = 1$

$$\sqrt{a}y(1) = \sqrt{a} \left(\frac{\tan^{-1}(1)}{1+1} \right) = \sqrt{a} \frac{\pi}{4} = \frac{\sqrt{a}\pi}{8} = \frac{\pi}{32} \text{ (given)}$$

$$\therefore \sqrt{a} = \frac{1}{4} \Rightarrow a = \frac{1}{16}$$

8. We know that, slope of the tangent at any point (x, y) on the curve is

$$\frac{dy}{dx} = \frac{x^2 - 2y}{x} \quad \text{(given)}$$

$$\Rightarrow \frac{dy}{dx} + \frac{2}{x}y = x \quad \dots \text{(i)}$$

which is a linear differential equation of the form

$$\frac{dy}{dx} + P(x) \cdot y = Q(x),$$

where $P(x) = \frac{2}{x}$ and $Q(x) = x$

Now, integrating factor

$$\begin{aligned} (\text{IF}) &= e^{\int P(x) dx} = e^{\int \frac{2}{x} dx} = e^{2 \log_e x} \\ &= e^{\log_e x^2} \quad [\because m \log a = \log a^m] \\ &= x^2 \quad [\because e^{\log_e f(x)} = f(x)] \end{aligned}$$

and the solution of differential Eq. (i) is

$$y(\text{IF}) = \int Q(x)(\text{IF}) dx + C \Rightarrow y(x^2) = \int x \cdot x^2 dx + C$$

$$\Rightarrow yx^2 = \frac{x^4}{4} + C \quad \dots \text{(ii)}$$

\therefore The curve (ii) passes through the point $(1, -2)$, therefore

$$-2 = \frac{1}{4} + C \Rightarrow C = -\frac{9}{4}$$

\therefore Equation of required curve is $4yx^2 = x^4 - 9$.

Now, checking all the option, we get only $(\sqrt{3}, 0)$ satisfy the above equation.

9. Given differential equation is

$$x \frac{dy}{dx} + y = x \log_e x, (x > 1)$$

$$\Rightarrow \frac{dy}{dx} + \frac{1}{x}y = \log_e x \quad \dots \text{(i)}$$

368 Differential Equations

Which is a linear differential equation.

So, if $y = e^{\int \frac{1}{x} dx} = e^{\log_e x} = x$

Now, solution of differential Eq. (i), is

$$y \times x = \int (\log_e x) x dx + C$$

$$\Rightarrow yx = \frac{x^2}{2} \log_e x - \int \frac{x^2}{2} \times \frac{1}{x} dx + C$$

[using integration by parts]

$$\Rightarrow yx = \frac{x^2}{2} \log_e x - \frac{x^2}{4} + C \quad \dots(\text{ii})$$

Given that, $2y(2) = \log_e 4 - 1 \quad \dots(\text{iii})$

On substituting, $x = 2$, in Eq. (ii), we get

$$2y(2) = \frac{4}{2} \log_e 2 - \frac{4}{4} + C,$$

[where, $y(2)$ represents value of y at $x = 2$]

$$\Rightarrow 2y(2) = \log_e 4 - 1 + C \quad \dots(\text{iv})$$

[$\because m \log a = \log a^m$]

From Eqs. (iii) and (iv), we get

$$C = 0$$

So, required solution is

$$yx = \frac{x^2}{2} \log_e x - \frac{x^2}{4}$$

Now, at $x = e$, $ey(e) = \frac{e^2}{2} \log_e e - \frac{e^2}{4}$

[where, $y(e)$ represents value of y at $x = e$]

$$\Rightarrow y(e) = \frac{e}{4} \quad [\because \log_e e = 1].$$

10. We have, $\frac{dy}{dx} + \left(\frac{2x+1}{x}\right)y = e^{-2x}$

which is of the form $\frac{dy}{dx} + Py = Q$, where

$$P = \frac{2x+1}{x} \text{ and } Q = e^{-2x}$$

$$\begin{aligned} \text{Now, IF} &= e^{\int P dx} = e^{\int \left(\frac{1+2x}{x}\right) dx} = e^{\int \left(\frac{1}{x} + 2\right) dx} \\ &= e^{\ln x + 2x} = e^{\ln x} \cdot e^{2x} = x \cdot e^{2x} \end{aligned}$$

and the solution of the given equation is

$$y \cdot (\text{IF}) = \int (\text{IF}) Q dx + C$$

$$\begin{aligned} \Rightarrow y(xe^{2x}) &= \int (xe^{2x} \cdot e^{-2x}) dx + C \\ &= \int x dx + C = \frac{x^2}{2} + C \quad \dots (\text{i}) \end{aligned}$$

Since, $y = \frac{1}{2} e^{-2}$ when $x = 1$

$$\therefore \frac{1}{2} e^{-2} \cdot e^2 = \frac{1}{2} + C \Rightarrow C = 0 \text{ (using Eq. (i))}$$

$$\therefore y(xe^{2x}) = \frac{x^2}{2} \Rightarrow y = \frac{x}{2} e^{-2x}$$

$$\text{Now, } \frac{dy}{dx} = \frac{1}{2} e^{-2x} + \frac{x}{2} e^{-2x} (-2) = e^{-2x} \left\{ \frac{1}{2} - x \right\} < 0,$$

if $\frac{1}{2} < x < 1$ [by using product rule of derivative]

$$\begin{aligned} \text{and } y(\log_e 2) &= \frac{\log_e 2}{2} e^{-2 \log_e 2} = \frac{1}{2} \log_e 2 e^{\log_e 2^{-2}} \\ &= \frac{1}{2} \cdot \log_e 2 \cdot 2^{-2} = \frac{1}{8} \log_e 2 \end{aligned}$$

11. Given, $f'(x) = 7 - \frac{3}{4} \frac{f(x)}{x}$, ($x > 0$)

On putting $f(x) = y$ and $f'(x) = \frac{dy}{dx}$, then we get

$$\frac{dy}{dx} = 7 - \frac{3}{4} \frac{y}{x}$$

$$\Rightarrow \frac{dy}{dx} + \frac{3}{4x} y = 7 \quad \dots(\text{i})$$

which is a linear differential equation of the form $\frac{dy}{dx} + Py = Q$, where $P = \frac{3}{4x}$ and $Q = 7$.

Now, integrating factor (IF) = $e^{\int \frac{3}{4x} dx}$

$$= e^{\frac{3}{4} \log x} = e^{\log x^{3/4}} = x^{3/4}$$

and solution of differential Eq. (i) is given by

$$y(\text{IF}) = \int (Q \cdot (\text{IF})) dx + C$$

$$yx^{3/4} = \int 7x^{3/4} dx + C$$

$$\Rightarrow yx^{3/4} = 7 \frac{x^{3/4+1}}{3/4+1} + C$$

$$\Rightarrow yx^{3/4} = 4x^{3/4} + C$$

$$\Rightarrow y = 4x + Cx^{-3/4}$$

So, $y = f(x) = 4x + C \cdot x^{-3/4}$

$$\text{Now, } f\left(\frac{1}{x}\right) = \frac{4}{x} + C \cdot x^{3/4}$$

$$\begin{aligned} \therefore \lim_{x \rightarrow 0^+} x f\left(\frac{1}{x}\right) &= \lim_{x \rightarrow 0^+} x \left(\frac{4}{x} + Cx^{3/4} \right) \\ &= \lim_{x \rightarrow 0^+} (4 + Cx^{7/4}) = 4 \end{aligned}$$

12. Given, differential equation is

$$\frac{dy}{dx} + \left(\frac{3}{\cos^2 x}\right)y = \frac{1}{\cos^2 x}$$

which is a linear differential equation of the form $\frac{dy}{dx} + Py = Q$, where $P = \frac{3}{\cos^2 x}$ and

$$Q = \frac{1}{\cos^2 x}$$

Now, Integrating factor

$$\text{IF} = e^{\int \frac{3}{\cos^2 x} dx} = e^{3 \sec^2 x} = e^{3 \tan x} \text{ and the solution of}$$

differential equation is given by

$$y(\text{IF}) = \int (Q \cdot (\text{IF})) dx$$

$$\Rightarrow e^{3 \tan x} \cdot y = \int e^{3 \tan x} \sec^2 x dx \quad \dots (\text{i})$$

$$\text{Let } I = \int e^{3 \tan x} \sec^2 x dx$$

Put $3 \tan x = t$
 $\Rightarrow 3 \sec^2 x dx = dt$
 $\therefore I = \int \frac{e^t}{3} dt = \frac{e^t}{3} + C = \frac{e^{3 \tan x}}{3} + C$

From Eq. (i)
 $e^{3 \tan x} \cdot y = \frac{e^{3 \tan x}}{3} + C$

It is given that when,
 $x = \frac{\pi}{4}, y \text{ is } \frac{4}{3}$

$\Rightarrow e^3 \frac{4}{3} = \frac{e^3}{3} + C$

$\Rightarrow C = e^3$

Thus, $e^{3 \tan x} y = \frac{e^{3 \tan x}}{3} + e^3$

Now, when $x = -\frac{\pi}{4}, e^{-3} y = \frac{e^{-3}}{3} + e^3$

$\Rightarrow y = e^6 + \frac{1}{3} \left[\because \tan\left(-\frac{\pi}{4}\right) = -1 \right]$

13. Given differential equation can be rewritten as $\frac{dy}{dx} + \left(\frac{2}{x}\right) \cdot y = x$, which is a linear differential equation of the form $\frac{dy}{dx} + Py = Q$, where $P = \frac{2}{x}$ and $Q = x$.

Now, integrating factor

(IF) = $e^{\int \frac{2}{x} dx} = e^{2 \log x} = e^{\log x^2} = x^2$

[$\because e^{\log f(x)} = f(x)$]

and the solution is given by

$y(\text{IF}) = \int (Q \times \text{IF}) dx + C$

$\Rightarrow yx^2 = \int x^3 dx + C$

$\Rightarrow yx^2 = \frac{x^4}{4} + C \dots(i)$

Since, it is given that $y = 1$ when $x = 1$

\therefore From Eq. (i), we get

$1 = \frac{1}{4} + C \Rightarrow C = \frac{3}{4} \dots(ii)$

$\therefore 4x^2 y = x^4 + 3$ [using Eqs. (i) and (ii)]

$\Rightarrow y = \frac{x^4 + 3}{4x^2}$

Now, $y\left(\frac{1}{2}\right) = \frac{1}{4 \times \frac{1}{4}} + \frac{3}{4} = \frac{49}{16}$

14. We have,

$\sin x \frac{dy}{dx} + y \cos x = 4x \Rightarrow \frac{dy}{dx} + y \cot x = 4x \operatorname{cosec} x$

This is a linear differential equation of form

$\frac{dy}{dx} + Py = Q$

where $P = \cot x, Q = 4x \operatorname{cosec} x$

Now, IF = $e^{\int P dx} = e^{\int \cot x dx} = e^{\log \sin x} = \sin x$

Solution of the differential equation is

$y \cdot \sin x = \int 4x \operatorname{cosec} x \sin x dx + C$

$\Rightarrow y \sin x = \int 4x dx + C = 2x^2 + C$

Put $x = \frac{\pi}{2}, y = 0$, we get

$C = -\frac{\pi^2}{2} \Rightarrow y \sin x = 2x^2 - \frac{\pi^2}{2}$

Put $x = \frac{\pi}{6}$

$\therefore y\left(\frac{1}{2}\right) = 2\left(\frac{\pi^2}{36}\right) - \frac{\pi^2}{2}$

$\Rightarrow y = \frac{\pi^2}{9} - \pi^2 \Rightarrow y = -\frac{8\pi^2}{9}$

Alternate Method

We have, $\sin x \frac{dy}{dx} + y \cos x = 4x$, which can be written as

$\frac{d}{dx} (\sin x \cdot y) = 4x$

On integrating both sides, we get

$\int \frac{d}{dx} (\sin x \cdot y) \cdot dx = \int 4x \cdot dx$

$\Rightarrow y \cdot \sin x = \frac{4x^2}{2} + C$

$\Rightarrow y \cdot \sin x = 2x^2 + C$

Now, as $y = 0$ when $x = \frac{\pi}{2}$

$\therefore C = -\frac{\pi^2}{2}$

$\Rightarrow y \cdot \sin x = 2x^2 - \frac{\pi^2}{2}$

Now, putting $x = \frac{\pi}{6}$, we get

$y\left(\frac{1}{2}\right) = 2\left(\frac{\pi^2}{36}\right) - \frac{\pi^2}{2}$

$\Rightarrow y = \frac{\pi^2}{9} - \pi^2 = -\frac{8\pi^2}{9}$

15. Given differential equation is

$y(1 + xy) dx = x dy$

$\Rightarrow y dx + xy^2 dx = x dy$

$\Rightarrow \frac{x dy - y dx}{y^2} = x dx$

$\Rightarrow -\frac{(y dx - x dy)}{y^2} = x dx \Rightarrow -d\left(\frac{x}{y}\right) = x dx$

On integrating both sides, we get

$-\frac{x}{y} = \frac{x^2}{2} + C \dots(i)$

\therefore It passes through $(1, -1)$.

$\therefore 1 = \frac{1}{2} + C \Rightarrow C = \frac{1}{2}$

370 Differential Equations

Now, from Eq. (i) $-\frac{x}{y} = \frac{x^2}{2} + \frac{1}{2}$

$$\Rightarrow x^2 + 1 = -\frac{2x}{y}$$

$$\Rightarrow y = -\frac{2x}{x^2 + 1}$$

$$\therefore f\left(-\frac{1}{2}\right) = \frac{4}{5}$$

16. Given differential equation is

$$(x \log x) \frac{dy}{dx} + y = 2x \log x$$

$$\Rightarrow \frac{dy}{dx} + \frac{y}{x \log x} = 2$$

This is a linear differential equation.

$$\therefore \text{IF} = e^{\int \frac{1}{x \log x} dx} = e^{\log(\log x)} = \log x$$

Now, the solution of given differential equation is given by

$$y \cdot \log x = \int \log x \cdot 2 dx$$

$$\Rightarrow y \cdot \log x = 2 \int \log x dx$$

$$\Rightarrow y \cdot \log x = 2 [x \log x - x] + c$$

At $x = 1 \Rightarrow c = 2$

$$\Rightarrow y \cdot \log x = 2 [x \log x - x] + 2$$

At $x = e, y = 2(e - e) + 2$

$$\Rightarrow y = 2$$

17. **PLAN** (i) Solution of the differential equation $\frac{dy}{dx} + Py = Q$ is

$$y \cdot (\text{IF}) = \int Q \cdot (\text{IF}) dx + c$$

where, $\text{IF} = e^{\int P dx}$

(ii) $\int_{-a}^a f(x) dx = 2 \int_0^a f(x) dx$, if $f(-x) = f(x)$

Given differential equation

$$\frac{dy}{dx} + \frac{x}{x^2 - 1} y = \frac{x^4 + 2x}{\sqrt{1 - x^2}}$$

This is a linear differential equation.

$$\text{IF} = e^{\int \frac{x}{x^2 - 1} dx} = e^{\frac{1}{2} \ln |x^2 - 1|} = \sqrt{1 - x^2}$$

$$\Rightarrow \text{Solution is } y \sqrt{1 - x^2} = \int \frac{x(x^3 + 2)}{\sqrt{1 - x^2}} \cdot \sqrt{1 - x^2} dx$$

$$\text{or } y \sqrt{1 - x^2} = \int (x^4 + 2x) dx = \frac{x^5}{5} + x^2 + c$$

$$f(0) = 0 \Rightarrow c = 0 \Rightarrow f(x) \sqrt{1 - x^2} = \frac{x^5}{5} + x^2$$

$$\text{Now, } \int_{-\sqrt{3}/2}^{\sqrt{3}/2} f(x) dx = \int_{-\sqrt{3}/2}^{\sqrt{3}/2} \frac{x^2}{\sqrt{1 - x^2}} dx$$

$$= 2 \int_0^{\sqrt{3}/2} \frac{x^2}{\sqrt{1 - x^2}} dx \quad [\text{using property}]$$

$$= 2 \int_0^{\pi/3} \frac{\sin^2 \theta}{\cos \theta} \cos \theta d\theta \quad [\text{taking } x = \sin \theta]$$

$$= 2 \int_0^{\pi/3} \sin^2 \theta d\theta = \int_0^{\pi/3} (1 - \cos 2\theta) d\theta$$

$$= \left(\theta - \frac{\sin 2\theta}{2} \right)_0^{\pi/3} = \frac{\pi}{3} - \frac{\sin 2\pi/3}{2} = \frac{\pi}{3} - \frac{\sqrt{3}}{4}$$

18. **PLAN** Whenever we have linear differential equation containing inequality, we should always check for increasing or decreasing,

$$\text{i.e. for } \frac{dy}{dx} + Py < 0 \Rightarrow \frac{dy}{dx} + Py > 0$$

Multiply by integrating factor, i.e. $e^{\int P dx}$ and convert into total differential equation.

Here, $f'(x) < 2f(x)$, multiplying by $e^{-\int 2 dx}$

$$f'(x) \cdot e^{-2x} - 2e^{-2x} f(x) < 0$$

$$\Rightarrow \frac{d}{dx} (f(x) \cdot e^{-2x}) < 0$$

$$\therefore \phi(x) = f(x)e^{-2x} \text{ is decreasing for } x \in \left[\frac{1}{2}, 1 \right]$$

Thus, when $x > \frac{1}{2}$

$$\phi(x) < \phi\left(\frac{1}{2}\right) \Rightarrow e^{-2x} f(x) < e^{-1} \cdot f\left(\frac{1}{2}\right)$$

$$\Rightarrow f(x) < e^{2x-1} \cdot 1, \text{ given } f\left(\frac{1}{2}\right) = 1$$

$$\Rightarrow 0 < \int_{1/2}^1 f(x) dx < \int_{1/2}^1 e^{2x-1} dx$$

$$\Rightarrow 0 < \int_{1/2}^1 f(x) dx < \left(\frac{e^{2x-1}}{2} \right)_{1/2}^1$$

$$\Rightarrow 0 < \int_{1/2}^1 f(x) dx < \frac{e-1}{2}$$

19. Given, $\lim_{t \rightarrow x} \frac{t^2 f(x) - x^2 f(t)}{t - x} = 1$

$$\Rightarrow x^2 f'(x) - 2x f(x) + 1 = 0$$

$$\Rightarrow \frac{x^2 f'(x) - 2x f(x)}{(x^2)^2} + \frac{1}{x^4} = 0$$

$$\Rightarrow \frac{d}{dx} \left(\frac{f(x)}{x^2} \right) = -\frac{1}{x^4}$$

On integrating both sides, we get

$$f(x) = cx^2 + \frac{1}{3x}$$

Also, $f(1) = 1, \quad c = \frac{2}{3}$

Hence, $f(x) = \frac{2}{3}x^2 + \frac{1}{3x}$

20. Given, $x dy = y(dx + y dy), y > 0$

$$\Rightarrow x dy - y dx = y^2 dy$$

$$\Rightarrow \frac{x dy - y dx}{y^2} = dy \Rightarrow d\left(\frac{x}{y}\right) = -dy$$

On integrating both sides, we get

$$\frac{x}{y} = -y + c \quad \dots(i)$$

Since, $y(1) = 1$

$$\Rightarrow x = 1, y = 1$$

$$\therefore c = 2$$

Now, Eq. (i) becomes, $\frac{x}{y} + y = 2$

Again, for $x = -3$

$$\Rightarrow -3 + y^2 = 2y$$

$$\Rightarrow y^2 - 2y - 3 = 0$$

$$\Rightarrow (y + 1)(y - 3) = 0$$

As $y > 0$, take $y = 3$, neglecting $y = -1$.

21. Given, $\frac{dy}{dt} - \left(\frac{t}{1+t}\right)y = \frac{1}{(1+t)}$ and $y(0) = -1$

Which represents linear differential equation of first order.

$$\therefore \text{IF} = e^{\int -\left(\frac{t}{1+t}\right)dt} = e^{-t + \log(1+t)} = e^{-t} \cdot (1+t)$$

Required solution is,

$$ye^{-t}(1+t) = \int \frac{1}{1+t} \cdot e^{-t}(1+t) dt + c = \int e^{-t} dt + c$$

$$\Rightarrow ye^{-t}(1+t) = -e^{-t} + c$$

Since, $y(0) = -1$

$$\Rightarrow -1 \cdot e^0(1+0) = -e^0 + c$$

$$c = 0$$

$$\therefore y = -\frac{1}{(1+t)} \Rightarrow y(1) = -\frac{1}{2}$$

22. Here, $f'(x) = 2 - \frac{f(x)}{x}$

or $\frac{dy}{dx} + \frac{y}{x} = 2$ [i.e. linear differential equation in y]

Integrating Factor, $\text{IF} = e^{\int \frac{1}{x} dx} = e^{\log x} = x$

\therefore Required solution is $y \cdot (\text{IF}) = \int Q(\text{IF}) dx + C$

$$\Rightarrow y(x) = \int 2(x) dx + C$$

$$\Rightarrow yx = x^2 + C$$

$$\therefore y = x + \frac{C}{x} \quad [\because C \neq 0, \text{ as } f(1) \neq 1]$$

(a) $\lim_{x \rightarrow 0^+} f'\left(\frac{1}{x}\right) = \lim_{x \rightarrow 0^+} (1 - Cx^2) = 1$

\therefore Option (a) is correct.

(b) $\lim_{x \rightarrow 0^+} x f\left(\frac{1}{x}\right) = \lim_{x \rightarrow 0^+} (1 + Cx^2) = 1$

\therefore Option (b) is incorrect.

(c) $\lim_{x \rightarrow 0^+} x^2 f'(x) = \lim_{x \rightarrow 0^+} (x^2 - C) = -C \neq 0$

\therefore Option (c) is incorrect.

(d) $f(x) = x + \frac{C}{x}, C \neq 0$

For $C > 0$, $\lim_{x \rightarrow 0^+} f(x) = \infty$

\therefore Function is not bounded in $(0, 2)$.

\therefore Option (d) is incorrect.

23. **PLAN** Linear differential equation under one variable.

$$\frac{dy}{dx} + Py = Q; \text{ IF} = e^{\int P dx}$$

\therefore Solution is, $y(\text{IF}) = \int Q \cdot (\text{IF}) dx + C$

$$y' - y \tan x = 2x \sec x \text{ and } y(0) = 0$$

$$\Rightarrow \frac{dy}{dx} - y \tan x = 2x \sec x$$

$$\therefore \text{IF} = \int e^{-\tan x} dx = e^{\log|\cos x|} = \cos x$$

Solution is $y \cdot \cos x = \int 2x \sec x \cdot \cos x dx + C$

$$\Rightarrow y \cdot \cos x = x^2 + C$$

As $y(0) = 0 \Rightarrow C = 0$

$$\therefore y = x^2 \sec x$$

Now, $y\left(\frac{\pi}{4}\right) = \frac{\pi^2}{8\sqrt{2}}$

$$\Rightarrow y'\left(\frac{\pi}{4}\right) = \frac{\pi}{\sqrt{2}} + \frac{\pi^2}{8\sqrt{2}}$$

$$y\left(\frac{\pi}{3}\right) = \frac{2\pi^2}{9} \Rightarrow y'\left(\frac{\pi}{3}\right) = \frac{4\pi}{3} + \frac{2\pi^2}{3\sqrt{3}}$$

24. Let $w(x) = u(x) - v(x)$... (i)

and $h(x) = f(x) - g(x)$

On differentiating Eq. (i) w.r.t. x

$$\frac{dw}{dx} = \frac{du}{dx} - \frac{dv}{dx}$$

$$= \{f(x) - p(x) \cdot u(x)\} - \{g(x) - p(x) v(x)\} \quad [\text{given}]$$

$$= \{f(x) - g(x)\} - p(x) [u(x) - v(x)]$$

$$\Rightarrow \frac{dw}{dx} = h(x) - p(x) \cdot w(x) \quad \dots(ii)$$

$\Rightarrow \frac{dw}{dx} + p(x)w(x) = h(x)$ which is linear differential equation.

The integrating factor is given by

$$\text{IF} = e^{\int p(x) dx} = r(x) \quad [\text{let}]$$

On multiplying both sides of Eq. (ii) of $r(x)$, we get

$$r(x) \cdot \frac{dw}{dx} + p(x) (r(x)) w(x) = r(x) \cdot h(x)$$

$$\Rightarrow \frac{d}{dx} [r(x) w(x)] = r(x) \cdot h(x) \quad \left[\because \frac{dr}{dx} = p(x) \cdot r(x) \right]$$

Now, $r(x) = e^{\int P(x) dx} > 0, \forall x$

and $h(x) = f(x) - g(x) > 0$, for $x > x_1$

Thus, $\frac{d}{dx} [r(x) w(x)] > 0, \forall x > x_1$

$r(x)w(x)$ increases on the interval $[x, \infty [$

372 Differential Equations

Therefore, for all $x > x_1$

$$r(x)w(x) > r(x_1)w(x_1) > 0$$

$$[\because r(x_1) > 0 \text{ and } u(x_1) > v(x_1)]$$

$$\Rightarrow w(x) > 0 \quad \forall x > x_1$$

$$\Rightarrow u(x) > v(x) \quad \forall x > x_1 \quad [\because r(x) > 0]$$

Hence, there cannot exist a point (x, y) such that $x > x_1$ and $y = u(x)$ and $y = v(x)$.

25. $\frac{dy}{dx} + y \cdot g'(x) = g(x)g'(x)$

$$\text{IF} = e^{\int g'(x) dx} = e^{g(x)}$$

$$\therefore \text{Solution is } y(e^{g(x)}) = \int g(x) \cdot g'(x) \cdot e^{g(x)} dx + C$$

Put $g(x) = t, g'(x) dx = dt$

$$y(e^{g(x)}) = \int t \cdot e^t dt + C$$

$$= t \cdot e^t - \int 1 \cdot e^t dt + C = t \cdot e^t - e^t + C$$

$$y e^{g(x)} = (g(x) - 1) e^{g(x)} + C \quad \dots(i)$$

Given, $y(0) = 0, g(0) = g(2) = 0$

\therefore Eq. (i) becomes,

$$y(0) \cdot e^{g(0)} = (g(0) - 1) \cdot e^{g(0)} + C$$

$$\Rightarrow 0 = (-1) \cdot 1 + C \Rightarrow C = 1$$

$$\therefore y(x) \cdot e^{g(x)} = (g(x) - 1) e^{g(x)} + 1$$

$$\Rightarrow y(2) \cdot e^{g(2)} = (g(2) - 1) e^{g(2)} + 1, \text{ where } g(2) = 0$$

$$\Rightarrow y(2) \cdot 1 = (-1) \cdot 1 + 1$$

$$y(2) = 0$$

Topic 3 Applications of Homogeneous Differential Equations

1. Given differential equation is

$$2x^2 dy = (2xy + y^2) dx$$

$$\Rightarrow \frac{dy}{dx} = \frac{2xy + y^2}{2x^2}$$

[Homogeneous differential equation]

Let $y = vx = \frac{dy}{dx} = v + x \frac{dv}{dx}$

\therefore The differential equation becomes

$$v + x \frac{dv}{dx} = \frac{2vx^2 + v^2x^2}{2x^2}$$

$$\Rightarrow x \frac{dv}{dx} = \frac{2v + v^2 - 2v}{2}$$

$$\Rightarrow x \frac{dv}{dx} = \frac{v^2}{2} \Rightarrow 2 \frac{dv}{v^2} = \frac{dx}{x}$$

$$\Rightarrow 2 \left(\frac{-1}{v} \right) = \log_e x + C \Rightarrow \log_e x + \frac{2x}{y} + C = 0 \quad \dots(i)$$

as $v = \frac{y}{x}$

\therefore The curve (i) passes through the point (1, 2).

So, $c = -1 \therefore \log_e x + \frac{2x}{y} = 1$

Now, at $x = \frac{1}{2}$

$$\log_e \left(\frac{1}{2} \right) + \frac{1}{y} = 1 \Rightarrow \frac{1}{y} = 1 + \log_e 2$$

$$\Rightarrow y = f \left(\frac{1}{2} \right) = \frac{1}{1 + \log_e 2}$$

Hence, option (a) is correct.

2. Given, $\frac{dy}{dx} = \frac{2y}{x^2}$

$$\Rightarrow \int \frac{dy}{y} = \int \frac{2}{x^2} dx \quad [\text{integrating both sides}]$$

$$\Rightarrow \log_e |y| = -\frac{2}{x} + C \quad \dots(i)$$

Since, curve (i) passes through centre (1, 1) of the circle

$$x^2 + y^2 - 2x - 2y = 0$$

$$\therefore \log_e(1) = -\frac{2}{1} + C \Rightarrow C = 2$$

\therefore Equation required curve is

$$\log_e |y| = -\frac{2}{x} + 2 \quad [\text{put } C = 2 \text{ in Eq. (i)}]$$

$$\Rightarrow x \log_e |y| = 2(x - 1)$$

3. Given differential equation is

$(x^2 - y^2)dx + 2xy dy = 0$, which can be written as

$$\frac{dy}{dx} = \frac{y^2 - x^2}{2xy}$$

Put $y = vx$ [\because it is in homogeneous form]

$$\Rightarrow \frac{dy}{dx} = v + x \frac{dv}{dx}$$

Now, differential equation becomes

$$v + x \frac{dv}{dx} = \frac{v^2x^2 - x^2}{2x(vx)} \Rightarrow v + x \frac{dv}{dx} = \frac{(v^2 - 1)x^2}{2vx^2}$$

$$\Rightarrow x \frac{dv}{dx} = \frac{v^2 - 1}{2v} - v = \frac{v^2 - 1 - 2v^2}{2v}$$

$$\Rightarrow x \frac{dv}{dx} = -\frac{1 + v^2}{2v} \Rightarrow \int \frac{2v dv}{1 + v^2} = -\int \frac{dx}{x}$$

$$\Rightarrow \ln(1 + v^2) = -\ln x - \ln C$$

$$\left[\because \int \frac{f'(x)}{f(x)} dx \Rightarrow \ln |f(x)| + C \right]$$

$$\Rightarrow \ln |(1 + v^2)Cx| = 0$$

$$[\because \ln A + \ln B = \ln AB]$$

$$\Rightarrow (1 + v^2)Cx = 1$$

$$[\log_e x = 0 \Rightarrow x = e^0 = 1]$$

Now, putting $v = \frac{y}{x}$, we get

$$\left(1 + \frac{y^2}{x^2} \right) Cx = 1 \Rightarrow C(x^2 + y^2) = x$$

\therefore The curve passes through (1, 1), so

$$C(1 + 1) = 1 \Rightarrow C = \frac{1}{2}$$

Thus, required curve is $x^2 + y^2 - 2x = 0$, which represent a circle having centre (1, 0)

\therefore The solution of given differential equation represents a circle with centre on the X-axis.

4. Given, differential equation is $\frac{dp}{dt} - \frac{1}{2}p(t) = -200$ is a linear differential equation.

Here, $p(t) = \frac{-1}{2}, Q(t) = -200$

$$\text{IF} = e^{\int -\left(\frac{1}{2}\right)dt} = e^{-\frac{t}{2}}$$

Hence, solution is

$$p(t) \cdot \text{IF} = \int Q(t) \cdot \text{IF} dt$$

$$p(t) \cdot e^{-\frac{t}{2}} = \int -200 \cdot e^{-\frac{t}{2}} dt$$

$$p(t) \cdot e^{-\frac{t}{2}} = 400 e^{-\frac{t}{2}} + K$$

$$\Rightarrow p(t) = 400 + ke^{-1/2}$$

If $p(0) = 100$, then $k = -300$

$$\Rightarrow p(t) = 400 - 300 e^{\frac{t}{2}}$$

5. **PLAN** To solve homogeneous differential equation, i.e. substitute $\frac{y}{x} = v$

$$\therefore y = vx \Rightarrow \frac{dy}{dx} = v + x \frac{dv}{dx}$$

Here, slope of the curve at (x, y) is

$$\frac{dy}{dx} = \frac{y}{x} + \sec\left(\frac{y}{x}\right)$$

Put $\frac{y}{x} = v$

$$\therefore v + x \frac{dv}{dx} = v + \sec(v) \Rightarrow x \frac{dv}{dx} = \sec(v)$$

$$\Rightarrow \int \frac{dv}{\sec v} = \int \frac{dx}{x} \Rightarrow \int \cos v dv = \int \frac{dx}{x}$$

$$\Rightarrow \sin v = \log x + \log c \Rightarrow \sin\left(\frac{y}{x}\right) = \log(cx)$$

As it passes through $\left(1, \frac{\pi}{6}\right) \Rightarrow \sin\left(\frac{\pi}{6}\right) = \log c$

$$\Rightarrow \log c = \frac{1}{2}$$

$$\therefore \sin\left(\frac{y}{x}\right) = \log x + \frac{1}{2}$$

6. Given, $\frac{dP}{dx} = (100 - 12\sqrt{x})$

$$\Rightarrow dP = (100 - 12\sqrt{x}) dx$$

On integrating both sides, we get

$$\int dP = \int (100 - 12\sqrt{x}) dx$$

$$P = 100x - 8x^{3/2} + C$$

When $x = 0$, then $P = 2000 \Rightarrow C = 2000$

Now, when $x = 25$, then is

$$\begin{aligned} P &= 100 \times 25 - 8 \times (25)^{3/2} + 2000 \\ &= 2500 - 8 \times 125 + 2000 \\ &= 4500 - 1000 = 3500 \end{aligned}$$

7. Let a point $P(h, k)$ on the curve $y = y(x)$, so equation of tangent to the curve at point P is

$$y - k = \left(\frac{dy}{dx}\right)_{h,k} (x - h) \quad \dots(i)$$

Now, the tangent (i) intersect the Y -axis at Y_p , so coordinates Y_p is $\left(0, k - h \frac{dy}{dx}\right)$, where $\frac{dy}{dx} = \left(\frac{dy}{dx}\right)_{(h,k)}$

So, $PY_p = 1$ (given)

$$\Rightarrow \sqrt{h^2 + h^2 \left(\frac{dy}{dx}\right)^2} = 1$$

$$\Rightarrow \frac{dy}{dx} = \pm \frac{\sqrt{1-x^2}}{x} \quad [\text{on replacing } h \text{ by } x]$$

$$\Rightarrow dy = \pm \frac{\sqrt{1-x^2}}{x} dx$$

On putting $x = \sin \theta$, $dx = \cos \theta d\theta$, we get

$$dy = \pm \frac{\sqrt{1-\sin^2 \theta}}{\sin \theta} \cos \theta d\theta = \pm \frac{\cos^2 \theta}{\sin \theta} d\theta$$

$$= \pm (\cos \theta d\theta - \sin \theta) d\theta$$

$$\Rightarrow y = \pm [\ln(\cos \theta - \cot \theta) + \cos \theta] + C$$

$$\Rightarrow y = \pm \left[\ln\left(\frac{1-\cos \theta}{\sin \theta}\right) + \cos \theta \right] + C$$

$$\Rightarrow y = \pm \left[\ln\left(\frac{1-\sqrt{1-\sin^2 \theta}}{\sin \theta}\right) + \sqrt{1-\sin^2 \theta} \right] + C$$

$$\Rightarrow y = \pm \left[\ln\left(\frac{1-\sqrt{1-x^2}}{x}\right) + \sqrt{1-x^2} \right] + C \quad [\because x = \sin \theta]$$

$$= \pm \left[-\ln \frac{1+\sqrt{1-x^2}}{x} + \sqrt{1-x^2} \right] + C$$

[on rationalization]

\therefore The curve is in the first quadrant so y must be positive, so

$$y = \ln\left(\frac{1+\sqrt{1-x^2}}{x}\right) - \sqrt{1-x^2} + C$$

As curve passes through $(1, 0)$, so

$$0 = 0 - 0 + c \Rightarrow c = 0, \text{ so required curve is}$$

$$y = \ln\left(\frac{1+\sqrt{1-x^2}}{x}\right) - \sqrt{1-x^2}$$

and required differential equation is

$$\frac{dy}{dx} = -\frac{\sqrt{1-x^2}}{x}$$

$$\Rightarrow xy' + \sqrt{1-x^2} = 0$$

Hence, options (a) and (c) are correct.

8. Given, $(x^2 + xy + 4x + 2y + 4) \frac{dy}{dx} - y^2 = 0$

$$\Rightarrow [(x^2 + 4x + 4) + y(x + 2)] \frac{dy}{dx} - y^2 = 0$$

$$\Rightarrow [(x+2)^2 + y(x+2)] \frac{dy}{dx} - y^2 = 0$$

374 Differential Equations

Put $x + 2 = X$ and $y = Y$, then

$$\begin{aligned} & (X^2 + XY) \frac{dY}{dX} - Y^2 = 0 \\ \Rightarrow & X^2 dY + XY dY - Y^2 dX = 0 \\ \Rightarrow & X^2 dY + Y(XdY - YdX) = 0 \\ \Rightarrow & -\frac{dY}{Y} = \frac{XdY - YdX}{X^2} \\ \Rightarrow & -d(\log |Y|) = d\left(\frac{Y}{X}\right) \end{aligned}$$

On integrating both sides, we get

$$\begin{aligned} -\log |Y| &= \frac{Y}{X} + C, \text{ where } x + 2 = X \text{ and } y = Y \\ \Rightarrow -\log |y| &= \frac{y}{x+2} + C \quad \dots(i) \end{aligned}$$

Since, it passes through the point (1, 3).

$$\begin{aligned} \therefore -\log 3 &= 1 + C \\ \Rightarrow C &= -1 - \log 3 = -(\log e + \log 3) \\ &= -\log 3e \end{aligned}$$

\therefore Eq. (i) becomes

$$\begin{aligned} \log |y| + \frac{y}{x+2} - \log(3e) &= 0 \\ \Rightarrow \log\left(\frac{|y|}{3e}\right) + \frac{y}{x+2} &= 0 \quad \dots(ii) \end{aligned}$$

Now, to check option (a), $y = x + 2$ intersects the curve.

$$\begin{aligned} \Rightarrow \log\left(\frac{|x+2|}{3e}\right) + \frac{x+2}{x+2} &= 0 \Rightarrow \log\left(\frac{|x+2|}{3e}\right) = -1 \\ \Rightarrow \frac{|x+2|}{3e} &= e^{-1} = \frac{1}{e} \\ \Rightarrow |x+2| &= 3 \text{ or } x+2 = \pm 3 \\ \therefore x &= 1, -5 \text{ (rejected), as } x > 0 \quad \text{[given]} \\ \therefore x &= 1 \text{ only one solution.} \end{aligned}$$

Thus, (a) is the correct answer.

To check option (c), we have

$$\begin{aligned} y &= (x+2)^2 \text{ and } \log\left(\frac{|y|}{3e}\right) + \frac{y}{x+2} = 0 \\ \Rightarrow \log\left[\frac{|x+2|^2}{3e}\right] + \frac{(x+2)^2}{x+2} &= 0 \Rightarrow \log\left[\frac{|x+2|^2}{3e}\right] = -(x+2) \\ \Rightarrow \frac{(x+2)^2}{3e} &= e^{-(x+2)} \text{ or } (x+2)^2 \cdot e^{x+2} = 3e \Rightarrow e^{x+2} = \frac{3e}{(x+2)^2} \end{aligned}$$

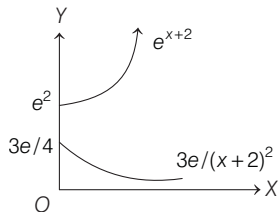

Clearly, they have no solution.

To check option (d), $y = (x+3)^2$

$$\text{i.e. } \log\left[\frac{|x+3|^2}{3e}\right] + \frac{(x+3)^2}{(x+2)} = 0$$

To check the number of solutions.

$$\text{Let } g(x) = 2 \log(x+3) + \frac{(x+3)^2}{(x+2)} - \log(3e)$$

$$\begin{aligned} \therefore g'(x) &= \frac{2}{x+3} + \left(\frac{(x+2) \cdot 2(x+3) - (x+3)^2 \cdot 1}{(x+2)^2}\right) - 0 \\ &= \frac{2}{x+3} + \frac{(x+3)(x+1)}{(x+2)^2} \end{aligned}$$

Clearly, when $x > 0$, then, $g'(x) > 0$

$\therefore g(x)$ is increasing, when $x > 0$.

Thus, when $x > 0$, then $g(x) > g(0)$

$$g(x) > \log\left(\frac{3}{e}\right) + \frac{9}{4} > 0$$

Hence, there is no solution. Thus, option (d) is true.

9. Since, $BP : AP = 3 : 1$. Then, equation of tangent is

$$Y - y = f'(x)(X - x)$$

The intercept on the coordinate axes are

$$A\left(x - \frac{y}{f'(x)}, 0\right)$$

and $B[0, y - x f'(x)]$

Since, P is internally intercepts a line AB ,

$$\begin{aligned} \therefore x &= \frac{3\left(x - \frac{y}{f'(x)}\right) + 1 \times 0}{3 + 1} \end{aligned}$$

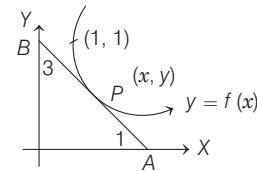

$$\Rightarrow \frac{dy}{dx} = \frac{y}{-3x} \Rightarrow \frac{dy}{y} = -\frac{1}{3x} dx$$

On integrating both sides, we get

$$xy^3 = c$$

Since, curve passes through (1, 1), then $c = 1$.

$$\therefore xy^3 = 1$$

$$\text{At } x = \frac{1}{8} \Rightarrow y = 2$$

Hence, (a) and (c) are correct answers.

10. Since, rate of change of volume \propto surface area

$$\Rightarrow \frac{dV}{dt} \propto \text{SA}$$

$$\Rightarrow 4\pi r^2 \cdot \frac{dr}{dt} = -\lambda 4\pi r^2$$

$$\frac{dr}{dt} = -\lambda \text{ is required differential equation.}$$

11. Since, the length of tangent = $\left| y \sqrt{1 + \left(\frac{dx}{dy}\right)^2} \right| = 1$

$$\Rightarrow y^2 \left(1 + \left(\frac{dx}{dy}\right)^2 \right) = 1$$

$$\therefore \frac{dy}{dx} = \pm \frac{y}{\sqrt{1-y^2}}$$

$$\Rightarrow \int \frac{\sqrt{1-y^2}}{y} dy = \pm \int x dx$$

$$\Rightarrow \int \frac{\sqrt{1-y^2}}{y} dy = \pm x + C$$

Put $y = \sin \theta \Rightarrow dy = \cos \theta d\theta$

$$\therefore \int \frac{\cos \theta}{\sin \theta} \cdot \cos \theta d\theta = \pm x + C$$

$$\Rightarrow \int \frac{\cos^2 \theta}{\sin^2 \theta} \cdot \sin \theta d\theta = \pm x + C$$

Again put $\cos \theta = t \Rightarrow -\sin \theta d\theta = dt$

$$\therefore -\int \frac{t^2}{1-t^2} dt = \pm x + C$$

$$\Rightarrow \int \left(1 - \frac{1}{1-t^2} \right) dt = \pm x + C$$

$$\Rightarrow t - \log \left| \frac{1+t}{1-t} \right| = \pm x + C$$

$$\Rightarrow \sqrt{1-y^2} - \log \left| \frac{1+\sqrt{1-y^2}}{1-\sqrt{1-y^2}} \right| = \pm x + C$$

12. Given, liquid evaporates at a rate proportional to its surface area.

$$\Rightarrow \frac{dV}{dt} \propto -S \quad \dots(i)$$

We know that, volume of cone = $\frac{1}{3} \pi r^2 h$

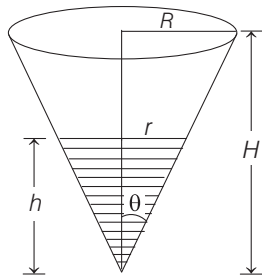

and surface area = πr^2

$$\text{or } V = \frac{1}{3} \pi r^2 h \text{ and } S = \pi r^2 \quad \dots(ii)$$

$$\text{Where, } \tan \theta = \frac{R}{H} \text{ and } \frac{r}{h} = \tan \theta \quad \dots(iii)$$

From Eqs. (ii) and (iii), we get

$$V = \frac{1}{3} \pi r^3 \cot \theta \text{ and } S = \pi r^2 \quad \dots(iv)$$

On substituting Eq. (iv) in Eq. (i), we get

$$\frac{1}{3} \cot \theta \cdot 3r^2 \frac{dr}{dt} = -k\pi r^2$$

$$\Rightarrow \cot \theta \int_R^0 dr = -k \int_0^T dt$$

$$\Rightarrow \cot \theta (0 - R) = -k (T - 0)$$

$$\Rightarrow R \cot \theta = kT \Rightarrow H = kT \text{ [from Eq. (iii)]}$$

$$\Rightarrow T = \frac{H}{k}$$

\therefore Required time after which the cone is empty, $T = \frac{H}{k}$

13. Let O be the centre of hemispherical tank. Let at any instant t , water level be BAB_1 and at $t + dt$, water level is $B' A' B'_1$. Let $\angle O_1 O B_1 = \theta$.

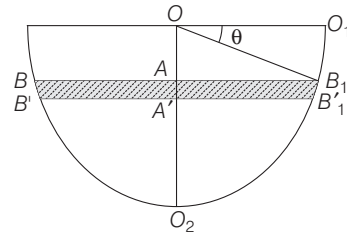

$\Rightarrow AB_1 = r \cos \theta$ and $OA = r \sin \theta$ decrease in the water volume in time $dt = \pi AB_1^2 \cdot d(OA)$

$[\pi r^2$ is surface area of water level and $d(OA)$ is depth of water level]

$$= \pi r^2 \cdot \cos^2 \theta \cdot r \cos \theta d\theta$$

$$= \pi r^3 \cdot \cos^3 \theta d\theta$$

Also, $h(t) = O_2 A = r - r \sin \theta = r(1 - \sin \theta)$

Now, outflow rate $Q = A \cdot v(t) = A \cdot 0.6 \sqrt{2gr} (1 - \sin \theta)$

Where, A is the area of the outlet.

Thus, volume flowing out in time dt .

$$\Rightarrow Q dt = A \cdot (0.6) \cdot \sqrt{2gr} \cdot \sqrt{1 - \sin \theta} dt$$

We have, $\pi r^3 \cos^3 \theta d\theta = A (0.6) \cdot \sqrt{2gr} \cdot \sqrt{1 - \sin \theta} dt$

$$\Rightarrow \frac{\pi r^3}{A (0.6) \sqrt{2gr}} \cdot \frac{\cos^3 \theta}{\sqrt{1 - \sin \theta}} d\theta = dt$$

Let the time taken to empty the tank be T .

$$\text{Then, } T = \int_0^{\pi/2} \frac{\pi r^3}{A (0.6) \sqrt{2gr}} \cdot \frac{\cos^3 \theta}{\sqrt{1 - \sin \theta}} d\theta$$

$$= \frac{-\pi r^3}{A (0.6) \sqrt{2gr}} \int_0^{\pi/2} \frac{1 - \sin^2 \theta (-\cos \theta)}{\sqrt{1 - \sin \theta}} d\theta$$

Let $t_1 = \sqrt{1 - \sin \theta}$

$$\Rightarrow dt_1 = \frac{-\cos \theta}{\sqrt{1 - \sin \theta}} d\theta$$

$$\therefore T = \frac{-2\pi r^3}{A (0.6) \sqrt{2gr}} \int_1^0 [1 - (1 - t_1^2)^2] dt_1$$

$$\Rightarrow T = \frac{-2\pi r^3}{A (0.6) \sqrt{2gr}} \int_1^0 [1 - (1 + t_1^4 - 2t_1^2)] dt_1$$

376 Differential Equations

$$\begin{aligned} \Rightarrow T &= \frac{-2\pi r^3}{A(0.6)\sqrt{2gr}} \int_1^0 [1 - 1 - t_1^4 + 2t_1^2] dt_1 \\ \Rightarrow T &= \frac{2\pi r^3}{A(0.6)\sqrt{2gr}} \int_1^0 (t_1^4 - 2t_1^2) dt_1 \\ \Rightarrow T &= \frac{2\pi r^3}{A(0.6)\sqrt{2gr}} \left[\frac{t_1^5}{5} - \frac{2t_1^3}{3} \right]_1^0 \\ \Rightarrow T &= \frac{2\pi \cdot r^{5/2}}{A\left(\frac{6}{10}\right)\sqrt{2gr}} \left[0 - \frac{1}{5} - 0 + \frac{2}{3} \right] \\ \Rightarrow T &= \frac{2\pi \cdot 2^{5/2} (10^2)^{5/2}}{12 \cdot \frac{3}{5} \cdot \sqrt{2} \cdot \sqrt{g}} \left[\frac{2}{3} - \frac{1}{5} \right] \\ &= \frac{2\pi \times 10^5 \cdot 4 \cdot 5}{(12 \times 3) \sqrt{g}} \left[\frac{10 - 3}{15} \right] \\ &= \frac{2\pi \times 10^5 \times 7}{3 \cdot 3 \cdot \sqrt{g} \cdot 3} = \frac{14\pi \times 10^5}{27 \sqrt{g}} \text{ unit} \end{aligned}$$

14. Let X_0 be initial population of the country and Y_0 be its initial food production. Let the average consumption be a unit. Therefore, food required initially aX_0 . It is given

$$Y_p = aX_0 \left(\frac{90}{100} \right) = 0.9 aX_0 \quad \dots(i)$$

Let X be the population of the country in year t .

Then, $\frac{dX}{dt}$ = Rate of change of population

$$= \frac{3}{100} X = 0.03 X$$

$$\Rightarrow \frac{dX}{X} = 0.03 dt$$

$$\Rightarrow \int \frac{dX}{X} = \int 0.03 dt$$

$$\Rightarrow \log X = 0.03 t + c$$

$$\Rightarrow X = A \cdot e^{0.03 t}, \text{ where } A = e^c$$

At $t = 0, X = X_0$, thus $X_0 = A$

$$\therefore X = X_0 e^{0.03 t}$$

Let Y be the food production in year t .

$$\text{Then, } Y = Y_0 \left(1 + \frac{4}{100} \right)^t = 0.9 aX_0 (1.04)^t$$

$$\therefore Y_0 = 0.9 aX_0 \quad [\text{from Eq. (i)}]$$

Food consumption in the year t is $aX_0 e^{0.03 t}$.

$$\text{Again, } Y - X \geq 0 \quad [\text{given}]$$

$$\Rightarrow 0.9 X_0 a (1.04)^t > a X_0 e^{0.03 t}$$

$$\Rightarrow \frac{(1.04)^t}{e^{0.03 t}} > \frac{1}{0.9} = \frac{10}{9}$$

Taking log on both sides, we get

$$\begin{aligned} t[\log(1.04) - 0.03] &\geq \log 10 - \log 9 \\ \Rightarrow t &\geq \frac{\log 10 - \log 9}{\log(1.04) - 0.03} \end{aligned}$$

Thus, the least integral values of the year n , when the country becomes self-sufficient is the smallest integer greater than or equal to $\frac{\log 10 - \log 9}{\log(1.04) - 0.03}$.

15. Equation of normal at point (x, y) is

$$Y - y = -\frac{dx}{dy}(X - x) \quad \dots(i)$$

Distance of perpendicular from the origin to Eq. (i)

$$= \frac{\left| y + \frac{dx}{dy} \cdot x \right|}{\sqrt{1 + \left(\frac{dx}{dy} \right)^2}}$$

Also, distance between P and X -axis is $|y|$.

$$\therefore \frac{\left| y + \frac{dx}{dy} \cdot x \right|}{\sqrt{1 + \left(\frac{dx}{dy} \right)^2}} = |y|$$

$$\Rightarrow y^2 + \frac{dx}{dy} \cdot x^2 + 2xy \frac{dx}{dy} = y^2 \left[1 + \left(\frac{dx}{dy} \right)^2 \right]$$

$$\Rightarrow \left(\frac{dx}{dy} \right)^2 (x^2 - y^2) + 2xy \frac{dx}{dy} = 0$$

$$\Rightarrow \frac{dx}{dy} \left[\left(\frac{dx}{dy} \right) (x^2 - y^2) + 2xy \right] = 0$$

$$\Rightarrow \frac{dx}{dy} = 0 \quad \text{or} \quad \frac{dy}{dx} = \frac{y^2 - x^2}{2xy}$$

$$\text{But } \frac{dx}{dy} = 0$$

$$\Rightarrow x = c, \text{ where } c \text{ is a constant.}$$

Since, curve passes through $(1, 1)$, we get the equation of the curve as $x = 1$.

The equation $\frac{dy}{dx} = \frac{y^2 - x^2}{2xy}$ is a homogeneous equation.

$$\text{Put } y = vx \Rightarrow \frac{dy}{dx} = v + x \frac{dv}{dx}$$

$$v + x \frac{dv}{dx} = \frac{v^2 x^2 - x^2}{2x^2 v}$$

$$\Rightarrow x \frac{dv}{dx} = \frac{v^2 - 1}{2v} - v = \frac{v^2 - 1 - 2v^2}{2v} = -\frac{v^2 + 1}{2v}$$

$$\Rightarrow \frac{-2v}{v^2 + 1} dv = \frac{dx}{x}$$

$$\Rightarrow c_1 - \log(v^2 + 1) = \log|x|$$

$$\Rightarrow \log|x|(v^2 + 1) = c_1 \Rightarrow |x| \left(\frac{y^2}{x^2} + 1 \right) = e^{c_1}$$

$\Rightarrow x^2 + y^2 = \pm e^{c_1} x$ or $x^2 + y^2 = \pm e^c x$ is passing through $(1, 1)$.

$$\therefore 1 + 1 = \pm e^c \cdot 1$$

$$\Rightarrow \pm e^c = 2$$

Hence, required curve is $x^2 + y^2 = 2x$.

16. $\frac{dV}{dt} \propto V$ for each reservoir.

$$\frac{dV}{dx} \propto -V_A \Rightarrow \frac{dV_A}{dt} = -K_1 V_A$$

[K_1 is the proportional constant]

$$\Rightarrow \int_{V_A}^{V'_A} \frac{dV_A}{V_A} = -K_1 \int_0^t dt$$

$$\Rightarrow \log \frac{V'_A}{V_A} = -K_1 t \Rightarrow V'_A = V_A \cdot e^{-K_1 t} \quad \dots(i)$$

$$\text{Similarly for } B, \quad V'_B = V_B \cdot e^{-K_2 t} \quad \dots(ii)$$

On dividing Eq. (i) by Eq. (ii), we get

$$\frac{V'_A}{V'_B} = \frac{V_A}{V_B} \cdot e^{-(K_1 - K_2)t}$$

It is given that at $t=0, V_A = 2V_B$ and at

$$t = \frac{3}{2}, V'_A = \frac{3}{2} V'_B$$

$$\text{Thus, } \frac{3}{2} = 2 \cdot e^{-(K_1 - K_2)t} \Rightarrow e^{-(K_1 - K_2)t} = \frac{3}{4} \quad \dots(iii)$$

Now, let at $t = t_0$ both the reservoirs have some quantity of water. Then,

$$V'_A = V'_B$$

From Eq. (iii), $2e^{-(K_1 - K_2)t} = 1$

$$\Rightarrow 2 \cdot \left(\frac{3}{4}\right)^{t_0} = 1$$

$$t_0 = \log_{3/4} (1/2)$$

17. Given, $\frac{dy}{dx} = \sin(10x + 6y)$

$$\text{Let } 10x + 6y = t \quad \dots(i)$$

$$\Rightarrow 10 + 6 \frac{dy}{dx} = \left(\frac{dt}{dx}\right)$$

$$\Rightarrow \frac{dy}{dx} = \frac{1}{6} \left(\frac{dt}{dx} - 10\right)$$

Now, the given differential equation becomes

$$\sin t = \frac{1}{6} \left(\frac{dt}{dx} - 10\right)$$

$$\Rightarrow 6 \sin t = \frac{dt}{dx} - 10$$

$$\Rightarrow \frac{dt}{dx} = 6 \sin t + 10$$

$$\Rightarrow \frac{dt}{6 \sin t + 10} = dx$$

On integrating both sides, we get

$$\frac{1}{2} \int \frac{dt}{3 \sin t + 5} = x + c \quad \dots(ii)$$

$$\text{Let } I_1 = \int \frac{dt}{3 \sin t + 5} = \int \frac{dt}{3 \left(\frac{2 \tan t/2}{1 + \tan^2 t/2}\right) + 5}$$

$$= \int \frac{(1 + \tan^2 t/2) dt}{\left(6 \tan \frac{t}{2} + 5 + 5 \tan^2 \frac{t}{2}\right)}$$

Put $\tan t/2 = u$

$$\Rightarrow \frac{1}{2} \sec^2 t/2 dt = du \Rightarrow dt = \frac{2 du}{\sec^2 t/2}$$

$$\Rightarrow dt = \frac{2 du}{1 + \tan^2 t/2} \Rightarrow dt = \frac{2 du}{1 + u^2}$$

$$\therefore I_1 = \int \frac{2(1 + u^2) du}{(1 + u^2)(5u^2 + 6u + 5)} = \frac{2}{5} \int \frac{du}{u^2 + \frac{6}{5}u + 1}$$

$$= \frac{2}{5} \int \frac{du}{u^2 + \frac{6}{5}u + \frac{9}{25} - \frac{9}{25} + 1}$$

$$= \frac{2}{5} \int \frac{du}{\left(u + \frac{3}{5}\right)^2 + \left(\frac{4}{5}\right)^2}$$

$$= \frac{2}{5} \cdot \frac{5}{4} \tan^{-1} \left(\frac{u + 3/5}{4/5}\right)$$

$$= \frac{1}{2} \tan^{-1} \left[\frac{5u + 3}{4}\right]$$

$$= \frac{1}{2} \tan^{-1} \left[\frac{5 \tan t/2 + 3}{4}\right]$$

On putting this in Eq. (ii), we get

$$\frac{1}{4} \tan^{-1} \left[\frac{5 \tan \frac{t}{2} + 3}{4}\right] = x + c$$

$$\Rightarrow \tan^{-1} \left[\frac{5 \tan \frac{t}{2} + 3}{4}\right] = 4x + 4c$$

$$\Rightarrow \frac{1}{4} [5 \tan(5x + 3y) + 3] = \tan(4x + 4c)$$

$$\Rightarrow 5 \tan(5x + 3y) + 3 = 4 \tan(4x + 4c)$$

When $x=0, y=0$, we get

$$5 \tan 0 + 3 = 4 \tan(4c)$$

$$\Rightarrow \frac{3}{4} = \tan 4c$$

$$\Rightarrow 4c = \tan^{-1} \frac{3}{4}$$

$$\text{Then, } 5 \tan(5x + 3y) + 3 = 4 \tan\left(4x + \tan^{-1} \frac{3}{4}\right)$$

$$\Rightarrow \tan(5x + 3y) = \frac{4}{5} \tan\left(4x + \tan^{-1} \frac{3}{4}\right) - \frac{3}{5}$$

$$\Rightarrow 5x + 3y = \tan^{-1} \left[\frac{4}{5} \left\{\tan\left(4x + \tan^{-1} \frac{3}{4}\right)\right\} - \frac{3}{5}\right]$$

$$\Rightarrow 3y = \tan^{-1} \left[\frac{4}{5} \left\{\tan\left(4x + \tan^{-1} \frac{3}{4}\right)\right\} - \frac{3}{5}\right] - 5x$$

$$\Rightarrow y = \frac{1}{3} \tan^{-1} \left[\frac{4}{5} \left\{\tan\left(4x + \tan^{-1} \frac{3}{4}\right)\right\} - \frac{3}{5}\right] - \frac{5x}{3}$$

378 Differential Equations

18. A. $I = \int_0^{\pi/2} (\sin x)^{\cos x} \{\cos x \cdot \cot x - \log (\sin x)^{\sin x}\} dx$
 $= \int_0^{\pi/2} \frac{d}{dx} (\sin x)^{\cos x} dx = 1$

B. The point of intersection of $-4y^2 = x$ and $x - 1 = -5y^2$ is $(-4, -1)$ and $(-4, 1)$.

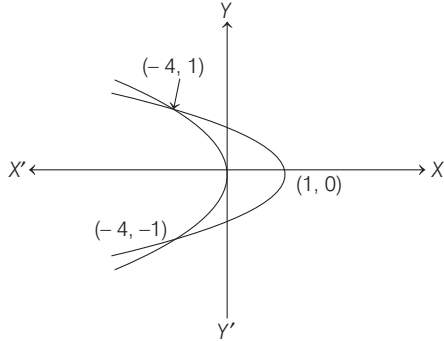

∴ Required area

$$= 2 \left\{ \int_0^1 (1 - 5y^2) dy - \int_0^1 -4y^2 dy \right\}$$

$$= 2 \int_0^1 (1 - y^2) dy = 2 \left[y - \frac{y^3}{3} \right]_0^1 = \frac{4}{3} \text{ sq units}$$

C. The point of intersection $y = 3^{x-1} \log x$ and $y = x^x - 1$ is $(1, 0)$.

Hence, $\frac{dy}{dx} = \frac{3^{x-1}}{x} + 3^{x-1} \cdot \log 3 \cdot \log x$

∴ $\left(\frac{dy}{dx}\right)_{(1,0)} = 1$

For $y = x^x - 1$
 $\Rightarrow \frac{dy}{dx} = x^x (1 + \log x)$

∴ $\left(\frac{dy}{dx}\right)_{(1,0)} = 1$

If θ is angle between the curves, then $\tan \theta = 0$.

$\Rightarrow \theta = 0^\circ$

D. $\frac{dy}{dx} = \frac{2}{x+y}$

$\Rightarrow \frac{dx}{dy} - \frac{x}{2} = \frac{y}{2}$

$\Rightarrow xe^{-y/2} = \frac{1}{2} \int y \cdot e^{-y/2} dy$

$\Rightarrow xe^{-y/2} = \frac{1}{2} \left[\frac{ye^{-y/2}}{-1/2} - \frac{e^{-y/2}}{(1/2)^2} \right] + k$

$\Rightarrow x + y + 2 = ke^{y/2}$

It passing through $(1, 0)$.

$\Rightarrow k = 3$

∴ $x + y + 2 = 3e^{y/2}$

15

Straight Line and Pair of Straight Lines

Topic 1 Various Forms of Straight Line

Objective Questions I (Only one correct option)

- The set of all possible values of θ in the interval $(0, \pi)$ for which the points $(1, 2)$ and $(\sin \theta, \cos \theta)$ lie on the same side of the line $x + y = 1$ is (2020 Main, 2 Sep II)
(a) $\left(0, \frac{\pi}{2}\right)$ (b) $\left(\frac{\pi}{4}, \frac{3\pi}{4}\right)$
(c) $\left(0, \frac{3\pi}{4}\right)$ (d) $\left(0, \frac{\pi}{4}\right)$
- A straight line L at a distance of 4 units from the origin makes positive intercepts on the coordinate axes and the perpendicular from the origin to this line makes an angle of 60° with the line $x + y = 0$. Then, an equation of the line L is (2019 Main, 12 April II)
(a) $x + \sqrt{3}y = 8$
(b) $(\sqrt{3} + 1)x + (\sqrt{3} - 1)y = 8\sqrt{2}$
(c) $\sqrt{3}x + y = 8$
(d) $(\sqrt{3} - 1)x + (\sqrt{3} + 1)y = 8\sqrt{2}$
- The equation $y = \sin x \sin(x + 2) - \sin^2(x + 1)$ represents a straight line lying in (2019 Main, 12 April I)
(a) second and third quadrants only
(b) first, second and fourth quadrants
(c) first, third and fourth quadrants
(d) third and fourth quadrants only
- Lines are drawn parallel to the line $4x - 3y + 2 = 0$, at a distance $\frac{3}{5}$ from the origin. Then which one of the following points lies on any of these lines? (2019 Main, 10 April I)
(a) $\left(-\frac{1}{4}, -\frac{2}{3}\right)$ (b) $\left(-\frac{1}{4}, \frac{2}{3}\right)$
(c) $\left(\frac{1}{4}, -\frac{1}{3}\right)$ (d) $\left(\frac{1}{4}, \frac{1}{3}\right)$
- The region represented by $|x - y| \leq 2$ and $|x + y| \leq 2$ is bounded by a (2019 Main, 10 April I)
(a) rhombus of side length 2 units
(b) rhombus of area $8\sqrt{2}$ sq units
(c) square of side length $2\sqrt{2}$ units
(d) square of area 16 sq units
- If the two lines $x + (a - 1)y = 1$ and $2x + a^2y = 1$, ($a \in \mathbb{R} - \{0, 1\}$) are perpendicular, then the distance of their point of intersection from the origin is (2019 Main, 9 April II)
(a) $\frac{2}{5}$ (b) $\frac{\sqrt{2}}{5}$
(c) $\frac{2}{\sqrt{5}}$ (d) $\frac{\sqrt{2}}{\sqrt{5}}$
- Slope of a line passing through $P(2, 3)$ and intersecting the line, $x + y = 7$ at a distance of 4 units from P , is (2019 Main, 9 April I)
(a) $\frac{1 - \sqrt{5}}{1 + \sqrt{5}}$ (b) $\frac{\sqrt{7} - 1}{\sqrt{7} + 1}$
(c) $\frac{1 - \sqrt{7}}{1 + \sqrt{7}}$ (d) $\frac{\sqrt{5} - 1}{\sqrt{5} + 1}$
- If a point $R(4, y, z)$ lies on the line segment joining the points $P(2, -3, 4)$ and $Q(8, 0, 10)$, then the distance of R from the origin is (2019 Main, 8 April II)
(a) $2\sqrt{21}$ (b) $\sqrt{53}$ (c) $2\sqrt{14}$ (d) 6
- Suppose that the points (h, k) , $(1, 2)$ and $(-3, 4)$ lie on the line L_1 . If a line L_2 passing through the points (h, k) and $(4, 3)$ is perpendicular to L_1 , then k/h equals (2019 Main, 8 April II)
(a) $-\frac{1}{7}$ (b) $\frac{1}{3}$
(c) 3 (d) 0

380 Straight Line and Pair of Straight Lines

10. A point on the straight line, $3x + 5y = 15$ which is equidistant from the coordinate axes will lie only in
(2019 Main, 8 April I)
- (a) IV quadrant (b) I quadrant
(c) I and II quadrants (d) I, II and IV quadrants
11. If a straight line passing through the point $P(-3, 4)$ is such that its intercepted portion between the coordinate axes is bisected at P , then its equation is
(2019 Main, 12 Jan II)
- (a) $x - y + 7 = 0$ (b) $4x - 3y + 24 = 0$
(c) $3x - 4y + 25 = 0$ (d) $4x + 3y = 0$
12. If the straight line, $2x - 3y + 17 = 0$ is perpendicular to the line passing through the points $(7, 17)$ and $(15, \beta)$, then β equals
(2019 Main, 12 Jan I)
- (a) $\frac{35}{3}$ (b) -5 (c) $-\frac{35}{3}$ (d) 5
13. If in a parallelogram $ABDC$, the coordinates of A, B and C are respectively $(1, 2), (3, 4)$ and $(2, 5)$, then the equation of the diagonal AD is
(2019 Main, 11 Jan II)
- (a) $3x + 5y - 13 = 0$ (b) $3x - 5y + 7 = 0$
(c) $5x - 3y + 1 = 0$ (d) $5x + 3y - 11 = 0$
14. The tangent to the curve, $y = xe^{x^2}$ passing through the point $(1, e)$ also passes through the point
(2019 Main, 10 Jan II)
- (a) $\left(\frac{4}{3}, 2e\right)$ (b) $(3, 6e)$ (c) $(2, 3e)$ (d) $\left(\frac{5}{3}, 2e\right)$
15. Two sides of a parallelogram are along the lines, $x + y = 3$ and $x - y + 3 = 0$. If its diagonals intersect at $(2, 4)$, then one of its vertex is
(2019 Main, 10 Jan II)
- (a) $(3, 6)$ (b) $(2, 6)$
(c) $(2, 1)$ (d) $(3, 5)$
16. The shortest distance between the point $\left(\frac{3}{2}, 0\right)$ and the curve $y = \sqrt{x}, (x > 0)$, is
(2019 Main, 10 Jan I)
- (a) $\frac{3}{2}$ (b) $\frac{5}{4}$ (c) $\frac{\sqrt{3}}{2}$ (d) $\frac{\sqrt{5}}{2}$
17. If the line $3x + 4y - 24 = 0$ intersects the X -axis at the point A and the Y -axis at the point B , then the incentre of the triangle OAB , where O is the origin, is
(2019 Main, 10 Jan I)
- (a) $(4, 3)$ (b) $(3, 4)$
(c) $(4, 4)$ (d) $(2, 2)$
18. A point P moves on the line $2x - 3y + 4 = 0$. If $Q(1, 4)$ and $R(3, -2)$ are fixed points, then the locus of the centroid of ΔPQR is a line
(2019 Main, 10 Jan I)
- (a) with slope $\frac{2}{3}$ (b) with slope $\frac{3}{2}$
(c) parallel to Y -axis (d) parallel to X -axis
19. A straight line through a fixed point $(2, 3)$ intersects the coordinate axes at distinct points P and Q . If O is the origin and the rectangle $OPRQ$ is completed, then the locus of R is
(2018 Main)
- (a) $3x + 2y = 6$ (b) $2x + 3y = xy$
(c) $3x + 2y = xy$ (d) $3x + 2y = 6xy$
20. Let k be an integer such that the triangle with vertices $(k, -3k), (5, k)$ and $(-k, 2)$ has area 28 sq units. Then, the orthocentre of this triangle is at the point
(2017 Main)
- (a) $\left(2, -\frac{1}{2}\right)$ (b) $\left(1, \frac{3}{4}\right)$ (c) $\left(1, -\frac{3}{4}\right)$ (d) $\left(2, \frac{1}{2}\right)$
21. Let a, b, c and d be non-zero numbers. If the point of intersection of the lines $4ax + 2ay + c = 0$ and $5bx + 2by + d = 0$ lies in the fourth quadrant and is equidistant from the two axes, then
(2014 Main)
- (a) $2bc - 3ad = 0$ (b) $2bc + 3ad = 0$
(c) $2ad - 3bc = 0$ (d) $3bc + 2ad = 0$
22. If PS is the median of the triangle with vertices $P(2, 2), Q(6, -1)$ and $R(7, 3)$, then equation of the line passing through $(1, -1)$ and parallel to PS is
(2014 Main, 2000)
- (a) $4x - 7y - 11 = 0$ (b) $2x + 9y + 7 = 0$
(c) $4x + 7y + 3 = 0$ (d) $2x - 9y - 11 = 0$
23. The x -coordinate of the incentre of the triangle that has the coordinates of mid-points of its sides as $(0, 1), (1, 1)$ and $(1, 0)$ is
(2013 Main)
- (a) $2 + \sqrt{2}$ (b) $2 - \sqrt{2}$ (c) $1 + \sqrt{2}$ (d) $1 - \sqrt{2}$
24. A straight line L through the point $(3, -2)$ is inclined at an angle 60° to the line $\sqrt{3}x + y = 1$. If L also intersects the X -axis, then the equation of L is
(2011)
- (a) $y + \sqrt{3}x + 2 - 3\sqrt{3} = 0$ (b) $y - \sqrt{3}x + 2 + 3\sqrt{3} = 0$
(c) $\sqrt{3}y - x + 3 + 2\sqrt{3} = 0$ (d) $\sqrt{3}y + x - 3 + 2\sqrt{3} = 0$
25. The locus of the orthocentre of the triangle formed by the lines $(1 + p)x - py + p(1 + p) = 0$, $(1 + q)x - qy + q(1 + q) = 0$ and $y = 0$, where $p \neq q$, is
(2009)
- (a) a hyperbola (b) a parabola
(c) an ellipse (d) a straight line
26. Let $O(0, 0), P(3, 4)$ and $Q(6, 0)$ be the vertices of a ΔOPQ . The point R inside the ΔOPQ is such that the triangles OPR, PQR and OQR are of equal area. The coordinates of R are
(2007, 3M)
- (a) $\left(\frac{4}{3}, 3\right)$ (b) $\left(3, \frac{2}{3}\right)$ (c) $\left(3, \frac{4}{3}\right)$ (d) $\left(\frac{4}{3}, \frac{2}{3}\right)$
27. Orthocentre of triangle with vertices $(0, 0), (3, 4)$ and $(4, 0)$ is
(2003, 2M)
- (a) $\left(3, \frac{5}{4}\right)$ (b) $(3, 12)$ (c) $\left(3, \frac{3}{4}\right)$ (d) $(3, 9)$
28. The number of integer values of m , for which the x -coordinate of the point of intersection of the lines $3x + 4y = 9$ and $y = mx + 1$ is also an integer, is
(2001, 1M)
- (a) 2 (b) 0 (c) 4 (d) 1
29. A straight line through the origin O meets the parallel lines $4x + 2y = 9$ and $2x + y + 6 = 0$ at points P and Q respectively. Then, the point O divides the segment PQ in the ratio
(2000, 1M)
- (a) 1:2 (b) 3:4 (c) 2:1 (d) 4:3
30. The incentre of the triangle with vertices $(1, \sqrt{3}), (0, 0)$ and $(2, 0)$ is
(2000, 2M)
- (a) $\left(1, \frac{\sqrt{3}}{2}\right)$ (b) $\left(\frac{2}{3}, \frac{1}{\sqrt{3}}\right)$ (c) $\left(\frac{2}{3}, \frac{\sqrt{3}}{2}\right)$ (d) $\left(1, \frac{1}{\sqrt{3}}\right)$

31. If A_0, A_1, A_2, A_3, A_4 and A_5 be a regular hexagon inscribed in a circle of unit radius. Then, the product of the lengths of the line segments A_0A_1, A_0A_2 and A_0A_4 is (1998, 2M)

(a) $3/4$ (b) $3\sqrt{3}$ (c) 3 (d) $\frac{3\sqrt{3}}{2}$

32. If the vertices P, Q, R of a ΔPQR are rational points, which of the following points of the ΔPQR is/are always rational point(s) (1998, 2M)

(a) centroid (b) incentre
(c) circumcentre (d) orthocentre

(A rational point is a point both of whose coordinates are rational numbers)

33. If $P(1, 2), Q(4, 6), R(5, 7)$ and $S(a, b)$ are the vertices of a parallelogram $PQRS$, then (1998, 2M)

(a) $a = 2, b = 4$ (b) $a = 3, b = 4$
(c) $a = 2, b = 3$ (d) $a = 3, b = 5$

34. The diagonals of a parallelogram $PQRS$ are along the lines $x + 3y = 4$ and $6x - 2y = 7$. Then, $PQRS$ must be a (1998, 2M)

(a) rectangle (b) square
(c) cyclic quadrilateral (d) rhombus

35. The graph of the function $\cos x \cos(x + 2) - \cos^2(x + 1)$ is (1997, 2M)

(a) a straight line passing through $(0, -\sin^2 1)$ with slope 2
(b) a straight line passing through $(0, 0)$
(c) a parabola with vertex $(1, -\sin^2 1)$
(d) a straight line passing through the point $\left(\frac{\pi}{2}, -\sin^2 1\right)$ and parallel to the X -axis

36. The orthocentre of the triangle formed by the lines $xy = 0$ and $x + y = 1$, is (1995, 2M)

(a) $\left(\frac{1}{2}, \frac{1}{2}\right)$ (b) $\left(\frac{1}{3}, \frac{1}{3}\right)$ (c) $(0, 0)$ (d) $\left(\frac{1}{4}, \frac{1}{4}\right)$

37. If the sum of the distance of a point from two perpendicular lines in a plane is 1, then its locus is (1992, 2M)

(a) square (b) circle
(c) straight line (d) two intersecting lines

38. Line L has intercepts a and b on the coordinate axes. When, the axes are rotated through a given angle, keeping the origin fixed, the same line L has intercepts p and q , then (1990, 2M)

(a) $a^2 + b^2 = p^2 + q^2$ (b) $\frac{1}{a^2} + \frac{1}{b^2} = \frac{1}{p^2} + \frac{1}{q^2}$
(c) $a^2 + p^2 = b^2 + q^2$ (d) $\frac{1}{a^2} + \frac{1}{p^2} = \frac{1}{b^2} + \frac{1}{q^2}$

39. If $P = (1, 0), Q = (-1, 0)$ and $R = (2, 0)$ are three given points, then locus of the points satisfying the relation $SQ^2 + SR^2 = 2SP^2$, is (1988, 2M)

(a) a straight line parallel to X -axis
(b) a circle passing through the origin
(c) a circle with the centre at the origin
(d) a straight line parallel to Y -axis

40. The point $(4, 1)$ undergoes the following three transformations successively

I. Reflection about the line $y = x$.

II. Transformation through a distance 2 units along the positive direction of X -axis.

III. Rotation through an angle $\frac{\pi}{4}$ about the origin in the

counter clockwise direction.

Then, the final position of the point is given by the coordinates (1980, 1M)

(a) $\left(\frac{1}{\sqrt{2}}, \frac{7}{\sqrt{2}}\right)$ (b) $(-\sqrt{2}, 7\sqrt{2})$
(c) $\left(-\frac{1}{\sqrt{2}}, \frac{7}{\sqrt{2}}\right)$ (d) $(\sqrt{2}, 7\sqrt{2})$

41. The points $(-a, -b), (0, 0), (a, b)$ and (a^2, a^3) are (1979, 2M)

(a) collinear
(b) vertices of a rectangle
(c) vertices of a parallelogram
(d) None of the above

Objective Questions II

(One or more than one correct option)

42. Let $a, \lambda, \mu \in R$. Consider the system of linear equations $ax + 2y = \lambda$ and $3x - 2y = \mu$.

Which of the following statement(s) is/are correct?

(2016 Adv.)

(a) If $a = -3$, then the system has infinitely many solutions for all values of λ and μ
(b) If $a \neq -3$, then the system has a unique solution for all values of λ and μ
(c) If $\lambda + \mu = 0$, then the system has infinitely many solutions for $a = -3$
(d) If $\lambda + \mu \neq 0$, then the system has no solution for $a = -3$

43. For $a > b > c > 0$, the distance between $(1, 1)$ and the point of intersection of the lines $ax + by + c = 0$ and $bx + ay + c = 0$ is less than $2\sqrt{2}$. Then, (2014 Adv.)

(a) $a + b - c > 0$ (b) $a - b + c < 0$
(c) $a - b + c > 0$ (d) $a + b - c < 0$

44. All points lying inside the triangle formed by the points $(1, 3), (5, 0)$ and $(-1, 2)$ satisfy (1986, 2M)

(a) $3x + 2y \geq 0$ (b) $2x + y - 13 \geq 0$
(c) $2x - 3y - 12 \leq 0$ (d) $-2x + y \geq 0$

Fill in the Blanks

45. Let the algebraic sum of the perpendicular distance from the points $(2, 0), (0, 2)$ and $(1, 1)$ to a variable straight line be zero, then the line passes through a fixed point whose coordinates are... (1991, 2M)

46. The orthocentre of the triangle formed by the lines $x + y = 1, 2x + 3y = 6$ and $4x - y + 4 = 0$ lies in quadrant number... (1985, 2M)

47. If a, b and c are in AP, then the straight line $ax + by + c = 0$ will always pass through a fixed point whose coordinates are (...). (1984, 2M)

48. $y = 10^x$ is the reflection of $y = \log_{10} x$ in the line whose equation is (1984, 2M)

382 Straight Line and Pair of Straight Lines

True/False

49. The lines $2x + 3y + 19 = 0$ and $9x + 6y - 17 = 0$ cut the coordinate axes in concyclic points. (1988, 1M)
50. No tangent can be drawn from the point $(5/2, 1)$ to the circumcircle of the triangle with vertices $(1, \sqrt{3})$, $(1, -\sqrt{3})$ and $(3, \sqrt{3})$. (1985, 1M)
51. The straight line $5x + 4y = 0$ passes through the point of intersection of the straight lines $x + 2y - 10 = 0$ and $2x + y + 5 = 0$. (1983, 1M)

Analytical & Descriptive Questions

52. A straight line L through the origin meets the line $x + y = 1$ and $x + y = 3$ at P and Q respectively. Through P and Q two straight lines L_1 and L_2 are drawn, parallel to $2x - y = 5$ and $3x + y = 5$, respectively. Lines L_1 and L_2 intersect at R , show that the locus of R as L varies, is a straight line. (2002, 5M)
53. A straight line L with negative slope passes through the point $(8, 2)$ and cuts the positive coordinate axes at points P and Q . Find the absolute minimum value of $OP + OQ$, as L varies, where O is the origin. (2002, 5M)
54. For points $P = (x_1, y_1)$ and $Q = (x_2, y_2)$ of the coordinate plane, a new distance $d(P, Q)$ is defined by $d(P, Q) = |x_1 - x_2| + |y_1 - y_2|$.
Let $O = (0, 0)$ and $A = (3, 2)$. Prove that the set of points in the first quadrant which are equidistant (with respect to the new distance) from O and A consists of the union of a line segment of finite length and an infinite ray. Sketch this set in a labelled diagram. (2000, 10M)
55. A rectangle $PQRS$ has its side PQ parallel to the line $y = mx$ and vertices PQ and S on the lines $y = a$, $x = b$ and $x = -b$, respectively. Find the locus of the vertex R . (1996, 2M)
56. A line through $A(-5, -4)$ meets the line $x + 3y + 2 = 0$, $2x + y + 4 = 0$ and $x - y - 5 = 0$ at the points B, C and D respectively. If $(15/AB)^2 + (10/AC)^2 = (6/AD)^2$, find the equation of the line. (1993, 5M)
57. Determine all values of α for which the point (α, α^2) lies inside the triangles formed by the lines $2x + 3y - 1 = 0$, $x + 2y - 3 = 0$, $5x - 6y - 1 = 0$ (1992, 6M)
58. Find the equations of the line passing through the point $(2, 3)$ and making intercept of length 3 unit between the lines $y + 2x = 2$ and $y + 2x = 5$. (1991, 4M)
59. Straight lines $3x + 4y = 5$ and $4x - 3y = 15$ intersect at the point A . Points B and C are chosen on these two lines such that $AB = AC$. Determine the possible equations of the line BC passing through the point $(1, 2)$. (1990, 4M)
60. A line cuts the X -axis at $A(7, 0)$ and the Y -axis at $B(0, -5)$. A variable line PQ is drawn perpendicular to AB cutting the X -axis in P and the Y -axis in Q . If AQ and BP intersect at R , find the locus of R . (1990, 4M)

61. Let ABC be a triangle with $AB = AC$. If D is mid point of BC , the foot of the perpendicular drawn from D to AC and F the mid-point of DE . Prove that AF is perpendicular to BE . (1989, 5M)
62. The equations of the perpendicular bisectors of the sides AB and AC of a $\triangle ABC$ are $x - y + 5 = 0$ and $x + 2y = 0$, respectively. If the point A is $(1, -2)$, find the equation of the line BC . (1986, 5M)
63. One of the diameters of the circle circumscribing the rectangle $ABCD$ is $4y = x + 7$. If A and B are the points $(-3, 4)$ and $(5, 4)$ respectively, then find the area of rectangle. (1985, 3M)
64. Two sides of a rhombus $ABCD$ are parallel to the lines $y = x + 2$ and $y = 7x + 3$. If the diagonals of the rhombus intersect at the point $(1, 2)$ and the vertex A is on the Y -axis, find possible coordinates of A . (1985, 5M)
65. Two equal sides of an isosceles triangle are given by the equations $7x - y + 3 = 0$ and $x + y - 3 = 0$ and its third side passes through the point $(1, -10)$. Determine the equation of the third side. (1984, 4M)
66. The vertices of a triangle are $[at_1t_2, a(t_1 + t_2)]$, $[at_2t_3, a(t_2 + t_3)]$, $[at_3t_1, a(t_3 + t_1)]$.
Find the orthocentre of the triangle. (1983, 3M)
67. The ends A, B of a straight line segment of constant length c slide upon the fixed rectangular axes OX, OY respectively. If the rectangle $OAPB$ be completed, then show that the locus of the foot of the perpendicular drawn from P to AB is
$$x^{2/3} + y^{2/3} = c^{2/3}$$
 (1983, 2M)
68. The points $(1, 3)$ and $(5, 1)$ are two opposite vertices of a rectangle. The other two vertices lie on the line $y = 2x + c$. Find c and the remaining vertices. (1981, 4M)
69. Two vertices of a triangle are $(5, -1)$ and $(-2, 3)$. If the orthocentre of the triangle is the origin, find the coordinates of the third vertex. (1978, 3M)
70. One side of a rectangle lies along the line $4x + 7y + 5 = 0$. Two of its vertices are $(-3, 1)$ and $(1, 1)$. Find the equations of the other three sides. (1978, 3M)

Integer & Numerical Answer Type Questions

71. Let $A(1, 0)$, $B(6, 2)$ and $C\left(\frac{3}{2}, 6\right)$ be the vertices of a triangle ABC . If P is a point inside the triangle ABC such that the triangles APC , APB and BPC have equal areas, then the length of the line segment PQ , where Q is the point $\left(-\frac{7}{6}, -\frac{1}{3}\right)$, is (2020 Main, 7 Jan I)
72. For a point P in the plane, let $d_1(P)$ and $d_2(P)$ be the distances of the point P from the lines $x - y = 0$ and $x + y = 0$, respectively. The area of the region R consisting of all points P lying in the first quadrant of the plane and satisfying $2 \leq d_1(P) + d_2(P) \leq 4$, is (2014 Adv.)

Topic 2 Angle between Straight Lines and Equation of Angle Bisector

Objective Questions I (Only one correct option)

1. A ray of light coming from the point $(2, 2\sqrt{3})$ is incident at an angle 30° on the line $x = 1$ at the point A . The ray gets reflected on the line $x = 1$ and meets X -axis at the point B . Then, the line AB passes through the point
(2020 Main, 6 Sep I)

- (a) $\left(3, -\frac{1}{\sqrt{3}}\right)$
 (b) $\left(4, -\frac{\sqrt{3}}{2}\right)$
 (c) $(3, -\sqrt{3})$
 (d) $(4, -\sqrt{3})$

Objective Questions II

(One or more than one correct option)

2. A ray of light along $x + \sqrt{3}y = \sqrt{3}$ gets reflected upon reaching X -axis, the equation of the reflected ray is
(2013 Main)

- (a) $y = x + \sqrt{3}$ (b) $\sqrt{3}y = x - \sqrt{3}$
 (c) $y = \sqrt{3}x - \sqrt{3}$ (d) $\sqrt{3}y = x - 1$

3. Consider three points

$$P = \{-\sin(\beta - \alpha) - \cos \beta\}, Q = \{\cos(\beta - \alpha), \sin \beta\}$$

$$\text{and } R = \{\cos(\beta - \alpha + \theta) \sin(\beta - \theta)\},$$

where $0 < \alpha, \beta, \theta < \frac{\pi}{4}$. Then,

(2008, 4M)

- (a) P lies on the line segment RQ
 (b) Q lies on the line segment PR
 (c) R lies on the line segment QP
 (d) P, Q, R are non-collinear
4. Let $P = (-1, 0)$, and $Q(0, 0)$ and $R = (3, 3\sqrt{3})$ be three point. Then, the equation of the bisector of the angle PQR is
(2001, 1M)

- (a) $\frac{\sqrt{3}}{2}x + y = 0$ (b) $x + \sqrt{3}y = 0$
 (c) $\sqrt{3}x + y = 0$ (d) $x + \frac{\sqrt{3}}{2}y = 0$

Assertion and Reason

For the following questions choose the correct answer from the codes (a), (b), (c) and (d) defined as follows.

- (a) Statement I is true, Statement II is also true; Statement II is the correct explanation of Statement I
 (b) Statement I is true, Statement II is also true; Statement II is not the correct explanation of Statement I
 (c) Statement I is true; Statement II is false
 (d) Statement I is false; Statement II is true
5. Lines $L_1 : y - x = 0$ and $L_2 : 2x + y = 0$ intersect the line $L_3 : y + 2 = 0$ at P and Q , respectively. The bisector of the acute angle between L_1 and L_2 intersects L_3 at R .

Statement I The ratio $PR : RQ$ equals $2\sqrt{2} : \sqrt{5}$.

Because

Statement II In any triangle, bisector of an angle divides the triangle into two similar triangles. (2007, 3M)

Fill in the Blank

6. The vertices of a triangle are $A(-1, -7)$, $B(5, 1)$ and $C(1, 4)$. The equation of the bisector of the angle ABC is...
(1993, 2M)

Analytical & Descriptive Questions

7. The area of the triangle formed by the intersection of line parallel to X -axis and passing through (h, k) with the lines $y = x$ and $x + y = 2$ is $4h^2$. Find the locus of point P .
(2005)
8. Find the equation of the line which bisects the obtuse angle between the lines $x - 2y + 4 = 0$ and $4x - 3y + 2 = 0$.
(1993, 2M)
9. Lines $L_1 \equiv ax + by + c = 0$ and $L_2 \equiv lx + my + n = 0$ intersect at the point P and makes an angle θ with each other. Find the equation of a line L different from L_2 which passes through P and makes the same angle θ with L_1 .
(1988, 5M)

Topic 3 Area and Family of Concurrent Lines

Objective Questions I (Only one correct option)

1. A triangle has a vertex at $(1, 2)$ and the mid-points of the two sides through it are $(-1, 1)$ and $(2, 3)$. Then, the centroid of this triangle is
(2019 Main, 12 April II)

- (a) $\left(1, \frac{7}{3}\right)$ (b) $\left(\frac{1}{3}, 2\right)$
 (c) $\left(\frac{1}{3}, 1\right)$ (d) $\left(\frac{1}{3}, \frac{5}{3}\right)$

2. Consider the set of all lines $px + qy + r = 0$ such that $3p + 2q + 4r = 0$. Which one of the following statements is true?
(2019 Main, 9 Jan I)

- (a) Each line passes through the origin.
 (b) The lines are concurrent at the point $\left(\frac{3}{4}, \frac{1}{2}\right)$
 (c) The lines are all parallel
 (d) The lines are not concurrent

384 Straight Line and Pair of Straight Lines

3. Two sides of a rhombus are along the lines, $x - y + 1 = 0$ and $7x - y - 5 = 0$. If its diagonals intersect at $(-1, -2)$, then which one of the following is a vertex of this rhombus? (2016 Main)
- (a) $(-3, -9)$ (b) $(-3, -8)$
 (c) $(\frac{1}{3}, -\frac{8}{3})$ (d) $(-\frac{10}{3}, -\frac{7}{3})$
4. Area of the parallelogram formed by the lines $y = mx$, $y = mx + 1$, $y = nx$ and $y = nx + 1$ equals (2001, 1M)
- (a) $\frac{|m+n|}{(m-n)^2}$ (b) $\frac{2}{|m+n|}$
 (c) $\frac{1}{|m+n|}$ (d) $\frac{1}{|m-n|}$
5. The points $(0, \frac{8}{3})$, $(1, 3)$ and $(82, 30)$ are vertices of (1986, 2M)
- (a) an obtuse angled triangle
 (b) an acute angled triangle
 (c) a right angled triangle
 (d) None of the above
6. The straight lines $x + y = 0$, $3x + y - 4 = 0$, $x + 3y - 4 = 0$ form a triangle which is (1983, 1M)
- (a) isosceles
 (b) equilateral
 (c) right angled
 (d) None of the above
7. Given the four lines with the equations $x + 2y - 3 = 0$, $3x + 4y - 7 = 0$, $2x + 3y - 4 = 0$, $4x + 5y - 6 = 0$, then (1980, 1M)
- (a) they are all concurrent
 (b) they are the sides of a quadrilateral
 (c) only three lines are concurrent
 (d) None of the above

Objective Question II

(One or more than one correct option)

8. Three lines $px + qy + r = 0$, $qx + ry + p = 0$ and $rx + py + q = 0$ are concurrent, if (1985, 2M)
- (a) $p + q + r = 0$ (b) $p^2 + q^2 + r^2 = pr + rq$
 (c) $p^3 + q^3 + r^3 = 3pqr$ (d) None of these

Match the Columns

Match the conditions/expressions in Column I with statement in Column II.

9. Consider the lines given by

$$L_1 : x + 3y - 5 = 0, \quad L_2 : 3x - ky - 1 = 0, \\ L_3 : 5x + 2y - 12 = 0$$

Column I		Column II	
(A)	L_1, L_2, L_3 are concurrent, if	(p)	$k = -9$
(B)	One of L_1, L_2, L_3 is parallel to at least one of the other two, if	(q)	$k = -\frac{6}{5}$
(C)	L_1, L_2, L_3 form a triangle, if	(r)	$k = \frac{5}{6}$
(D)	L_1, L_2, L_3 do not form a triangle, if	(s)	$k = 5$

Fill in the Blank

10. The set of lines $ax + by + c = 0$, where $3a + 2b + 4c = 0$ is concurrent at the point... (1982, 2M)

True/False

11. If $\begin{vmatrix} x_1 & y_1 & 1 \\ x_2 & y_2 & 1 \\ x_3 & y_3 & 1 \end{vmatrix} = \begin{vmatrix} a_1 & b_1 & 1 \\ a_2 & b_2 & 1 \\ a_3 & b_3 & 1 \end{vmatrix}$, then the two triangles with vertices (x_1, y_1) , (x_2, y_2) , (x_3, y_3) and (a_1, b_1) , (a_2, b_2) , (a_3, b_3) must be congruent. (1985, 1M)

Analytical & Descriptive Questions

12. Using coordinate geometry, prove that the three altitudes of any triangle are concurrent. (1998, 8M)
13. The coordinates of A, B, C are $(6, 3)$, $(-3, 5)$, $(4, -2)$ respectively and P is any point (x, y) . Show that the ratio of the areas of the triangles ΔPBC and ΔABC is $\left| \frac{x + y - 2}{7} \right|$. (1983, 2M)
14. A straight line L is perpendicular to the line in $5x - y = 1$. The area of the triangle formed by the line L and the coordinate axes is 5. Find the equation of the line L . (1980, 3M)

Topic 4 Homogeneous Equation of Pair of Straight Lines

Objective Questions I (Only one correct option)

1. Let a and b be non-zero and real numbers. Then, the equation $(ax^2 + by^2 + c)(x^2 - 5xy + 6y^2) = 0$ represents (2008, 3M)
- (a) four straight lines, when $c = 0$ and a, b are of the same sign
 (b) two straight lines and a circle, when $a = b$ and c is of sign opposite to that of a
 (c) two straight lines and a hyperbola, when a and b are of the same sign and c is of sign opposite to that of a
 (d) a circle and an ellipse, when a and b are of the same sign and c is of sign opposite to that of a

2. Area of triangle formed by the lines $x + y = 3$ and angle bisectors of the pair of straight lines $x^2 - y^2 + 2y = 1$ is (2004, 2M)
- (a) 2 sq units (b) 4 sq units
(c) 6 sq units (d) 8 sq units

Analytical & Descriptive Question

3. Show that all chords of curve $3x^2 - y^2 - 2x + 4y = 0$, which subtend a right angle at the origin pass through a fixed point. Find the coordinates of the point. (1991, 4M)

Topic 5 General Equation of Pair of Straight Lines

Objective Question I (Only one correct option)

1. Let PQR be a right angled isosceles triangle, right angled at $P(2, 1)$. If the equation of the line QR is $2x + y = 3$, then the equation representing the pair of lines PQ and PR is (1999, 2M)

- (a) $3x^2 - 3y^2 + 8xy + 20x + 10y + 25 = 0$
(b) $3x^2 - 3y^2 + 8xy - 20x - 10y + 25 = 0$
(c) $3x^2 - 3y^2 + 8xy + 10x + 15y + 20 = 0$
(d) $3x^2 - 3y^2 - 8xy - 10x - 15y - 20 = 0$

Answers

Topic 1

1. (a) 2. (d) 3. (d) 4. (b)
5. (c) 6. (d) 7. (c) 8. (c)
9. (c) 10. (c) 11. (b) 12. (d)
13. (c) 14. (a) 15. (a) 16. (d)
17. (d) 18. (a) 19. (c) 20. (d)
21. (c) 22. (b) 23. (b) 24. (b)
25. (d) 26. (c) 27. (c) 28. (a)
29. (b) 30. (d) 31. (c) 32. (a)
33. (c) 34. (d) 35. (d) 36. (c)
37. (a) 38. (b) 39. (d) 40. (c)
41. (a) 42. (b, c, d) 43. (a, c) 44. (a, c)
45. (1, 1) 46. Ist 47. (1, -2) 48. ($y = x$)
49. True 50. True 51. True
53. ($OP + OQ = 18$)
55. $(m^2 - 1)x - my + b(m^2 + 1) + am = 0$
56. $2x + 3y + 22 = 0$ 57. $-\frac{3}{2} < \alpha < -1 \cup \frac{1}{2} < \alpha < 1$
58. $x = 2$ and $3x + 4y = 18$
59. $x - 7y + 13 = 0$ and $7x + y - 9 = 0$
60. $x^2 + y^2 - 7x + 5y = 0$ 62. $14x + 23y - 40 = 0$
63. 32 sq units 64. $\left(0, \frac{5}{2}\right)$ or $(0, 0)$
65. $x - 3y - 31 = 0$ or $3x + y + 7 = 0$

66. $[(-a, a(t_1 + t_2 + t_3 + t_1t_2t_3))]$ 68. $c = -4, (4, 4), (2, 0)$
69. $(-4, -7)$
70. $7x - 4y + 25 = 0, 4x + 7y = 11 = 0, 7x - 4y - 3 = 0$
71. (5)
72. 6 sq units

Topic 2

1. (c) 2. (b) 3. (d) 4. (c)
5. (c) 6. $7y = x + 2$ 7. $2x = \pm(y - 1)$
8. $(4 + \sqrt{5})x - (2\sqrt{5} + 3)y + (4\sqrt{5} + 2) = 0$
9. $2(al + bm)(ax + by + c) - (a^2 + b^2)(lx + my + n) = 0$

Topic 3

1. (b) 2. (b) 3. (c) 4. (d)
5. (d) 6. (a) 7. (c) 8. (a, c)
9. $A \rightarrow s; B \rightarrow p, q; C \rightarrow r; D \rightarrow p, q, s$
10. $\left(\frac{3}{4}, \frac{1}{2}\right)$ 11. False
14. $x + 5y = \pm 5\sqrt{2}$

Topic 4

1. (b) 2. (a)
3. (1, -2)

Topic 5

1. (b)

Hints & Solutions

Topic 1 Various Forms of Straight Line

1. According to the question, as points $(1, 2)$ and $(\sin \theta, \cos \theta)$, $\theta \in (0, \pi)$, lie on the same side of the line $x + y = 1$, so $(1 + 2 - 1)(\sin \theta + \cos \theta - 1) > 0$

$$\begin{aligned} \Rightarrow \sin \theta + \cos \theta &> 1 \\ \Rightarrow \frac{1}{\sqrt{2}} \sin \theta + \frac{1}{\sqrt{2}} \cos \theta &> \frac{1}{\sqrt{2}} \Rightarrow \sin\left(\frac{\pi}{4} + \theta\right) > \frac{1}{\sqrt{2}} \\ \Rightarrow 2n\pi + \frac{\pi}{4} < \frac{\pi}{4} + \theta < 2n\pi + \frac{3\pi}{4}, n \in I. \\ \Rightarrow 2n\pi < \theta < 2n\pi + \frac{\pi}{2} \end{aligned}$$

As $\theta \in (0, \pi)$, So for $n = 0$, $\theta \in \left(0, \frac{\pi}{2}\right)$

Hence, option (a) is correct.

2. According to the question, we have the following figure.

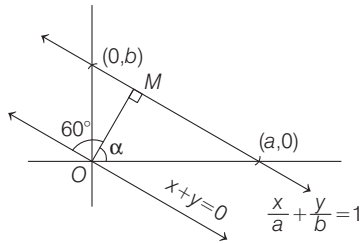

Let θ be the inclination of the line $x + y = 0$. Then,

$$\begin{aligned} \tan \theta &= -1 = \tan(180^\circ - 45^\circ) \\ \Rightarrow \tan \theta &= \tan 135^\circ \Rightarrow \theta = 135^\circ \\ \Rightarrow \alpha + 60^\circ &= 135^\circ \Rightarrow \alpha = 75^\circ \end{aligned}$$

Since, line L having perpendicular distance $OM = 4$.

So, equation of the line ' L ' is

$$\begin{aligned} x \cos \alpha + y \sin \alpha &= 4 \\ \Rightarrow x \cos 75^\circ + y \sin 75^\circ &= 4 \\ \Rightarrow x \cos(45^\circ + 30^\circ) + y \sin(45^\circ + 30^\circ) &= 4 \\ \Rightarrow x \left\{ \frac{\sqrt{3}}{2\sqrt{2}} - \frac{1}{2\sqrt{2}} \right\} + y \left\{ \frac{\sqrt{3}}{2\sqrt{2}} + \frac{1}{2\sqrt{2}} \right\} &= 4 \\ \Rightarrow (\sqrt{3} - 1)x + y(\sqrt{3} + 1) &= 8\sqrt{2} \end{aligned}$$

3. **Key Idea** Use formulae:
 $2 \sin A \sin B = \cos(A - B) - \cos(A + B)$ and $\cos 2\theta = 1 - 2 \sin^2 \theta$

$$\begin{aligned} \text{Given equation is } y &= \sin x \sin(x + 2) - \sin^2(x + 1) \\ &= \frac{1}{2} [\cos 2 - \cos(2x + 2)] - \frac{1}{2} [1 - \cos(2x + 2)] \\ & \quad [\because 2 \sin A \sin B = \cos(A - B) - \cos(A + B) \\ & \quad \text{and } \cos 2\theta = 1 - 2 \sin^2 \theta \Rightarrow 2 \sin^2 \theta = 1 - \cos 2\theta] \\ &= \frac{1}{2} \cos 2 - \frac{1}{2} \cos(2x + 2) - \frac{1}{2} + \frac{1}{2} \cos(2x + 2) \\ &= \frac{1}{2} (\cos(2) - 1) = -\frac{1}{2} (2 \sin^2(1)) \\ &= -\sin^2(1) < 0 \Rightarrow y < 0 \end{aligned}$$

and as we know that $y < 0$, is in third and fourth quadrants only.

4. Since, equation of a line parallel to line $ax + by + c = 0$ is $ax + by + k = 0$
 \therefore Equation of line parallel to line

$$4x - 3y + 2 = 0 \text{ is } 4x - 3y + k = 0 \quad \dots(i)$$

Now, distance of line (i) from the origin is

$$\frac{|k|}{\sqrt{4^2 + 3^2}} = \frac{3}{5}$$

[as per question's requirement]

$$\Rightarrow |k| = 3$$

$$\Rightarrow k = \pm 3$$

So, possible lines having equation, either $4x - 3y + 3 = 0$ or $4x - 3y - 3 = 0$

Now, from the given options the point $\left(-\frac{1}{4}, \frac{2}{3}\right)$ lies on

the line $4x - 3y + 3 = 0$.

5. The given inequalities are

$$|x - y| \leq 2 \text{ and } |x + y| \leq 2.$$

On drawing, the above inequalities, we get a square

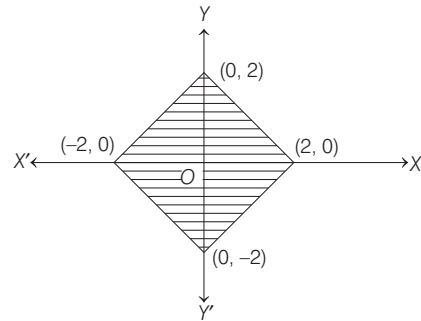

Now, the area of shaded region is equal to the area of a square having side length $\sqrt{(2 - 0)^2 + (0 - 2)^2} = 2\sqrt{2}$ units.

6. **Key Idea**

- (i) If lines are perpendicular to each other, then product of their slopes is -1 , i.e. $m_1 m_2 = -1$
 (ii) Distance between two points (x_1, y_1) and (x_2, y_2)
 $= \sqrt{(x_2 - x_1)^2 + (y_2 - y_1)^2}$

Given, lines $x + (a - 1)y = 1$
 and $2x + a^2 y = 1$, where $a \in \mathbb{R} - \{0, 1\}$
 are perpendicular to each other

$$\therefore \left(-\frac{1}{a-1}\right) \times \left(-\frac{2}{a^2}\right) = -1$$

[\because If lines are perpendicular, then product of their slopes is -1]

$$\Rightarrow a^2(a - 1) = -2 \Rightarrow a^3 - a^2 + 2 = 0$$

$$\Rightarrow (a + 1)(a^2 - 2a + 2) = 0 \Rightarrow a = -1$$

∴ Equation of lines are

$$x - 2y = 1 \quad \dots(i)$$

and $2x + y = 1 \quad \dots(ii)$

On solving Eq. (i) and Eq. (ii), we get

$$x = \frac{3}{5} \text{ and } y = -\frac{1}{5}$$

∴ Point of intersection of the lines (i) and (ii) is $P\left(\frac{3}{5}, -\frac{1}{5}\right)$.

Now, required distance of the point $P\left(\frac{3}{5}, -\frac{1}{5}\right)$ from

$$\text{origin} = \sqrt{\frac{9}{25} + \frac{1}{25}} = \sqrt{\frac{10}{25}} = \sqrt{\frac{2}{5}}$$

7. Let the slope of line is m , which is passing through $P(2, 3)$.

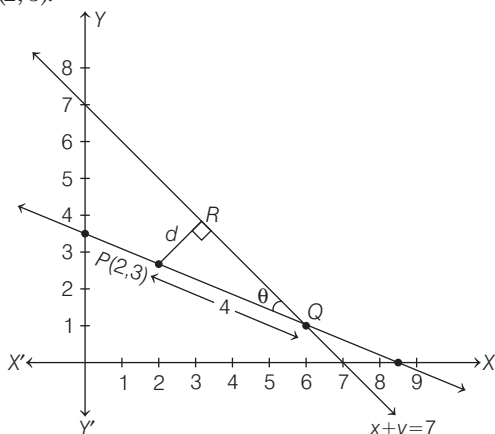

Since, the distance of a point (x_1, y_1) from the line

$$ax + by + c = 0 \text{ is } d = \frac{|ax_1 + by_1 + c|}{\sqrt{a^2 + b^2}}$$

∴ The distance of a point $P(2, 3)$ from the line $x + y - 7 = 0$, is

$$d = \frac{|2 + 3 - 7|}{\sqrt{1+1}} = \frac{2}{\sqrt{2}} = \sqrt{2}$$

Now, in ΔPRQ ,

$$QR = \sqrt{16 - d^2} = \sqrt{16 - 2} = \sqrt{14}$$

$$\therefore \tan \theta = \frac{d}{QR} = \frac{\sqrt{2}}{\sqrt{14}} = \frac{1}{\sqrt{7}} = \frac{|m+1|}{|1-m|} \left[\because \tan \theta = \left| \frac{m_2 - m_1}{1 + m_1 m_2} \right| \right]$$

$$\Rightarrow \frac{m+1}{1-m} = \pm \frac{1}{\sqrt{7}}$$

$$\Rightarrow \frac{m+1}{1-m} = \frac{1}{\sqrt{7}} \text{ or } \frac{m+1}{1-m} = -\frac{1}{\sqrt{7}}$$

$$\Rightarrow m = \frac{1 - \sqrt{7}}{1 + \sqrt{7}} \text{ or } m = \frac{-1 - \sqrt{7}}{\sqrt{7} - 1}$$

8. Given points are $P(2, -3, 4)$, $Q(8, 0, 10)$ and $R(4, y, z)$.

Now, equation of line passing through points P and Q

$$\text{is } \frac{x-8}{6} = \frac{y-0}{3} = \frac{z-10}{6}$$

[Since equation of a line passing through two points $A(x_1, y_1, z_1)$ and $B(x_2, y_2, z_2)$ is given by

$$\left. \frac{x-x_1}{x_2-x_1} = \frac{y-y_1}{y_2-y_1} = \frac{z-z_1}{z_2-z_1} \right]$$

$$\Rightarrow \frac{x-8}{2} = \frac{y}{1} = \frac{z-10}{2} \quad \dots(i)$$

∴ Points P, Q and R are collinear, so

$$\frac{4-8}{2} = \frac{y}{1} = \frac{z-10}{2}$$

$$\Rightarrow -2 = y = \frac{z-10}{2}$$

$$\Rightarrow y = -2 \text{ and } z = 6$$

So, point R is $(4, -2, 6)$, therefore the distance of point R from origin is

$$OR = \sqrt{16 + 4 + 36} = \sqrt{56} = 2\sqrt{14}$$

9. Given, points $(1, 2)$, $(-3, 4)$ and (h, k) are lies on line L_1 , so slope of line L_1 is

$$m_1 = \frac{4-2}{-3-1} = \frac{k-2}{h-1}$$

$$\Rightarrow m_1 = \frac{-1}{2} = \frac{k-2}{h-1} \quad \dots(i)$$

$$\Rightarrow 2(k-2) = -1(h-1)$$

$$\Rightarrow 2k - 4 = -h + 1$$

$$\Rightarrow h + 2k = 5 \quad \dots(ii)$$

and slope of line L_2 joining points (h, k) and

$$(4, 3), \text{ is } m_2 = \frac{3-k}{4-h} \quad \dots(iii)$$

Since, lines L_1 and L_2 are perpendicular to each other.

$$\therefore m_1 m_2 = -1$$

$$\Rightarrow \left(-\frac{1}{2}\right) \left(\frac{3-k}{4-h}\right) = -1 \text{ [from Eqs. (i) and (iii)]}$$

$$\Rightarrow 3 - k = 8 - 2h$$

$$\Rightarrow 2h - k = 5 \quad \dots(iv)$$

On solving Eqs. (ii) and (iv), we get

$$(h, k) = (3, 1)$$

$$\text{So, } \frac{k}{h} = \frac{3}{1} = 3$$

10. Given equation of line is $3x + 5y = 15 \quad \dots(i)$

Clearly, a point on the line (i), which is equidistance from X and Y -axes will lie on the line either $y = x$ or $y = -x$.

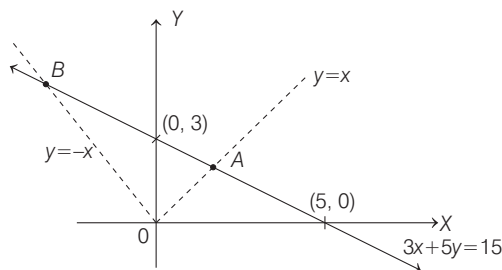

In the above figure, points A and B are on the line (i) and are equidistance from the coordinate axes.

388 Straight Line and Pair of Straight Lines

On solving line (i) and $y = x$, we get $A\left(\frac{15}{8}, \frac{15}{8}\right)$.

Similarly, on solving line (i) and $y = -x$, we get

$$B\left(-\frac{15}{2}, \frac{15}{2}\right).$$

So, the required points lie only in I and II quadrants.

11. Let the equation of required line having intercepts a and b with the axes is

$$\frac{x}{a} + \frac{y}{b} = 1 \quad \dots(i)$$

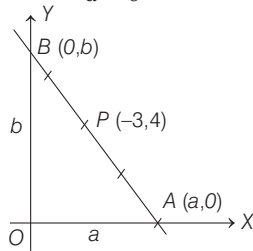

Now, according to given information,

P is the mid-point of AB

$$\therefore P = \left(\frac{a}{2}, \frac{b}{2}\right) = (-3, 4) \quad \text{[given]}$$

$$\Rightarrow (a, b) = (-6, 8)$$

On putting the value of a and b in Eq. (i), we get

$$\frac{x}{-6} + \frac{y}{8} = 1 \Rightarrow 8x - 6y = -48$$

$$\Rightarrow 4x - 3y + 24 = 0$$

12. Slope of the line $2x - 3y + 17 = 0$ is $\frac{2}{3} = m_1$, (let) and the slope of line joining the points $(7, 17)$

$$\text{and } (15, \beta) \text{ is } \frac{\beta - 17}{15 - 7} = \frac{\beta - 17}{8} = m_2 \text{ (let)}$$

According to the question, $m_1 m_2 = -1$

$$\Rightarrow \frac{2}{3} \times \frac{\beta - 17}{8} = -1 \Rightarrow \beta - 17 = -12 \Rightarrow \beta = 5.$$

13. According to given information, we have the following figure

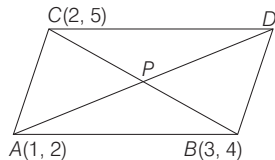

We know that, diagonals of a parallelogram intersect at mid-point.

$$\therefore P = \text{Mid-point of } BC \text{ and so, } P \equiv \left(\frac{5}{2}, \frac{9}{2}\right)$$

Now, equation of AD is.

$$(y - 2) = \frac{\frac{9}{2} - 2}{\frac{5}{2} - 1} (x - 1) \Rightarrow y - 2 = \frac{5}{3} (x - 1)$$

$$\Rightarrow 3y - 6 = 5x - 5$$

$$\Rightarrow 5x - 3y + 1 = 0$$

14. Given equation of curve is $y = xe^{x^2}$... (i)

Note that $(1, e)$ lie on the curve, so the point of contact is $(1, e)$.

Now, slope of tangent, at point $(1, e)$, to the curve (i) is

$$\left. \frac{dy}{dx} \right|_{(1, e)} = \left(x(2x)e^{x^2} + e^{x^2} \right)_{(1, e)} = 2e + e = 3e$$

Now, equation of tangent is given by

$$(y - y_1) = m(x - x_1)$$

$$y - e = 3e(x - 1) \Rightarrow y = 3ex - 2e$$

On checking all the options, the option $\left(\frac{4}{3}, 2e\right)$ satisfy the equation of tangent.

15. According to given information, we have the following figure

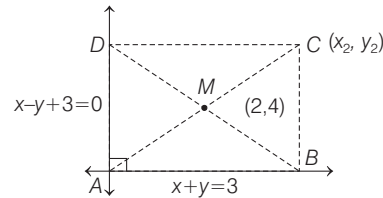

[Note that given lines are perpendicular to each other as $m_1 \times m_2 = -1$]

Clearly, point A is point of intersection of lines

$$x + y = 3 \quad \dots(i)$$

$$\text{and } x - y = -3 \quad \dots(ii)$$

So, $A = (0, 3)$ solving Eqs. (i) and (ii)

Now, as point $M(2, 4)$ is mid-point of line joining the points A and C , so

$$(2, 4) = \left(\frac{0 + x_2}{2}, \frac{3 + y_2}{2}\right)$$

$$\left[\because \text{mid-point} = \left(\frac{x_1 + x_2}{2}, \frac{y_1 + y_2}{2}\right) \right]$$

$$\Rightarrow 2 = \frac{0 + x_2}{2}; 4 = \frac{3 + y_2}{2}$$

$$\Rightarrow x_2 = 4 \text{ and } y_2 = 5$$

$$\therefore \text{Thus, } C \equiv (4, 5)$$

Now, equation of line BC is given by

$$(y - y_1) = m(x - x_1)$$

$$y - 5 = 1(x - 4)$$

[line BC is parallel to $x - y + 3 = 0$ and slope

$$\text{of } x - y + 3 = 0 \text{ is } \frac{(-1)}{(-1)} = 1]$$

$$\Rightarrow y = x + 1 \quad \dots(iii)$$

and equation of line DC is

$$y - 5 = -1(x - 4)$$

$$\left[\text{line } DC \text{ is parallel to } x + y = 3 \text{ and slope of } x + y = 3 \text{ is } \frac{-1}{1} = -1 \right]$$

$$\Rightarrow x + y = 9 \quad \dots(iv)$$

On solving Eqs. (i) and (iii), we get $B(1, 2)$ and on solving Eqs. (ii) and (iv), we get $D(3, 6)$

16. Let $P(x_1, y_1)$ be any point on the curve $y = \sqrt{x}$.

Clearly, $y_1 = \sqrt{x_1} \Rightarrow x_1 = y_1^2$ [$\because (x_1, y_1)$ lies on $y = \sqrt{x}$]

\therefore The point is $P(y_1^2, y_1)$

Now, let the given point be $A\left(\frac{3}{2}, 0\right)$, then

$$\begin{aligned} PA &= \sqrt{\left(y_1^2 - \frac{3}{2}\right)^2 + y_1^2} = \sqrt{y_1^4 - 3y_1^2 + \frac{9}{4} + y_1^2} \\ &= \sqrt{y_1^4 - 2y_1^2 + \frac{9}{4}} = \sqrt{(y_1^2 - 1)^2 + \frac{5}{4}} \end{aligned}$$

Clearly, PA will be least when

$$y_1^2 - 1 = 0$$

$$\Rightarrow PA_{\min} = \sqrt{0 + \frac{5}{4}} = \frac{\sqrt{5}}{2}$$

17. Given equation of line is

$$3x + 4y - 24 = 0$$

For intersection with X -axis put $y = 0$

$$\Rightarrow 3x - 24 = 0 \Rightarrow x = 8$$

For intersection with Y -axis, put $x = 0$

$$\Rightarrow 4y - 24 = 0 \Rightarrow y = 6$$

$\therefore A(8, 0)$ and $B(0, 6)$

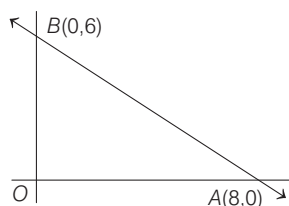

$$\text{Let } AB = c = \sqrt{8^2 + 6^2} = 10$$

$$OB = a = 6$$

and $OA = b = 8$

Also, let incentre is (h, k) , then

$$h = \frac{ax_1 + bx_2 + cx_3}{a + b + c} \quad (\text{here,}$$

$$x_1 = 8, x_2 = 0, x_3 = 0)$$

$$= \frac{6 \times 8 + 8 \times 0 + 10 \times 0}{6 + 8 + 10}$$

$$= \frac{48}{24} = 2$$

$$\text{and } k = \frac{ay_1 + by_2 + cy_3}{a + b + c} \quad (\text{here, } y_1 = 0, y_2 = 6, y_3 = 0)$$

$$= \frac{6 \times 0 + 8 \times 6 + 10 \times 0}{6 + 8 + 10} = \frac{48}{24} = 2$$

\therefore Incentre is $(2, 2)$.

18. Let the coordinates of point P be (x_1, y_1)

$\because P$ lies on the line $2x - 3y + 4 = 0$

$$\therefore 2x_1 - 3y_1 + 4 = 0$$

$$\Rightarrow y_1 = \frac{2x_1 + 4}{3} \quad \dots(i)$$

Now, let the centroid of ΔPQR be $G(h, k)$, then

$$h = \frac{x_1 + 1 + 3}{3}$$

$$\Rightarrow x_1 = 3h - 4 \quad \dots(ii)$$

$$\text{and } k = \frac{y_1 + 4 - 2}{3}$$

$$\Rightarrow k = \frac{\frac{2x_1 + 4}{3} + 2}{3} \quad [\text{from Eq. (i)}]$$

$$\Rightarrow 3k = \frac{2x_1 + 4 + 6}{3}$$

$$\Rightarrow 9k - 10 = 2x_1 \quad \dots(iii)$$

Now, from Eqs. (ii) and (iii), we get

$$2(3h - 4) = 9k - 10$$

$$\Rightarrow 6h - 8 = 9k - 10$$

$$\Rightarrow 6h - 9k + 2 = 0$$

Now, replace h by x and k by y .

$\Rightarrow 6x - 9y + 2 = 0$, which is the required locus and slope of this line is $\frac{2}{3}$ [\because slope of $ax + by + c = 0$ is $-\frac{a}{b}$]

- 19.

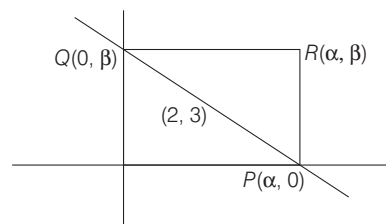

$$\text{Equation of line } PQ \text{ is } \frac{x}{\alpha} + \frac{y}{\beta} = 1$$

Since this line is passes through fixed point $(2, 3)$.

$$\therefore \frac{2}{\alpha} + \frac{3}{\beta} = 1$$

$$\therefore \text{Locus of } R \text{ is } 2\beta + 3\alpha = \alpha\beta$$

$$\text{i.e. } 2y + 3x = xy$$

$$\Rightarrow 3x + 2y = xy$$

20. Given, vertices of triangle are $(k, -3k)$, $(5, k)$ and $(-k, 2)$.

$$\therefore \frac{1}{2} \begin{vmatrix} k & -3k & 1 \\ 5 & k & 1 \\ -k & 2 & 1 \end{vmatrix} = \pm 28$$

$$\Rightarrow \begin{vmatrix} k & -3k & 1 \\ 5 & k & 1 \\ -k & 2 & 1 \end{vmatrix} = \pm 56$$

$$\Rightarrow k(k-2) + 3k(5+k) + 1(10+k^2) = \pm 56$$

$$\Rightarrow k^2 - 2k + 15k + 3k^2 + 10 + k^2 = \pm 56$$

$$\Rightarrow 5k^2 + 13k + 10 = \pm 56$$

$$\Rightarrow 5k^2 + 13k - 66 = 0$$

$$\text{or } 5k^2 + 13k - 46 = 0$$

$$\Rightarrow k = 2 \quad [\because k \in I]$$

Thus, the coordinates of vertices of triangle are $A(2, -6)$, $B(5, 2)$ and $C(-2, 2)$.

390 Straight Line and Pair of Straight Lines

Now, equation of altitude from vertex A is

$$y - (-6) = \frac{-1}{\left(\frac{2-2}{-2-5}\right)}(x-2) \Rightarrow x=2 \quad \dots(i)$$

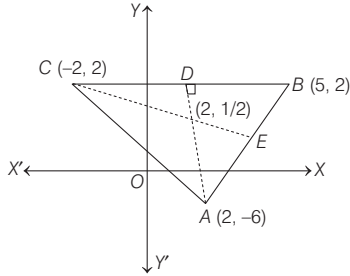

Equation of altitude from vertex C is

$$y-2 = \frac{-1}{\left[\frac{2-(-6)}{5-2}\right]}[x-(-2)]$$

$$\Rightarrow 3x + 8y - 10 = 0 \quad \dots(ii)$$

On solving Eqs. (i) and (ii), we get $x=2$ and $y=\frac{1}{2}$.

$$\therefore \text{Orthocentre} = \left(2, \frac{1}{2}\right)$$

- 21.** Let coordinate of the intersection point in fourth quadrant be $(\alpha, -\alpha)$.

Since, $(\alpha, -\alpha)$ lies on both lines $4ax + 2ay + c = 0$ and $5bx + 2by + d = 0$.

$$\therefore 4a\alpha - 2a\alpha + c = 0 \Rightarrow \alpha = \frac{-c}{2a} \quad \dots(i)$$

$$\text{and } 5b\alpha - 2b\alpha + d = 0 \Rightarrow \alpha = \frac{-d}{3b} \quad \dots(ii)$$

From Eqs. (i) and (ii), we get

$$\frac{-c}{2a} = \frac{-d}{3b} \Rightarrow 3bc = 2ad$$

$$\Rightarrow 2ad - 3bc = 0$$

- 22.** Coordinate of $S = \left(\frac{7+6}{2}, \frac{3-1}{2}\right) = \left(\frac{13}{2}, 1\right)$

[$\because S$ is mid-point of line QR]

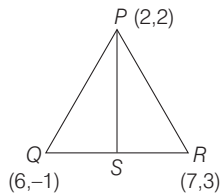

Slope of the line PS is $\frac{-2}{9}$.

Required equation passes through $(1, -1)$ and parallel to PS is

$$y + 1 = \frac{-2}{9}(x - 1)$$

$$\Rightarrow 2x + 9y + 7 = 0$$

- 23.** Given mid-points of a triangle are $(0, 1)$, $(1, 1)$ and $(1, 0)$. Plotting these points on a graph paper and make a triangle.

So, the sides of a triangle will be 2, 2 and $\sqrt{2^2 + 2^2}$ i.e. $2\sqrt{2}$.

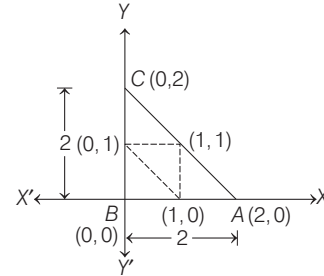

$$\begin{aligned} \text{x-coordinate of incentre} &= \frac{2 \times 0 + 2\sqrt{2} \cdot 0 + 2 \cdot 2}{2 + 2 + 2\sqrt{2}} \\ &= \frac{2}{2 + \sqrt{2}} \times \frac{2 - \sqrt{2}}{2 - \sqrt{2}} = 2 - \sqrt{2} \end{aligned}$$

- 24.** A straight line passing through P and making an angle of $\alpha = 60^\circ$, is given by

$$\frac{y - y_1}{x - x_1} = \tan(\theta \pm \alpha)$$

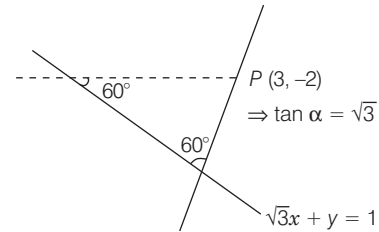

$$\Rightarrow \sqrt{3}x + y = 1$$

$$\Rightarrow y = -\sqrt{3}x + 1, \text{ then } \tan \theta = -\sqrt{3}$$

$$\Rightarrow \frac{y+2}{x-3} = \frac{\tan \theta \pm \tan \alpha}{1 \mp \tan \theta \tan \alpha}$$

$$\frac{y+2}{x-3} = \frac{-\sqrt{3} + \sqrt{3}}{1 - (-\sqrt{3})(\sqrt{3})}$$

$$\text{and } \frac{y+2}{x-3} = \frac{-\sqrt{3} - \sqrt{3}}{1 + (-\sqrt{3})(\sqrt{3})}$$

$$\Rightarrow y + 2 = 0$$

$$\text{and } \frac{y+2}{x-3} = \frac{-2\sqrt{3}}{1-3} = \sqrt{3}$$

$$y + 2 = \sqrt{3}x - 3\sqrt{3}$$

Neglecting, $y + 2 = 0$, as it does not intersect Y -axis.

- 25.** Given, lines are $(1+p)x - py + p(1+p) = 0 \quad \dots(i)$

$$\text{and } (1+q)x - qy + q(1+q) = 0 \quad \dots(ii)$$

On solving Eqs. (i) and (ii), we get

$$C\{pq, (1+p)(1+q)\}$$

\therefore Equation of altitude CM passing through C and perpendicular to AB is

$$x = pq \quad \dots(iii)$$

\therefore Slope of line (ii) is $\left(\frac{1+q}{q}\right)$.

\therefore Slope of altitude BN (as shown in figure) is $\frac{-q}{1+q}$.

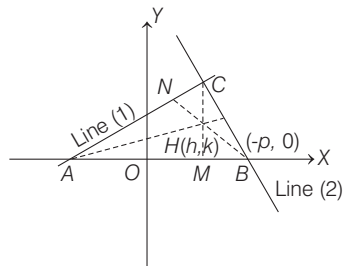

\therefore Equation of BN is $y-0 = \frac{-q}{1+q}(x+p)$

$$\Rightarrow y = \frac{-q}{(1+q)}(x+p) \quad \dots \text{(iv)}$$

Let orthocentre of triangle be $H(h, k)$, which is the point of intersection of Eqs. (iii) and (iv).

On solving Eqs. (iii) and (iv), we get

$$x = pq \text{ and } y = -pq$$

$$\Rightarrow h = pq \text{ and } k = -pq$$

$$\therefore h + k = 0$$

\therefore Locus of $H(h, k)$ is $x + y = 0$.

- 26.** Since, triangle is isosceles, hence centroid is the desired point.

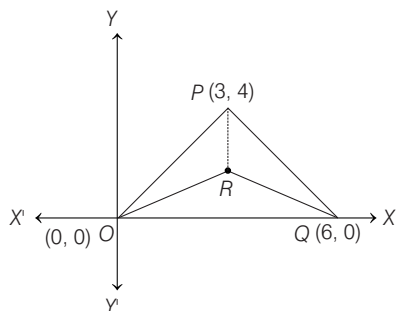

\therefore Coordinates of $R\left(3, \frac{4}{3}\right)$.

- 27.** To find orthocentre of the triangle formed by $(0, 0)$, $(3, 4)$ and $(4, 0)$.

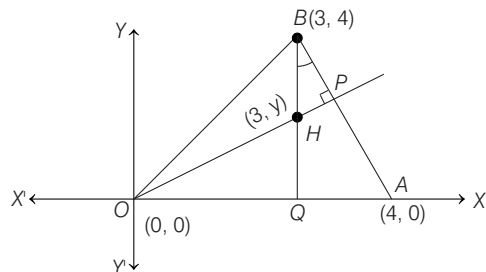

Let H be the orthocentre of ΔOAB

\therefore (slope of OP i.e. OH) \cdot (slope of BA) $= -1$

$$\Rightarrow \left(\frac{y-0}{3-0}\right) \cdot \left(\frac{4-0}{3-4}\right) = -1$$

$$\Rightarrow -\frac{4}{3}y = -1$$

$$\Rightarrow y = \frac{3}{4}$$

\therefore Required orthocentre $= (3, y) = \left(3, \frac{3}{4}\right)$

- 28.** On solving equations $3x + 4y = 9$ and $y = mx + 1$, we get

$$x = \frac{5}{3+4m}$$

Now, for x to be an integer,

$$3 + 4m = \pm 5 \text{ or } \pm 1$$

The integral values of m satisfying these conditions are -2 and -1 .

- 29.** Now, distance of origin from $4x + 2y - 9 = 0$ is

$$\frac{|-9|}{\sqrt{4^2 + 2^2}} = \frac{9}{\sqrt{20}}$$

and distance of origin from $2x + y + 6 = 0$ is

$$\frac{|6|}{\sqrt{2^2 + 1^2}} = \frac{6}{\sqrt{5}}$$

Hence, the required ratio $= \frac{9/\sqrt{20}}{6/\sqrt{5}} = \frac{3}{4}$

- 30.** Let the vertices of triangle be $A(1, \sqrt{3})$, $B(0, 0)$ and $C(2, 0)$. Here, $AB = BC = CA = 2$.

Therefore, it is an equilateral triangle. So, the incentre coincides with centroid.

$$\therefore I \equiv \left(\frac{0+1+2}{3}, \frac{0+0+\sqrt{3}}{3}\right)$$

$$\Rightarrow I \equiv (1, 1/\sqrt{3})$$

- 31.** Now, $(A_0A_1)^2 = \left(1 - \frac{1}{2}\right)^2 + \left(0 - \frac{\sqrt{3}}{2}\right)^2$

$$= \left(\frac{1}{2}\right)^2 + \left(\frac{\sqrt{3}}{2}\right)^2 = \frac{1}{4} + \frac{3}{4} = 1 \Rightarrow A_0A_1 = 1$$

$$(A_0A_2)^2 = \left(1 + \frac{1}{2}\right)^2 + \left(0 - \frac{\sqrt{3}}{2}\right)^2$$

$$= \left(\frac{3}{2}\right)^2 + \left(-\frac{\sqrt{3}}{2}\right)^2 = \frac{9}{4} + \frac{3}{4} = \frac{12}{4} = 3$$

$$\Rightarrow A_0A_2 = \sqrt{3}$$

$$\text{and } (A_0A_4)^2 = \left(1 + \frac{1}{2}\right)^2 + \left(0 + \frac{\sqrt{3}}{2}\right)^2$$

$$= \left(\frac{3}{2}\right)^2 + \left(\frac{3}{4}\right) = \frac{9}{4} + \frac{3}{4} = \frac{12}{4} = 3$$

$$\Rightarrow A_0A_4 = \sqrt{3}$$

$$\text{Thus, } (A_0A_1)(A_0A_2)(A_0A_4) = 3$$

- 32.** Since, the coordinates of the centroid are $\left(\frac{x_1 + x_2 + x_3}{3}, \frac{y_1 + y_2 + y_3}{3}\right)$, then the centroid is always a rational point.

392 Straight Line and Pair of Straight Lines

33. $PQRS$ is a parallelogram if and only if the mid point of the diagonals PR is same as that of the mid-point of QS . That is, if and only if

$$\frac{1+5}{2} = \frac{4+a}{2} \quad \text{and} \quad \frac{2+7}{2} = \frac{6+b}{2}$$

$$\Rightarrow \quad a=2 \quad \text{and} \quad b=3.$$

34. Slope of line $x+3y=4$ is $-1/3$
and slope of line $6x-2y=7$ is 3.

$$\text{Here,} \quad 3 \times \left(\frac{-1}{3}\right) = -1$$

Therefore, these two lines are perpendicular which show that both diagonals are perpendicular.

Hence, $PQRS$ must be a rhombus.

35. Let $y = \cos x \cos(x+2) - \cos^2(x+1)$
 $= \cos(x+1-1) \cos(x+1+1) - \cos^2(x+1)$
 $= \cos^2(x+1) - \sin^2 1 - \cos^2(x+1) \Rightarrow y = -\sin^2 1$

This is a straight line which is parallel to X -axis.

It passes through $(\pi/2, -\sin^2 1)$.

36. Orthocentre of right angled triangle is at the vertex of right angle. Therefore, orthocentre of the triangle is at $(0, 0)$.

37. By the given conditions, we can take two perpendicular lines as x and y axes. If (h, k) is any point on the locus, then $|h|+|k|=1$. Therefore, the locus is $|x|+|y|=1$. This consist of a square of side 1.

Hence, the required locus is a square.

38. Since, the origin remains the same. So, length of the perpendicular from the origin on the line in its position $\frac{x}{a} + \frac{y}{b} = 1$ and $\frac{x}{p} + \frac{y}{q} = 1$ are equal. Therefore,

$$\frac{1}{\sqrt{\frac{1}{a^2} + \frac{1}{b^2}}} = \frac{1}{\sqrt{\frac{1}{p^2} + \frac{1}{q^2}}} \Rightarrow \frac{1}{a^2} + \frac{1}{b^2} = \frac{1}{p^2} + \frac{1}{q^2}$$

39. Let the coordinate of S be (x, y) .

$$\begin{aligned} \because \quad & SQ^2 + SR^2 = 2SP^2 \\ \Rightarrow & (x+1)^2 + y^2 + (x-2)^2 + y^2 = 2[(x-1)^2 + y^2] \\ \Rightarrow & x^2 + 2x + 1 + y^2 + x^2 - 4x + 4 + y^2 = 2(x^2 - 2x + 1 + y^2) \\ \Rightarrow & 2x + 3 = 0 \Rightarrow x = -\frac{3}{2} \end{aligned}$$

Hence, it is a straight line parallel to Y -axis.

40. Let B, C, D be the position of the point $A(4, 1)$ after the three operations I, II and III, respectively. Then, B is $(1, 4)$, $C(1+2, 4)$ i.e. $(3, 4)$. The point D is obtained from C by rotating the coordinate axes through an angle $\pi/4$ in anti-clockwise direction.

Therefore, the coordinates of D are given by

$$X = 3 \cos \frac{\pi}{4} - 4 \sin \frac{\pi}{4} = -\frac{1}{\sqrt{2}}$$

$$\text{and} \quad Y = 3 \sin \frac{\pi}{4} + 4 \cos \frac{\pi}{4} = \frac{7}{\sqrt{2}}$$

$$\therefore \text{Coordinates of } D \text{ are } \left(-\frac{1}{\sqrt{2}}, \frac{7}{\sqrt{2}}\right).$$

41. The point $O(0,0)$ is the mid-point of $A(-a, -b)$ and $B(a, b)$. Therefore, A, O, B are collinear and equation of line AOB is

$$y = \frac{b}{a}x$$

Since, the fourth point $D(a^2, ab)$ satisfies the above equation.

Hence, the four points are collinear.

42. Here, $ax + 2y = \lambda$

$$\text{and} \quad 3x - 2y = \mu$$

For $a = -3$, above equations will be parallel or coincident, i.e. parallel for $\lambda + \mu \neq 0$ and coincident, if $\lambda + \mu = 0$ and if $a \neq -3$, equations are intersecting, i.e. unique solution.

43. **PLAN** Application of inequality sum and differences, along with lengths of perpendicular. For this type of questions involving inequality we should always check all options.

Situation analysis Check all the inequalities according to options and use length of perpendicular from the point (x_1, y_1) to $ax + by + c = 0$

$$\text{i.e.} \quad \frac{|ax_1 + by_1 + c|}{\sqrt{a^2 + b^2}}$$

$$\text{As} \quad a > b > c > 0$$

$$a - c > 0 \quad \text{and} \quad b > 0$$

$$\Rightarrow \quad a + b - c > 0 \quad \dots(i)$$

$$a - b > 0 \quad \text{and} \quad c > 0 \quad \dots(ii)$$

$$a + c - b > 0$$

\therefore Option (c) are correct.

Also, the point of intersection for $ax + by + c = 0$ and $bx + ay + c = 0$

$$\text{i.e.} \quad \left(\frac{-c}{a+b}, \frac{-c}{a+b}\right)$$

The distance between $(1, 1)$ and $\left(\frac{-c}{a+b}, \frac{-c}{a+b}\right)$

i.e. less than $2\sqrt{2}$.

$$\Rightarrow \quad \sqrt{\left(1 + \frac{c}{a+b}\right)^2 + \left(1 + \frac{c}{a+b}\right)^2} < 2\sqrt{2}$$

$$\Rightarrow \quad \left(\frac{a+b+c}{a+b}\right)\sqrt{2} < 2\sqrt{2}$$

$$\Rightarrow \quad a + b + c < 2a + 2b$$

$$\Rightarrow \quad a + b - c > 0$$

From Eqs. (i) and (ii), option (a) is correct.

44. Since, $3x + 2y \geq 0 \quad \dots(i)$

where $(1, 3)$ $(5, 0)$ and $(-1, 2)$ satisfy Eq. (i).

\therefore Option (a) is true.

$$\text{Again,} \quad 2x + y - 13 \geq 0$$

is not satisfied by $(1, 3)$,

\therefore Option (b) is false.

$$2x - 3y - 12 \leq 0$$

is satisfied for all points,

∴ Option (c) is true.

and $-2x + y \geq 0$

is not satisfied by (5, 0),

∴ Option (d) is false.

Thus, (a) and (c) are correct answers.

45. Let the variable straight line be $ax + by + c = 0$... (i)
 where, algebraic sum of perpendiculars from (2, 0), (0, 2) and (1, 1) is zero.

$$\therefore \frac{2a + 0 + c}{\sqrt{a^2 + b^2}} + \frac{0 + 2b + c}{\sqrt{a^2 + b^2}} + \frac{a + b + c}{\sqrt{a^2 + b^2}} = 0$$

$$\Rightarrow 3a + 3b + 3c = 0$$

$$\Rightarrow a + b + c = 0 \quad \dots \text{(ii)}$$

From Eqs. (i) and (ii) $ax + by + c = 0$ always passes through a fixed point (1, 1).

46. Let $H(h, k)$ be orthocentre.

$$\Rightarrow (\text{slope of } AH) \cdot (\text{slope of } BC) = -1$$

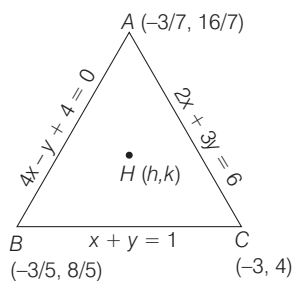

$$\Rightarrow \left(\frac{k - \frac{16}{7}}{h + \frac{3}{7}} \right) \cdot (-1) = -1$$

$$\Rightarrow k - \frac{16}{7} = h + \frac{3}{7}$$

$$\Rightarrow h - k = -\frac{19}{7} \quad \dots \text{(i)}$$

Also, (slope of CH) \cdot (slope of AB) = -1

$$\Rightarrow \frac{k - 4}{h + 3} \cdot (4) = -1$$

$$\Rightarrow 4k - 16 = -h - 3$$

$$\Rightarrow h + 4k = 13 \quad \dots \text{(ii)}$$

On solving Eqs. (i) and (ii), we get $h = \frac{3}{7}, k = \frac{22}{7}$

$$\therefore \text{Orthocentre } \left(\frac{3}{7}, \frac{22}{7} \right)$$

Hence, this coordinate lies in the first quadrant.

47. Since, a, b, c are in AP.

$$\therefore 2b = a + c$$

or $a - 2b + c = 0$ which satisfy $ax + by + c = 0$

∴ $ax + by + c = 0$ always pass through a fixed point (1, -2).

48. $y = 10^x$ is reflection of $y = \log_{10} x$ about $y = x$.

49. Since, $a_1x + b_1y + c_1 = 0$ and $a_2x + b_2y + c_2 = 0$ cuts the coordinate axes at concyclic points.

$$\Rightarrow a_1a_2 = b_1b_2$$

$$\text{or } a_1b_2 + b_1a_2 = 0$$

Given lines are, $2x + 3y + 19 = 0$

and $9x + 6y - 17 = 0$

Here, $a_1 = 2, b_1 = 3, c_1 = 19$

and $a_2 = 9, b_2 = 6, c_2 = -17$

∴ $a_1a_2 = 18$

and $b_1b_2 = 18$

∴ $a_1a_2 = b_1b_2$. Thus, points are concyclic.

Hence, given statement is true.

50. Since, $(1, \sqrt{3}), (1, -\sqrt{3})$ and $(3, \sqrt{3})$ form a right angled triangle at $(1, \sqrt{3})$

∴ Equation of circumcircle taking $(3, \sqrt{3})$ and $(1, -\sqrt{3})$ as end points of diameter.

$$\therefore (x - 3)(x - 1) + (y - \sqrt{3})(y + \sqrt{3}) = 0$$

$$\Rightarrow x^2 - 4x + 3 + y^2 - 3 = 0$$

$$\Rightarrow x^2 + y^2 - 4x = 0$$

$$\text{At point } \left(\frac{5}{2}, 1 \right), S_1 = \frac{25}{4} + 1 - 10 < 0$$

∴ Point $(5/2, 1)$ lies inside the circle.

Hence, no tangent can be drawn.

Hence, given statement is true.

51. The point of intersection of $x + 2y = 10$ and $2x + y + 5 = 0$ is $\left(-\frac{20}{3}, \frac{25}{3} \right)$ which clearly satisfy $5x + 4y = 0$.

Hence, given statement is true.

52. Let the equation of straight line L be

$$y = mx$$

$$P \equiv \left(\frac{1}{m+1}, \frac{m}{m+1} \right), Q \equiv \left(\frac{3}{m+1}, \frac{3m}{m+1} \right)$$

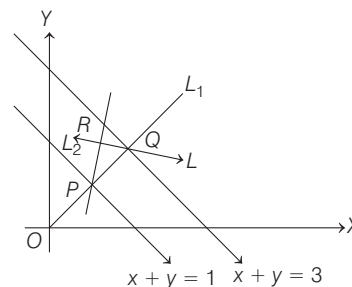

Now, equation of

$$L_1 : y - 2x = \frac{m-2}{m+1} \quad \dots \text{(i)}$$

and equation of

$$L_2 : y + 3x = \frac{3m+9}{m+1} \quad \dots \text{(ii)}$$

By eliminating m from Eqs. (i) and (ii), we get locus of R as $x - 3y + 5 = 0$, which represents a straight line.

394 Straight Line and Pair of Straight Lines

53. Let $L : (y - 2) = m(x - 8), m < 0$

The points P and Q are $(8 - \frac{2}{m}, 0)$ and $(0, 2 - 8m)$, respectively.

$$\text{Then, } OP + OQ = \left(8 - \frac{2}{m}\right) + (2 - 8m) = 10 + \left[-\frac{2}{m} + (-8m)\right]$$

[using AM \geq GM]

$$\Rightarrow \left(\frac{2}{-m}\right) + (-8m) \geq 2\sqrt{16} \quad [\because \frac{2}{m} \text{ and } -8m \text{ are positive}]$$

$$\Rightarrow -\left(\frac{2}{m} + 8m\right) \geq 8$$

$$\Rightarrow 10 - \left(\frac{2}{m} + 8m\right) \geq 10 + 8 \Rightarrow OP + OQ \geq 18$$

54. **NOTE** $d : (P, Q) = |x_1 - x_2| + |y_1 - y_2|$.

It is new method of representing distance between two points P and Q and in future very important in coordinate geometry.

Now, let $P(x, y)$ be any point in the first quadrant. We have

$$d(P, 0) = |x - 0| + |y - 0| = |x| + |y| = x + y \quad [\because x, y > 0]$$

$$d(P, A) = |X - 3| + |Y - 2| \quad [\text{given}]$$

$$d(P, 0) = d(P, A) \quad [\text{given}]$$

$$\Rightarrow x + y = |x - 3| + |y - 2| \quad \dots(i)$$

Case I When $0 < x < 3, 0 < y < 2$

In this case, Eq. (i) becomes

$$x + y = 3 - x + 2 - y$$

$$\Rightarrow 2x + 2y = 5$$

$$\text{or } x + y = 5/2$$

Case II When $0 < x < 3, y \geq 2$

Now, Eq. (i) becomes

$$x + y = 3 - x + y - 2$$

$$\Rightarrow 2x = 1$$

$$\Rightarrow x = 1/2$$

Case III When $x \geq 3, 0 < y < 2$

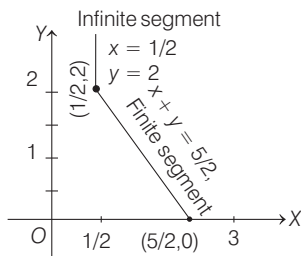

Now, Eq. (i) becomes

$$x + y = x - 3 + 2 - y$$

$$\Rightarrow 2y = -1 \text{ or } y = -1/2$$

Hence, no solution.

Case IV When $x \geq 3, y \geq 2$

In this case, case I changes to

$$x + y = x - 3 + y - 2 \Rightarrow 0 = -5$$

which is not possible.

Hence, the solution set is

$$\{(x, y) \mid x = 12, y \geq 2\} \cup \{(x, y) \mid x + y = 5/2, 0 < x < 3, 0 < y < 2\}$$

The graph is given in adjoining figure.

55. Let the coordinates of Q be (b, α) and that of S be $(-b, \beta)$. Suppose, PR and SQ meet in G . Since, G is mid point of SQ , its x -coordinate must be 0. Let the coordinates of R be (h, k) .

Since, G is mid point of PR , the x -coordinate of P must be $-h$ and as P lies on the line $y = a$, the coordinates of P are $(-h, a)$. Since, PQ is parallel to $y = mx$, slope of $PQ = m$

$$\Rightarrow \frac{\alpha - a}{b + h} = m \quad \dots(i)$$

Again, $RQ \perp PQ$

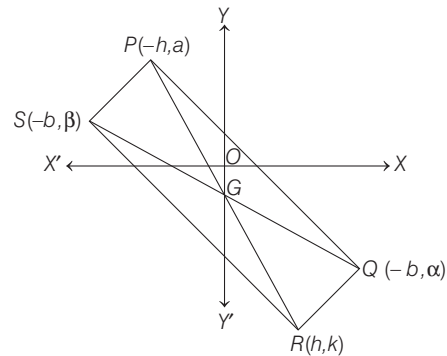

$$\text{Slope of } RQ = -\frac{1}{m} \Rightarrow \frac{k - \alpha}{h - b} = -\frac{1}{m} \quad \dots(ii)$$

From Eq. (i), we get

$$\alpha - a = m(b + h) \Rightarrow \alpha = a + m(b + h) \quad \dots(iii)$$

and from Eq. (ii), we get

$$k - \alpha = -\frac{1}{m}(h - b)$$

$$\Rightarrow \alpha = k + \frac{1}{m}(h - b) \quad \dots(iv)$$

From Eqs. (iii) and (iv), we get

$$a + m(b + h) = k + \frac{1}{m}(h - b)$$

$$\Rightarrow am + m^2(b + h) = km + (h - b)$$

$$\Rightarrow (m^2 - 1)h - mk + b(m^2 + 1) + am = 0$$

Hence, the locus of vertex is

$$(m^2 - 1)x - my + b(m^2 + 1) + am = 0$$

56. Let equation of line AC is

$$\frac{y + 4}{\sin \theta} = \frac{x + 5}{\cos \theta} = r$$

Let line AE make angle θ with X -axis and intersects $x + 3y + 2 = 0$ at B at a distance r_1 and line $2x + y + 4 = 0$ at C at a distance r_2 and line $x - y - 5 = 0$ at D at a distance r_3 .

$$\therefore AB = r_1, AC = r_2, AD = r_3.$$

$$r_1 = -\frac{-5 - 3 \times 4 + 2}{1 \cdot \cos \theta + 3 \cdot \sin \theta} \left[\because r = -\frac{I}{(\alpha \cos \theta + b \sin \theta)} \right]$$

$$\Rightarrow r_1 = \frac{15}{\cos \theta + 3 \sin \theta} \quad \dots(i)$$

Similarly,
$$r_2 = -\frac{2 \times (-5) + 1(-4) + 4}{2 \cos \theta + 1 \cdot \sin \theta}$$

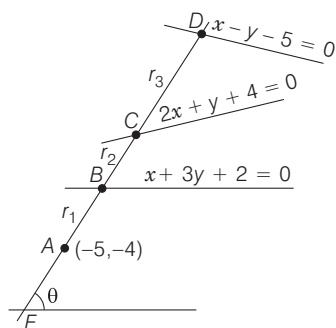

$$\Rightarrow r_2 = \frac{10}{2 \cos \theta + \sin \theta} \quad \dots(ii)$$

and
$$r_3 = -\frac{-5 \times 1 - 4(-1) - 5}{\cos \theta - \sin \theta}$$

$$\Rightarrow r_3 = \frac{6}{\cos \theta - \sin \theta} \quad \dots(iii)$$

But it is given that,

$$\left(\frac{15}{AB}\right)^2 + \left(\frac{10}{AC}\right)^2 = \left(\frac{6}{AD}\right)^2 \Rightarrow \left(\frac{15}{r_1}\right)^2 + \left(\frac{10}{r_2}\right)^2 = \left(\frac{6}{r_3}\right)^2$$

$$\Rightarrow (\cos \theta + 3 \sin \theta)^2 + (2 \cos \theta + \sin \theta)^2 = (\cos \theta - \sin \theta)^2$$

[from Eqs. (i), (ii) and (iii)]

$$\Rightarrow \cos^2 \theta + 9 \sin^2 \theta + 6 \cos \theta \sin \theta + 4 \cos^2 \theta + \sin^2 \theta + 4 \cos \theta \sin \theta = \cos^2 \theta + \sin^2 \theta - 2 \cos \theta \sin \theta$$

$$\Rightarrow 4 \cos^2 \theta + 9 \sin^2 \theta + 12 \sin \theta \cos \theta = 0$$

$$\Rightarrow (2 \cos \theta + 3 \sin \theta)^2 = 0$$

$$\Rightarrow 2 \cos \theta + 3 \sin \theta = 0$$

$$\Rightarrow \cos \theta = -\frac{3}{2} \sin \theta$$

On substituting this in equation of AC, we get

$$\frac{y+4}{\sin \theta} = \frac{x+5}{-\frac{3}{2} \sin \theta}$$

$$\Rightarrow -3(y+4) = 2(x+5)$$

$$\Rightarrow -3y - 12 = 2x + 10$$

$$\Rightarrow 2x + 3y + 22 = 0$$

which is the equation of required straight line.

57. Given lines are $2x + 3y - 1 = 0 \quad \dots(i)$

$$x + 2y - 3 = 0 \quad \dots(ii)$$

$$5x - 6y - 1 = 0 \quad \dots(iii)$$

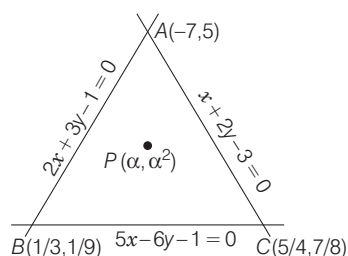

On solving Eqs. (i), (ii) and (iii), we get the vertices of a triangle are $A(-7, 5)$, $B\left(\frac{1}{3}, \frac{1}{9}\right)$ and $C\left(\frac{5}{4}, \frac{7}{8}\right)$.

Let $P(\alpha, \alpha^2)$ be a point inside the ΔABC . Since, A and P are on the same side of $5x - 6y - 1 = 0$, both $5(-7) - 6(5) - 1$ and $5\alpha - 6\alpha^2 - 1$ must have the same sign, therefore

$$\begin{aligned} &5\alpha - 6\alpha^2 - 1 < 0 \\ \Rightarrow &6\alpha^2 - 5\alpha + 1 > 0 \\ \Rightarrow &(3\alpha - 1)(2\alpha - 1) > 0 \\ \Rightarrow &\alpha < \frac{1}{3} \text{ or } \alpha > \frac{1}{2} \quad \dots(iv) \end{aligned}$$

Also, since $P(\alpha, \alpha^2)$ and $C\left(\frac{5}{4}, \frac{7}{8}\right)$ lie on the same side of $2x + 3y - 1 = 0$, therefore both $2\left(\frac{5}{4}\right) + 3\left(\frac{7}{8}\right) - 1$ and $2\alpha + 3\alpha^2 - 1$ must have the same sign.

Therefore, $2\alpha + 3\alpha^2 - 1 > 0$

$$\Rightarrow (\alpha + 1)\left(\alpha - \frac{1}{3}\right) > 0$$

$$\Rightarrow \alpha < -1 \cup \alpha > 1/3 \quad \dots(v)$$

and lastly $\left(\frac{1}{3}, \frac{1}{9}\right)$ and $P(\alpha, \alpha^2)$ lie on the same side of the line therefore, $\frac{1}{3} + 2\left(\frac{1}{9}\right) - 3$ and $\alpha + 2\alpha^2 - 3$ must have the same sign.

Therefore, $2\alpha^2 + \alpha - 3 < 0$

$$\Rightarrow 2\alpha(\alpha - 1) + 3(\alpha - 1) < 0$$

$$\Rightarrow (2\alpha + 3)(\alpha - 1) < 0 \Rightarrow -\frac{2}{3} < \alpha < 1$$

On solving Eqs. (i), (ii) and (iii), we get the common answer is $-\frac{2}{3} < \alpha < -1 \cup \frac{1}{2} < \alpha < 1$.

58. Let l makes an angle α with the given parallel lines and intercept AB is of 3 units.

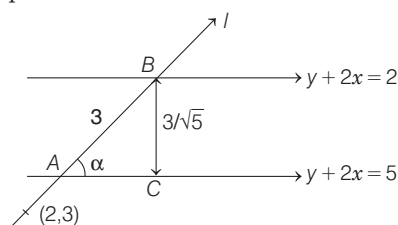

Now, distance between parallel lines

$$= \frac{|5 - 2|}{\sqrt{1^2 + 2^2}} = \frac{3}{\sqrt{5}}$$

$$\therefore \sin \alpha = \frac{1}{\sqrt{5}}, \cos \alpha = \frac{2}{\sqrt{5}}$$

, and $\tan \alpha = \frac{1}{2}$

\Rightarrow Equation of straight line passing through $(2, 3)$ and making an angle α with $y + 2x = 5$ is

$$\frac{y - 3}{x - 2} = \tan(\theta + \alpha)$$

396 Straight Line and Pair of Straight Lines

$$\Rightarrow \frac{y-3}{x-2} = \frac{\tan \theta + \tan \alpha}{1 - \tan \theta \tan \alpha}$$

and $\frac{y-3}{x-2} = \frac{\tan \theta - \tan \alpha}{1 + \tan \theta \tan \alpha}$

$$\Rightarrow \frac{y-3}{x-2} = -\frac{3}{4} \quad \text{and} \quad \frac{y-3}{x-2} = \frac{1}{0}$$

$$\Rightarrow 3x + 4y = 18 \quad \text{and} \quad x = 2$$

59. Let m_1 and m_2 be the slopes of the lines $3x + 4y = 5$ and $4x - 3y = 15$, respectively.

Then, $m_1 = -\frac{3}{4}$ and $m_2 = \frac{4}{3}$

Clearly, $m_1 m_2 = -1$. So, lines AB and AC are at right angle. Thus, the $\triangle ABC$ is a right angled isosceles triangle.

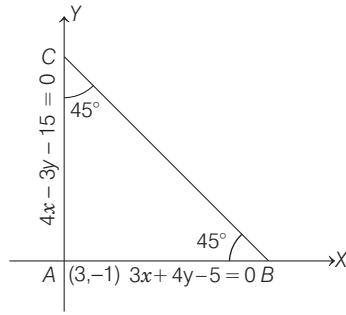

Hence, the line BC through $(1, 2)$ will make an angle of 45° with the given lines. So, the possible equations of BC are

$$(y - 2) = \frac{m \pm \tan 45^\circ}{1 \mp m \tan 45^\circ} (x - 1)$$

where, $m =$ slope of $AB = -\frac{3}{4}$

$$\Rightarrow (y - 2) = \frac{-\frac{3}{4} \pm 1}{1 \mp \left(-\frac{3}{4}\right)} (x - 1)$$

$$\Rightarrow (y - 2) = \frac{-3 \pm 4}{4 \pm 3} (x - 1)$$

$$\Rightarrow (y - 2) = \frac{1}{7} (x - 1)$$

and $(y - 2) = -7(x - 1)$

$$\Rightarrow x - 7y + 13 = 0$$

and $7x + y - 9 = 0$

60. The equation of the line AB is

$$\frac{x}{7} + \frac{y}{-5} = 1 \quad \dots (i)$$

$$\Rightarrow 5x - 7y = 35$$

Equation of line perpendicular to AB is

$$7x + 5y = \lambda \quad \dots (ii)$$

It meets X -axis at $P(\lambda/7, 0)$ and Y -axis at $Q(0, \lambda/5)$.

The equations of lines AQ and BP are $\frac{x}{7} + \frac{5y}{\lambda} = 1$ and

$$\frac{7x}{\lambda} - \frac{y}{5} = 1, \text{ respectively.}$$

Let $R(h, k)$ be their point of intersection of lines AQ and BP .

Then, $\frac{h}{7} + \frac{5k}{\lambda} = 1$

and $\frac{7h}{\lambda} - \frac{k}{5} = 1$

$$\Rightarrow \frac{1}{5k} \left(1 - \frac{h}{7}\right) = \frac{1}{7h} \left(1 + \frac{k}{5}\right) \quad [\text{on eliminating } \lambda]$$

$$\Rightarrow h(7 - h) = k(5 + k)$$

$$\Rightarrow h^2 + k^2 - 7h + 5k = 0$$

Hence, the locus of a point is

$$x^2 + y^2 - 7x + 5y = 0.$$

61. Let BC be taken as X -axis with origin at D , the mid-point of BC and DA will be Y -axis.

Given, $AB = AC$

Let $BC = 2a$, then the coordinates of B and C are $(-a, 0)$ and $(a, 0)$ let $A(0, h)$.

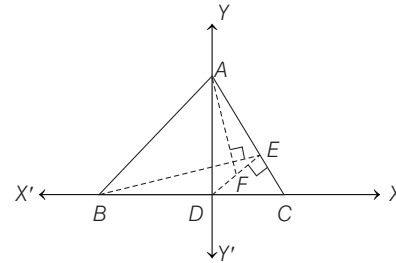

Then, equation of AC is

$$\frac{x}{a} + \frac{y}{h} = 1 \quad \dots (i)$$

and equation of $DE \perp AC$ and passing through origin is

$$\frac{x}{h} - \frac{y}{a} = 0$$

$$\Rightarrow x = \frac{hy}{a} \quad \dots (ii)$$

On solving, Eqs. (i) and (ii), we get the coordinates of point E as follows

$$\frac{hy}{a^2} + \frac{y}{h} = 1 \Rightarrow y = \frac{a^2 h}{a^2 + h^2}$$

$$\therefore \text{Coordinate of } E = \left(\frac{ah^2}{a^2 + h^2}, \frac{a^2 h}{a^2 + h^2} \right)$$

Since, F is mid-point of DE .

$$\therefore \text{Coordinate of } F = \left[\frac{ah^2}{2(a^2 + h^2)}, \frac{a^2 h}{2(a^2 + h^2)} \right]$$

\therefore Slope of AF ,

$$m_1 = \frac{h - \frac{a^2 h}{2(a^2 + h^2)}}{0 - \frac{ah^2}{2(a^2 + h^2)}} = \frac{2h(a^2 + h^2) - a^2 h}{-ah^2}$$

$$\Rightarrow m_1 = \frac{-(a^2 + 2h^2)}{ah} \quad \dots (iii)$$

$$\text{and slope of } BE, m_2 = \frac{\frac{a^2h}{a^2+h^2} - 0}{\frac{ah^2}{a^2+h^2} + a} = \frac{a^2h}{ah^2 + a^3 + ah^2}$$

$$\Rightarrow m_2 = \frac{ah}{a^2 + 2h^2} \quad \dots(\text{iv})$$

From Eqs. (iii) and (iv), $m_1 m_2 = -1 \Rightarrow AF \perp BE$

62. Let the coordinates of B and C be (x_1, y_1) and (x_2, y_2) respectively. Let m_1 and m_2 be the slopes of AB and AC , respectively. Then,

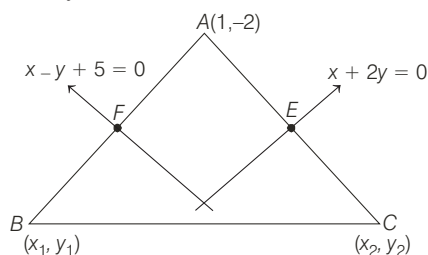

$$m_1 = \text{slope of } AB = \frac{y_1 + 2}{x_1 - 1}$$

and $m_2 = \text{slope of } AC = \frac{y_2 + 2}{x_2 - 1}$

Let F and E be the mid point of BC and AC , respectively.

Then, the coordinates of E and F are

$$E\left(\frac{x_2 + 1}{2}, \frac{y_2 - 2}{2}\right) \text{ and } F\left(\frac{x_1 + 1}{2}, \frac{y_1 - 2}{2}\right), \text{ respectively.}$$

Now, F lies on $x - y + 5 = 0$.

$$\Rightarrow \frac{x_1 + 1}{2} - \frac{y_1 - 2}{2} = -5$$

$$\Rightarrow x_1 - y_1 + 13 = 0 \quad \dots(\text{i})$$

Since, AB is perpendicular to $x - y + 5 = 0$.

$$\therefore (\text{slope of } AB) \cdot (\text{slope of } x - y + 5 = 0) = -1.$$

$$\Rightarrow \frac{y_1 + 2}{x_1 - 1} \cdot (1) = -1$$

$$\Rightarrow y_1 + 2 = -x_1 + 1$$

$$\Rightarrow x_1 + y_1 + 1 = 0 \quad \dots(\text{ii})$$

On solving Eqs. (i) and (ii), we get

$$x_1 = -7, y_1 = 6.$$

So, the coordinates of B are $(-7, 6)$.

Now, E lies on $x + 2y = 0$.

$$\therefore \frac{x_2 + 1}{2} + 2\left(\frac{y_2 - 2}{2}\right) = 0$$

$$\Rightarrow x_2 + 2y_2 - 3 = 0. \quad \dots(\text{iii})$$

Since, AC is perpendicular to $x + 2y = 0$

$$\therefore (\text{slope of } AC) \cdot (\text{slope of } x + 2y = 0) = -1$$

$$\Rightarrow \frac{y_2 + 2}{x_2 - 1} \cdot \left(-\frac{1}{2}\right) = -1$$

$$\Rightarrow 2x_2 - y_2 = 4 \quad \dots(\text{iv})$$

On solving Eqs. (iii) and (iv), we get

$$x_2 = \frac{11}{5} \text{ and } y_2 = \frac{2}{5}$$

So, the coordinates of C are $\left(\frac{11}{5}, \frac{2}{5}\right)$.

Thus, the equation of BC is

$$y - 6 = \frac{2/5 - 6}{11/5 + 7}(x + 7)$$

$$\Rightarrow -23(y - 6) = 14(x + 7)$$

$$\Rightarrow 14x + 23y - 40 = 0$$

63. Let O be the centre of circle and M be mid-point of AB .

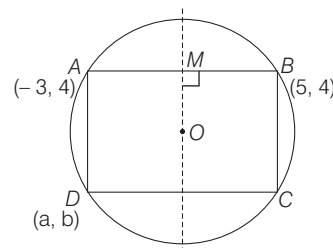

Then, $OM \perp AB \Rightarrow M(1, 4)$

Since, slope of $AB = 0$

Equation of straight line MO is $x = 1$ and equation of diameter is $4y = x + 7$.

\Rightarrow Centre is $(1, 2)$. Also, O is mid-point of BD

$$\Rightarrow \left(\frac{\alpha + 5}{2}, \frac{\beta + 4}{2}\right) = (1, 2)$$

$$\Rightarrow \alpha = -3, \beta = 0$$

$$\therefore AD = \sqrt{(-3 + 3)^2 + (4 - 0)^2} = 4$$

and $AB = \sqrt{64 + 0} = 8$

Thus, area of rectangle = $8 \times 4 = 32$ sq units

64. Let the coordinates of A be $(0, \alpha)$. Since, the sides AB and AD are parallel to the lines $y = x + 2$ and $y = 7x + 3$, respectively.

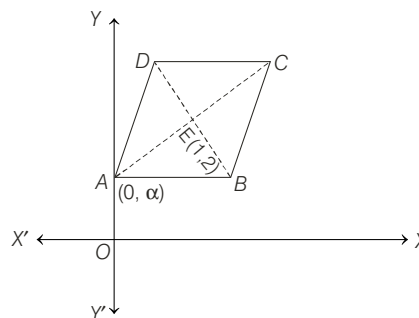

\therefore The diagonal AC is parallel to the bisector of the angle between these two lines. The equation of the bisectors are given by

$$\frac{x - y + 2}{\sqrt{2}} = \pm \frac{7x - y + 3}{\sqrt{50}}$$

$$\Rightarrow 5(x - y + 2) = \pm(7x - y + 3)$$

$$\Rightarrow 2x + 4y - 7 = 0 \text{ and } 12x - 6y + 13 = 0.$$

Thus, the diagonals of the rhombus are parallel to the lines $2x + 4y - 7 = 0$ and $12x - 6y + 13 = 0$.

$$\therefore \text{Slope of } AE = -\frac{2}{4} \text{ or } \frac{12}{6}$$

398 Straight Line and Pair of Straight Lines

$$\Rightarrow \frac{2-\alpha}{1-0} = -\frac{1}{2} \quad \text{or} \quad \frac{2-\alpha}{1-0} = 2$$

$$\Rightarrow \alpha = \frac{5}{2} \quad \text{or} \quad \alpha = 0.$$

Hence, the coordinates are $(0, 5/2)$ or $(0, 0)$.

- 65.** The equation of any line passing through $(1, -10)$ is $y + 10 = m(x - 1)$.

Since, it makes equal angles, say θ , with the given lines, therefore

$$\tan \theta = \frac{m-7}{1+7m} = \frac{m-(-1)}{1+m(-1)} \Rightarrow m = \frac{1}{3} \text{ or } -3$$

Hence, the equations of third side are

$$y + 10 = \frac{1}{3}(x - 1) \quad \text{or} \quad y + 10 = -3(x - 1)$$

i.e. $x - 3y - 31 = 0$ or $3x + y + 7 = 0$

- 66.** Let ABC be a triangle whose vertices are $A[at_1t_2, a(t_1 + t_2)]$, $B[at_2t_3, a(t_2 + t_3)]$ and $C[at_1t_3, a(t_1 + t_3)]$.

$$\text{Then, Slope of } BC = \frac{a(t_2 + t_3) - a(t_1 + t_3)}{at_2t_3 - at_1t_3} = \frac{1}{t_3}$$

$$\text{Slope of } AC = \frac{a(t_1 + t_3) - a(t_1 + t_2)}{at_1t_3 - at_1t_2} = \frac{1}{t_1}$$

So, the equation of a line through A perpendicular to BC is $y - a(t_1 + t_2) = -t_3(x - at_1t_2)$... (i)

and the equation of a line through B perpendicular to AC is

$$y - a(t_2 + t_3) = -t_1(x - at_2t_3) \quad \dots(ii)$$

The point of intersection of Eqs. (i) and (ii), is the orthocentre.

On subtracting Eq. (ii) from Eq. (i), we get $x = -a$.

On putting $x = -a$ in Eq. (i), we get

$$y = a(t_1 + t_2 + t_3 + t_1t_2t_3)$$

Hence, the coordinates of the orthocentre are $[-a, a(t_1 + t_2 + t_3 + t_1t_2t_3)]$.

- 67.** Let $OA = a$ and $OB = b$. Then, the coordinates of A and B are $(a, 0)$ and $(0, b)$ respectively and also, coordinates of P are (a, b) . Let θ be the foot of perpendicular from P on AB and let the coordinates of $Q(h, k)$. Here, a and b are the variable and we have to find locus of Q .

$$\text{Given, } AB = c \Rightarrow AB^2 = c^2$$

$$\Rightarrow OA^2 + OB^2 = c^2 \Rightarrow a^2 + b^2 = c^2 \quad \dots(i)$$

Since, PQ is perpendicular to AB .

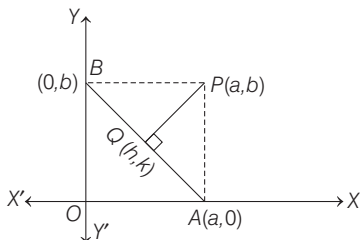

$$\Rightarrow \text{Slope of } AB \cdot \text{Slope of } PQ = -1$$

$$\Rightarrow \frac{0-b}{a-0} \cdot \frac{k-b}{h-a} = -1$$

$$\Rightarrow bk - b^2 = ah - a^2$$

$$\Rightarrow ah - bk = a^2 - b^2 \quad \dots(ii)$$

$$\text{Equation of line } AB \text{ is } \frac{x}{a} + \frac{y}{b} = 1.$$

Since, Q lies on AB , therefore

$$\frac{h}{a} + \frac{k}{b} = 1$$

$$\Rightarrow bh + ak = ab \quad \dots(iii)$$

On solving Eqs. (ii) and (iii), we get

$$\frac{h}{ab^2 + a(a^2 - b^2)} = \frac{k}{-b(a^2 - b^2) + a^2b} = \frac{1}{a^2 + b^2}$$

$$\Rightarrow \frac{h}{a^3} = \frac{k}{b^3} = \frac{1}{c^2} \quad [\text{from Eq. (i)}]$$

$$\Rightarrow a = (hc^2)^{1/3} \quad \text{and} \quad b = (kc^2)^{1/3}$$

On substituting the values of a and b in $a^2 + b^2 = c^2$, we get $h^{2/3} + k^{2/3} = c^{2/3}$

Hence, locus of a point is $x^{2/3} + y^{2/3} = c^{2/3}$.

- 68.** Since, diagonals of rectangle bisect each other, so mid point of $(1, 3)$ and $(5, 1)$ must satisfy $y = 2x + c$, i.e. $(3, 2)$ lies on it.

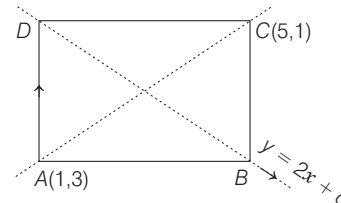

$$\Rightarrow 2 = 6 + c$$

$$\Rightarrow c = -4$$

\therefore Other two vertices lies on $y = 2x - 4$

Let the coordinate of B be $(x, 2x - 4)$.

\therefore Slope of $AB \cdot$ Slope of $BC = -1$

$$\Rightarrow \left(\frac{2x-4-3}{x-1}\right) \cdot \left(\frac{2x-4-1}{x-5}\right) = -1$$

$$\Rightarrow (x^2 - 6x + 8) = 0$$

$$\Rightarrow x = 4, 2 \Rightarrow y = 4, 0$$

Hence, required points are $(4, 4), (2, 0)$.

- 69.** Let the coordinates of third vertex be $C(a, b)$.

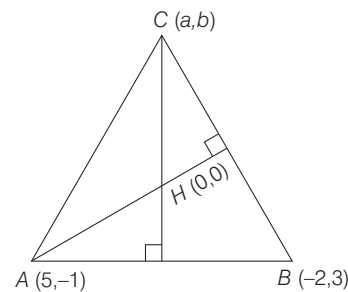

Since, CH is \perp AB ,

$$\therefore \left(\frac{b}{a}\right) \left(\frac{4}{-7}\right) = -1$$

$$\Rightarrow 4b = 7a \quad \dots(i)$$

Also, $AH \perp BC$

$$\therefore \left(-\frac{1}{5}\right)\left(\frac{3-b}{-2-a}\right) = -1$$

$$\Rightarrow 3 - b = -10 - 5a \quad \dots(\text{ii})$$

On solving Eqs. (i) and (ii), we get

$$a = -4, b = -7$$

70. Since, the side AB is perpendicular to AD .

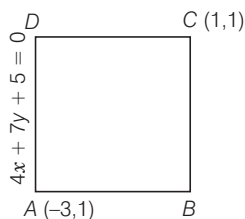

\therefore Its equation is of the form $7x - 4y + \lambda = 0$

Since, it passes through $(-3, 1)$.

$$\therefore 7(-3) - 4(1) + \lambda = 0.$$

$$\Rightarrow \lambda = 25$$

\therefore Equation of AB is

$$7x - 4y + 25 = 0$$

Now, BC is parallel to AD . Therefore, its equation is

$$4x + 7y + \lambda = 0$$

Since, it passes through $(1, 1)$.

$$\therefore 4(1) + 7(1) + \lambda = 0$$

$$\Rightarrow \lambda = -11$$

\therefore Equation of BC is $4x + 7y - 11 = 0$

Now, equation of DC is $7x - 4y + \lambda = 0$

$$\Rightarrow 7(1) - 4(1) + \lambda = 0$$

$$\Rightarrow \lambda = -3$$

$$\therefore 7x - 4y - 3 = 0$$

71. Given vertices of triangle ABC are $A(1, 0)$, $B(6, 2)$ and $C\left(\frac{3}{2}, 6\right)$ and the centroid of triangle G divides the triangle such that area of triangles AGB , BGC and CGA are equal, so point P is the centroid of triangle G .

$$\therefore \text{Coordinate of } P\left(\frac{1+6+\frac{3}{2}}{3}, \frac{0+2+6}{3}\right)$$

$$= P\left(\frac{17}{6}, \frac{8}{3}\right)$$

and given point $Q\left(-\frac{7}{6}, -\frac{1}{3}\right)$.

So length of the line segment PQ

$$= \sqrt{\left(\frac{17}{6} + \frac{7}{6}\right)^2 + \left(\frac{8}{3} + \frac{1}{3}\right)^2}$$

$$= \sqrt{\left(\frac{24}{6}\right)^2 + \left(\frac{9}{3}\right)^2}$$

$$= \sqrt{4^2 + 3^2} = \sqrt{16+9} = \sqrt{25} = 5$$

72. PLAN Distance of a point (x_1, y_1) from $ax + by + c = 0$ is given by

$$\left| \frac{ax_1 + by_1 + c}{\sqrt{a^2 + b^2}} \right|.$$

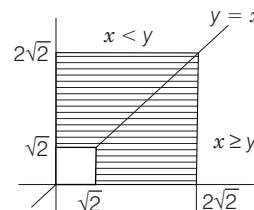

Let $P(x, y)$ is the point in first quadrant.

$$\text{Now, } 2 \leq \left| \frac{x-y}{\sqrt{2}} \right| + \left| \frac{x+y}{\sqrt{2}} \right| \leq 4$$

$$2\sqrt{2} \leq |x-y| + |x+y| \leq 4\sqrt{2}$$

Case I $x \geq y$

$$2\sqrt{2} \leq (x-y) + (x+y) \leq 4\sqrt{2}$$

$$\Rightarrow x \in [\sqrt{2}, 2\sqrt{2}]$$

Case II $x < y$

$$2\sqrt{2} \leq y-x + (x+y) \leq 4\sqrt{2}$$

$$y \in [\sqrt{2}, 2\sqrt{2}]$$

$$\Rightarrow A = (2\sqrt{2})^2 - (\sqrt{2})^2 = 6 \text{ sq units}$$

Topic 2 Angle between Straight Lines and Equation of Angle Bisector

1. According to the given situation, if we draw the diagram.

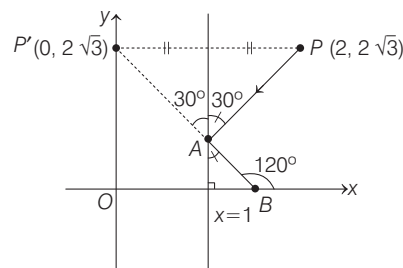

\therefore The line $x = 1$ is equidistance, from point $P(2, 2\sqrt{3})$ and the Y -axis.

So, $P'(0, 2\sqrt{3})$ and according to the concept of reflection line AB passes through $P'(0, 2\sqrt{3})$.

As the angle $\angle P'BX = \angle ABX = 120^\circ$

$$\therefore \text{Slope of line } AB = \tan 120^\circ = -\sqrt{3}$$

\therefore Equation of line AB is

$$y - 2\sqrt{3} = -\sqrt{3}(x - 0)$$

$$\Rightarrow \sqrt{3}x + y = 2\sqrt{3} \quad \dots(\text{i})$$

From the options, the line (i) passes through the point $(3, -\sqrt{3})$.

400 Straight Line and Pair of Straight Lines

2. Take any point $B(0, 1)$ on given line.

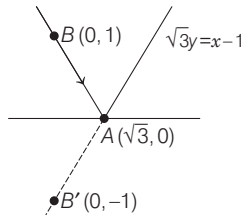

Equation of AB' is

$$y - 0 = \frac{-1 - 0}{0 - \sqrt{3}}(x - \sqrt{3})$$

$$\Rightarrow -\sqrt{3}y = -x + \sqrt{3}$$

$$\Rightarrow x - \sqrt{3}y = \sqrt{3}$$

$$\Rightarrow \sqrt{3}y = x - \sqrt{3}$$

3. For collinear points

$$\Delta = \begin{vmatrix} -\sin(\beta - \alpha) & -\cos\beta & 1 \\ \cos(\beta - \alpha) & \sin\beta & 1 \\ \cos(\beta - \alpha + \theta) & \sin(\beta - \theta) & 1 \end{vmatrix}$$

Clearly, $\Delta \neq 0$ for any value of α, β, θ .

Hence, points are non-collinear.

4. The line segment QR makes an angle of 60° with the positive direction of X -axis.

So, the bisector of the angle PQR will make an angle of 60° with the negative direction of X -axis it will therefore have angle of inclination of 120° and so, its equation is

$$y - 0 = \tan 120^\circ(x - 0)$$

$$\Rightarrow y = -\sqrt{3}x$$

$$\Rightarrow y + \sqrt{3}x = 0$$

5. It is not necessary that the bisector of an angle will divide the triangle into two similar triangles, therefore, statement II is false.

Now, we verify Statement I.

ΔOPQ , OR is the internal bisector of $\angle POQ$.

$$\therefore \frac{PR}{RQ} = \frac{OP}{OQ}$$

$$\Rightarrow \frac{PR}{RQ} = \frac{\sqrt{2^2 + 2^2}}{\sqrt{1^2 + 2^2}} = \frac{2\sqrt{2}}{\sqrt{5}}$$

6. Equation of the line AB is $y - 1 = \frac{1 - (-7)}{5 - (-1)}(x - 5)$

$$\Rightarrow y - 1 = \frac{8}{6}(x - 5)$$

$$\Rightarrow y - 1 = \frac{4}{3}(x - 5)$$

$$\Rightarrow 3y - 3 = 4x - 20$$

$$\Rightarrow 3y - 4x + 17 = 0$$

Equation of the line BC is

$$y - 4 = \frac{4 - 1}{1 - 5}(x - 1)$$

$$\Rightarrow y - 4 = -\frac{3}{4}(x - 1)$$

$$\Rightarrow 4y - 16 = -3x + 3$$

$$\Rightarrow 3x + 4y - 19 = 0$$

Again, equation of the bisectors of the angles between two given lines AB and BC are

$$\frac{3y - 4x + 17}{\sqrt{3^2 + 4^2}} = \pm \frac{4y + 3x - 19}{\sqrt{4^2 + 3^2}}$$

$$\Rightarrow 3y - 4x + 17 = \pm(4y + 3x - 19)$$

$$\Rightarrow 3y - 4x + 17 = 4y + 3x - 19$$

and $3y - 4x + 17 = -(4y + 3x - 19)$

$$\Rightarrow 36 = y + 7x \quad \text{and} \quad 7y - x = 2$$

Out of these two, equation of the bisector of angle ABC is

$$7y = x + 2.$$

7. Here, the triangle formed by a line parallel to X -axis passing through $P(h, k)$ and the straight line $y = x$ and $y = 2 - x$ could be as shown below:

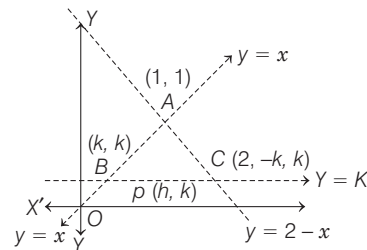

Since, area of $\Delta ABC = 4h^2$

$$\therefore \frac{1}{2} AB \cdot AC = 4h^2$$

where, $AB = \sqrt{2}|k - 1|$ and $AC = \sqrt{2}(|k - 1|)$

$$\Rightarrow \frac{1}{2} \cdot 2(k - 1)^2 = 4h^2$$

$$\Rightarrow 4h^2 = (k - 1)^2$$

$$\Rightarrow 2h = \pm(k - 1)$$

The locus of a point is $2x = \pm(y - 1)$.

8. Given equations of lines are

$$x - 2y + 4 = 0 \quad \text{and} \quad 4x - 3y + 2 = 0$$

Here, $a_1a_2 + b_1b_2 = 1(4) + (-2)(-3) = 10 > 0$

For obtuse angle bisector, we take negative sign.

$$\therefore \frac{x - 2y + 4}{\sqrt{5}} = -\frac{4x - 3y + 2}{5}$$

$$\Rightarrow \sqrt{5}(x - 2y + 4) = -(4x - 3y + 2)$$

$$\Rightarrow (4 + \sqrt{5})x - (2\sqrt{5} + 3)y + (4\sqrt{5} + 2) = 0$$

9. Since, the required line L passes through the intersection of $L_1 = 0$ and $L_2 = 0$.

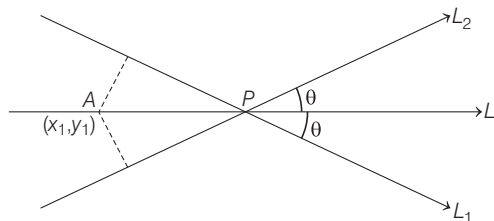

So, the equation of the required line L is

$$L_1 + \lambda L_2 = 0.$$

$$\text{i.e. } (ax + by + c) + \lambda (lx + my + n) = 0 \quad \dots(i)$$

where, λ is a parameter.

Since, L_1 is the angle bisector of $L = 0$ and $L_2 = 0$.

\therefore Any point $A(x_1, y_1)$ on L_1 is equidistant from $L_1 = 0$ and $L_2 = 0$.

$$\Rightarrow \frac{|lx_1 + my_1 + n|}{\sqrt{l^2 + m^2}} = \frac{|(ax_1 + by_1 + c) + \lambda (lx_1 + my_1 + n)|}{\sqrt{(a + \lambda l)^2 + (b + \lambda m)^2}} \quad \dots(ii)$$

But, $A(x_1, y_1)$ lies on L_1 . So, it must satisfy the equation of L_1 , i.e. $ax_1 + by_1 + c = 0$.

On substituting $ax_1 + by_1 + c = 0$ in Eq. (ii), we get

$$\frac{|lx_1 + my_1 + n|}{\sqrt{l^2 + m^2}} = \frac{|0 + \lambda (lx_1 + my_1 + n)|}{\sqrt{(a + \lambda l)^2 + (b + \lambda m)^2}}$$

$$\Rightarrow \lambda^2(l^2 + m^2) = (a + \lambda l)^2 + (b + \lambda m)^2$$

$$\therefore \lambda = -\frac{(a^2 + b^2)}{2(al + bm)}$$

On substituting the value of λ in Eq. (i), we get

$$(ax + by + c) - \frac{(a^2 + b^2)}{2(al + bm)}(lx + my + n) = 0$$

$$\Rightarrow 2(al + bm)(ax + by + c) - (a^2 + b^2)(lx + my + n) = 0$$

which is the required equation of line L .

Topic 3 Area and Family of Concurrent Lines

1. Let a ΔABC is such that vertices

$A(1, 2)$, $B(x_1, y_1)$ and $C(x_2, y_2)$.

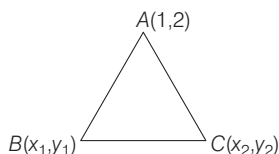

It is given that mid-point of side AB is $(-1, 1)$.

$$\text{So, } \frac{x_1 + 1}{2} = -1$$

$$\text{and } \frac{y_1 + 2}{2} = 1$$

$$\Rightarrow x_1 = -3 \text{ and } y_1 = 0$$

So, point B is $(-3, 0)$

Also, it is given that mid-point of side AC is $(2, 3)$, so

$$\frac{x_2 + 1}{2} = 2 \text{ and } \frac{y_2 + 2}{2} = 3$$

$$\Rightarrow x_2 = 3 \text{ and } y_2 = 4$$

So, point C is $(3, 4)$.

Now, centroid of ΔABC is

$$G\left(\frac{1 + (-3) + 3}{3}, \frac{2 + 0 + 4}{3}\right) = G\left(\frac{1}{3}, 2\right)$$

2. Given, $px + qy + r = 0$ is the equation of line such that

$$3p + 2q + 4r = 0$$

Consider, $3p + 2q + 4r = 0$

$$\Rightarrow \frac{3p}{4} + \frac{2q}{4} + r = 0$$

(dividing the equation by 4)

$$\Rightarrow p\left(\frac{3}{4}\right) + q\left(\frac{1}{2}\right) + r = 0$$

$$\Rightarrow \left(\frac{3}{4}, \frac{1}{2}\right) \text{ satisfy } px + qy + r = 0$$

So, the lines always passes through the point $\left(\frac{3}{4}, \frac{1}{2}\right)$.

3. As the given lines $x - y + 1 = 0$ and $7x - y - 5 = 0$ are not parallel, therefore they represent the adjacent sides of the rhombus.

On solving $x - y + 1 = 0$ and $7x - y - 5 = 0$, we get $x = 1$ and $y = 2$. Thus, one of the vertex is $A(1, 2)$.

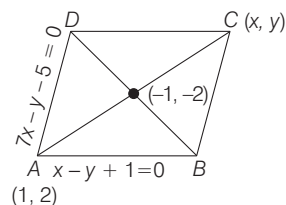

Let the coordinate of point C be (x, y) .

$$\text{Then, } -1 = \frac{x + 1}{2} \text{ and } -2 = \frac{y + 2}{2}$$

$$\Rightarrow x + 1 = -2 \text{ and } y = -4 - 2$$

$$\Rightarrow x = -3$$

$$\text{and } y = -6$$

Hence, coordinates of $C = (-3, -6)$

Note that, vertices B and D will satisfy $x - y + 1 = 0$ and $7x - y - 5 = 0$, respectively.

Since, option (c) satisfies $7x - y - 5 = 0$, therefore coordinate of vertex D is $\left(\frac{1}{3}, \frac{-8}{3}\right)$.

4. Let lines $OB: y = mx$

$$CA: y = mx + 1$$

$$BA: y = nx + 1$$

$$\text{and } OC: y = nx$$

402 Straight Line and Pair of Straight Lines

The point of intersection B of OB and AB has x coordinate $\frac{1}{m-n}$.

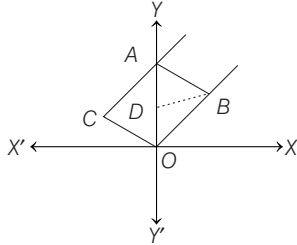

$$\begin{aligned} \text{Now, area of a parallelogram } OBAC &= 2 \times \text{area of } \triangle OBA \\ &= 2 \times \frac{1}{2} \times OA \times DB = 2 \times \frac{1}{2} \times \frac{1}{m-n} \\ &= \frac{1}{m-n} = \frac{1}{|m-n|} \end{aligned}$$

depending upon whether $m > n$ or $m < n$.

5. Since, vertices of a triangle are $(0, 8/3), (1, 3)$ and $(82, 30)$

$$\begin{aligned} \text{Now, } \frac{1}{2} \begin{vmatrix} 0 & 8/3 & 1 \\ 1 & 3 & 1 \\ 82 & 30 & 1 \end{vmatrix} &= \frac{1}{2} \left[-\frac{8}{3}(1-82) + 1(30-246) \right] \\ &= \frac{1}{2} [216 - 216] = 0 \end{aligned}$$

\therefore Points are collinear.

6. The points of intersection of three lines are $A(1, 1), B(2, -2), C(-2, 2)$.

$$\begin{aligned} \text{Now, } |AB| &= \sqrt{1+9} = \sqrt{10}, \\ |BC| &= \sqrt{16+16} = 4\sqrt{2}, \\ \text{and } |CA| &= \sqrt{9+1} = \sqrt{10} \end{aligned}$$

\therefore Triangle is an isosceles.

7. Given lines, $x+2y-3=0$ and $3x+4y-7=0$ intersect at $(1, 1)$, which does not satisfy $2x+3y-4=0$ and $4x+5y-6=0$.

Also, $3x+4y-7=0$ and $2x+3y-4=0$ intersect at $(5, -2)$ which does not satisfy $x+2y-3=0$ and $4x+5y-6=0$.

Lastly, intersection point of $x+2y-3=0$ and $2x+3y-4=0$ is $(-1, 2)$ which satisfy $4x+5y-6=0$. Hence, only three lines are concurrent.

8. Given lines $px+qy+r=0, qx+ry+p=0$

and $rx+py+q=0$ are concurrent.

$$\therefore \begin{vmatrix} p & q & r \\ q & r & p \\ r & p & q \end{vmatrix} = 0$$

Applying $R_1 \rightarrow R_1 + R_2 + R_3$ and taking common from R_1

$$(p+q+r) \begin{vmatrix} 1 & 1 & 1 \\ q & r & p \\ r & p & q \end{vmatrix} = 0$$

$$\begin{aligned} \Rightarrow (p+q+r)(p^2+q^2+r^2-pq-qr-pr) &= 0 \\ \Rightarrow p^3+q^3+r^3-3pqr &= 0 \end{aligned}$$

Therefore, (a) and (c) are the answers.

9. (A) Solving equations L_1 and L_3 ,

$$\frac{x}{-36+10} = \frac{y}{-25+12} = \frac{1}{2-15}$$

$$\therefore x=2, y=1$$

L_1, L_2, L_3 are concurrent, if point $(2, 1)$ lies on L_2

$$\therefore 6-k-1=0 \Rightarrow k=5$$

- (B) Either L_1 is parallel to L_2 , or L_3 is parallel to L_2 , then

$$\frac{1}{3} = \frac{3}{-k} \text{ or } \frac{3}{5} = \frac{-k}{2}$$

$$\Rightarrow k=-9$$

$$\text{or } k = \frac{-6}{5}$$

- (C) L_1, L_2, L_3 form a triangle, if they are not concurrent, or not parallel.

$$\therefore k \neq 5, -9, -\frac{6}{5}$$

$$\Rightarrow k = \frac{5}{6}$$

- (D) L_1, L_2, L_3 do not form a triangle, if

$$k=5, -9, -\frac{6}{5}$$

10. The set of lines $ax+by+c=0$, where $3a+2b+4c=0$ or $\frac{3}{4}a+\frac{1}{2}b+c=0$ are concurrent at $\left(x=\frac{3}{4}, y=\frac{1}{2}\right)$ i.e.

comparing the coefficients of x and y .

Thus, point of concurrency is $\left(\frac{3}{4}, \frac{1}{2}\right)$.

Alternate Solution

As, $ax+by+c=0$, satisfy $3a+2b+4c=0$ which represents system of concurrent lines whose point of concurrency could be obtained by comparison as,

$$ax+by+c \equiv \frac{3a}{4} + \frac{2}{4}b + c$$

$$\Rightarrow x = \frac{3}{4}, y = \frac{1}{2} \text{ is point of concurrency.}$$

$\therefore \left(\frac{3}{4}, \frac{1}{2}\right)$ is the required point.

11. Since, $\begin{vmatrix} x_1 & y_1 & 1 \\ x_2 & y_2 & 1 \\ x_3 & y_3 & 1 \end{vmatrix} = \begin{vmatrix} a_1 & b_1 & 1 \\ a_2 & b_2 & 1 \\ a_3 & b_3 & 1 \end{vmatrix}$

represents area of triangles are equal, which does not implies triangles are congruent. Hence, given statement is false.

12. Let the vertices of a triangle be, $O(0, 0)$ $A(a, 0)$ and $B(b, c)$ equation of altitude BD is $x=b$.

Slope of OB is $\frac{c}{b}$.

Slope of AF is $-\frac{b}{c}$.

Now, the equation of altitude AF is

$$y - 0 = -\frac{b}{c}(x - a)$$

Suppose, BD and OE intersect at P .

Coordinates of P are $\left[b, b\left(\frac{a-b}{c}\right) \right]$

Let m_1 be the slope of $OP = \frac{a-b}{c}$

and m_2 be the slope of $AB = \frac{c}{b-a}$

$$\text{Now, } m_1 m_2 = \left(\frac{a-b}{c}\right)\left(\frac{c}{b-a}\right) = -1$$

We get, that the line through O and P is perpendicular to AB .

$$\begin{aligned} 13. \frac{\text{Area of } \triangle PBC}{\text{Area of } \triangle ABC} &= \frac{\frac{1}{2}|x(5+2) + (-3)(-2-y) + 4(y-5)|}{\frac{1}{2}|6(5+2) + (-3)(-2-3) + 4(3-5)|} \\ &= \frac{|7x + 7y - 14|}{|42 + 15 - 8|} = \frac{7|x + y - 2|}{49} \\ &= \left| \frac{x + y - 2}{7} \right| \end{aligned}$$

14. A straight line perpendicular to $5x - y = 1$ is $x + 5y = \lambda$.

Since, area of triangle = 5

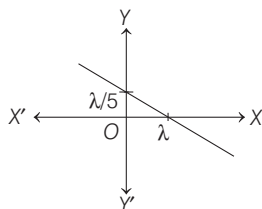

$$\Rightarrow \frac{1}{2} \left| \lambda \cdot \frac{\lambda}{5} \right| = 5$$

$$\Rightarrow \lambda^2 = 50$$

$$\Rightarrow |\lambda| = 5\sqrt{2}$$

\therefore Equation of the line L is, $x + 5y = \pm 5\sqrt{2}$

Topic 4 Homogeneous Equation of Pair of Straight Lines

1. Let a and b be non-zero real numbers.

Therefore the given equation

$(ax^2 + by^2 + c)(x^2 - 5xy + 6y^2) = 0$ implies either

$$x^2 - 5xy + 6y^2 = 0$$

$$\Rightarrow (x - 2y)(x - 3y) = 0$$

$$\Rightarrow x = 2y$$

$$\text{and } x = 3y$$

represent two straight lines passing through origin or $ax^2 + by^2 + c = 0$ when $c = 0$ and a and b are of same signs, then

$$ax^2 + by^2 + c = 0,$$

$$x = 0$$

$$\text{and } y = 0.$$

which is a point specified as the origin.

When, $a = b$ and c is of sign opposite to that of a , $ax^2 + by^2 + c = 0$ represents a circle.

Hence, the given equation,

$$(ax^2 + by^2 + c)(x^2 - 5xy + 6y^2) = 0$$

may represent two straight lines and a circle.

2. Given, $x^2 - y^2 + 2y = 1$

$$\Rightarrow x^2 = (y - 1)^2$$

$$\Rightarrow x = y - 1$$

$$\text{and } x = -y + 1$$

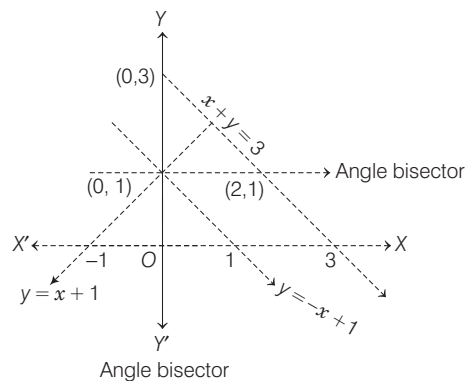

From the graph, it is clear that equation of angle bisectors are

$$y = 1$$

$$\text{and } x = 0$$

\therefore Area of region bounded by $x + y = 3$, $x = 0$

and $y = 1$ is $\Delta = \frac{1}{2} \times 2 \times 2 = 2$ sq units

3. The given curve is

$$3x^2 - y^2 - 2x + 4y = 0 \quad \dots(i)$$

Let $y = mx + c$ be the chord of curve (i) which subtend right angle at origin. Then, the combined equation of lines joining points of intersection of curve (i) and chord $y = mx + c$ to the origin, can be obtained by the equation of the curve homogeneous, i.e.

$$3x^2 - y^2 - 2x\left(\frac{y - mx}{c}\right) + 4y\left(\frac{y - mx}{c}\right) = 0$$

$$\Rightarrow 3cx^2 - cy^2 - 2xy + 2mx^2 + 4y^2 - 4mxy = 0$$

$$\Rightarrow (3c + 2m)x^2 - 2(1 + 2m)y + (4 - c)y^2 = 0$$

Since, the lines represented are perpendicular to each other.

$$\therefore \text{Coefficient of } x^2 + \text{Coefficient of } y^2 = 0$$

$$\Rightarrow 3c + 2m + 4 - c = 0$$

$$\Rightarrow c + m + 2 = 0$$

On comparing with $y = mx + c$

$$\Rightarrow y = mx + c \text{ passes through } (1, -2).$$

404 Straight Line and Pair of Straight Lines

Topic 5 General Equation of Pair of Straight Lines

1. Let S be the mid-point of QR and given ΔPQR is an isosceles.

Therefore, $PS \perp QR$ and S is mid-point of hypotenuse, therefore S is equidistant from P, Q, R .

$$\therefore PS = QS = RS$$

Since, $\angle P = 90^\circ$ and $\angle Q = \angle R$

$$\text{But } \angle P + \angle Q + \angle R = 180^\circ$$

$$\therefore 90^\circ + \angle Q + \angle R = 180^\circ$$

$$\Rightarrow \angle Q = \angle R = 45^\circ$$

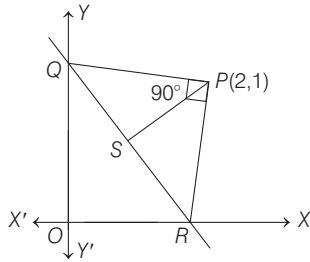

Now, slope of QR is -2 .

[given]

But $QR \perp PS$.

\therefore Slope of PS is $1/2$.

Let m be the slope of PQ .

$$\therefore \tan(\pm 45^\circ) = \frac{m - 1/2}{1 - m(-1/2)}$$

$$\Rightarrow \pm 1 = \frac{2m - 1}{2 + m}$$

$$\Rightarrow m = 3, -1/3$$

\therefore Equations of PQ and PR are

$$y - 1 = 3(x - 2)$$

and $y - 1 = -\frac{1}{3}(x - 2)$

or $3(y - 1) + (x - 2) = 0$

Therefore, joint equation of PQ and PR is

$$[3(x - 2) - (y - 1)][(x - 2) + 3(y - 1)] = 0$$

$$\Rightarrow 3(x - 2)^2 - 3(y - 1)^2 + 8(x - 2)(y - 1) = 0$$

$$\Rightarrow 3x^2 - 3y^2 + 8xy - 20x - 10y + 25 = 0$$

16

Circle

Topic 1 Equation of Circle

Objective Questions I (Only one correct option)

- A circle touching the X -axis at $(3, 0)$ and making a intercept of length 8 on the Y -axis passes through the point
(2019 Main, 12 April II)
(a) $(3, 10)$ (b) $(3, 5)$
(c) $(2, 3)$ (d) $(1, 5)$
- Let $O(0, 0)$ and $A(0, 1)$ be two fixed points, then the locus of a point P such that the perimeter of ΔAOP is 4, is
(2019 Main, 8 April II)
(a) $8x^2 - 9y^2 + 9y = 18$ (b) $9x^2 - 8y^2 + 8y = 16$
(c) $9x^2 + 8y^2 - 8y = 16$ (d) $8x^2 + 9y^2 - 9y = 18$
- If a circle of radius R passes through the origin O and intersects the coordinate axes at A and B , then the locus of the foot of perpendicular from O on AB is
(2019 Main, 12 Jan II)
(a) $(x^2 + y^2)^2 = 4R^2x^2y^2$
(b) $(x^2 + y^2)^3 = 4R^2x^2y^2$
(c) $(x^2 + y^2)(x + y) = R^2xy$
(d) $(x^2 + y^2)^2 = 4R^2y^2$
- A square is inscribed in the circle $x^2 + y^2 - 6x + 8y - 103 = 0$ with its sides parallel to the coordinate axes. Then, the distance of the vertex of this square which is nearest to the origin is
(2019 Main, 11 Jan II)
(a) 6 (b) 13 (c) $\sqrt{41}$ (d) $\sqrt{137}$
- If the area of an equilateral triangle inscribed in the circle, $x^2 + y^2 + 10x + 12y + c = 0$ is $27\sqrt{3}$ sq units, then c is equal to
(2019 Main, 10 Jan II)
(a) 20 (b) -25 (c) 13 (d) 25
- Let the orthocentre and centroid of a triangle be $A(-3, 5)$ and $B(3, 3)$, respectively. If C is the circumcentre of this triangle, then the radius of the circle having line segment AC as diameter, is
(2018 Main)
(a) $\sqrt{10}$ (b) $2\sqrt{10}$ (c) $3\sqrt{\frac{5}{2}}$ (d) $\frac{3\sqrt{5}}{2}$
- The centre of circle inscribed in square formed by the lines $x^2 - 8x + 12 = 0$ and $y^2 - 14y + 45 = 0$, is
(2003, 1M)
(a) $(4, 7)$ (b) $(7, 4)$
(c) $(9, 4)$ (d) $(4, 9)$
- Let AB be a chord of the circle $x^2 + y^2 = r^2$ subtending a right angle at the centre. Then, the locus of the centroid of the ΔPAB as P moves on the circle, is
(2001, 1M)
(a) a parabola (b) a circle
(c) an ellipse (d) a pair of straight lines
- The lines $2x - 3y = 5$ and $3x - 4y = 7$ are diameters of a circle of area 154 sq units. Then, the equation of this circle is
(1989, 2M)
(a) $x^2 + y^2 + 2x - 2y = 62$ (b) $x^2 + y^2 + 2x - 2y = 47$
(c) $x^2 + y^2 - 2x + 2y = 47$ (d) $x^2 + y^2 - 2x + 2y = 62$
- AB is a diameter of a circle and C is any point on the circumference of the circle. Then,
(1983, 1M)
(a) the area of ΔABC is maximum when it is isosceles
(b) the area of ΔABC is minimum when it is isosceles
(c) the perimeter of ΔABC is minimum when it is isosceles
(d) None of the above
- The centre of the circle passing through the point $(0, 1)$ and touching the curve $y = x^2$ at $(2, 4)$ is
(1983, 1M)
(a) $\left(-\frac{16}{5}, \frac{27}{10}\right)$ (b) $\left(-\frac{16}{7}, \frac{53}{10}\right)$
(c) $\left(-\frac{16}{5}, \frac{53}{10}\right)$ (d) None of these

Objective Questions II

(One or more than one correct option)

- Circle(s) touching X -axis at a distance 3 from the origin and having an intercept of length $2\sqrt{7}$ on Y -axis is/are
(2013 Adv.)
(a) $x^2 + y^2 - 6x + 8y + 9 = 0$
(b) $x^2 + y^2 - 6x + 7y + 9 = 0$
(c) $x^2 + y^2 - 6x - 8y + 9 = 0$
(d) $x^2 + y^2 - 6x - 7y + 9 = 0$
- Let L_1 be a straight line passing through the origin and L_2 be the straight line $x + y = 1$. If the intercepts made by the circle $x^2 + y^2 - x + 3y = 0$ on L_1 and L_2 are equal, then which of the following equation can represent L_1 ?
(1999, 1M)
(a) $x + y = 0$ (b) $x - y = 0$
(c) $x + 7y = 0$ (d) $x - 7y = 0$

406 Circle

Fill in the Blanks

14. The lines $3x - 4y + 4 = 0$ and $6x - 8y - 7 = 0$ tangents to the same circle. The radius of this circle is... (1984, 2M)
15. If A and B are points in the plane such that $PA/PB = k$ (constant) for all P on a given circle, then the value of k cannot be equal to (1982, 2M)

True/False

16. The line $x + 3y = 0$ is a diameter of the circle $x^2 + y^2 - 6x + 2y = 0$. (1989, 1M)

Analytical & Descriptive Questions

17. Let C be any circle with centre $(0, \sqrt{2})$. Prove that at most two rational points can be there on C .
(A rational point is a point both of whose coordinates are rational numbers.) (1997, 5M)
18. Consider a curve $ax^2 + 2hxy + by^2 = 1$ and a point P not on the curve. A line drawn from the point P intersect the curve at points Q and R . If the product $PQ \cdot QR$ is independent of the slope of the line, then show that the curve is a circle. (1997, 5M)
19. A circle passes through three points A, B and C with the line segment AC as its diameter. A line passing through A intersects the chord BC at a point D inside the circle. If angles DAB and CAB are α and β respectively and the distance between the point A and the mid-point of the line segment DC is d , prove that the area of the circle is
$$\frac{\pi d^2 \cos^2 \alpha}{\cos^2 \alpha + \cos^2 \beta + 2 \cos \alpha \cos \beta \cos(\beta - \alpha)}$$
 (1996, 5M)
20. If $(m_i, 1/m_i), m_i > 0, i = 1, 2, 3, 4$ are four distinct points on a circle, then show that $m_1 m_2 m_3 m_4 = 1$. (1989, 2M)
21. The abscissae of the two points A and B are the roots of the equation $x^2 + 2ax - b^2 = 0$ and their ordinates are the roots of the equation $y^2 + 2py - q^2 = 0$. Find the equation and the radius of the circle with AB as diameter. (1984, 4M)

Topic 2 Relation between Two Circles

Objective Questions I (Only one correct option)

1. If the circles $x^2 + y^2 + 5Kx + 2y + K = 0$ and $2(x^2 + y^2) + 2Kx + 3y - 1 = 0, (K \in R)$, intersect at the points P and Q , then the line $4x + 5y - K = 0$ passes through P and Q , for (2019 Main, 10 April I)
- (a) no values of K
(b) exactly one value of K
(c) exactly two values of K
(d) infinitely many values of K
2. If a tangent to the circle $x^2 + y^2 = 1$ intersects the coordinate axes at distinct points P and Q , then the locus of the mid-point of PQ is (2019 Main, 9 April I)
- (a) $x^2 + y^2 - 2x^2y^2 = 0$ (b) $x^2 + y^2 - 2xy = 0$
(c) $x^2 + y^2 - 4x^2y^2 = 0$ (d) $x^2 + y^2 - 16x^2y^2 = 0$

Integer & Numerical Answer Type Questions

22. For how many values of p , the circle $x^2 + y^2 + 2x + 4y - p = 0$ and the coordinate axes have exactly three common points? (2017 Adv.)
23. The straight line $2x - 3y = 1$ divide the circular region $x^2 + y^2 \leq 6$ into two parts. If $S = \left\{ \left(2, \frac{3}{4} \right), \left(\frac{5}{2}, \frac{3}{4} \right), \left(\frac{1}{4}, -\frac{1}{4} \right), \left(\frac{1}{8}, \frac{1}{4} \right) \right\}$, then the number of point (s) in S lying inside the smaller part is (2016 Adv.)

Paragraph Based Questions

Let S be the circle in the XY -plane defined by the equation

$$x^2 + y^2 = 4. \quad (2018 Adv.)$$

(There are two questions based on above Paragraph, the question given below is one of them)

24. Let E_1E_2 and F_1F_2 be the chords of S passing through the point $P_0(1, 1)$ and parallel to the X -axis and the Y -axis, respectively. Let G_1G_2 be the chord of S passing through P_0 and having slope -1 . Let the tangents to S at E_1 and E_2 meet at E_3 , then tangents to S at F_1 and F_2 meet at F_3 , and the tangents to S at G_1 and G_2 meet at G_3 . Then, the points E_3, F_3 and G_3 lie on the curve
- (a) $x + y = 4$
(b) $(x - 4)^2 + (y - 4)^2 = 16$
(c) $(x - 4)(y - 4) = 4$
(d) $xy = 4$
25. Let P be a point on the circle S with both coordinates being positive. Let the tangent to S at P intersect the coordinate axes at the points M and N . Then, the mid-point of the line segment MN must lie on the curve
- (a) $(x + y)^2 = 3xy$
(b) $x^{2/3} + y^{2/3} = 2^{2/3}$
(c) $x^2 + y^2 = 2xy$
(d) $x^2 + y^2 = x^2y^2$

3. If a variable line, $3x + 4y - \lambda = 0$ is such that the two circles $x^2 + y^2 - 2x - 2y + 1 = 0$ and $x^2 + y^2 - 18x - 2y + 78 = 0$ are on its opposite sides, then the set of all values of λ is the interval (2019 Main, 12 Jan I)
- (a) $[13, 23]$ (b) $(2, 17)$
(c) $[12, 21]$ (d) $(23, 31)$
4. Let C_1 and C_2 be the centres of the circles $x^2 + y^2 - 2x - 2y - 2 = 0$ and $x^2 + y^2 - 6x - 6y + 14 = 0$ respectively. If P and Q are the points of intersection of the two circles, then the area (in sq units) of the quadrilateral PC_1QC_2 is (2019 Main, 12 Jan I)
- (a) 8 (b) 4
(c) 6 (d) 9

5. If the circles $x^2 + y^2 - 16x - 20y + 164 = r^2$ and $(x - 4)^2 + (y - 7)^2 = 36$ intersect at two distinct points, then
(2019 Main, 9 Jan II)
- (a) $0 < r < 1$ (b) $r > 11$
(c) $1 < r < 11$ (d) $r = 11$
6. If one of the diameters of the circle, given by the equation, $x^2 + y^2 - 4x + 6y - 12 = 0$, is a chord of a circle S , whose centre is at $(-3, 2)$, then the radius of S is
(2016 Main)
- (a) $5\sqrt{2}$ (b) $5\sqrt{3}$ (c) 5 (d) 10
7. If one of the diameters of the circle $x^2 + y^2 - 2x - 6y + 6 = 0$ is a chord to the circle with centre $(2, 1)$, then the radius of the circle is (2004, 1M)
- (a) $\sqrt{3}$ (b) $\sqrt{2}$ (c) 3 (d) 2
8. The number of common tangents to the circles $x^2 + y^2 - 4x - 6y - 12 = 0$ and $x^2 + y^2 + 6x + 18y + 26 = 0$ is
(2015)
- (a) 1 (b) 2 (c) 3 (d) 4
9. Let C be the circle with centre at $(1, 1)$ and radius 1. If T is the circle centred at $(0, y)$ passing through origin and touching the circle C externally, then the radius of T is equal to
(2014 Main)
- (a) $\frac{\sqrt{3}}{\sqrt{2}}$ (b) $\frac{\sqrt{3}}{2}$ (c) $\frac{1}{2}$ (d) $\frac{1}{4}$
10. If the circle $x^2 + y^2 + 2x + 2ky + 6 = 0$ and $x^2 + y^2 + 2ky + k = 0$ intersect orthogonally, then k is
(2000, 2M)
- (a) 2 or $-3/2$ (b) -2 or $-3/2$ (c) 2 or $3/2$ (d) -2 or $3/2$
11. The ΔPQR is inscribed in the circle $x^2 + y^2 = 25$. If Q and R have coordinates $(3, 4)$ and $(-4, 3)$ respectively, then $\angle QPR$ is equal to
(2000, 2M)
- (a) $\pi/2$ (b) $\pi/3$ (c) $\pi/4$ (d) $\pi/6$
12. The number of common tangents to the circles $x^2 + y^2 = 4$ and $x^2 + y^2 - 6x - 8y = 24$ is
(1998, 2M)
- (a) 0 (b) 1 (c) 3 (d) 4
13. The angle between a pair of tangents drawn from a point P to the circle $x^2 + y^2 + 4x - 6y + 9 \sin^2 \alpha + 13 \cos^2 \alpha = 0$ is 2α . The equation of the locus of the point P is
(1996, 1M)
- (a) $x^2 + y^2 + 4x - 6y + 4 = 0$ (b) $x^2 + y^2 + 4x - 6y - 9 = 0$
(c) $x^2 + y^2 + 4x - 6y - 4 = 0$ (d) $x^2 + y^2 + 4x - 6y + 9 = 0$
14. If the two circles $(x - 1)^2 + (y - 3)^2 = r^2$ and $x^2 + y^2 - 8x + 2y + 8 = 0$ intersect in two distinct points, then
(1989, 2M)
- (a) $2 < r < 8$ (b) $r < 2$ (c) $r = 2$ (d) $r > 2$
15. If a circle passes through the point (a, b) and cuts the circle $x^2 + y^2 = k^2$ orthogonally, then the equation of the locus of its centre is
(1988, 2M)
- (a) $2ax + 2by - (a^2 + b^2 + k^2) = 0$
(b) $2ax + 2by - (a^2 - b^2 + k^2) = 0$
(c) $x^2 + y^2 - 3ax - 4by + a^2 + b^2 - k^2 = 0$
(d) $x^2 + y^2 - 2ax - 3by + (a^2 - b^2 - k^2) = 0$

Objective Questions II

(One or more than one correct option)

16. Let T be the line passing through the points $P(-2, 7)$ and $Q(2, -5)$. Let F_1 be the set of all pairs of circles (S_1, S_2) such that T is tangent to S_1 at P and tangent to S_2 at Q , and also such that S_1 and S_2 touch each other at a point, say M . Let E_1 be the set representing the locus of M as the pair (S_1, S_2) varies in F_1 . Let the set of all straight line segments joining a pair of distinct points of E_1 and passing through the point $R(1, 1)$ be F_2 . Let E_2 be the set of the mid-points of the line segments in the set F_2 . Then, which of the following statement(s) is (are) TRUE?
(2018 Adv.)
- (a) The point $(-2, 7)$ lies in E_1
(b) The point $(\frac{4}{5}, \frac{7}{5})$ does NOT lie in E_2
(c) The point $(\frac{1}{2}, 1)$ lies in E_2
(d) The point $(0, \frac{3}{2})$ does NOT lie in E_1
17. A circle S passes through the point $(0, 1)$ and is orthogonal to the circles $(x - 1)^2 + y^2 = 16$ and $x^2 + y^2 = 1$. Then,
(2014 Adv.)
- (a) radius of S is 8
(b) radius of S is 7
(c) centre of S is $(-7, 1)$
(d) centre of S is $(-8, 1)$

Passage Based Problems

Passage

Let $ABCD$ be a square of side length 2 unit. C_2 is the circle through vertices A, B, C, D and C_1 is the circle touching all the sides of square $ABCD$. L is the line through A .
(2006, 5M)

18. If P is a point of C_1 and Q is a point on C_2 , then $\frac{PA^2 + PB^2 + PC^2 + PD^2}{QA^2 + QB^2 + QC^2 + QD^2}$ is equal to
- (a) 0.75 (b) 1.25
(c) 1 (d) 0.5
19. A circle touches the line L and the circle C_1 externally such that both the circles are on the same side of the line, then the locus of centre of the circle is
- (a) ellipse (b) hyperbola
(c) parabola (d) parts of straight line
20. A line M through A is drawn parallel to BD . Point S moves such that its distances from the line BD and the vertex A are equal. If locus of S cuts M at T_2 and T_3 and AC at T_1 , then area of $\Delta T_1 T_2 T_3$ is
- (a) $\frac{1}{2}$ sq unit (b) $\frac{2}{3}$ sq unit
(c) 1 sq unit (d) 2 sq units

Match the Columns

21. Match the conditions/expressions in Column I with statement in Column II.

Column I	Column II
A. Two intersecting circles	p. have a common tangent
B. Two mutually external circles	q. have a common normal
C. Two circles, one strictly inside the other	r. do not have a common tangent
D. Two branches of a hyperbola	s. do not have a common normal

Analytical & Descriptive Questions

22. Let C_1 and C_2 be two circles with C_2 lying inside C_1 . A circle C lying inside C_1 touches C_1 internally and C_2 externally. Identify the locus of the centre of C .
(2001, 5M)
23. Three circles touch one another externally. The tangents at their points of contact meet at a point whose distance from a point of contact is 4. Find the ratio of the product of the radii to the sum of the radii of the circles.
(1992, 5M)

Topic 3 Equation of Tangent, Normal and Length of Tangents

Objective Questions I (Only one correct option)

1. A circle touches the Y -axis at the point $(0, 4)$ and passes through the point $(2, 0)$. Which of the following lines is not a tangent to this circle?
(2020 Main, 9 Jan I)
(a) $4x - 3y + 17 = 0$ (b) $3x + 4y - 6 = 0$
(c) $4x + 3y - 8 = 0$ (d) $3x - 4y - 24 = 0$
2. The common tangent to the circles $x^2 + y^2 = 4$ and $x^2 + y^2 + 6x + 8y - 24 = 0$ also passes through the point
(2019 Main, 9 April II)
(a) $(6, -2)$ (b) $(4, -2)$
(c) $(-6, 4)$ (d) $(-4, 6)$
3. A rectangle is inscribed in a circle with a diameter lying along the line $3y = x + 7$. If the two adjacent vertices of the rectangle are $(-8, 5)$ and $(6, 5)$, then the area of the rectangle (in sq units) is
(2019 Main, 9 April II)
(a) 72 (b) 84 (c) 98 (d) 56
4. The tangent and the normal lines at the point $(\sqrt{3}, 1)$ to the circle $x^2 + y^2 = 4$ and the X -axis form a triangle. The area of this triangle (in square units) is
(2019 Main, 8 April II)
(a) $\frac{1}{3}$ (b) $\frac{4}{\sqrt{3}}$ (c) $\frac{2}{\sqrt{3}}$ (d) $\frac{1}{\sqrt{3}}$
5. The straight line $x + 2y = 1$ meets the coordinate axes at A and B . A circle is drawn through A, B and the origin. Then, the sum of perpendicular distances from A and B on the tangent to the circle at the origin is
(2019 Main, 11 Jan I)
(a) $2\sqrt{5}$ (b) $\frac{\sqrt{5}}{4}$ (c) $4\sqrt{5}$ (d) $\frac{\sqrt{5}}{2}$
6. If a circle C passing through the point $(4, 0)$ touches the circle $x^2 + y^2 + 4x - 6y = 12$ externally at the point $(1, -1)$, then the radius of C is
(2019 Main, 10 Jan I)
(a) 5 (b) $2\sqrt{5}$ (c) $\sqrt{57}$ (d) 4
7. If the tangent at $(1, 7)$ to the curve $x^2 = y - 6$ touches the circle $x^2 + y^2 + 16x + 12y + c = 0$, then the value of c is
(2018 Main)
(a) 195 (b) 185 (c) 85 (d) 95

8. Let $ABCD$ be a quadrilateral with area 18, with side AB parallel to the side CD and $AB = 2CD$. Let AD be perpendicular to AB and CD . If a circle is drawn inside the quadrilateral $ABCD$ touching all the sides, then its radius is
(2007, 3M)
(a) 3 (b) 2 (c) $\frac{3}{2}$ (d) 1
9. If the tangent at the point P on the circle $x^2 + y^2 + 6x + 6y = 2$ meets the straight line $5x - 2y + 6 = 0$ at a point Q on the Y -axis, then the length of PQ is
(2002, 1M)
(a) 4 (b) $2\sqrt{5}$ (c) 5 (d) $3\sqrt{5}$
10. Let PQ and RS be tangents at the extremities of the diameter PR of a circle of radius r . If PS and RQ intersect at a point X on the circumference of the circle, then $2r$ equals
(2001, 1M)
(a) $\sqrt{PQ \cdot RS}$
(b) $\frac{PQ + RS}{2}$
(c) $\frac{2PQ \cdot RS}{PQ + RS}$
(d) $\sqrt{\frac{PQ^2 + RS^2}{2}}$

Objective Questions II

(One or more than one correct option)

11. Let RS be the diameter of the circle $x^2 + y^2 = 1$, where S is the point $(1, 0)$. Let P be a variable point (other than R and S) on the circle and tangents to the circle at S and P meet at the point Q . The normal to the circle at P intersects a line drawn through Q parallel to RS at point E . Then, the locus of E passes through the point(s)
(2016 Adv.)
(a) $\left(\frac{1}{3}, \frac{1}{\sqrt{3}}\right)$ (b) $\left(\frac{1}{4}, \frac{1}{2}\right)$
(c) $\left(\frac{1}{3}, -\frac{1}{\sqrt{3}}\right)$ (d) $\left(\frac{1}{4}, -\frac{1}{2}\right)$

12. The circle $C_1 : x^2 + y^2 = 3$ with centre at O intersects the parabola $x^2 = 2y$ at the point P in the first quadrant. Let the tangent to the circle C_1 at P touches other two circles C_2 and C_3 at R_2 and R_3 , respectively. Suppose C_2 and C_3 have equal radii $2\sqrt{3}$ and centres Q_2 and Q_3 , respectively. If Q_2 and Q_3 lie on the Y -axis, then
- (a) $Q_2Q_3 = 12$ (2016 Adv.)
 - (b) $R_2R_3 = 4\sqrt{6}$
 - (c) area of the ΔOR_2R_3 is $6\sqrt{2}$
 - (d) area of the ΔPQ_2Q_3 is $4\sqrt{2}$

Assertion and Reason

13. Tangents are drawn from the point $(17, 7)$ to the circle $x^2 + y^2 = 169$.
- Statement I** The tangents are mutually perpendicular. because
- Statement II** The locus of the points from which a mutually perpendicular tangents can be drawn to the given circle is $x^2 + y^2 = 338$. (2007, 3M)
- (a) Statement I is true, Statement II is true; Statement II is correct explanation of Statement I
 - (b) Statement I is true, Statement II is true, Statement II is not correct explanation of Statement I.
 - (c) Statement I is true, Statement II is false.
 - (d) Statement I is false, Statement II is true.

Passage Based Problems

Passage 1

A tangent PT is drawn to the circle $x^2 + y^2 = 4$ at the point $P(\sqrt{3}, 1)$. A straight line L , perpendicular to PT is a tangent to the circle $(x - 3)^2 + y^2 = 1$. (2012)

14. A possible equation of L is
- (a) $x - \sqrt{3}y = 1$
 - (b) $x + \sqrt{3}y = 1$
 - (c) $x - \sqrt{3}y = -1$
 - (d) $x - \sqrt{3}y = 5$
15. A common tangent of the two circles is
- (a) $x = 4$
 - (b) $y = 2$
 - (c) $x + \sqrt{3}y = 4$
 - (d) $x + 2\sqrt{2}y = 6$

Passage 2

A circle C of radius 1 is inscribed in an equilateral ΔPQR . The points of contact of C with the sides PQ, QR, RP are D, E, F respectively. The line PQ is given by the equation $\sqrt{3}x + y - 6 = 0$ and the point D is $\left(\frac{3\sqrt{3}}{2}, \frac{3}{2}\right)$. Further, it is given that the origin and the centre of C are on the same side of the line PQ . (2008, 12M)

16. The equation of circle C is
- (a) $(x - 2\sqrt{3})^2 + (y - 1)^2 = 1$
 - (b) $(x - 2\sqrt{3})^2 + \left(y + \frac{1}{2}\right)^2 = 1$
 - (c) $(x - \sqrt{3})^2 + (y + 1)^2 = 1$
 - (d) $(x - \sqrt{3})^2 + (y - 1)^2 = 1$

17. Points E and F are given by
- (a) $\left(\frac{\sqrt{3}}{2}, \frac{3}{2}\right), (\sqrt{3}, 0)$
 - (b) $\left(\frac{\sqrt{3}}{2}, \frac{1}{2}\right), (\sqrt{3}, 0)$
 - (c) $\left(\frac{\sqrt{3}}{2}, \frac{3}{2}\right), \left(\frac{\sqrt{3}}{2}, \frac{1}{2}\right)$
 - (d) $\left(\frac{3}{2}, \frac{\sqrt{3}}{2}\right), \left(\frac{\sqrt{3}}{2}, \frac{1}{2}\right)$
18. Equations of the sides QR, RP are
- (a) $y = \frac{2}{\sqrt{3}}x + 1, y = -\frac{2}{\sqrt{3}}x - 1$
 - (b) $y = \frac{1}{\sqrt{3}}x, y = 0$
 - (c) $y = \frac{\sqrt{3}}{2}x + 1, y = -\frac{\sqrt{3}}{2}x - 1$
 - (d) $y = \sqrt{3}x, y = 0$

Fill in the Blanks

19. A circle is inscribed in an equilateral triangle of side a . The area of any square inscribed in this circle is... (1994, 2M)
20. If a circle passes through the points of intersection of the coordinate axes with the lines $\lambda x - y + 1 = 0$ and $x - 2y + 3 = 0$, then the value of λ is ... (1991, 2M)

Analytical & Descriptive Questions

21. Find the equation of circle touching the line $2x + 3y + 1 = 0$ at the point $(1, -1)$ and is orthogonal to the circle which has the line segment having end points $(0, -1)$ and $(-2, 3)$ as the diameter. (2004, 4M)
22. Find the coordinates of the point at which the circles $x^2 - y^2 - 4x - 2y + 4 = 0$ and $x^2 + y^2 - 12x - 8y + 36 = 0$ touch each other. Also, find equations of common tangents touching the circles the distinct points. (1993, 5M)
23. Two circles, each of radius 5 units, touch each other at $(1, 2)$. If the equation of their common tangent is $4x + 3y = 10$, find the equations of the circles. (1991, 4M)

Integer & Numerical Answer Type Questions

24. Let the point B be the reflection of the point $A(2, 3)$ with respect to the line $8x - 6y - 23 = 0$. Let Γ_A and Γ_B be circles of radii 2 and 1 with centres A and B respectively. Let T be a common tangent to the circles Γ_A and Γ_B such that both the circles are on the same side of T . If C is the point of intersection of T and the line passing through A and B , then the length of the line segment AC is (2019 Adv.)
25. The centres of two circles C_1 and C_2 each of unit radius are at a distance of 6 units from each other. Let P be the mid-point of the line segment joining the centres of C_1 and C_2 and C be a circle touching circles C_1 and C_2 externally. If a common tangents to C_1 and C passing through P is also a common tangent to C_2 and C , then the radius of the circle C is ... (2009)

Topic 4 Radical Axis and Family of Circle

Objective Questions I (Only one correct option)

- The locus of the centres of the circles, which touch the circle, $x^2 + y^2 = 1$ externally, also touch the Y-axis and lie in the first quadrant, is (2019 Main, 10 April II)
 - $y = \sqrt{1+2x}, x \geq 0$
 - $y = \sqrt{1+4x}, x \geq 0$
 - $x = \sqrt{1+2y}, y \geq 0$
 - $x = \sqrt{1+4y}, y \geq 0$
- The line $x = y$ touches a circle at the point (1, 1). If the circle also passes through the point (1, -3), then its radius is (2019 Main, 10 April I)
 - $3\sqrt{2}$
 - $2\sqrt{2}$
 - 2
 - 3
- Two circles with equal radii are intersecting at the points (0, 1) and (0, -1). The tangent at the point (0, 1) to one of the circles passes through the centre of the other circle. Then, the distance between the centres of these circles is (2019 Main, 11 Jan I)
 - $\sqrt{2}$
 - $2\sqrt{2}$
 - 1
 - 2
- Three circles of radii a, b, c ($a < b < c$) touch each other externally. If they have X-axis as a common tangent, then (2019 Main, 9 Jan I)
 - a, b, c are in AP
 - $\frac{1}{\sqrt{a}} = \frac{1}{\sqrt{b}} + \frac{1}{\sqrt{c}}$
 - $\sqrt{a}, \sqrt{b}, \sqrt{c}$ are in AP
 - $\frac{1}{\sqrt{b}} = \frac{1}{\sqrt{a}} + \frac{1}{\sqrt{c}}$
- The circle passing through (1, -2) and touching the axis of x at (3, 0) also passes through the point (2013 Main)
 - (-5, 2)
 - (2, -5)
 - (5, -2)
 - (-2, 5)
- The circle passing through the point (-1, 0) and touching the Y-axis at (0, 2) also passes through the point (2011)
 - $\left(-\frac{3}{2}, 0\right)$
 - $\left(-\frac{5}{2}, 2\right)$
 - $\left(-\frac{3}{2}, \frac{5}{2}\right)$
 - (-4, 0)
- The locus of the centre of circle which touches $(y-1)^2 + x^2 = 1$ externally and also touches X-axis, is (2005, 2M)
 - $\{x^2 = 4y, y \geq 0\} \cup \{(0, y), y < 0\}$
 - $x^2 = y$
 - $y = 4x^2$
 - $y^2 = 4x \cup (0, y), y \in R$
- If two distinct chords, drawn from the point (p, q) on the circle $x^2 + y^2 = px + qy$ (where, $pq \neq 0$) are bisected by the X-axis, then (1999, 2M)
 - $p^2 = q^2$
 - $p^2 = 8q^2$
 - $p^2 < 8q^2$
 - $p^2 > 8q^2$
- The locus of the centre of a circle, which touches externally the circle $x^2 + y^2 - 6x - 6y + 14 = 0$ and also touches the Y-axis, is given by the equation (1993, 1M)
 - $x^2 - 6x - 10y + 14 = 0$
 - $x^2 - 10x - 6y + 14 = 0$
 - $y^2 - 6x - 10y + 14 = 0$
 - $y^2 - 10x - 6y + 14 = 0$
- The centre of a circle passing through the points (0, 0), (1, 0) and touching the circle $x^2 + y^2 = 9$ is (1992, 2M)
 - $(3/2, 1/2)$
 - $(1/2, 3/2)$
 - $(1/2, 1/2)$
 - $(1/2, -2^{1/2})$

- The equation of the circle passing through (1, 1) and the points of intersection of $x^2 + y^2 + 13x - 3y = 0$ and $2x^2 + 2y^2 + 4x - 7y - 25 = 0$ is (1983, 1M)
 - $4x^2 + 4y^2 - 30x - 10y = 25$
 - $4x^2 + 4y^2 + 30x - 13y - 25 = 0$
 - $4x^2 + 4y^2 - 17x - 10y + 25 = 0$
 - None of the above
- Two circles $x^2 + y^2 = 6$ and $x^2 + y^2 - 6x + 8 = 0$ are given. Then the equation of the circle through their points of intersection and the point (1, 1) is (1980, 1M)
 - $x^2 + y^2 - 6x + 4 = 0$
 - $x^2 + y^2 - 3x + 1 = 0$
 - $x^2 + y^2 - 4y + 2 = 0$
 - None of these

Fill in the Blanks

- For each natural number k . Let C_k denotes the circle with radius k centimetres and centre at origin. On the circle C_k a particle moves k centimetres in the counter-clockwise direction. After completing its motion on C_k the particle moves to C_{k+1} in the radial direction. The motion of the particle continue in this manner. The particle starts at (1, 0). If the particle crosses the positive direction of the X-axis for the first time on the circle C_n , then $n = \dots$ (1997, 2M)
- The intercept on the line $y = x$ by the circle $x^2 + y^2 - 2x = 0$ is AB . Equation of the circle with AB as a diameter is... (1996, 1M)
- If the circle $C_1 : x^2 + y^2 = 16$ intersects another circle C_2 of radius 5 in such a manner that the common chord is of maximum length and has a slope equal to $3/4$, then the coordinates of the centre of C_2 are... (1988, 2M)
- The points of intersection of the line $4x - 3y - 10 = 0$ and the circle $x^2 + y^2 - 2x + 4y - 20 = 0$ are...and...(1983, 2M)

Analytical & Descriptive Questions

- Consider the family of circles $x^2 + y^2 = r^2, 2 < r < 5$. If in the first quadrant, the common tangent to a circle of this family and the ellipse $4x^2 + 25y^2 = 100$ meets the coordinate axes at A and B , then find the equation of the locus of the mid-points of AB . (1999, 5M)
- Consider a family of circles passing through two fixed points $A(3, 7)$ and $B(6, 5)$. Show that the chords in which the circle $x^2 + y^2 - 4x - 6y - 3 = 0$ cuts the members of the family are concurrent at a point. Find the coordinates of this point. (1993, 5M)
- A circle touches the line $y = x$ at a point P such that $OP = 4\sqrt{2}$, where O is the origin. The circle contains the point $(-10, 2)$ in its interior and the length of its chord on the line $x + y = 0$ is $6\sqrt{2}$. Determine the equation of the circle. (1990, 5M)
- Let $S \equiv x^2 + y^2 + 2gx + 2fy + c = 0$ be a given circle. Find the locus of the foot of the perpendicular drawn from the origin upon any chord of S which subtends a right angle at the origin. (1988, 5M)

21. Let a given line L_1 intersect the X and Y -axes at P and Q respectively. Let another line L_2 , perpendicular to L_1 , cut the X and Y -axes at R and S , respectively. Show that the locus of the point of intersection of the line PS and QR is a circle passing through the origin. (1987, 3M)
22. Find the equations of the circles passing through $(-4, 3)$ and touching the lines $x + y = 2$ and $x - y = 2$. (1982, 3M)
23. Find the equation of the circle which passes through the point $(2, 0)$ and whose centre is the limit of the point of intersection of the lines $3x + 5y = 1$, $(2 + c)x + 5c^2y = 1$ as c tends to 1. (1979, 3M)

Topic 5 Equation of Chord Bisected at a Point, Product of Pair of Tangents, Chord of Contact of Tangents, Pole and Equation of Polar

Objective Questions I (Only one correct option)

1. A line $y = mx + 1$ intersects the circle $(x - 3)^2 + (y + 2)^2 = 25$ at the points P and Q . If the midpoint of the line segment PQ has x -coordinate $-\frac{3}{5}$, then which one of the following options is correct?
 (a) $6 \leq m < 8$ (b) $-3 \leq m < -1$ (2019 Adv.)
 (c) $4 \leq m < 6$ (d) $2 \leq m < 4$
2. If the angle of intersection at a point where the two circles with radii 5 cm and 12 cm intersect is 90° , then the length (in cm) of their common chord is (2019 Main, 12 April I)
 (a) $\frac{13}{5}$ (b) $\frac{120}{13}$ (c) $\frac{60}{13}$ (d) $\frac{13}{2}$
3. The sum of the squares of the lengths of the chords intercepted on the circle, $x^2 + y^2 = 16$, by the lines, $x + y = n$, $n \in N$, where N is the set of all natural numbers, is (2019, Main, 8 April I)
 (a) 320 (b) 105
 (c) 160 (d) 210
4. The centres of those circles which touch the circle, $x^2 + y^2 - 8x - 8y - 4 = 0$, externally and also touch the X -axis, lie on (2016 Main)
 (a) a circle
 (b) an ellipse which is not a circle
 (c) a hyperbola
 (d) a parabola
5. The locus of the mid-point of the chord of contact of tangents drawn from points lying on the straight line $4x - 5y = 20$ to the circle $x^2 + y^2 = 9$ is (2012)
 (a) $20(x^2 + y^2) - 36x + 45y = 0$
 (b) $20(x^2 + y^2) + 36x - 45y = 0$
 (c) $36(x^2 + y^2) - 20y + 45y = 0$
 (d) $36(x^2 + y^2) + 20x - 45y = 0$
6. Tangents drawn from the point $P(1, 8)$ to the circle $x^2 + y^2 - 6x - 4y - 11 = 0$ touch the circle at the points A and B . The equation of the circumcircle of the ΔPAB is (2009)
 (a) $x^2 + y^2 + 4x - 6y + 19 = 0$
 (b) $x^2 + y^2 - 4x - 10y + 19 = 0$
 (c) $x^2 + y^2 - 2x + 6y - 29 = 0$
 (d) $x^2 + y^2 - 6x - 4y + 19 = 0$

7. The locus of the mid-point of a chord of the circle $x^2 + y^2 = 4$ which subtends a right angle at the origin, is (1984, 2M)
 (a) $x + y = 2$
 (b) $x^2 + y^2 = 1$
 (c) $x^2 + y^2 = 2$
 (d) $x + y = 1$

Objective Question II

(One or more than one correct option)

8. The equations of the tangents drawn from the origin to the circle $x^2 + y^2 + 2rx + 2hy + h^2 = 0$, are (1988, 2M)
 (a) $x = 0$
 (b) $y = 0$
 (c) $(h^2 - r^2)x - 2rhy = 0$
 (d) $(h^2 - r^2)x + 2rhy = 0$

Assertion and Reason

For the following questions, choose the correct answer from the codes (a), (b), (c) and (d) defined as follows.

- (a) Statement I is true, Statement II is also true; Statement II is the correct explanation of Statement I.
 (b) Statement I is true, Statement II is also true; Statement II is not the correct explanation of Statement I
 (c) Statement I is true; Statement II is false
 (d) Statement I is false; Statement II is true
9. Consider $L_1 : 2x + 3y + p - 3 = 0$
 $L_2 : 2x + 3y + p + 3 = 0$
 where, p is a real number and
 $C : x^2 + y^2 - 6x + 10y + 30 = 0$
Statement I If line L_1 is a chord of circle C , then line L_2 is not always a diameter of circle C .
Statement II If line L_1 is a diameter of circle C , then line L_2 is not a chord of circle C . (2008, 3M)

Fill in the Blanks

10. The chords of contact of the pair of tangents drawn from each point on the line $2x + y = 4$ to the circle $x^2 + y^2 = 1$ pass through the point... (1997, 2M)

412 Circle

11. The equation of the locus of the mid-points of the chords of the circle $4x^2 + 4y^2 - 12x + 4y + 1 = 0$ that subtend an angle of $2\pi/3$ at its centre is ... (1993, 2M)
12. The area of the triangle formed by the tangents from the point $(4, 3)$ to the circle $x^2 + y^2 = 9$ and the line joining their points of contact is... (1987, 2M)
13. From the point $A(0, 3)$ on the circle $x^2 + 4x + (y - 3)^2 = 0$, a chord AB is drawn and extended to a point M such that $AM = 2AB$. The equation of the locus of M is.... (1986, 2M)
14. The equation of the line passing through the points of intersection of the circles $3x^2 + 3y^2 - 2x + 12y - 9 = 0$ and $x^2 + y^2 + 6x + 2y - 15 = 0$ is... (1986, 2M)
15. Let $x^2 + y^2 - 4x - 2y - 11 = 0$ be a circle. A pair of tangents from the point $(4, 5)$ with a pair of radii form a quadrilateral of area... (1985, 2M)
16. From the origin chords are drawn to the circle $(x - 1)^2 + y^2 = 1$. The equation of the locus of the mid-points of these chords is... (1985, 2M)

Analytical & Descriptive Questions

17. Let $2x^2 + y^2 - 3xy = 0$ be the equation of a pair of tangents drawn from the origin O to a circle of radius 3 with centre in the first quadrant. If A is one of the points of contact, find the length of OA . (2001, 5M)
18. Let T_1, T_2 and be two tangents drawn from $(-2, 0)$ onto the circle $C: x^2 + y^2 = 1$. Determine the circles touching C and having T_1, T_2 as their pair of tangents. Further, find the equations of all possible common tangents to these circles when taken two at a time. (1999, 10M)
19. C_1 and C_2 are two concentric circles, the radius of C_2 being twice that of C_1 . From a point P on C_2 , tangents PA and PB are drawn to C_1 . Prove that the centroid of the ΔPAB lies on C_1 . (1998, 8M)

20. Find the intervals of values of a for which the line $y + x = 0$ bisects two chords drawn from a point $\left(\frac{1 + \sqrt{2}a}{2}, \frac{1 - \sqrt{2}a}{2}\right)$ to the circle $2x^2 + 2y^2 - (1 + \sqrt{2}a)x - (1 - \sqrt{2}a)y = 0$. (1996, 6M)
21. Let a circle be given by $2x(x - a) + y(2y - b) = 0, (a \neq 0, b \neq 0)$. Find the condition on a and b if two chords, each bisected by the X -axis can be drawn to the circle from $(a, b/2)$. (1992, 6M)
22. Lines $5x + 12y - 10 = 0$ and $5x - 12y - 40 = 0$ touch a circle C_1 of diameter 6. If the centre of C_1 lies in the first quadrant, find the equation of the circle C_2 which is concentric with C_1 and cuts intercepts of length 8 on these lines. (1986, 5M)
23. Through a fixed point (h, k) secants are drawn to the circle $x^2 + y^2 = r^2$. Show that the locus of the mid-points of the secants intercepted by the circle is $x^2 + y^2 = hx + ky$. (1983, 5M)
24. Let A be the centre of the circle $x^2 + y^2 - 2x - 4y - 20 = 0$. Suppose that, the tangents at the points $B(1, 7)$ and $D(4, -2)$ on the circle meet at the point C . Find the area of the quadrilateral $ABCD$. (1981, 4M)

Integer & Numerical Answer Type Questions

25. Let O be the centre of the circle $x^2 + y^2 = r^2$, where $r > \frac{\sqrt{5}}{2}$. Suppose PQ is a chord of this circle and the equation of the line passing through P and Q is $2x + 4y = 5$. If the centre of the circumcircle of the triangle OPQ lies on the line $x + 2y = 4$, then the value of r is (2020 Adv.)
26. Two parallel chords of a circle of radius 2 are at a distance $\sqrt{3} + 1$ apart. If the chords subtend at the centre, angles of π/k and $\frac{2\pi}{k}$, where $k > 0$, then the value of $[k]$ is..... (2010)
- NOTE** $[k]$ denotes the largest integer less than or equal to k

Answers

Topic 1

- | | | | |
|------------|-------------------|----------------|------------|
| 1. (a) | 2. (c) | 3. (b) | 4. (c) |
| 5. (d) | 6. (c) | 7. (a) | 8. (b) |
| 9. (c) | 10. (d) | 11. (c) | 12. (a, c) |
| 13. (b, c) | 14. $\frac{3}{4}$ | 15. $k \neq 1$ | 16. True |
21. $x^2 + y^2 + 2ax + 2py - (b^2 + q^2) = 0$,
radius = $\sqrt{a^2 + p^2 + b^2 + q^2}$
- | | | | |
|---------|---------|---------|---------|
| 22. (2) | 23. (2) | 24. (a) | 25. (d) |
|---------|---------|---------|---------|

Topic 2

- | | | | |
|--------|---------|---------|---------|
| 1. (a) | 2. (c) | 3. (c) | 4. (b) |
| 5. (c) | 6. (b) | 7. (c) | 8. (c) |
| 9. (d) | 10. (a) | 11. (c) | 12. (b) |

- | | | | |
|------------|---------|---------|------------|
| 13. (d) | 14. (a) | 15. (a) | 16. (a, d) |
| 17. (b, c) | 18. (a) | 19. (c) | 20. (c) |
21. $A \rightarrow p, q; B \rightarrow p, q; C \rightarrow q, r; D \rightarrow q, r$
22. Ellipse having foci are (a, b) and $(0, 0)$
23. $16 : 1$

Topic 3

- | | | | |
|---------|---------|------------------------------|-------------------------------------|
| 1. (c) | 2. (a) | 3. (b) | 4. (c) |
| 5. (d) | 6. (a) | 7. (d) | 8. (b) |
| 9. (c) | 10. (a) | 11. (b, d) | 12. (a, b, c) |
| 13. (c) | 14. (a) | 15. (d) | 16. (d) |
| 17. (a) | 18. (a) | 19. $\frac{a^2}{6}$ -sq unit | 20. $\lambda = 2$ or $-\frac{1}{2}$ |
21. $2x^2 + 2y^2 - 10x - 5y + 1 = 0$

22. $y = 0$ and $7y - 24x + 16 = 0$
 23. $(x - 5)^2 + (y - 5)^2 = 5^2$ and $(x + 3)^2 + (y + 1)^2 = 5^2$
 24. (10) 25. (8)

Topic 4

1. (a) 2. (b) 3. (d) 4. (b)
 5. (c) 6. (d) 7. (a) 8. (d)
 9. (d) 10. (b) 11. (b) 12. (b)
 13. $n = 7$
 14. $x^2 + y^2 - x - y = 0$ 15. $\left(-\frac{9}{5}, \frac{12}{5}\right)$ and $\left(\frac{9}{5}, -\frac{12}{5}\right)$
 16. $(-2, -6)$ and $(4, 2)$ 17. $4x^2 + 25y^2 = 4x^2y^2$
 18. $x = 2$ and $y = 23/3$ 19. $x^2 + y^2 + 18x - 2y + 32 = 0$
 20. $x^2 + y^2 + gx + fy + \frac{c}{2} = 0$
 22. $x^2 + y^2 + 2(10 \pm 3\sqrt{6})x + (55 \pm 24\sqrt{6}) = 0$
 23. $25(x^2 + y^2) - 20x + 2y - 60 = 0$

Topic 5

1. (d) 2. (b) 3. (d) 4. (d)
 5. (a) 6. (b) 7. (c) 8. (a,c)
 9. (c) 10. $\left(\frac{1}{2}, \frac{1}{4}\right)$
 11. $16x^2 + 16y^2 - 48x + 16y + 31 = 0$ 12. $\frac{192}{25}$ sq units
 13. $x^2 + y^2 + 8x - 6y + 9 = 0$ 14. $10x - 3y - 18 = 0$
 15. 8 sq units 16. $x^2 + y^2 - x = 0$
 17. $3(3 + \sqrt{10})$
 18. $\left(x + \frac{4}{3}\right)^2 + y^2 = \left(\frac{1}{3}\right)^2$; $y = \pm \frac{5}{\sqrt{39}}\left(x + \frac{4}{3}\right)$
 20. $a \in (-\infty, -2) \cup (2, \infty)$ 21. $a^2 > 2b^2$
 22. $(x - 5)^2 + (y - 2)^2 = 5^2$ 23. $x^2 + y^2 = hx + ky$
 24. 75 sq units 25. (2) 26. (3)

Hints & Solutions

Topic 1 Equation of Circle

1. It is given that the circle touches the X-axis at $(3, 0)$ and making an intercept of 8 on the Y-axis.

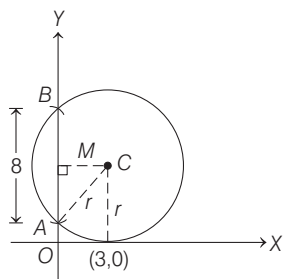

Let the radius of the circle is 'r', then the coordinates of centre of circle are $(3, r)$.

From the figure, we have

$$CM = 3 \Rightarrow CA = \text{radius} = r$$

and $AM = BM = \frac{AB}{2} = 4$

Then, $r^2 = CM^2 + AM^2$
 $= 9 + 16 = 25$

$\Rightarrow r = \pm 5$

Now, the equation of circle having centre $(3, \pm 5)$ and radius = 5 is

$$(x - 3)^2 + (y \pm 5)^2 = 25$$

Now, from the options $(3, 10)$ satisfy the equation of circle

$$(x - 3)^2 + (y - 5)^2 = 25$$

2. Given vertices of ΔAOP are $O(0, 0)$ and $A(0, 1)$

Let the coordinates of point P are (x, y) .

Clearly, perimeter = $OA + AP + OP = 4$ (given)

$$\Rightarrow \sqrt{(0-0)^2 + (0-1)^2} + \sqrt{(0-x)^2 + (1-y)^2} + \sqrt{x^2 + y^2} = 4$$

$$\Rightarrow 1 + \sqrt{x^2 + (y-1)^2} + \sqrt{x^2 + y^2} = 4$$

$$\Rightarrow \sqrt{x^2 + y^2 - 2y + 1} + \sqrt{x^2 + y^2} = 3$$

$$\Rightarrow \sqrt{x^2 + y^2 - 2y + 1} = 3 - \sqrt{x^2 + y^2}$$

$$\Rightarrow x^2 + y^2 - 2y + 1 = 9 + x^2 + y^2 - 6\sqrt{x^2 + y^2}$$

[squaring both sides]

$$\Rightarrow 1 - 2y = 9 - 6\sqrt{x^2 + y^2}$$

$$\Rightarrow 6\sqrt{x^2 + y^2} = 2y + 8$$

$$\Rightarrow 3\sqrt{x^2 + y^2} = y + 4$$

$$\Rightarrow 9(x^2 + y^2) = (y + 4)^2$$
 [squaring both sides]

$$\Rightarrow 9x^2 + 9y^2 = y^2 + 8y + 16$$

$$\Rightarrow 9x^2 + 8y^2 - 8y = 16$$

Thus, the locus of point $P(x, y)$ is

$$9x^2 + 8y^2 - 8y = 16$$

3. Let the foot of perpendicular be $P(h, k)$. Then, the slope of line $OP = \frac{k}{h}$

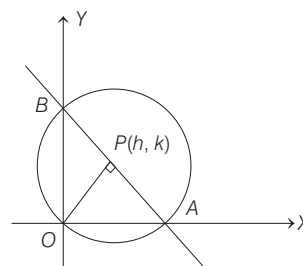

414 Circle

\therefore Line AB is perpendicular to line OP , so slope of line $AB = -\frac{h}{k}$ [\therefore product of slopes of two perpendicular lines is (-1)]

Now, the equation of line AB is

$$y - k = -\frac{h}{k}(x - h) \Rightarrow hx + ky = h^2 + k^2$$

or
$$\frac{x}{\left(\frac{h^2 + k^2}{h}\right)} + \frac{y}{\left(\frac{h^2 + k^2}{k}\right)} = 1$$

So, point $A\left(\frac{h^2 + k^2}{h}, 0\right)$ and $B\left(0, \frac{h^2 + k^2}{k}\right)$

$\therefore \triangle AOB$ is a right angled triangle, so AB is one of the diameter of the circle having radius R (given).

$$\Rightarrow AB = 2R$$

$$\Rightarrow \sqrt{\left(\frac{h^2 + k^2}{h}\right)^2 + \left(\frac{h^2 + k^2}{k}\right)^2} = 2R$$

$$\Rightarrow (h^2 + k^2)^2 \left(\frac{1}{h^2} + \frac{1}{k^2}\right) = 4R^2$$

$$\Rightarrow (h^2 + k^2)^3 = 4R^2 h^2 k^2$$

On replacing h by x and k by y , we get

$$(x^2 + y^2)^3 = 4R^2 x^2 y^2,$$

which is the required locus.

4. Given equation of circle is $x^2 + y^2 - 6x + 8y - 103 = 0$, which can be written as $(x - 3)^2 + (y + 4)^2 = 128 = (8\sqrt{2})^2$
 \therefore Centre = $(3, -4)$ and radius = $8\sqrt{2}$

Now, according to given information, we have the following figure.

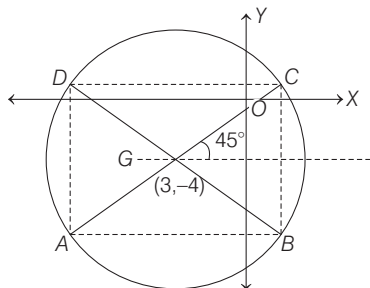

For the coordinates of A and C .

$$\text{Consider, } \frac{x-3}{\frac{1}{\sqrt{2}}} = \frac{y+4}{\frac{1}{\sqrt{2}}} = \pm 8\sqrt{2}$$

[using distance (parametric) form of line,

$$\frac{x-x_1}{\cos\theta} = \frac{y-y_1}{\sin\theta} = r]$$

$$\Rightarrow x = 3 \pm 8, y = -4 \pm 8$$

$$\therefore A(-5, -12) \text{ and } C(11, 4)$$

Similarly, for the coordinates of B and D , consider

$$\frac{x-3}{-\frac{1}{\sqrt{2}}} = \frac{y+4}{\frac{1}{\sqrt{2}}} = \pm 8\sqrt{2} \quad [\text{in this case, } \theta = 135^\circ]$$

$$\Rightarrow x = 3 \mp 8, y = -4 \pm 8$$

$$\therefore B(11, -12) \text{ and } D(-5, 4)$$

$$\text{Now, } OA = \sqrt{25 + 144} = \sqrt{169} = 13;$$

$$OB = \sqrt{121 + 144} = \sqrt{265}$$

$$OC = \sqrt{121 + 16} = \sqrt{137}$$

$$\text{and } OD = \sqrt{25 + 16} = \sqrt{41}$$

5. Clearly, centre of the circumscribed circle is the centroid (G) of the equilateral triangle ABC .

[\therefore in an equilateral triangle circumcentre and centroid coincide]

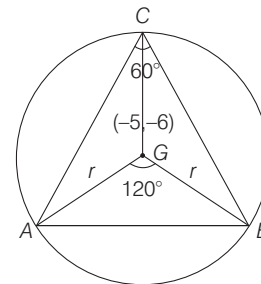

Also, we know that

$$\triangle AGB \cong \triangle BGC \cong \triangle CGA \quad [\text{by SAS congruence rule}]$$

$$\therefore ar(\triangle ABC) = 3 ar(\triangle AGB)$$

$$= 3 \left(\frac{1}{2} r^2 \sin 120^\circ \right)$$

$$[\therefore \text{area of triangle} = \frac{1}{2} ab \sin(\angle C)]$$

$$\therefore ar(\triangle ABC) = 27\sqrt{3} \quad [\text{given}]$$

$$\therefore \frac{3}{2} r^2 \frac{\sqrt{3}}{2} = 27\sqrt{3}$$

$$[\sin 120^\circ = \sin(180^\circ - 60^\circ) = \sin 60^\circ = \frac{\sqrt{3}}{2}]$$

$$\Rightarrow r^2 = 4 \times 9 \Rightarrow r = 6$$

Now, radius of circle,

$$r = \sqrt{g^2 + f^2 - c}$$

$$\Rightarrow 6 = \sqrt{25 + 36 - c}$$

$$[\therefore \text{in the given equation of circle } 2g = 10 \text{ and } 2f = 12 \Rightarrow g = 5 \text{ and } f = 6]$$

$$\Rightarrow 36 = 25 + 36 - c$$

$$\Rightarrow c = 25$$

6. Key idea *Orthocentre, centroid and circumcentre are collinear and centroid divide orthocentre and circumcentre in 2 : 1 ratio.*

We have orthocentre and centroid of a triangle be $A(-3, 5)$ and $B(3, 3)$ respectively and C circumcentre.

$$\text{Clearly, } AB = \sqrt{(3+3)^2 + (3-5)^2} = \sqrt{36+4} = 2\sqrt{10}$$

We know that, $AB : BC = 2 : 1$

$$\Rightarrow BC = \sqrt{10}$$

$$\text{Now, } AC = AB + BC = 2\sqrt{10} + \sqrt{10} = 3\sqrt{10}$$

Since, AC is a diameter of circle.

$$\therefore r = \frac{AC}{2} \Rightarrow r = \frac{3\sqrt{10}}{2} = 3\sqrt{\frac{5}{2}}$$

7. Given, circle is inscribed in square formed by the lines $x^2 - 8x + 12 = 0$ and $y^2 - 14y + 45 = 0$
 $\Rightarrow x = 6$ and $x = 2, y = 5$ and $y = 9$
 which could be plotted as

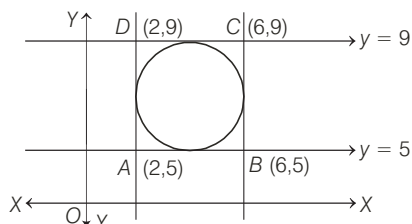

where, $ABCD$ clearly forms a square.

\therefore Centre of inscribed circle
 = Point of intersection of diagonals
 = Mid-point of AC or BD
 $= \left(\frac{2+6}{2}, \frac{5+9}{2}\right) = (4, 7)$

\Rightarrow Centre of inscribed circle is $(4, 7)$.

8. Choosing OA as X -axis, $A = (r, 0), B = (0, r)$ and any point P on the circle is $(r \cos \theta, r \sin \theta)$. If (x, y) is the centroid of ΔPAB , then

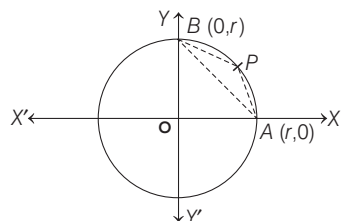

$$3x = r \cos \theta + r + 0 \text{ and } 3y = r \sin \theta + 0 + r$$

$$\therefore (3x - r)^2 + (3y - r)^2 = r^2$$

Hence, locus of P is a circle.

9. Since, $2x - 3y = 5$ and $3x - 4y = 7$ are diameters of a circle.

Their point of intersection is centre $(1, -1)$.

Also given, $\pi r^2 = 154 \Rightarrow r^2 = 154 \times \frac{7}{22} \Rightarrow r = 7$

\therefore Required equation of circle is

$$(x - 1)^2 + (y + 1)^2 = 7^2$$

$$\Rightarrow x^2 + y^2 - 2x + 2y = 47$$

10. Clearly, $\angle C = 90^\circ$ as angle in semi-circle is right angled.

Now, area of triangle is maximum when $AC = BC$.

i.e. Triangle is right angled isosceles.

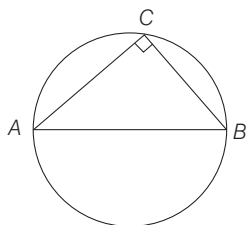

11. Let centre of circle be (h, k) .

so that $OA^2 = OB^2$

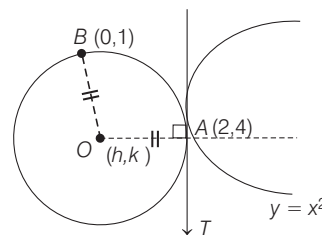

$$\Rightarrow h^2 + (k - 1)^2 = (h - 2)^2 + (k - 4)^2$$

$$\Rightarrow 4h + 6k - 19 = 0 \quad \dots(i)$$

Also, slope of $OA = \frac{k - 4}{h - 2}$ and slope of tangent at $(2, 4)$ to

$y = x^2$ is 4.

and $(\text{slope of } OA) \cdot (\text{slope of tangent at } A) = -1$

$$\therefore \frac{k - 4}{h - 2} \cdot 4 = -1$$

$$\Rightarrow 4k - 16 = -h + 2$$

$$h + 4k = 18 \quad \dots(ii)$$

On solving Eqs. (i) and (ii), we get

$$k = \frac{53}{10} \text{ and } h = -\frac{16}{5}$$

\therefore Centre coordinates are $\left(-\frac{16}{5}, \frac{53}{10}\right)$.

12. PLAN

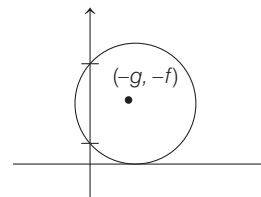

Here, the length of intercept on Y -axis is $\Rightarrow 2\sqrt{f^2 - c}$

and if circle touches X -axis

$$\Rightarrow g^2 = c$$

for $x^2 + y^2 + 2gx + 2fy + c = 0$

Here, $x^2 + y^2 + 2gx + 2fy + c = 0$

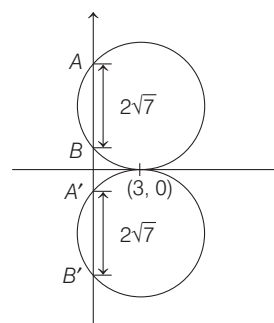

passes through $(3, 0)$.

$$\Rightarrow 9 + 6g + c = 0 \quad \dots(i)$$

$$g^2 = c \quad \dots(ii)$$

and $2\sqrt{f^2 - c} = 2\sqrt{7}$

416 Circle

$$f^2 - c = 7 \quad \dots(\text{iii})$$

From Eqs. (i) and (ii), we get

$$g^2 + 6g + 9 = 0 \Rightarrow (g + 3)^2 = 0$$

$$\Rightarrow g = -3 \text{ and } c = 9$$

$$\therefore f^2 = 16 \Rightarrow f = \pm 4$$

$$\therefore x^2 + y^2 - 6x \pm 8y + 9 = 0$$

- 13.** Let equation of line L_1 be $y = mx$. Intercepts made by L_1 and L_2 on the circle will be equal i.e. L_1 and L_2 are at the same distance from the centre of the circle;

Centre of the given circle is $(1/2, -3/2)$. Therefore,

$$\frac{|1/2 - 3/2 - 1|}{\sqrt{1+1}} = \frac{\left| \frac{m}{2} + \frac{3}{2} \right|}{\sqrt{m^2 - 1}} \Rightarrow \frac{2}{\sqrt{2}} = \frac{|m+3|}{2\sqrt{m^2+1}}$$

$$\Rightarrow 8m^2 + 8 = m^2 + 6m + 9$$

$$\Rightarrow 7m^2 - 6m - 1 = 0 \Rightarrow (7m+1)(m-1) = 0$$

$$\Rightarrow m = -\frac{1}{7}, m = 1$$

Thus, two chords are $x + 7y = 0$

and $x - y = 0$.

Therefore, (b) and (c) are correct answers.

- 14.** Since, $3x - 4y + 4 = 0$ and $3x - 4y - \frac{7}{2} = 0$ are two parallel tangents. Thus, distance between them is diameter of circle

$$\Rightarrow \text{Diameter} = \frac{\left| 4 + \frac{7}{2} \right|}{\sqrt{3^2 + 4^2}} = \frac{15}{2.5} = \frac{3}{2}$$

$$\text{and radius} = \frac{3}{4}$$

- 15.** Since, P lies on circle and A and B are points in plane such that, $\frac{PA}{PB} = k$, then the locus of P is perpendicular bisector of AB . Thus, the value of $k \neq 1$.

- 16.** Since, centre of circle is $(3, -1)$ which lies on $x + 3y = 0$

$$\Rightarrow x + 3y = 0 \text{ is diameter of } x^2 + y^2 - 6x + 2y = 0$$

Hence, given statement is true.

- 17.** Equations of any circle C with centre at $(0, \sqrt{2})$ is given by

$$(x-0)^2 + (y-\sqrt{2})^2 = r^2$$

$$\text{or } x^2 + y^2 - 2\sqrt{2}y + 2 = r^2 \quad \dots(\text{i})$$

where, $r > 0$.

Let $(x_1, y_1), (x_2, y_2), (x_3, y_3)$ be three distinct rational points on circle. Since, a straight line parallel to X -axis meets a circle in at most two points, either y_1, y_2 or y_1, y_3 .

On putting these in Eq. (i), we get

$$x_1^2 + y_1^2 - 2\sqrt{2}y_1 = r^2 - 2 \quad \dots(\text{ii})$$

$$x_2^2 + y_2^2 - 2\sqrt{2}y_2 = r^2 - 2 \quad \dots(\text{iii})$$

$$x_3^2 + y_3^2 - 2\sqrt{2}y_3 = r^2 - 2 \quad \dots(\text{iv})$$

On subtracting Eq. (ii) from Eq. (iii), we get

$$p_1 - \sqrt{2}q_1 = 0$$

$$\text{where, } p_1 = x_2^2 + y_2^2 - x_1^2 - y_1^2,$$

$$q_1 = y_2 - y_1$$

On subtracting Eq. (ii) from Eq. (iv), we get

$$p_2 - \sqrt{2}q_2 = 0$$

$$\text{where } p_2 = x_3^2 + y_3^2 - x_1^2 - y_1^2, q_2 = y_3 - y_1$$

Now, p_1, p_2, q_1, q_2 are rational numbers. Also, either $q_1 \neq 0$ or $q_2 \neq 0$. If $q_1 \neq 0$, then $\sqrt{2} = p_1/q_1$ and if $q_2 \neq 0$, then $\sqrt{2} = p_2/q_2$. In any case $\sqrt{2}$ is a rational number. This is a contradiction.

- 18.** The given circle is $ax^2 + 2hxy + by^2 = 1$... (i)

Let the point P not lying on Eq. (i) be (x_1, y_1) , let θ be the inclination of line through P which intersects the given curve at Q and R .

Then, equation of line through P is

$$\frac{x - x_1}{\cos \theta} = \frac{y - y_1}{\sin \theta} = r$$

$$\Rightarrow x = x_1 + r \cos \theta, y = y_1 + r \sin \theta$$

For points Q and R , above point must lie on Eq. (i).

$$\Rightarrow a(x_1 + r \cos \theta)^2 + 2h(x_1 + r \cos \theta)(y_1 + r \sin \theta) + b(y_1 + r \sin \theta)^2 = 1$$

$$\Rightarrow (a \cos^2 \theta + 2h \sin \theta \cos \theta + b \sin^2 \theta)r^2$$

$$+ 2(ax_1 \cos \theta + hx_1 \sin \theta + hy_1 \cos \theta + by_1 \sin \theta)r + (ax_1^2 + 2hx_1y_1 + by_1^2 - 1) = 0$$

It is quadratic in r , giving two values of r as PQ and PR .

$$\therefore PQ \cdot PR = \frac{ax_1^2 + 2hx_1y_1 + by_1^2 - 1}{a \cos^2 \theta + 2h \sin \theta \cos \theta + b \sin^2 \theta}$$

Here, $ax_1^2 + 2hx_1y_1 + by_1^2 - 1 \neq 0$, as (x_1, y_1) does not lie on Eq. (i),

Also, $a \cos^2 \theta + 2h \sin \theta \cos \theta + b \sin^2 \theta$

$$= a + 2h \sin \theta \cos \theta + (b - a) \sin^2 \theta$$

$$= a + \sin \theta \{2h \cos \theta + (b - a) \sin \theta\}$$

$$= a + \sin \theta \cdot \sqrt{4h^2 + (b - a)^2} \cdot (\cos \theta \sin \phi + \sin \theta \cos \phi)$$

$$\text{where, } \tan \theta = \frac{b - a}{2h}$$

$$= a + \sqrt{4h^2 + (b - a)^2} \sin \theta \sin(\theta + \phi)$$

which will be independent of θ , if

$$4h^2 + (b - a)^2 = 0$$

$$\Rightarrow h = 0 \text{ and } b = a$$

$$\therefore \text{Eq. (i) reduces to } x^2 + y^2 = \frac{1}{a}$$

which is a equation of circle.

- 19.** Let the radius of the circle be r . Take X -axis along AC and the $O(0, 0)$ as centre of the circle. Therefore, coordinate of A and C are $(-r, 0)$ and $(r, 0)$, respectively.

Now, $\angle BAC = \beta, \angle BOC = 2\beta$

Therefore, coordinates of B are $(r \cos 2\beta, r \sin 2\beta)$.

And slope of AD is $\tan(\beta - \alpha)$.

Let (x, y) be the coordinates of the point D . Equation of AD is

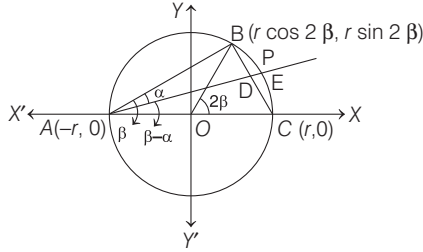

$$y = \tan(\beta - \alpha)(x + r) \quad \dots(i)$$

[∵ slope = $\tan(\beta - \alpha)$ and point is $(-r, 0)$]

Now, equation of BC is

$$y = \frac{r \sin 2\beta - 0}{r \cos 2\beta - r}(x - r)$$

$$\Rightarrow y = \frac{r \cdot 2 \sin \beta \cos \beta}{r(-2 \sin^2 \beta)}(x - r)$$

$$\Rightarrow y = \frac{2 \sin \beta \cos \beta}{-2 \sin^2 \beta}(x - r)$$

$$\Rightarrow y = -\cot \beta(x - r) \quad \dots(ii)$$

To obtain the coordinate of D , solve Eqs. (i) and (ii) simultaneously

$$\Rightarrow \tan(\beta - \alpha)(x + r) = -\cot \beta(x - r)$$

$$\Rightarrow x \tan(\beta - \alpha) + r \tan(\beta - \alpha) = -x \cot \beta + r \cot \beta$$

$$\Rightarrow x[\tan(\beta - \alpha) + \cot \beta] = r[\cot \beta - \tan(\beta - \alpha)]$$

$$\Rightarrow x \left[\frac{\sin(\beta - \alpha)}{\cos(\beta - \alpha)} + \frac{\cos \beta}{\sin \beta} \right] = r \left[\frac{\cos \beta}{\sin \beta} - \frac{\sin(\beta - \alpha)}{\cos(\beta - \alpha)} \right]$$

$$\Rightarrow x \left[\frac{\sin(\beta - \alpha) \sin \beta + \cos(\beta - \alpha) \cos \beta}{\cos(\beta - \alpha) \sin \beta} \right]$$

$$= r \left[\frac{\cos \beta \cos(\beta - \alpha) - \sin \beta \sin(\beta - \alpha)}{\sin \beta \cos(\beta - \alpha)} \right]$$

$$\Rightarrow x[\cos(\beta - \alpha - \beta)] = r[\cos(\beta - \alpha + \beta)]$$

$$\Rightarrow x = \frac{r \cos(2\beta - \alpha)}{\cos \alpha}$$

On putting this value in Eq. (ii), we get

$$y = -\cot \beta \left[\frac{r \cos(2\beta - \alpha)}{\cos \alpha} - r \right]$$

$$\Rightarrow y = -\frac{\cos \beta \cdot r}{\sin \beta} \left[\frac{\cos(2\beta - \alpha) - \cos \alpha}{\cos \alpha} \right]$$

$$\Rightarrow y = -\frac{r \cos \beta}{\sin \beta} \left[\frac{2 \sin \left(\frac{2\beta - \alpha + \alpha}{2} \right) \sin \left(\frac{\alpha - 2\beta + \alpha}{2} \right)}{\cos \alpha} \right]$$

$$\Rightarrow y = -\frac{r \cos \beta}{\sin \beta} \left[\frac{2 \sin \beta \cdot \sin(\alpha - \beta)}{\cos \alpha} \right]$$

$$= -2r \cos \beta \sin(\alpha - \beta) / \cos \alpha$$

Therefore, coordinates of D are

$$\left(\frac{r \cos(2\beta - \alpha)}{\cos \alpha}, -\frac{2r \cos \beta \sin(\alpha - \beta)}{\cos \alpha} \right)$$

Thus, coordinates of E are

$$\left(\frac{r \cos(2\beta - \alpha) + r \cos \alpha}{2 \cos \alpha}, -r \frac{\cos \beta \sin(\alpha - \beta)}{\cos \alpha} \right)$$

$$\Rightarrow r \frac{2 \cos \left(\frac{2\beta - \alpha + \alpha}{2} \right) \cdot \cos \left(\frac{2\beta - \alpha - \alpha}{2} \right)}{2 \cos \alpha},$$

$$r \frac{\cos \beta \sin(\beta - \alpha)}{\cos \alpha}$$

$$\Rightarrow r \frac{\cos \beta \cdot \cos(\beta - \alpha)}{\cos \alpha}, r \frac{\cos \beta \sin(\beta - \alpha)}{\cos \alpha}$$

Since, $AE = d$, we get

$$d^2 = r^2 \left[\frac{\cos \beta \cos(\beta - \alpha)}{\cos \alpha} + 1 \right]^2 + r^2 \left[\frac{\cos \beta \sin(\beta - \alpha)}{\cos \alpha} \right]^2$$

$$= \frac{r^2}{\cos^2 \alpha} [\cos^2 \beta \cos^2(\beta - \alpha) + \cos^2 \alpha$$

$$+ 2 \cos \beta \cos(\beta - \alpha) \cos \alpha + \cos^2 \beta \sin^2(\beta - \alpha)]$$

$$= \frac{r^2}{\cos^2 \alpha} [\cos^2 \beta \{\cos^2(\beta - \alpha) + \sin^2(\beta - \alpha)\} + \cos^2 \alpha$$

$$+ 2 \cos \beta \cos \alpha \cos(\beta - \alpha)]$$

$$= \frac{r^2}{\cos^2 \alpha} [\cos^2 \beta + \cos^2 \alpha + 2 \cos \alpha \cos \beta \cos(\beta - \alpha)]$$

$$\Rightarrow r^2 = \frac{d^2 \cos^2 \alpha}{\cos^2 \beta + \cos^2 \alpha + 2 \cos \alpha \cos \beta \cos(\beta - \alpha)}$$

Therefore, area of the circle

$$\pi r^2 = \frac{\pi d^2 \cos^2 \alpha}{\cos^2 \beta + \cos^2 \alpha + 2 \cos \alpha \cos \beta \cos(\beta - \alpha)}$$

20. Let the points $\left(m_i, \frac{1}{m_i}\right); i = 1, 2, 3, 4$

lie on a circle $x^2 + y^2 + 2gx + 2fy + c = 0$.

Then, $m_i^2 + \frac{1}{m_i^2} + 2gm_i + \frac{2f}{m_i} + c = 0$;

Since, $m_i^4 + 2gm_i^3 + cm_i^2 + 2fm_i + 1 = 0; i = 1, 2, 3, 4$

$\Rightarrow m_1, m_2, m_3$ and m_4 are the roots of the equation

$$m^4 + 2gm^3 + cm^2 + 2fm + 1 = 0$$

$$\Rightarrow m_1 m_2 m_3 m_4 = \frac{1}{1} = 1$$

21. Let (x_1, y_1) and (x_2, y_2) be the coordinates of points A and B , respectively.

It is given that x_1, x_2 are the roots of $x^2 + 2ax - b^2 = 0$

$$\Rightarrow x_1 + x_2 = -2a \text{ and } x_1 x_2 = -b^2 \quad \dots(i)$$

Also, y_1 and y_2 are the roots of $y^2 + 2py - q^2 = 0$

$$\Rightarrow y_1 + y_2 = -2p \text{ and } y_1 y_2 = -q^2 \quad \dots(ii)$$

∴ The equation of circle with AB as diameter is,

$$(x - x_1)(x - x_2) + (y - y_1)(y - y_2) = 0$$

$$\Rightarrow x^2 + y^2 - (x_1 + x_2)x - (y_1 + y_2)y + (x_1 x_2 + y_1 y_2) = 0$$

$$\Rightarrow x^2 + y^2 + 2ax + 2py - (b^2 + q^2) = 0$$

and radius = $\sqrt{a^2 + p^2 + b^2 + q^2}$

418 Circle

22. The circle and coordinate axes can have 3 common points, if it passes through origin. [$p=0$]

If circle is cutting one axis and touching other axis.

Only possibility is of touching X-axis and cutting

Y-axis. [$p=-1$]

23. $x^2 + y^2 \leq 6$ and $2x - 3y = 1$ is shown as

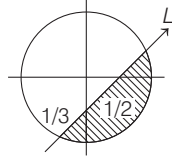

For the point to lie in the shade part, origin and the point lie on opposite side of straight line L .

\therefore For any point in shaded part $L > 0$ and for any point inside the circle $S < 0$.

Now, for $\left(2, \frac{3}{4}\right)$ $L: 2x - 3y - 1$

$$L: 4 - \frac{9}{4} - 1 = \frac{3}{4} > 0$$

and $S: x^2 + y^2 - 6, S: 4 + \frac{9}{16} - 6 < 0$

$\Rightarrow \left(2, \frac{3}{4}\right)$ lies in shaded part.

For $\left(\frac{5}{2}, \frac{3}{4}\right), L: 5 - 9 - 1 < 0$

[neglect]

For $\left(\frac{1}{4}, -\frac{1}{4}\right), L: \frac{1}{2} + \frac{3}{4} - 1 > 0$

$\therefore \left(\frac{1}{4}, -\frac{1}{4}\right)$ lies in the shaded part.

For $\left(\frac{1}{8}, \frac{1}{4}\right), L: \frac{1}{4} - \frac{3}{4} - 1 < 0$

[neglect]

\Rightarrow Only 2 points lie in the shaded part.

- 24.

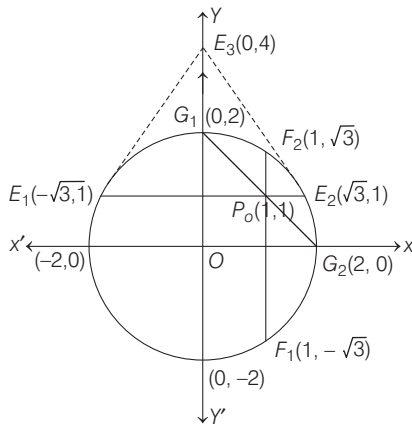

Equation of tangent at $E_1(-\sqrt{3}, 1)$ is

$-\sqrt{3}x + y = 4$ and at $E_2(\sqrt{3}, 1)$ is

$$\sqrt{3}x + y = 4$$

Intersection point of tangent at E_1 and E_2 is $(0, 4)$.

\therefore Coordinates of E_3 is $(0, 4)$

Similarly, equation of tangent at $F_1(1, -\sqrt{3})$ and $F_2(1, \sqrt{3})$ are $x - \sqrt{3}y = 4$ and $x + \sqrt{3}y = 4$, respectively and intersection point is $(4, 0)$, i.e., $F_3(4, 0)$ and equation of tangent at $G_1(0, 2)$ and $G_2(2, 0)$ are $2y = 4$ and $2x = 4$, respectively and intersection point is $(2, 2)$ i.e., $G_3(2, 2)$.

Point $E_3(0, 4), F_3(4, 0)$ and $G_3(2, 2)$ satisfies the line $x + y = 4$.

25. We have,

$$x^2 + y^2 = 4$$

Let $P(2 \cos \theta, 2 \sin \theta)$ be a point on a circle.

\therefore Tangent at P is

$$2 \cos \theta x + 2 \sin \theta y = 4$$

$$\Rightarrow x \cos \theta + y \sin \theta = 2$$

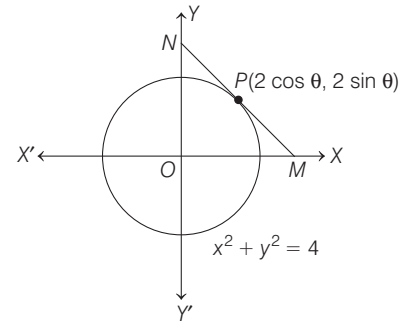

\therefore The coordinates at $M\left(\frac{2}{\cos \theta}, 0\right)$ and $N\left(0, \frac{2}{\sin \theta}\right)$

Let (h, k) is mid-point of MN

$$\therefore h = \frac{1}{\cos \theta} \quad \text{and} \quad k = \frac{1}{\sin \theta}$$

$$\Rightarrow \cos \theta = \frac{1}{h} \quad \text{and} \quad \sin \theta = \frac{1}{k}$$

$$\Rightarrow \cos^2 \theta + \sin^2 \theta = \frac{1}{h^2} + \frac{1}{k^2} \Rightarrow 1 = \frac{h^2 + k^2}{h^2 \cdot k^2}$$

$$\Rightarrow h^2 + k^2 = h^2 k^2$$

\therefore Mid-point of MN lie on the curve $x^2 + y^2 = x^2 y^2$

Topic 2 Relation between Two Circles

1. Equation of given circles

$$x^2 + y^2 + 5Kx + 2y + K = 0 \quad \dots(i)$$

and $2(x^2 + y^2) + 2Kx + 3y - 1 = 0$

$$\Rightarrow x^2 + y^2 + Kx + \frac{3}{2}y - \frac{1}{2} = 0 \quad \dots(ii)$$

On subtracting Eq. (ii) from Eq. (i), we get

$$4Kx + \frac{1}{2}y + K + \frac{1}{2} = 0$$

$$\Rightarrow 8Kx + y + (2K + 1) = 0 \quad \dots(iii)$$

[\because if $S_1 = 0$ and $S_2 = 0$ be two circles, then their common chord is given by $S_1 - S_2 = 0$.]

Eq. (iii) represents equation of common chord as it is given that circles (i) and (ii) intersects each other at points P and Q .

Since, line $4x + 5y - K = 0$ passes through point P and Q .

$$\therefore \frac{8K}{4} = \frac{1}{5} = \frac{2K+1}{-K}$$

$$\Rightarrow K = \frac{1}{10} \quad [\text{equating first and second terms}]$$

$$\text{and } -K = 10K + 5 \quad [\text{equating second and third terms}]$$

$$\Rightarrow 11K + 5 = 0 \Rightarrow K = -\frac{5}{11}$$

$\therefore \frac{1}{10} \neq -\frac{5}{11}$, so there is no such value of K , for which line $4x + 5y - K = 0$ passes through points P and Q .

2. Equation of given circle is $x^2 + y^2 = 1$, then equation of tangent at the point $(\cos \theta, \sin \theta)$ on the given circle is

$$x \cos \theta + y \sin \theta = 1 \quad \dots(i)$$

[\therefore Equation of tangent at the point $P(\cos \theta, \sin \theta)$ to the circle $x^2 + y^2 = r^2$ is $x \cos \theta + y \sin \theta = r$]

Now, the point of intersection with coordinate axes are $P(\sec \theta, 0)$ and $Q(0, \csc \theta)$.

\therefore Mid-point of line joining points P and Q is

$$M\left(\frac{\sec \theta}{2}, \frac{\csc \theta}{2}\right) = (h, k) \quad (\text{let})$$

$$\text{So, } \cos \theta = \frac{1}{2h} \text{ and } \sin \theta = \frac{1}{2k}$$

$$\therefore \sin^2 \theta + \cos^2 \theta = 1$$

$$\therefore \frac{1}{4h^2} + \frac{1}{4k^2} = 1 \Rightarrow \frac{1}{h^2} + \frac{1}{k^2} = 4$$

Now, locus of mid-point M is

$$\frac{1}{x^2} + \frac{1}{y^2} = 4$$

$$\Rightarrow x^2 + y^2 - 4x^2y^2 = 0$$

3. The given circles,

$$x^2 + y^2 - 2x - 2y + 1 = 0 \quad \dots (i)$$

$$\text{and } x^2 + y^2 - 18x - 2y + 78 = 0, \quad \dots (ii)$$

are on the opposite sides of the variable line $3x + 4y - \lambda = 0$. So, their centres also lie on the opposite sides of the variable line.

$$\Rightarrow [3(1) + 4(1) - \lambda] [3(9) + 4(1) - \lambda] < 0$$

[\therefore The points $P(x_1, y_1)$ and $Q(x_2, y_2)$ lie on the opposite sides of the line $ax + by + c = 0$, if $(ax_1 + by_1 + c)(ax_2 + by_2 + c) < 0$]

$$\Rightarrow (\lambda - 7)(\lambda - 31) < 0$$

$$\Rightarrow \lambda \in (7, 31) \quad \dots (iii)$$

$$\text{Also, we have } \left| \frac{3(1) + 4(1) - \lambda}{5} \right| \geq \sqrt{1+1-1}$$

[\therefore Distance of centre from the given line is greater than the radius, i.e. $\frac{ax_1 + by_1 + c}{\sqrt{a^2 + b^2}} \geq r$]

$$\Rightarrow |\lambda - 7| \geq 5 \Rightarrow \lambda \in (-\infty, 2] \cup [12, \infty) \quad \dots (iv)$$

$$\text{and } \left| \frac{3(9) + 4(1) - \lambda}{5} \right| \geq \sqrt{81 + 1 - 78}$$

$$\Rightarrow |\lambda - 31| \geq 10$$

$$\Rightarrow \lambda \in (-\infty, 21] \cup [41, \infty) \quad \dots (v)$$

From Eqs. (iii), (iv) and (v), we get

$$\lambda \in [12, 21]$$

4. Given circles,

$$x^2 + y^2 - 2x - 2y - 2 = 0 \quad \dots (i)$$

$$\text{and } x^2 + y^2 - 6x - 6y + 14 = 0 \quad \dots (ii)$$

are intersecting each other orthogonally, because

$$2(1)(3) + 2(1)(3) = 14 - 2$$

[\therefore two circles are intersected orthogonally if $2g_1g_2 + 2f_1f_2 = c_1 + c_2$]

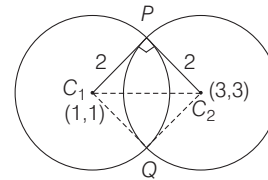

So, area of quadrilateral

$$PC_1QC_2 = 2 \times \text{ar}(\Delta PC_1C_2).$$

$$= 2 \times \left(\frac{1}{2} \times 2 \times 2 \right) = 4 \text{ sq units}$$

5. Circle I is $x^2 + y^2 - 16x - 20y + 164 = r^2$

$$\Rightarrow (x-8)^2 + (y-10)^2 = r^2$$

$\Rightarrow C_1(8, 10)$ is the centre of 1st circle and $r_1 = r$ is its radius

Circle II is $(x-4)^2 + (y-7)^2 = 36$

$\Rightarrow C_2(4, 7)$ is the centre of 2nd circle and $r_2 = 6$ is its radius.

Two circles intersect if $|r_1 - r_2| < C_1C_2 < r_1 + r_2$

$$\Rightarrow |r - 6| < \sqrt{(8-4)^2 + (10-7)^2} < r + 6$$

$$\Rightarrow |r - 6| < \sqrt{16+9} < r + 6$$

$$\Rightarrow |r - 6| < 5 < r + 6$$

Now as, $5 < r + 6$ always, we have to solve only

$$|r - 6| < 5 \Rightarrow -5 < r - 6 < 5$$

$$\Rightarrow 6 - 5 < r < 5 + 6 \Rightarrow 1 < r < 11$$

6. Given equation of a circle is $x^2 + y^2 - 4x + 6y - 12 = 0$, whose centre is $(2, -3)$ and radius

$$= \sqrt{2^2 + (-3)^2 + 12} = \sqrt{4+9+12} = 5$$

Now, according to given information, we have the following figure.

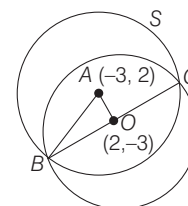

420 Circle

$$x^2 + y^2 - 4x + 6y - 12 = 0$$

Clearly, $AO \perp BC$, as O is mid-point of the chord.

Now, in $\triangle AOB$, we have

$$\begin{aligned} OA &= \sqrt{(-3-2)^2 + (2+3)^2} \\ &= \sqrt{25+25} = \sqrt{50} = 5\sqrt{2} \end{aligned}$$

and $OB = 5$

$$\begin{aligned} \therefore AB &= \sqrt{OA^2 + OB^2} \\ &= \sqrt{50 + 25} = \sqrt{75} = 5\sqrt{3} \end{aligned}$$

7. Here, radius of smaller circle, $AC = \sqrt{1^2 + 3^2} - 6 = 2$

Clearly, from the figure the radius of bigger circle

$$\begin{aligned} r^2 &= 2^2 + [(2-1)^2 + (1-3)^2] \\ r^2 &= 9 \Rightarrow r = 3 \end{aligned}$$

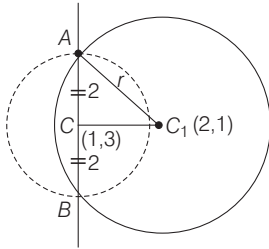

8. **PLAN** Number of common tangents depend on the position of the circle with respect to each other.

- If circles touch externally $\Rightarrow C_1C_2 = r_1 + r_2$, 3 common tangents.
- If circles touch internally $\Rightarrow C_1C_2 = r_2 - r_1$, 1 common tangent.
- If circles do not touch each other, 4 common tangents.

Given equations of circles are

$$x^2 + y^2 - 4x - 6y - 12 = 0 \quad \dots(i)$$

$$x^2 + y^2 + 6x + 18y + 26 = 0 \quad \dots(ii)$$

Centre of circle (i) is $C_1(2,3)$ and radius

$$= \sqrt{4+9+12} = 5(r_1) \quad [\text{say}]$$

Centre of circle (ii) is $C_2(-3,-9)$ and radius

$$= \sqrt{9+81-26} = 8(r_2) \quad [\text{say}]$$

$$\text{Now, } C_1C_2 = \sqrt{(2+3)^2 + (3+9)^2}$$

$$\Rightarrow C_1C_2 = \sqrt{5^2 + 12^2}$$

$$\Rightarrow C_1C_2 = \sqrt{25+144} = 13$$

$$\therefore r_1 + r_2 = 5 + 8 = 13$$

$$\text{Also, } C_1C_2 = r_1 + r_2$$

Thus, both circles touch each other externally. Hence, there are three common tangents.

9. **PLAN** Use the property, when two circles touch each other externally, then distance between the centre is equal to sum of their radii, to get required radius.

Let the coordinate of the centre of T be $(0, k)$.

Distance between their centre

$$k+1 = \sqrt{1+(k-1)^2} \quad [\because C_1C_2 = k+1]$$

$$\Rightarrow k+1 = \sqrt{1+k^2+1-2k}$$

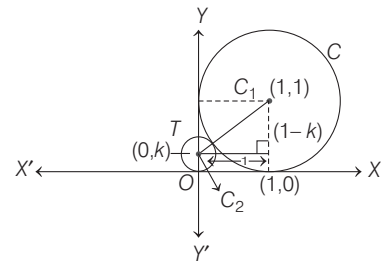

$$\Rightarrow k+1 = \sqrt{k^2+2-2k}$$

$$\Rightarrow k^2+1+2k = k^2+2-2k$$

$$\Rightarrow k = \frac{1}{4}$$

So, the radius of circle T is k , i.e. $\frac{1}{4}$.

10. Since, the given circles intersect orthogonally.

$$\therefore 2(1)(0) + 2(k)(k) = 6 + k$$

$$[\because 2g_1g_2 + 2f_1f_2 = c_1 + c_2]$$

$$\Rightarrow 2k^2 - k - 6 = 0 \Rightarrow k = -\frac{3}{2}, 2$$

11. Let O is the point at centre and P is the point at circumference. Therefore, angle QOR is double the angle QPR . So, it is sufficient to find the angle QOR .

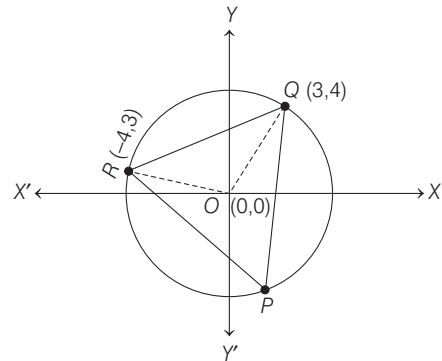

Now, slope of $OQ, m_1 = 4/3$,
slope of $OR, m_2 = -3/4$

Here, $m_1 m_2 = -1$

Therefore, $\angle QOR = \pi/2$

which implies that $\angle QPR = \pi/4$

12. Given, $x^2 + y^2 = 4$

Centre $\equiv C_1 \equiv (0,0)$ and $R_1 = 2$

Again, $x^2 + y^2 - 6x - 8y - 24 = 0$, then $C_2 \equiv (3,4)$

and $R_2 = 7$

Again, $C_1C_2 = 5 = R_2 - R_1$

Therefore, the given circles touch internally such that, they can have just one common tangent at the point of contact.

13. Centre of the circle

$$x^2 + y^2 + 4x - 6y + 9 \sin^2 \alpha + 13 \cos^2 \alpha = 0$$

is $C(-2, 3)$ and its radius is

$$\begin{aligned} & \sqrt{(-2)^2 + (3)^2 - 9\sin^2\alpha - 13\cos^2\alpha} \\ &= \sqrt{13 - 13\cos^2\alpha - 9\sin^2\alpha} \\ &= \sqrt{13\sin^2\alpha - 9\sin^2\alpha} = \sqrt{4\sin^2\alpha} = 2\sin\alpha \end{aligned}$$

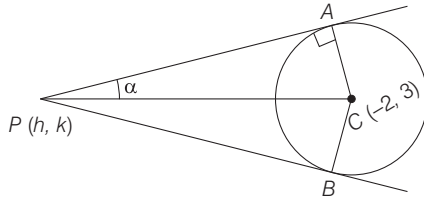

Let (h, k) be any point P and

$$\angle APC = \alpha, \angle PAC = \pi/2$$

That is, triangle APC is a right angled triangle.

$$\therefore \sin\alpha = \frac{AC}{PC} = \frac{2\sin\alpha}{\sqrt{(h+2)^2 + (k-3)^2}}$$

$$\begin{aligned} \Rightarrow & (h+2)^2 + (k-3)^2 = 4 \\ \Rightarrow & h^2 + 4 + 4h + k^2 + 9 - 6k = 4 \\ \Rightarrow & h^2 + k^2 + 4h - 6k + 9 = 0 \end{aligned}$$

Thus, required equation of the locus is $x^2 + y^2 + 4x - 6y + 9 = 0$

14. As, the two circles intersect in two distinct points.

\Rightarrow Distance between centres lies between $|r_1 - r_2|$ and $|r_1 + r_2|$.

$$\text{i.e. } |r - 3| < \sqrt{(4-1)^2 + (-1-3)^2} < |r + 3|$$

$$\Rightarrow |r - 3| < 5 < |r + 3| \Rightarrow r < 8 \text{ or } r > 2$$

$$\therefore 2 < r < 8$$

15. Let $x^2 + y^2 + 2gx + 2fy + c = 0$, cuts $x^2 + y^2 = k^2$ orthogonally.

$$\begin{aligned} \Rightarrow & 2g_1g_2 + 2f_1f_2 = c_1 + c_2 \\ \Rightarrow & -2g \cdot 0 - 2f \cdot 0 = c - k^2 \\ \Rightarrow & c = k^2 \end{aligned} \quad \dots(\text{i})$$

Also, $x^2 + y^2 + 2gx + 2fy + k^2 = 0$ passes through (a, b) .

$$\therefore a^2 + b^2 + 2ga + 2fb + k^2 = 0 \quad \dots(\text{ii})$$

\Rightarrow Required equation of locus of centre is

$$-2ax - 2by + a^2 + b^2 + k^2 = 0$$

$$\text{or } 2ax + 2by - (a^2 + b^2 + k^2) = 0$$

16. It is given that T is tangents to S_1 at P and S_2 at Q and S_1 and S_2 touch externally at M .

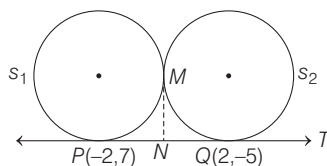

$$\therefore MN = NP = NQ$$

\therefore Locus of M is a circle having PQ as its diameter of circle.

\therefore Equation of circle

$$(x - 2)(x + 2) + (y + 5)(y - 7) = 0$$

$$\Rightarrow x^2 + y^2 - 2y - 39 = 0$$

$$\text{Hence, } E_1 : x^2 + y^2 - 2y - 39 = 0, x \neq \pm 2$$

Locus of mid-point of chord (h, k) of the circle E_1 is

$$xh + yk - (y + k) - 39 = h^2 + k^2 - 2k - 39$$

$$\Rightarrow xh + yk - y - k = h^2 + k^2 - 2k$$

Since, chord is passing through $(1, 1)$.

\therefore Locus of mid-point of chord (h, k) is

$$h + k - 1 - k = h^2 + k^2 - 2k$$

$$\Rightarrow h^2 + k^2 - 2k - h + 1 = 0$$

Locus is $E_2 : x^2 + y^2 - x - 2y + 1 = 0$

Now, after checking options, (a) and (d) are correct.

17. PLAN

(i) The general equation of a circle is

$$x^2 + y^2 + 2gx + 2fy + c = 0$$

where, centre and radius are given by $(-g, -f)$ and $\sqrt{g^2 + f^2 - c}$, respectively.

(ii) If the two circles $x^2 + y^2 + 2g_1x + 2f_1y + c_1 = 0$ and $x^2 + y^2 + 2g_2x + 2f_2y + c_2 = 0$ are orthogonal, then $2g_1g_2 + 2f_1f_2 = c_1 + c_2$.

Let circle be $x^2 + y^2 + 2gx + 2fy + c = 0$

It passes through $(0, 1)$.

$$\therefore 1 + 2f + c = 0 \quad \dots(\text{i})$$

Orthogonal with $x^2 + y^2 - 2x - 15 = 0$

$$2g(-1) = c - 15$$

$$\Rightarrow c = 15 - 2g \quad \dots(\text{ii})$$

Orthogonal with $x^2 + y^2 - 1 = 0$

$$c = 1$$

$$\dots(\text{iii})$$

$$\Rightarrow g = 7 \text{ and } f = -1$$

Centre is $(-g, -f) \equiv (-7, 1)$

$$\begin{aligned} \therefore \text{Radius} &= \sqrt{g^2 + f^2 - c} \\ &= \sqrt{49 + 1 - 1} = 7 \end{aligned}$$

18. Let the, equation of circles are

$$C_1 : (x-1)^2 + (y-1)^2 = (1)^2$$

$$\text{and } C_2 : (x-1)^2 + (y-1)^2 = (\sqrt{2})^2$$

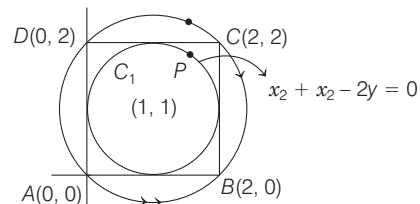

\therefore Coordinates of $P(1 + \cos\theta, 1 + \sin\theta)$

and $Q(1 + \sqrt{2}\cos\theta, 1 + \sqrt{2}\sin\theta)$

$$\therefore PA^2 + PB^2 + PC^2 + PD^2$$

422 Circle

$$= \{(1 + \cos \theta)^2 + (1 + \sin \theta)^2\} + \{(\cos \theta - 1)^2 + (1 + \sin \theta)^2\} \\ + \{(\cos \theta - 1)^2 + (\sin \theta - 1)^2\} \\ + \{(1 + \cos \theta)^2 + (\sin \theta - 1)^2\} = 12$$

Similarly, $QA^2 + QB^2 + QC^2 + QD^2 = 16$

$$\therefore \frac{\Sigma PA^2}{\Sigma QA^2} = \frac{12}{16} = 0.75$$

19. Let C be the centre of the required circle.

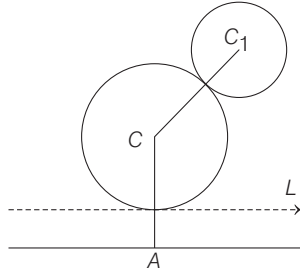

Now, draw a line parallel to L at a distance of r_1 (radius of C_1) from it.

Now, $CC_1 = AC \Rightarrow C$ lies on a parabola.

20. Since, $AG = \sqrt{2}$
 $\therefore AT_1 = T_1G = \frac{1}{\sqrt{2}}$

As, A is the focus, T_1 is the vertex and BD is the directrix of parabola.

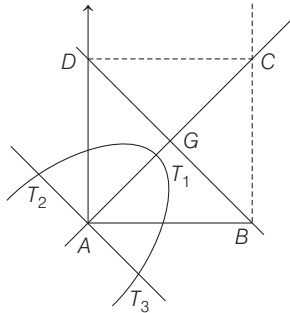

Also, T_2T_3 is latusrectum.

$$\therefore T_2T_3 = 4 \cdot \frac{1}{\sqrt{2}}$$

$$\therefore \text{Area of } \Delta T_1T_2T_3 = \frac{1}{2} \times \frac{1}{\sqrt{2}} \times \frac{4}{\sqrt{2}} = 1 \text{ sq unit}$$

21. (A) When two circles are intersecting they have a common normal and common tangent.
 (B) Two mutually external circles have a common normal and common tangent.
 (C) When one circle lies inside of other, then they have a common normal but no common tangent.
 (D) Two branches of a hyperbola have a common normal but no common tangent.
22. Let the given circles C_1 and C_2 have centres O_1 and O_2 and radii r_1 and r_2 , respectively.

Let the variable circle C touching C_1 internally, C_2 externally have a radius r and centre at O .

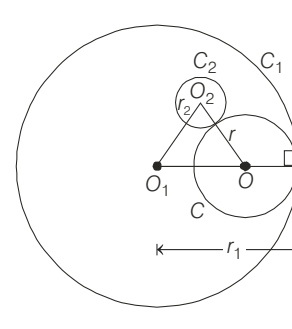

Now, $OO_2 = r + r_2$
 and $OO_1 = r_1 - r$
 $\Rightarrow OO_1 + OO_2 = r_1 + r_2$
 which is greater than O_1O_2 as $O_1O_2 < r_1 + r_2$
 $[\because C_2 \text{ lies inside } C_1]$
 \Rightarrow Locus of O is an ellipse with foci O_1 and O_2 .

Alternate Solution

Let equations of C_1 be $x^2 + y^2 = r_1^2$ and of C_2 be $(x - a)^2 + (y - b)^2 = r_2^2$

Let centre C be (h, k) and radius r , then by the given condition

$$\sqrt{(h - a)^2 + (k - b)^2} = r + r_2 \text{ and } \sqrt{h^2 + k^2} = r_1 - r$$

$$\Rightarrow \sqrt{(h - a)^2 + (k - b)^2} + \sqrt{h^2 + k^2} = r_1 + r_2$$

Required locus is

$$\sqrt{(x - a)^2 + (y - b)^2} + \sqrt{x^2 + y^2} = r_1 + r_2$$

which represents an ellipse whose foci are (a, b) and $(0, 0)$.

23. Suppose the circles have centres at C_1, C_2 and C_3 with radius R_1, R_2 and R_3 , respectively. Let the circles touch at A, B and C . Let the common tangents at A, B and C meet at O . We have, $OA = OB = OC = 4$ [given]. Now, the circle with centre at O and passing through A, B and C is the incircle of the triangle $C_1C_2C_3$ (because $OA \perp C_1C_2$).

Therefore, the inradius of $\Delta C_1C_2C_3$ is 4.

and $r = \frac{\Delta}{s} \dots(i)$

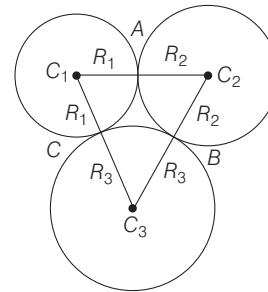

Now, perimeter of a triangle

$$2s = R_1 + R_2 + R_2 + R_3 + R_3 + R_1$$

$$\Rightarrow 2s = 2(R_1 + R_2 + R_3)$$

$$\Rightarrow s = R_1 + R_2 + R_3$$

and $\Delta = \sqrt{s(s-a)(s-b)(s-c)}$
 $= \sqrt{(R_1 + R_2 + R_3)(R_3)(R_2)(R_1)}$
 From Eq. (i), $4 = \frac{\sqrt{R_1 R_2 R_3 (R_1 + R_2 + R_3)}}{R_1 + R_2 + R_3}$
 $\Rightarrow 16 = \frac{R_1 R_2 R_3 (R_1 + R_2 + R_3)}{(R_1 + R_2 + R_3)^2}$
 $\Rightarrow 16 = \frac{R_1 R_2 R_3}{R_1 + R_2 + R_3}$

Topic 3 Equation of Tangent, Normal and Length of Tangents

1. Since, equation of a circle which touches the Y-axis at point (0, 4) is

$$x^2 + (y - 4)^2 + \lambda x = 0 \quad \dots (i)$$

\therefore Circle (i) passes through point (2, 0), so

$$4 + 16 + 2\lambda = 0$$

$$\Rightarrow \lambda = -10$$

Therefore, equation of the circle is

$$x^2 + (y - 4)^2 - 10x = 0$$

$$\Rightarrow (x - 5)^2 + (y - 4)^2 = 25 \quad \dots (ii)$$

Now, equation of tangent to the circle (ii) having slope 'm' is

$$y - 4 = m(x - 5) \pm 5\sqrt{1 + m^2}$$

$$\Rightarrow y = mx + (4 - 5m \pm 5\sqrt{1 + m^2}) \quad \dots (iii)$$

From the option, on taking slope of line, we have

when $m = \frac{4}{3}$, equation of tangent by Eq. (iii), we get

$$y = \frac{4}{3}x + \left(4 - \frac{20}{3} \pm 5\sqrt{1 + \frac{16}{9}}\right)$$

$$\Rightarrow 3y = 4x + (12 - 20 \pm 25)$$

$$\Rightarrow 4x - 3y - 8 \pm 25 = 0$$

$$\Rightarrow 4x - 3y + 17 = 0 \text{ and } 4x - 3y - 33 = 0$$

Similarly, when $m = -3/4$, equation of tangent is

$$y = -\frac{3}{4}x + \left(4 + \frac{15}{4} \pm 5\sqrt{1 + \frac{9}{16}}\right)$$

$$\Rightarrow 4y = -3x + 31 \pm 25$$

$$\Rightarrow 3x + 4y - 56 = 0 \text{ and } 3x + 4y - 6 = 0$$

Similarly, when $m = -\frac{4}{3}$, equation of tangent is

$$y = -\frac{4}{3}x + \left(4 + \frac{20}{3} \pm \frac{25}{3}\right)$$

$$\Rightarrow 4x + 3y - 57 = 0 \text{ and } 4x + 3y - 7 = 0$$

\therefore The line $4x + 3y - 8 = 0$ is not a tangent to the circle.

Hence, option (c) is correct.

2. Given circles are $x^2 + y^2 = 4$, centre $c_1(0, 0)$ and radius $r_1 = 2$

and $x^2 + y^2 + 6x + 8y - 24 = 0$, centre $c_2(-3, -4)$ and radius $r_2 = 7$

$$\therefore c_1 c_2 = \sqrt{9 + 16} = 5$$

$$\text{and } |r_1 - r_2| = 5$$

$$\therefore c_1 c_2 = |r_1 - r_2| = 5$$

\therefore circle $x^2 + y^2 = 4$ touches the circle $x^2 + y^2 + 6x + 8y - 24 = 0$ internally.

So, equation of common tangent is

$$S_1 - S_2 = 0$$

$$\Rightarrow 6x + 8y - 20 = 0$$

$$\Rightarrow 3x + 4y = 10 \quad \dots (i)$$

The common tangent passes through the point (6, -2), from the given options.

3. Given points are (-8, 5) and (6, 5) in which y-coordinate is same, i.e. these points lie on horizontal line $y = 5$.

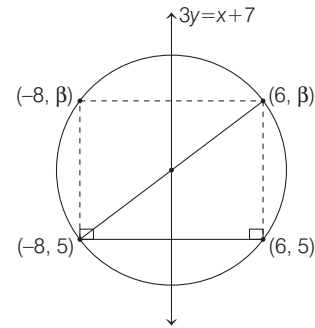

Let (-8, β) and (6, β) are the coordinates of the other vertices of rectangle as shown in the figure.

Since, the mid-point of line joining points (-8, 5) and (6, β) lies on the line $3y = x + 7$.

$$\therefore 3\left(\frac{5 + \beta}{2}\right) = \frac{-8 + 6}{2} + 7$$

$$\Rightarrow 15 + 3\beta = -2 + 14$$

$$\Rightarrow 3\beta = -3$$

$$\Rightarrow \beta = -1$$

$$\text{Now, area of rectangle} = |-8 - 6| \times |\beta - 5| = 14 \times 6 = 84$$

4. Let $T = 0$ and $N = 0$ represents the tangent and normal lines at the point $P(\sqrt{3}, 1)$ to the circle $x^2 + y^2 = 4$.

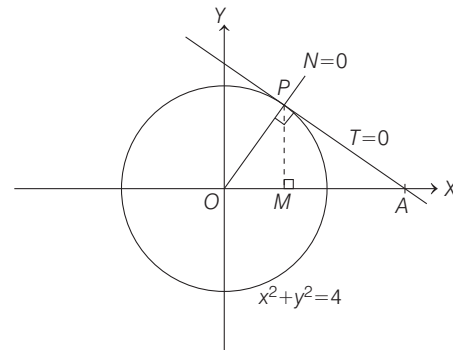

So, equation of tangent ($T = 0$) is

$$\sqrt{3}x + y = 4 \quad \dots (i)$$

424 Circle

For point A, put $y=0$, we get

$$x = \frac{4}{\sqrt{3}}$$

$$\therefore \text{Area of required } \triangle OPA = \frac{1}{2} (OA)(PM) = \frac{1}{2} \times \frac{4}{\sqrt{3}} \times 1$$

$$\begin{aligned} & [\because PM = y\text{-coordinate of } P] \\ & = \frac{2}{\sqrt{3}} \text{ sq unit} \end{aligned}$$

5. According to given information, we have the following figure.

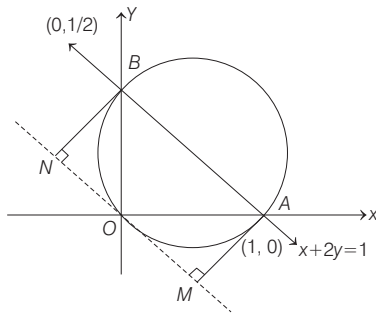

From figure, equation of circle (diameter form) is

$$(x-1)(x-0) + (y-0)\left(y-\frac{1}{2}\right) = 0$$

$$\Rightarrow x^2 + y^2 - x - \frac{y}{2} = 0$$

Equation of tangent at $(0, 0)$ is $x + \frac{y}{2} = 0$

[\because equation of tangent at (x_1, y_1) is given by $T=0$.

Here, $T=0$

$$\Rightarrow xx_1 + yy_1 - \frac{1}{2}(x+x_1) - \frac{1}{4}(y+y_1) = 0] \Rightarrow 2x + y = 0$$

$$\text{Now, } AM = \frac{|2 \cdot 1 + 1 \cdot 0|}{\sqrt{5}} = \frac{2}{\sqrt{5}}$$

[\because distance of a point $P(x_1, y_1)$ from a line

$$ax + by + c = 0 \text{ is } \frac{|ax_1 + by_1 + c|}{\sqrt{a^2 + b^2}}$$

$$\text{and } BN = \frac{\left|2 \cdot 0 + 1 \cdot \left(\frac{1}{2}\right)\right|}{\sqrt{5}} = \frac{1}{2\sqrt{5}}$$

$$\therefore AM + BN = \frac{2}{\sqrt{5}} + \frac{1}{2\sqrt{5}} = \frac{4+1}{2\sqrt{5}} = \frac{\sqrt{5}}{2}$$

6. Equation of tangent to the circle $x^2 + y^2 + 4x - 6y - 12 = 0$ at $(1, -1)$ is given by $xx_1 + yy_1 + 2(x+x_1) - 3(y+y_1) - 12 = 0$, where $x_1 = 1$ and $y_1 = -1$

$$\Rightarrow x - y + 2(x+1) - 3(y-1) - 12 = 0$$

$$\Rightarrow 3x - 4y - 7 = 0$$

This will also a tangent to the required circle.

Now, equation of family of circles touching the line $3x - 4y - 7 = 0$ at point $(1, -1)$ is given by

$$(x-1)^2 + (y+1)^2 + \lambda(3x-4y-7) = 0$$

So, the equation of required circle will be $(x-1)^2 + (y+1)^2 + \lambda(3x-4y-7) = 0$, for some $\lambda \in R$

...(i)

\therefore The required circle passes through $(4, 0)$

$$\therefore (4-1)^2 + (0+1)^2 + \lambda(3 \times 4 - 4 \times 0 - 7) = 0$$

$$\Rightarrow 9 + 1 + \lambda(5) = 0$$

$$\Rightarrow \lambda = -2$$

Substituting $\lambda = -2$ in Eq. (i), we get

$$(x-1)^2 + (y+1)^2 - 2(3x-4y-7) = 0$$

$$\Rightarrow x^2 + y^2 - 8x + 10y + 16 = 0$$

On comparing it with

$$x^2 + y^2 + 2gx + 2fy + c = 0, \text{ we get}$$

$$g = -4, f = 5, c = 16$$

$$\therefore \text{Radius} = \sqrt{g^2 + f^2 - c}$$

$$= \sqrt{16 + 25 - 16} = 5$$

7. **Key Idea** Equation of tangent to the curve

$$x^2 = 4ay \text{ at } (x_1, y_1) \text{ is } xx_1 = 4a\left(\frac{y+y_1}{2}\right)$$

Tangent to the curve $x^2 = y - 6$ at $(1, 7)$ is

$$x = \frac{y+7}{2} - 6$$

$$\Rightarrow 2x - y + 5 = 0$$

...(i)

Equation of circle is $x^2 + y^2 + 16x + 12y + c = 0$

Centre $(-8, -6)$

$$r = \sqrt{8^2 + 6^2 - c} = \sqrt{100 - c}$$

Since, line $2x - y + 5 = 0$ also touches the circle.

$$\therefore \sqrt{100 - c} = \frac{|2(-8) - (-6) + 5|}{\sqrt{2^2 + 1^2}}$$

$$\Rightarrow \sqrt{100 - c} = \frac{|-16 + 6 + 5|}{\sqrt{5}}$$

$$\Rightarrow \sqrt{100 - c} = |-\sqrt{5}|$$

$$\Rightarrow 100 - c = 5$$

$$\Rightarrow c = 95$$

8. $18 = \frac{1}{2}(3\alpha)(2r)$

$$\Rightarrow \alpha r = 6$$

Line, $y = -\frac{2r}{\alpha}(x-2\alpha)$ is tangent to circle

$$(x-r)^2 + (y-r)^2 = r^2$$

$$2\alpha = 3r, \alpha r = 6 \text{ and } r = 2$$

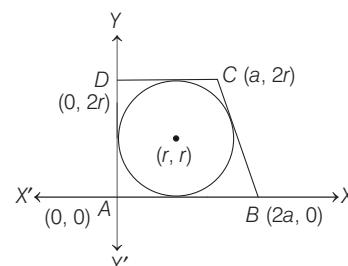

Alternate Solution

$$\frac{1}{2}(x+2x) \times 2r = 18$$

$$xr = 6 \quad \dots (i)$$

In ΔAOB , $\tan \theta = \frac{x-r}{r}$

and in ΔDOC ,

$$\tan(90^\circ - \theta) = \frac{2x-r}{r}$$

$$\therefore \frac{x-r}{r} = \frac{r}{2x-r}$$

$$\Rightarrow x(2x-3r) = 0$$

$$\Rightarrow x = \frac{3r}{2} \quad \dots (ii)$$

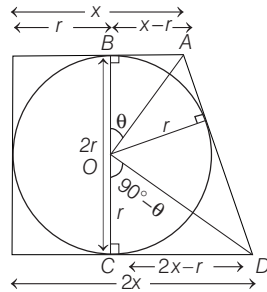

From Eqs. (i) and (ii), we get

$$r = 2$$

9. The line $5x - 2y + 6 = 0$ meets the Y -axis at the point $(0, 3)$ and therefore the tangent has to pass through the point $(0, 3)$ and required length

$$= \sqrt{x_1^2 + y_1^2 + 6x_1 + 6y_1 - 2}$$

$$= \sqrt{0^2 + 3^2 + 6(0) + 6(3) - 2} = \sqrt{25} = 5$$

10. From figure, it is clear that ΔPRQ and ΔRSP are similar.

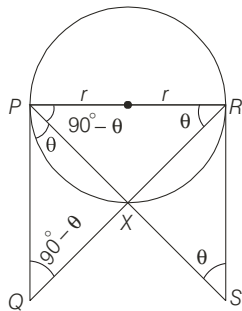

$$\therefore \frac{PR}{RS} = \frac{PQ}{RP} \Rightarrow PR^2 = PQ \cdot RS$$

$$\Rightarrow PR = \sqrt{PQ \cdot RS} \Rightarrow 2r = \sqrt{PQ \cdot RS}$$

11. Given, RS is the diameter of $x^2 + y^2 = 1$.

Here, equation of the tangent at $P(\cos \theta, \sin \theta)$ is $x \cos \theta + y \sin \theta = 1$.

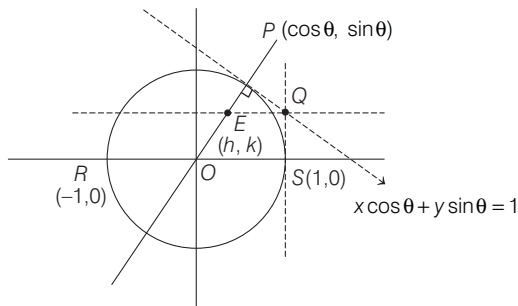

Intersecting with $x = 1$,

$$y = \frac{1 - \cos \theta}{\sin \theta}$$

$$\therefore Q\left(1, \frac{1 - \cos \theta}{\sin \theta}\right)$$

\therefore Equation of the line through Q parallel to RS is

$$y = \frac{1 - \cos \theta}{\sin \theta} = \frac{2 \sin^2 \frac{\theta}{2}}{2 \sin \frac{\theta}{2} \cos \frac{\theta}{2}} = \tan \frac{\theta}{2} \quad \dots (i)$$

Normal at $P : y = \frac{\sin \theta}{\cos \theta} \cdot x$

$$\Rightarrow y = x \tan \theta \quad \dots (ii)$$

Let their point of intersection be (h, k) .

Then, $k = \tan \frac{\theta}{2}$ and $k = h \tan \theta$

$$\therefore k = h \left(\frac{2 \tan \frac{\theta}{2}}{1 - \tan^2 \frac{\theta}{2}} \right) \Rightarrow k = \frac{2h \cdot k}{1 - k^2}$$

$$\Rightarrow k(1 - k^2) = 2hk$$

\therefore Locus for point $E : 2x = (1 - y^2) \quad \dots (iii)$

When $x = \frac{1}{3}$, then

$$1 - y^2 = \frac{2}{3} \Rightarrow y^2 = 1 - \frac{2}{3} \Rightarrow y = \pm \frac{1}{\sqrt{3}}$$

$\therefore \left(\frac{1}{3}, \pm \frac{1}{\sqrt{3}}\right)$ satisfy $2x = 1 - y^2$.

When $x = \frac{1}{4}$, then

$$1 - y^2 = \frac{2}{4} \Rightarrow y^2 = 1 - \frac{1}{2} \Rightarrow y = \pm \frac{1}{\sqrt{2}}$$

$\therefore \left(\frac{1}{4}, \pm \frac{1}{2}\right)$ does not satisfy $1 - y^2 = 2x$.

12. Given, $C_1 : x^2 + y^2 = 3$ intersects the parabola $x^2 = 2y$.

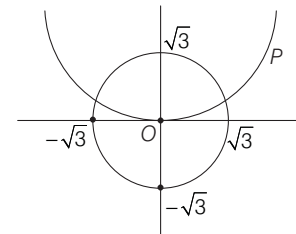

On solving $x^2 + y^2 = 3$ and $x^2 = 2y$, we get

$$\Rightarrow y^2 + 2y = 3$$

$$\Rightarrow y^2 + 2y - 3 = 0$$

$$\Rightarrow (y+3)(y-1) = 0$$

$$\therefore y = 1, -3 \text{ [neglecting } y = -3, \text{ as } -\sqrt{3} \leq y \leq \sqrt{3}]$$

$$\therefore y = 1 \Rightarrow x = \pm \sqrt{2}$$

$$\Rightarrow P(\sqrt{2}, 1) \in \text{I quadrant}$$

Equation of tangent at $P(\sqrt{2}, 1)$ to $C_1 : x^2 + y^2 = 3$ is

$$\sqrt{2}x + 1 \cdot y = 3 \quad \dots (i)$$

426 Circle

Now, let the centres of C_2 and C_3 be Q_2 and Q_3 , and tangent at P touches C_2 and C_3 at R_2 and R_3 shown as below

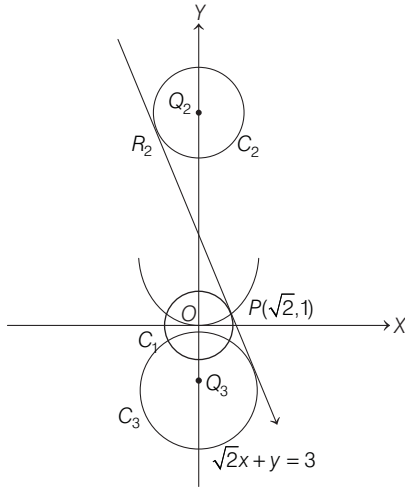

Let Q_2 be $(0, k)$ and radius is $2\sqrt{3}$.

$$\therefore \frac{|0 + k - 3|}{\sqrt{2 + 1}} = 2\sqrt{3}$$

$$\Rightarrow |k - 3| = 6$$

$$\Rightarrow k = 9, -3$$

$$\therefore Q_2(0, 9) \text{ and } Q_3(0, -3)$$

$$\text{Hence, } Q_2Q_3 = 12$$

\therefore Option (a) is correct.

Also, R_2R_3 is common internal tangent to C_2 and C_3 , and

$$\begin{aligned} r_2 = r_3 &= 2\sqrt{3} \\ \therefore R_2R_3 &= \sqrt{d^2 - (r_1 + r_2)^2} \\ &= \sqrt{12^2 - (4\sqrt{3})^2} \\ &= \sqrt{144 - 48} \\ &= \sqrt{96} = 4\sqrt{6} \end{aligned}$$

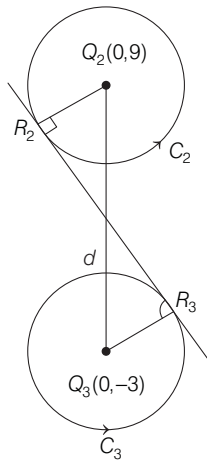

\therefore Option (b) is correct.

\therefore Length of perpendicular from $O(0, 0)$ to R_2R_3 is equal to radius of $C_1 = \sqrt{3}$.

$$\therefore \text{Area of } \triangle OR_2R_3 = \frac{1}{2} \times R_2R_3 \times \sqrt{3} = \frac{1}{2} \times 4\sqrt{6} \times \sqrt{3} = 6\sqrt{2}$$

\therefore Option (c) is correct.

$$\text{Also, area of } \triangle PQ_2Q_3 = \frac{1}{2} Q_2Q_3 \times \sqrt{2} = \frac{\sqrt{2}}{2} \times 12 = 6\sqrt{2}$$

\therefore Option (d) is incorrect.

13. As locus of point of intersection for perpendicular tangents is **directors circle**.

$$\text{i.e. } x^2 + y^2 = 2r^2$$

Here, $(17, 7)$ lie on directors circle $x^2 + y^2 = 338$

\Rightarrow Tangents are perpendicular.

14. Here, tangent to $x^2 + y^2 = 4$ at $(\sqrt{3}, 1)$ is $\sqrt{3}x + y = 4 \dots(i)$

As, L is perpendicular to $\sqrt{3}x + y = 4$

$\Rightarrow x - \sqrt{3}y = \lambda$ which is tangent to

$$(x - 3)^2 + y^2 = 1 \Rightarrow \frac{|3 - 0 - \lambda|}{\sqrt{1 + 3}} = 1$$

$$\Rightarrow |3 - \lambda| = 2 \Rightarrow 3 - \lambda = 2, -2$$

$$\therefore \lambda = 1, 5$$

$$\Rightarrow L : x - \sqrt{3}y = 1, x - \sqrt{3}y = 5$$

15. Here, equation of common tangent be

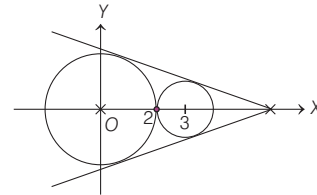

$$y = mx \pm 2\sqrt{1 + m^2}$$

which is also the tangent to

$$(x - 3)^2 + y^2 = 1$$

$$\Rightarrow \frac{|3m - 0 + 2\sqrt{1 + m^2}|}{\sqrt{m^2 + 1}} = 1$$

$$\Rightarrow 3m + 2\sqrt{1 + m^2} = \pm \sqrt{1 + m^2}$$

$$\Rightarrow 3m = -3\sqrt{1 + m^2}$$

$$\text{or } 3m = -\sqrt{1 + m^2}$$

$$\Rightarrow m^2 = 1 + m^2 \text{ or } 9m^2 = 1 + m^2$$

$$\Rightarrow m \in \phi \text{ or } m = \pm \frac{1}{2\sqrt{2}}$$

$$\therefore y = \pm \frac{1}{2\sqrt{2}}x \pm 2\sqrt{1 + \frac{1}{8}}$$

$$\Rightarrow y = \pm \frac{x}{2\sqrt{2}} \pm \frac{6}{2\sqrt{2}}$$

$$\Rightarrow 2\sqrt{2}y = \pm(x + 6)$$

$$\therefore x + 2\sqrt{2}y = 6$$

16. Let centre of circle C be (h, k) .

$$\text{Then, } \frac{|\sqrt{3}h + k - 6|}{\sqrt{3 + 1}} = 1$$

$$\Rightarrow \sqrt{3}h + k - 6 = 2, -2$$

$$\Rightarrow \sqrt{3}h + k = 4 \quad \dots(i)$$

[rejecting 2 because origin and centre of C are on the same side of PQ]

The point $(\sqrt{3}, 1)$ satisfies Eq. (i).
 \therefore Equation of circle C is $(x - \sqrt{3})^2 + (y - 1)^2 = 1$.

Clearly, points E and F satisfy the equations given in option (d).

17. Slope of line joining centre of circle to point D is

$$\tan \theta = \frac{\frac{3}{2} - 1}{\frac{3\sqrt{3}}{2} - \sqrt{3}} = \frac{1}{\sqrt{3}}$$

It makes an angle 30° with X-axis.

\therefore Points E and F will make angle 150° and -90° with X-axis.

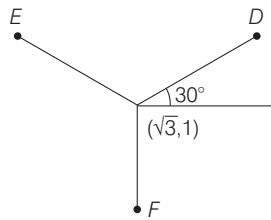

\therefore E and F are given by

$$\frac{x - \sqrt{3}}{\cos 150^\circ} = \frac{y - 1}{\sin 150^\circ} = 1$$

and
$$\frac{x - \sqrt{3}}{\cos (-90^\circ)} = \frac{y - 1}{\sin (-90^\circ)} = 1$$

\therefore
$$E = \left(\frac{\sqrt{3}}{2}, \frac{3}{2} \right) \text{ and } F = (\sqrt{3}, 0)$$

18. Equation of QR, RP are $y = \frac{2}{\sqrt{3}}x + 1$ and $y = -\frac{2}{\sqrt{3}}x - 1$.

19. In an equilateral triangle, the radius of incircle

$$= \frac{1}{3} \times \text{median of the triangle}$$

$$= \frac{1}{3} \sqrt{a^2 - \frac{a^2}{4}} = \frac{1}{3} \sqrt{\frac{4a^2 - a^2}{4}} = \frac{a}{2\sqrt{3}}$$

Therefore, area of the square inscribed in this circle

$$= 2 (\text{radius of circle})^2 = \frac{2a^2}{4 \cdot 3} = \frac{a^2}{6} \text{ sq unit}$$

20. Since, the point of intersection of the coordinate axes with the line $\lambda x - y + 1 = 0$ and $x - 2y + 3 = 0$ forms the circle.

\therefore
$$(\lambda x - y + 1)(x - 2y + 3) = 0$$

represents a circle, if coefficient of $x^2 =$ coefficient of y^2 and coefficient of $xy = 0$

$\Rightarrow \lambda = 2 \quad \text{or} \quad -2\lambda - 1 = 0$

$\Rightarrow \lambda = 2 \quad \text{or} \quad \lambda = -\frac{1}{2}$

21. The equation of circle having tangent $2x + 3y + 1 = 0$ at $(1, -1)$

$$\Rightarrow (x - 1)^2 + (y + 1)^2 + \lambda(2x + 3y + 1) = 0$$

$$x^2 + y^2 + 2x(\lambda - 1) + y(3\lambda + 2) + (\lambda + 2) = 0 \quad \dots(i)$$

which is orthogonal to the circle having end point of diameter $(0, -1)$ and $(-2, 3)$.

$\Rightarrow x(x + 2) + (y + 1)(y - 3) = 0$

or
$$x^2 + y^2 + 2x - 2y - 3 = 0 \quad \dots(ii)$$

$\therefore \frac{2(2\lambda - 2)}{2} \cdot 1 + \frac{2(3\lambda + 2)}{2}(-1) = \lambda + 2 - 3$

$\Rightarrow 2\lambda - 2 - 3\lambda - 2 = \lambda - 1$

$\Rightarrow 2\lambda = -3 \Rightarrow \lambda = -3/2$

From Eq. (i) equation of circle,

$$2x^2 + 2y^2 - 10x - 5y + 1 = 0$$

22. Two circles touch each other externally, if $C_1 C_2 = r_1 + r_2$

and internally if $C_1 C_2 = r_1 - r_2$

Given circles are $x^2 + y^2 - 4x - 2y + 4 = 0$,

whose centre $C_1 (2, 1)$ and radius $r_1 = 1$

and $x^2 + y^2 - 12x - 8y + 36 = 0$

whose centre $C_2 (6, 4)$ and radius $r_2 = 4$

The distance between the centres is

$$\sqrt{(6 - 2)^2 + (4 - 1)^2} = \sqrt{16 + 9} = 5$$

$\Rightarrow C_1 C_2 = r_1 + r_2$

Therefore, the circles touch each other externally and at the point of touching the point divides the line joining the two centres internally in the ratio of their radii, 1 : 4.

Therefore,
$$x_1 = \frac{1 \times 6 + 4 \times 2}{1 + 4} = \frac{14}{5}$$

$$y_1 = \frac{1 \times 4 + 4 \times 1}{1 + 4} = \frac{8}{5}$$

Again, to determine the equations of common tangents touching the circles in distinct points, we know that, the tangents pass through a point which divides the line joining the two centres externally in the ratio of their radii, i.e. 1 : 4.

Therefore,
$$x_2 = \frac{1 \times 6 - 4 \times 2}{1 - 4} = \frac{-2}{-3} = \frac{2}{3}$$

and
$$y_2 = \frac{1 \times 4 - 4 \times 1}{1 - 4} = 0$$

Now, let m be the slope of the tangent and this line passing through $(2/3, 0)$ is

$$y - 0 = m(x - 2/3) \Rightarrow y - mx + \frac{2}{3}m = 0$$

This is tangent to the 1st circle, if perpendicular distance from centre = radius.

$\therefore \frac{1 - 2m + (2/3)m}{\sqrt{1 + m^2}} = 1 \quad [\because C_1 \equiv (2, 1) \text{ and } r_1 = 1]$

$\Rightarrow 1 - 2m + (2/3)m = \sqrt{1 + m^2}$

$\Rightarrow 1 - \frac{4}{3}m = \sqrt{1 + m^2}$

428 Circle

$$\Rightarrow 1 + \frac{16}{9}m^2 - \frac{8}{3}m = 1 + m^2 \Rightarrow \frac{7}{9}m^2 - \frac{8}{3}m = 0$$

$$\Rightarrow m \left(\frac{7}{9}m - \frac{8}{3} \right) = 0 \Rightarrow m = 0, m = \frac{24}{7}$$

Hence, the equations of the two tangents are

$$y = 0 \quad \text{and} \quad y = \frac{24}{7} \left(x - \frac{2}{3} \right)$$

$$\Rightarrow y = 0 \quad \text{and} \quad 7y - 24x + 16 = 0$$

23. We have,

$$\text{Slope of the common tangent} = -\frac{4}{3}$$

$$\therefore \text{Slope of } C_1C_2 = \frac{3}{4}$$

If C_1C_2 makes an angle θ with X -axis, then $\cos\theta = \frac{4}{5}$ and

$$\sin\theta = \frac{3}{5}.$$

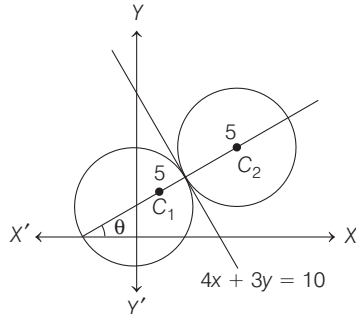

So, the equation of C_1C_2 in parametric form is

$$\frac{x-1}{4/5} = \frac{y-2}{3/5} \quad \dots(i)$$

Since, C_1 and C_2 are points on Eq. (i) at a distance of 5 units from P .

So, the coordinates of C_1 and C_2 are given by

$$\frac{x-1}{4/5} = \frac{y-2}{3/5} = \pm 5 \Rightarrow x = 1 \pm 4$$

and $y = 2 \pm 3$.

Thus, the coordinates of C_1 and C_2 are $(5, 5)$ and $(-3, -1)$, respectively.

Hence, the equations of the two circles are

$$(x-5)^2 + (y-5)^2 = 5^2 \quad \text{and} \quad (x+3)^2 + (y+1)^2 = 5^2$$

24. According to given informations the figure is as following

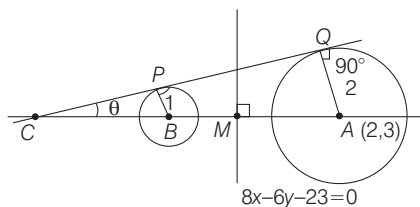

$$\text{From the figure, } AC = \frac{2}{\sin\theta} \quad \dots(i)$$

$$\therefore \sin\theta = \frac{1}{CB} \quad (\text{from } \triangle CPB) \quad \dots(ii)$$

$$\text{and } \sin\theta = \frac{2}{AC} = \frac{2}{CB+AB} \quad (\text{from } \triangle CQA) \quad \dots(iii)$$

$$\therefore AB = AM + MB = 2AM \quad [\because AM = MB]$$

$$= 2 \frac{|(8 \times 2) - (6 \times 3) - 23|}{\sqrt{64+36}} = \frac{2 \times 25}{10} = 5.00$$

From Eqs. (ii) and (iii), we get

$$\sin\theta = \frac{1}{CB} = \frac{2}{CB+AB} \Rightarrow \frac{1}{CB} = \frac{2}{CB+5} \quad [\because AB = 5]$$

$$\Rightarrow CB+5 = 2CB \Rightarrow CB = 5 = \frac{1}{\sin\theta}$$

From the Eq. (i),

$$AC = \frac{2}{\sin\theta} = 2 \times 5 = 10.00$$

$$25. (r+1)^2 = \alpha^2 + 9$$

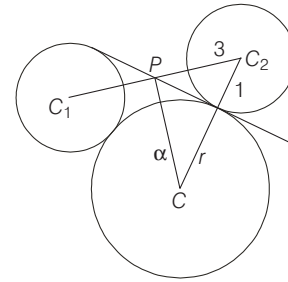

$$r^2 + 8 = \alpha^2$$

$$\Rightarrow r^2 + 2r + 1 = r^2 + 8 + 9$$

$$\Rightarrow 2r = 16 \Rightarrow r = 8$$

Topic 4 Radical Axis and Family of Circle

1. Let (h, k) be the centre of the circle and radius $r = h$, as circle touch the Y -axis and other circle $x^2 + y^2 = 1$ whose centre $(0, 0)$ and radius is 1.

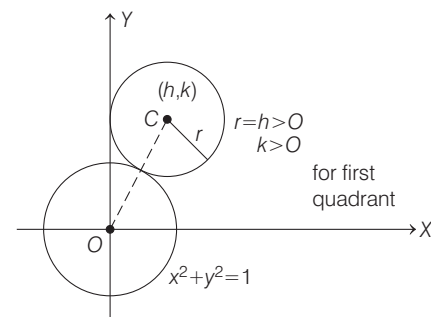

$$\therefore OC = r + 1$$

[\because if circles touch each other externally, then $C_1C_2 = r_1 + r_2$]

$$\Rightarrow \sqrt{h^2 + k^2} = h + 1, h > 0$$

and $k > 0$, for first quadrant.

$$\Rightarrow h^2 + k^2 = h^2 + 2h + 1 \Rightarrow k^2 = 2h + 1$$

$$\Rightarrow k = \sqrt{1 + 2h}, \text{ as } k > 0$$

Now, on taking locus of centre (h, k) , we get

$$y = \sqrt{1 + 2x}, x \geq 0$$

2. Since, the equation of a family of circles touching line $L=0$ at their point of contact (x_1, y_1) is $(x-x_1)^2 + (y-y_1)^2 + \lambda L=0$, where $\lambda \in R$.

\therefore Equation of circle, touches the $x=y$ at point $(1, 1)$ is
 $(x-1)^2 + (y-1)^2 + \lambda(x-y)=0$
 $\Rightarrow x^2 + y^2 + (\lambda-2)x + (-\lambda-2)y + 2=0$... (i)
 \therefore Circle (i) passes through point $(1, -3)$.
 $\therefore 1+9+(\lambda-2)+3(-\lambda-2)+2=0$
 $\Rightarrow 4\lambda+16=0$
 $\Rightarrow \lambda=-4$

So, equation of circle (i) at $\lambda=-4$, is
 $x^2 + y^2 - 6x + 2y + 2=0$

Now, radius of the circle $=\sqrt{9+1-2}=2\sqrt{2}$.

3. Clearly, circles are orthogonal because tangent at one point of intersection is passing through centre of the other.

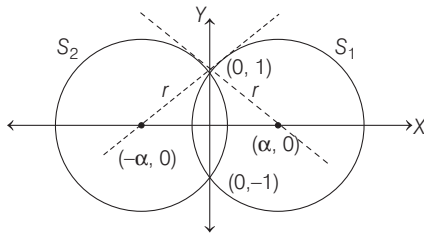

Let $C_1(\alpha, 0)$ and $C_2(-\alpha, 0)$ are the centres.
 Then, $S_1 \equiv (x-\alpha)^2 + y^2 = \alpha^2 + 1$
 $\Rightarrow S_1 \equiv x^2 + y^2 - 2\alpha x - 1 = 0$
 [\because radius, $r = \sqrt{(\alpha-0)^2 + (0-1)^2}$]

and $S_2 \equiv (x+\alpha)^2 + y^2 = \alpha^2 + 1$
 $\Rightarrow S_2 \equiv x^2 + y^2 + 2\alpha x - 1 = 0$
 Now, $2(\alpha)(-\alpha) + 2 \cdot 0 \cdot 0 = (-1) + (-1) \Rightarrow \alpha = \pm 1$
 [\because condition of orthogonality is $2g_1g_2 + 2f_1f_2 = c_1 + c_2$]
 $\therefore C_1(1, 0)$ and $C_2(-1, 0) \Rightarrow C_1C_2 = 2$

4. According to given information, we have the following figure.

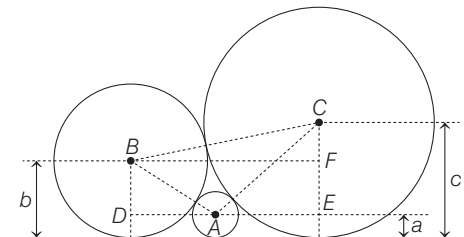

where A, B, C are the centres of the circles
 Clearly, $AB = a + b$ (sum of radii) and $BD = b - a$
 $\therefore AD = \sqrt{(a+b)^2 - (b-a)^2}$
 (using Pythagoras theorem in $\triangle ABD$)
 $= 2\sqrt{ab}$

Similarly, $AC = a + c$ and $CE = c - a$
 \therefore In $\triangle ACE$, $AE = \sqrt{(a+c)^2 - (c-a)^2} = 2\sqrt{ac}$
 Similarly, $BC = b + c$ and $CF = c - b$

\therefore In $\triangle BCF$, $BF = \sqrt{(b+c)^2 - (c-b)^2} = 2\sqrt{bc}$
 $\therefore AD + AE = BF$
 $\therefore 2\sqrt{ab} + 2\sqrt{ac} = 2\sqrt{bc} \Rightarrow \frac{1}{\sqrt{c}} + \frac{1}{\sqrt{b}} = \frac{1}{\sqrt{a}}$

5. Let the equation of circle be
 $(x-3)^2 + (y-0)^2 + \lambda y = 0$

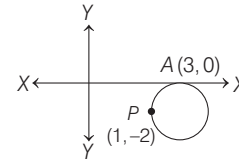

As it passes through $(1, -2)$
 $\therefore (1-3)^2 + (-2)^2 + \lambda(-2) = 0 \Rightarrow 4+4-2\lambda=0 \Rightarrow \lambda=4$
 \therefore Equation of circle is

$$(x-3)^2 + y^2 + 4y = 0$$

By hit and trial method, we see that point $(5, -2)$ satisfies equation of circle.

6. Equation of circle passing through a point (x_1, y_1) and touching the straight line L , is given by

$$(x-x_1)^2 + (y-y_1)^2 + \lambda L = 0$$

\therefore Equation of circle passing through $(0, 2)$ and touching $x=0$
 $\Rightarrow (x-0)^2 + (y-2)^2 + \lambda x = 0$... (i)

Also, it passes through $(-1, 0) \Rightarrow 1+4-\lambda=0$
 $\therefore \lambda=5$

Eq. (i) becomes,
 $x^2 + y^2 - 4y + 4 + 5x = 0$
 $\Rightarrow x^2 + y^2 + 5x - 4y + 4 = 0$

For x -intercept put $y=0 \Rightarrow x^2 + 5x + 4 = 0$
 $(x+1)(x+4) = 0$

$$\therefore x = -1, -4$$

Hence, (d) option $(-4, 0)$.

7. Let the locus of centre of circle be (h, k) touching $(y-1)^2 + x^2 = 1$ and X -axis shown as

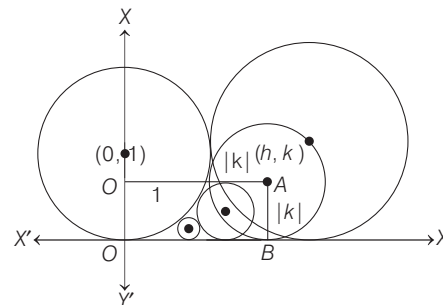

Clearly, from figure,
 Distance between C and A is always $1 + |k|$,
 i.e. $\sqrt{(h-0)^2 + (k-1)^2} = 1 + |k|$,
 $\Rightarrow h^2 + k^2 - 2k + 1 = 1 + k^2 + 2|k|$

430 Circle

$$\Rightarrow h^2 = 2|k| + 2k \Rightarrow x^2 = 2|y| + 2y$$

$$\text{where } |y| = \begin{cases} y, & y \geq 0 \\ -y, & y < 0 \end{cases}$$

$$\therefore x^2 = 2y + 2y, y \geq 0$$

$$\text{and } x^2 = -2y + 2y, y < 0$$

$$\Rightarrow x^2 = 4y, \text{ when } y \geq 0$$

$$\text{and } x^2 = 0, \text{ when } y < 0$$

$$\therefore \{(x, y): x^2 = 4y, \text{ when } y \geq 0\} \cup \{(0, y): y < 0\}$$

- 8. NOTE** In solving a line and a circle there oftengenerate a quadratic equation and further we have to apply condition of Discriminant so question convert from coordinate to quadratic equation.

From equation of circle it is clear that circle passes through origin. Let AB is chord of the circle.

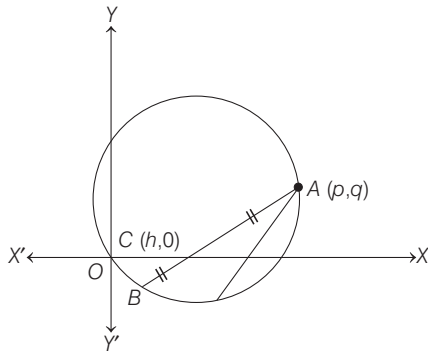

$A \equiv (p, q)$ · C is mid-point and coordinate of C is $(h, 0)$

Then, coordinates of B are $(-p + 2h, -q)$ and B lies on the circle $x^2 + y^2 = px + qy$, we have

$$(-p + 2h)^2 + (-q)^2 = p(-p + 2h) + q(-q)$$

$$\Rightarrow p^2 + 4h^2 - 4ph + q^2 = -p^2 + 2ph - q^2$$

$$\Rightarrow 2p^2 + 2q^2 - 6ph + 4h^2 = 0$$

$$\Rightarrow 2h^2 - 3ph + p^2 + q^2 = 0 \quad \dots(i)$$

There are given two distinct chords which are bisected at X -axis then, there will be two distinct values of h satisfying Eq. (i).

So, discriminant of this quadratic equation must be > 0 .

$$\Rightarrow D > 0$$

$$\Rightarrow (-3p)^2 - 4 \cdot 2(p^2 + q^2) > 0$$

$$\Rightarrow 9p^2 - 8p^2 - 8q^2 > 0$$

$$\Rightarrow p^2 - 8q^2 > 0 \Rightarrow p^2 > 8q^2$$

- 9.** Let (h, k) be the centre of the circle which touches the circle $x^2 + y^2 - 6x - 6y + 14 = 0$ and Y -axis.

The centre of given circle is $(3, 3)$ and radius is $\sqrt{3^2 + 3^2 - 14} = \sqrt{9 + 9 - 14} = 2$

Since, the circle touches Y -axis, the distance from its centre to Y -axis must be equal to its radius, therefore its radius is h . Again, the circles meet externally, therefore the distance between two centres = sum of the radii of the two circles.

$$\text{Hence, } (h - 3)^2 + (k - 3)^2 = (2 + h)^2$$

$$h^2 + 9 - 6h + k^2 + 9 - 6k = 4 + h^2 + 4h$$

$$\text{i.e. } k^2 - 10h - 6k + 14 = 0$$

Thus, the locus of (h, k) is

$$y^2 - 10x - 6y + 14 = 0$$

- 10.** Let $C_1(h, k)$ be the centre of the required circle. Then,

$$\sqrt{(h - 0)^2 + (k - 0)^2} = \sqrt{(h - 1)^2 + (k - 0)^2}$$

$$\Rightarrow h^2 + k^2 = h^2 - 2h + 1 + k^2$$

$$\Rightarrow -2h + 1 = 0 \Rightarrow h = 1/2$$

Since, $(0, 0)$ and $(1, 0)$ lie inside the circle $x^2 + y^2 = 9$. Therefore, the required circle can touch the given circle internally.

$$\text{i.e. } C_1 \cdot C_2 = r_1 \sim r_2$$

$$\Rightarrow \sqrt{h^2 + k^2} = 3 - \sqrt{h^2 + k^2}$$

$$\Rightarrow 2\sqrt{h^2 + k^2} = 3 \Rightarrow 2\sqrt{\frac{1}{4} + k^2} = 3$$

$$\Rightarrow \sqrt{\frac{1}{4} + k^2} = \frac{3}{2} \Rightarrow \frac{1}{4} + k^2 = \frac{9}{4}$$

$$\Rightarrow k^2 = 2 \Rightarrow k = \pm\sqrt{2}$$

- 11.** The required equation of circle is

$$(x^2 + y^2 + 13x - 3y) + \lambda \left(11x + \frac{1}{2}y + \frac{25}{2} \right) = 0 \quad \dots(i)$$

Its passing through $(1, 1)$,

$$\Rightarrow 12 + \lambda(24) = 0$$

$$\Rightarrow \lambda = -\frac{1}{2}$$

On putting in Eq. (i), we get

$$x^2 + y^2 + 13x - 3y - \frac{11}{2}x - \frac{1}{4}y - \frac{25}{4} = 0$$

$$\Rightarrow 4x^2 + 4y^2 + 52x - 12y - 22x - y - 25 = 0$$

$$\Rightarrow 4x^2 + 4y^2 + 30x - 13y - 25 = 0$$

- 12.** The required equation of circle is, $S_1 + \lambda(S_2 - S_1) = 0$.

$$\therefore (x^2 + y^2 - 6) + \lambda(-6x + 14) = 0$$

Also, passing through $(1, 1)$.

$$\Rightarrow -4 + \lambda(8) = 0$$

$$\Rightarrow \lambda = \frac{1}{2}$$

\therefore Required equation of circle is

$$x^2 + y^2 - 6 - 3x + 7 = 0$$

$$\text{or } x^2 + y^2 - 3x + 1 = 0$$

- 13.** It is given that, C_1 has centre $(0, 0)$ and radius 1.

Similarly, C_2 has centre $(0, 0)$ and radius 2 and C_k has centre $(0, 0)$ and radius k .

Now, particle starts its motion from $(1, 0)$ and moves 1 radian on first circle then particle shifts from C_1 to C_2 .

After that, particle moves 1 radian on C_2 and then particle shifts from C_2 to C_3 . Similarly, particle move on n circles.

Now, $n \geq 2\pi$ because particle crosses the X -axis for the first time on C_n , then n is least positive integer.

Therefore, $n = 7$.

14. Equation of any circle passing through the point of intersection of $x^2 + y^2 - 2x = 0$ and $y = x$ is

$$(x^2 + y^2 - 2x) + \lambda(y - x) = 0$$

$$\Rightarrow x^2 + y^2 - (2 + \lambda)x + \lambda y = 0$$

Its centre is $\left(\frac{2 + \lambda}{2}, \frac{-\lambda}{2}\right)$.

\Rightarrow For AB to be the diameter of the required circle the centre must be on AB , i.e.

$$2 + \lambda = -\lambda \Rightarrow \lambda = -1 \quad [\because y = x]$$

Therefore, equation of the required circle is

$$x^2 + y^2 - (2 - 1)x - 1 \cdot y = 0$$

$$\Rightarrow x^2 + y^2 - x - y = 0$$

15. Given, $C_1: x^2 + y^2 = 16$

and let $C_2: (x - h)^2 + (y - k)^2 = 25$

\therefore Equation of common chords is $S_1 - S_2 = 0$

$$\therefore 2hx + 2ky = (h^2 + k^2 - 9)$$

$$\therefore \text{Its slope} = -\frac{h}{k} = \frac{3}{4} \quad [\text{given}]$$

If p be the length of perpendicular on it from the centre $(0, 0)$ of C_1 of radius 4, then $p = \frac{h^2 + k^2 - 9}{\sqrt{4h^2 + 4k^2}}$.

Also, the length of the chord is

$$2\sqrt{r^2 - p^2} = 2\sqrt{4^2 - p^2}$$

The chord will be of maximum length, if $\phi = 0$ or

$$h^2 + k^2 - 9 = 0 \Rightarrow h^2 + \frac{16}{9}h^2 = 9$$

$$\Rightarrow h = \pm \frac{9}{5}$$

$$\therefore k = \mp \frac{12}{5}$$

Hence, centres are $\left(\frac{9}{5}, -\frac{12}{5}\right)$ and $\left(-\frac{9}{5}, \frac{12}{5}\right)$

16. For point of intersection, we put

$$x = \frac{3y + 10}{4} \text{ in } x^2 + y^2 - 2x + 4y - 20 = 0$$

$$\Rightarrow \left(\frac{3y + 10}{4}\right)^2 + y^2 - 2\left(\frac{3y + 10}{4}\right) + 4y - 20 = 0$$

$$\Rightarrow 25y^2 + 100y - 300 = 0$$

$$\Rightarrow y^2 + 4y - 12 = 0$$

$$\Rightarrow (y - 2)(y + 6) = 0$$

$$\Rightarrow y = -6, 2$$

When $y = -6 \Rightarrow x = -2$

When $y = 2 \Rightarrow x = 4$

\therefore Point of intersection are $(-2, -6)$ and $(4, 2)$.

17. Equation of any tangent to circle $x^2 + y^2 = r^2$ is

$$x \cos \theta + y \sin \theta = r \quad \dots (i)$$

Suppose Eq. (i) is tangent to $4x^2 + 25y^2 = 100$

or $\frac{x^2}{25} + \frac{y^2}{4} = 1$ at (x_1, y_1)

Then, Eq. (i) and $\frac{xx_1}{25} + \frac{yy_1}{4} = 1$ are identical

$$\therefore \frac{x_1/25}{\cos \theta} = \frac{y_1/4}{\sin \theta} = \frac{1}{r}$$

$$\Rightarrow x_1 = \frac{25 \cos \theta}{r}, y_1 = \frac{4 \sin \theta}{r}$$

The line (i) meet the coordinates axes in $A (r \sec \theta, 0)$ and $\beta (0, r \operatorname{cosec} \theta)$. Let (h, k) be mid-point of AB .

Then, $h = \frac{r \sec \theta}{2}$ and $k = \frac{r \operatorname{cosec} \theta}{2}$

Therefore, $2h = \frac{r}{\cos \theta}$ and $2k = \frac{r}{\sin \theta}$

$$\therefore x_1 = \frac{25}{2h} \quad \text{and} \quad y_1 = \frac{4}{2k}$$

As (x_1, y_1) lies on the ellipse $\frac{x^2}{25} + \frac{y^2}{4} = 1$, we get

$$\frac{1}{25} \left(\frac{625}{4h^2}\right) + \frac{1}{4} \left(\frac{4}{k^2}\right) = 1 \Rightarrow \frac{25}{4h^2} + \frac{1}{k^2} = 1$$

or $25k^2 + 4h^2 = 4h^2 k^2$

Therefore, required locus is $4x^2 + 25y^2 = 4x^2 y^2$

18. The equation of the circle on the line joining the points $A(3, 7)$ and $B(6, 5)$ as diameter is

$$(x - 3)(x - 6) + (y - 7)(y - 5) = 0 \quad \dots (i)$$

and the equation of the line joining the points $A(3, 7)$ and $B(6, 5)$ is $y - 7 = \frac{7 - 5}{3 - 6}(x - 3)$

$$\Rightarrow 2x + 3y - 27 = 0 \quad \dots (ii)$$

Now, the equation of family of circles passing through the point of intersection of Eqs. (i) and (ii) is

$$S + \lambda P = 0$$

$$\Rightarrow (x - 3)(x - 6) + (y - 7)(y - 5) + \lambda(2x + 3y - 27) = 0$$

$$\Rightarrow x^2 - 6x - 3x + 18 + y^2 - 5y - 7y + 35 + 2\lambda x + 3\lambda y - 27\lambda = 0$$

$$\Rightarrow S_1 \equiv x^2 + y^2 + x(2\lambda - 9) + y(3\lambda - 12) + (53 - 27\lambda) = 0 \quad \dots (iii)$$

Again, the circle, which cuts the members of family of circles, is

$$S_2 \equiv x^2 + y^2 - 4x - 6y - 3 = 0 \quad \dots (iv)$$

and the equation of common chord to circles S_1 and S_2 is

$$S_1 - S_2 = 0$$

$$\Rightarrow x(2\lambda - 9 + 4) + y(3\lambda - 12 + 6) + (53 - 27\lambda + 3) = 0$$

$$\Rightarrow 2\lambda x - 5x + 3\lambda y - 6y + 56 - 27\lambda = 0$$

$$\Rightarrow (-5x - 6y + 56) + \lambda(2x + 3y - 27) = 0$$

which represents equations of two straight lines passing through the fixed point whose coordinates are obtained by solving the two equations

$$5x + 6y - 56 = 0 \quad \text{and} \quad 2x + 3y - 27 = 0,$$

we get $x = 2$ and $y = 23/3$

432 Circle

19. The parametric form of OP is

$$\frac{x-0}{\cos 45^\circ} = \frac{y-0}{\sin 45^\circ}$$

Since,

$$OP = 4\sqrt{2}$$

So, the coordinates of P are given by

$$\frac{x-0}{\cos 45^\circ} = \frac{y-0}{\sin 45^\circ} = -4\sqrt{2}$$

So,

$$P(-4, -4)$$

Let $C(h, k)$ be the centre of circle and r be its radius.

Now, $CP \perp OP$

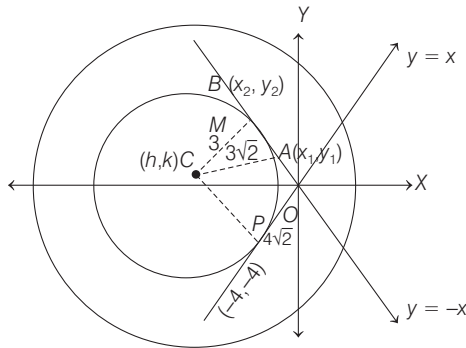

$$\Rightarrow \frac{k+4}{h+4} \cdot (1) = -1$$

$$\Rightarrow k+4 = -h-4$$

$$\Rightarrow h+k = -8 \quad \dots(i)$$

Also, $CP^2 = (h+4)^2 + (k+4)^2$

$$\Rightarrow (h+4)^2 + (k+4)^2 = r^2 \quad \dots(ii)$$

In $\triangle ACM$, we have

$$AC^2 = (3\sqrt{2})^2 + \left(\frac{h+k}{\sqrt{2}}\right)^2$$

$$\Rightarrow r^2 = 18 + 32$$

$$\Rightarrow r = 5\sqrt{2} \quad \dots(iii)$$

Also, $CP = r$

$$\Rightarrow \left| \frac{h-k}{\sqrt{2}} \right| = r$$

$$\Rightarrow h-k = \pm 10 \quad \dots(iv)$$

From Eqs. (i) and (iv), we get

$$(h = -9, k = 1)$$

or $(h = 1, k = -9)$

Thus, the equation of the circles are

$$(x+9)^2 + (y-1)^2 = (5\sqrt{2})^2$$

or $(x-1)^2 + (y+9)^2 = (5\sqrt{2})^2$

$$\Rightarrow x^2 + y^2 + 18x - 2y + 32 = 0$$

or $x^2 + y^2 - 2x + 18y + 32 = 0$

Clearly, $(-10, 2)$ lies interior of

$$x^2 + y^2 + 18x - 2y + 32 = 0$$

Hence, the required equation of circle, is

$$x^2 + y^2 + 18x - 2y + 32 = 0$$

20. Let $P(h, k)$ be the foot of perpendicular drawn from origin $O(0, 0)$ on the chord AB of the given circle such that the chord AB subtends a right angle at the origin.

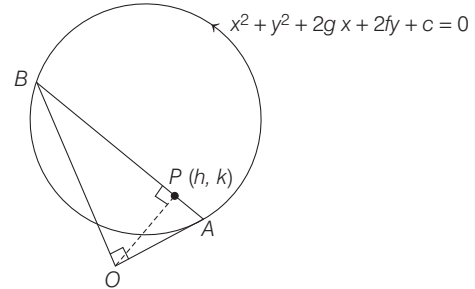

The equation of chord AB is

$$y - k = -\frac{h}{k}(x - h) \Rightarrow hx + ky = h^2 + k^2$$

The combined equation of OA and OB is homogeneous equation of second degree obtained by the help of the given circle and the chord AB and is given by,

$$x^2 + y^2 + (2gx + 2fy) \left(\frac{hx + ky}{h^2 + k^2} \right) + c \left(\frac{hx + ky}{h^2 + k^2} \right)^2 = 0$$

Since, the lines OA and OB are at right angle.

\therefore Coefficient of x^2 + Coefficient of y^2 = 0

$$\Rightarrow \left\{ 1 + \frac{2gh}{h^2 + k^2} + \frac{ch^2}{(h^2 + k^2)^2} \right\}$$

$$+ \left\{ 1 + \frac{2fk}{h^2 + k^2} + \frac{ck^2}{(h^2 + k^2)^2} \right\} = 0$$

$$\Rightarrow 2(h^2 + k^2) + 2(gh + fk) + c = 0$$

$$\Rightarrow h^2 + k^2 + gh + fk + \frac{c}{2} = 0$$

\therefore Required equation of locus is

$$x^2 + y^2 + gx + fy + \frac{c}{2} = 0$$

21. Let the equation of L_1 be $x \cos \alpha + y \sin \alpha = p_1$.

Then, any line perpendicular to L_1 is

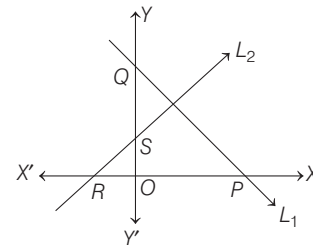

$$x \sin \alpha - y \cos \alpha = p_2$$

where, p_2 is a variable.

Then, L_1 meets X -axis at $P(p_1 \sec \alpha, 0)$ and Y -axis at $Q(0, p_1 \csc \alpha)$.

Similarly, L_2 meets X -axis at $R(p_2 \csc \alpha, 0)$ and Y -axis at $S(0, -p_2 \sec \alpha)$.

Now, equation of PS is,

$$\frac{x}{p_1 \sec \alpha} + \frac{y}{-p_2 \sec \alpha} = 1 \Rightarrow \frac{x}{p_1} - \frac{y}{p_2} = \sec \alpha \quad \dots(i)$$

Similarly, equation of QR is

$$\frac{x}{p_2 \operatorname{cosec} \alpha} + \frac{y}{p_1 \operatorname{cosec} \alpha} = 1 \Rightarrow \frac{x}{p_2} + \frac{y}{p_1} = \operatorname{cosec} \alpha \quad \dots(\text{ii})$$

Locus of point of intersection of PS and QR can be obtained by eliminating the variable p_2 from Eqs. (i) and (ii).

$$\begin{aligned} \therefore \left(\frac{x}{p_1} - \sec \alpha \right) \frac{x}{y} + \frac{y}{p_1} &= \operatorname{cosec} \alpha \\ \Rightarrow (x - p_1 \sec \alpha) x + y^2 &= p_1 y \operatorname{cosec} \alpha \\ \Rightarrow x^2 + y^2 - p_1 x \sec \alpha - p_1 y \operatorname{cosec} \alpha &= 0 \end{aligned}$$

which is a circle through origin.

22. Let the equation of the required circle be

$$x^2 + y^2 + 2gx + 2fy + c = 0 \quad \dots(\text{i})$$

It passes through $(-4, 3)$.

$$\therefore 25 - 8g + 6f + c = 0 \quad \dots(\text{ii})$$

Since, circle touches the line $x + y - 2 = 0$ and $x - y - 2 = 0$.

$$\therefore \left| \frac{-g - f - 2}{\sqrt{2}} \right| = \left| \frac{-g + f - 2}{\sqrt{2}} \right| = \sqrt{g^2 + f^2 - c} \quad \dots(\text{iii})$$

Now,

$$\left| \frac{-g - f - 2}{\sqrt{2}} \right| = \left| \frac{-g + f - 2}{\sqrt{2}} \right|$$

$$\Rightarrow -g - f - 2 = \pm (-g + f - 2)$$

$$\Rightarrow -g - f - 2 = -g + f - 2$$

or

$$-g - f - 2 = g - f + 2$$

$$\Rightarrow f = 0 \text{ or } g = -2$$

Case I When $f = 0$

From Eq. (iii), we get

$$\left| \frac{-g - 2}{\sqrt{2}} \right| = \sqrt{g^2 - c}$$

$$\Rightarrow (g + 2)^2 = 2(g^2 - c)$$

$$\Rightarrow g^2 - 4g - 4 - 2c = 0 \quad \dots(\text{iv})$$

On putting $f = 0$ in Eq. (ii), we get

$$25 - 8g + c = 0 \quad \dots(\text{v})$$

Eliminating c between Eqs. (iv) and (v), we get

$$g^2 - 20g + 46 = 0$$

$$\Rightarrow g = 10 \pm 3\sqrt{6} \text{ and } c = 55 \pm 24\sqrt{6}$$

On substituting the values of g, f and c in Eq. (i), we get

$$x^2 + y^2 + 2(10 \pm 3\sqrt{6})x + (55 \pm 24\sqrt{6}) = 0$$

Case II When $g = -2$

From Eq. (iii), we get

$$\Rightarrow f^2 = 2(4 + f^2 - c)$$

$$\Rightarrow f^2 - 2c + 8 = 0 \quad \dots(\text{vi})$$

On putting $g = -2$ in Eq. (ii), we get

$$c = -6f - 41$$

On substituting c in Eq. (vi), we get

$$f^2 + 12f + 90 = 0$$

This equation gives imaginary values of f .

Thus, there is no circle in this case.

Hence, the required equations of the circles are

$$x^2 + y^2 + 2(10 \pm 3\sqrt{6})x + (55 \pm 24\sqrt{6}) = 0$$

23. Given lines are

$$3x + 5y - 1 = 0 \quad \dots(\text{i})$$

$$\text{and } (2 + c)x + 5c^2y - 1 = 0 \quad \dots(\text{ii})$$

$$\therefore \frac{x}{-5 + 5c^2} = \frac{y}{-(2 + c) + 3} = \frac{1}{15c^2 - 5c - 10}$$

$$\Rightarrow x = \frac{5(c^2 - 1)}{5(3c^2 - c - 2)} \text{ and } y = \frac{1 - c}{15c^2 - 5c - 10}$$

$$\Rightarrow \lim_{c \rightarrow 1} x = \lim_{c \rightarrow 1} \frac{2c}{6c - 1}$$

$$\text{and } \lim_{c \rightarrow 1} y = \lim_{c \rightarrow 1} \frac{-1}{30c - 5} \Rightarrow \lim_{c \rightarrow 1} x = \frac{2}{5} \text{ and } \lim_{c \rightarrow 1} y = -\frac{1}{25}$$

$$\therefore \text{Centre} = \left(\lim_{c \rightarrow 1} x, \lim_{c \rightarrow 1} y \right) = \left(\frac{2}{5}, -\frac{1}{25} \right)$$

$$\therefore \text{Radius} = \sqrt{\left(2 - \frac{2}{5} \right)^2 + \left(0 + \frac{1}{25} \right)^2} = \sqrt{\frac{64}{25} + \frac{1}{625}} = \frac{\sqrt{1601}}{25}$$

$$\therefore \text{Equation of the circle is } \left(x - \frac{2}{5} \right)^2 + \left(y + \frac{1}{25} \right)^2 = \frac{1601}{625}$$

$$\Rightarrow x^2 + y^2 - \frac{4x}{5} + \frac{2y}{25} + \frac{4}{25} + \frac{1}{625} - \frac{1601}{625} = 0$$

$$\Rightarrow 25(x^2 + y^2) - 20x + 2y - 60 = 0$$

Topic 5 Equation of Chord Bisected at a Point, Product of Pair of Tangents, Chord of Contact of Tangent, Pole and Equations of Polar

- Key Idea** Firstly find the centre of the given circle and write the coordinates of mid point (A), of line segment PQ , since $AC \perp PQ$ therefore use (slope of AC) \times (slope of PQ) = -1

It is given that points P and Q are intersecting points of circle

$$(x - 3)^2 + (y + 2)^2 = 25 \quad \dots(\text{i})$$

$$\text{Line } y = mx + 1 \quad \dots(\text{ii})$$

And, the mid-point of PQ is A having x -coordinate $\frac{-3}{5}$ so

y -coordinate is $1 - \frac{3}{5}m$.

$$\text{So, } A \left(-\frac{3}{5}, 1 - \frac{3}{5}m \right)$$

From the figure,

$\therefore AC \perp PQ$

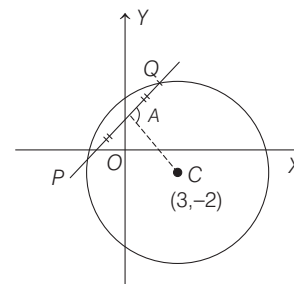

434 Circle

$$\Rightarrow (\text{slope of } AC) \times (\text{slope of } PQ) = -1$$

$$\Rightarrow \left(\frac{-2-1+\frac{3}{5}m}{3+\frac{3}{5}} \right) \times m = -1$$

$$\Rightarrow \frac{(3/5)m-3}{18/5} m = -1 \Rightarrow \left(\frac{3m-15}{18} \right) m = -1$$

$$\Rightarrow 3m^2 - 15m + 18 = 0 \Rightarrow m^2 - 5m + 6 = 0$$

$$\Rightarrow m = 2 \text{ or } 3$$

2. Let the length of common chord = $AB = 2AM = 2x$

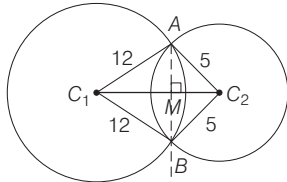

$$\text{Now, } C_1C_2 = \sqrt{AC_1^2 + AC_2^2} \quad \dots (i)$$

[\because circles intersect each other at 90°]

$$\text{and } C_1C_2 = C_1M + MC_2$$

$$\Rightarrow C_1C_2 = \sqrt{12^2 - AM^2} + \sqrt{5^2 - AM^2} \quad \dots (ii)$$

From Eqs. (i) and (ii), we get

$$\sqrt{AC_1^2 + AC_2^2} = \sqrt{144 - AM^2} + \sqrt{25 - AM^2}$$

$$\Rightarrow \sqrt{144 + 25} = \sqrt{144 - x^2} + \sqrt{25 - x^2}$$

$$\Rightarrow 13 = \sqrt{144 - x^2} + \sqrt{25 - x^2}$$

On squaring both sides, we get

$$169 = 144 - x^2 + 25 - x^2 + 2\sqrt{144 - x^2} \sqrt{25 - x^2}$$

$$\Rightarrow x^2 = \sqrt{144 - x^2} \sqrt{25 - x^2}$$

Again, on squaring both sides, we get

$$x^4 = (144 - x^2)(25 - x^2) = (144 \times 25) - (25 + 144)x^2 + x^4$$

$$\Rightarrow x^2 = \frac{144 \times 25}{169}$$

$$\Rightarrow x = \frac{12 \times 5}{13} = \frac{60}{13} \text{ cm}$$

$$\text{Now, length of common chord } 2x = \frac{120}{13} \text{ cm}$$

Alternate Solution

Given, $AC_1 = 12$ cm and $AC_2 = 5$ cm

In ΔC_1AC_2 ,

$$C_1C_2 = \sqrt{(C_1A)^2 + (AC_2)^2} \quad [\because \angle C_1AC_2 = 90^\circ, \text{ because circles intersect each other at } 90^\circ]$$

$$= \sqrt{(12)^2 + (5)^2} = \sqrt{144 + 25}$$

$$= \sqrt{169} = 13 \text{ cm}$$

$$\begin{aligned} \text{Now, area of } \Delta C_1AC_2 &= \frac{1}{2} AC_1 \times AC_2 \\ &= \frac{1}{2} \times 12 \times 5 = 30 \text{ cm}^2 \end{aligned}$$

$$\text{Also, area of } \Delta C_1AC_2 = \frac{1}{2} C_1C_2 \times AM$$

$$= \frac{1}{2} \times 13 \times \frac{AB}{2} \quad \left[\because AM = \frac{AB}{2} \right]$$

$$\therefore \frac{1}{4} \times 13 \times AB = 30 \text{ cm}$$

$$AB = \frac{120}{13} \text{ cm}$$

3. Given equation of line is $x + y = n, n \in N$... (i)
and equation of circle is $x^2 + y^2 = 16$... (ii)
Now, for intercept, made by circle (ii) with line (i)

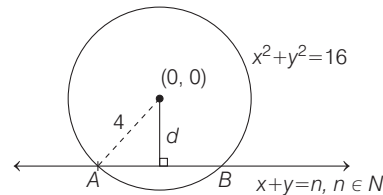

$$d < 4$$

$$\Rightarrow \frac{n}{\sqrt{2}} < 4$$

[\because d = perpendicular distance from $(0, 0)$ to the line

$$x + y = n \text{ and it equal to } \frac{|0+0-n|}{\sqrt{1^2+1^2}} = \frac{n}{\sqrt{2}}$$

$$\Rightarrow n < 4\sqrt{2} \quad \dots (iii)$$

$\therefore n \in N$, so $n = 1, 2, 3, 4, 5$

Clearly, length of chord $AB = 2\sqrt{4^2 - d^2}$

$$= 2\sqrt{16 - \frac{n^2}{2}} \quad \left[\because d = \frac{n}{\sqrt{2}} \right]$$

\therefore Sum of square of all possible lengths of chords (for $n = 1, 2, 3, 4, 5$)

$$= 4 \left[(16 \times 5) - \frac{1}{2} (1^2 + 2^2 + 3^2 + 4^2 + 5^2) \right]$$

$$= 320 - 2 \frac{5(6)(11)}{6}$$

$$= 320 - 110 = 210$$

4. Given equation of circle is

$$x^2 + y^2 - 8x - 8y - 4 = 0, \text{ whose centre is } C(4, 4) \text{ and radius } = \sqrt{4^2 + 4^2 + 4} = \sqrt{36} = 6$$

Let the centre of required circle be $C_1(x, y)$. Now, as it touch the X -axis, therefore its radius = $|y|$. Also, it touch the circle

$$x^2 + y^2 - 8x - 8y - 4 = 0 \text{ therefore } CC_1 = 6 + |y|$$

$$\Rightarrow \sqrt{(x-4)^2 + (y-4)^2} = 6 + |y|$$

$$\Rightarrow x^2 + 16 - 8x + y^2 + 16 - 8y = 36 + y^2 + 12|y|$$

$$\Rightarrow x^2 - 8x - 8y + 32 = 36 + 12|y|$$

$$\Rightarrow x^2 - 8x - 8y - 4 = 12|y|$$

Case I If $y > 0$, then we have

$$x^2 - 8x - 8y - 4 = 12y$$

$$\begin{aligned} \Rightarrow x^2 - 8x - 20y - 4 &= 0 \\ \Rightarrow x^2 - 8x - 4 &= 20y \\ \Rightarrow (x - 4)^2 - 20 &= 20y \\ \Rightarrow (x - 4)^2 &= 20(y + 1) \text{ which is a parabola.} \end{aligned}$$

Case II If $y < 0$, then we have

$$\begin{aligned} x^2 - 8x - 8y - 4 &= -12y \\ \Rightarrow x^2 - 8x - 8y - 4 + 12y &= 0 \\ \Rightarrow x^2 - 8x + 4y - 4 &= 0 \\ \Rightarrow x^2 - 8x - 4 &= -4y \\ \Rightarrow (x - 4)^2 &= 20 - 4y \\ \Rightarrow (x - 4)^2 &= -4(y - 5), \text{ which is again a parabola.} \end{aligned}$$

5. **PLAN** If $S : ax^2 + 2hxy + by^2 + 2gx + 2fy + C$ then equation of chord bisected at $P(x_1, y_1)$ is $T = S_1$
 or $axx_1 + h(xy_1 + yx_1) + byy_1 + g(x + x_1) + f(y + y_1) + C = ax_1^2 + 2hx_1y_1 + by_1^2 + 2gx_1 + 2fy_1 + C$

Description of Situation As equation of chord of contact is $T = 0$

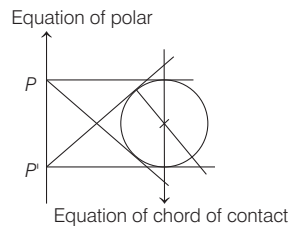

Here, equation of chord of contact w.r.t. P is

$$\begin{aligned} x\lambda + y \left(\frac{4\lambda - 20}{5} \right) &= 9 \\ 5\lambda x + (4\lambda - 20)y &= 45 \end{aligned} \quad \dots(i)$$

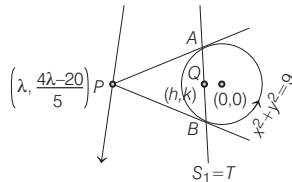

and equation of chord bisected at the point $Q(h, k)$ is

$$\begin{aligned} xh + yk - 9 &= h^2 + k^2 - 9 \\ \Rightarrow xh + yk &= h^2 + k^2 \end{aligned} \quad \dots(ii)$$

From Eqs. (i) and (ii), we get

$$\begin{aligned} \frac{5\lambda}{h} &= \frac{4\lambda - 20}{k} = \frac{45}{h^2 + k^2} \\ \therefore \lambda &= \frac{20h}{4h - 5k} \text{ and } \lambda = \frac{9h}{h^2 + k^2} \\ \Rightarrow \frac{20h}{4h - 5k} &= \frac{9h}{h^2 + k^2} \\ \text{or } 20(h^2 + k^2) &= 9(4h - 5k) \\ \text{or } 20(x^2 + y^2) &= 36x - 45y \end{aligned}$$

6. For required circle, $P(1, 8)$ and $O(3, 2)$ will be the end point of its diameter.
 $\therefore (x - 1)(x - 3) + (y - 8)(y - 2) = 0$
 $\Rightarrow x^2 + y^2 - 4x - 10y + 19 = 0$

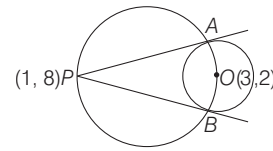

7. We have to find locus of mid-point of chord and we know perpendicular from centre bisects the chord.
 $\therefore \angle OAC = 45^\circ$

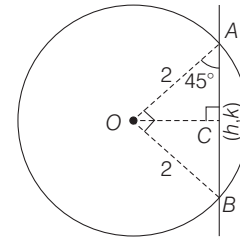

In ΔOAC , $\frac{OC}{OA} = \sin 45^\circ \Rightarrow OC = \frac{2}{\sqrt{2}} = \sqrt{2}$

Also, $\sqrt{h^2 + k^2} = OC^2$

Hence, $x^2 + y^2 = 2$ is required equation of locus of mid-point of chord subtending right angle at the centre.

8. Since, tangents are drawn from origin. So, the equation of tangent be $y = mx$.
 \Rightarrow Length of perpendicular from origin = radius

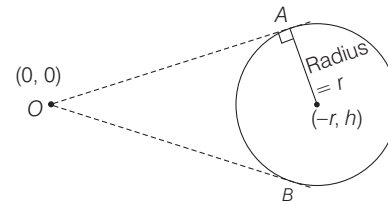

$$\begin{aligned} \Rightarrow \frac{|mr + h|}{\sqrt{m^2 + 1}} &= r \\ \Rightarrow m^2 r^2 + h^2 + 2mrh &= r^2 (m^2 + 1) \\ \Rightarrow m &= \left| \frac{r^2 - h^2}{2rh} \right|, m = \infty \\ \therefore \text{Equation of tangents are } y &= \left| \frac{r^2 - h^2}{2rh} \right| x, x = 0 \end{aligned}$$

Therefore (a) and (c) are the correct answers.

9. Equation of given circle C is $(x - 3)^2 + (y + 5)^2 = 9 + 25 - 30$
 i.e. $(x - 3)^2 + (y + 5)^2 = 2^2$
 Centre = $(3, -5)$
 If L_1 is diameter, then $2(3) + 3(-5) + p - 3 = 0 \Rightarrow p = 12$
 $\therefore L_1$ is $2x + 3y + 9 = 0$
 L_2 is $2x + 3y + 15 = 0$

Distance of centre of circle from L_2 equals

$$\left| \frac{2(3) + 3(-5) + 15}{\sqrt{2^2 + 3^2}} \right| = \frac{6}{\sqrt{13}} < 2 \quad [\text{radius of circle}]$$

436 Circle

$\therefore L_2$ is a chord of circle C .

Statement II is false.

10. A point on the line $2x + y = 4$ is of the form $(h, 4 - 2h)$.

Equation of the chord of contact is $T = 0$ i.e.

$$hx + (4 - 2h)y = 1 \Rightarrow (4y - 1) + h(x - 2y) = 0$$

This line passes through the point of intersection of $4y - 1 = 0$ and $x - 2y = 0$ i.e. through the point $\left(\frac{1}{2}, \frac{1}{4}\right)$.

11. Given, $4x^2 + 4y^2 - 12x + 4y + 1 = 0$

$$\Rightarrow x^2 + y^2 - 3x + y + 1/4 = 0$$

whose centre is $\left(\frac{3}{2}, -\frac{1}{2}\right)$ and radius

$$= \sqrt{\left(\frac{3}{2}\right)^2 + \left(-\frac{1}{2}\right)^2} - \frac{1}{4} = \sqrt{\frac{9}{4} + \frac{1}{4}} - \frac{1}{4} = \frac{3}{2}$$

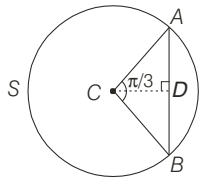

Again, let S be a circle with centre at C and AB is given chord and AD subtend angle $2\pi/3$ at the centre and D be the mid point of AB and let its coordinates are (h, k) .

$$\text{Now, } \angle DCA = \frac{1}{2}(\angle BCA) = \frac{1}{2} \cdot \frac{2\pi}{3} = \frac{\pi}{3}$$

Using sine rule in $\triangle ADC$,

$$\frac{DA}{\sin \pi/3} = \frac{CA}{\sin \pi/2}$$

$$\Rightarrow DA = CA \sin \pi/3 = \frac{3}{2} \cdot \frac{\sqrt{3}}{2}$$

Now, in $\triangle ACD$

$$CD^2 = CA^2 - AD^2 = \frac{9}{4} - \frac{27}{16} = \frac{9}{16}$$

$$\text{But } CD^2 = (h - 3/2)^2 + (k + 1/2)^2$$

$$\Rightarrow (h - 3/2)^2 + (k + 1/2)^2 = \frac{9}{16}$$

Hence, locus of a point is

$$\left(x - \frac{3}{2}\right)^2 + \left(y + \frac{1}{2}\right)^2 = \frac{9}{16}$$

$$\Rightarrow 16x^2 + 16y^2 - 48x + 16y + 31 = 0$$

12. Area of triangle formed by the tangents from the point (h, k) to the circle $x^2 + y^2 = a^2$ and their chord of contact

$$= a \frac{(h^2 + k^2 - a^2)^{3/2}}{h^2 + k^2}$$

Thus, area of triangle formed by tangents from $(4, 3)$ to the circle $x^2 + y^2 = 9$ and their chord of contact

$$\begin{aligned} &= \frac{3(4^2 + 3^2 - 9)^{3/2}}{4^2 + 3^2} = \frac{3(16 + 9 - 9)^{3/2}}{25} \\ &= \frac{3(64)}{25} = \frac{192}{25} \text{ sq units} \end{aligned}$$

13. Given, $(x + 2)^2 + (y - 3)^2 = 4$

Let the coordinate be $M(h, k)$, where B is mid-point of A and M .

$$\Rightarrow B\left(\frac{h}{2}, \frac{k+3}{2}\right)$$

But AB is the chord of circle

$$x^2 + 4x + (y - 3)^2 = 0$$

Thus, B must satisfy above equation.

$$\therefore \frac{h^2}{4} + \frac{4h}{2} + \left[\frac{1}{2}(k+3) - 3\right]^2 = 0$$

$$\Rightarrow h^2 + k^2 + 8h - 6k + 9 = 0$$

\therefore Locus of M is the circle

$$x^2 + y^2 + 8x - 6y + 9 = 0$$

14. Equation of straight line passing through intersection of two circles C_1 and C_2 is $(S_1 - S_2) = 0$.

$$\therefore x^2 + y^2 - \frac{2}{3}x + 4y - 3 - (x^2 + y^2 + 6x + 2y - 15) = 0$$

$$\Rightarrow \frac{20}{3}x - 2y - 12 = 0 \Rightarrow 10x - 3y - 18 = 0$$

15. Here, length of tangent AB

$$= \sqrt{4^2 + 5^2 - 4(4) - 2(5) - 11} = 2$$

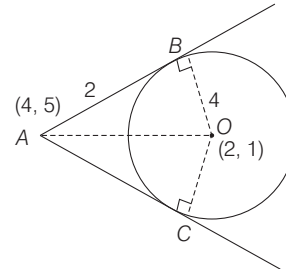

\therefore Area of quadrilateral $ABOC = 2$ area of $\triangle ABO$

$$= 2 \cdot \frac{1}{2} (AB)(OB) = 2 \cdot 4 = 8 \text{ sq units}$$

16. For the equation of circle $x^2 + y^2 - 2x = 0$. Let the mid-point of chords be (h, k) .

\therefore Equation of chord bisected at the point is $S_1 = T$.

$\therefore h^2 + k^2 - 2h = xh + yk - (x + h)$ which passes through $(0, 0)$.

$$\Rightarrow h^2 + k^2 - 2h = -h$$

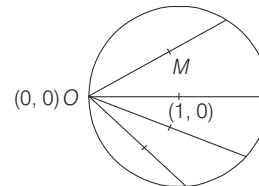

\therefore The required locus of a chord is $x^2 + y^2 - x = 0$

- 17.

$$2x^2 + y^2 - 3xy = 0 \quad [\text{given}]$$

$$\Rightarrow 2x^2 - 2xy - xy + y^2 = 0$$

$$\Rightarrow 2x(x - y) - y(x - y) = 0$$

$$\Rightarrow (2x - y)(x - y) = 0$$

$$\Rightarrow y = 2x, y = x$$

are the equations of straight lines passing through origin.

Now, let the angle between the lines be 2θ and the line $y = x$ makes angle of 45° with X -axis.

Therefore, $\tan(45^\circ + 2\theta) = 2$ (slope of the line $y = 2x$)

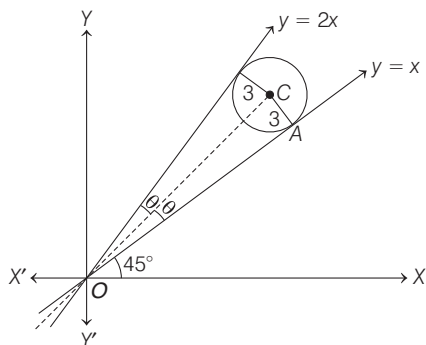

$$\begin{aligned} \Rightarrow \frac{\tan 45^\circ + \tan 2\theta}{1 - \tan 45^\circ \times \tan 2\theta} &= 2 \Rightarrow \frac{1 + \tan 2\theta}{1 - \tan 2\theta} = 2 \\ \Rightarrow \frac{(1 + \tan 2\theta) - (1 - \tan 2\theta)}{(1 + \tan 2\theta) + (1 - \tan 2\theta)} &= \frac{2 - 1}{2 + 1} = \frac{1}{3} \\ \Rightarrow \frac{2 \tan 2\theta}{2} = \frac{1}{3} \Rightarrow \tan 2\theta &= \frac{1}{3} \Rightarrow \frac{2 \tan \theta}{1 - \tan^2 \theta} = \frac{1}{3} \\ \Rightarrow (2 \tan \theta) \cdot 3 &= 1 - \tan^2 \theta \\ \Rightarrow \tan^2 \theta + 6 \tan \theta - 1 &= 0 \\ \Rightarrow \tan \theta &= \frac{-6 \pm \sqrt{36 + 4 \times 1 \times 1}}{2} = \frac{-6 \pm \sqrt{40}}{2} \\ \Rightarrow \tan \theta &= -3 \pm \sqrt{10} \\ \Rightarrow \tan \theta &= -3 + \sqrt{10} \quad \left[\because 0 < \theta < \frac{\pi}{4} \right] \end{aligned}$$

Again, in ΔOCA

$$\begin{aligned} \tan \theta &= \frac{3}{OA} \\ \therefore OA &= \frac{3}{\tan \theta} = \frac{3}{-3 + \sqrt{10}} = \frac{3(3 + \sqrt{10})}{(-3 + \sqrt{10})(3 + \sqrt{10})} \\ &= \frac{3(3 + \sqrt{10})}{(10 - 9)} = 3(3 + \sqrt{10}) \end{aligned}$$

18.

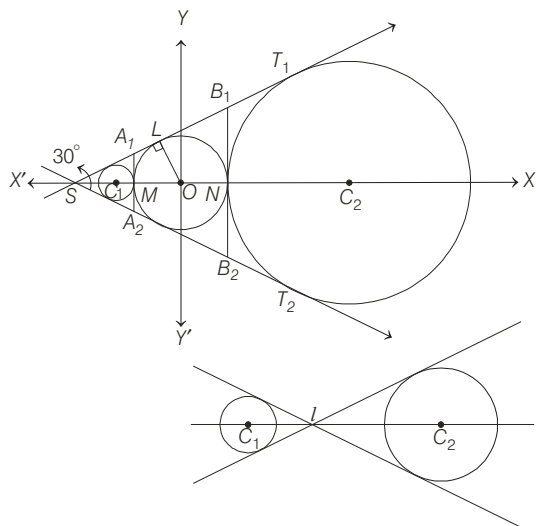

From figure it is clear that, ΔOLS is a right triangle with right angle at L .

Also, $OL = 1$ and $OS = 2$

$$\therefore 1 \sin(\angle LSO) = \frac{1}{2} \Rightarrow \angle LSO = 30^\circ$$

Since, $SA_1 = SA_2$, ΔSA_1A_2 is an equilateral triangle.

The circle with centre at C_1 is a circle inscribed in the ΔSA_1A_2 . Therefore, centre C_1 is centroid of ΔSA_1A_2 . This, C_1 divides SM in the ratio $2 : 1$. Therefore, coordinates of C_1 are $(-4/3, 0)$ and its radius $= C_1M = 1/3$

$$\therefore \text{Its equation is } (x + 4/3)^2 + y^2 = (1/3)^2 \quad \dots(i)$$

The other circle touches the equilateral triangle SB_1B_2 externally. Its radius r is given by $r = \frac{\Delta}{s - a}$,

$$\text{where } B_1B_2 = a. \text{ But } \Delta = \frac{1}{2}(a)(SN) = \frac{3}{2}a$$

$$\text{and } s - a = \frac{3}{2}a - a = \frac{a}{2}$$

Thus, $r = 3$

\Rightarrow Coordinates of C_2 are $(4, 0)$.

$$\therefore \text{Equation of circle with centre at } C_2 \text{ is } (x - 4)^2 + y^2 = 3^2 \quad \dots(ii)$$

Equations of common tangents to circle (i) and circle C are

$$x = -1 \text{ and } y = \pm \frac{1}{\sqrt{3}}(x + 2) \quad [T_1 \text{ and } T_2]$$

Equation of common tangents to circle (ii) and circle C are

$$x = 1 \text{ and } y = \pm \frac{1}{\sqrt{3}}(x + 2) \quad [T_1 \text{ and } T_2]$$

Two tangents common to (i) and (ii) are T_1 and T_2 at O . To find the remaining two transverse tangents to (i) and (ii), we find a point I which divides the joint of C_1C_2 in the ratio $r_1 : r_2 = 1/3 : 3 = 1 : 9$

Therefore, coordinates of I are $(-4/5, 0)$

Equation of any line through I is $y = m(x + 4/5)$. It will touch (i) if

$$\left| \frac{m\left(\frac{-4}{3} + \frac{4}{5}\right) - 0}{\sqrt{1 + m^2}} \right| = \frac{1}{3} \Rightarrow \left| \frac{8m}{15} \right| = \frac{1}{3} \sqrt{1 + m^2}$$

$$\Rightarrow 64m^2 = 25(1 + m^2)$$

$$\Rightarrow 39m^2 = 25$$

$$\Rightarrow m = \pm \frac{5}{\sqrt{39}}$$

Therefore, these tangents are $y = \pm \frac{5}{\sqrt{39}}\left(x + \frac{4}{5}\right)$

19. Let the coordinate of point P be $(2r \cos \theta, 2r \sin \theta)$

We have, $OA = r, OP = 2r$

Since, ΔOAP is a right angled triangle.

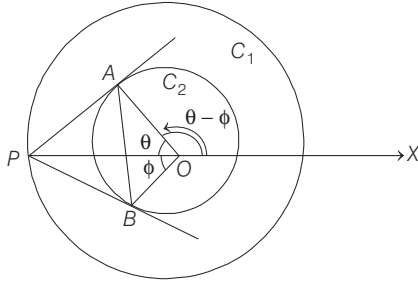

$$\cos \phi = 1/2 \Rightarrow \phi = \pi/3$$

∴ Coordinates of A are $\{r \cos (\theta - \pi/3), r \sin (\theta - \pi/3)\}$ and that of B are $\{r \cos (\theta + \pi/3), r \sin (\theta + \pi/3)\}$

If p, q is the centroid of ΔPAB , then

$$p = \frac{1}{3} [r \cos (\theta - \pi/3) + r \cos (\theta + \pi/3) + 2r \cos \theta]$$

$$= \frac{1}{3} [r \{\cos (\theta - \pi/3) + \cos (\theta + \pi/3)\} + 2r \cos \theta]$$

$$= \frac{1}{3} \left[r \left(2 \cos \frac{\theta - \frac{\pi}{3} + \theta + \frac{\pi}{3}}{2} \cdot \cos \frac{\theta - \frac{\pi}{3} - \theta - \frac{\pi}{3}}{2} \right) + 2r \cos \theta \right]$$

$$= \frac{1}{3} [r \{2 \cos \theta \cos \pi/3\} + 2r \cos \theta]$$

$$= \frac{1}{3} [r \cdot \cos \theta + 2r \cos \theta] = r \cos \theta$$

and $q = \frac{1}{3} [r \sin (\theta - \frac{\pi}{3}) + r \sin (\theta + \frac{\pi}{3}) + 2r \sin \theta]$

$$= \frac{1}{3} [r \{\sin (\theta - \frac{\pi}{3}) + \sin (\theta + \frac{\pi}{3})\} + 2r \sin \theta]$$

$$= \frac{1}{3} \left[r \left(2 \sin \frac{\theta - \frac{\pi}{3} + \theta + \frac{\pi}{3}}{2} \cdot \cos \frac{\theta - \frac{\pi}{3} - \theta - \frac{\pi}{3}}{2} \right) + 2r \sin \theta \right]$$

$$= \frac{1}{3} [r (2 \sin \theta \cos \pi/3) + 2r \sin \theta]$$

$$= \frac{1}{3} [r (\sin \theta) + 2r \sin \theta] = r \sin \theta$$

Now, $(p, q) = (r \cos \theta, r \sin \theta)$ lies on $x^2 + y^2 = r^2$ which is called C_1 .

20. Given, $2x^2 + 2y^2 - (1 + \sqrt{2}a)x - (1 - \sqrt{2}a)y = 0$

$$\Rightarrow x^2 + y^2 - \left(\frac{1 + \sqrt{2}a}{2}\right)x - \left(\frac{1 - \sqrt{2}a}{2}\right)y = 0$$

Since, $y + x = 0$ bisects two chords of this circle, mid points of the chords must be of the form $(\alpha, -\alpha)$.

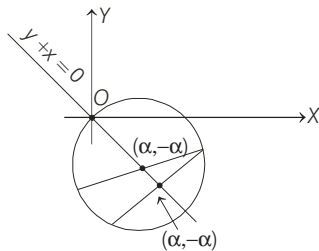

Equation of the chord having $(\alpha, -\alpha)$ as mid points is

$$T = S_1$$

$$\Rightarrow x\alpha + y(-\alpha) - \left(\frac{1 + \sqrt{2}a}{4}\right)(x + \alpha) - \left(\frac{1 - \sqrt{2}a}{4}\right)(y - \alpha)$$

$$= \alpha^2 + (-\alpha)^2 - \left(\frac{1 + \sqrt{2}a}{2}\right)\alpha - \left(\frac{1 - \sqrt{2}a}{2}\right)(-\alpha)$$

$$\Rightarrow 4x\alpha - 4y\alpha - (1 + \sqrt{2}a)x - (1 + \sqrt{2}a)\alpha$$

$$- (1 - \sqrt{2}a)y + (1 - \sqrt{2}a)\alpha$$

$$= 4\alpha^2 + 4\alpha^2 - (1 + \sqrt{2}a) \cdot 2\alpha + (1 - \sqrt{2}a) \cdot 2\alpha$$

$$\Rightarrow 4\alpha x - 4\alpha y - (1 + \sqrt{2}a)x - (1 - \sqrt{2}a)y$$

$$= 8\alpha^2 - (1 + \sqrt{2}a)\alpha + (1 - \sqrt{2}a)\alpha$$

But this chord will pass through the point

$$\left(\frac{1 + \sqrt{2}a}{2}, \frac{1 - \sqrt{2}a}{2}\right)$$

$$4\alpha \left(\frac{1 + \sqrt{2}a}{2}\right) - 4\alpha \left(\frac{1 - \sqrt{2}a}{2}\right) - \frac{(1 + \sqrt{2}a)(1 + \sqrt{2}a)}{2}$$

$$- \frac{(1 - \sqrt{2}a)(1 - \sqrt{2}a)}{2}$$

$$= 8\alpha^2 - 2\sqrt{2}\alpha\alpha$$

$$\Rightarrow 2\alpha [(1 + \sqrt{2}a - 1 + \sqrt{2}a)] = 8\alpha^2 - 2\sqrt{2}\alpha\alpha$$

$$\Rightarrow 4\sqrt{2}\alpha\alpha - \frac{1}{2}[2 + 2(\sqrt{2}a)^2] = 8\alpha^2 - 2\sqrt{2}\alpha\alpha$$

$$[\because (a + b)^2 + (a - b)^2 = 2a^2 + 2b^2]$$

$$\Rightarrow 8\alpha^2 - 6\sqrt{2}\alpha\alpha + 1 + 2a^2 = 0$$

But this quadratic equation will have two distinct roots, if

$$(6\sqrt{2}a)^2 - 4(8)(1 + 2a^2) > 0 \Rightarrow 72a^2 - 32(1 + 2a^2) > 0$$

$$\Rightarrow 8a^2 - 32 > 0 \Rightarrow a^2 - 4 > 0 \Rightarrow a < -2 \cup a > 2$$

Therefore, $a \in (-\infty, -2) \cup (2, \infty)$.

21. The given circle can be rewritten as

$$x^2 + y^2 - ax - \frac{by}{2} = 0 \quad \dots(i)$$

Let one of the chord through $(a, b/2)$ be bisected at $(h, 0)$.

Then, the equation of the chord having $(h, 0)$ as mid-point is

$$T = S_1$$

$$\Rightarrow h \cdot x + 0 \cdot y - \frac{a}{2}(x + h) - \frac{b}{4}(y + 0) = h^2 + 0 - ah - 0$$

$$\Rightarrow \left(h - \frac{a}{2}\right)x - \frac{by}{4} - \frac{a}{2}h = h^2 - ah \quad \dots(ii)$$

It passes through $(a, b/2)$, then

$$\left(h - \frac{a}{2}\right)a - \frac{b}{4} \cdot \frac{b}{2} - \frac{a}{2}h = h^2 - ah$$

$$\Rightarrow h^2 - \frac{3}{2}ah + \frac{a^2}{2} + \frac{b^2}{8} = 0 \quad \dots(iii)$$

According to the given condition, Eq. (iii) must have two distinct real roots. This is possible, if the discriminant of Eq. (iii) is greater than 0.

i.e. $\frac{9}{4} a^2 - 4 \left(\frac{a^2}{2} + \frac{b^2}{8} \right) > 0 \Rightarrow \frac{a^2}{4} - \frac{b^2}{2} > 0$
 $\Rightarrow a^2 > 2b^2$

22. Since, $5x + 12y - 10 = 0$ and $5x - 12y - 40 = 0$ are both perpendicular tangents to the circle C_1 .

$\therefore OABC$ forms a square.

Let the centre coordinates be (h, k) , where,

$OC = OA = 3$ and $OB = 6\sqrt{2}$
 $\Rightarrow \frac{|5h + 12k - 10|}{13} = 3$ and $\frac{|5h + 12k - 40|}{13} = 3$

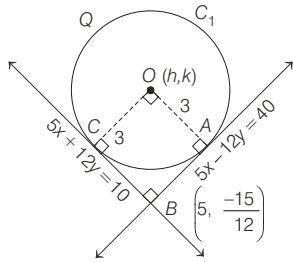

$\Rightarrow 5h + 12k - 10 = \pm 39$ and $5h - 12k - 40 = \pm 39$
 on solving above equations. The coordinates which lie in I quadrant are $(5, 2)$.

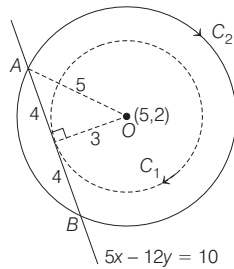

\therefore Centre for C_1 $(5, 2)$

To obtain equation of circle concentric with C_1 and making an intercept of length 8 on $5x + 12y = 10$ and $5x - 12y = 40$

\therefore Required equation of circle C_2 has centre $(5, 2)$ and radius 5 is $(x - 5)^2 + (y - 2)^2 = 5^2$

23. Given, circle is $x^2 + y^2 = r^2$

Equation of chord whose mid point is given, is

$T = S_1 \Rightarrow xx_1 + yy_1 - r^2 = x_1^2 + y_1^2 - r^2$

It also passes through (h, k) $hx_1 + ky_1 = x_1^2 + y_1^2$

\therefore Locus of (x_1, y_1) is

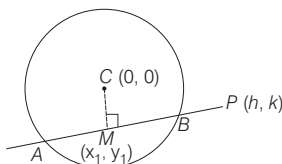

$x^2 + y^2 = hx + ky$

Alternate Solution

Let M be the mid-point of chord AB .

$\Rightarrow CM \perp MP$

\Rightarrow (slope of CM) \cdot (slope of MP) = -1

$\Rightarrow \frac{y_1}{x_1} \cdot \frac{k - y_1}{h - x_1} = -1 \Rightarrow ky_1 - y_1^2 = -hx_1 + x_1^2$

Hence, required locus is $x^2 + y^2 = hx + ky$

24. Equation of tangents at $(1, 7)$ and $(4, -2)$ are

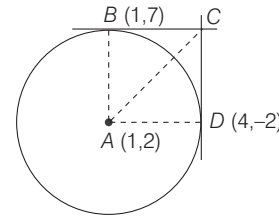

$x + 7y - (x + 1) - 2(y + 7) - 20 = 0$
 $\Rightarrow 5y = 35 \Rightarrow y = 7$
 and $4x - 2y - (x + 4) - 2(y - 2) - 20 = 0$
 $\Rightarrow 3x - 4y = 20$

\therefore Point C is $(16, 7)$.

\therefore Vertices of a quadrilateral are

$A(1, 2), B(1, 7), C(16, 7), D(4, -2)$

\therefore Area of quadrilateral $ABCD$

= Area of ΔABC + Area of ΔACD
 $= \frac{1}{2} \times 15 \times 5 + \frac{1}{2} \times 15 \times 5 = 75$ sq units

25. As we know that the equation of family of circles passes through the points of intersection of given circle $x^2 + y^2 = r^2$ and line $PQ : 2x + 4y = 5$ is,

$(x^2 + y^2 - r^2) + \lambda(2x + 4y - 5) = 0$... (i)

Since, the circle (i) passes through the centre of circle

$x^2 + y^2 = r^2,$

So, $-r^2 - 5\lambda = 0 \Rightarrow 5\lambda + r^2 = 0$... (ii)

and the centre of circle (i) lies on the line $x + 2y = 4$, so centre $(-\lambda, -2\lambda)$ satisfy the line $x + 2y = 4$.

Therefore, $-\lambda - 4\lambda = 4$

$\Rightarrow -5\lambda = 4 \Rightarrow r^2 = 4$ {from Eq. (ii)}

$\Rightarrow r = 2$

26. Let $\theta = \frac{\pi}{2k} \Rightarrow \cos \theta = \frac{x}{2}$

$\Rightarrow \cos 2\theta = \frac{\sqrt{3} + 1 - x}{2}$

$\Rightarrow 2 \cos^2 \theta - 1 = \frac{\sqrt{3} + 1 - x}{2}$

$\Rightarrow 2 \left(\frac{x^2}{4} \right) - 1 = \frac{\sqrt{3} + 1 - x}{2}$

$\Rightarrow x^2 + x - 3 - \sqrt{3} = 0 \Rightarrow x = \frac{-1 \pm \sqrt{1 + 12 + 4\sqrt{3}}}{2}$

$= \frac{-1 \pm \sqrt{13 + 4\sqrt{3}}}{2} = \frac{-1 + 2\sqrt{3} + 1}{2} = \sqrt{3}$

$\therefore \cos \theta = \frac{\sqrt{3}}{2} \Rightarrow \theta = \frac{\pi}{6}$

\therefore Required angle = $\frac{\pi}{k} = 2\theta = \frac{\pi}{3} \Rightarrow k = 3$

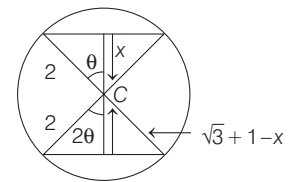

17

Parabola

Topic 1 Equation of Parabola and Focal Chord

Objective Questions I (Only one correct option)

- The locus of a point which divides the line segment joining the point $(0, -1)$ and a point on the parabola, $x^2 = 4y$, internally in the ratio $1 : 2$, is (2020 Main, 8 Jan I)
(a) $4x^2 - 3y = 2$ (b) $x^2 - 3y = 2$
(c) $9x^2 - 12y = 8$ (d) $9x^2 - 3y = 2$
- If the area of the triangle whose one vertex is at the vertex of the parabola, $y^2 + 4(x - a^2) = 0$ and the other two vertices are the points of intersection of the parabola and Y -axis, is 250 sq units, then a value of ' a ' is (2019 Main, 11 Jan, II)
(a) $5\sqrt{5}$ (b) 5 (c) $5(2^{1/3})$ (d) $(10)^{2/3}$
- A circle cuts a chord of length $4a$ on the X -axis and passes through a point on the Y -axis, distant $2b$ from the origin. Then, the locus of the centre of this circle, is (2019 Main, 11 Jan, II)
(a) a parabola (b) an ellipse
(c) a straight line (d) a hyperbola
- Axis of a parabola lies along X -axis. If its vertex and focus are at distances 2 and 4 respectively from the origin, on the positive X -axis, then which of the following points does not lie on it? (2019 Main, 9 Jan, I)
(a) $(4, -4)$ (b) $(6, 4\sqrt{2})$ (c) $(8, 6)$ (d) $(5, 2\sqrt{6})$
- Let P be the point on the parabola, $y^2 = 8x$, which is at a minimum distance from the centre C of the circle, $x^2 + (y + 6)^2 = 1$. Then, the equation of the circle, passing through C and having its centre at P is (2016 Main)
(a) $x^2 + y^2 - 4x + 8y + 12 = 0$
(b) $x^2 + y^2 - x + 4y - 12 = 0$
(c) $x^2 + y^2 - \frac{x}{4} + 2y - 24 = 0$
(d) $x^2 + y^2 - 4x + 9y + 18 = 0$
- Let O be the vertex and Q be any point on the parabola $x^2 = 8y$. If the point P divides the line segment OQ internally in the ratio $1 : 3$, then the locus of P is (2015)
(a) $x^2 = y$ (b) $y^2 = x$ (c) $y^2 = 2x$ (d) $x^2 = 2y$
- Let (x, y) be any point on the parabola $y^2 = 4x$. Let P be the point that divides the line segment from $(0, 0)$ to (x, y) in the ratio $1 : 3$. Then, the locus of P is (2011)
(a) $x^2 = y$ (b) $y^2 = 2x$
(c) $y^2 = x$ (d) $x^2 = 2y$
- Axis of a parabola is $y = x$ and vertex and focus are at a distance $\sqrt{2}$ and $2\sqrt{2}$ respectively from the origin. Then, equation of the parabola is (2006, 3M)
(a) $(x - y)^2 = 8(x + y - 2)$
(b) $(x + y)^2 = 2(x + y - 2)$
(c) $(x - y)^2 = 4(x + y - 2)$
(d) $(x + y)^2 = 2(x - y + 2)$
- The locus of the mid-point of the line segment joining the focus to a moving point on the parabola $y^2 = 4ax$ is another parabola with directrix (2002, 1M)
(a) $x = -a$ (b) $x = -\frac{a}{2}$
(c) $x = 0$ (d) $x = \frac{a}{2}$
- The equation of the directrix of the parabola $y^2 + 4y + 4x + 2 = 0$ is (2001, 1M)
(a) $x = -1$ (b) $x = 1$
(c) $x = -3/2$ (d) $x = 3/2$
- If the line $x - 1 = 0$ is the directrix of the parabola $y^2 - kx + 8 = 0$, then one of the values of k is (2000, 2M)
(a) $\frac{1}{8}$ (b) 8
(c) 4 (d) $\frac{1}{4}$
- The curve described parametrically by $x = t^2 + t + 1, y = t^2 - t + 1$ represents (1999, 2M)
(a) a pair of straight lines (b) an ellipse
(c) a parabola (d) a hyperbola

Assertion and Reason

13. **Statement I** The curve $y = -\frac{x^2}{2} + x + 1$ is symmetric with respect to the line $x = 1$, because (2007, 3M)
- Statement II** A parabola is symmetric about its axis.
- (a) Statement I is correct, Statement II is correct, Statement II is a correct explanation for Statement I
 (b) Statement I is correct, Statement II is correct, Statement II is not a correct explanation for Statement I
 (c) Statement I is correct, Statement II is incorrect
 (d) Statement I is incorrect, Statement II is correct

Topic 2 Equation of Tangents and Properties

Objective Questions I (Only one correct option)

1. Let L_1 be a tangent to the parabola $y^2 = 4(x + 1)$ and L_2 be a tangent to the parabola $y^2 = 8(x + 2)$ such that L_1 and L_2 intersect at right angles. Then, L_1 and L_2 meet on the straight line (2020 Main, 6 Sep I)
- (a) $x + 3 = 0$ (b) $2x + 1 = 0$
 (c) $x + 2 = 0$ (d) $x + 2y = 0$
2. If the line $ax + y = c$, touches both the curves $x^2 + y^2 = 1$ and $y^2 = 4\sqrt{2}x$, then $|c|$ is equal to (2019 Main, 10 April, II)
- (a) $\frac{1}{\sqrt{2}}$ (b) 2 (c) $\sqrt{2}$ (d) $\frac{1}{2}$
3. The tangents to the curve $y = (x - 2)^2 - 1$ at its points of intersection with the line $x - y = 3$, intersect at the point (2019 Main, 12 April II)
- (a) $\left(\frac{5}{2}, 1\right)$ (b) $\left(-\frac{5}{2}, -1\right)$ (c) $\left(\frac{5}{2}, -1\right)$ (d) $\left(-\frac{5}{2}, 1\right)$
4. The area (in sq units) of the smaller of the two circles that touch the parabola, $y^2 = 4x$ at the point $(1, 2)$ and the X -axis is (2019 Main, 9 April, II)
- (a) $8\pi(3 - 2\sqrt{2})$ (b) $4\pi(3 + \sqrt{2})$
 (c) $8\pi(2 - \sqrt{2})$ (d) $4\pi(2 - \sqrt{2})$
5. The equation of a tangent to the parabola, $x^2 = 8y$, which makes an angle θ with the positive direction of X -axis, is (2019 Main, 12 Jan, II)
- (a) $y = x \tan \theta - 2 \cot \theta$ (b) $x = y \cot \theta + 2 \tan \theta$
 (c) $y = x \tan \theta + 2 \cot \theta$ (d) $x = y \cot \theta - 2 \tan \theta$
6. Equation of a common tangent to the circle, $x^2 + y^2 - 6x = 0$ and the parabola, $y^2 = 4x$, is (2019 Main, 9 Jan, I)
- (a) $\sqrt{3}y = 3x + 1$ (b) $2\sqrt{3}y = 12x + 1$
 (c) $\sqrt{3}y = x + 3$ (d) $2\sqrt{3}y = -x - 12$
7. Tangent and normal are drawn at $P(16, 16)$ on the parabola $y^2 = 16x$, which intersect the axis of the

Integer & Numerical Answer Type Questions

14. Let the curve C be the mirror image of the parabola $y^2 = 4x$ with respect to the line $x + y + 4 = 0$. If A and B are the points of intersection of C with the line $y = -5$, then the distance between A and B is (2015 Adv.)
15. Let S be the focus of the parabola $y^2 = 8x$ and PQ be the common chord of the circle $x^2 + y^2 - 2x - 4y = 0$ and the given parabola. The area of ΔPQS is (2012)

parabola at A and B , respectively. If C is the centre of the circle through the points P , A and B and $\angle CPB = \theta$, then a value of $\tan \theta$ is (2018 Main)

- (a) $\frac{1}{2}$ (b) 2 (c) 3 (d) $\frac{4}{3}$
8. The radius of a circle having minimum area, which touches the curve $y = 4 - x^2$ and the lines $y = |x|$, is (2017 Main)
- (a) $2(\sqrt{2} + 1)$ (b) $2(\sqrt{2} - 1)$
 (c) $4(\sqrt{2} - 1)$ (d) $4(\sqrt{2} + 1)$
9. The slope of the line touching both the parabolas $y^2 = 4x$ and $x^2 = -32y$ is (2014 Main)
- (a) $\frac{1}{2}$ (b) $\frac{3}{2}$ (c) $\frac{1}{8}$ (d) $\frac{2}{3}$
10. The tangent at $(1, 7)$ to the curves $x^2 = y - 6x$ touches the circle $x^2 + y^2 + 16x + 12y + c = 0$ at (2005 2M)
- (a) $(6, 7)$ (b) $(-6, 7)$ (c) $(6, -7)$ (d) $(-6, -7)$
11. The angle between the tangents drawn from the point $(1, 4)$ to the parabola $y^2 = 4x$ is (2004, 1M)
- (a) $\frac{\pi}{6}$ (b) $\frac{\pi}{4}$ (c) $\frac{\pi}{3}$ (d) $\frac{\pi}{2}$
12. The focal chord to $y^2 = 16x$ is tangent to $(x - 6)^2 + y^2 = 2$, then the possible values of the slope of this chord are (2003, 1M)
- (a) $\{-1, 1\}$ (b) $\{-2, 2\}$
 (c) $\{-2, 1/2\}$ (d) $\{2, -1/2\}$
13. The equation of the common tangent to the curves $y^2 = 8x$ and $xy = -1$ is (2002, 1M)
- (a) $3y = 9x + 2$ (b) $y = 2x + 1$
 (c) $2y = x + 8$ (d) $y = x + 2$
14. The equation of the common tangent touching the circle $(x - 3)^2 + y^2 = 9$ and the parabola $y^2 = 4x$ above the X -axis is (2001, 1M)
- (a) $\sqrt{3}y = 3x + 1$ (b) $\sqrt{3}y = -(x + 3)$

442 Parabola

(c) $\sqrt{3}y = x + 3$ (d) $\sqrt{3}y = -(3x + 1)$

Assertion and Reason

15. Given A circle, $2x^2 + 2y^2 = 5$ and a parabola, $y^2 = 4\sqrt{5}x$.

Statement I An equation of a common tangent to these curves is $y = x + \sqrt{5}$.

Statement II If the line, $y = mx + \frac{\sqrt{5}}{m}$ ($m \neq 0$) is the common tangent, then m satisfies $m^4 - 3m^2 + 2 = 0$.

(2013 Main)

- (a) Statement I is correct, Statement II is correct, Statement II is a correct explanation for Statement I
 (b) Statement I is correct, Statement II is correct, Statement II is not a correct explanation for Statement I
 (c) Statement I is correct, Statement II is incorrect
 (d) Statement I is incorrect, Statement II is correct

Objective Questions II

(One or more than correct option)

16. Equation of common tangent of $y = x^2$, $y = -x^2 + 4x - 4$ is (2006, 5M)
 (a) $y = 4(x - 1)$
 (b) $y = 0$
 (c) $y = -4(x - 1)$
 (d) $y = -30x - 50$

Passage Based Problems

Passage

Let a, r, s, t be non-zero real numbers. Let $P(at^2, 2at), Q, R(ar^2, 2ar)$ and $S(as^2, 2as)$ be distinct point on the parabola $y^2 = 4ax$. Suppose that PQ is the focal chord and lines QR and PK are parallel, where K is point $(2a, 0)$. (2014, Adv.)

Topic 3 Equation of Normal and Properties

Objective Questions I (Only one correct option)

1. If the parabolas $y^2 = 4b(x - c)$ and $y^2 = 8ax$ have a common normal, then which one of the following is a valid choice for the ordered triad (a, b, c) ? (2019 Main, 10 Jan I)
 (a) $(\frac{1}{2}, 2, 0)$ (b) $(1, 1, 0)$
 (c) $(1, 1, 3)$ (d) $(\frac{1}{2}, 2, 3)$
2. If $x + y = k$ is normal to $y^2 = 12x$, then k is (2000, 2M)
 (a) 3
 (b) 9
 (c) -9
 (d) -3

17. The value of r is
 (a) $-\frac{1}{t}$ (b) $\frac{t^2 + 1}{t}$ (c) $\frac{1}{t}$ (d) $\frac{t^2 - 1}{t}$

18. If $st = 1$, then the tangent at P and the normal at S to the parabola meet at a point whose ordinate is
 (a) $\frac{(t^2 + 1)^2}{2t^3}$ (b) $\frac{a(t^2 + 1)^2}{2t^3}$
 (c) $\frac{a(t^2 + 1)^2}{t^3}$ (d) $\frac{a(t^2 + 2)^2}{t^3}$

Fill in the Blank

19. The point of intersection of the tangents at the ends of the latusrectum of the parabola $y^2 = 4x$ is ... (1994, 2M)

Analytical & Descriptive Questions

20. At any point P on the parabola $y^2 - 2y - 4x + 5 = 0$ a tangent is drawn which meets the directrix at Q . Find the locus of point R , which divides QP externally in the ratio $\frac{1}{2} : 1$. (2004, 4M)
21. Find the shortest distance of the point $(0, c)$ from the parabola $y = x^2$, where $0 \leq c \leq 5$. (1982, 2M)

Integer & Numerical Answer Type Question

22. Consider the parabola $y^2 = 8x$. Let Δ_1 be the area of the triangle formed by the end points of its latusrectum and the point $P(\frac{1}{2}, 2)$ on the parabola and Δ_2 be the area of the triangle formed by drawing tangents at P and at the end points of the latusrectum. Then, $\frac{\Delta_1}{\Delta_2}$ is (2011)

Match the Columns

3. Match the conditions/expressions in Column I with statement in Column II. Normals at P, Q, R are drawn to $y^2 = 4x$ which intersect at $(3, 0)$. Then,

Column I	Column II
A. Area of ΔPQR	p. 2
B. Radius of circumcircle of ΔPQR	q. $\frac{5}{2}$
C. Centroid of ΔPQR	r. $(\frac{5}{2}, 0)$
D. Circumcentre of ΔPQR	s. $(\frac{2}{3}, 0)$

Objective Questions II

(One or more than one correct option)

4. Let P be the point on the parabola $y^2 = 4x$, which is at the shortest distance from the centre S of the circle $x^2 + y^2 - 4x - 16y + 64 = 0$. Let Q be the point on the circle dividing the line segment SP internally. Then,
 (a) $SP = 2\sqrt{5}$ (2016 Adv.)
 (b) $SQ : QP = (\sqrt{5} + 1) : 2$
 (c) the x -intercept of the normal to the parabola at P is 6
 (d) the slope of the tangent to the circle at Q is $\frac{1}{2}$
5. A solution curve of the differential equation $(x^2 + xy + 4x + 2y + 4)\frac{dy}{dx} - y^2 = 0$, $x > 0$, passes through the point $(1, 3)$. Then, the solution curve
 (a) intersects $y = x + 2$ exactly at one point (2016 Adv.)
 (b) intersects $y = x + 2$ exactly at two points
 (c) intersects $y = (x + 2)^2$
 (d) does not intersect $y = (x + 3)^2$
6. Let L be a normal to the parabola $y^2 = 4x$. If L passes through the point $(9, 6)$, then L is given by (2011)
 (a) $y - x + 3 = 0$ (b) $y + 3x - 33 = 0$
 (c) $y + x - 15 = 0$ (d) $y - 2x + 12 = 0$
7. The tangent PT and the normal PN to the parabola $y^2 = 4ax$ at a point P on it meet its axis at points T and N , respectively. The locus of the centroid of the triangle PTN is a parabola, whose (2009)

- (a) vertex is $\left(\frac{2a}{3}, 0\right)$ (b) directrix is $x = 0$
 (c) latusrectum is $\frac{2a}{3}$ (d) focus is $(a, 0)$

Integer & Numerical Answer Type Question

8. If the normals of the parabola $y^2 = 4x$ drawn at the end points of its latusrectum are tangents to the circle $(x - 3)^2 + (y + 2)^2 = r^2$, then the value of r^2 is (2015 Adv.)

Analytical & Descriptive Questions

9. Normals are drawn from the point P with slopes m_1, m_2, m_3 to the parabola $y^2 = 4x$. If locus of P with $m_1 m_2 = \alpha$ is a part of the parabola itself, then find α . (2003, 4M)
10. Three normals are drawn from the point $(c, 0)$ to the curve $y^2 = x$. Show that c must be greater than $\frac{1}{2}$. One normal is always the X -axis. Find c for which the other two normals are perpendicular to each other. (1991, 4M)
11. Find the equation of the normal to the curve $x^2 = 4y$ which passes through the point $(1, 2)$. (1984, 4M)
12. Suppose that the normals drawn at three different points on the parabola $y^2 = 4x$ pass through the point $(h, 0)$. Show that $h > 2$. (1981, 4M)

Topic 4 Diameter, Chord of Contact, Chord Bisected and Product of Pair of Tangents**Objective Questions II**

(One or more than one correct option)

1. If one end of a focal chord of the parabola, $y^2 = 16x$ is at $(1, 4)$, then the length of this focal chord is (2019 Main, 9 April, I)
 (a) 22 (b) 25 (c) 24 (d) 20
2. The length of the chord of the parabola $x^2 = 4y$ having equation $x - \sqrt{2}y + 4\sqrt{2} = 0$ is (2019 Main, 10 Jan II)
 (a) $8\sqrt{2}$ (b) $2\sqrt{11}$ (c) $3\sqrt{2}$ (d) $6\sqrt{3}$
3. If a chord, which is not a tangent, of the parabola $y^2 = 16x$ has the equation $2x + y = p$, and mid-point (h, k) , then which of the following is(are) possible value(s) of p, h and k ? (2017 Adv.)
 (a) $p = -1, h = 1, k = -3$ (b) $p = 2, h = 3, k = -4$
 (c) $p = -2, h = 2, k = -4$ (d) $p = 5, h = 4, k = -3$
4. Let A and B be two distinct points on the parabola $y^2 = 4x$. If the axis of the parabola touches a circle of

radius r having AB as its diameter, then the slope of the line joining A and B can be (2010)

- (a) $-\frac{1}{r}$ (b) $\frac{1}{r}$ (c) $\frac{2}{r}$ (d) $-\frac{2}{r}$

Passage Based Problems**Passage**

Let PQ be a focal chord of the parabola $y^2 = 4ax$. The tangents to the parabola at P and Q meet at a point lying on the line $y = 2x + a, a > 0$. (2013 Adv.)

5. Length of chord PQ is
 (a) $7a$ (b) $5a$
 (c) $2a$ (d) $3a$
6. If chord PQ subtends an angle θ at the vertex of $y^2 = 4ax$, then $\tan \theta$ is equal to
 (a) $\frac{2}{3}\sqrt{7}$ (b) $\frac{-2}{3}\sqrt{7}$
 (c) $\frac{2}{3}\sqrt{5}$ (d) $\frac{-2}{3}\sqrt{5}$

444 Parabola

Analytical & Descriptive Questions

- The angle between a pair of tangents drawn from a point P to the parabola $y^2 = 4ax$ is 45° . Show that the locus of the point P is a hyperbola. (1998, 8M)
- From a point A common tangents are drawn to the circle $x^2 + y^2 = \frac{a^2}{2}$ and parabola $y^2 = 4ax$. Find the area of the quadrilateral formed by the common tangents, the chord of contact of the circle and the chord of contact of the parabola. (1996, 2M)
- Points A, B and C lie on the parabola $y^2 = 4ax$. The tangents to the parabola at A, B and C , taken in pairs, intersect at points P, Q and R . Determine the ratio of the areas of the triangles ABC and PQR . (1996, 3M)
- Show that the locus of a point that divides a chord of slope 2 of the parabola $y^2 = 4ax$ internally in the ratio 1 : 2 is a parabola. Find the vertex of this parabola. (1995, 5M)
- Through the vertex O of parabola $y^2 = 4x$, chords OP and OQ are drawn at right angles to one another. Show that for all positions of P, PQ cuts the axis of the parabola at a fixed point. Also, find the locus of the middle point of PQ . (1994, 4M)

Answers

Topic 1

- | | | | |
|---------|---------|---------|---------|
| 1. (c) | 2. (b) | 3. (a) | 4. (c) |
| 5. (a) | 6. (d) | 7. (c) | 8. (a) |
| 9. (c) | 10. (d) | 11. (c) | 12. (c) |
| 13. (a) | 14. (4) | 15. (4) | |

Topic 2

- | | | | |
|----------------------------|---|---------------|------------|
| 1. (a) | 2. (c) | 3. (c) | 4. (a) |
| 5. (b) | 6. (c) | 7. (b) | 8. (c) |
| 9. (a) | 10. (d) | 11. (c) | 12. (a) |
| 13. (d) | 14. (c) | 15. (a) | 16. (a, b) |
| 17. (d) | 18. (b) | 19. $(-1, 0)$ | |
| 20. $(x+1)(y-1)^2 + 4 = 0$ | 21. $\sqrt{c - \frac{1}{4}}, \frac{1}{2} \leq c \leq 5$ | | |
| 22. (2) | | | |

Topic 3

- | | | |
|-----------------|-----------|---|
| 1. (c) | 2. (b) | 3. $A \rightarrow p; B \rightarrow q; C \rightarrow s; D \rightarrow r$ |
| 4. (a, c, d) | 5. (a, d) | 6. (a, b, d) 7. (a, d) |
| 8. (2) | 9. (2) | 10. $\left(\frac{3}{4}\right)$ |
| 11. $x + y = 3$ | | |

Topic 4

- | | | | |
|---|--------------------|-----------------------------------|-----------|
| 1. (b) | 2. (d) | 3. (b) | 4. (c, d) |
| 5. (b) | 6. (d) | 8. $\left(\frac{15a^2}{4}\right)$ | 9. (2) |
| 10. $\left(\frac{2}{9}, \frac{8}{9}\right)$ | 11. $y^2 = 2(x-4)$ | | |

Hints & Solutions

Topic 1 Equation of Parabola and Focal Chord

- Let a point on parabola $x^2 = 4y$ is $A(x_1, y_1)$,
so $x_1^2 = 4y_1$... (i)
and an another point $P(h, k)$ which divides the line segment joining the point $B(0, -1)$ and $A(x_1, y_1)$ internally in the ratio 1 : 2, so
$$h = \frac{(2 \times 0) + (1 \times x_1)}{2 + 1}$$
and
$$k = \frac{2 \times (-1) + (1 \times y_1)}{2 + 1}$$

 $\Rightarrow x_1 = 3h$ and $y_1 = 3k + 2$... (ii)
Now, on the elimination of (x_1, y_1) with the help of Eq. (i) and relation (ii), we get
$$9h^2 = 4(3k + 2)$$
On taking locus of point $P(h, k)$, we have
$$9x^2 = 12y + 8$$

$$\Rightarrow 9x^2 - 12y = 8$$

Hence, option (c) is correct.

- Vertex of parabola $y^2 = -4(x - a^2)$ is $(a^2, 0)$.

For point of intersection with Y -axis, put $x = 0$ in the given equation of parabola.

$$\text{This gives, } y^2 = 4a^2 \Rightarrow y = \pm 2a$$

Thus, the point of intersection are $(0, 2a)$ and $(0, -2a)$.

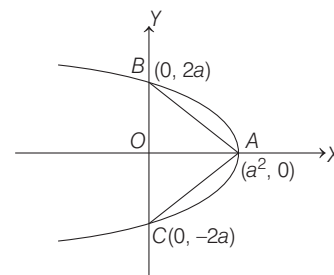

From the given condition, we have

Area of $\triangle ABC = 250$

$$\therefore \frac{1}{2}(BC)(OA) = 250 \quad [\because \text{Area} = \frac{1}{2} \times \text{base} \times \text{height}]$$

$$\Rightarrow \frac{1}{2}(4a)a^2 = 250 \Rightarrow a^3 = 125 = 5^3$$

$$\therefore a = 5$$

3. According to given information, we have the following figure.

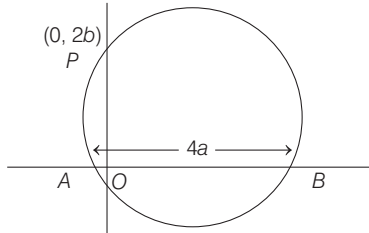

Let the equation of circle be

$$x^2 + y^2 + 2gx + 2fy + c = 0 \quad \dots(i)$$

According to the problem,

$$4a = 2\sqrt{g^2 - c} \quad \dots(ii)$$

[\because The length of intercepts made by the circle $x^2 + y^2 + 2gx + 2fy + c = 0$ with X-axis is $2\sqrt{g^2 - c}$]

Also, as the circle is passing through $P(0, 2b)$

$$\therefore 0 + 4b^2 + 0 + 4bf + c = 0 \quad [\text{using Eq. (i)}]$$

$$\Rightarrow 4b^2 + 4bf + c = 0 \quad \dots(iii)$$

Eliminating 'c' from Eqs. (ii) and (iii), we get

$$4b^2 + 4bf + g^2 - 4a^2 = 0$$

$$[\because 4a = 2\sqrt{g^2 - c} \Rightarrow c = g^2 - 4a^2]$$

So, locus of $(-g, -f)$ is

$$4b^2 - 4by + x^2 - 4a^2 = 0 \Rightarrow x^2 = 4by + 4a^2 - 4b^2$$

which is a parabola.

4. According to given information, we have the following figure.

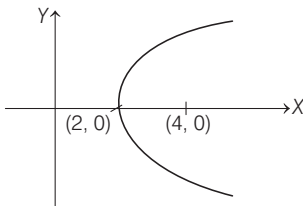

Now, if the origin is shifted to $(2, 0)$ and (X, Y) are the coordinates with respect to new origin, then equation of parabola is $Y^2 = 4aX$,

where, $X = x - 2$ and $Y = y$ and $a = 4 - 2 = 2$

$$\therefore y^2 = 8(x - 2)$$

Note that $(8, 6)$ is the only point which does not satisfy the equation.

5. Centre of circle $x^2 + (y + 6)^2 = 1$ is $C(0, -6)$.

Let the coordinates of point P be $(2t^2, 4t)$.

$$\text{Now, let } D = CP = \sqrt{(2t^2)^2 + (4t + 6)^2}$$

$$\Rightarrow D = \sqrt{4t^4 + 16t^2 + 36 + 48t}$$

Squaring on both sides

$$\Rightarrow D^2(t) = 4t^4 + 16t^2 + 48t + 36$$

$$\text{Let } F(t) = 4t^4 + 16t^2 + 48t + 36$$

For minimum, $F'(t) = 0$

$$\Rightarrow 16t^3 + 32t + 48 = 0 \Rightarrow t^3 + 2t + 3 = 0$$

$$\Rightarrow (t + 1)(t^2 - t + 3) = 0 \Rightarrow t = -1$$

Thus, coordinate of point P are $(2, -4)$.

$$\text{Now, } CP = \sqrt{2^2 + (-4 + 6)^2} = \sqrt{4 + 4} = 2\sqrt{2}$$

Hence, the required equation of circle is

$$(x - 2)^2 + (y + 4)^2 = (2\sqrt{2})^2$$

$$\Rightarrow x^2 + 4 - 4x + y^2 + 16 + 8y = 8$$

$$\Rightarrow x^2 + y^2 - 4x + 8y + 12 = 0$$

6. **PLAN** Any point on the parabola $x^2 = 8y$ is $(4t, 2t^2)$. Point P divides the line segment joining of $O(0, 0)$ and $Q(4t, 2t^2)$ in the ratio $1 : 3$. Apply the section formula for internal division.

Equation of parabola is $x^2 = 8y$

...

Let any point Q on the parabola (i) is $(4t, 2t^2)$.

Let $P(h, k)$ be the point which divides the line segment joining $(0, 0)$ and $(4t, 2t^2)$ in the ratio $1 : 3$.

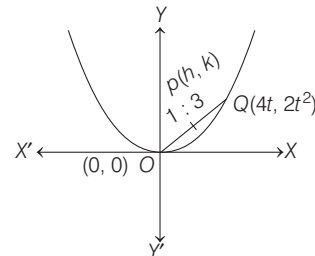

$$\therefore h = \frac{1 \times 4t + 3 \times 0}{4} \Rightarrow h = t$$

$$\text{and } k = \frac{1 \times 2t^2 + 3 \times 0}{4} \Rightarrow k = \frac{t^2}{2}$$

$$\Rightarrow k = \frac{1}{2}h^2 \Rightarrow 2k = h^2 \quad [\because t = h]$$

$$\Rightarrow 2y = x^2, \text{ which is required locus.}$$

7. By section formula,

$$h = \frac{x + 0}{4}, k = \frac{y + 0}{4}$$

$$\therefore x = 4h, y = 4k$$

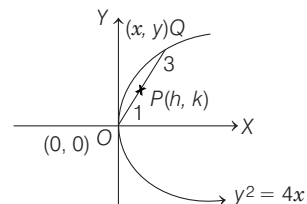

446 Parabola

Substituting in $y^2 = 4x$,
 $(4k)^2 = 4(4h)$
 $\Rightarrow k^2 = h$
 or $y^2 = x$ is required locus.

8. Since, distance of vertex from origin is $\sqrt{2}$ and focus is $2\sqrt{2}$.

$\therefore V(1, 1)$ and $F(2, 2)$ (i.e. lying on $y = x$)
 where, length of latusrectum
 $= 4a = 4\sqrt{2}$ [$\because a = \sqrt{2}$]
 \therefore By definition of parabola

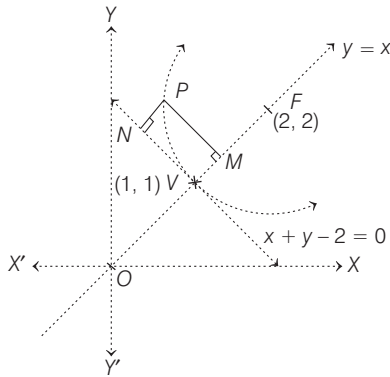

$$PM^2 = (4a)(PN)$$

where, PN is length of perpendicular upon $x + y - 2 = 0$, i.e. tangent at vertex

$$\Rightarrow \frac{(x-y)^2}{2} = 4\sqrt{2} \left(\frac{x+y-2}{\sqrt{2}} \right)$$

$$\Rightarrow (x-y)^2 = 8(x+y-2)$$

9. Let $P(h, k)$ be the mid-point of the line segment joining the focus $(a, 0)$ and a general point $Q(x, y)$ on the parabola. Then,

$$h = \frac{x+a}{2}, k = \frac{y}{2} \Rightarrow x = 2h - a, y = 2k.$$

Put these values of x and y in $y^2 = 4ax$, we get

$$4k^2 = 4a(2h - a)$$

$$\Rightarrow 4k^2 = 8ah - 4a^2 \Rightarrow k^2 = 2ah - a^2$$

So, locus of $P(h, k)$ is $y^2 = 2ax - a^2$

$$\Rightarrow y^2 = 2a \left(x - \frac{a}{2} \right)$$

Its directrix is $x - \frac{a}{2} = -\frac{a}{2} \Rightarrow x = 0$.

10. Given, $y^2 + 4y + 4x + 2 = 0$

$$\Rightarrow (y+2)^2 + 4x - 2 = 0$$

$$\Rightarrow (y+2)^2 = -4 \left(x - \frac{1}{2} \right)$$

Replace $y + 2 = Y, x - \frac{1}{2} = X$

$$\text{We have, } Y^2 = -4X$$

This is a parabola with directrix at $X = 1$

$$\Rightarrow x - \frac{1}{2} = 1 \Rightarrow x = \frac{3}{2}$$

11. Given, $y^2 = kx - 8$

$$\Rightarrow y^2 = k \left(x - \frac{8}{k} \right)$$

Shifting the origin $Y^2 = kX$, where $Y = y, X = x - 8/k$.

Directrix of standard parabola is $X = -\frac{k}{4}$

Directrix of original parabola is $x = \frac{8}{k} - \frac{k}{4}$

Now, $x = 1$ also coincides with $x = \frac{8}{k} - \frac{k}{4}$

On solving, we get $k = 4$

12. Given curves are $x = t^2 + t + 1$... (i)

and $y = t^2 - t + 1$... (ii)

On subtracting Eq. (ii) from Eq. (i),

$$x - y = 2t$$

Thus,

$$x = t^2 + t + 1$$

$$\Rightarrow x = \left(\frac{x-y}{2} \right)^2 + \left(\frac{x-y}{2} \right) + 1$$

$$\Rightarrow 4x = (x-y)^2 + 2x - 2y + 4$$

$$\Rightarrow (x-y)^2 = 2(x+y-2)$$

$$\Rightarrow x^2 + y^2 - 2xy - 2x - 2y + 4 = 0$$

$$\text{Now, } \Delta = 1 \cdot 1 \cdot 4 + 2 \cdot (-1) \cdot (-1) \cdot (-1)$$

$$-1 \times (-1)^2 - 1 \times (-1)^2 - 4 \cdot (-1)^2$$

$$= 4 - 2 - 1 - 1 - 4 = -4$$

$$\therefore \Delta \neq 0$$

$$\text{and } ab - h^2 = 1 \cdot 1 - (-1)^2 = 1 - 1 = 0$$

Hence, it represents an equation of parabola.

13. $y = -\frac{x^2}{2} + x + 1 \Rightarrow y - \frac{3}{2} = -\frac{1}{2}(x-1)^2$

\Rightarrow It is symmetric about $x = 1$.

Hence, option (a) is correct.

14. Let $P(t^2, 2t)$ be a point on the curve $y^2 = 4x$, whose image is $Q(x, y)$ on $x + y + 4 = 0$, then

$$\frac{x-t^2}{1} = \frac{y-2t}{1} = \frac{-2(t^2+2t+4)}{1^2+1^2}$$

$$\Rightarrow x = -2t - 4$$

$$\text{and } y = -t^2 - 4$$

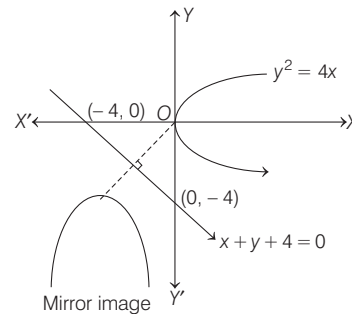

Now, the straight line $y = -5$ meets the mirror image.

$$\therefore -t^2 - 4 = -5$$

$$\Rightarrow t^2 = 1$$

$$\Rightarrow t = \pm 1$$

Thus, points of intersection of A and B are $(-6, -5)$ and $(-2, -5)$.

$$\therefore \text{Distance, } AB = \sqrt{(-2+6)^2 + (-5+5)^2} = 4$$

15. **PLAN** Parametric coordinates for $y^2 = 4ax$ are $(at^2, 2at)$.

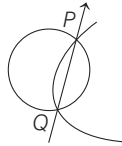

Description of Situation As the circle intersects the parabola at P and Q . Thus, points P and Q should satisfy circle.

$$P(2t^2, 4t) \text{ should lie on } x^2 + y^2 - 2x - 4y = 0$$

$$\Rightarrow 4t^4 + 16t^2 - 4t^2 - 16t = 0$$

$$\Rightarrow 4t^4 + 12t^2 - 16t = 0$$

$$\Rightarrow 4t(t^3 + 3t - 4) = 0$$

$$\Rightarrow 4t(t-1)(t^2 + t + 4) = 0$$

$$\therefore t = 0, 1$$

$$\Rightarrow P(2, 4) \text{ and } PQ \text{ is the diameter of circle.}$$

$$\text{Thus, area of } \Delta PQS = \frac{1}{2} \cdot OS \times PQ = \frac{1}{2} \cdot (2) \cdot (4) = 4$$

Topic 2 Equation of Tangents and Properties

1. Since equation of tangent to the parabola $y^2 = 4(x+1)$ having slope 'm' is

$$y = m(x+1) + \frac{1}{m}$$

$$\Rightarrow y = mx + \left(m + \frac{1}{m}\right) \quad \dots(i)$$

Similarly, equation of tangent to the parabola $y^2 = 8(x+2)$ having slope m' is

$$y = m'(x+2) + \frac{2}{m'}$$

$$\Rightarrow y = m'x + \left(2m' + \frac{2}{m'}\right) \quad \dots(ii)$$

\therefore It is given that tangents (i) and (ii) are perpendicular so $mm' = -1$

\therefore Eq. (ii) becomes as

$$y = -\frac{1}{m}x - 2m - \frac{2}{m} \quad \dots(iii)$$

Let tangents (i) and (iii) intersects each other at point $P(h, k)$, so

$$(h+1)m^2 - km + 1 = 0$$

and $2m^2 + km + (h+2) = 0$

$$\therefore \frac{h+1}{2} = \frac{-k}{k} = \frac{1}{h+2} \Rightarrow h+3=0$$

On taking locus of point $P(h, k)$, we get $x+3=0$

2. **Key Idea** Use the equation of tangent of slope 'm' to the parabola $y^2 = 4ax$ is $y = mx + \frac{a}{m}$ and a line $ax + by + c = 0$ touches the circle $x^2 + y^2 = r^2$, if $\frac{|c|}{\sqrt{a^2 + b^2}} = r$.

Since, equation of given parabola is $y^2 = 4\sqrt{2}x$ and equation of tangent line is $ax + y = c$ or $y = -ax + c$,

$$\text{then } c = \frac{\sqrt{2}}{m} = \frac{\sqrt{2}}{-a} \quad [\because m = \text{slope of line} = -a]$$

$[\because$ line $y = mx + c$ touches the parabola $y^2 = 4ax$ iff $c = a/m]$.

Then, equation of tangent line becomes

$$y = -ax - \frac{\sqrt{2}}{a} \quad \dots(i)$$

\therefore Line (i) is also tangent to the circle $x^2 + y^2 = 1$.

$$\therefore \text{Radius} = 1 = \frac{\left| -\frac{\sqrt{2}}{a} \right|}{\sqrt{1+a^2}} \Rightarrow \sqrt{1+a^2} = \left| -\frac{\sqrt{2}}{a} \right|$$

$$\Rightarrow 1 + a^2 = \frac{2}{a^2} \quad [\text{squaring both sides}]$$

$$\Rightarrow a^4 + a^2 - 2 = 0$$

$$\Rightarrow (a^2 + 2)(a^2 - 1) = 0$$

$$\Rightarrow a^2 = 1 \quad [\because a^2 > 0, \forall a \in R]$$

$$\therefore |c| = \frac{\sqrt{2}}{|a|} = \sqrt{2}$$

3. Given equation of parabola is

$$y = (x-2)^2 - 1$$

$$\Rightarrow y = x^2 - 4x + 3 \quad \dots(i)$$

Now, let (x_1, y_1) be the point of intersection of tangents of parabola (i) and line $x - y = 3$, then

Equation of chord of contact of point (x_1, y_1) w.r.t. parabola (i) is

$$T = 0$$

$$\Rightarrow \frac{1}{2}(y + y_1) = xx_1 - 2(x + x_1) + 3$$

$$\Rightarrow y + y_1 = 2x(x_1 - 2) - 4x_1 + 6$$

$\Rightarrow 2x(x_1 - 2) - y = 4x_1 + y_1 - 6$, this equation represent the line $x - y = 3$ only, so on comparing, we get

$$\frac{2(x_1 - 2)}{1} = \frac{-1}{-1} = \frac{4x_1 + y_1 - 6}{3}$$

$$\Rightarrow x_1 = \frac{5}{2} \text{ and } y_1 = -1$$

So, the required point is $\left(\frac{5}{2}, -1\right)$.

4. Given parabola $y^2 = 4x$... (i)

So, equation of tangent to parabola (i) at point $(1, 2)$ is $2y = 2(x+1)$

$$[\because \text{equation of the tangent to the parabola } y^2 = 4ax \text{ at a point } (x_1, y_1) \text{ is given by } yy_1 = 2a(x + x_1)]$$

$$\Rightarrow y = x + 1 \quad \dots(ii)$$

448 Parabola

Now, equation of circle, touch the parabola at point (1, 2) is

$$(x-1)^2 + (y-2)^2 + \lambda(x-y+1) = 0$$

$$\Rightarrow x^2 + y^2 + (\lambda-2)x + (-4-\lambda)y + (5+\lambda) = 0 \quad \dots(\text{iii})$$

Also, Circle (iii) touches the x-axis, so $g^2 = c$

$$\Rightarrow \left(\frac{\lambda-2}{2}\right)^2 = 5 + \lambda$$

$$\Rightarrow \lambda^2 - 4\lambda + 4 = 4\lambda + 20$$

$$\Rightarrow \lambda^2 - 8\lambda - 16 = 0$$

$$\Rightarrow \lambda = \frac{8 \pm \sqrt{64 + 64}}{2}$$

$$\Rightarrow \lambda = 4 \pm \sqrt{32} = 4 \pm 4\sqrt{2}$$

Now, radius of circle is $r = \sqrt{g^2 + f^2 - c}$

$$\Rightarrow r = |f| = \left| \frac{\lambda+4}{2} \right| = \frac{8+4\sqrt{2}}{2} \text{ or } \frac{8-4\sqrt{2}}{2} \quad [\because g^2 = c]$$

For least area $r = \frac{8-4\sqrt{2}}{2} = 4-2\sqrt{2}$ units

So, area = $\pi r^2 = \pi(16+8-16\sqrt{2}) = 8\pi(3-2\sqrt{2})$ sq unit

5. Given parabola is $x^2 = 8y$... (i)

Now, slope of tangent at any point (x, y) on the parabola (i) is

$$\frac{dy}{dx} = \frac{x}{4} = \tan \theta$$

[\because tangent is making an angle θ with the positive direction of X-axis]

So, $x = 4 \tan \theta$

$$\Rightarrow 8y = (4 \tan \theta)^2$$

[on putting $x = 4 \tan \theta$ in Eq. (i)]

$$\Rightarrow y = 2 \tan^2 \theta$$

Now, equation of required tangent is

$$y - 2 \tan^2 \theta = \tan \theta (x - 4 \tan \theta)$$

$$\Rightarrow y = x \tan \theta - 2 \tan^2 \theta \Rightarrow x = y \cot \theta + 2 \tan \theta$$

6. We know that, equation of tangent to parabola $y^2 = 4ax$ is

$$y = mx + \frac{a}{m}$$

\therefore Equation of tangent to the parabola $y^2 = 4x$ is

$$y = mx + \frac{1}{m} \quad (\because a = 1)$$

$$\Rightarrow m^2x - my + 1 = 0 \quad \dots(\text{i})$$

Now, let line (i) is also a tangent to the circle.

Equation of circle $x^2 + y^2 - 6x = 0$

Clearly, centre of given circle is (3, 0) and radius = 3

[\because for the circle $x^2 + y^2 + 2gx + 2fy + c = 0$, centre = $(-g, -f)$ and radius = $\sqrt{g^2 + f^2 - c}$]

\therefore The perpendicular distance of (3, 0) from the line (i) is 3.

[\because Radius is perpendicular to the tangent of circle]

$$\Rightarrow \frac{|m^2 \cdot 3 - m \cdot 0 + 1|}{\sqrt{(m^2)^2 + (-m)^2}} = 3$$

The length of perpendicular from a point (x_1, y_1) to the

line $ax + by + c = 0$ is $\left| \frac{ax_1 + by_1 + c}{\sqrt{a^2 + b^2}} \right|$.

$$\Rightarrow \frac{3m^2 + 1}{\sqrt{m^4 + m^2}} = 3$$

$$\Rightarrow 9m^4 + 6m^2 + 1 = 9(m^4 + m^2)$$

$$\Rightarrow m \approx \infty \text{ or } m = \pm \frac{1}{\sqrt{3}}$$

$$\left[\because \lim_{m \rightarrow \infty} \frac{3m^2 + 1}{\sqrt{m^4 + m^2}} = \lim_{m \rightarrow \infty} \frac{3 + \frac{1}{m^2}}{\sqrt{1 + \frac{1}{m^2}}} = 3 \right]$$

\therefore Equation of common tangents are $x = 0$,

$$y = \frac{x}{\sqrt{3}} + \sqrt{3} \text{ and } y = \frac{-x}{\sqrt{3}} - \sqrt{3} \quad \left(\text{using } y = mx + \frac{1}{m} \right)$$

i.e. $x = 0$, $\sqrt{3}y = x + 3$ and $\sqrt{3}y = -x - 3$

7. Equation of tangent and normal to the curve $y^2 = 16x$ at (16, 16) is $x - 2y + 16 = 0$ and $2x + y - 48 = 0$, respectively.

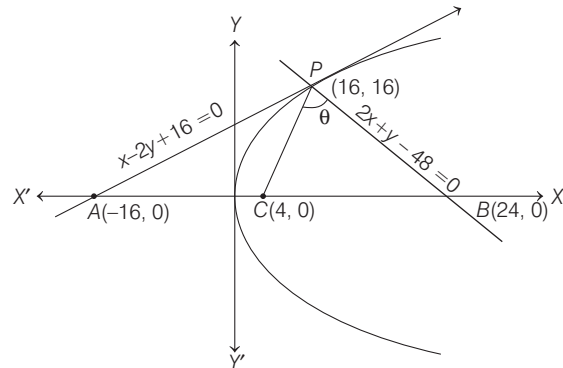

$$A = (-16, 0); \quad B = (24, 0)$$

$\therefore C$ is the centre of circle passing through PAB

i.e. $C = (4, 0)$
Slope of $PC = \frac{16-0}{16-4} = \frac{16}{12} = \frac{4}{3} = m_1$

Slope of $PB = \frac{16-0}{16-24} = \frac{16}{-8} = -2 = m_2$

$$\tan \theta = \left| \frac{m_1 - m_2}{1 + m_1 m_2} \right|$$

$$\Rightarrow \tan \theta = \left| \frac{\frac{4}{3} + 2}{1 - \left(\frac{4}{3}\right)(-2)} \right|$$

$$\Rightarrow \tan \theta = 2$$

8. Let the radius of circle with least area be r .
Then, then coordinates of centre = $(0, 4 - r)$.

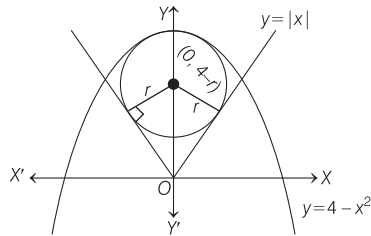

Since, circle touches the line $y = x$ in first quadrant

$$\therefore \left| \frac{0 - (4 - r)}{\sqrt{2}} \right| = r \Rightarrow r - 4 = \pm r\sqrt{2}$$

$$\Rightarrow r = \frac{4}{\sqrt{2} + 1} \text{ or } \frac{4}{1 - \sqrt{2}}$$

But $r \neq \frac{4}{1 - \sqrt{2}}$ [$\because \frac{4}{1 - \sqrt{2}} < 0$]

$$\therefore r = \frac{4}{\sqrt{2} + 1} = 4(\sqrt{2} - 1)$$

9. Let the tangent to parabola be $y = mx + a/m$, if it touches the other curve, then $D = 0$, to get the value of m .
For parabola, $y^2 = 4x$

Let $y = mx + \frac{1}{m}$ be tangent line and it touches the

parabola $x^2 = -32y$
 $\therefore x^2 = -32\left(mx + \frac{1}{m}\right)$

$$\Rightarrow x^2 + 32mx + \frac{32}{m} = 0$$

$$D = 0$$

$$\therefore (32m)^2 - 4 \cdot \left(\frac{32}{m}\right) = 0 \Rightarrow m^3 = 1/8$$

$$\therefore m = 1/2$$

10. The tangent at $(1, 7)$ to the parabola $x^2 = y - 6x$ is

$$x(1) = \frac{1}{2}(y + 7) - 6$$

[replacing $x^2 \rightarrow xx_1$ and $2y \rightarrow y + y_1$]

$$\Rightarrow 2x = y + 7 - 12$$

$$\Rightarrow y = 2x + 5 \quad \dots(i)$$

which is also tangent to the circle

$$x^2 + y^2 + 16x + 12y + c = 0$$

i.e. $x^2 + (2x + 5)^2 + 16x + 12(2x + 5) + C = 0$ must have equal roots i.e., $\alpha = \beta$

$$\Rightarrow 5x^2 + 60x + 85 + c = 0$$

$$\Rightarrow \alpha + \beta = \frac{-60}{5}$$

$$\Rightarrow \alpha = -6$$

$$\therefore x = -6 \text{ and } y = 2x + 5 = -7$$

\therefore Point of contact is $(-6, -7)$.

11. We know, tangent to $y^2 = 4ax$ is $y = mx + \frac{a}{m}$.

$$\therefore \text{Tangent to } y^2 = 4x \text{ is } y = mx + \frac{1}{m}$$

Since, tangent passes through $(1, 4)$.

$$\therefore 4 = m + \frac{1}{m}$$

$$\Rightarrow m^2 - 4m + 1 = 0 \quad (\text{whose roots are } m_1 \text{ and } m_2)$$

$$\therefore m_1 + m_2 = 4 \text{ and } m_1 m_2 = 1$$

$$\text{and } |m_1 - m_2| = \sqrt{(m_1 + m_2)^2 - 4m_1 m_2} \\ = \sqrt{16 - 4} = 2\sqrt{3}$$

Thus, angle between tangents

$$\tan \theta = \frac{|m_2 - m_1|}{|1 + m_1 m_2|} = \frac{|2\sqrt{3}|}{|1 + 1|} = \sqrt{3} \Rightarrow \theta = \frac{\pi}{3}$$

12. Here, the focal chord of $y^2 = 16x$ is tangent to circle $(x - 6)^2 + y^2 = 2$.

\Rightarrow Focus of parabola as $(a, 0)$ i.e. $(4, 0)$

Now, tangents are drawn from $(4, 0)$ to $(x - 6)^2 + y^2 = 2$.

Since, PA is tangent to circle.

$$\therefore \tan \theta = \text{slope of tangent} = \frac{AC}{AP} = \frac{\sqrt{2}}{\sqrt{2}} = 1$$

or $\frac{BC}{BP} = -1$

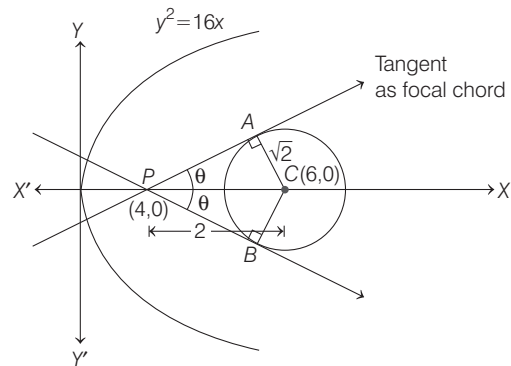

\therefore Slope of focal chord as tangent to circle = ± 1

13. Tangent to the curve $y^2 = 8x$ is $y = mx + \frac{2}{m}$. So, it must

satisfy $xy = -1$

$$\Rightarrow x \left(mx + \frac{2}{m} \right) = -1$$

$$\Rightarrow mx^2 + \frac{2}{m}x + 1 = 0$$

Since, it has equal roots.

$$\therefore D = 0$$

$$\Rightarrow \frac{4}{m^2} - 4m = 0$$

$$\Rightarrow m^3 = 1$$

$$\Rightarrow m = 1$$

Hence, equation of common tangent is $y = x + 2$.

450 Parabola

14. Any tangent to $y^2 = 4x$ is of the form $y = mx + \frac{1}{m}$,
 ($\because a = 1$) and this touches the circle $(x - 3)^2 + y^2 = 9$.

$$\text{If } \left| \frac{m(3) + \frac{1}{m} - 0}{\sqrt{m^2 + 1}} \right| = 3$$

[\because centre of the circle is $(3, 0)$ and radius is 3].

$$\begin{aligned} \Rightarrow \frac{3m^2 + 1}{m} &= \pm 3\sqrt{m^2 + 1} \\ \Rightarrow 3m^2 + 1 &= \pm 3m\sqrt{m^2 + 1} \\ \Rightarrow 9m^4 + 1 + 6m^2 &= 9m^2(m^2 + 1) \\ \Rightarrow 9m^4 + 1 + 6m^2 &= 9m^4 + 9m^2 \\ \Rightarrow 3m^2 &= 1 \\ \Rightarrow m &= \pm \frac{1}{\sqrt{3}} \end{aligned}$$

If the tangent touches the parabola and circle above the X -axis, then slope m should be positive.

$$\therefore m = \frac{1}{\sqrt{3}} \text{ and the equation is } y = \frac{1}{\sqrt{3}}x + \sqrt{3}$$

$$\text{or } \sqrt{3}y = x + 3.$$

15. Equation of circle can be rewritten as $x^2 + y^2 = \frac{5}{2}$.

$$\text{Centre} \rightarrow (0, 0) \text{ and radius} \rightarrow \sqrt{\frac{5}{2}}$$

Let common tangent be

$$y = mx + \frac{\sqrt{5}}{m} \Rightarrow m^2x - my + \sqrt{5} = 0$$

The perpendicular from centre to the tangent is equal to radius of the circle.

$$\therefore \frac{\sqrt{5}/m}{\sqrt{1+m^2}} = \sqrt{\frac{5}{2}}$$

$$\Rightarrow m\sqrt{1+m^2} = \sqrt{2}$$

$$\Rightarrow m^2(1+m^2) = 2$$

$$\Rightarrow m^4 + m^2 - 2 = 0$$

$$\Rightarrow (m^2 + 2)(m^2 - 1) = 0$$

$$\Rightarrow m = \pm 1 \quad [\because m^2 + 2 \neq 0, \text{ as } m \in R]$$

$\therefore y = \pm(x + \sqrt{5})$, both statements are correct as $m \pm 1$ satisfies the given equation of Statement II.

16. The equation of tangent to $y = x^2$, be $y = mx - \frac{m^2}{4}$.

Putting in $y = -x^2 + 4x - 4$, we should only get one value of x i.e. Discriminant must be zero.

$$\therefore mx - \frac{m^2}{4} = -x^2 + 4x - 4$$

$$\Rightarrow x^2 + x(m - 4) + 4 - \frac{m^2}{4} = 0$$

$$D = 0$$

$$\text{Now, } (m - 4)^2 - (16 - m^2) = 0$$

$$\Rightarrow 2m(m - 4) = 0 \Rightarrow m = 0, 4$$

$\therefore y = 0$ and $y = 4(x - 1)$ are the required tangents.

Hence, (a) and (b) are correct answers.

17. **PLAN** (i) If $P(at^2, 2at)$ is one end point of focal chord of parabola $y^2 = 4ax$, then other end point is $(\frac{a}{t^2}, -\frac{2a}{t})$.

(ii) Slope of line joining two points (x_1, y_1) and (x_2, y_2) is given by $\frac{y_2 - y_1}{x_2 - x_1}$.

If PQ is focal chord, then coordinates of Q will be

$$\left(\frac{a}{t^2}, -\frac{2a}{t}\right).$$

Now, slope of $QR =$ slope of PK

$$\frac{2ar + \frac{2a}{t}}{ar^2 - \frac{a}{t^2}} = \frac{2at}{at^2 - 2a} \Rightarrow \frac{r + 1/t}{r^2 - 1/t^2} = \frac{t}{t^2 - 2}$$

$$\Rightarrow \frac{1}{r - \frac{1}{t}} = \frac{t}{t^2 - 2} \Rightarrow r - \frac{1}{t} = \frac{t^2 - 2}{t} = t - \frac{2}{t}$$

$$\Rightarrow r = t - \frac{1}{t} = \frac{t^2 - 1}{t}$$

18. **PLAN** Equation of tangent and normal at $(at^2, 2at)$ are given by $ty = x + at^2$ and $y + tx = 2at + at^3$, respectively.

$$\text{Tangent at } P: ty = x + at^2 \text{ or } y = \frac{x}{t} + at$$

$$\text{Normal at } S: y + \frac{x}{t} = \frac{2a}{t} + \frac{a}{t^3}$$

$$\text{Solving, } 2y = at + \frac{2a}{t} + \frac{a}{t^3} \Rightarrow y = \frac{a(t^2 + 1)^2}{2t^3}$$

19. The coordinates of extremities of the latusrectum of $y^2 = 4x$ are $(1, 2)$ and $(1, -2)$.

Equations of tangents at these points are

$$y \cdot 2 = \frac{4(x + 1)}{2} \Rightarrow 2y = 2(x + 1) \quad \dots(i)$$

$$\text{and } y(-2) = \frac{4(x + 1)}{2}$$

$$\Rightarrow -2y = 2(x + 1) \quad \dots(ii)$$

The point of intersection of these tangents can be obtained by solving Eqs. (i) and (ii) simultaneously.

$$\therefore -2(x + 1) = 2(x + 1)$$

$$\Rightarrow 0 = 4(x + 1)$$

$$\Rightarrow -1 = x \Rightarrow y = 0$$

Therefore, the required point is $(-1, 0)$.

20. Given equation can be rewritten as

$$(y - 1)^2 = 4(x - 1), \text{ whose parametric coordinates are}$$

$$x - 1 = t^2 \text{ and } y - 1 = 2t$$

$$\text{i.e. } P(1 + t^2, 1 + 2t)$$

∴ Equation of tangent at P is,
 $t(y - 1) = x - 1 + t^2$, which meets the directrix $x = 0$ at Q .
 $\Rightarrow y = 1 + t - \frac{1}{t}$ or $Q\left(0, 1 + t - \frac{1}{t}\right)$

Let $R(h, k)$ which divides QP externally in the ratio $\frac{1}{2} : 1$ or Q is mid-point of RP .

$$\Rightarrow 0 = \frac{h + t^2 + 1}{2} \text{ or } t^2 = -(h + 1) \quad \dots(i)$$

$$\text{and } 1 + t - \frac{1}{t} = \frac{k + 2t + 1}{2} \text{ or } t = \frac{2}{1 - k} \quad \dots(ii)$$

From Eqs. (i) and (ii), $\frac{4}{(1 - k)^2} + (h + 1) = 0$

$$\text{or } (k - 1)^2 (h + 1) + 4 = 0$$

∴ Locus of a point is $(x + 1)(y - 1)^2 + 4 = 0$

21. Let the point $Q(x, x^2)$ on $x^2 = y$ whose distance from $(0, c)$ is minimum.

Now, $PQ^2 = x^2 + (x^2 - c)^2$

Let $f(x) = x^2 + (x^2 - c)^2 \quad \dots(i)$

$$f'(x) = 2x + 2(x^2 - c) \cdot 2x$$

$$= 2x(1 + 2x^2 - 2c) = 4x\left(x^2 - c + \frac{1}{2}\right)$$

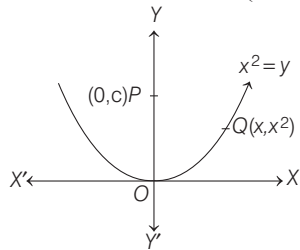

$$= 4x\left(x - \sqrt{c - \frac{1}{2}}\right)\left(x + \sqrt{c - \frac{1}{2}}\right), \text{ when } c > \frac{1}{2}$$

For maxima, put $f'(x) = 0$

$$4x\left(x^2 - c + \frac{1}{2}\right) = 0 \Rightarrow x = 0, x = \pm\sqrt{c - \frac{1}{2}}$$

Now, $f''(x) = 4\left[x^2 - c + \frac{1}{2}\right] + 4x[2x]$

At $x = \pm\sqrt{c - \frac{1}{2}} \Rightarrow f''(x) \geq 0$.

∴ $f(x)$ is minimum.

Hence, minimum value of $f(x) = |PQ|$

$$= \sqrt{\left(\sqrt{c - \frac{1}{2}}\right)^2 + \left(\left(\sqrt{c - \frac{1}{2}}\right)^2 - c\right)^2}$$

$$= \sqrt{c - \frac{1}{2} + \left(c - \frac{1}{2} - c\right)^2} = \sqrt{c - \frac{1}{4}}, \frac{1}{2} \leq c \leq 5$$

22. As, we know area of Δ formed by three points on parabola is twice the area of Δ formed by corresponding tangents i.e. area of $\Delta PQR = 2$ area of $\Delta T_1T_2T_3$.

$$\therefore \Delta_1 = 2\Delta_2 \text{ or } \frac{\Delta_1}{\Delta_2} = 2$$

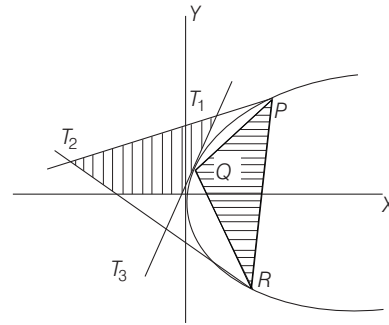

Topic 3 Equation of Normal and Properties

1. Normal to parabola $y^2 = 4ax$ is given by

$$y = mx - 2am - am^3$$

∴ Normal to parabola

$$y^2 = 4b(x - c) \text{ is}$$

$$y = m(x - c) - 2bm - bm^3$$

[replacing a by b and x by $x - c$]

$$= mx - (2b + c)m - bm^3 \quad \dots(i)$$

and normal to parabola $y^2 = 8ax$ is

$$y = mx - 4am - 2am^3 \quad \dots(ii)$$

[replacing a by $2a$]

For common normal, we should have

$$mx - 4am - 2am^3 = mx - (2b + c)m - bm^3$$

[using Eqs. (i) and (ii)]

$$4am + 2am^3 = (2b + c)m + bm^3$$

$$\Rightarrow (2a - b)m^3 + (4a - 2b - c)m = 0$$

$$\Rightarrow m((2a - b)m^2 + (4a - 2b - c)) = 0$$

$$\Rightarrow m = 0$$

$$\text{or } m^2 = \frac{2b + c - 4a}{2a - b} = \frac{c}{2a - b} - 2$$

As, $m^2 > 0$, therefore $\frac{c}{2a - b} > 2$

Note that if $m = 0$, then all options satisfy

(∵ $y = 0$ is a common normal) and if common normal is other than the axis, then only option (c) satisfies

[∵ for option (c), $2a - b = \frac{3}{2 - 1} = 3 > 2$]

2. If $y = mx + c$ is normal to the parabola $y^2 = 4ax$, then $c = -2am - am^3$.

From given condition, $y^2 = 12x$

$$\Rightarrow y^2 = 4 \cdot 3 \cdot x$$

$$\Rightarrow a = 3$$

$$\text{And } x + y = k$$

$$\Rightarrow y = (-1)x + k$$

$$\Rightarrow m = -1$$

$$\text{and } c = k$$

$$\therefore c = k = -2(3)(-1) - 3(-1)^3 = 9$$

452 Parabola

3. Since, equation of normal to the parabola $y^2 = 4ax$ is $y + xt = 2at + at^3$ passes through $(3, 0)$.

$$\Rightarrow 3t = 2t + t^3 \quad [\because a = 1]$$

$$\Rightarrow t = 0, 1, -1$$

\therefore Coordinates of the normals are $P(1, 2), Q(0, 0), R(1, -2)$.

Thus,

A. Area of $\Delta PQR = \frac{1}{2} \times 1 \times 4 = 2$

C. Centroid of $\Delta PQR = \left(\frac{2}{3}, 0\right)$

Equation of circle passing through P, Q, R is

$$(x-1)(x-1) + (y-2)(y+2) + \lambda(x-1) = 0$$

$$\Rightarrow 1 - 4 - \lambda = 0$$

$$\Rightarrow \lambda = -3$$

\therefore Required equation of circle is

$$x^2 + y^2 - 5x = 0$$

\therefore Centre $\left(\frac{5}{2}, 0\right)$ and radius $\frac{5}{2}$.

4. Tangent to $y^2 = 4x$ at $(t^2, 2t)$ is

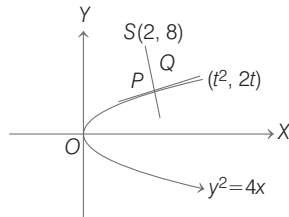

$$y(2t) = 2(x + t^2)$$

$$\Rightarrow yt = x + t^2 \quad \dots(i)$$

Equation of normal at $P(t^2, 2t)$ is

$$y + tx = 2t + t^3$$

Since, normal at P passes through centre of circle $S(2, 8)$.

$$\therefore 8 + 2t = 2t + t^3$$

$$\Rightarrow t = 2, \text{ i.e. } P(4, 4)$$

[since, shortest distance between two curves lie along their common normal and the common normal will pass through the centre of circle]

$$\therefore SP = \sqrt{(4-2)^2 + (4-8)^2} = 2\sqrt{5}$$

\therefore Option (a) is correct.

Also,

$$SQ = 2$$

$$\therefore PQ = SP - SQ = 2\sqrt{5} - 2$$

Thus,
$$\frac{SQ}{QP} = \frac{1}{\sqrt{5}-1} = \frac{\sqrt{5}+1}{4}$$

\therefore Option (b) is wrong.

Now, x -intercept of normal is $x = 2 + 2^2 = 6$

\therefore Option (c) is correct.

Slope of tangent $= \frac{1}{t} = \frac{1}{2}$

\therefore Option (d) is correct.

5. Given, $(x^2 + xy + 4x + 2y + 4)\frac{dy}{dx} - y^2 = 0$

$$\Rightarrow [(x^2 + 4x + 4) + y(x + 2)]\frac{dy}{dx} - y^2 = 0$$

$$\Rightarrow [(x+2)^2 + y(x+2)]\frac{dy}{dx} - y^2 = 0$$

Put $x + 2 = X$ and $y = Y$, then

$$(X^2 + XY)\frac{dY}{dX} - Y^2 = 0$$

$$\Rightarrow X^2 dY + XY dY - Y^2 dX = 0$$

$$\Rightarrow X^2 dY + Y(X dY - Y dX) = 0$$

$$\Rightarrow -\frac{dY}{Y} = \frac{XdY - YdX}{X^2}$$

$$\Rightarrow -d(\log |Y|) = d\left(\frac{Y}{X}\right)$$

On integrating both sides, we get

$$-\log |Y| = \frac{Y}{X} + C, \text{ where } x + 2 = X$$

and $y = Y$

$$\Rightarrow -\log |y| = \frac{y}{x+2} + C \quad \dots(i)$$

Since, it passes through the point $(1, 3)$.

$$\therefore -\log 3 = 1 + C$$

$$\Rightarrow C = -1 - \log 3 = -(\log e + \log 3) = -\log 3e$$

\therefore Eq. (i) becomes

$$\log |y| + \frac{y}{x+2} - \log(3e) = 0$$

$$\Rightarrow \log\left(\frac{|y|}{3e}\right) + \frac{y}{x+2} = 0 \quad \dots(ii)$$

Now, to check option (a), $y = x + 2$ intersects the curve.

$$\Rightarrow \log\left(\frac{|x+2|}{3e}\right) + \frac{x+2}{x+2} = 0$$

$$\Rightarrow \log\left(\frac{|x+2|}{3e}\right) = -1$$

$$\Rightarrow \frac{|x+2|}{3e} = e^{-1} = \frac{1}{e}$$

$$\Rightarrow |x+2| = 3 \text{ or } x+2 = \pm 3$$

$$\therefore x = 1, -5 \text{ (rejected), as } x > 0$$

[given]

$\therefore x = 1$ only one solution.

Thus, (a) is the correct answer.

To check option (c), we have

$$y = (x+2)^2 \text{ and } \log\left(\frac{|y|}{3e}\right) + \frac{y}{x+2} = 0$$

$$\Rightarrow \log\left[\frac{|x+2|^2}{3e}\right] + \frac{(x+2)^2}{x+2} = 0$$

$$\Rightarrow \log\left[\frac{|x+2|^2}{3e}\right] = -(x+2)$$

$$\Rightarrow \frac{(x+2)^2}{3e} = e^{-(x+2)} \text{ or } (x+2)^2 \cdot e^{x+2} = 3e$$

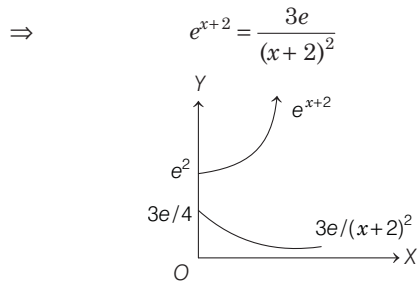

Clearly, they have no solution.

To check option (d), $y = (x+3)^2$

i.e. $\log \left[\frac{|x+3|^2}{3e} \right] + \frac{(x+3)^2}{(x+2)} = 0$

To check the number of solutions.

Let $g(x) = 2 \log(x+3) + \frac{(x+3)^2}{(x+2)} - \log(3e)$

$$\begin{aligned} \therefore g'(x) &= \frac{2}{x+3} + \left(\frac{(x+2) \cdot 2(x+3) - (x+3)^2 \cdot 1}{(x+2)^2} \right) - 0 \\ &= \frac{2}{x+3} + \frac{(x+3)(x+1)}{(x+2)^2} \end{aligned}$$

Clearly, when $x > 0$, then, $g'(x) > 0$

$\therefore g(x)$ is increasing, when $x > 0$.

Thus, when $x > 0$, then $g(x) > g(0)$

$$g(x) > \log\left(\frac{3}{e}\right) + \frac{9}{4} > 0$$

Hence, there is no solution.

Thus, option (d) is true.

6. Normal to $y^2 = 4x$, is

$y = mx - 2m - m^3$ which passes through (9, 6).

$\Rightarrow 6 = 9m - 2m - m^3$

$\Rightarrow m^3 - 7m + 6 = 0$

$\Rightarrow m = 1, 2, -3$

\therefore Equation of normals are,

$y - x + 3 = 0, y + 3x - 33 = 0$

and $y - 2x + 12 = 0$

7. Equation of tangent and normal at point $P(at^2, 2at)$ is

$ty = x + at^2$ and $y = -tx + 2at + at^3$

Let centroid of ΔPTN is $R(h, k)$.

$\therefore h = \frac{at^2 + (-at^2) + 2a + at^2}{3}$

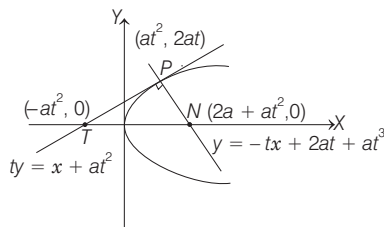

and $k = \frac{2at}{3}$

$\Rightarrow 3h = 2a + a \cdot \left(\frac{3k}{2a}\right)^2$

$\Rightarrow 3h = 2a + \frac{9k^2}{4a}$

$\Rightarrow 9k^2 = 4a(3h - 2a)$

\therefore Locus of centroid is

$$y^2 = \frac{4a}{3} \left(x - \frac{2a}{3}\right)$$

\therefore Vertex $\left(\frac{2a}{3}, 0\right)$; directrix

$$x - \frac{2a}{3} = -\frac{a}{3}$$

$\Rightarrow x = \frac{a}{3}$

and latusrectum = $\frac{4a}{3}$

\therefore Focus $\left(\frac{a}{3} + \frac{2a}{3}, 0\right)$, i.e. $(a, 0)$.

8. End points of latusrectum are $(a, \pm 2a)$ i.e. $(1, \pm 2)$.

Equation of normal at (x_1, y_1) is

$$\frac{y - y_1}{x - x_1} = -\frac{y_1}{2a}$$

i.e. $\frac{y - 2}{x - 1} = -\frac{2}{2}$ and $\frac{y + 2}{x - 1} = \frac{2}{2}$

$\Rightarrow x + y = 3$

and $x - y = 3$

which is tangent to $(x - 3)^2 + (y + 2)^2 = r^2$

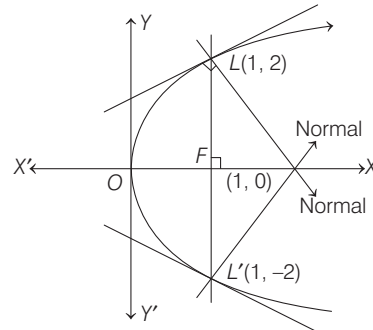

\therefore Length of perpendicular from centre = Radius

$\Rightarrow \frac{|3 - 2 - 3|}{\sqrt{1^2 + 1^2}} = r$

$\therefore r^2 = 2$

9. We know equation of normal to $y^2 = 4ax$ is

$$y = mx - 2am - am^3$$

Thus, equation of normal to $y^2 = 4x$ is,

$y = mx - 2m - m^3$, let it passes through (h, k) .

$\Rightarrow k = mh - 2m - m^3$

or $m^3 + m(2 - h) + k = 0$... (i)

Here,

$$m_1 + m_2 + m_3 = 0,$$

$$m_1 m_2 + m_2 m_3 + m_3 m_1 = 2 - h,$$

$$m_1 m_2 m_3 = -k \text{ where } m_1 m_2 = \alpha$$

$$\Rightarrow m_3 = -\frac{k}{\alpha}, \text{ it must satisfy Eq. (i)}$$

$$\Rightarrow -\frac{k^3}{\alpha^3} - \frac{k}{\alpha} (2-h) + k = 0$$

$$\Rightarrow k^2 = \alpha^2 h - 2\alpha^2 + \alpha^3$$

$$\Rightarrow y^2 = \alpha^2 x - 2\alpha^2 + \alpha^3$$

On comparing with $y^2 = 4x$

$$\Rightarrow \alpha^2 = 4 \text{ and } -2\alpha^2 + \alpha^3 = 0$$

$$\Rightarrow \alpha = 2$$

10. We know that, normal for $y^2 = 4ax$ is given by, $y = mx - 2am - am^3$.

\therefore Equation of normal for $y^2 = x$ is

$$y = mx - \frac{m}{2} - \frac{m^3}{4} \quad \left[\because a = \frac{1}{4} \right]$$

Since, normal passes through $(c, 0)$.

$$\therefore mc - \frac{m}{2} - \frac{m^3}{4} = 0$$

$$\Rightarrow m \left(c - \frac{1}{2} - \frac{m^2}{4} \right) = 0 \Rightarrow m = 0$$

or $m^2 = 4 \left(c - \frac{1}{2} \right)$

$\Rightarrow m = 0$, the equation of normal is $y = 0$

Also, $m^2 \geq 0$

$$\Rightarrow c - 1/2 \geq 0 \Rightarrow c \geq 1/2$$

At $c = 1/2 \Rightarrow m = 0$

Now, for other normals to be perpendicular to each other, we must have $m_1 \cdot m_2 = -1$

or $\frac{m^2}{4} + \left(\frac{1}{2} - c \right) = 0$, has $m_1 m_2 = -1$

$$\Rightarrow \frac{\left(\frac{1}{2} - c \right)}{1/4} = -1 \Rightarrow \frac{1}{2} - c = -\frac{1}{4}$$

$$\Rightarrow c = \frac{3}{4}$$

11. Equation of normal to $x^2 = 4y$ is $x = my - 2m - m^3$ and passing through $(1, 2)$.

$$\therefore 1 = 2m - 2m - m^3$$

$$\Rightarrow m^3 = -1 \text{ or } m = -1$$

Thus, the required equation of normal is ,

$x = -y + 2 + 1$ or $x + y = 3$ is required equation.

12. If three different normals are drawn from $(h, 0)$ to $y^2 = 4x$.

Then, equation of normals are $y = mx - 2m - m^3$ which passes through $(h, 0)$.

$$\Rightarrow mh - 2m - m^3 = 0$$

$$\Rightarrow h = 2 + m^2$$

where, $2 + m^2 \geq 2$

$$\therefore h > 2 \text{ [neglect equality as if } 2 + m^2 = 2 \Rightarrow m = 0]$$

Therefore, three normals are coincident.

$$\therefore h > 2$$

Topic 4 Diameter, Chord of Contact, Chord Bisected and Product of Pair of Tangents

1. **Key Idea** (i) First find the focus of the given parabola
 (ii) Then, find the slope of the focal chord by using $m = \frac{y_2 - y_1}{x_2 - x_1}$
 (iii) Now, find the length of the focal chord by using the formula $4a \operatorname{cosec}^2 \alpha$.

Equation of given parabola is $y^2 = 16x$, its focus is $(4, 0)$.
 Since, slope of line passing through (x_1, y_1) and (x_2, y_2) is given by $m = \tan \theta = \frac{y_2 - y_1}{x_2 - x_1}$.

\therefore Slope of focal chord having one end point is $(1, 4)$ is

$$m = \tan \alpha = \frac{4-0}{1-4} = -\frac{4}{3}$$

[where, ' α ' is the inclination of focal chord with X-axis.]

Since, the length of focal chord = $4a \operatorname{cosec}^2 \alpha$

\therefore The required length of the focal chord

$$= 16 [1 + \cot^2 \alpha] \quad [\because a = 4 \text{ and } \operatorname{cosec}^2 \alpha = 1 + \cot^2 \alpha]$$

$$= 16 \left[1 + \frac{9}{16} \right] = 25 \text{ units} \quad \left[\because \cot \alpha = \frac{1}{\tan \alpha} = -\frac{3}{4} \right]$$

2. Given, equation of parabola is $x^2 = 4y$... (i)
 and the chord is $x - \sqrt{2}y + 4\sqrt{2} = 0$... (ii)

From Eqs. (i) and (ii), we have

$$[\sqrt{2}(y-4)]^2 = 4y \Rightarrow 2(y-4)^2 = 4y$$

$$\Rightarrow (y-4)^2 = 2y \Rightarrow y^2 - 8y + 16 = 2y$$

$$\Rightarrow y^2 - 10y + 16 = 0 \quad \dots \text{(iii)}$$

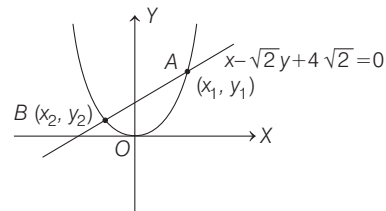

Let the roots of Eq. (iii) be y_1 and y_2

Then, $y_1 + y_2 = 10$ and $y_1 y_2 = 16$... (iv)

Again from Eqs. (i) and (ii), we have

$$x^2 = 4 \left[\frac{x}{\sqrt{2}} + 4 \right]$$

$$\Rightarrow x^2 - 2\sqrt{2}x - 16 = 0 \quad \dots \text{(v)}$$

Let the roots of Eq. (v) be x_1 and x_2

Then, $x_1 + x_2 = 2\sqrt{2}$ and $x_1 x_2 = -16$... (vi)

Clearly, length of the chord AB

$$= \sqrt{(x_1 - x_2)^2 + (y_1 - y_2)^2}$$

$$= \sqrt{(x_1 + x_2)^2 - 4x_1 x_2 + (y_1 + y_2)^2 - 4y_1 y_2}$$

$$[\because (a - b)^2 = (a + b)^2 - 4ab]$$

$$= \sqrt{8 + 64 + 100 - 64}$$

$$= \sqrt{108} = 6\sqrt{3} \quad \text{[from Eqs. (iv) and (vi)]}$$

3. Equation of chord with mid-point (h, k) .

$$T = S_1 \Rightarrow yk - 8x - 8h = k^2 - 16h$$

$$2x - \frac{yk}{4} = 2h - \frac{k^2}{4}$$

$\therefore 2x + y = p$
 $\therefore k = -4$ and $p = 2h - 4$
 where $h = 3 \Rightarrow p = 2 \times 3 - 4 = 2$

4. Here, coordinate $M = \left(\frac{t_1^2 + t_2^2}{2}, t_1 + t_2 \right)$ i.e. mid-point of chord AB .

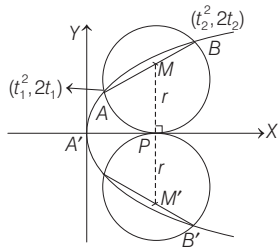

$MP = t_1 + t_2 = r$... (i)

Also, $m_{AB} = \frac{2t_2 - 2t_1}{t_2^2 - t_1^2} = \frac{2}{t_2 + t_1}$ [when AB is chord]

$\Rightarrow m_{AB} = \frac{2}{r}$ [from Eq. (i)]

Also, $m_{A'B'} = -\frac{2}{r}$ [when $A'B'$ is chord]

Hence, (c, d) are the correct options.

5. Since, $R \left[-a, a \left(t - \frac{1}{t} \right) \right]$ lies on $y = 2x + a$.

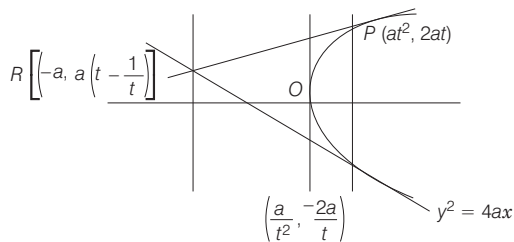

$\Rightarrow a \cdot \left(t - \frac{1}{t} \right) = -2a + a \Rightarrow t - \frac{1}{t} = -1$

Thus, length of focal chord

$= a \left(t + \frac{1}{t} \right)^2 = a \left\{ \left(t - \frac{1}{t} \right)^2 + 4 \right\} = 5a$

6. $m_{OP} = \frac{2at - 0}{at^2 - 0} = \frac{2}{t}$

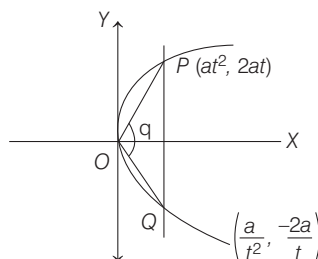

$m_{OQ} = \frac{-2at}{at^2} = -2t$

$\therefore \tan \theta = \frac{\frac{2}{t} + 2t}{1 - \frac{2}{t} \cdot 2t} = \frac{2 \left(t + \frac{1}{t} \right)}{1 - 4} = \frac{-2\sqrt{5}}{3}$

where $t + \frac{1}{t} = \sqrt{5}$

7. Let $P(\alpha, \beta)$ be any point on the locus. Equation of pair of tangents from $P(\alpha, \beta)$ to the parabola $y^2 = 4ax$

$[\beta y - 2a(x + \alpha)]^2 = (\beta^2 - 4a\alpha)(y^2 - 4ax)$
 [$\because T^2 = S \cdot S_1$]

$\Rightarrow \beta^2 y^2 + 4a^2(x^2 + \alpha^2 + 2x \cdot \alpha) - 4a\beta y(x + \alpha)$
 $= \beta^2 y^2 - 4\beta^2 ax - 4a\alpha y^2 + 16a^2 \alpha x$
 $\Rightarrow \beta^2 y^2 + 4a^2 x^2 + 4a^2 \alpha^2 + 8x\alpha a^2$
 $= \beta^2 y^2 - 4\beta^2 ax - 4a\alpha y^2 + 16a^2 \alpha x - 4a\beta xy - 4a\beta \alpha y \dots (i)$

Now, coefficient of $x^2 = 4a^2$
 coefficient of $xy = -4a\beta$
 coefficient of $y^2 = 4a\alpha$

Again, angle between the two of Eq. (i) is given as 45°

$\therefore \tan 45^\circ = \frac{2\sqrt{h^2 - ab}}{a + b}$

$\Rightarrow 1 = \frac{2\sqrt{h^2 - ab}}{a + b}$

$\Rightarrow a + b = 2\sqrt{h^2 - ab}$

$\Rightarrow (a + b)^2 = 4(h^2 - ab)$

$\Rightarrow (4a^2 + 4a\alpha)^2 = 4[4a^2\beta^2 - (4a^2)(4a\alpha)]$

$\Rightarrow 16a^2(a + \alpha)^2 = 4 \cdot 4a^2[\beta^2 - 4a\alpha]$

$\Rightarrow \alpha^2 + 6a\alpha + a^2 - \beta^2 = 0$

$\Rightarrow (\alpha + 3a)^2 - \beta^2 = 8a^2$

Thus, the required equation of the locus is $(x + 3a)^2 - y^2 = 8a^2$ which is a hyperbola.

8. Equation of any tangent to the parabola, $y^2 = 4ax$ is

$y = mx + \frac{a}{m}$

This line will touch the circle $x^2 + y^2 = \frac{a^2}{2}$

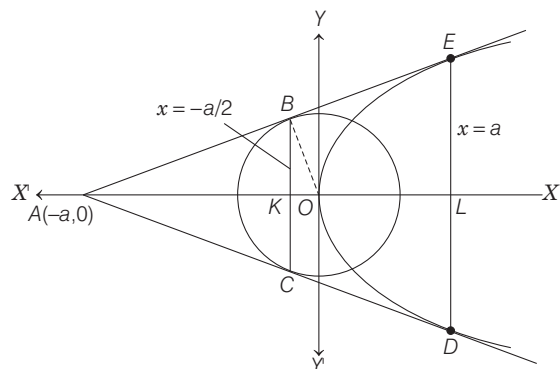

If $\left(\frac{a}{m}\right)^2 = \frac{a^2}{2}(m^2 + 1)$
 $\Rightarrow \frac{1}{m^2} = \frac{1}{2}(m^2 + 1)$
 $\Rightarrow 2 = m^4 + m^2$
 $\Rightarrow m^4 + m^2 - 2 = 0$
 $\Rightarrow (m^2 - 1)(m^2 + 2) = 0$
 $\Rightarrow m^2 - 1 = 0, m^2 = -2$
 $\Rightarrow m = \pm 1$ [$m^2 = -2$ is not possible]

Therefore, two common tangents are
 $y = x + a$ and $y = -x - a$

These two intersect at $A(-a, 0)$.

The chord of contact of $A(-a, 0)$ for the circle $x^2 + y^2 = a^2/2$ is $(-a)x + 0 \cdot y = a^2/2$

$\Rightarrow x = -a/2$

and chord of contact of $A(-a, 0)$ for the parabola $y^2 = 4ax$ is $0 \cdot y = 2a(x - a) \Rightarrow x = a$

Again, length of $BC = 2BK$
 $= 2\sqrt{OB^2 - OK^2}$
 $= 2\sqrt{\frac{a^2}{2} - \frac{a^2}{4}} = 2\sqrt{\frac{a^2}{4}} = a$

and we know that, DE is the latusrectum of the parabola, so its length is $4a$.

Thus, area of the quadrilateral $BCDE$

$$= \frac{1}{2}(BC + DE)(KL)$$

$$= \frac{1}{2}(a + 4a)\left(\frac{3a}{2}\right) = \frac{15a^2}{4}$$

9. Let the three points on the parabola be $A(at_1^2, 2at_1), B(at_2^2, 2at_2)$ and $C(at_3^2, 2at_3)$.

Equation of the tangent to the parabola at $(at^2, 2at)$ is

$$ty = x + at^2$$

Therefore, equations of tangents at A and B are

$$t_1y = x + at_1^2 \quad \dots(i)$$

and $t_2y = x + at_2^2 \quad \dots(ii)$

From Eqs. (i) and (ii)

$$\Rightarrow t_1y = t_2y - at_2^2 + at_1^2$$

$$\Rightarrow t_1y - t_2y = at_1^2 - at_2^2$$

$$\Rightarrow y = a(t_1 + t_2) \quad [\because t_1 \neq t_2]$$

and $t_1 a(t_1 + t_2) = x + at_1^2$ [from Eq. (i)]

$$\Rightarrow x = at_1t_2$$

Therefore, coordinates of P are $(at_1t_2, a(t_1 + t_2))$.

Similarly, the coordinates of Q and R are respectively,

$$[at_2t_3, a(t_2 + t_3)] \text{ and } [at_1t_3, a(t_1 + t_3)].$$

Let $\Delta_1 = \text{Area of the } \Delta ABC$

$$= \frac{1}{2} \begin{vmatrix} at_1^2 & 2at_1 & 1 \\ at_2^2 & 2at_2 & 1 \\ at_3^2 & 2at_3 & 1 \end{vmatrix}$$

Applying $R_3 \rightarrow R_3 - R_2$ and $R_2 \rightarrow R_2 - R_1$, we get

$$\Delta_1 = \frac{1}{2} \begin{vmatrix} at_1^2 & 2at_1 & 1 \\ a(t_2^2 - t_1^2) & 2a(t_2 - t_1) & 0 \\ a(t_3^2 - t_2^2) & 2a(t_3 - t_2) & 0 \end{vmatrix}$$

$$= \frac{1}{2} \begin{vmatrix} a(t_2^2 - t_1^2) & 2a(t_2 - t_1) \\ a(t_3^2 - t_2^2) & 2a(t_3 - t_2) \end{vmatrix}$$

$$= \frac{1}{2} \cdot a \cdot 2a \begin{vmatrix} (t_2 - t_1)(t_2 + t_1) & (t_2 - t_1) \\ (t_3 - t_2)(t_3 + t_2) & (t_3 - t_2) \end{vmatrix}$$

$$= a^2(t_2 - t_1)(t_3 - t_2) \begin{vmatrix} t_2 + t_1 & 1 \\ t_3 + t_2 & 1 \end{vmatrix}$$

$$= a^2|(t_2 - t_1)(t_3 - t_2)(t_1 - t_3)|$$

Again, let $\Delta_2 = \text{area of the } \Delta PQR$

$$= \frac{1}{2} \begin{vmatrix} at_1t_2 & a(t_1 + t_2) & 1 \\ at_2t_3 & a(t_2 + t_3) & 1 \\ at_3t_1 & a(t_3 + t_1) & 1 \end{vmatrix}$$

$$= \frac{1}{2} a \cdot a \begin{vmatrix} t_1t_2 & (t_1 + t_2) & 1 \\ t_2t_3 & (t_2 + t_3) & 1 \\ t_3t_1 & (t_3 + t_1) & 1 \end{vmatrix}$$

Applying $R_3 \rightarrow R_3 - R_2, R_2 \rightarrow R_2 - R_1$, we get

$$= \frac{a^2}{2} \begin{vmatrix} t_1t_2 & t_1 + t_2 & 1 \\ t_2(t_3 - t_1) & t_3 - t_1 & 0 \\ t_3(t_1 - t_2) & t_1 - t_2 & 0 \end{vmatrix}$$

$$= \frac{a^2}{2}(t_3 - t_1)(t_1 - t_2) \begin{vmatrix} t_1t_2 & t_1 + t_2 & 1 \\ t_2 & 1 & 0 \\ t_3 & 1 & 0 \end{vmatrix}$$

$$= \frac{a^2}{2}(t_3 - t_1)(t_1 - t_2) \begin{vmatrix} t_2 & 1 \\ t_3 & 1 \end{vmatrix}$$

$$= \frac{a^2}{2} |(t_3 - t_1)(t_1 - t_2)(t_2 - t_3)|$$

Therefore, $\frac{\Delta_1}{\Delta_2} = \frac{a^2|(t_2 - t_1)(t_3 - t_2)(t_1 - t_3)|}{\frac{1}{2}a^2|(t_3 - t_1)(t_1 - t_2)(t_2 - t_3)|} = 2$

10. Let $A(t_1^2, 2t_1)$ and $B(t_2^2, 2t_2)$ be coordinates of the end points of a chord of the parabola $y^2 = 4x$ having slope 2.

Now, slope of AB is

$$m = \frac{2t_2 - 2t_1}{t_2^2 - t_1^2} = \frac{2(t_2 - t_1)}{(t_2 - t_1)(t_2 + t_1)} = \frac{2}{t_2 + t_1}$$

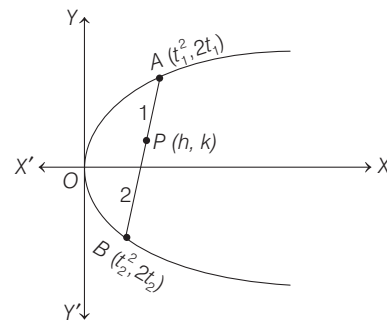

But $m = 2$ [given]

$$\Rightarrow 2 = \frac{2}{t_2 + t_1}$$

$$\Rightarrow t_1 + t_2 = 1 \quad \dots(i)$$

Let $P(h, k)$ be a point on AB such that, it divides AB internally in the ratio 1 : 2.

$$\text{Then, } h = \frac{2t_1^2 + t_2^2}{2 + 1} \text{ and } k = \frac{2(2t_1) + 2t_2}{2 + 1}$$

$$\Rightarrow 3h = 2t_1^2 + t_2^2 \quad \dots(ii)$$

$$\text{and } 3k = 4t_1 + 2t_2 \quad \dots(iii)$$

On substituting value of t_1 from Eq. (i) in Eq. (iii)

$$3k = 4(1 - t_2) + 2t_2$$

$$\Rightarrow 3k = 4 - 2t_2$$

$$\Rightarrow t_2 = 2 - \frac{3k}{2} \quad \dots(iv)$$

On substituting $t_1 = 1 - t_2$ in Eq. (ii), we get

$$\begin{aligned} 3h &= 2(1 - t_2)^2 + t_2^2 \\ &= 2(1 - 2t_2 + t_2^2) + t_2^2 \\ &= 3t_2^2 - 4t_2 + 2 = 3\left(t_2^2 - \frac{4}{3}t_2 + \frac{2}{3}\right) \end{aligned}$$

$$= 3\left[\left(t_2 - \frac{2}{3}\right)^2 + \frac{2}{3} - \frac{4}{9}\right]$$

$$= 3\left(t_2 - \frac{2}{3}\right)^2 + \frac{2}{3}$$

$$\Rightarrow 3h - \frac{2}{3} = 3\left(t_2 - \frac{2}{3}\right)^2$$

$$\Rightarrow 3\left(h - \frac{2}{9}\right) = 3\left(2 - \frac{3k}{2} - \frac{2}{3}\right)^2 \quad [\text{from Eq. (iv)}]$$

$$\Rightarrow 3\left(h - \frac{2}{9}\right) = 3\left(\frac{4}{3} - \frac{3k}{2}\right)^2$$

$$\Rightarrow \left(h - \frac{2}{9}\right) = \frac{9}{4}\left(k - \frac{8}{9}\right)^2$$

$$\Rightarrow \left(k - \frac{8}{9}\right)^2 = \frac{4}{9}\left(h - \frac{2}{9}\right)$$

On generalising, we get the required locus

$$\left(y - \frac{8}{9}\right)^2 = \frac{4}{9}\left(x - \frac{2}{9}\right)$$

This represents a parabola with vertex at $\left(\frac{2}{9}, \frac{8}{9}\right)$.

11. Let the equation of chord OP be $y = mx$.

Then, equation of chord will be $y = -\frac{1}{m}x$ and

P is point of intersection of $y = mx$ and $y^2 = 4x$ is

$\left(\frac{4}{m^2}, \frac{4}{m}\right)$ and Q is point intersection of $y = -\frac{1}{m}x$ and

$y^2 = 4x$ is $(4m^2, -4m)$.

Now, equation of PQ is

$$y + 4m = \frac{\frac{4}{m} + 4m}{\frac{4}{m^2} - 4m^2}(x - 4m^2)$$

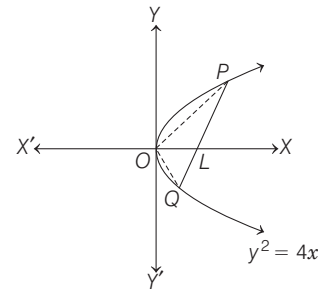

$$\Rightarrow y + 4m = \frac{m}{1 - m^2}(x - 4m^2)$$

$$\Rightarrow (1 - m^2)y + 4m - 4m^3 = mx - 4m^3$$

$$\Rightarrow mx - (1 - m^2)y - 4m = 0$$

This line meets X -axis, where $y = 0$

i.e. $x = 4 \Rightarrow OL = 4$ which is constant as independent of m .

Again, let (h, k) be the mid-point of PQ . Then,

$$h = \frac{4m^2 + \frac{4}{m^2}}{2}$$

$$\text{and } k = \frac{\frac{4}{m} - 4m}{2}$$

$$\Rightarrow h = 2\left(m^2 + \frac{1}{m^2}\right)$$

$$\text{and } k = 2\left(\frac{1}{m} - m\right)$$

$$\Rightarrow h = 2\left[\left(m - \frac{1}{m}\right)^2 + 2\right]$$

$$\text{and } k = 2\left(\frac{1}{m} - m\right)$$

Eliminating m , we get

$$2h = k^2 + 8$$

or $y^2 = 2(x - 4)$ is required equation of locus.

18

Ellipse

Topic 1 Equation of Ellipse and Focal Chord

Objective Questions I (Only one correct option)

- If e_1 and e_2 are the eccentricities of the ellipse, $\frac{x^2}{18} + \frac{y^2}{4} = 1$ and the hyperbola, $\frac{x^2}{9} - \frac{y^2}{4} = 1$ respectively and (e_1, e_2) is a point on the ellipse, $15x^2 + 3y^2 = k$, then k is equal to
(2020 Main, 9 Jan II)
(a) 14 (b) 15 (c) 17 (d) 16
- An ellipse, with foci at $(0, 2)$ and $(0, -2)$ and minor axis of length 4, passes through which of the following points?
(2019 Main, 12 April II)
(a) $(\sqrt{2}, 2)$ (b) $(2, \sqrt{2})$
(c) $(2, 2\sqrt{2})$ (d) $(1, 2\sqrt{2})$
- In an ellipse, with centre at the origin, if the difference of the lengths of major axis and minor axis is 10 and one of the foci is at $(0, 5\sqrt{3})$, then the length of its latus rectum is
(2019 Main, 8 April I)
(a) 5 (b) 10 (c) 8 (d) 6
- Let S and S' be the foci of an ellipse and B be any one of the extremities of its minor axis. If $\Delta S'BS$ is a right angled triangle with right angle at B and area $(\Delta S'BS) = 8$ sq units, then the length of a latus rectum of the ellipse is
(2019 Main, 12 Jan II)
(a) $2\sqrt{2}$ (b) $4\sqrt{2}$
(c) 2 (d) 4
- Let the length of the latus rectum of an ellipse with its major axis along X-axis and centre at the origin, be 8. If the distance between the foci of this ellipse is equal to the length of its minor axis, then which one of the following points lies on it?
(2019 Main, 11 Jan II)
(a) $(4\sqrt{2}, 2\sqrt{3})$ (b) $(4\sqrt{3}, 2\sqrt{2})$
(c) $(4\sqrt{2}, 2\sqrt{2})$ (d) $(4\sqrt{3}, 2\sqrt{3})$
- The equation of the circle passing through the foci of the ellipse $\frac{x^2}{16} + \frac{y^2}{9} = 1$ and having centre at $(0, 3)$ is
(2013 Main)
(a) $x^2 + y^2 - 6y - 7 = 0$
(b) $x^2 + y^2 - 6y + 7 = 0$
(c) $x^2 + y^2 - 6y - 5 = 0$
(d) $x^2 + y^2 - 6y + 5 = 0$

- The ellipse $E_1 : \frac{x^2}{9} + \frac{y^2}{4} = 1$ is inscribed in a rectangle R whose sides are parallel to the coordinate axes. Another ellipse E_2 passing through the point $(0, 4)$ circumscribes the rectangle R . The eccentricity of the ellipse E_2 is
(2012)
(a) $\frac{\sqrt{2}}{2}$ (b) $\frac{\sqrt{3}}{2}$ (c) $\frac{1}{2}$ (d) $\frac{3}{4}$
- If $P = (x, y)$, $F_1 = (3, 0)$, $F_2 = (-3, 0)$ and $16x^2 + 25y^2 = 400$, then $PF_1 + PF_2$ equals (1998, 2M)
(a) 8 (b) 6 (c) 10 (d) 12

Objective Questions II

(One or more than one correct option)

- Define the collections $\{E_1, E_2, E_3, \dots\}$ of ellipses and $\{R_1, R_2, R_3, \dots\}$ of rectangles as follows :
 $E_1 : \frac{x^2}{9} + \frac{y^2}{4} = 1$
 R_1 : rectangle of largest area, with sides parallel to the axes, inscribed in E_1 ;
 E_n : ellipse $\frac{x^2}{a_n^2} + \frac{y^2}{b_n^2} = 1$ of the largest area inscribed in R_{n-1} , $n > 1$;
 R_n : rectangle of largest area, with sides parallel to the axes, inscribed in E_n , $n > 1$.
Then which of the following options is/are correct?
(2019 Adv.)
(a) The eccentricities of E_{18} and E_{19} are NOT equal.
(b) The distance of a focus from the centre in E_9 is $\frac{\sqrt{5}}{32}$.
(c) $\sum_{n=1}^N (\text{area of } R_n) < 24$, for each positive integer N .
(d) The length of latusrectum of E_9 is $\frac{1}{6}$
- Consider two straight lines, each of which is tangent to both the circle $x^2 + y^2 = (1/2)$ and the parabola $y^2 = 4x$. Let these lines intersect at the point Q . Consider the ellipse whose centre is at the origin $O(0, 0)$ and whose semi-major axis is OQ . If the length of the minor axis of

this ellipse is $\sqrt{2}$, then which of the following statement(s) is (are) TRUE? (2018 Adv.)

- (a) For the ellipse, the eccentricity is $1/\sqrt{2}$ and the length of the latus rectum is 1
- (b) For the ellipse, the eccentricity is $1/2$ and the length of the latus rectum is $1/2$
- (c) The area of the region bounded by the ellipse between the lines $x = \frac{1}{\sqrt{2}}$ and $x=1$ is $\frac{1}{4\sqrt{2}}(\pi - 2)$
- (d) The area of the region bounded by the ellipse between the lines $x = \frac{1}{\sqrt{2}}$ and $x=1$ is $\frac{1}{16}(\pi - 2)$

Fill in the Blanks

- 11. An ellipse has OB as a semi-minor axis. F and F' are its foci and the angle FBF' is a right angle. Then, the eccentricity of the ellipse is (1997, 2M)
- 12. An ellipse has eccentricity $\frac{1}{2}$ and one focus at the point $P\left(\frac{1}{2}, 1\right)$. Its one directrix is the common tangent, nearer to the point P , to the circle $x^2 + y^2 = 1$ and the hyperbola $x^2 - y^2 = 1$. The equation of the ellipse, in the standard form is..... (1996, 2M)
- 13. Let P be a variable point on the ellipse $\frac{x^2}{a^2} + \frac{y^2}{b^2} = 1$ with foci F_1 and F_2 . If A is the area of the ΔPF_1F_2 , then the maximum value of A is... (1994, 2M)

Topic 2: Equation of Tangent and Normal

- 1. Let a, b and λ be positive real numbers. Suppose P is an end point of the latus rectum of the parabola $y^2 = 4\lambda x$, and suppose the ellipse $\frac{x^2}{a^2} + \frac{y^2}{b^2} = 1$ passes through the point P . If the tangents to the parabola and the ellipse at the point P are perpendicular to each other, then the eccentricity of the ellipse is (2020 Adv.)
 (a) $\frac{1}{\sqrt{2}}$ (b) $\frac{1}{2}$ (c) $\frac{1}{3}$ (d) $\frac{2}{5}$
- 2. Which of the following points lies on the locus of the foot of perpendicular drawn upon any tangent to the ellipse, $\frac{x^2}{4} + \frac{y^2}{2} = 1$ from any of its foci? (2020 Main, 6 Sep I)
 (a) $(-2, \sqrt{3})$ (b) $(-1, \sqrt{2})$
 (c) $(-1, \sqrt{3})$ (d) $(1, 2)$
- 3. If the normal to the ellipse $3x^2 + 4y^2 = 12$ at a point P on it is parallel to the line, $2x + y = 4$ and the tangent to the ellipse at P passes through $Q(4, 4)$ then PQ is equal to (2019 Main, 12 April I)
 (a) $\frac{5\sqrt{5}}{2}$ (b) $\frac{\sqrt{61}}{2}$ (c) $\frac{\sqrt{221}}{2}$ (d) $\frac{\sqrt{157}}{2}$

Analytical & Descriptive Question

14. Let P be a point on the ellipse $\frac{x^2}{a^2} + \frac{y^2}{b^2} = 1, 0 < b < a$.

Let the line parallel to Y -axis passing through P meet the circle $x^2 + y^2 = a^2$ at the point Q such that P and Q are on the same side of X -axis. For two positive real numbers r and s , find the locus of the point R on PQ such that $PR:RQ = r:s$ as P varies over the ellipse. (2001, 4M)

Passage Type Questions

Passage

Let $F_1(x_1, 0)$ and $F_2(x_2, 0)$, for $x_1 < 0$ and $x_2 > 0$, be the foci of the ellipse $\frac{x^2}{9} + \frac{y^2}{8} = 1$. Suppose a parabola having vertex at the origin and focus at F_2 intersects the ellipse at point M in the first quadrant and at point N in the fourth quadrant. (2016 Adv.)

- 15. The orthocentre of ΔF_1MN is
 (a) $\left(-\frac{9}{10}, 0\right)$ (b) $\left(\frac{2}{3}, 0\right)$
 (c) $\left(\frac{9}{10}, 0\right)$ (d) $\left(\frac{2}{3}, \sqrt{6}\right)$
- 16. If the tangents to the ellipse at M and N meet at R and the normal to the parabola at M meets the X -axis at Q , then the ratio of area of ΔMQR to area of the quadrilateral MF_1NF_2 is
 (a) $3:4$ (b) $4:5$ (c) $5:8$ (d) $2:3$

- 4. The tangent and normal to the ellipse $3x^2 + 5y^2 = 32$ at the point $P(2, 2)$ meets the X -axis at Q and R , respectively. Then, the area (in sq units) of the ΔPQR is (2019 Main, 10 April II)
 (a) $\frac{16}{3}$ (b) $\frac{14}{3}$ (c) $\frac{34}{15}$ (d) $\frac{68}{15}$
- 5. If the line $x - 2y = 12$ is tangent to the ellipse $\frac{x^2}{a^2} + \frac{y^2}{b^2} = 1$ at the point $\left(3, \frac{-9}{2}\right)$, then the length of the latusrectum of the ellipse is (2019 Main, 10 April I)
 (a) $8\sqrt{3}$ (b) 9 (c) 5
 (d) $12\sqrt{2}$
- 6. If the tangent to the parabola $y^2 = x$ at a point (α, β) , ($\beta > 0$) is also a tangent to the ellipse, $x^2 + 2y^2 = 1$, then α is equal to (2019 Main, 9 April II)
 (a) $\sqrt{2} + 1$ (b) $\sqrt{2} - 1$ (c) $2\sqrt{2} + 1$ (d) $2\sqrt{2} - 1$
- 7. If the tangents on the ellipse $4x^2 + y^2 = 8$ at the points $(1, 2)$ and (a, b) are perpendicular to each other, then a^2 is equal to (2019 Main, 8 April I)
 (a) $\frac{128}{17}$ (b) $\frac{64}{17}$ (c) $\frac{4}{17}$ (d) $\frac{2}{17}$

460 Ellipse

8. If tangents are drawn to the ellipse $x^2 + 2y^2 = 2$ at all points on the ellipse other than its four vertices, then the mid-points of the tangents intercepted between the coordinate axes lie on the curve (2019 Main, 11 Jan I)
- (a) $\frac{x^2}{4} + \frac{y^2}{2} = 1$ (b) $\frac{1}{4x^2} + \frac{1}{2y^2} = 1$
 (c) $\frac{x^2}{2} + \frac{y^2}{4} = 1$ (d) $\frac{1}{2x^2} + \frac{1}{4y^2} = 1$
9. Equation of a common tangent to the parabola $y^2 = 4x$ and the hyperbola $xy = 2$ is (2019 Main, 11 Jan I)
- (a) $x + 2y + 4 = 0$ (b) $x - 2y + 4 = 0$
 (c) $4x + 2y + 1 = 0$ (d) $x + y + 1 = 0$
10. The eccentricity of an ellipse whose centre is at the origin is $1/2$. If one of its directrices is $x = -4$, then the equation of the normal to it at $\left(1, \frac{3}{2}\right)$ is (2017 Main)
- (a) $2y - x = 2$ (b) $4x - 2y = 1$
 (c) $4x + 2y = 7$ (d) $x + 2y = 4$
11. The area (in sq units) of the quadrilateral formed by the tangents at the end points of the latusrectum to the ellipse $\frac{x^2}{9} + \frac{y^2}{5} = 1$ is (2015 Main)
- (a) $\frac{27}{4}$ (b) 18 (c) $\frac{27}{2}$ (d) 27
12. The locus of the foot of perpendicular drawn from the centre of the ellipse $x^2 + 3y^2 = 6$ on any tangent to it is (2014 Main)
- (a) $(x^2 - y^2)^2 = 6x^2 + 2y^2$
 (b) $(x^2 - y^2)^2 = 6x^2 - 2y^2$
 (c) $(x^2 + y^2)^2 = 6x^2 + 2y^2$
 (d) $(x^2 + y^2)^2 = 6x^2 - 2y^2$
13. The normal at a point P on the ellipse $x^2 + 4y^2 = 16$ meets the X -axis at Q . If M is the mid-point of the line segment PQ , then the locus of M intersects the latusrectum of the given ellipse at the points (2009)
- (a) $\left(\pm \frac{3\sqrt{5}}{2}, \pm \frac{2}{7}\right)$ (b) $\left(\pm \frac{3\sqrt{5}}{2}, \pm \frac{\sqrt{19}}{4}\right)$
 (c) $\left(\pm 2\sqrt{3}, \pm \frac{1}{7}\right)$ (d) $\left(\pm 2\sqrt{3}, \pm \frac{4\sqrt{3}}{7}\right)$
14. The line passing through the extremity A of the major axis and extremity B of the minor axis of the ellipse $x^2 + 9y^2 = 9$ meets its auxiliary circle at the point M . Then, the area (insquants) of the triangle with vertices at A, M and the origin O is (2009)
- (a) $\frac{31}{10}$ (b) $\frac{29}{10}$
 (c) $\frac{21}{10}$ (d) $\frac{27}{10}$
15. Tangents are drawn to the ellipse $x^2 + 2y^2 = 2$, then the locus of the mid-point of the intercept made by the tangents between the coordinate axes is (2004, 1M)
- (a) $\frac{1}{2x^2} + \frac{1}{4y^2} = 1$ (b) $\frac{1}{4x^2} + \frac{1}{2y^2} = 1$
 (c) $\frac{x^2}{2} + \frac{y^2}{4} = 1$ (d) $\frac{x^2}{4} + \frac{y^2}{2} = 1$

16. Tangent is drawn to ellipse $\frac{x^2}{27} + y^2 = 1$ at $(3\sqrt{3}\cos\theta, \sin\theta)$ (where, $\theta \in (0, \pi/2)$). Then, the value of θ such that the sum of intercepts on axes made by this tangent is minimum, is (2003, 1M)
- (a) $\frac{\pi}{3}$ (b) $\frac{\pi}{6}$ (c) $\frac{\pi}{8}$ (d) $\frac{\pi}{4}$
17. If $a > 2b > 0$, then positive value of m for which $y = mx - b\sqrt{1 + m^2}$ is a common tangent to $x^2 + y^2 = b^2$ and $(x - a)^2 + y^2 = b^2$ is (2002, 1M)
- (a) $\frac{2b}{\sqrt{a^2 - 4b^2}}$ (b) $\frac{\sqrt{a^2 - 4b^2}}{2b}$
 (c) $\frac{2b}{a - 2b}$ (d) $\frac{b}{a - 2b}$
18. The number of values of c such that the straight line $y = 4x + c$ touches the curve $\frac{x^2}{4} + y^2 = 1$ is (1998, 2M)
- (a) 0 (b) 2 (c) 1 (d) ∞

Objective Question II

(One or more than one correct option)

19. Let E_1 and E_2 be two ellipses whose centres are at the origin. The major axes of E_1 and E_2 lie along the X -axis and Y -axis, respectively. Let S be the circle $x^2 + (y - 1)^2 = 2$. The straight line $x + y = 3$ touches the curves S, E_1 and E_2 at P, Q and R , respectively. Suppose that $PQ = PR = \frac{2\sqrt{2}}{3}$. If e_1 and e_2 are the eccentricities of E_1 and E_2 respectively, then the correct expression(s) is/are (2015 Adv.)
- (a) $e_1^2 + e_2^2 = \frac{43}{40}$ (b) $e_1 e_2 = \frac{\sqrt{7}}{2\sqrt{10}}$
 (c) $|e_1^2 - e_2^2| = \frac{5}{8}$ (d) $e_1 e_2 = \frac{\sqrt{3}}{4}$

Analytical & Descriptive Questions

20. Find the equation of the common tangent in 1st quadrant to the circle $x^2 + y^2 = 16$ and the ellipse $\frac{x^2}{25} + \frac{y^2}{4} = 1$. Also, find the length of the intercept of the tangent between the coordinate axes. (2005, 4M)
21. Prove that, in an ellipse, the perpendicular from a focus upon any tangent and the line joining the centre of the ellipse of the point of contact meet on the corresponding directrix. (2002, 5M)
22. Let ABC be an equilateral triangle inscribed in the circle $x^2 + y^2 = a^2$. Suppose perpendiculars from A, B, C to the major axis of the ellipse $\frac{x^2}{a^2} + \frac{y^2}{b^2} = 1, (a > b)$ meet the ellipse respectively at P, Q, R so that P, Q, R lie on the same side of the major axis as A, B, C respectively. Prove that, the normals to the ellipse drawn at the points P, Q and R are concurrent. (2000, 7M)

23. A tangent to the ellipse $x^2 + 4y^2 = 4$ meets the ellipse $x^2 + 2y^2 = 6$ at P and Q . Prove that the tangents at P and Q of the ellipse $x^2 + 2y^2 = 6$ are at right angles.

(1997, 5M)

24. Let d be the perpendicular distance from the centre of the ellipse $x^2/a^2 + y^2/b^2 = 1$ to the tangent drawn at a point P on the ellipse. If F_1 and F_2 are the two foci of the ellipse, then show that

$$(PF_1 - PF_2)^2 = 4a^2 \left(1 - \frac{b^2}{d^2}\right) \quad (1995, 5M)$$

Integer & Numerical Answer Type Question

25. Suppose that the foci of the ellipse $\frac{x^2}{9} + \frac{y^2}{5} = 1$ are $(f_1, 0)$

and $(f_2, 0)$, where $f_1 > 0$ and $f_2 < 0$. Let P_1 and P_2 be two parabolas with a common vertex at $(0, 0)$ with foci at $(f_1, 0)$ and $(2f_2, 0)$, respectively. Let T_1 be a tangent to P_1 which passes through $(2f_2, 0)$ and T_2 be a tangent to P_2 which passes through $(f_1, 0)$. If m_1 is the slope of T_1 and

m_2 is the slope of T_2 , then the value of $\left(\frac{1}{m_1^2} + m_2^2\right)$ is

(2015 Adv.)

Topic 3 Equation of Chord of Contact, Chord Bisected at a Given Point and Diameter

Passage Based Questions

Passage

Tangents are drawn from the point $P(3, 4)$ to the ellipse $\frac{x^2}{9} + \frac{y^2}{4} = 1$ touching the ellipse at points A and B . (2010)

1. The equation of the locus of the point whose distance from the point P and the line AB are equal, is

- (a) $9x^2 + y^2 - 6xy - 54x - 62y + 241 = 0$
- (b) $x^2 + 9y^2 + 6xy - 54x + 62y - 241 = 0$
- (c) $9x^2 + 9y^2 - 6xy - 54x - 62y - 241 = 0$
- (d) $x^2 + y^2 - 2xy + 27x + 31y - 120 = 0$

2. The orthocentre of the ΔPAB is

- (a) $\left(5, \frac{8}{7}\right)$
- (b) $\left(\frac{7}{5}, \frac{25}{8}\right)$
- (c) $\left(\frac{11}{5}, \frac{8}{5}\right)$
- (d) $\left(\frac{8}{25}, \frac{7}{5}\right)$

3. The coordinates of A and B are

- (a) $(3, 0)$ and $(0, 2)$
- (b) $\left(-\frac{8}{5}, \frac{2\sqrt{161}}{15}\right)$ and $\left(-\frac{9}{5}, \frac{8}{5}\right)$
- (c) $\left(-\frac{8}{5}, \frac{2\sqrt{161}}{15}\right)$ and $(0, 2)$
- (d) $(3, 0)$ and $\left(-\frac{9}{5}, \frac{8}{5}\right)$

Answers

Topic 1

- 1. (d)
- 2. (a)
- 3. (a)
- 4. (d)
- 5. (b)
- 6. (a)
- 7. (c)
- 8. (c)
- 9. (c,d)
- 10. (a, c)

11. $e = 1/\sqrt{2}$

12. $\frac{\left(x - \frac{1}{3}\right)^2}{1/9} + \frac{(y-1)^2}{1/12} = 1$

13. $b\sqrt{a^2 - b^2}$

14. $\frac{x^2}{a^2} + \frac{y^2(r+s)^2}{(ar+bs)^2} = 1$

15. (a)

16. (c)

Topic 2

- 1. (a)
- 2. (c)
- 3. (a)
- 4. (d)
- 5. (b)
- 6. (a)
- 7. (d)
- 8. (d)
- 9. (a)
- 10. (b)
- 11. (d)
- 12. (c)
- 13. (c)
- 14. (d)
- 15. (a)
- 16. (b)
- 17. (a)
- 18. (b)
- 19. (a, b)
- 20. $y = -\frac{2x}{\sqrt{3}} + 4\sqrt{\frac{7}{3}}, \frac{14\sqrt{3}}{3}$
- 25. (4)

Topic 3

- 1. (a)
- 2. (c)
- 3. (d)

Hints & Solutions

Topic 1 Equation of Ellipse and Focal Chord

1. It is given that e_1 is the eccentricity of the ellipse, $\frac{x^2}{18} + \frac{y^2}{4} = 1$, so

$$e_1 = \sqrt{1 - \frac{4}{18}} = \sqrt{\frac{14}{18}} = \sqrt{\frac{7}{9}}$$

and e_2 is the eccentricity of the hyperbola,

$$\frac{x^2}{9} - \frac{y^2}{4} = 1, \text{ so } e_2 = \sqrt{1 + \frac{4}{9}} = \sqrt{\frac{13}{9}}$$

Now, as $(e_1, e_2) = \left(\sqrt{\frac{7}{9}}, \sqrt{\frac{13}{9}}\right)$ is a point on the ellipse,

$15x^2 + 3y^2 = k$, then

$$15\left(\frac{7}{9}\right) + 3\left(\frac{13}{9}\right) = k$$

$$\Rightarrow \frac{105 + 39}{9} = k$$

$$\Rightarrow \frac{144}{9} = k \Rightarrow k = 16$$

Hence, option (d) is correct.

2. Let the equation of ellipse be

$$\frac{x^2}{a^2} + \frac{y^2}{b^2} = 1 \quad \dots(i)$$

Since, foci are at $(0, 2)$ and $(0, -2)$, major axis is along the Y -axis.

So, $be = 2$... (ii)

[where e is the eccentricity of ellipse]

and $2a = \text{length of minor axis} = 4$ [given]

$\Rightarrow a = 2$... (iii)

$$\therefore e^2 = 1 - \frac{a^2}{b^2}$$

$$\therefore \left(\frac{2}{b}\right)^2 = 1 - \frac{4}{b^2} \quad \left[\because e = \frac{2}{b}\right]$$

$$\Rightarrow \frac{8}{b^2} = 1 \Rightarrow b^2 = 8$$

Thus, equation of required ellipse is $\frac{x^2}{4} + \frac{y^2}{8} = 1$

Now, from the option the ellipse $\frac{x^2}{4} + \frac{y^2}{8} = 1$ passes through the point $(\sqrt{2}, 2)$.

3. One of the focus of ellipse $\frac{x^2}{a^2} + \frac{y^2}{b^2} = 1$ is on Y -axis

$(0, 5\sqrt{3})$

$$\therefore be = 5\sqrt{3} \quad \dots(i)$$

[where e is eccentricity of ellipse]

According to the question,

$$2b - 2a = 10$$

$$\Rightarrow b - a = 5 \quad \dots(ii)$$

On squaring Eq. (i) both sides, we get

$$b^2 e^2 = 75$$

$$\Rightarrow b^2 \left(1 - \frac{a^2}{b^2}\right) = 75 \quad \left[\because e^2 = 1 - \frac{a^2}{b^2}\right]$$

$$\Rightarrow b^2 - a^2 = 75$$

$$\Rightarrow (b + a)(b - a) = 75$$

$$\Rightarrow b + a = 15 \quad \text{[from Eq. (ii)]} \quad \dots(iii)$$

On solving Eqs. (ii) and (iii), we get

$$b = 10 \quad \text{and} \quad a = 5$$

So, length of latusrectum is $\frac{2a^2}{b} = \frac{2 \times 25}{10} = 5$ units

4. Let the ellipse be $\frac{x^2}{a^2} + \frac{y^2}{b^2} = 1$.

Then, according to given information, we have the following figure.

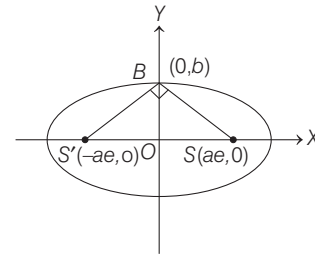

Clearly, slope of line $SB = \frac{b}{-ae}$ and slope of line $S'B = \frac{b}{ae}$

\therefore Lines SB and $S'B$ are perpendicular, so

$$\left(\frac{b}{-ae}\right) \cdot \left(\frac{b}{ae}\right) = -1$$

[\because product of slopes of two perpendicular lines is (-1)]

$$\Rightarrow b^2 = a^2 e^2 \quad \dots(i)$$

Also, it is given that area of $\Delta S'BS = 8$

$$\therefore \frac{1}{2} a^2 = 8$$

[$\because S'B = SB = a$ because $S'B + SB = 2a$ and $S'B = SB$]

$$\Rightarrow a^2 = 16 \Rightarrow a = 4 \quad \dots(ii)$$

$$\therefore e^2 = 1 - \frac{b^2}{a^2} = 1 - e^2 \quad \text{[from Eq. (i)]}$$

$$\Rightarrow 2e^2 = 1 \Rightarrow e^2 = \frac{1}{2} \quad \dots(iii)$$

From Eqs. (i) and (iii), we get

$$b^2 = a^2 \left(\frac{1}{2}\right) = 16 \left(\frac{1}{2}\right) \quad \text{[using Eq. (ii)]}$$

$$\Rightarrow b^2 = 8$$

Now, length of latus rectum = $\frac{2b^2}{a} = \frac{2 \times 8}{4} = 4$ units

5. Let the equation of ellipse be $\frac{x^2}{a^2} + \frac{y^2}{b^2} = 1$

Then, according to the problem, we have

$$\frac{2b^2}{a} = 8 \text{ and } 2ae = 2b$$

$$\text{[Length of latusrectum} = \frac{2b^2}{a} \text{ and}$$

$$\text{length of minor axis} = 2b]$$

$$\Rightarrow b \left(\frac{b}{a} \right) = 4 \text{ and } \frac{b}{a} = e$$

$$\Rightarrow b(e) = 4$$

$$\Rightarrow b = 4 \cdot \frac{1}{e}$$

...(i)

Also, we know that $b^2 = a^2(1 - e^2)$

$$\Rightarrow \frac{b^2}{a^2} = 1 - e^2 \Rightarrow e^2 = 1 - \frac{b^2}{a^2} \quad \left[\because \frac{b}{a} = e \right]$$

$$\Rightarrow 2e^2 = 1$$

$$\Rightarrow e = \frac{1}{\sqrt{2}}$$

...(ii)

From Eqs. (i) and (ii), we get

$$b = 4\sqrt{2}$$

$$\text{Now, } a^2 = \frac{b^2}{1 - e^2} = \frac{32}{1 - \frac{1}{2}} = 64$$

$$\therefore \text{Equation of ellipse be } \frac{x^2}{64} + \frac{y^2}{32} = 1$$

Now, check all the options.

Only $(4\sqrt{3}, 2\sqrt{2})$, satisfy the above equation.

6. Given equation of ellipse is $\frac{x^2}{16} + \frac{y^2}{9} = 1$

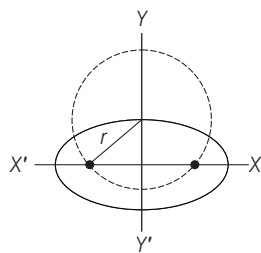

$$\text{Here, } a = 4, b = 3, e = \sqrt{1 - \frac{9}{16}}$$

$$\Rightarrow \frac{\sqrt{7}}{4}$$

$$\therefore \text{Foci} = (\pm ae, 0) = \left(\pm 4 \times \frac{\sqrt{7}}{4}, 0 \right) = (\pm \sqrt{7}, 0)$$

$$\text{Radius of the circle, } r = \sqrt{(ae)^2 + b^2} = \sqrt{7 + 9} = \sqrt{16} = 4$$

Now, equation of circle is

$$(x - 0)^2 + (y - 3)^2 = 16$$

$$\therefore x^2 + y^2 - 6y - 7 = 0$$

7. **PLAN** Equation of an ellipse is $\frac{x^2}{a^2} + \frac{y^2}{b^2} = 1$ [$\because a > b$]

Eccentricity, $e^2 = 1 - \frac{b^2}{a^2}$ [$\because a > b$]

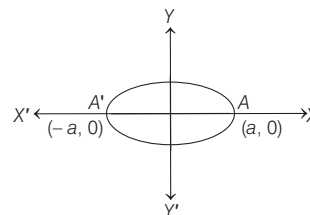

Description Situation As ellipse circumscribes the rectangle, then it must pass through all four vertices.

Let the equation of an ellipse E_2 be

$$\frac{x^2}{a^2} + \frac{y^2}{b^2} = 1, \text{ where } a < b \text{ and } b = 4.$$

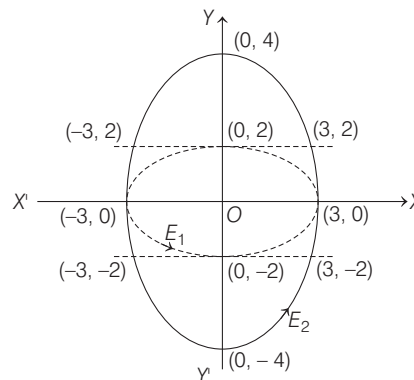

Also, it passes through $(3, 2)$.

$$\Rightarrow \frac{9}{a^2} + \frac{4}{b^2} = 1 \quad [\because b = 4]$$

$$\Rightarrow \frac{9}{a^2} + \frac{1}{4} = 1 \text{ or } a^2 = 12$$

Eccentricity of E_2 , $e^2 = 1 - \frac{a^2}{b^2} = 1 - \frac{12}{16} = \frac{1}{4}$ [$\because a < b$]

$$\therefore e = \frac{1}{2}$$

8. Given, $16x^2 + 25y^2 = 400$ [given]

$$\Rightarrow \frac{x^2}{25} + \frac{y^2}{16} = 1$$

Now, $PF_1 + PF_2 = \text{Major axis} = 2a$ [where, $a = 5$]
 $= 2 \times 5 = 10$

9. Given equation of ellipse

$$E_1 : \frac{x^2}{9} + \frac{y^2}{4} = 1 \quad \dots(i)$$

Now, let a vertex of rectangle of largest area with sides parallel to the axes, inscribed in E_1 be $(3 \cos \theta, 2 \sin \theta)$.

So, area of rectangle $R_1 = 2(3 \cos \theta) \times 2(2 \sin \theta)$
 $= 12 \sin(2\theta)$

464 Ellipse

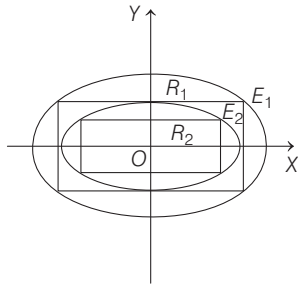

The area of R_1 will be maximum, if $\theta = \frac{\pi}{4}$ and maximum area is 12 square units and length of sides of rectangle R_1 are $2a \cos \theta = \sqrt{2} a = 3\sqrt{2}$ = length of major axis of ellipse E_2 and $2b \sin \theta = \sqrt{2} b = 2\sqrt{2}$ = length of minor axis of ellipse E_2 .

So, $E_2: \frac{x^2}{\left(\frac{a}{\sqrt{2}}\right)^2} + \frac{y^2}{\left(\frac{b}{\sqrt{2}}\right)^2} = 1$ and maximum area of

rectangle $R_2 = 2 \left(\frac{a}{\sqrt{2}}\right) \left(\frac{b}{\sqrt{2}}\right)$ and so on.

So, $E_n: \frac{x^2}{\left(\frac{a}{(\sqrt{2})^{n-1}}\right)^2} + \frac{y^2}{\left(\frac{b}{(\sqrt{2})^{n-1}}\right)^2} = 1$, and maximum

area of rectangle $R_n = 2 \left(\frac{a}{(\sqrt{2})^{n-1}}\right) \left(\frac{b}{(\sqrt{2})^{n-1}}\right)$

Now option (a),

Since, eccentricity of ellipse $E_n = e_n = \sqrt{1 - \frac{(b_n)^2}{(a_n)^2}}$

$$= \sqrt{1 - \frac{\left(\frac{b}{(\sqrt{2})^{n-1}}\right)^2}{\left(\frac{a}{(\sqrt{2})^{n-1}}\right)^2}} = \sqrt{1 - \frac{b^2}{a^2}} = \sqrt{1 - \frac{4}{9}} = \frac{\sqrt{5}}{3}$$

is independent of 'n', so eccentricity of E_{18} and E_{19} are equal.

Option (b),

Distance between focus and centre of $E_9 = e \cdot a_9$

$$= \frac{a}{(\sqrt{2})^8} (e) = \frac{3}{2^4} \times \frac{\sqrt{5}}{3} = \frac{\sqrt{5}}{16} \text{ unit}$$

Option (c),

$\therefore \sum_{n=1}^N (\text{area of } R_n) < (\text{area of } R_1) + (\text{area of } R_2) + \dots \infty$

$$< 2ab + 2 \frac{ab}{2} + 2 \frac{ab}{2^2} + \dots$$

$$< 2ab \left(1 + \frac{1}{2} + \frac{1}{2^2} + \dots\right)$$

$$< 12 \left(\frac{1}{1 - 1/2}\right)$$

$\Rightarrow \sum_{n=1}^N (\text{area of } R_n) < 24$, for each positive integer N .

Option (d),

$$\begin{aligned} \text{Length of latusrectum } E_9 &= \frac{2b_9^2}{a_9} = \frac{2b^2}{a(\sqrt{2})^8} \\ &= \frac{2 \times 4}{3 \times 16} = \frac{1}{6} \text{ units} \end{aligned}$$

Hence, options (c) and (d) are correct.

10. We have,

Equation of circle $x^2 + y^2 = \frac{1}{2}$

and Equation of parabola $y^2 = 4x$

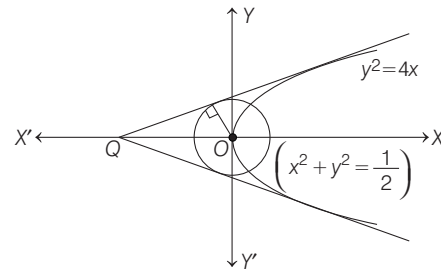

Let the equation of common tangent of parabola and circle is

$$y = mx + \frac{1}{m}$$

Since, radius of circle = $\frac{1}{\sqrt{2}}$

$$\therefore \frac{1}{\sqrt{2}} = \left| \frac{0 + 0 + \frac{1}{m}}{\sqrt{1 + m^2}} \right|$$

$$\Rightarrow m^4 + m^2 - 2 = 0 \Rightarrow m = \pm 1$$

\therefore Equation of common tangents are

$$y = x + 1 \text{ and } y = -x - 1$$

Intesection point of common tangent at $Q(-1, 0)$

\therefore Equation of ellipse $\frac{x^2}{1} + \frac{y^2}{1/2} = 1$

where, $a^2 = 1$, $b^2 = 1/2$

Now, eccentricity $(e) = \sqrt{1 - \frac{b^2}{a^2}} = \sqrt{1 - \frac{1}{2}} = \frac{1}{\sqrt{2}}$

and length of latusrectum = $\frac{2b^2}{a} = \frac{2\left(\frac{1}{2}\right)}{1} = 1$

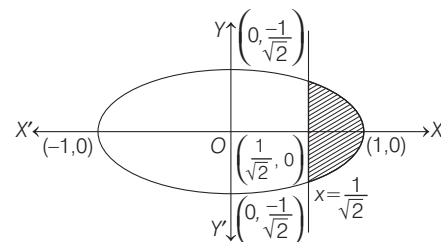

$$\begin{aligned} \therefore \text{Area of shaded region} &= 2 \int_{1/\sqrt{2}}^1 \frac{1}{\sqrt{2}} \sqrt{1-x^2} dx \\ &= \sqrt{2} \left[\frac{x}{2} \sqrt{1-x^2} + \frac{1}{2} \sin^{-1} x \right]_{1/\sqrt{2}}^1 \\ &= \sqrt{2} \left[\left(0 + \frac{\pi}{4}\right) - \left(\frac{1}{4} + \frac{\pi}{8}\right) \right] = \sqrt{2} \left(\frac{\pi}{8} - \frac{1}{4} \right) = \frac{\pi-2}{4\sqrt{2}} \end{aligned}$$

11. Since, angle FBF' is right angled.
 \therefore (Slope of FB) \cdot (Slope of $F'B$) = -1

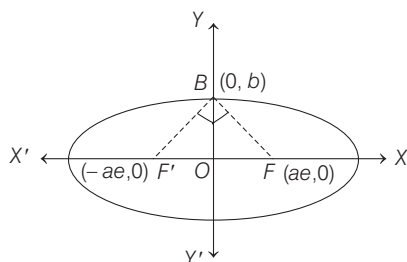

$$\begin{aligned} \Rightarrow \left(\frac{0-b}{ae-0} \right) \cdot \left(\frac{0-b}{-ae-0} \right) &= -1 \\ \Rightarrow \frac{b^2}{-a^2e^2} &= -1 \Rightarrow b^2 = a^2e^2 \\ \Rightarrow a^2(1-e^2) &= a^2e^2 \Rightarrow e^2 = 1/2 \Rightarrow e = 1/\sqrt{2} \end{aligned}$$

12. There are two common tangents to the circle $x^2 + y^2 = 1$ and the hyperbola $x^2 - y^2 = 1$. These are $x = 1$ and $x = -1$. But $x = 1$ is nearer to the point $P(1/2, 1)$. Therefore, directrix of the required ellipse is $x = 1$. Now, if $Q(x, y)$ is any point on the ellipse, then its distance from the focus is

$$QP = \sqrt{(x-1/2)^2 + (y-1)^2}$$

and its distance from the directrix is $|x-1|$.

By definition of ellipse,

$$QP = e|x-1| \Rightarrow \sqrt{\left(x-\frac{1}{2}\right)^2 + (y-1)^2} = \frac{1}{2}|x-1|$$

$$\Rightarrow \left(x-\frac{1}{2}\right)^2 + (y-1)^2 = \frac{1}{4}(x-1)^2$$

$$\Rightarrow x^2 - x + \frac{1}{4} + y^2 - 2y + 1 = \frac{1}{4}(x^2 - 2x + 1)$$

$$\Rightarrow 4x^2 - 4x + 1 + 4y^2 - 8y + 4 = x^2 - 2x + 1$$

$$\Rightarrow 3x^2 - 2x + 4y^2 - 8y + 4 = 0$$

$$\Rightarrow 3 \left[\left(x-\frac{1}{3}\right)^2 - \frac{1}{9} \right] + 4(y-1)^2 = 0$$

$$\Rightarrow 3 \left(x-\frac{1}{3}\right)^2 + 4(y-1)^2 = \frac{1}{3}$$

$$\Rightarrow \frac{\left(x-\frac{1}{3}\right)^2}{1/9} + \frac{(y-1)^2}{1/12} = 1$$

13. Given, $\frac{x^2}{a^2} + \frac{y^2}{b^2} = 1$

Foci F_1 and F_2 are $(-ae, 0)$ and $(ae, 0)$, respectively. Let $P(x, y)$ be any variable point on the ellipse.

The area A of the triangle PF_1F_2 is given by

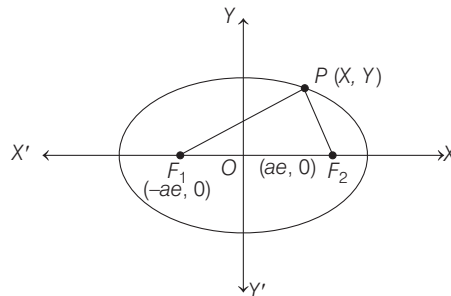

$$\begin{aligned} A &= \frac{1}{2} \begin{vmatrix} x & y & 1 \\ -ae & 0 & 1 \\ ae & 0 & 1 \end{vmatrix} \\ &= \frac{1}{2} (-y) (-ae \times 1 - ae \times 1) \end{aligned}$$

$$= -\frac{1}{2} y (-2ae) = aey = ae \cdot b \sqrt{1 - \frac{x^2}{a^2}}$$

So, A is maximum when $x = 0$.

$$\begin{aligned} \therefore \text{Maximum of } A &= abe = ab \sqrt{1 - \frac{b^2}{a^2}} = ab \sqrt{\frac{a^2 - b^2}{a^2}} \\ &= b \sqrt{a^2 - b^2} \end{aligned}$$

14. Given, $\frac{PR}{RQ} = \frac{r}{s}$

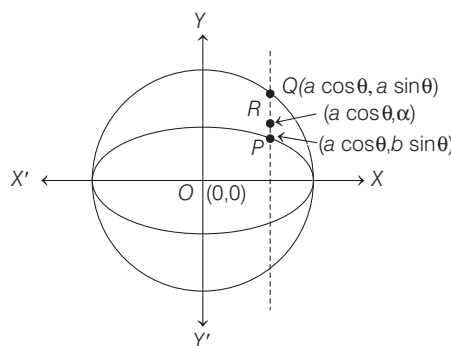

$$\Rightarrow \frac{\alpha - b \sin \theta}{a \sin \theta - \alpha} = \frac{r}{s}$$

$$\Rightarrow \alpha s - b \sin \theta \cdot s = ra \sin \theta - \alpha r$$

$$\Rightarrow \alpha s + \alpha r = ra \sin \theta + b \sin \theta \cdot s$$

$$\Rightarrow \alpha (s + r) = \sin \theta (ra + bs)$$

$$\Rightarrow \alpha = \frac{\sin \theta (ra + bs)}{r + s}$$

Let the coordinates of R be (h, k) .

$$\therefore h = a \cos \theta \Rightarrow \cos \theta = \frac{h}{a} \quad \dots(i)$$

466 Ellipse

$$\begin{aligned} \text{and} \quad k &= \alpha = \frac{(ar + bs) \sin \theta}{r + s} \\ \Rightarrow \quad \sin \theta &= \frac{k(r + s)}{ar + bs} \quad \dots(\text{ii}) \end{aligned}$$

On squaring and adding Eqs. (i) and (ii), we get

$$\begin{aligned} \sin^2 \theta + \cos^2 \theta &= \frac{h^2}{a^2} + \frac{k^2(r + s)^2}{(ar + bs)^2} \\ \Rightarrow \quad 1 &= \frac{h^2}{a^2} + \frac{k^2(r + s)^2}{(ar + bs)^2} \end{aligned}$$

$$\text{Hence, locus of } R \text{ is } \frac{x^2}{a^2} + \frac{y^2(r + s)^2}{(ar + bs)^2} = 1.$$

15. Here, $\frac{x^2}{9} + \frac{y^2}{8} = 1$... (i)

has foci $(\pm ae, 0)$

where,

$$a^2 e^2 = a^2 - b^2$$

$$\Rightarrow a^2 e^2 = 9 - 8$$

$$\Rightarrow ae = \pm 1$$

$$\text{i.e. } F_1, F_2 = (\pm 1, 0)$$

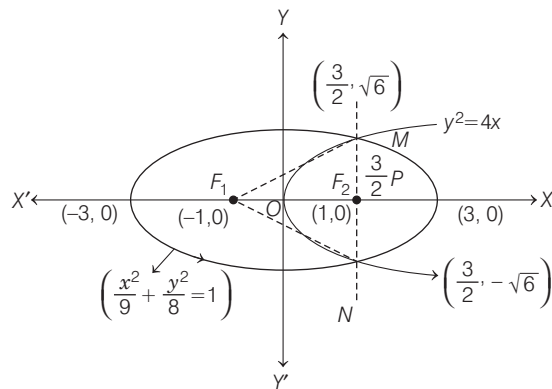

Equation of parabola having vertex $O(0, 0)$ and $F_2(1, 0)$ (as, $x_2 > 0$)

$$y^2 = 4x \quad \dots(\text{ii})$$

On solving $\frac{x^2}{9} + \frac{y^2}{8} = 1$ and $y^2 = 4x$, we get

$$x = 3/2 \text{ and } y = \pm \sqrt{6}$$

Equation of altitude through M on NF_1 is

$$\frac{y - \sqrt{6}}{x - 3/2} = \frac{5}{2\sqrt{6}}$$

$$\Rightarrow (y - \sqrt{6}) = \frac{5}{2\sqrt{6}}(x - 3/2) \quad \dots(\text{iii})$$

and equation of altitude through F_1 is $y = 0$... (iv)

On solving Eqs. (iii) and (iv), we get $(-\frac{9}{10}, 0)$ as orthocentre.

16. Equation of tangent at $M(3/2, \sqrt{6})$ to $\frac{x^2}{9} + \frac{y^2}{8} = 1$ is

$$\frac{3}{2} \cdot \frac{x}{9} + \sqrt{6} \cdot \frac{y}{8} = 1 \quad \dots(\text{i})$$

which intersect X -axis at $(6, 0)$.

Also, equation of tangent at $N(3/2, -\sqrt{6})$ is

$$\frac{3}{2} \cdot \frac{x}{9} - \sqrt{6} \cdot \frac{y}{8} = 1 \quad \dots(\text{ii})$$

Eqs. (i) and (ii) intersect on X -axis at $R(6, 0)$ (iii)

Also, normal at $M(3/2, \sqrt{6})$ is $y - \sqrt{6} = \frac{-\sqrt{6}}{2} \left(x - \frac{3}{2}\right)$

On solving with $y = 0$, we get $Q(7/2, 0)$... (iv)

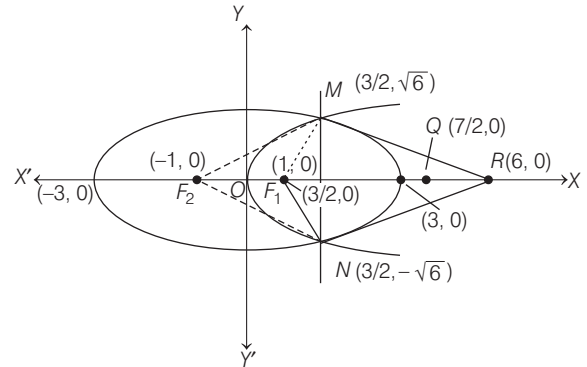

$$\therefore \text{Area of } \Delta MQR = \frac{1}{2} \left(6 - \frac{7}{2}\right) \sqrt{6} = \frac{5\sqrt{6}}{4} \text{ sq units}$$

$$\begin{aligned} \text{and area of quadrilateral } MF_1NF_2 &= 2 \times \frac{1}{2} \{1 - (-1)\} \sqrt{6} \\ &= 2\sqrt{6} \text{ sq units} \end{aligned}$$

$$\therefore \frac{\text{Area of } \Delta MQR}{\text{Area of quadrilateral } MF_1NF_2} = \frac{5}{8}$$

Topic 2 Equation of Tangent and Normal

1. Equation of given parabola is

$$y^2 = 4\lambda x \quad \dots (\text{i})$$

So the end point of the latus rectum of the parabola (i),

$P(\lambda, 2\lambda)$ and the given ellipse $\frac{x^2}{a^2} + \frac{y^2}{b^2} = 1$, passes

through point $P(\lambda, 2\lambda)$.

On differentiating the equation of parabola, w.r.t. 'x', we get

$$\frac{dy}{dx} = \frac{2\lambda}{y}$$

\therefore Slope of tangent to the parabola at point P is $m_1 = 1$

Similarly, on differentiating the equation of given

ellipse, $\frac{x^2}{a^2} + \frac{y^2}{b^2} = 1$, w.r.t x , we get

$$\frac{2x}{a^2} + \frac{2y}{b^2} \frac{dy}{dx} = 0 \Rightarrow \frac{dy}{dx} = -\frac{b^2 x}{a^2 y}$$

\therefore Slope of tangent to the ellipse at point P is $m_2 = -\frac{b^2}{2a^2}$

\therefore It is given that the tangents are perpendicular to each other. So,

$$m_1 m_2 = -1 \Rightarrow (1) \left(-\frac{b^2}{2a^2}\right) = -1$$

$$\Rightarrow \frac{b^2}{a^2} = 2 \Rightarrow b = \sqrt{2}a$$

∴ Eccentricity of ellipse $\frac{x^2}{a^2} + \frac{y^2}{b^2} = 1$ will be

$$e = \sqrt{1 - \frac{a^2}{b^2}} = \sqrt{1 - \frac{1}{2}} = \frac{1}{\sqrt{2}} \quad \{\because b > a\}$$

2. As we know that locus of the foot of perpendicular drawn upon any tangent to the ellipse $\frac{x^2}{4} + \frac{y^2}{2} = 1$ from any of its foci is the auxilliary circle and its equation is $x^2 + y^2 = 4$... (i)

So, from the option the auxilliary circle (i) passes through the point $(-1, \sqrt{3})$.

3. **Key Idea** Equation of tangent and normal to the ellipse $\frac{x^2}{a^2} + \frac{y^2}{b^2} = 1$ at point $P(x_1, y_1)$ is $T = 0 \Rightarrow \frac{xx_1}{a^2} + \frac{yy_1}{b^2} = 1$ and $\frac{a^2x}{x_1} - \frac{b^2y}{y_1} = a^2 - b^2$ respectively.

Equation of given ellipse is $3x^2 + 4y^2 = 12$
 $\Rightarrow \frac{x^2}{4} + \frac{y^2}{3} = 1$... (i)

Now, let point $P(2 \cos \theta, \sqrt{3} \sin \theta)$, so equation of tangent to ellipse (i) at point P is

$$\frac{x \cos \theta}{2} + \frac{y \sin \theta}{\sqrt{3}} = 1 \quad \dots \text{(ii)}$$

Since, tangent (ii) passes through point $Q(4, 4)$
 $\therefore 2 \cos \theta + \frac{4}{\sqrt{3}} \sin \theta = 1$... (iii)

and equation of normal to ellipse (i) at point P is
 $\frac{4x}{2 \cos \theta} - \frac{3y}{\sqrt{3} \sin \theta} = 4 - 3$
 $\Rightarrow 2x \sin \theta - \sqrt{3} \cos \theta y = \sin \theta \cos \theta$... (iv)

Since, normal (iv) is parallel to line, $2x + y = 4$
 \therefore Slope of normal (iv) = slope of line, $2x + y = 4$
 $\Rightarrow \frac{2}{\sqrt{3}} \tan \theta = -2 \Rightarrow \tan \theta = -\sqrt{3} \Rightarrow \theta = 120^\circ$

$$\Rightarrow (\sin \theta, \cos \theta) = \left(\frac{\sqrt{3}}{2}, -\frac{1}{2} \right)$$

Hence, point $P\left(-1, \frac{3}{2}\right)$
 Now, $PQ = \sqrt{(4+1)^2 + \left(4 - \frac{3}{2}\right)^2}$
 $= \sqrt{25 + \frac{25}{4}} = \frac{5\sqrt{5}}{2}$ [given coordinates of $Q \equiv (4, 4)$]

4. Equation of given ellipse is $3x^2 + 5y^2 = 32$... (i)

Now, the slope of tangent and normal at point $P(2, 2)$ to the ellipse (i) are respectively

$$m_T = \frac{dy}{dx}\bigg|_{(2,2)} \quad \text{and} \quad m_N = -\frac{dx}{dy}\bigg|_{(2,2)}$$

On differentiating ellipse (i), w.r.t. x , we get

$$6x + 10y \frac{dy}{dx} = 0 \Rightarrow \frac{dy}{dx} = -\frac{3x}{5y}$$

So, $m_T = -\frac{3x}{5y}\bigg|_{(2,2)} = -\frac{3}{5}$ and $m_N = \frac{5y}{3x}\bigg|_{(2,2)} = \frac{5}{3}$

Now, equation of tangent and normal to the given ellipse (i) at point $P(2, 2)$ are

$$(y - 2) = -\frac{3}{5}(x - 2)$$

and $(y - 2) = \frac{5}{3}(x - 2)$ respectively.

It is given that point of intersection of tangent and normal are Q and R at X -axis respectively.

So, $Q\left(\frac{16}{3}, 0\right)$ and $R\left(\frac{4}{5}, 0\right)$

∴ Area of $\Delta PQR = \frac{1}{2} (QR) \times \text{height}$
 $= \frac{1}{2} \times \frac{68}{15} \times 2 = \frac{68}{15}$ sq units

[∵ $QR = \sqrt{\left(\frac{16}{3} - \frac{4}{5}\right)^2} = \sqrt{\left(\frac{68}{15}\right)^2} = \frac{68}{15}$ and height = 2]

5. **Key Idea** Write equation of the tangent to the ellipse at any point and use formula for latusrectum of ellipse.

Equation of given ellipse is $\frac{x^2}{a^2} + \frac{y^2}{b^2} = 1$... (i)

Now, equation of tangent at the point $\left(3, -\frac{9}{2}\right)$ on the ellipse (i) is

$$\Rightarrow \frac{3x}{a^2} - \frac{9y}{2b^2} = 1 \quad \dots \text{(ii)}$$

[∵ the equation of the tangent to the ellipse $\frac{x^2}{a^2} + \frac{y^2}{b^2} = 1$ at the point (x_1, y_1) is $\frac{xx_1}{a^2} + \frac{yy_1}{b^2} = 1$]

∴ Tangent (ii) represent the line $x - 2y = 12$, so

$$\frac{1}{3} = \frac{2}{9} = \frac{12}{a^2} = \frac{2}{2b^2}$$

$$\Rightarrow a^2 = 36 \text{ and } b^2 = 27$$

Now, Length of latusrectum = $\frac{2b^2}{a} = \frac{2 \times 27}{6} = 9$ units

6. Since the point (α, β) is on the parabola $y^2 = x$, so $\alpha = \beta^2$... (i)

Now, equation of tangent at point (α, β) to the parabola $y^2 = x$, is $T = 0$

$$\Rightarrow y\beta = \frac{1}{2}(x + \alpha)$$

[∵ equation of the tangent to the parabola $y^2 = 4ax$ at a point (x_1, y_1) is given by $yy_1 = 2a(x + x_1)$]

468 Ellipse

$$\begin{aligned} \Rightarrow 2y\beta &= x + \beta^2 && \text{[from Eq. (i)]} \\ \Rightarrow y &= \frac{x}{2\beta} + \frac{\beta}{2} && \dots(ii) \end{aligned}$$

Since, line (ii) is also a tangent of the ellipse $x^2 + 2y^2 = 1$

$$\therefore \left(\frac{\beta}{2}\right)^2 = (1)^2 \left(\frac{1}{2\beta}\right)^2 + \frac{1}{2}$$

[∵ condition of tangency of line $y = mx + c$ to ellipse $\frac{x^2}{a^2} + \frac{y^2}{b^2} = 1$ is $c^2 = a^2m^2 + b^2$,

$$\text{here } m = \frac{1}{2\beta}, a = 1, b = \frac{1}{\sqrt{2}} \text{ and } c = \frac{\beta}{2}$$

$$\Rightarrow \frac{\beta^2}{4} = \frac{1}{4\beta^2} + \frac{1}{\sqrt{2}}$$

$$\Rightarrow \beta^4 = 1 + 2\beta^2$$

$$\Rightarrow \beta^4 - 2\beta^2 - 1 = 0$$

$$\Rightarrow \beta^2 = \frac{2 \pm \sqrt{4+4}}{2} = \frac{2 \pm 2\sqrt{2}}{2} = 1 \pm \sqrt{2}$$

$$\Rightarrow \beta^2 = 1 + \sqrt{2} \quad [\because \beta^2 > 0]$$

$$\therefore \alpha = \beta^2 = 1 + \sqrt{2}$$

7. Equation of given ellipse is

$$4x^2 + y^2 = 8 \quad \dots(i)$$

$$\Rightarrow \frac{x^2}{2} + \frac{y^2}{8} = 1 \Rightarrow \frac{x^2}{(\sqrt{2})^2} + \frac{y^2}{(2\sqrt{2})^2} = 1$$

Now, equation of tangent at point (1, 2) is $2x + y = 4$... (ii)

[∵ equation of tangent to the ellipse $\frac{x^2}{a^2} + \frac{y^2}{b^2} = 1$ at (x_1, y_1) is

$$\frac{xx_1}{a^2} + \frac{yy_1}{b^2} = 1]$$

and equation of another tangent at point (a, b) is $4ax + by = 8$... (iii)

Since, lines (ii) and (iii) are perpendicular to each other.

$$\therefore \left(-\frac{2}{1}\right) \times \left(-\frac{4a}{b}\right) = -1$$

[if lines $a_1x + b_1y + c_1 = 0$ and $a_2x + b_2y + c_2 = 0$

are perpendicular, then $\left(-\frac{a_1}{b_1}\right) \left(-\frac{a_2}{b_2}\right) = -1]$

$$\Rightarrow b = -8a \quad \dots(iv)$$

Also, the point (a, b) lies on the ellipse (i), so

$$4a^2 + b^2 = 8$$

$$\Rightarrow 4a^2 + 64a^2 = 8 \quad \text{[from Eq. (iv)]}$$

$$\Rightarrow 68a^2 = 8 \Rightarrow a^2 = \frac{8}{68}$$

$$\Rightarrow a^2 = \frac{2}{17}$$

8. Given equation of ellipse is $x^2 + 2y^2 = 2$, which can be written as $\frac{x^2}{2} + \frac{y^2}{1} = 1$

Let P be a point on the ellipse, other than its four vertices. Then, the parametric coordinates of P be $(\sqrt{2} \cos \theta, \sin \theta)$

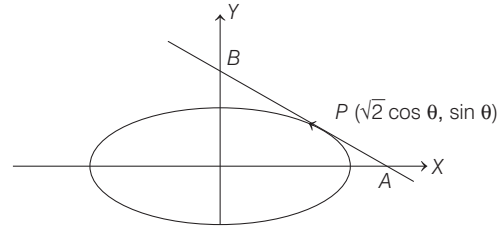

Now, the equation of tangent at P is

$$\frac{x\sqrt{2} \cos \theta}{2} + \frac{y \sin \theta}{1} = 1$$

[∵ equation of tangent at (x_1, y_1) is given by $T = 0$
 $\Rightarrow \frac{xx_1}{a^2} + \frac{yy_1}{b^2} = 1$]

$$\Rightarrow \frac{x}{\sqrt{2} \sec \theta} + \frac{y}{\csc \theta} = 1$$

∴ $A(\sqrt{2} \sec \theta, 0)$ and $B(0, \csc \theta)$

Let mid-point of AB be $R(h, k)$, then

$$h = \frac{\sqrt{2} \sec \theta}{2} \text{ and } k = \frac{\csc \theta}{2}$$

$$2h = \sqrt{2} \sec \theta \text{ and } 2k = \csc \theta$$

$$\Rightarrow \cos \theta = \frac{1}{\sqrt{2}h} \text{ and } \sin \theta = \frac{1}{2k}$$

We know that, $\cos^2 \theta + \sin^2 \theta = 1$

$$\therefore \frac{1}{2h^2} + \frac{1}{4k^2} = 1$$

So, locus of (h, k) is $\frac{1}{2x^2} + \frac{1}{4y^2} = 1$

9. We know that, $y = mx + \frac{a}{m}$ is the equation of tangent to the parabola $y^2 = 4ax$.

∴ $y = mx + \frac{1}{m}$ is a tangent to the parabola

$$y^2 = 4x. \quad [\because a = 1]$$

Let, this tangent is also a tangent to the hyperbola $xy = 2$

Now, on substituting $y = mx + \frac{1}{m}$ in $xy = 2$, we get

$$\begin{aligned} x \left(mx + \frac{1}{m} \right) &= 2. \\ \Rightarrow m^2x^2 + x - 2m &= 0 \end{aligned}$$

Note that tangent touch the curve exactly at one point, therefore both roots of above equations are equal.

$$\Rightarrow D = 0 \Rightarrow 1 - 4(m^2)(-2m) \Rightarrow m^3 = \left(-\frac{1}{2}\right)^3$$

$$\Rightarrow m = -\frac{1}{2}$$

∴ Required equation of tangent is

$$y = -\frac{x}{2} - 2$$

$$\Rightarrow 2y = -x - 4$$

$$\Rightarrow x + 2y + 4 = 0$$

10. We have, $e = \frac{1}{2}$ and $\frac{a}{e} = 4$

$\therefore a = 2$

Now, $b^2 = a^2(1 - e^2) = (2)^2 \left[1 - \left(\frac{1}{2}\right)^2 \right] = 4 \left(1 - \frac{1}{4} \right) = 3$

$\Rightarrow b = \sqrt{3}$

\therefore Equation of the ellipse is $\frac{x^2}{(2)^2} + \frac{y^2}{(\sqrt{3})^2} = 1$

$\Rightarrow \frac{x^2}{4} + \frac{y^2}{3} = 1$

Now, the equation of normal at $\left(1, \frac{3}{2}\right)$ is

$$\frac{a^2x}{x_1} - \frac{b^2y}{y_1} = a^2 - b^2$$

$\Rightarrow \frac{4x}{1} - \frac{3y}{(3/2)} = 4 - 3$

$\Rightarrow 4x - 2y = 1$

11. Given equation of ellipse is

$$\frac{x^2}{9} + \frac{y^2}{5} = 1$$

$\therefore a^2 = 9, b^2 = 5 \Rightarrow a = 3, b = \sqrt{5}$

Now, $e = \sqrt{1 + \frac{b^2}{a^2}} = \sqrt{1 + \frac{5}{9}} = \frac{2}{3}$

Foci = $(\pm ae, 0) = (\pm 2, 0)$ and $\frac{b^2}{a} = \frac{5}{3}$

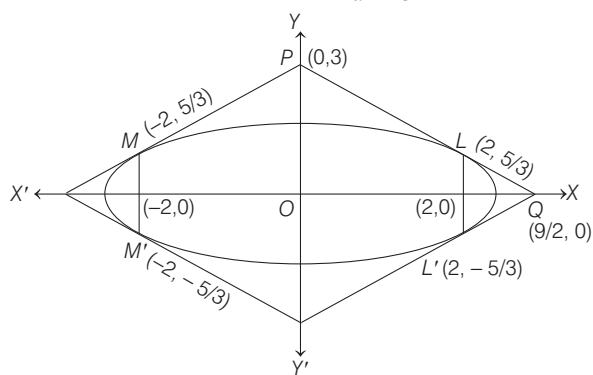

\therefore Extremities of one of latusrectum are

$$\left(2, \frac{5}{3}\right) \text{ and } \left(2, -\frac{5}{3}\right)$$

\therefore Equation of tangent at $\left(2, \frac{5}{3}\right)$ is

$$\frac{x(2)}{9} + \frac{y(5/3)}{5} = 1 \text{ or } 2x + 3y = 9$$

Since, Eq. (ii) intersects X and Y-axes at $\left(\frac{9}{2}, 0\right)$ and $(0, 3)$, respectively.

\therefore Area of quadrilateral = $4 \times$ Area of ΔPOQ
 $= 4 \times \left(\frac{1}{2} \times \frac{9}{2} \times 3\right) = 27$ sq units

12. Equation of ellipse is $x^2 + 3y^2 = 6$ or $\frac{x^2}{6} + \frac{y^2}{2} = 1$.

Equation of the tangent is $\frac{x \cos \theta}{a} + \frac{y \sin \theta}{b} = 1$

Let (h, k) be any point on the locus.

$\therefore \frac{h}{a} \cos \theta + \frac{k}{b} \sin \theta = 1 \quad \dots(i)$

Slope of the tangent line is $-\frac{b}{a} \cot \theta$.

Slope of perpendicular drawn from centre $(0,0)$ to (h, k) is k/h .

Since, both the lines are perpendicular.

$\therefore \left(\frac{k}{h}\right) \times \left(-\frac{b}{a} \cot \theta\right) = -1$

$\Rightarrow \frac{\cos \theta}{ha} = \frac{\sin \theta}{kb} = \alpha \quad [\text{say}]$

$\Rightarrow \cos \theta = \alpha ha$

$\sin \theta = \alpha kb$

From Eq. (i), $\frac{h}{a} (\alpha ha) + \frac{k}{b} (\alpha kb) = 1$

$\Rightarrow h^2 \alpha + k^2 \alpha = 1$

$\Rightarrow \alpha = \frac{1}{h^2 + k^2}$

Also, $\sin^2 \theta + \cos^2 \theta = 1$

$\Rightarrow (\alpha kb)^2 + (\alpha ha)^2 = 1$

$\Rightarrow \alpha^2 k^2 b^2 + \alpha^2 h^2 a^2 = 1$

$\Rightarrow \frac{k^2 b^2}{(h^2 + k^2)^2} + \frac{h^2 a^2}{(h^2 + k^2)^2} = 1$

$\Rightarrow \frac{2k^2}{(h^2 + k^2)^2} + \frac{6h^2}{(h^2 + k^2)^2} = 1 \quad [\because a^2 = 6, b^2 = 2]$

$\Rightarrow 6x^2 + 2y^2 = (x^2 + y^2)^2$

[replacing k by y and h by x]

13. Given, $\frac{x^2}{16} + \frac{y^2}{4} = 1$

Here, $a = 4, b = 2$

Equation of normal

$4x \sec \theta - 2y \csc \theta = 12$

$M \left(\frac{7 \cos \theta}{2}, \sin \theta \right) = (h, k) \quad [\text{say}]$

$\therefore h = \frac{7 \cos \theta}{2}$

$\Rightarrow \frac{2h}{7} = \cos \theta \quad \dots(i)$

and $k = \sin \theta \quad \dots(ii)$

On squaring and adding Eqs. (i) and (ii), we get

$\frac{4h^2}{49} + k^2 = 1 \quad [\because \cos^2 \theta + \sin^2 \theta = 1]$

Hence, locus is $\frac{4x^2}{49} + y^2 = 1 \quad \dots(iii)$

470 Ellipse

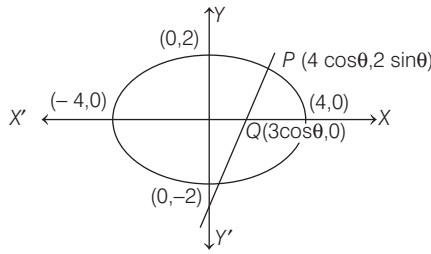

For given ellipse, $e^2 = 1 - \frac{4}{16} = \frac{3}{4}$

$$\therefore e = \frac{\sqrt{3}}{2}$$

$$\therefore x = \pm 4 \times \frac{\sqrt{3}}{2} = \pm 2\sqrt{3} \quad [\because x = \pm ae] \dots(\text{iv})$$

On solving Eqs. (iii) and (iv), we get

$$\frac{4}{49} \times 12 + y^2 = 1 \Rightarrow y^2 = 1 - \frac{48}{49} = \frac{1}{49}$$

$$y = \pm \frac{1}{7}$$

\therefore Required points $\left(\pm 2\sqrt{3}, \pm \frac{1}{7} \right)$.

14. Equation of auxiliary circle is

$$x^2 + y^2 = 9 \quad \dots (\text{i})$$

Equation of AM is $\frac{x}{3} + \frac{y}{1} = 1 \quad \dots (\text{ii})$

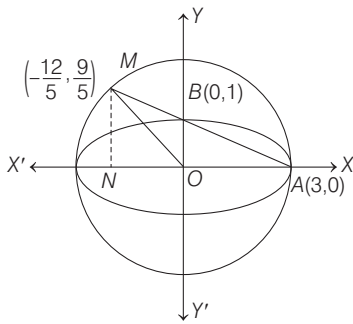

On solving Eqs. (i) and (ii), we get $M\left(-\frac{12}{5}, \frac{9}{5}\right)$.

Now, area of $\Delta AOM = \frac{1}{2} \cdot OA \times MN = \frac{27}{10}$ sq units

15. Let the point $P(\sqrt{2} \cos \theta, \sin \theta)$ on $\frac{x^2}{2} + \frac{y^2}{1} = 1$.

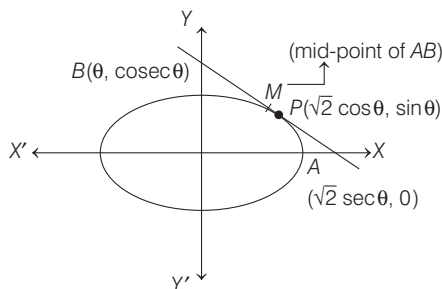

Equation of tangent is, $\frac{x\sqrt{2}}{2} \cos \theta + y \sin \theta = 1$

whose intercept on coordinate axes are $A(\sqrt{2} \sec \theta, 0)$ and $B(0, \csc \theta)$

\therefore Mid-point of its intercept between axes

$$\left(\frac{\sqrt{2}}{2} \sec \theta, \frac{1}{2} \csc \theta \right) = (h, k)$$

$$\Rightarrow \cos \theta = \frac{1}{\sqrt{2}h} \text{ and } \sin \theta = \frac{1}{2k}$$

Thus, focus of mid-point M is

$$(\cos^2 \theta + \sin^2 \theta) = \frac{1}{2h^2} + \frac{1}{4k^2}$$

$$\Rightarrow \frac{1}{2x^2} + \frac{1}{4y^2} = 1, \text{ is required locus.}$$

16. Given, tangent is drawn at $(3\sqrt{3} \cos \theta, \sin \theta)$ to $\frac{x^2}{27} + \frac{y^2}{1} = 1$.

\therefore Equation of tangent is $\frac{x \cos \theta}{3\sqrt{3}} + \frac{y \sin \theta}{1} = 1$.

Thus, sum of intercepts = $\left(\frac{3\sqrt{3}}{\cos \theta} + \frac{1}{\sin \theta} \right) = f(\theta)$ [say]

$$\Rightarrow f'(\theta) = \frac{3\sqrt{3} \sin^3 \theta - \cos^3 \theta}{\sin^2 \theta \cos^2 \theta}, \text{ put } f'(\theta) = 0$$

$$\Rightarrow \sin^3 \theta = \frac{1}{3^{3/2}} \cos^3 \theta$$

$$\Rightarrow \tan \theta = \frac{1}{\sqrt{3}}, \text{ i.e. } \theta = \frac{\pi}{6} \text{ and at } \theta = \frac{\pi}{6}, f''(\theta) > 0$$

Hence, tangent is minimum at $\theta = \frac{\pi}{6}$.

17. Given, $y = mx - b\sqrt{1+m^2}$ touches both the circles, so distance from centre = radius of both the circles.

$$\frac{|ma - 0 - b\sqrt{1+m^2}|}{\sqrt{m^2+1}} = b \text{ and } \frac{|-b\sqrt{1+m^2}|}{\sqrt{m^2+1}} = b$$

$$\Rightarrow |ma - b\sqrt{1+m^2}| = |-b\sqrt{1+m^2}|$$

$$\Rightarrow m^2 a^2 - 2abm\sqrt{1+m^2} + b^2(1+m^2) = b^2(1+m^2)$$

$$\Rightarrow ma - 2b\sqrt{1+m^2} = 0$$

$$\Rightarrow m^2 a^2 = 4b^2(1+m^2)$$

$$\therefore m = \frac{2b}{\sqrt{a^2 - 4b^2}}$$

18. For ellipse, condition of tangency is $c^2 = a^2 m^2 + b^2$

Given line is $y = 4x + c$ and curve $\frac{x^2}{4} + y^2 = 1$

$$\Rightarrow c^2 = 4 \times 4^2 + 1 = 65$$

$$\Rightarrow c = \pm \sqrt{65}$$

So, there are two different values of c .

19. Here, $E_1: \frac{x^2}{a^2} + \frac{y^2}{b^2} = 1, (a > b)$
 $E_2: \frac{x^2}{c^2} + \frac{y^2}{d^2} = 1, (c < d)$ and $S: x^2 + (y-1)^2 = 2$
 as tangent to E_1, E_2 and S is $x + y = 3$.

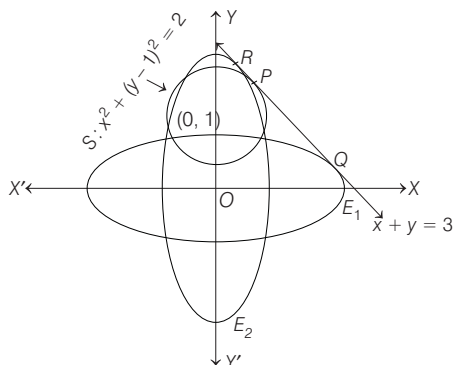

Let the point of contact of tangent be (x_1, y_1) to S .

$$\begin{aligned} \therefore & x \cdot x_1 + y \cdot y_1 - (y + y_1) + 1 = 2 \\ \text{or } & x x_1 + y y_1 - y = (1 + y_1), \text{ same as } x + y = 3. \\ \Rightarrow & \frac{x_1}{1} = \frac{y_1 - 1}{1} = \frac{1 + y_1}{3} \end{aligned}$$

i.e. $x_1 = 1$ and $y_1 = 2 \Rightarrow P = (1, 2)$

Since, $PR = PQ = \frac{2\sqrt{2}}{3}$. Thus, by parametric form,

$$\begin{aligned} \frac{x-1}{-1/\sqrt{2}} &= \frac{y-2}{1/\sqrt{2}} = \pm \frac{2\sqrt{2}}{3} \\ \Rightarrow & \left(x = \frac{5}{3}, y = \frac{4}{3}\right) \text{ and } \left(x = \frac{1}{3}, y = \frac{8}{3}\right) \\ \therefore & Q = \left(\frac{5}{3}, \frac{4}{3}\right) \text{ and } R = \left(\frac{1}{3}, \frac{8}{3}\right) \end{aligned}$$

Now, equation of tangent at Q on ellipse E_1 is

$$\frac{x \cdot 5}{a^2 \cdot 3} + \frac{y \cdot 4}{b^2 \cdot 3} = 1$$

On comparing with $x + y = 3$, we get

$$a^2 = 5 \text{ and } b^2 = 4 \Rightarrow e_1^2 = 1 - \frac{b^2}{a^2} = 1 - \frac{4}{5} = \frac{1}{5} \quad \dots(i)$$

Also, equation of tangent at R on ellipse E_2 is

$$\frac{x \cdot 1}{a^2 \cdot 3} + \frac{y \cdot 8}{b^2 \cdot 3} = 1$$

On comparing with $x + y = 3$, we get

$$a^2 = 1, b^2 = 8 \Rightarrow e_2^2 = 1 - \frac{a^2}{b^2} = 1 - \frac{1}{8} = \frac{7}{8} \quad \dots(ii)$$

Now, $e_1^2 \cdot e_2^2 = \frac{7}{40} \Rightarrow e_1 e_2 = \frac{\sqrt{7}}{2\sqrt{10}}$

and $e_1^2 + e_2^2 = \frac{1}{5} + \frac{7}{8} = \frac{43}{40}$

Also, $|e_1^2 - e_2^2| = \left| \frac{1}{5} - \frac{7}{8} \right| = \frac{27}{40}$

20. Let the common tangent to $x^2 + y^2 = 16$ and $\frac{x^2}{25} + \frac{y^2}{4} = 1$ be

$$y = mx + 4\sqrt{1+m^2} \quad \dots(i)$$

and $y = mx + \sqrt{25m^2 + 4} \quad \dots(ii)$

Since, Eqs. (i) and (ii) are same tangent.

$$\therefore 4\sqrt{1+m^2} = \sqrt{25m^2 + 4} \Rightarrow 16(1+m^2) = 25m^2 + 4$$

$$\Rightarrow 9m^2 = 12 \Rightarrow m = \pm 2/\sqrt{3}$$

Since, tangent is in Ist quadrant.

$$\therefore m < 0 \Rightarrow m = -2/\sqrt{3}$$

So, the equation of the common tangent is

$$y = -\frac{2x}{\sqrt{3}} + 4\sqrt{\frac{7}{3}}$$

which meets coordinate axes at $A(2\sqrt{7}, 0)$ and

$$\left(0, 4\sqrt{\frac{7}{3}}\right).$$

$$\begin{aligned} \therefore AB &= \sqrt{(2\sqrt{7} - 0)^2 + \left(0 - 4\sqrt{\frac{7}{3}}\right)^2} \\ &= \sqrt{28 + \frac{112}{3}} = \sqrt{\frac{196}{3}} = \frac{14}{\sqrt{3}} \times \frac{\sqrt{3}}{\sqrt{3}} = \frac{14\sqrt{3}}{3} \end{aligned}$$

21. Any point on the ellipse

$$\frac{x^2}{a^2} + \frac{y^2}{b^2} = 1 \text{ be } P(a \cos \theta, b \sin \theta)$$

The equation of tangent at point P is given by

$$\frac{x \cos \theta}{a} + \frac{y \sin \theta}{b} = 1$$

The equation of line perpendicular to tangent is

$$\frac{x \sin \theta}{b} - \frac{y \cos \theta}{a} = \lambda$$

Since, it passes through the focus $(ae, 0)$, then

$$\frac{ae \sin \theta}{b} - 0 = \lambda$$

$$\Rightarrow \lambda = \frac{ae \sin \theta}{b}$$

$$\therefore \text{Equation is } \frac{x \sin \theta}{b} - \frac{y \cos \theta}{a} = \frac{ae \sin \theta}{b} \quad \dots(i)$$

Equation of line joining centre and point of contact $P(a \cos \theta, b \sin \theta)$ is

$$y = \frac{b}{a} (\tan \theta) x \quad \dots(ii)$$

Point of intersection Q of Eqs. (i) and (ii) has x coordinate, $\frac{a}{e}$. Hence, Q lies on the corresponding directrix $x = \frac{a}{e}$.

472 Ellipse

22. Let the coordinates of $A \equiv (a \cos \theta, b \sin \theta)$, so that the coordinates of

$$B = \{a \cos (\theta + 2\pi / 3), a \sin (\theta + 2\pi / 3)\}$$

$$\text{and } C = \{a \cos (\theta + 4\pi / 3), a \sin (\theta + 4\pi / 3)\}$$

According to the given condition, coordinates of P are $(a \cos \theta, b \sin \theta)$ and that of Q are $\{a \cos (\theta + 2\pi / 3), b \sin (\theta + 2\pi / 3)\}$ and that of R are

$$a \cos (\theta + 4\pi / 3), b \sin (\theta + 4\pi / 3)$$

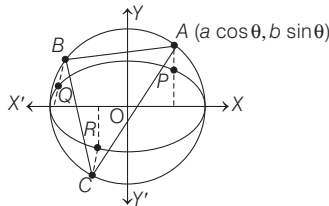

\therefore it is given that P, Q, R are on the same side of X -axis as A, B and C

Equation of the normal to the ellipse at P is

$$\frac{ax}{\cos \theta} - \frac{by}{\sin \theta} = a^2 - b^2$$

$$\text{or } ax \sin \theta - by \cos \theta = \frac{1}{2} (a^2 - b^2) \sin 2\theta \quad \dots(i)$$

Equation of normal to the ellipse at Q is

$$\begin{aligned} ax \sin \left(\theta + \frac{2\pi}{3} \right) - by \cos \left(\theta + \frac{2\pi}{3} \right) \\ = \frac{1}{2} (a^2 - b^2) \sin \left(2\theta + \frac{4\pi}{3} \right) \quad \dots(ii) \end{aligned}$$

Equation of normal to the ellipse at R is

$$\begin{aligned} ax \sin (\theta + 4\pi / 3) - by \cos (\theta + 4\pi / 3) \\ = \frac{1}{2} (a^2 - b^2) \sin (2\theta + 8\pi / 3) \quad \dots(iii) \end{aligned}$$

$$\begin{aligned} \text{But } \sin (\theta + 4\pi / 3) &= \sin (2\pi + \theta - 2\pi / 3) \\ &= \sin (\theta - 2\pi / 3) \end{aligned}$$

$$\begin{aligned} \text{and } \cos (\theta + 4\pi / 3) &= \cos (2\pi + \theta - 2\pi / 3) \\ &= \cos (\theta - 2\pi / 3) \end{aligned}$$

$$\begin{aligned} \text{and } \sin (2\theta + 8\pi / 3) &= \sin (4\pi + 2\theta - 4\pi / 3) \\ &= \sin (2\theta - 4\pi / 3) \end{aligned}$$

Now, Eq. (iii) can be written as

$$\begin{aligned} ax \sin (\theta - 2\pi / 3) - by \cos (\theta - 2\pi / 3) \\ = \frac{1}{2} (a^2 - b^2) \sin (2\theta - 4\pi / 3) \quad \dots(iv) \end{aligned}$$

For the lines (i), (ii) and (iv) to be concurrent, we must have the determinant

$$\Delta_1 = \begin{vmatrix} a \sin \theta & -b \cos \theta & \frac{1}{2} (a^2 - b^2) \sin 2\theta \\ a \sin \left(\theta + \frac{2\pi}{3} \right) & -b \cos \left(\theta + \frac{2\pi}{3} \right) & \frac{1}{2} (a^2 - b^2) \sin (2\theta + 4\pi / 3) \\ a \sin \left(\theta - \frac{2\pi}{3} \right) & -b \cos \left(\theta - \frac{2\pi}{3} \right) & \frac{1}{2} (a^2 - b^2) \sin (2\theta - 4\pi / 3) \end{vmatrix} = 0$$

Thus, lines (i), (ii) and (iv) are concurrent.

23. Given, $x^2 + 4y^2 = 4$ or $\frac{x^2}{4} + \frac{y^2}{1} = 1$... (i)

Equation of any tangent to the ellipse on (i) can be written as

$$\frac{x}{2} \cos \theta + y \sin \theta = 1 \quad \dots(ii)$$

Equation of second ellipse is

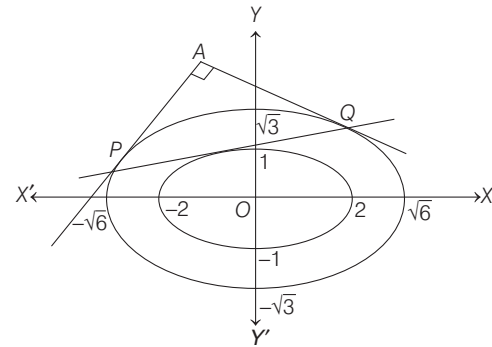

$$x^2 + 2y^2 = 6$$

$$\Rightarrow \frac{x^2}{6} + \frac{y^2}{3} = 1 \quad \dots(iii)$$

Suppose the tangents at P and Q meet at $A(h, k)$. Equation of the chord of contact of the tangents through $A(h, k)$ is

$$\frac{hx}{6} + \frac{ky}{3} = 1 \quad \dots(iv)$$

But Eqs. (iv) and (ii) represent the same straight line, so comparing Eqs. (iv) and (ii), we get

$$\frac{h/6}{\cos \theta / 2} = \frac{k/3}{\sin \theta} = \frac{1}{1}$$

$$\Rightarrow h = 3 \cos \theta \text{ and } k = 3 \sin \theta$$

Therefore, coordinates of A are $(3 \cos \theta, 3 \sin \theta)$.

Now, the joint equation of the tangents at A is given by $T^2 = SS_1$,

$$\text{i.e. } \left(\frac{hx}{6} + \frac{ky}{3} - 1 \right)^2 = \left(\frac{x^2}{6} + \frac{y^2}{3} - 1 \right) \left(\frac{h^2}{6} + \frac{k^2}{3} - 1 \right) \quad \dots(v)$$

$$\text{In Eq. (v), coefficient of } x^2 = \frac{h^2}{36} - \frac{1}{6} \left(\frac{h^2}{6} + \frac{k^2}{3} - 1 \right)$$

$$= \frac{h^2}{36} - \frac{h^2}{36} - \frac{k^2}{18} + \frac{1}{6} = \frac{1}{6} - \frac{k^2}{18}$$

$$\text{and coefficient of } y^2 = \frac{k^2}{9} - \frac{1}{3} \left(\frac{h^2}{6} + \frac{k^2}{3} - 1 \right)$$

$$= \frac{k^2}{9} - \frac{h^2}{18} - \frac{k^2}{9} + \frac{1}{3} = -\frac{h^2}{18} + \frac{1}{3}$$

Again, coefficient of x^2 + coefficient of y^2

$$= -\frac{1}{18} (h^2 + k^2) + \frac{1}{6} + \frac{1}{3}$$

$$= -\frac{1}{18} (9 \cos^2 \theta + 9 \sin^2 \theta) + \frac{1}{2}$$

$$= -\frac{9}{18} + \frac{1}{2} = 0$$

which shows that two lines represent by Eq. (v) are at right angles to each other.

24. Let the coordinates of point P be $(a \cos \theta, b \sin \theta)$.

Then, equation of tangent at P is

$$\frac{x}{a} \cos \theta + \frac{y}{b} \sin \theta = 1 \quad \dots(i)$$

We have, d = length of perpendicular from O to the tangent at P

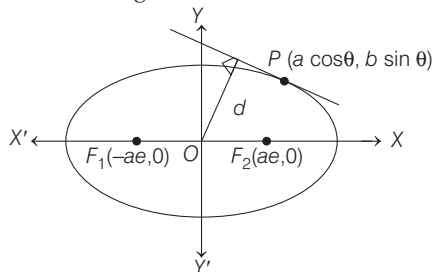

$$d = \frac{|0 + 0 - 1|}{\sqrt{\frac{\cos^2 \theta}{a^2} + \frac{\sin^2 \theta}{b^2}}} \Rightarrow \frac{1}{d} = \sqrt{\frac{\cos^2 \theta}{a^2} + \frac{\sin^2 \theta}{b^2}}$$

$$\Rightarrow \frac{1}{d^2} = \frac{\cos^2 \theta}{a^2} + \frac{\sin^2 \theta}{b^2}$$

We have to prove $(PF_1 - PF_2)^2 = 4a^2 \left(1 - \frac{b^2}{d^2}\right)$

Now, $RHS = 4a^2 \left(1 - \frac{b^2}{d^2}\right) = 4a^2 - \frac{4a^2 b^2}{d^2}$

$$= 4a^2 - 4a^2 b^2 \left(\frac{\cos^2 \theta}{a^2} + \frac{\sin^2 \theta}{b^2}\right)$$

$$= 4a^2 - 4b^2 \cos^2 \theta - 4a^2 \sin^2 \theta$$

$$= 4a^2(1 - \sin^2 \theta) - 4b^2 \cos^2 \theta$$

$$= 4a^2 \cos^2 \theta - 4b^2 \cos^2 \theta$$

$$= 4 \cos^2 \theta (a^2 - b^2) = 4 \cos^2 \theta \cdot a^2 e^2 \quad [\because e = \sqrt{1 - (b/a)^2}]$$

Again, $PF_1 = e|a \cos \theta + a/e| = a|e \cos \theta + 1|$
 $= a(e \cos \theta + 1)$ [$\because -1 \leq \cos \theta \leq 1$ and $0 < e < 1$]

Similarly, $PF_2 = a(1 - e \cos \theta)$

Therefore, $LHS = (PF_1 - PF_2)^2$

$$= [a(e \cos \theta + 1) - a(1 - e \cos \theta)]^2$$

$$= (ae \cos \theta + a - a + ae \cos \theta)^2$$

$$= (2ae \cos \theta)^2 = 4a^2 e^2 \cos^2 \theta$$

Hence, $LHS = RHS$

- 25.

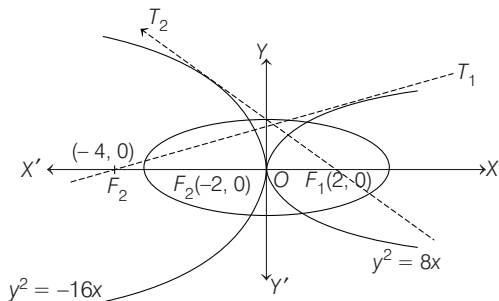

Tangent to P_1 passes through $(2f_2, 0)$ i.e. $(-4, 0)$.

$$\therefore T_1: y = m_1 x + \frac{2}{m_1} \Rightarrow 0 = -4m_1 + \frac{2}{m_1}$$

$$\Rightarrow m_1^2 = 1/2 \quad \dots(i)$$

Also, tangent to P_2 passes through $(f_1, 0)$ i.e. $(2, 0)$.

$$\Rightarrow T_2: y = m_2 x + \frac{(-4)}{m_2} \Rightarrow 0 = 2m_2 - \frac{4}{m_2}$$

$$\Rightarrow m_2^2 = 2 \quad \dots(ii)$$

$$\therefore \frac{1}{m_1^2} + m_2^2 = 2 + 2 = 4$$

Topic 3 Equation of Chord of Contact, Chord Bisected at a Given Point and Diameter

1. Equation of AB is $y - 0 = -\frac{1}{3}(x - 3)$

$$x + 3y - 3 = 0$$

$$\Rightarrow |x + 3y - 3|^2 = 10 [(x - 3)^2 + (y - 4)^2]$$

On solving, we are getting

$$9x^2 + y^2 - 6xy - 54x - 62y + 241 = 0$$

2. Equation of AB is

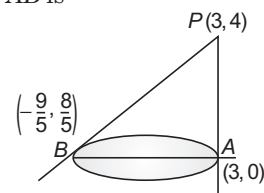

$$y - 0 = \frac{\frac{8}{5}}{-\frac{9}{5} - 3}(x - 3) = \frac{8}{-24}(x - 3) \Rightarrow y = -\frac{1}{3}(x - 3)$$

$$\Rightarrow x + 3y = 3 \quad \dots(i)$$

Equation of the straight line perpendicular to AB through P is

$$3x - y = 5$$

Equation of PA is $2x - 3 = 0$

The equation of straight line perpendicular to PA

through $B\left(-\frac{9}{5}, \frac{8}{5}\right)$ is $y = \frac{8}{5}$.

Hence, the orthocentre is $\left(\frac{11}{5}, \frac{8}{5}\right)$.

3. Figure is self-explanatory.

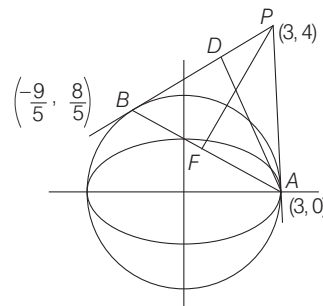

19

Hyperbola

Topic 1 Equation of Hyperbola and Focal Chord

Objective Questions I (Only one correct option)

1. A hyperbola having the transverse axis of length $\sqrt{2}$ has the same foci as that of the ellipse $3x^2 + 4y^2 = 12$, then this hyperbola does not pass through which of the following points? (2020 Main, 3 Sep I)

- (a) $\left(\frac{1}{\sqrt{2}}, 0\right)$ (b) $\left(-\sqrt{\frac{3}{2}}, 1\right)$
(c) $\left(1, -\frac{1}{\sqrt{2}}\right)$ (d) $\left(\sqrt{\frac{3}{2}}, \frac{1}{\sqrt{2}}\right)$

2. Let P be the point of intersection of the common tangents to the parabola $y^2 = 12x$ and the hyperbola $8x^2 - y^2 = 8$. If S and S' denotes the foci of the hyperbola where S lies on the positive X -axis then P divides SS' in a ratio (2019 Main, 12 April I)

- (a) 13 : 11 (b) 14 : 13
(c) 5 : 4 (d) 2 : 1

3. If $5x + 9 = 0$ is the directrix of the hyperbola $16x^2 - 9y^2 = 144$, then its corresponding focus is (2019 Main, 10 April II)

- (a) $\left(-\frac{5}{3}, 0\right)$ (b) $(-5, 0)$ (c) $\left(\frac{5}{3}, 0\right)$ (d) $(5, 0)$

4. If a directrix of a hyperbola centred at the origin and passing through the point $(4, -2\sqrt{3})$ is $5x = 4\sqrt{5}$ and its eccentricity is e , then (2019 Main, 10 April I)

- (a) $4e^4 - 12e^2 - 27 = 0$ (b) $4e^4 - 24e^2 + 27 = 0$
(c) $4e^4 + 8e^2 - 35 = 0$ (d) $4e^4 - 24e^2 + 35 = 0$

5. If the vertices of a hyperbola be at $(-2, 0)$ and $(2, 0)$ and one of its foci be at $(-3, 0)$, then which one of the following points does not lie on this hyperbola? (2019 Main, 12 Jan I)

- (a) $(2\sqrt{6}, 5)$ (b) $(6, 5\sqrt{2})$
(c) $(4, \sqrt{15})$ (d) $(-6, 2\sqrt{10})$

6. If a hyperbola has length of its conjugate axis equal to 5 and the distance between its foci is 13, then the eccentricity of the hyperbola is (2019 Main, 11 Jan II)

- (a) $\frac{13}{12}$ (b) 2
(c) $\frac{13}{8}$ (d) $\frac{13}{6}$

7. Let $S = \left\{ (x, y) \in \mathbb{R}^2 : \frac{y^2}{1+r} - \frac{x^2}{1-r} = 1 \right\}$,

where $r \neq \pm 1$. Then, S represents (2019 Main, 10 Jan II)

- (a) a hyperbola whose eccentricity is $\frac{2}{\sqrt{1-r}}$, when $0 < r < 1$.
(b) a hyperbola whose eccentricity is $\frac{2}{\sqrt{r+1}}$, when $0 < r < 1$.
(c) an ellipse whose eccentricity is $\sqrt{\frac{2}{r+1}}$, when $r > 1$.
(d) an ellipse whose eccentricity is $\frac{1}{\sqrt{r+1}}$, when $r > 1$.

8. A hyperbola has its centre at the origin, passes through the point $(4, 2)$ and has transverse axis of length 4 along the X -axis. Then the eccentricity of the hyperbola is (2019 Main, 9 Jan II)

- (a) 2 (b) $\frac{2}{\sqrt{3}}$ (c) $\frac{3}{2}$ (d) $\sqrt{3}$

9. Let $0 < \theta < \frac{\pi}{2}$. If the eccentricity of the hyperbola $\frac{x^2}{\cos^2 \theta} - \frac{y^2}{\sin^2 \theta} = 1$ is greater than 2, then the length of its latus rectum lies in the interval (2019 Main, 9 Jan I)

- (a) $\left(1, \frac{3}{2}\right]$ (b) $(3, \infty)$ (c) $\left(\frac{3}{2}, 2\right]$ (d) $(2, 3]$

10. The eccentricity of the hyperbola whose length of the latusrectum is equal to 8 and the length of its conjugate axis is equal to half of the distance between its foci, is (2017 Main)

- (a) $\frac{4}{3}$ (b) $\frac{4}{\sqrt{3}}$ (c) $\frac{2}{\sqrt{3}}$ (d) $\sqrt{3}$

11. Consider a branch of the hyperbola

$$x^2 - 2y^2 - 2\sqrt{2}x - 4\sqrt{2}y - 6 = 0$$

with vertex at the point A . Let B be one of the end points of its latusrectum. If C is the focus of the hyperbola nearest to the point A , then the area of the ΔABC is (2008, 3M)

- (a) $1 - \sqrt{2/3}$ sq unit (b) $\sqrt{3/2} - 1$ sq unit
(c) $1 + \sqrt{2/3}$ sq unit (d) $\sqrt{3/2} + 1$ sq unit

12. A hyperbola, having the transverse axis of length $2\sin\theta$, is confocal with the ellipse $3x^2 + 4y^2 = 12$. Then, its equation is (2007, 3M)
- (a) $x^2\operatorname{cosec}^2\theta - y^2\sec^2\theta = 1$
 (b) $x^2\sec^2\theta - y^2\operatorname{cosec}^2\theta = 1$
 (c) $x^2\sin^2\theta - y^2\cos^2\theta = 1$
 (d) $x^2\cos^2\theta - y^2\sin^2\theta = 1$
13. If e_1 is the eccentricity of the ellipse $\frac{x^2}{16} + \frac{y^2}{25} = 1$ and e_2 is the eccentricity of the hyperbola passing through the foci of the ellipse and $e_1e_2 = 1$, then equation of the hyperbola is (2006, 3M)
- (a) $\frac{x^2}{9} - \frac{y^2}{16} = 1$ (b) $\frac{x^2}{16} - \frac{y^2}{9} = -1$
 (c) $\frac{x^2}{9} - \frac{y^2}{25} = 1$ (d) None of these
14. For hyperbola $\frac{x^2}{\cos^2\alpha} - \frac{y^2}{\sin^2\alpha} = 1$, which of the following remains constant with change in ' α '? (2003, 1M)
- (a) Abscissae of vertices (b) Abscissae of foci
 (c) Eccentricity (d) Directrix
15. The equation $\frac{x^2}{1-r} - \frac{y^2}{1+r} = 1, |r| < 1$ represents (1981, 2M)
- (a) an ellipse (b) a hyperbola
 (c) a circle (d) None of these

Objective Questions II

(One or more than one correct option)

16. Let the eccentricity of the hyperbola $\frac{x^2}{a^2} - \frac{y^2}{b^2} = 1$ be reciprocal to that of the ellipse $x^2 + 4y^2 = 4$. If the hyperbola passes through a focus of the ellipse, then
- (a) the equation of the hyperbola is $\frac{x^2}{3} - \frac{y^2}{2} = 1$ (2011)
 (b) a focus of the hyperbola is $(2, 0)$
 (c) the eccentricity of the hyperbola is $\sqrt{\frac{5}{3}}$
 (d) the equation of the hyperbola is $x^2 - 3y^2 = 3$

Topic 2 Equation of Tangent and Normal

Objective Questions I (Only one correct option)

1. If a hyperbola passes through the point $P(10, 16)$ and it has vertices at $(\pm 6, 0)$, then the equation of the normal to it at P is (2020 Main, 8 Jan II)
- (a) $3x + 4y = 94$ (b) $x + 2y = 42$
 (c) $2x + 5y = 100$ (d) $x + 3y = 58$
2. The equation of a common tangent to the curves, $y^2 = 16x$ and $xy = -4$, is (2019 Main, 12 April II)
- (a) $x - y + 4 = 0$ (b) $x + y + 4 = 0$
 (c) $x - 2y + 16 = 0$ (d) $2x - y + 2 = 0$

17. An ellipse intersects the hyperbola $2x^2 - 2y^2 = 1$ orthogonally. The eccentricity of the ellipse is reciprocal to that of the hyperbola. If the axes of the ellipse are along the coordinate axes, then (2009)
- (a) equation of ellipse is $x^2 + 2y^2 = 2$
 (b) the foci of ellipse are $(\pm 1, 0)$
 (c) equation of ellipse is $x^2 + 2y^2 = 4$
 (d) the foci of ellipse are $(\pm\sqrt{2}, 0)$

Analytical & Descriptive Question

18. A variable straight line of slope 4 intersects the hyperbola $xy = 1$ at two points. Find the locus of the point which divides the line segment between these two points in the ratio 1 : 2. (1997, 5M)

Match the List

19. Let $H: \frac{x^2}{a^2} - \frac{y^2}{b^2} = 1$, where $a > b > 0$, be a hyperbola in the XY -plane whose conjugate axis LM subtends an angle of 60° at one of its vertices N . Let the area of the $\triangle LMN$ be $4\sqrt{3}$.

	List-I	List-II
P.	The length of the conjugate axis of H is	1. 8
Q.	The eccentricity of H is	2. $\frac{4}{\sqrt{3}}$
R.	The distance between the foci of H is	3. $\frac{2}{\sqrt{3}}$
S.	The length of the latus rectum of H is	4. 4

The correct option is

(2018 Adv.)

- (a) $P \rightarrow 4; Q \rightarrow 2; R \rightarrow 1; S \rightarrow 3$
 (b) $P \rightarrow 4; Q \rightarrow 3; R \rightarrow 1; S \rightarrow 2$
 (c) $P \rightarrow 4; Q \rightarrow 1; R \rightarrow 3; S \rightarrow 2$
 (d) $P \rightarrow 3; Q \rightarrow 4; R \rightarrow 2; S \rightarrow 1$

3. If the line $y = mx + 7\sqrt{3}$ is normal to the hyperbola $\frac{x^2}{24} - \frac{y^2}{18} = 1$, then a value of m is (2019 Main, 9 April I)
- (a) $\frac{3}{\sqrt{5}}$ (b) $\frac{\sqrt{15}}{2}$ (c) $\frac{2}{\sqrt{5}}$ (d) $\frac{\sqrt{5}}{2}$
4. If the eccentricity of the standard hyperbola passing through the point $(4, 6)$ is 2, then the equation of the tangent to the hyperbola at $(4, 6)$ is (2019 Main, 8 April II)
- (a) $3x - 2y = 0$ (b) $x - 2y + 8 = 0$
 (c) $2x - y - 2 = 0$ (d) $2x - 3y + 10 = 0$

476 Hyperbola

5. The equation of a tangent to the hyperbola $4x^2 - 5y^2 = 20$ parallel to the line $x - y = 2$ is
(2019 Main, 10 Jan I)

(a) $x - y - 3 = 0$ (b) $x - y + 9 = 0$
(c) $x - y + 1 = 0$ (d) $x - y + 7 = 0$

6. Tangents are drawn to the hyperbola $4x^2 - y^2 = 36$ at the points P and Q . If these tangents intersect at the point $T(0, 3)$, then the area (in sq units) of ΔPTQ is

(a) $45\sqrt{5}$ (b) $54\sqrt{3}$ (2018 Main)
(c) $60\sqrt{3}$ (d) $36\sqrt{5}$

7. If a hyperbola passes through the point $P(\sqrt{2}, \sqrt{3})$ and has foci at $(\pm 2, 0)$, then the tangent to this hyperbola at P also passes through the point (2017 Main)

(a) $(3\sqrt{2}, 2\sqrt{3})$ (b) $(2\sqrt{2}, 3\sqrt{3})$
(c) $(\sqrt{3}, \sqrt{2})$ (d) $(-\sqrt{2}, -\sqrt{3})$

8. Let $P(6, 3)$ be a point on the hyperbola $\frac{x^2}{a^2} - \frac{y^2}{b^2} = 1$. If the normal at the point P intersects the X -axis at $(9, 0)$, then the eccentricity of the hyperbola is (2011)

(a) $\sqrt{\frac{5}{2}}$ (b) $\sqrt{\frac{3}{2}}$ (c) $\sqrt{2}$ (d) $\sqrt{3}$

9. If the line $2x + \sqrt{6}y = 2$ touches the hyperbola $x^2 - 2y^2 = 4$, then the point of contact is (2004, 1M)

(a) $(-2, \sqrt{6})$ (b) $(-5, 2\sqrt{6})$ (c) $(\frac{1}{2}, \frac{1}{\sqrt{6}})$ (d) $(4, -\sqrt{6})$

10. Let $P(a \sec \theta, b \tan \theta)$ and $Q(a \sec \phi, b \tan \phi)$, where $\theta + \phi = \frac{\pi}{2}$, be two points on the hyperbola $\frac{x^2}{a^2} - \frac{y^2}{b^2} = 1$.

If (h, k) is the point of the intersection of the normals at P and Q , then k is equal to (1999, 2M)

(a) $\frac{a^2 + b^2}{a}$ (b) $-\left(\frac{a^2 + b^2}{a}\right)$ (c) $\frac{a^2 + b^2}{b}$ (d) $-\left(\frac{a^2 + b^2}{b}\right)$

Objective Questions II

(One or more than one correct option)

11. Let a and b be positive real numbers such that $a > 1$ and $b < a$. Let P be a point in the first quadrant that lies on the hyperbola $\frac{x^2}{a^2} - \frac{y^2}{b^2} = 1$. Suppose the tangent to the hyperbola at P passes through the point $(1, 0)$, and suppose the normal to the hyperbola at P cuts off equal intercepts on the coordinate axes. Let Δ denote the area of the triangle formed by the tangent at P , the normal at P and the X -axis. If e denotes the eccentricity of the hyperbola, then which of the following statements is/are TRUE? (2020 Adv.)

(a) $1 < e < \sqrt{2}$ (b) $\sqrt{2} < e < 2$
(c) $\Delta = a^4$ (d) $\Delta = b^4$

12. If $2x - y + 1 = 0$ is a tangent to the hyperbola $\frac{x^2}{a^2} - \frac{y^2}{16} = 1$ then which of the following CANNOT be sides of a right angled triangle? (2017 Adv.)

(a) $a, 4, 1$ (b) $2a, 4, 1$ (c) $a, 4, 2$ (d) $2a, 8, 1$

13. Consider the hyperbola $H: x^2 - y^2 = 1$ and a circle S with centre $N(x_2, 0)$. Suppose that H and S touch each other at a point $P(x_1, y_1)$ with $x_1 > 1$ and $y_1 > 0$. The common tangent to H and S at P intersects the X -axis at point M . If (l, m) is the centroid of ΔPMN , then the correct expression(s) is/are (2015 Adv.)

(a) $\frac{dl}{dx_1} = 1 - \frac{1}{3x_1^2}$ for $x_1 > 1$

(b) $\frac{dm}{dx_1} = \frac{x_1}{3(\sqrt{x_1^2 - 1})}$ for $x_1 > 1$

(c) $\frac{dl}{dx_1} = 1 + \frac{1}{3x_1^2}$ for $x_1 > 1$

(d) $\frac{dm}{dy_1} = \frac{1}{3}$ for $y_1 > 0$

14. Tangents are drawn to the hyperbola $\frac{x^2}{9} - \frac{y^2}{4} = 1$, parallel to the straight line $2x - y = 1$. The points of contacts of the tangents on the hyperbola are (2012)

(a) $(\frac{9}{2\sqrt{2}}, \frac{1}{\sqrt{2}})$ (b) $(-\frac{9}{2\sqrt{2}}, -\frac{1}{\sqrt{2}})$

(c) $(3\sqrt{3}, -2\sqrt{2})$ (d) $(-3\sqrt{3}, 2\sqrt{2})$

Passage Based Problems

The circle $x^2 + y^2 - 8x = 0$ and hyperbola $\frac{x^2}{9} - \frac{y^2}{4} = 1$ intersect at the points A and B . (2010)

15. Equation of the circle with AB as its diameter is

(a) $x^2 + y^2 - 12x + 24 = 0$

(b) $x^2 + y^2 + 12x + 24 = 0$

(c) $x^2 + y^2 + 24x - 12 = 0$

(d) $x^2 + y^2 - 24x - 12 = 0$

16. Equation of a common tangent with positive slope to the circle as well as to the hyperbola is

(a) $2x - 5\sqrt{y} - 20 = 0$

(b) $2x - \sqrt{5}y + 4 = 0$

(c) $3x - 4y + 8 = 0$

(d) $4x - 3y + 4 = 0$

Integer & Numerical Answer Type Question

17. The line $2x + y = 1$ is tangent to the hyperbola $\frac{x^2}{a^2} - \frac{y^2}{b^2} = 1$. If this line passes through the point of intersection of the nearest directrix and the X -axis, then the eccentricity of the hyperbola is..... (2010)

Topic 3 Equation of Chord of Contact, Chord Bisected Diameter, Asymptote and Rectangular Hyperbola

Objective Question I (Only one correct option)

1. If $x=9$ is the chord of contact of the hyperbola $x^2 - y^2 = 9$, then the equation of the corresponding pair of tangents is (1999, 2M)
- (a) $9x^2 - 8y^2 + 18x - 9 = 0$ (b) $9x^2 - 8y^2 - 18x + 9 = 0$
 (c) $9x^2 - 8y^2 - 18x - 9 = 0$ (d) $9x^2 - 8y^2 + 18x + 9 = 0$

- (a) $x_1 + x_2 + x_3 + x_4 = 0$
 (b) $y_1 + y_2 + y_3 + y_4 = 0$
 (c) $x_1 x_2 x_3 x_4 = c^4$
 (d) $y_1 y_2 y_3 y_4 = c^4$

Objective Question II

(Only one or more than one correct option)

2. If the circle $x^2 + y^2 = a^2$ intersects the hyperbola $xy = c^2$ in four points $P(x_1, y_1), Q(x_2, y_2), R(x_3, y_3), S(x_4, y_4)$, then (1998, 2M)

Analytical & Descriptive Question

3. Tangents are drawn from any point on the hyperbola $\frac{x^2}{9} - \frac{y^2}{4} = 1$ to the circle $x^2 + y^2 = 9$. Find the locus of mid-point of the chord of contact. (2005, 4M)

Answers

Topic 1

1. (d) 2. (c) 3. (b) 4. (d)
 5. (b) 6. (a) 7. (c) 8. (b)
 9. (b) 10. (c) 11. (b) 12. (a)
 13. (b) 14. (b) 15. (b) 16. (b, d)
 17. (a, b) 18. $16x^2 + y^2 + 10xy = 2$ 19. (b)

Topic 2

1. (c) 2. (a) 3. (c) 4. (c)

5. (c) 6. (a) 7. (b) 8. (b)
 9. (d) 10. (d) 11. (a, d) 12. (a, c, d)
 13. (a, b, d) 14. (a, b) 15. (a) 16. (b)
 17. (2)

Topic 3

1. (b) 2. (a, b, c, d) 3. $\frac{x^2}{9} - \frac{y^2}{4} = \frac{(x^2 + y^2)^2}{81}$

Hints & Solutions

Topic 1 Equation of Hyperbola and Focal Chord

1. Equation of given ellipse is

$$3x^2 + 4y^2 = 12 \Rightarrow \frac{x^2}{4} + \frac{y^2}{3} = 1 \quad \dots (i)$$

\therefore Eccentricity of ellipse (i) is $e_1 = \sqrt{1 - \frac{3}{4}} = \frac{1}{2}$

\therefore Coordinate of foci is $(\pm 1, 0)$.

Now, it is given that length of the transverse axis of hyperbola is $\sqrt{2}$, so $\frac{\sqrt{2}}{2} e_2 = 1$, where e_2 is the eccentricity of the hyperbola.

So, $e_2 = \sqrt{2}$

\therefore Given hyperbola is rectangular hyperbola and its equation is

$$\frac{x^2}{\left(\frac{1}{\sqrt{2}}\right)^2} - \frac{y^2}{\left(\frac{1}{\sqrt{2}}\right)^2} = 1$$

$$\Rightarrow x^2 - y^2 = \frac{1}{2} \quad \dots (ii)$$

So, from the given options point $\left(\frac{\sqrt{3}}{\sqrt{2}}, \frac{1}{\sqrt{2}}\right)$ does not pass

through the hyperbola (ii).

Hence, option (d) is correct.

2. Equation of given parabola $y^2 = 12x$... (i)

and hyperbola $8x^2 - y^2 = 8$... (ii)

Now, equation of tangent to parabola $y^2 = 12x$ having slope 'm' is $y = mx + \frac{3}{m}$... (iii)

and equation of tangent to hyperbola

$\frac{x^2}{1} - \frac{y^2}{8} = 1$ having slope 'm' is

$$y = mx \pm \sqrt{1^2 m^2 - 8} \quad \dots (iv)$$

Since, tangents (iii) and (iv) represent the same line

$$\therefore m^2 - 8 = \left(\frac{3}{m}\right)^2$$

$$\Rightarrow m^4 - 8m^2 - 9 = 0$$

$$\Rightarrow (m^2 - 9)(m^2 + 1) = 0$$

$$\Rightarrow m = \pm 3.$$

478 Hyperbola

Now, equation of common tangents to the parabola (i) and hyperbola (ii) are $y = 3x + 1$ and $y = -3x - 1$

\therefore Point 'P' is point of intersection of above common tangents,

$$\therefore P(-1/3, 0)$$

and focus of hyperbola $S(3, 0)$ and $S'(-3, 0)$.

$$\text{Thus, the required ratio} = \frac{PS}{PS'} = \frac{3 + 1/3}{3 - 1/3} = \frac{10}{8} = \frac{5}{4}$$

3. Equation of given hyperbola is

$$16x^2 - 9y^2 = 144$$

$$\Rightarrow \frac{x^2}{9} - \frac{y^2}{16} = 1 \quad \dots(i)$$

So, the eccentricity of Eq. (i)

$$e = \sqrt{1 + \frac{16}{9}} = \frac{5}{3}$$

$$[\because \text{the eccentricity (e) of the hyperbola } \frac{x^2}{a^2} - \frac{y^2}{b^2} = 1 \text{ is } \frac{e}{\sqrt{1 + (b/a)^2}}$$

and given directrix is $5x + 9 = 0 \Rightarrow x = -9/5$

$$\text{So, corresponding focus is } \left(-3\left(\frac{5}{3}\right), 0\right) = (-5, 0)$$

4. Let the equation of hyperbola is

$$\frac{x^2}{a^2} - \frac{y^2}{b^2} = 1 \quad \dots(i)$$

Since, equation of given directrix is $5x = 4\sqrt{5}$

$$\text{so } 5\left(\frac{a}{e}\right) = 4\sqrt{5} \quad [\because \text{equation of directrix is } x = \frac{a}{e}]$$

$$\Rightarrow \frac{a}{e} = \frac{4}{\sqrt{5}} \quad \dots(ii)$$

and hyperbola (i) passes through point $(4, -2\sqrt{3})$

$$\text{so, } \frac{16}{a^2} - \frac{12}{b^2} = 1 \quad \dots(iii)$$

$$\text{The eccentricity } e = \sqrt{1 + \frac{b^2}{a^2}} \Rightarrow e^2 = 1 + \frac{b^2}{a^2}$$

$$\Rightarrow a^2e^2 - a^2 = b^2 \quad \dots(iv)$$

From Eqs. (ii) and (iv), we get

$$\frac{16}{5}e^4 - \frac{16}{5}e^2 = b^2 \quad \dots(v)$$

From Eqs. (ii) and (iii), we get

$$\frac{16}{5}e^2 - \frac{12}{b^2} = 1 \Rightarrow \frac{5}{e^2} - \frac{12}{b^2} = 1$$

$$\Rightarrow \frac{12}{b^2} = \frac{5}{e^2} - 1 \Rightarrow \frac{12}{b^2} = \frac{5 - e^2}{e^2} \Rightarrow b^2 = \frac{12e^2}{5 - e^2} \quad \dots(vi)$$

From Eqs. (v) and (vi), we get

$$16e^4 - 16e^2 = 5\left(\frac{12e^2}{5 - e^2}\right) \Rightarrow 16(e^2 - 1)(5 - e^2) = 60$$

$$\Rightarrow 4(5e^2 - e^4 - 5 + e^2) = 15$$

$$\Rightarrow 4e^4 - 24e^2 + 35 = 0$$

5. The vertices of hyperbola are given as $(\pm 2, 0)$ and one of its foci is at $(-3, 0)$.

$$\therefore (a, 0) = (2, 0) \text{ and } (-ae, 0) = (-3, 0)$$

On comparing x -coordinates both sides, we get

$$\Rightarrow a = 2 \text{ and } -ae = -3$$

$$\Rightarrow 2e = 3 \Rightarrow e = \frac{3}{2}$$

$$\text{Also, } \frac{9}{4} = 1 + \frac{b^2}{4} \Rightarrow b^2 = 5 \quad \left[\because e^2 = 1 + \frac{b^2}{a^2} \right]$$

So, equation of the hyperbola is

$$\frac{x^2}{4} - \frac{y^2}{5} = 1 \quad \dots(i)$$

The point $(6, 5\sqrt{2})$ from the given options does not satisfy the above equation of hyperbola.

6. We know that in $\frac{x^2}{a^2} - \frac{y^2}{b^2} = 1$, where $b^2 = a^2(e^2 - 1)$, the length of conjugate axis is $2b$ and distance between the foci is $2ae$.

\therefore According to the problem, $2b = 5$ and $2ae = 13$

$$\text{Now, } b^2 = a^2(e^2 - 1)$$

$$\Rightarrow \left(\frac{5}{2}\right)^2 = a^2e^2 - a^2$$

$$\Rightarrow \frac{25}{4} = \frac{(2ae)^2}{4} - a^2$$

$$\Rightarrow \frac{25}{4} = \frac{169}{4} - a^2 \quad [\because 2ae = 13]$$

$$\Rightarrow a^2 = \frac{169 - 25}{4} = \frac{144}{4} = 36$$

$$\Rightarrow a = 6$$

$$\text{Now, } 2ae = 13$$

$$\Rightarrow 2 \times 6 \times e = 13$$

$$\Rightarrow e = \frac{13}{12}$$

7. Given, $S = \left\{ (x, y) \in R^2 : \frac{y^2}{1+r} - \frac{x^2}{1-r} = 1 \right\}$
 $= \left\{ (x, y) \in R^2 : \frac{y^2}{1+r} + \frac{x^2}{r-1} = 1 \right\}$

$$\text{For } r > 1, \frac{y^2}{1+r} + \frac{x^2}{r-1} = 1, \text{ represents a vertical ellipse.}$$

$$[\because \text{for } r > 1, r-1 < r+1 \text{ and } r-1 > 0]$$

$$\text{Now, eccentricity (e) = } \sqrt{1 - \frac{r-1}{r+1}}$$

$$\left[\because \text{For } \frac{x^2}{a^2} + \frac{y^2}{b^2} = 1, a < b, e = \sqrt{1 - \frac{a^2}{b^2}} \right]$$

$$= \sqrt{\frac{(r+1) - (r-1)}{r+1}}$$

$$= \sqrt{\frac{2}{r+1}}$$

8. Equation of hyperbola is given by

$$\frac{x^2}{a^2} - \frac{y^2}{b^2} = 1$$

∴ Length of transverse axis = $2a = 4$

∴ $a = 2$

Thus, $\frac{x^2}{4} - \frac{y^2}{b^2} = 1$ is the equation of hyperbola

∴ It passes through $(4, 2)$.

$$\therefore \frac{16}{4} - \frac{4}{b^2} = 1 \Rightarrow 4 - \frac{4}{b^2} = 1 \Rightarrow b^2 = \frac{4}{3} \Rightarrow b = \frac{2}{\sqrt{3}}$$

Now, eccentricity,

$$e = \sqrt{1 + \frac{b^2}{a^2}} = \sqrt{1 + \frac{\frac{4}{3}}{4}} = \sqrt{1 + \frac{1}{3}} = \frac{2}{\sqrt{3}}$$

9. For the hyperbola $\frac{x^2}{a^2} - \frac{y^2}{b^2} = 1$,

$$e = \sqrt{1 + \frac{b^2}{a^2}}$$

∴ For the given hyperbola,

$$e = \sqrt{1 + \frac{\sin^2 \theta}{\cos^2 \theta}} > 2$$

$$(\because a^2 = \cos^2 \theta \text{ and } b^2 = \sin^2 \theta)$$

$$\Rightarrow 1 + \tan^2 \theta > 4$$

$$\Rightarrow \tan^2 \theta > 3$$

$$\Rightarrow \tan \theta \in (-\infty, -\sqrt{3}) \cup (\sqrt{3}, \infty)$$

$$[x^2 > 3 \Rightarrow |x| > \sqrt{3} \Rightarrow x \in (-\infty, -\sqrt{3}) \cup (\sqrt{3}, \infty)]$$

$$\text{But } \theta \in \left(0, \frac{\pi}{2}\right) \Rightarrow \tan \theta \in (\sqrt{3}, \infty)$$

$$\Rightarrow \theta \in \left(\frac{\pi}{3}, \frac{\pi}{2}\right)$$

Now, length of latusrectum

$$= \frac{2b^2}{a} = 2 \frac{\sin^2 \theta}{\cos \theta} = 2 \sin \theta \tan \theta$$

Since, both $\sin \theta$ and $\tan \theta$ are increasing functions in $\left(\frac{\pi}{3}, \frac{\pi}{2}\right)$.

∴ Least value of latusrectum is

$$= 2 \sin \frac{\pi}{3} \cdot \tan \frac{\pi}{3} = 2 \cdot \frac{\sqrt{3}}{2} \cdot \sqrt{3} = 3 \quad \left(\text{at } \theta = \frac{\pi}{3}\right)$$

and greatest value of latusrectum is $< \infty$

Hence, latusrectum length $\in (3, \infty)$

10. We have, $\frac{2b^2}{a} = 8$ and $2b = ae$

$$\Rightarrow b^2 = 4a \text{ and } 2b = ae$$

$$\text{Consider, } 2b = ae$$

$$\Rightarrow 4b^2 = a^2 e^2$$

$$\Rightarrow 4a^2(e^2 - 1) = a^2 e^2$$

$$\Rightarrow 4e^2 - 4 = e^2 \quad [\because a \neq 0]$$

$$\Rightarrow 3e^2 = 4$$

$$\Rightarrow e = \frac{2}{\sqrt{3}} \quad [\because e > 0]$$

11. Given equation can be rewritten as focal chord

$$\frac{(x - \sqrt{2})^2}{4} - \frac{(y + \sqrt{2})^2}{2} = 1$$

$$\text{For point } A(x, y), e = \sqrt{1 + \frac{2}{4}} = \sqrt{\frac{3}{2}}$$

$$\Rightarrow x - \sqrt{2} = 2 \Rightarrow x = 2 + \sqrt{2}$$

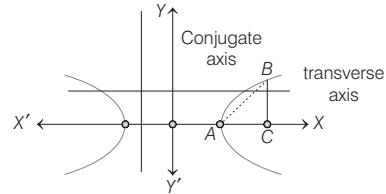

$$\text{For point } C(x, y), x - \sqrt{2} = ae = \sqrt{6} \Rightarrow x = \sqrt{6} + \sqrt{2}$$

$$\text{Now, } AC = \sqrt{6} + \sqrt{2} - 2 - \sqrt{2} = \sqrt{6} - 2$$

$$\text{and } BC = \frac{b^2}{a} = \frac{2}{2} = 1$$

$$\therefore \text{Area of } \Delta ABC = \frac{1}{2} \times (\sqrt{6} - 2) \times 1 = \sqrt{\frac{3}{2}} - 1 \text{ sq unit}$$

12. The given ellipse is

$$\frac{x^2}{4} + \frac{y^2}{3} = 1 \Rightarrow a = 2, b = \sqrt{3}$$

$$\therefore 3 = 4(1 - e^2) \Rightarrow e = \frac{1}{2}$$

$$\text{So, } ae = 2 \times \frac{1}{2} = 1$$

Hence, the eccentricity e_1 of the hyperbola is given by

$$e_1 = \operatorname{cosec} \theta \quad [\because ae = e \sin \theta]$$

$$\Rightarrow b^2 = \sin^2 \theta (\operatorname{cosec}^2 \theta - 1) = \cos^2 \theta$$

Hence, equation of hyperbola is

$$\frac{x^2}{\sin^2 \theta} - \frac{y^2}{\cos^2 \theta} = 1 \text{ or } x^2 \operatorname{cosec}^2 \theta - y^2 \sec^2 \theta = 1.$$

13. The eccentricity of $\frac{x^2}{16} + \frac{y^2}{25} = 1$ is

$$e_1 = \sqrt{1 - \frac{16}{25}} = \frac{3}{5}$$

$$\therefore e_2 = \frac{5}{3} \quad [\because e_1 e_2 = 1]$$

⇒ Foci of ellipse $(0, \pm 3)$

$$\Rightarrow \text{Equation of hyperbola is } \frac{x^2}{16} - \frac{y^2}{9} = -1.$$

14. Given equation of hyperbola is $\frac{x^2}{\cos^2 \alpha} - \frac{y^2}{\sin^2 \alpha} = 1$

$$\text{Here, } a^2 = \cos^2 \alpha \text{ and } b^2 = \sin^2 \alpha$$

$$[\text{i.e. comparing with standard equation } \frac{x^2}{a^2} - \frac{y^2}{b^2} = 1]$$

We know that, foci $= (\pm ae, 0)$

$$\text{where, } ae = \sqrt{a^2 + b^2} = \sqrt{\cos^2 \alpha + \sin^2 \alpha} = 1$$

⇒ Foci $= (\pm 1, 0)$

where, vertices are $(\pm \cos \alpha, 0)$.

480 Hyperbola

Eccentricity, $ae = 1$ or $e = \frac{1}{\cos \alpha}$

Hence, foci remains constant with change in α .

15. Given equation is $\frac{x^2}{1-r} - \frac{y^2}{1+r} = 1$, where $|r| < 1$

$\Rightarrow 1-r$ is (+ve) and $1+r$ is (+ve)

\therefore Given equation is of the form $\frac{x^2}{a^2} - \frac{y^2}{b^2} = 1$.

Hence, it represents a hyperbola when $|r| < 1$.

16. Here, equation of ellipse is $\frac{x^2}{4} + \frac{y^2}{1} = 1$

$\Rightarrow e^2 = 1 - \frac{b^2}{a^2} = 1 - \frac{1}{4} = \frac{3}{4}$

$\therefore e = \frac{\sqrt{3}}{2}$ and focus $(\pm ae, 0) \Rightarrow (\pm \sqrt{3}, 0)$

For hyperbola $\frac{x^2}{a^2} - \frac{y^2}{b^2} = 1$, $e_1^2 = 1 + \frac{b^2}{a^2}$

where, $e_1^2 = \frac{1}{e^2} = \frac{4}{3} \Rightarrow 1 + \frac{b^2}{a^2} = \frac{4}{3}$

$\therefore \frac{b^2}{a^2} = \frac{1}{3}$... (i)

and hyperbola passes through $(\pm \sqrt{3}, 0)$

$\Rightarrow \frac{3}{a^2} = 1 \Rightarrow a^2 = 3$... (ii)

From Eqs. (i) and (ii), $b^2 = 1$... (iii)

\therefore Equation of hyperbola is $\frac{x^2}{3} - \frac{y^2}{1} = 1$

Focus is $(\pm ae_1, 0) \Rightarrow (\pm \sqrt{3} \cdot \frac{2}{\sqrt{3}}, 0) \Rightarrow (\pm 2, 0)$

Hence, (b) and (d) are correct answers.

17. Given, $2x^2 - 2y^2 = 1$

$\Rightarrow \frac{x^2}{\left(\frac{1}{2}\right)} - \frac{y^2}{\left(\frac{1}{2}\right)} = 1$... (i)

Eccentricity of hyperbola $= \sqrt{2}$

So, eccentricity of ellipse $= 1/\sqrt{2}$

Let equation of ellipse be

$\frac{x^2}{a^2} + \frac{y^2}{b^2} = 1$ [where $a > b$]

$\therefore \frac{1}{\sqrt{2}} = \sqrt{1 - \frac{b^2}{a^2}} \Rightarrow \frac{b^2}{a^2} = \frac{1}{2}$

$\Rightarrow a^2 = 2b^2 \Rightarrow x^2 + 2y^2 = 2b^2$... (ii)

Let ellipse and hyperbola intersect at

$A\left(\frac{1}{\sqrt{2}} \sec \theta, \frac{1}{\sqrt{2}} \tan \theta\right)$

On differentiating Eq. (i), we get

$4x - 4y \frac{dy}{dx} = 0 \Rightarrow \frac{dy}{dx} = \frac{x}{y}$

$\frac{dy}{dx} \Big|_{\text{at } A} = \frac{\sec \theta}{\tan \theta} = \operatorname{cosec} \theta$

and on differentiating Eq. (ii), we get

$2x + 4y \frac{dy}{dx} = 0 \Rightarrow \frac{dy}{dx} \Big|_{\text{at } A} = -\frac{x}{2y} = -\frac{1}{2} \operatorname{cosec} \theta$

Since, ellipse and hyperbola are orthogonal.

$\therefore -\frac{1}{2} \operatorname{cosec}^2 \theta = -1 \Rightarrow \operatorname{cosec}^2 \theta = 2 \Rightarrow \theta = \pm \frac{\pi}{4}$

$\therefore A\left(1, \frac{1}{\sqrt{2}}\right)$ or $\left(1, -\frac{1}{\sqrt{2}}\right)$

Form Eq. (ii), $1 + 2\left(\frac{1}{\sqrt{2}}\right)^2 = 2b^2$

$\Rightarrow b^2 = 1$

Equation of ellipse is $x^2 + 2y^2 = 2$.

Coordinates of foci $(\pm ae, 0) = \left(\pm \sqrt{2} \cdot \frac{1}{\sqrt{2}}, 0\right) = (\pm 1, 0)$

If major axis is along Y-axis, then

$\frac{1}{\sqrt{2}} = \sqrt{1 - \frac{a^2}{b^2}} \Rightarrow b^2 = 2a^2$

$\therefore 2x^2 + y^2 = 2a^2$

$\Rightarrow Y' = -\frac{2x}{y}$

$\Rightarrow y' \left(\frac{1}{\sqrt{2}} \sec \theta, \frac{1}{\sqrt{2}} \tan \theta\right) = \frac{-2}{\sin \theta}$

As ellipse and hyperbola are orthogonal

$\therefore -\frac{2}{\sin \theta} \cdot \operatorname{cosec} \theta = -1$

$\Rightarrow \operatorname{cosec}^2 \theta = \frac{1}{2} \Rightarrow \theta = \pm \frac{\pi}{4}$

$\therefore 2x^2 + y^2 = 2a^2$

$\Rightarrow 2 + \frac{1}{2} = 2a^2 \Rightarrow a^2 = \frac{5}{4}$

$\therefore 2x^2 + y^2 = \frac{5}{2}$, corresponding foci are $(0, \pm 1)$.

Hence, option (a) and (b) are correct.

18. Let $y = 4x + c$ meets $xy = 1$ at two points A and B.

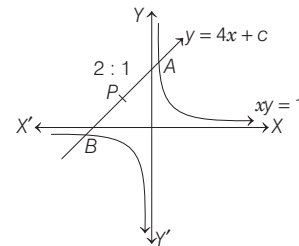

i.e. $A(t_1, 1/t_1), B(t_2, 1/t_2)$

\therefore Coordinates of P are

$\left(\frac{2t_1 + t_2}{2 + 1}, \frac{2 \cdot \frac{1}{t_1} + 1 \cdot \frac{1}{t_2}}{2 + 1}\right) = (h, k)$ [say]

$$\therefore h = \frac{2t_1 + t_2}{3} \text{ and } k = \frac{2t_2 + t_1}{3t_1t_2} \quad \dots(i)$$

Also, $\left(t_1, \frac{1}{t_1}\right)$ and $\left(t_2, \frac{1}{t_2}\right)$ lie on $y = 4x + c$.

$$\Rightarrow \frac{\frac{1}{t_2} - \frac{1}{t_1}}{t_2 - t_1} = \frac{1}{t_1t_2} = 4 \text{ or } t_1t_2 = -1/4 \quad \dots(ii)$$

From Eq. (i), $t_1 = 2h + \frac{k}{4}$
and $t_1 = h - \frac{k}{2} \quad \dots(iii)$

From Eqs. (ii) and (iii), $\left(-h - \frac{k}{2}\right)\left(2h + \frac{k}{4}\right) = -\frac{1}{4}$
 $\Rightarrow -\left(\frac{2h+k}{2}\right)\left(\frac{8h+k}{4}\right) = -\frac{1}{4}$

$\Rightarrow (2h+k)(8h+k) = 2$
 $\Rightarrow 16h^2 + k^2 + 10hk = 2$

Hence, required locus is $16x^2 + y^2 + 10xy = 2$.

19. We have,

Equation of hyperbola

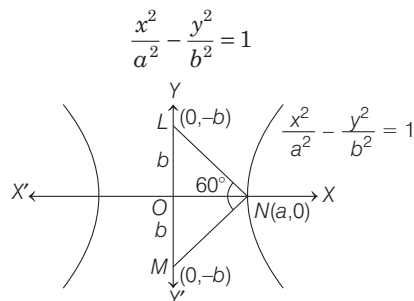

It is given,

$$\angle LNM = 60^\circ$$

and Area of $\triangle LMN = 4\sqrt{3}$

Now, $\triangle LMN$ is an equilateral triangle whose sides is $2b$

[$\because \triangle LON \cong \triangle MOL$; $\therefore \angle NLO = \angle NMO = 60^\circ$]

$$\therefore \text{Area of } \triangle LMN = \frac{\sqrt{3}}{4} (2b)^2$$

$$\Rightarrow 4\sqrt{3} = \sqrt{3}b^2 \Rightarrow b = 2$$

Also, area of $\triangle LMN = \frac{1}{2} a(2b) = ab$

$$\Rightarrow 4\sqrt{3} = a(2) \Rightarrow a = 2\sqrt{3}$$

(P) Length of conjugate axis = $2b = 2(2) = 4$

(Q) Eccentricity $(e) = \sqrt{1 + \frac{b^2}{a^2}} = \sqrt{1 + \frac{4}{12}} = \frac{4}{2\sqrt{3}} = \frac{2}{\sqrt{3}}$

(R) Distance between the foci = $2ae = 2 \times 2\sqrt{3} \times \frac{2}{\sqrt{3}} = 8$

(S) The length of latusrectum = $\frac{2b^2}{a} = \frac{2(4)}{2\sqrt{3}} = \frac{4}{\sqrt{3}}$

$P \rightarrow 4; Q \rightarrow 3; R \rightarrow 1; S \rightarrow 2$

Topic 2 Equation of Tangent and Normal

1. Since, the vertices of hyperbola on X-axis at $(\pm 6, 0)$, so equation of hyperbola we can assume as $\frac{x^2}{a^2} - \frac{y^2}{b^2} = 1$ and

$$|a| = 6$$

and hyperbola passes through point $P(10, 16)$ so

$$\frac{(10)^2}{6^2} - \frac{(16)^2}{b^2} = 1$$

$$\Rightarrow \frac{(16)^2}{b^2} = \frac{100 - 36}{36} = \frac{64}{36}$$

$$\Rightarrow b^2 = \frac{36 \times 256}{64} = 144$$

So, equation of hyperbola is $\frac{x^2}{36} - \frac{y^2}{144} = 1$, and the equation of normal to hyperbola at point P is

$$\frac{36x}{10} + \frac{144y}{16} = 36 + 144$$

$$\Rightarrow \frac{18}{5}x + 9y = 180$$

$$\Rightarrow 2x + 5y = 100$$

Hence, option (c) is correct.

2. **Key Idea** An equation of tangent having slope 'm' to parabola $y^2 = 4ax$ is $y = mx + \frac{a}{m}$.

Given equation of curves are

$$y^2 = 16x \text{ (parabola)} \quad \dots(i)$$

and $xy = -4$ (rectangular hyperbola) $\dots(ii)$

Clearly, equation of tangent having slope 'm' to parabola

(i) is $y = mx + \frac{4}{m} \quad \dots(iii)$

Now, eliminating y from Eqs. (ii) and (iii), we get

$$x\left(mx + \frac{4}{m}\right) = -4 \Rightarrow mx^2 + \frac{4}{m}x + 4 = 0,$$

which will give the points of intersection of tangent and rectangular hyperbola.

Since, line $y = mx + \frac{4}{m}$ is also a tangent to the rectangular hyperbola.

\therefore Discriminant of quadratic equation $mx^2 + \frac{4}{m}x + 4 = 0$, should be zero.

[\because there will be only one point of intersection]

$$\Rightarrow D = \left(\frac{4}{m}\right)^2 - 4(m)(4) = 0$$

$$\Rightarrow m^3 = 1 \Rightarrow m = 1$$

So, equation of required tangent is $y = x + 4$.

3. Given equation of hyperbola, is $\frac{x^2}{24} - \frac{y^2}{18} = 1 \quad \dots(i)$

Since, the equation of the normals of slope m to the hyperbola $\frac{x^2}{a^2} - \frac{y^2}{b^2} = 1$, are given by $y = mx \mp \frac{m(a^2 + b^2)}{\sqrt{a^2 - b^2m^2}}$

482 Hyperbola

∴ Equation of normals of slope m , to the hyperbola (i), are

$$y = mx \pm \frac{m(24+18)}{\sqrt{24-m^2(18)}} \quad \dots(\text{ii})$$

∴ Line $y = mx + 7\sqrt{3}$ is normal to hyperbola (i)

∴ On comparing with Eq. (ii), we get

$$\pm \frac{m(42)}{\sqrt{24-18m^2}} = 7\sqrt{3}$$

$$\Rightarrow \pm \frac{6m}{\sqrt{24-18m^2}} = \sqrt{3}$$

$$\Rightarrow \frac{36m^2}{24-18m^2} = 3 \quad [\text{squaring both sides}]$$

$$\Rightarrow 12m^2 = 24 - 18m^2$$

$$\Rightarrow 30m^2 = 24$$

$$\Rightarrow 5m^2 = 4 \Rightarrow m = \pm \frac{2}{\sqrt{5}}$$

4. Let the equation of standard hyperbola is

$$\frac{x^2}{a^2} - \frac{y^2}{b^2} = 1 \quad \dots(\text{i})$$

Now, eccentricity of hyperbola is

$$\sqrt{1 + \frac{b^2}{a^2}} = 2 \quad (\text{given})$$

$$\Rightarrow a^2 + b^2 = 4a^2$$

$$\Rightarrow b^2 = 3a^2 \quad \dots(\text{ii})$$

Since, hyperbola (i) passes through the point (4, 6)

$$\therefore \frac{16}{a^2} - \frac{36}{b^2} = 1 \quad \dots(\text{iii})$$

On solving Eqs. (ii) and (iii), we get

$$a^2 = 4 \text{ and } b^2 = 12 \quad \dots(\text{iv})$$

Now, equation of tangent to hyperbola (i) at point (4, 6), is

$$\frac{4x}{a^2} - \frac{6y}{b^2} = 1$$

$$\Rightarrow \frac{4x}{4} - \frac{6y}{12} = 1 \quad [\text{from Eq. (iv)}]$$

$$\Rightarrow x - \frac{y}{2} = 1 \Rightarrow 2x - y - 2 = 0$$

5. Given equation of hyperbola is

$$4x^2 - 5y^2 = 20$$

which can be rewritten as

$$\Rightarrow \frac{x^2}{5} - \frac{y^2}{4} = 1$$

The line $x - y = 2$ has slope, $m = 1$

∴ Slope of tangent parallel to this line = 1

We know equation of tangent to hyperbola $\frac{x^2}{a^2} - \frac{y^2}{b^2} = 1$

having slope m is given by

$$y = mx \pm \sqrt{a^2 m^2 - b^2}$$

Here, $a^2 = 5$, $b^2 = 4$ and $m = 1$

∴ Required equation of tangent is

$$\Rightarrow y = x \pm \sqrt{5-4}$$

$$\Rightarrow y = x \pm 1 \Rightarrow x - y + 1 = 0$$

6. Tangents are drawn to the hyperbola $4x^2 - y^2 = 36$ at the point P and Q .

Tangent intersects at point $T(0, 3)$

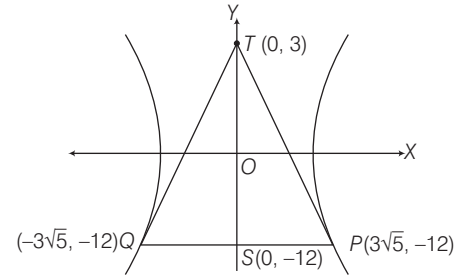

Clearly, PQ is chord of contact.

∴ Equation of PQ is $-3y = 36$

$$\Rightarrow y = -12$$

Solving the curve $4x^2 - y^2 = 36$ and $y = -12$,

we get $x = \pm 3\sqrt{5}$

$$\text{Area of } \Delta PQT = \frac{1}{2} \times PQ \times ST = \frac{1}{2} (6\sqrt{5} \times 15) = 45\sqrt{5}$$

7. Let the equation of hyperbola be $\frac{x^2}{a^2} - \frac{y^2}{b^2} = 1$.

$$\therefore ae = 2 \Rightarrow a^2 e^2 = 4$$

$$\Rightarrow a^2 + b^2 = 4 \Rightarrow b^2 = 4 - a^2$$

$$\therefore \frac{x^2}{a^2} - \frac{y^2}{4-a^2} = 1$$

Since, $(\sqrt{2}, \sqrt{3})$ lie on hyperbola.

$$\therefore \frac{2}{a^2} - \frac{3}{4-a^2} = 1$$

$$\Rightarrow 8 - 2a^2 - 3a^2 = a^2(4 - a^2)$$

$$\Rightarrow 8 - 5a^2 = 4a^2 - a^4$$

$$\Rightarrow a^4 - 9a^2 + 8 = 0$$

$$\Rightarrow (a^4 - 8)(a^4 - 1) = 0 \Rightarrow a^4 = 8, a^4 = 1$$

$$\therefore a = 1$$

Now, equation of hyperbola is $\frac{x^2}{1} - \frac{y^2}{3} = 1$.

∴ Equation of tangent at $(\sqrt{2}, \sqrt{3})$ is given by

$$\sqrt{2}x - \frac{\sqrt{3}y}{3} = 1 \Rightarrow \sqrt{2}x - \frac{y}{\sqrt{3}} = 1$$

which passes through the point $(2\sqrt{2}, 3\sqrt{3})$.

8. Equation of normal to hyperbola at (x_1, y_1) is

$$\frac{a^2 x}{x_1} + \frac{b^2 y}{y_1} = (a^2 + b^2)$$

$$\therefore \text{At } (6, 3) = \frac{a^2 x}{6} + \frac{b^2 y}{3} = (a^2 + b^2)$$

$$\therefore \text{It passes through } (9, 0). \Rightarrow \frac{a^2 \cdot 9}{6} = a^2 + b^2$$

$$\Rightarrow \frac{3a^2}{2} - a^2 = b^2 \Rightarrow \frac{a^2}{b^2} = 2$$

$$\therefore e^2 = 1 + \frac{b^2}{a^2} = 1 + \frac{1}{2} \Rightarrow e = \sqrt{\frac{3}{2}}$$

9. The equation of tangent at (x_1, y_1) is $xx_1 - 2yy_1 = 4$, which is same as $2x + \sqrt{6}y = 2$.

$$\therefore \frac{x_1}{2} = -\frac{2y_1}{\sqrt{6}} = \frac{4}{2}$$

$$\Rightarrow x_1 = 4 \quad \text{and} \quad y_1 = -\sqrt{6}$$

Thus, the point of contact is $(4, -\sqrt{6})$.

10. Firstly, we obtain the slope of normal to $\frac{x^2}{a^2} - \frac{y^2}{b^2} = 1$ at $(a \sec \theta, b \tan \theta)$. On differentiating w.r.t. x , we get

$$\frac{2x}{a^2} - \frac{2y}{b^2} \times \frac{dy}{dx} = 0 \Rightarrow \frac{dy}{dx} = \frac{b^2 x}{a^2 y}$$

Slope for normal at the point $(a \sec \theta, b \tan \theta)$ will be

$$-\frac{a^2 b \tan \theta}{b^2 a \sec \theta} = -\frac{a}{b} \sin \theta$$

\therefore Equation of normal at $(a \sec \theta, b \tan \theta)$ is

$$y - b \tan \theta = -\frac{a}{b} \sin \theta (x - a \sec \theta)$$

$$\Rightarrow (a \sin \theta) x + by = (a^2 + b^2) \tan \theta$$

$$\Rightarrow ax + b \operatorname{cosec} \theta = (a^2 + b^2) \sec \theta \quad \dots(i)$$

Similarly, equation of normal to $\frac{x^2}{a^2} - \frac{y^2}{b^2} = 1$ at

$$(a \sec \phi, b \tan \phi) \text{ is } ax + by \operatorname{cosec} \phi = (a^2 + b^2) \sec \phi \quad \dots(ii)$$

On subtracting Eq. (ii) from Eq. (i), we get

$$b(\operatorname{cosec} \theta - \operatorname{cosec} \phi) y = (a^2 + b^2)(\sec \theta - \sec \phi)$$

$$\Rightarrow y = \frac{a^2 + b^2}{b} \cdot \frac{\sec \theta - \sec \phi}{\operatorname{cosec} \theta - \operatorname{cosec} \phi}$$

$$\text{But } \frac{\sec \theta - \sec \phi}{\operatorname{cosec} \theta - \operatorname{cosec} \phi} = \frac{\sec \theta - \sec(\pi/2 - \theta)}{\operatorname{cosec} \theta - \operatorname{cosec}(\pi/2 - \theta)}$$

$$[\because \phi + \theta = \pi/2]$$

$$= \frac{\sec \theta - \operatorname{cosec} \theta}{\sec \theta - \sec \theta} = -1$$

$$\text{Thus, } y = -\left(\frac{a^2 + b^2}{b}\right), \text{ i.e. } k = -\left(\frac{a^2 + b^2}{b}\right)$$

11. Equation of given hyperbola is

$$\frac{x^2}{a^2} - \frac{y^2}{b^2} = 1, \quad a > b \text{ and } a > 1$$

Let point $P(a \sec \theta, b \tan \theta)$ on the hyperbola in first quadrant i.e., $Q \in \left(0, \frac{\pi}{2}\right)$.

Now equation of tangent to the hyperbola at point P is

$$\frac{x \sec \theta}{a} - \frac{y \tan \theta}{b} = 1 \quad \dots(i)$$

\therefore The tangent (i) passes through point $A(1, 0)$

$$\text{So, } a = \sec \theta > 1. \quad \dots(ii)$$

and equation of normal to the hyperbola at point P having slope is $\frac{b \sec \theta}{a \tan \theta}$, as normal cuts off equal intercepts on the coordinate axes, so slope must be -1 .

$$\text{Therefore, } \frac{b \sec \theta}{a \tan \theta} = -1$$

$$\Rightarrow b = -\tan \theta \quad \{\text{from Eq. (ii)}\}$$

\therefore The eccentricity of hyperbola

$$e = \sqrt{1 + \frac{b^2}{a^2}} = \sqrt{1 + \sin^2 \theta}$$

$$\therefore 1 < e < \sqrt{2}, \text{ as } \theta \in \left(0, \frac{\pi}{2}\right)$$

And the area of required triangle is, which is isosceles is

$$\Delta = \frac{1}{2} (AP)^2 = \frac{1}{2} [(1 - \sec^2 \theta)^2 + \tan^4 \theta]$$

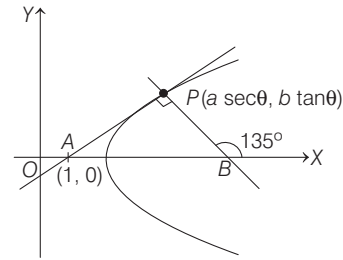

$$= \frac{1}{2} (2 \tan^4 \theta) = \tan^4 \theta = b^4.$$

12. Tangent $\equiv 2x - y + 1 = 0$

$$\text{Hyperbola } \equiv \frac{x^2}{a^2} - \frac{y^2}{16} = 1$$

$$\text{It point } \equiv (a \sec \theta, 4 \tan \theta),$$

$$\text{tangent } \equiv \frac{x \sec \theta}{a} - \frac{y \tan \theta}{4} = 1$$

On comparing, we get $\sec \theta = -2a$

$$\tan \theta = -4 \Rightarrow 4a^2 - 16 = 1$$

$$\therefore a = \frac{\sqrt{17}}{2}$$

Substitute the value of a in option (a), (b), (c) and (d).

13.

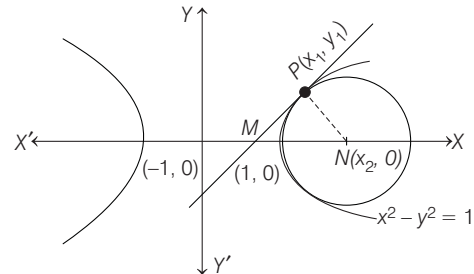

Equation of family of circles touching hyperbola at (x_1, y_1) is $(x - x_1)^2 + (y - y_1)^2 + \lambda(x x_1 - y y_1 - 1) = 0$

Now, its centre is $(x_2, 0)$.

$$\therefore \left[\frac{-(\lambda x_1 - 2x_1)}{2}, \frac{-(-2y_1 - \lambda y_1)}{2} \right] = (x_2, 0)$$

$$\Rightarrow 2y_1 + \lambda y_1 = 0 \Rightarrow \lambda = -2$$

$$\text{and } 2x_1 - \lambda x_1 = 2x_2 \Rightarrow x_2 = 2x_1$$

484 Hyperbola

$$\therefore P(x_1, \sqrt{x_1^2 - 1}) \text{ and } N(x_2, 0) = (2x_1, 0)$$

As tangent intersect X-axis at $M\left(\frac{1}{x_1}, 0\right)$.

Centroid of $\Delta PMN = (l, m)$

$$\Rightarrow \left(\frac{3x_1 + \frac{1}{x_1}}{3}, \frac{y_1 + 0 + 0}{3} \right) = (l, m)$$

$$\Rightarrow l = \frac{3x_1 + \frac{1}{x_1}}{3}$$

On differentiating w.r.t. x_1 , we get $\frac{dl}{dx_1} = \frac{3 - \frac{1}{x_1^2}}{3}$

$$\Rightarrow \frac{dl}{dx_1} = 1 - \frac{1}{3x_1^2}, \text{ for } x_1 > 1 \text{ and } m = \frac{\sqrt{x_1^2 - 1}}{3}$$

On differentiating w.r.t. x_1 , we get

$$\frac{dm}{dx_1} = \frac{2x_1}{2 \times 3\sqrt{x_1^2 - 1}} = \frac{x_1}{3\sqrt{x_1^2 - 1}} \text{ for } x_1 > 1$$

Also, $m = \frac{y_1}{3}$

On differentiating w.r.t. y_1 , we get $\frac{dm}{dy_1} = \frac{1}{3}$, for $y_1 > 0$

14. **PLAN** Equation of tangent to $\frac{x^2}{a^2} - \frac{y^2}{b^2} = 1$ is $y = mx \pm \sqrt{a^2m^2 - b^2}$

Description of Situation If two straight lines

$$a_1x + b_1y + c_1 = 0$$

and $a_2x + b_2y + c_2 = 0$ are identical. Then, $\frac{a_1}{a_2} = \frac{b_1}{b_2} = \frac{c_1}{c_2}$

Equation of tangent, parallel to $y = 2x - 1$ is

$$y = 2x \pm \sqrt{9(4) - 4}$$

$$\therefore y = 2x \pm \sqrt{32} \quad \dots(i)$$

The equation of tangent at (x_1, y_1) is

$$\frac{xx_1}{9} - \frac{yy_1}{4} = 1 \quad \dots(ii)$$

From Eqs. (i) and (ii),

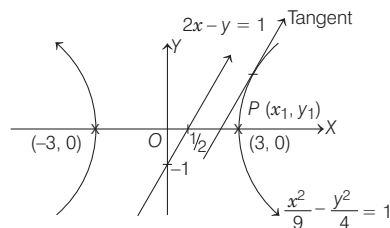

$$\frac{2}{9} = \frac{-1}{-y_1} = \frac{\pm\sqrt{32}}{1}$$

$$\Rightarrow x_1 = -\frac{9}{2\sqrt{2}} \text{ and } y_1 = -\frac{1}{\sqrt{2}}$$

$$\text{or } x_1 = \frac{9}{2\sqrt{2}}, y_1 = \frac{1}{\sqrt{2}}$$

15. The equation of the hyperbola is $\frac{x^2}{9} - \frac{y^2}{4} = 1$ and that of circle is $x^2 + y^2 - 8x = 0$

For their points of intersection, $\frac{x^2}{9} + \frac{x^2 - 8x}{4} = 1$

$$\Rightarrow 4x^2 + 9x^2 - 72x = 36$$

$$\Rightarrow 13x^2 - 72x - 36 = 0$$

$$\Rightarrow 13x^2 - 78x + 6x - 36 = 0$$

$$\Rightarrow 13x(x - 6) + 6(x - 6) = 0$$

$$\Rightarrow x = 6, x = -\frac{13}{6}$$

$x = -\frac{13}{6}$ not acceptable.

Now, for $x = 6$, $y = \pm 2\sqrt{3}$

Required equation is, $(x - 6)^2 + (y + 2\sqrt{3})(y - 2\sqrt{3}) = 0$

$$\Rightarrow x^2 - 12x + y^2 + 24 = 0$$

$$\Rightarrow x^2 + y^2 - 12x + 24 = 0$$

16. Equation of tangent to hyperbola having slope m is

$$y = mx + \sqrt{9m^2 - 4} \quad \dots(i)$$

Equation of tangent to circle is

$$y = m(x - 4) + \sqrt{16m^2 + 16} \quad \dots(ii)$$

Eqs. (i) and (ii) will be identical for $m = \frac{2}{\sqrt{5}}$ satisfy.

\therefore Equation of common tangent is $2x - \sqrt{5}y + 4 = 0$.

17. On substituting $\left(\frac{a}{e}, 0\right)$ in $y = -2x + 1$, we get

$$0 = -\frac{2a}{e} + 1$$

$$\Rightarrow \frac{a}{e} = \frac{1}{2}$$

Also, $y = -2x + 1$ is tangent to hyperbola.

$$\therefore 1 = 4a^2 - b^2$$

$$\Rightarrow \frac{1}{a^2} = 4 - (e^2 - 1)$$

$$\Rightarrow \frac{4}{e^2} = 5 - e^2$$

$$\Rightarrow e^4 - 5e^2 + 4 = 0$$

$$\Rightarrow (e^2 - 4)(e^2 - 1) = 0$$

$$\Rightarrow e = 2, e = 1$$

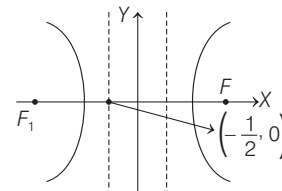

$e = 1$ gives the conic as parabola. But conic is given as hyperbola, hence $e = 2$.

Topic 3 Equation of Chord of Contact, Chord Bisected Diameter, Asymptote and Rectangular Hyperbola

1. Let (h, k) be a point whose chord of contact with respect to hyperbola $x^2 - y^2 = 9$ is $x = 9$.

We know that, chord of contact of (h, k) with respect to hyperbola $x^2 - y^2 = 9$ is $T = 0$.

$$\Rightarrow h \cdot x + k(-y) - 9 = 0$$

$$\therefore hx - ky - 9 = 0$$

But it is the equation of the line $x = 9$.

This is possible when $h = 1, k = 0$ (by comparing both equations).

Again equation of pair of tangents is

$$T^2 = SS_1$$

$$\Rightarrow (x - 9)^2 = (x^2 - y^2 - 9)(1^2 - 0^2 - 9)$$

$$\Rightarrow x^2 - 18x + 81 = (x^2 - y^2 - 9)(-8)$$

$$\Rightarrow x^2 - 18x + 81 = -8x^2 + 8y^2 + 72$$

$$\Rightarrow 9x^2 - 8y^2 - 18x + 9 = 0$$

2. It is given that,

$$x^2 + y^2 = a^2 \quad \dots(i)$$

and $xy = c^2 \quad \dots(ii)$

We obtain $x^2 + c^4/x^2 = a^2$

$$\Rightarrow x^4 - a^2x^2 + c^4 = 0 \quad \dots(iii)$$

Now, x_1, x_2, x_3, x_4 will be roots of Eq. (iii).

Therefore, $\Sigma x_1 = x_1 + x_2 + x_3 + x_4 = 0$

and product of the roots $x_1x_2x_3x_4 = c^4$

Similarly, $y_1 + y_2 + y_3 + y_4 = 0$

and $y_1y_2y_3y_4 = c^4$

Hence, all options are correct.

3. Let any point on the hyperbola is $(3 \sec \theta, 2 \tan \theta)$.

\therefore Chord of contact of the circle $x^2 + y^2 = 9$ with respect to the point $(3 \sec \theta, 2 \tan \theta)$ is,

$$(3 \sec \theta)x + (2 \tan \theta)y = 9 \quad \dots(i)$$

Let (x_1, y_1) be the mid-point of the chord of contact.

\Rightarrow Equation of chord in mid-point form is

$$xx_1 + yy_1 = x_1^2 + y_1^2 \quad \dots(ii)$$

Since, Eqs. (i) and (ii) are identically equal.

$$\therefore \frac{3 \sec \theta}{x_1} = \frac{2 \tan \theta}{y_1}$$

$$= \frac{9}{x_1^2 + y_1^2}$$

$$\Rightarrow \sec \theta = \frac{9x_1}{3(x_1^2 + y_1^2)}$$

and $\tan \theta = \frac{9y_1}{2(x_1^2 + y_1^2)}$

Thus, eliminating ' θ ' from above equation, we get

$$\frac{81x_1^2}{9(x_1^2 + y_1^2)^2} - \frac{81y_1^2}{4(x_1^2 + y_1^2)^2} = 1$$

[$\because \sec^2 \theta - \tan^2 \theta = 1$]

$$\therefore \text{Required locus is } \frac{x^2}{9} - \frac{y^2}{4} = \frac{(x^2 + y^2)^2}{81}$$

20

Trigonometrical Ratios and Identities

Topic 1 Based on Trigonometric Formulae

Objective Questions I (Only one correct option)

1. The value of $\cos^3\left(\frac{\pi}{8}\right) \cdot \cos\left(\frac{3\pi}{8}\right) + \sin^3\left(\frac{\pi}{8}\right) \cdot \sin\left(\frac{3\pi}{8}\right)$ is

- (a) $\frac{1}{4}$ (b) $\frac{1}{2\sqrt{2}}$ (c) $\frac{1}{2}$ (d) $\frac{1}{\sqrt{2}}$

(2020 Main, 9 Jan I)

2. The value of $\sin 10^\circ \sin 30^\circ \sin 50^\circ \sin 70^\circ$ is

- (a) $\frac{1}{36}$ (b) $\frac{1}{32}$ (c) $\frac{1}{16}$ (d) $\frac{1}{18}$

(2019 Main, 9 April II)

3. The value of $\cos^2 10^\circ - \cos 10^\circ \cos 50^\circ + \cos^2 50^\circ$ is

- (a) $\frac{3}{2}(1 + \cos 20^\circ)$ (b) $\frac{3}{4} + \cos 20^\circ$
(c) $3/2$ (d) $3/4$

(2019 Main, 9 April I)

4. If the lengths of the sides of a triangle are in AP and the greatest angle is double the smallest, then a ratio of lengths of the sides of this triangle is (2019 Main, 8 April II)

- (a) 3 : 4 : 5 (b) 4 : 5 : 6 (c) 5 : 9 : 13 (d) 5 : 6 : 7

5. If $\cos(\alpha + \beta) = \frac{3}{5}$, $\sin(\alpha - \beta) = \frac{5}{13}$ and $0 < \alpha, \beta < \frac{\pi}{4}$, then $\tan(2\alpha)$ is equal to

- (a) $\frac{63}{52}$ (b) $\frac{63}{16}$ (c) $\frac{21}{16}$ (d) $\frac{33}{52}$

(2019 Main, 8 April I)

6. Let $f_k(x) = \frac{1}{k}(\sin^k x + \cos^k x)$ for $k = 1, 2, 3 \dots$. Then, for all $x \in R$, the value of $f_4(x) - f_6(x)$ is equal to

- (a) $\frac{1}{12}$ (b) $\frac{5}{12}$ (c) $\frac{-1}{12}$ (d) $\frac{1}{4}$

(2019 Main, 11 Jan I)

7. The value of

$$\cos \frac{\pi}{2^2} \cdot \cos \frac{\pi}{2^3} \dots \cos \frac{\pi}{2^{10}} \cdot \sin \frac{\pi}{2^{10}}$$

- is (2019 Main, 10 Jan II)
- (a) $\frac{1}{1024}$ (b) $\frac{1}{2}$ (c) $\frac{1}{512}$ (d) $\frac{1}{256}$

8. For any $\theta \in \left(\frac{\pi}{4}, \frac{\pi}{2}\right)$, the expression

$$3(\sin \theta - \cos \theta)^4 + 6(\sin \theta + \cos \theta)^2 + 4\sin^6 \theta$$

equals (2019 Main, 9 Jan I)

- (a) $13 - 4\cos^4 \theta + 2\sin^2 \theta \cos^2 \theta$
(b) $13 - 4\cos^2 \theta + 6\cos^4 \theta$
(c) $13 - 4\cos^2 \theta + 6\sin^2 \theta \cos^2 \theta$
(d) $13 - 4\cos^6 \theta$

9. The expression $\frac{\tan A}{1 - \cot A} + \frac{\cot A}{1 - \tan A}$ can be written as (2013 Main)

- (a) $\sin A \cos A + 1$ (b) $\sec A \operatorname{cosec} A + 1$
(c) $\tan A + \cot A$ (d) $\sec A + \operatorname{cosec} A$

10. The number of ordered pairs (α, β) , where $\alpha, \beta \in (-\pi, \pi)$ satisfying $\cos(\alpha - \beta) = 1$ and $\cos(\alpha + \beta) = \frac{1}{e}$ is (2005, 1M)

- (a) 0 (b) 1 (c) 2 (d) 4

11. Given both θ and ϕ are acute angles and

$$\sin \theta = \frac{1}{2}, \cos \phi = \frac{1}{3},$$

then the value of $\theta + \phi$ belongs to (2004, 1M)

- (a) $\left[\frac{\pi}{3}, \frac{\pi}{6}\right]$ (b) $\left[\frac{\pi}{2}, \frac{2\pi}{3}\right]$
(c) $\left[\frac{2\pi}{3}, \frac{5\pi}{6}\right]$ (d) $\left[\frac{5\pi}{6}, \pi\right]$

12. Which of the following numbers is rational? (1998, 2M)

- (a) $\sin 15^\circ$ (b) $\cos 15^\circ$
(c) $\sin 15^\circ \cos 15^\circ$ (d) $\sin 15^\circ \cos 75^\circ$

13. $3(\sin x - \cos x)^4 + 6(\sin x + \cos x)^2 + 4(\sin^6 x + \cos^6 x)$ equals (1995, 2M)

- (a) 11 (b) 12 (c) 13 (d) 14

14. The value of the expression $\sqrt{3} \operatorname{cosec} 20^\circ - \sec 20^\circ$ is equal to (1988, 2M)

- (a) 2 (b) $2\sin 20^\circ / \sin 40^\circ$
(c) 4 (d) $4\sin 20^\circ / \sin 40^\circ$

15. The expression $3 \left[\sin^4 \left(\frac{3\pi}{2} - \alpha \right) + \sin^4 (3\pi + \alpha) \right] - 2 \left[\sin^6 \left(\frac{\pi}{2} + \alpha \right) + \sin^6 (5\pi - \alpha) \right]$

is equal to (1986, 2M)

- (a) 0 (b) 1
 (c) 3 (d) $\sin 4\alpha + \cos 6\alpha$

16. $\left(1 + \cos \frac{\pi}{8} \right) \left(1 + \cos \frac{3\pi}{8} \right) \left(1 + \cos \frac{5\pi}{8} \right) \left(1 + \cos \frac{7\pi}{8} \right)$ is equal to (1984, 3M)

- (a) $\frac{1}{2}$ (b) $\cos \frac{\pi}{8}$ (c) $\frac{1}{8}$ (d) $\frac{1 + \sqrt{2}}{2\sqrt{2}}$

17. Given $A = \sin^2 \theta + \cos^4 \theta$, then for all real values of θ (1980, 1M)

- (a) $1 \leq A \leq 2$ (b) $\frac{3}{4} \leq A \leq 1$
 (c) $\frac{13}{16} \leq A \leq 1$ (d) $\frac{3}{4} \leq A \leq \frac{13}{16}$

18. If $\tan \theta = -\frac{4}{3}$, then $\sin \theta$ is (1978, 2M)

- (a) $-\frac{4}{5}$ but not $\frac{4}{5}$ (b) $-\frac{4}{5}$ or $\frac{4}{5}$
 (c) $\frac{4}{5}$ but not $-\frac{4}{5}$ (d) None of the above

Objective Questions II

(One or more than one correct option)

19. Let $f : (-1, 1) \rightarrow R$ be such that $f(\cos 4\theta) = \frac{2}{2 - \sec^2 \theta}$ for

$\theta \in \left(0, \frac{\pi}{4} \right) \cup \left(\frac{\pi}{4}, \frac{\pi}{2} \right)$. Then, the value(s) of $f\left(\frac{1}{3}\right)$ is/are (2012)

- (a) $1 - \sqrt{\frac{3}{2}}$ (b) $1 + \sqrt{\frac{3}{2}}$ (c) $1 - \sqrt{\frac{2}{3}}$ (d) $1 + \sqrt{\frac{2}{3}}$

20. For $0 < \theta < \frac{\pi}{2}$, the solution(s) of $\sum_{m=1}^6 \operatorname{cosec} \left(\theta + \frac{(m-1)\pi}{4} \right) \operatorname{cosec} \left(\theta + \frac{m\pi}{4} \right) = 4\sqrt{2}$ is/are (2009)

- (a) $\frac{\pi}{4}$ (b) $\frac{\pi}{6}$
 (c) $\frac{\pi}{12}$ (d) $\frac{5\pi}{12}$

21. If $\frac{\sin^4 x + \cos^4 x}{2} = \frac{1}{3}$, then (2009)

- (a) $\tan^2 x = \frac{2}{3}$ (b) $\frac{\sin^8 x + \cos^8 x}{8} = \frac{1}{125}$
 (c) $\tan^2 x = \frac{1}{3}$ (d) $\frac{\sin^8 x + \cos^8 x}{8} = \frac{2}{125}$

22. For a positive integer n , let $f_n(\theta) = \left(\tan \frac{\theta}{2} \right) (1 + \sec \theta) (1 + \sec 2\theta) \dots (1 + \sec 2^{n-1} \theta)$, then (1999, 3M)

(a) $f_2 \left(\frac{\pi}{16} \right) = 1$ (b) $f_3 \left(\frac{\pi}{32} \right) = 1$
 (c) $f_4 \left(\frac{\pi}{64} \right) = 1$ (d) $f_5 \left(\frac{\pi}{128} \right) = 1$

Match the Column

Match the conditions/expressions in Column I with values in Column II.

23. $(\sin 3\alpha) / (\cos 2\alpha)$ is (1992, 2M)

Column I	Column II
A. positive	p. $(13\pi/48, 14\pi/48)$
B. negative	q. $(14\pi/48, 18\pi/48)$
	r. $(18\pi/48, 23\pi/48)$
	s. $(0, \pi/2)$

Fill in the Blanks

24. If $k = \sin \left(\frac{\pi}{18} \right) \sin \left(\frac{5\pi}{18} \right) \sin \left(\frac{7\pi}{18} \right)$, then the numerical value of k is (1993, 2M)

25. The value of $\sin \frac{\pi}{14} \cdot \sin \frac{3\pi}{14} \cdot \sin \frac{5\pi}{14} \cdot \sin \frac{7\pi}{14} \cdot \sin \frac{9\pi}{14} \cdot \sin \frac{11\pi}{14} \cdot \sin \frac{13\pi}{14}$ is equal to (1991, 2M)

Analytical & Descriptive Questions

26. Prove that $\tan \alpha + 2 \tan 2\alpha + 4 \tan 4\alpha + 8 \cot 8\alpha = \cot \alpha$ (1988, 2M)

27. Show that $16 \cos \left(\frac{2\pi}{15} \right) \cos \left(\frac{4\pi}{15} \right) \cos \left(\frac{8\pi}{15} \right) \cos \left(\frac{16\pi}{15} \right) = 1$ (1983, 2M)

28. Without using tables, prove that $(\sin 12^\circ) (\sin 48^\circ) (\sin 54^\circ) = \frac{1}{8}$ (1982, 2M)

29. Prove that $\sin^2 \alpha + \sin^2 \beta - \sin^2 \gamma = 2 \sin \alpha \sin \beta \sin \gamma$, where $\alpha + \beta + \gamma = \pi$. (1978, 4M)

Integer & Numerical Answer Type Questions

30. If $\frac{\sqrt{2} \sin \alpha}{\sqrt{1 + \cos 2\alpha}} = \frac{1}{7}$ and $\sqrt{\frac{1 - \cos 2\beta}{2}} = \frac{1}{\sqrt{10}}$, $\alpha, \beta \in \left(0, \frac{\pi}{2} \right)$, then $\tan(\alpha + 2\beta)$ is equal to (2020 Main, 8 Jan II)

31. The number of all possible values of θ , where $0 < \theta < \pi$, for which the system of equations $(y + z) \cos 3\theta = (xyz) \sin 3\theta$

$$x \sin 3\theta = \frac{2 \cos 3\theta}{y} + \frac{2 \sin 3\theta}{z}$$

and $(xyz) \sin 3\theta = (y + 2z) \cos 3\theta + y \sin 3\theta$ have a solution (x_0, y_0, z_0) with $y_0 z_0 \neq 0$, is (2010)

Topic 2 Graph and Conditional Identities

Objective Questions I (Only one correct option)

- If $\alpha + \beta = \frac{\pi}{2}$ and $\beta + \gamma = \alpha$, then $\tan \alpha$ equals (2001, 1M)
 - $2(\tan \beta + \tan \gamma)$
 - $\tan \beta + \tan \gamma$
 - $\tan \beta + 2 \tan \gamma$
 - $2 \tan \beta + \tan \gamma$
- If $\alpha + \beta + \gamma = 2\pi$, then (1979, 2M)
 - $\tan \frac{\alpha}{2} + \tan \frac{\beta}{2} + \tan \frac{\gamma}{2} = \tan \frac{\alpha}{2} \tan \frac{\beta}{2} \tan \frac{\gamma}{2}$
 - $\tan \frac{\alpha}{2} \tan \frac{\beta}{2} + \tan \frac{\beta}{2} \tan \frac{\gamma}{2} + \tan \frac{\gamma}{2} \tan \frac{\alpha}{2} = 1$
 - $\tan \frac{\alpha}{2} + \tan \frac{\beta}{2} + \tan \frac{\gamma}{2} = -\tan \frac{\alpha}{2} \tan \frac{\beta}{2} \tan \frac{\gamma}{2}$
 - None of the above

Fill in the Blank

- Suppose $\sin^3 x \sin 3x = \sum_{m=0}^n C_m \cos nx$ is an identity in x , where C_0, C_1, \dots, C_n are constants and $C_n \neq 0$. Then, the value of n is... (1981, 2M)

Topic 3 Maxima and Minima

Objective Questions I (Only one correct option)

- The maximum value of $3 \cos \theta + 5 \sin \left(\theta - \frac{\pi}{6} \right)$ for any real value of θ is (2019 Main, 12 Jan I)
 - $\frac{\sqrt{79}}{2}$
 - $\sqrt{34}$
 - $\sqrt{31}$
 - $\sqrt{19}$
- Let $\theta \in \left(0, \frac{\pi}{4} \right)$ and $t_1 = (\tan \theta)^{\tan \theta}$, $t_2 = (\tan \theta)^{\cot \theta}$, $t_3 = (\cot \theta)^{\tan \theta}$ and $t_4 = (\cot \theta)^{\cot \theta}$, then (2006, 3M)

True/False

- If $\tan A = (1 - \cos B) / \sin B$, then $\tan 2A = \tan B$. (1993, 1M)

Analytical & Descriptive Questions

- In any triangle, prove that $\cot \frac{A}{2} + \cot \frac{B}{2} + \cot \frac{C}{2} = \cot \frac{A}{2} \cot \frac{B}{2} \cot \frac{C}{2}$ (2000, 3M)
- ABC is a triangle such that $\sin(2A + B) = \sin(C - A) = -\sin(B + 2C) = 1/2$. If A, B and C are in arithmetic progression, determine the values of A, B and C . (1990, 5M)
- Given $\alpha + \beta + \gamma = \pi$, prove that $\sin^2 \alpha + \sin^2 \beta - \sin^2 \gamma = 2 \sin \alpha \sin \beta \cos \gamma$. (1980, 3M)
- If $A + B + C = 180^\circ$, then prove that $\tan A + \tan B + \tan C = \tan A \tan B \tan C$. (1979, 3M)
- If $\cos(\alpha + \beta) = \frac{4}{5}$, $\sin(\alpha - \beta) = \frac{5}{13}$ and α, β lie between 0 and $\pi/4$, find $\tan 2\alpha$. (1979, 4M)

- $t_1 > t_2 > t_3 > t_4$
- $t_4 > t_3 > t_1 > t_2$
- $t_3 > t_1 > t_2 > t_4$
- $t_2 > t_3 > t_1 > t_4$

Fill in the Blank

- If $A > 0, B > 0$ and $A + B = \pi/3$, then the maximum value of $\tan A \tan B$ is (1993)

Analytical & Descriptive Question

- Prove that the values of the function $\frac{\sin x \cos 3x}{\sin 3x \cos x}$ do not lie between $1/3$ and 3 for any real x . (1997, 5M)

Topic 4 Height & Distance

- The angle of elevation of the top of a vertical tower standing on a horizontal plane is observed to be 45° from a point A on the plane. Let B be the point 30 m vertically above the point A . If the angle of elevation of the top of the tower from B be 30° , then the distance (in m) of the foot of the tower from the point A is (2019 Main, 12 April II)
 - $15(3 + \sqrt{3})$
 - $15(5 - \sqrt{3})$
 - $15(3 - \sqrt{3})$
 - $15(1 + \sqrt{3})$
- A 2 m ladder leans against a vertical wall. If the top of the ladder begins to slide down the wall at the rate 25 cm/s, then the rate (in cm/s) at which the bottom of the ladder slides away from the wall on the horizontal

ground when the top of the ladder is 1 m above the ground is (2019 Main, 12 April I)

- $25\sqrt{3}$
- $\frac{25}{\sqrt{3}}$
- $\frac{25}{3}$
- 25

- ABC is a triangular park with $AB = AC = 100$ m. A vertical tower is situated at the mid-point of BC . If the angles of elevation of the top of the tower at A and B are $\cot^{-1}(3\sqrt{2})$ and $\operatorname{cosec}^{-1}(2\sqrt{2})$ respectively, then the height of the tower (in m) is (2019 Main, 10 April I)
 - 25
 - 20
 - $10\sqrt{5}$
 - $\frac{100}{3\sqrt{3}}$

4. Two poles standing on a horizontal ground are of heights 5 m and 10 m, respectively. The line joining their tops makes an angle of 15° with the ground. Then, the distance (in m) between the poles, is
(2019 Main, 9 April II)
- (a) $5(\sqrt{3} + 1)$ (b) $\frac{5}{2}(2 + \sqrt{3})$
(c) $10(\sqrt{3} - 1)$ (d) $5(2 + \sqrt{3})$
5. Two vertical poles of heights, 20 m and 80 m stand apart on a horizontal plane. The height (in m) of the point of intersection of the lines joining the top of each pole to the foot of the other, from this horizontal plane is
(2019 Main, 8 April II)
- (a) 15 (b) 16 (c) 12 (d) 18
6. If the angle of elevation of a cloud from a point P which is 25 m above a lake be 30° and the angle of depression of reflection of the cloud in the lake from P be 60° , then the height of the cloud (in meters) from the surface of the lake is
(2019 Main, 12 Jan II)
- (a) 50 (b) 60 (c) 45 (d) 42
7. Consider a triangular plot ABC with sides $AB = 7$ m, $BC = 5$ m and $CA = 6$ m. A vertical lamp-post at the mid-point D of AC subtends an angle 30° at B . The height (in m) of the lamp-post is
(2019 Main, 10 Jan I)
- (a) $\frac{2}{3}\sqrt{21}$ (b) $2\sqrt{21}$ (c) $7\sqrt{3}$ (d) $\frac{3}{2}\sqrt{21}$
8. PQR is a triangular park with $PQ = PR = 200$ m. A TV tower stands at the mid-point of QR . If the angles of elevation of the top of the tower at P, Q and R are respectively $45^\circ, 30^\circ$ and 30° , then the height of the tower (in m) is
(2018 Main)
- (a) 100 (b) 50
(c) $100\sqrt{3}$ (d) $50\sqrt{2}$
9. Let a vertical tower AB have its end A on the level ground. Let C be the mid-point of AB and P be a point on the ground such that $AP = 2AB$. If $\angle BPC = \beta$, then $\tan \beta$ is equal to
(2017 Main)
- (a) $\frac{6}{7}$ (b) $\frac{1}{4}$
(c) $\frac{2}{9}$ (d) $\frac{4}{9}$
10. A man is walking towards a vertical pillar in a straight path, at a uniform speed. At a certain point A on the path, he observes that the angle of elevation of the top of the pillar is 30° . After walking for 10 min from A in the same direction, at a point B , he observes that the angle of elevation of the top of the pillar is 60° . Then, the time taken (in minutes) by him, from B to reach the pillar, is
(2016 Main)
- (a) 6 (b) 10
(c) 20 (d) 5

Answers

Topic 1

1. (b) 2. (c) 3. (d) 4. (b)
5. (b) 6. (a) 7. (c) 8. (d)
9. (b) 10. (b) 11. (b) 12. (c)
13. (c) 14. (c) 15. (b) 16. (c)
17. (b) 18. (b) 19. (a, b) 20. (c, d)
21. (a, b) 22. (a, b, c, d) 23. $A \rightarrow r; B \rightarrow p$
24. $\frac{1}{8}$ 25. $\frac{1}{64}$ 30. (1) 31. $\theta = \frac{\pi}{12}, \frac{5\pi}{12}, \frac{9\pi}{12}$

Topic 2

1. (c) 2. (a) 3. 6 4. True

6. $A = 45^\circ, B = 60^\circ, C = 75^\circ$

9. $\frac{56}{33}$

Topic 3

1. (d) 2. (b) 3. $\frac{1}{3}$

Topic 4

1. (a) 2. (b) 3. (b) 4. (d)
5. (b) 6. (a) 7. (a) 8. (a)
9. (c) 10. (d)

Hints & Solutions

Topic 1 Based on Trigonometric Formulae

1. Given trigonometric expression

$$\cos^3\left(\frac{\pi}{8}\right) \cos\left(\frac{3\pi}{8}\right) + \sin^3\left(\frac{\pi}{8}\right) \sin\frac{3\pi}{8}$$

$$\cos^3\left(\frac{\pi}{8}\right) \cos\left(\frac{\pi}{2} - \frac{\pi}{8}\right) + \sin^3\left(\frac{\pi}{8}\right) \sin\left(\frac{\pi}{2} - \frac{\pi}{8}\right)$$

$$\left[\because \frac{\pi}{2} - \frac{\pi}{8} = \frac{3\pi}{8} \right]$$

$$= \cos^3\left(\frac{\pi}{8}\right) \sin\left(\frac{\pi}{8}\right) + \sin^3\left(\frac{\pi}{8}\right) \cos\left(\frac{\pi}{8}\right)$$

$$= \sin\left(\frac{\pi}{8}\right) \cos\left(\frac{\pi}{8}\right) \left[\cos^2\left(\frac{\pi}{8}\right) + \sin^2\left(\frac{\pi}{8}\right) \right]$$

$$= \frac{1}{2} \times 2 \sin\left(\frac{\pi}{8}\right) \cos\left(\frac{\pi}{8}\right) = \frac{1}{2} \sin\frac{\pi}{4} = \frac{1}{2\sqrt{2}}$$

Hence, option (b) is correct.

490 Trigonometrical Ratios and Identities

2. We have, $\sin 10^\circ \sin 30^\circ \sin 50^\circ \sin 70^\circ$
 $= \sin(30^\circ) [\sin(10^\circ) \sin(50^\circ) \sin(70^\circ)]$
 $= \frac{1}{2} [\sin(10^\circ) \sin(60^\circ - 10^\circ) \sin(60^\circ + 10^\circ)]$
 $= \frac{1}{2} \left[\frac{1}{4} \sin(3(10^\circ)) \right]$
 $[\because \sin \theta \sin(60^\circ - \theta) \sin(60^\circ + \theta) = \frac{1}{4} \sin 3\theta]$
 $= \frac{1}{8} \sin 30^\circ = \frac{1}{8} \times \frac{1}{2} = \frac{1}{16}$

3. We have, $\cos^2 10^\circ - \cos 10^\circ \cos 50^\circ + \cos^2 50^\circ$
 $= \frac{1}{2} [2 \cos^2 10^\circ - 2 \cos 10^\circ \cos 50^\circ + 2 \cos^2 50^\circ]$
 $= \frac{1}{2} [1 + \cos 20^\circ - (\cos 60^\circ + \cos 40^\circ) + 1 + \cos 100^\circ]$
 $[\because 2 \cos^2 A = 1 + \cos 2A \text{ and}$
 $2 \cos A \cos B = \cos(A+B) + \cos(A-B)]$
 $= \frac{1}{2} \left[2 + \cos 20^\circ + \cos 100^\circ - \frac{1}{2} - \cos 40^\circ \right] \left[\because \cos 60^\circ = \frac{1}{2} \right]$
 $= \frac{1}{2} \left[\frac{3}{2} + (\cos 20^\circ - \cos 40^\circ) + \cos 100^\circ \right]$
 $= \frac{1}{2} \left[\frac{3}{2} - 2 \sin \frac{20^\circ + 40^\circ}{2} \sin \frac{20^\circ - 40^\circ}{2} + \cos 100^\circ \right]$
 $[\because \cos C - \cos D = -2 \sin \frac{C+D}{2} \sin \frac{C-D}{2}]$
 $= \frac{1}{2} \left[\frac{3}{2} - 2 \sin 30^\circ \sin(-10^\circ) + \cos(90^\circ + 10^\circ) \right]$
 $= \frac{1}{2} \left[\frac{3}{2} + \sin 10^\circ - \sin 10^\circ \right] [\because \cos(90^\circ + \theta) = -\sin \theta]$
 $= \frac{1}{2} \times \frac{3}{2} = \frac{3}{4}$

4. Let a, b and c be the lengths of sides of a $\triangle ABC$ such that $a < b < c$.
 Since, sides are in AP.

$$\therefore 2b = a + c \quad \dots(i)$$

Let $\angle A = \theta$

Then, $\angle C = 2\theta$ [according to the question]

$$\text{So, } \angle B = \pi - 3\theta \quad \dots(ii)$$

On applying sine rule in Eq. (i), we get

$$2 \sin B = \sin A + \sin C$$

$$\Rightarrow 2 \sin(\pi - 3\theta) = \sin \theta + \sin 2\theta \quad [\text{from Eq. (ii)}]$$

$$\Rightarrow 2 \sin 3\theta = \sin \theta + \sin 2\theta$$

$$\Rightarrow 2 [3 \sin \theta - 4 \sin^3 \theta] = \sin \theta + 2 \sin \theta \cos \theta$$

$$\Rightarrow 6 - 8 \sin^2 \theta = 1 + 2 \cos \theta \quad [\because \sin \theta \text{ can not be zero}]$$

$$\Rightarrow 6 - 8(1 - \cos^2 \theta) = 1 + 2 \cos \theta$$

$$\Rightarrow 8 \cos^2 \theta - 2 \cos \theta - 3 = 0$$

$$\Rightarrow (2 \cos \theta + 1)(4 \cos \theta - 3) = 0$$

$$\Rightarrow \cos \theta = \frac{3}{4}$$

$$\text{or } \cos \theta = -\frac{1}{2} \text{ (rejected).}$$

Clearly, the ratio of sides is $a : b : c$

$$= \sin \theta : \sin 3\theta : \sin 2\theta$$

$$= \sin \theta : (3 \sin \theta - 4 \sin^3 \theta) : 2 \sin \theta \cos \theta$$

$$= 1 : (3 - 4 \sin^2 \theta) : 2 \cos \theta$$

$$= 1 : (4 \cos^2 \theta - 1) : 2 \cos \theta$$

$$= 1 : \frac{5}{4} : \frac{6}{4} = 4 : 5 : 6$$

5. Given, $\sin(\alpha - \beta) = \frac{5}{13}$

and $\cos(\alpha + \beta) = \frac{3}{5}$, where $\alpha, \beta \in \left(0, \frac{\pi}{4}\right)$

Since, $0 < \alpha < \frac{\pi}{4}$ and $0 < \beta < \frac{\pi}{4}$

$$\therefore 0 < \alpha + \beta < \frac{\pi}{4} + \frac{\pi}{4} = \frac{\pi}{2}$$

$$\Rightarrow 0 < \alpha + \beta < \frac{\pi}{2}$$

Also, $-\frac{\pi}{4} < -\beta < 0$

$$\therefore 0 - \frac{\pi}{4} < \alpha - \beta < \frac{\pi}{4} + 0 \Rightarrow -\frac{\pi}{4} < \alpha - \beta < \frac{\pi}{4}$$

$$\therefore \alpha + \beta \in \left(0, \frac{\pi}{2}\right) \text{ and } \alpha - \beta \in \left(-\frac{\pi}{4}, \frac{\pi}{4}\right)$$

But $\sin(\alpha - \beta) > 0$, therefore $\alpha - \beta \in \left(0, \frac{\pi}{4}\right)$.

Now, $\sin(\alpha - \beta) = \frac{5}{13}$

$$\Rightarrow \tan(\alpha - \beta) = \frac{5}{12} \quad \dots(i)$$

and $\cos(\alpha + \beta) = \frac{3}{5}$

$$\Rightarrow \tan(\alpha + \beta) = \frac{4}{3} \quad \dots(ii)$$

Now, $\tan(2\alpha) = \tan[(\alpha + \beta) + (\alpha - \beta)]$

$$= \frac{\tan(\alpha + \beta) + \tan(\alpha - \beta)}{1 - \tan(\alpha + \beta) \tan(\alpha - \beta)} = \frac{\frac{4}{3} + \frac{5}{12}}{1 - \frac{4}{3} \times \frac{5}{12}}$$

[from Eqs. (i) and (ii)]

$$= \frac{48 + 15}{36 - 20} = \frac{63}{16}$$

6. We have,

$$f_k(x) = \frac{1}{k} (\sin^k x + \cos^k x), k = 1, 2, 3, \dots$$

$$\therefore f_4(x) = \frac{1}{4} (\sin^4 x + \cos^4 x)$$

$$= \frac{1}{4} ((\sin^2 x + \cos^2 x)^2 - 2 \sin^2 x \cos^2 x)$$

$$\begin{aligned}
 &= \frac{1}{4} \left(1 - \frac{1}{2} (\sin 2x)^2 \right) = \frac{1}{4} - \frac{1}{8} \sin^2 2x \\
 \text{and } f_6(x) &= \frac{1}{6} (\sin^6 x + \cos^6 x) \\
 &= \frac{1}{6} \{ (\sin^2 x + \cos^2 x)^3 - 3 \sin^2 x \cos^2 x \\
 &\quad (\sin^2 x + \cos^2 x) \} \\
 &= \frac{1}{6} \left\{ 1 - \frac{3}{4} (2 \sin x \cos x)^2 \right\} = \frac{1}{6} - \frac{1}{8} \sin^2 2x
 \end{aligned}$$

$$\text{Now, } f_4(x) - f_6(x) = \frac{1}{4} - \frac{1}{6} = \frac{3-2}{12} = \frac{1}{12}$$

7. We know that,

$$\begin{aligned}
 \cos \alpha \cdot \cos (2\alpha) \cos (2^2\alpha) \dots \cos (2^{n-1}\alpha) &= \frac{\sin (2^n\alpha)}{2^n \sin \alpha} \\
 \therefore \cos \frac{\pi}{2^2} \cdot \cos \frac{\pi}{2^3} \dots \cos \frac{\pi}{2^{10}} \cdot \sin \frac{\pi}{2^{10}} \\
 &= \left\{ \frac{\sin \left(\frac{\pi}{2^{10}} 2^9 \right)}{2^9 \sin \left(\frac{\pi}{2^{10}} \right)} \right\} \sin \frac{\pi}{2^{10}} \quad [\because \text{here, } \alpha = \frac{\pi}{2^{10}} \text{ and } n = 9] \\
 &= \frac{1}{2^9} \sin \left(\frac{\pi}{2} \right) = \frac{1}{2^9} = \frac{1}{512}
 \end{aligned}$$

8. Given expression

$$\begin{aligned}
 &= 3(\sin \theta - \cos \theta)^4 + 6(\sin \theta + \cos \theta)^2 + 4 \sin^6 \theta \\
 &= 3((\sin \theta - \cos \theta)^2)^2 + 6(\sin \theta + \cos \theta)^2 + 4(\sin^2 \theta)^3 \\
 &= 3(1 - \sin 2\theta)^2 + 6(1 + \sin 2\theta) + 4(1 - \cos^2 \theta)^3 \\
 &\quad [\because 1 + \sin 2\theta = (\cos \theta + \sin \theta)^2 \\
 &\quad \text{and } 1 - \sin 2\theta = (\cos \theta - \sin \theta)^2] \\
 &= 3(1^2 + \sin^2 2\theta - 2 \sin 2\theta) + 6(1 + \sin 2\theta) \\
 &\quad + 4(1 - \cos^6 \theta - 3 \cos^2 \theta + 3 \cos^4 \theta) \\
 &\quad [\because (a-b)^2 = a^2 + b^2 - 2ab \\
 &\quad \text{and } (a-b)^3 = a^3 - b^3 - 3a^2b + 3ab^2] \\
 &= 3 + 3 \sin^2 2\theta - 6 \sin 2\theta + 6 + 6 \sin 2\theta + 4 \\
 &\quad - 4 \cos^6 \theta - 12 \cos^2 \theta + 12 \cos^4 \theta \\
 &= 13 + 3 \sin^2 2\theta - 4 \cos^6 \theta - 12 \cos^2 \theta + 12 \cos^4 \theta \\
 &= 13 + 3(2 \sin \theta \cos \theta)^2 - 4 \cos^6 \theta - 12 \cos^2 \theta (1 - \cos^2 \theta) \\
 &= 13 + 12 \sin^2 \theta \cos^2 \theta - 4 \cos^6 \theta - 12 \cos^2 \theta \sin^2 \theta \\
 &= 13 - 4 \cos^6 \theta
 \end{aligned}$$

9. Given expression is

$$\begin{aligned}
 &\frac{\tan A}{1 - \cot A} + \frac{\cot A}{1 - \tan A} \\
 &= \frac{\sin A}{\cos A} \times \frac{\sin A}{\sin A - \cos A} + \frac{\cos A}{\sin A} \times \frac{\cos A}{\cos A - \sin A} \\
 &= \frac{1}{\sin A - \cos A} \left\{ \frac{\sin^3 A - \cos^3 A}{\cos A \sin A} \right\} \\
 &= \frac{\sin^2 A + \sin A \cos A + \cos^2 A}{\sin A \cos A} \\
 &= \frac{1 + \sin A \cos A}{\sin A \cos A} = 1 + \sec A \operatorname{cosec} A
 \end{aligned}$$

$$\begin{aligned}
 \text{10. Since, } &\cos (\alpha - \beta) = 1 \\
 \Rightarrow &\alpha - \beta = 2n\pi \\
 \text{But } &-2\pi < \alpha - \beta < 2\pi \quad [\text{as } \alpha, \beta \in (-\pi, \pi)] \\
 \therefore &\alpha - \beta = 0 \quad \dots(i) \\
 \text{Given, } &\cos (\alpha + \beta) = \frac{1}{e} \\
 \Rightarrow \cos 2\alpha &= \frac{1}{e} < 1, \text{ which is true for four values of } \alpha. \\
 &[\text{as } -2\pi < 2\alpha < 2\pi]
 \end{aligned}$$

$$\begin{aligned}
 \text{11. Since, } \sin \theta &= \frac{1}{2} \\
 \text{and } \cos \phi &= \frac{1}{3} \Rightarrow \theta = \frac{\pi}{6} \\
 \text{and } 0 < \left(\cos \phi = \frac{1}{3} \right) < \frac{1}{2} & \quad \left[\text{as } 0 < \frac{1}{3} < \frac{1}{2} \right] \\
 \Rightarrow \theta = \frac{\pi}{6} \text{ and } \cos^{-1}(0) > \phi > \cos^{-1} \left(\frac{1}{2} \right) \\
 \left[\text{the sign changed as } \cos x \text{ is decreasing between } \left(0, \frac{\pi}{2} \right) \right] \\
 \Rightarrow \theta = \frac{\pi}{6} \text{ and } \frac{\pi}{3} < \phi < \frac{\pi}{2} \Rightarrow \frac{\pi}{2} < \theta + \phi < \frac{2\pi}{3} \\
 \therefore \theta \in \left(\frac{\pi}{2}, \frac{2\pi}{3} \right)
 \end{aligned}$$

$$\begin{aligned}
 \text{12. Since, } \sin 15^\circ &= \frac{1}{2} \sqrt{2 - \sqrt{3}} \text{ and } \cos 15^\circ = \frac{1}{2} \sqrt{2 + \sqrt{3}} \\
 \text{and } \sin 15^\circ \cos 75^\circ &= \sin 15^\circ \cdot \sin 15^\circ = \frac{1}{4} (2 - \sqrt{3})
 \end{aligned}$$

Therefore, all these values are irrational and

$$\begin{aligned}
 \sin 15^\circ \cos 15^\circ &= \frac{1}{2} \cdot 2 \sin 15^\circ \cos 15^\circ \\
 &= \frac{1}{2} \cdot \sin 30^\circ = \frac{1}{4}, \text{ which is rational.}
 \end{aligned}$$

$$\begin{aligned}
 \text{13. Given expression} &= \\
 &3(\sin x - \cos x)^4 + 6(\sin x + \cos x)^2 + 4(\sin^6 x + \cos^6 x) \\
 &= 3(1 - \sin 2x)^2 + 6(1 + \sin 2x) + 4\{(\sin^2 x + \cos^2 x)^3 \\
 &\quad - 3 \sin^2 x \cos^2 x (\sin^2 x + \cos^2 x)\} \\
 &= 3(1 - 2 \sin 2x + \sin^2 2x) + 6 + 6 \sin 2x \\
 &\quad + 4(1 - 3 \sin^2 x \cos^2 x) \\
 &= 3(1 - 2 \sin 2x + \sin^2 2x + 2 + 2 \sin 2x) + 4 \left(1 - \frac{3}{4} \sin^2 2x \right) \\
 &= 13 + 3 \sin^2 2x - 3 \sin^2 2x = 13
 \end{aligned}$$

14. Given expression =

$$\begin{aligned}
 \sqrt{3} \operatorname{cosec} 20^\circ - \sec 20^\circ &= \tan 60^\circ \operatorname{cosec} 20^\circ - \sec 20^\circ \\
 &= \frac{\sin 60^\circ \cos 20^\circ - \cos 60^\circ \cdot \sin 20^\circ}{\cos 60^\circ \cdot \sin 20^\circ \cdot \cos 20^\circ} \\
 &= \frac{\sin (60^\circ - 20^\circ)}{\cos 60^\circ \cdot \sin 20^\circ \cdot \cos 20^\circ} = \frac{\sin 40^\circ}{\frac{1}{2} \cdot \sin 20^\circ \cos 20^\circ} \\
 &= \frac{2 \sin 20^\circ \cos 20^\circ}{\frac{1}{2} \sin 20^\circ \cos 20^\circ} = 4
 \end{aligned}$$

492 Trigonometrical Ratios and Identities

15. Given expression =

$$\begin{aligned} & 3 \left[\sin^4 \left(\frac{3\pi}{2} - \alpha \right) + \sin^4 (3\pi + \alpha) \right] - 2 \left[\sin^6 \left(\frac{\pi}{2} + \alpha \right) \right. \\ & \qquad \qquad \qquad \left. + \sin^6 (5\pi - \alpha) \right] \\ & = 3 (\cos^4 \alpha + \sin^4 \alpha) - 2 (\cos^6 \alpha + \sin^6 \alpha) \\ & = 3 (1 - 2 \sin^2 \alpha \cos^2 \alpha) - 2 (1 - 3 \sin^2 \alpha \cos^2 \alpha) \\ & = 3 - 6 \sin^2 \alpha \cos^2 \alpha - 2 + 6 \sin^2 \alpha \cos^2 \alpha = 1 \end{aligned}$$

16. Given expression =

$$\begin{aligned} & \left(1 + \cos \frac{\pi}{8} \right) \left(1 + \cos \frac{3\pi}{8} \right) \left(1 + \cos \frac{5\pi}{8} \right) \left(1 + \cos \frac{7\pi}{8} \right) \\ & = \left(1 + \cos \frac{\pi}{8} \right) \left(1 + \cos \frac{3\pi}{8} \right) \left(1 - \cos \frac{3\pi}{8} \right) \left(1 - \cos \frac{\pi}{8} \right) \\ & = \left(1 - \cos^2 \frac{\pi}{8} \right) \left(1 - \cos^2 \frac{3\pi}{8} \right) \\ & = \frac{1}{4} \left(2 - 1 - \cos \frac{\pi}{4} \right) \left(2 - 1 - \cos 3 \frac{\pi}{4} \right) \\ & = \frac{1}{4} \left(1 - \cos \frac{\pi}{4} \right) \left(1 - \cos 3 \frac{\pi}{4} \right) \\ & = \frac{1}{4} \left(1 - \frac{1}{\sqrt{2}} \right) \left(1 + \frac{1}{\sqrt{2}} \right) = \frac{1}{4} \left(1 - \frac{1}{2} \right) = \frac{1}{8} \end{aligned}$$

17. Given, $A = \sin^2 \theta + (1 - \sin^2 \theta)^2$

$$\begin{aligned} \Rightarrow & A = \sin^4 \theta - \sin^2 \theta + 1 \\ \Rightarrow & A = \left(\sin^2 \theta - \frac{1}{2} \right)^2 + \frac{3}{4} \\ \Rightarrow & 0 \leq \left(\sin^2 \theta - \frac{1}{2} \right)^2 \leq \frac{1}{4} \quad [\because 0 \leq \sin^2 \theta \leq 1] \\ \therefore & \frac{3}{4} \leq A \leq 1 \end{aligned}$$

18. Since, $\tan \theta < 0$.

\therefore Angle θ is either in the second or fourth quadrant.

Then, $\sin \theta > 0$ or < 0

$\therefore \sin \theta$ may be $\frac{4}{5}$ or $-\frac{4}{5}$

19. $f(\cos 4\theta) = \frac{2}{2 - \sec^2 \theta}$... (i)

$$\begin{aligned} \text{At } \cos 4\theta &= \frac{1}{3} \\ \Rightarrow 2 \cos^2 2\theta - 1 &= \frac{1}{3} \\ \Rightarrow \cos^2 2\theta &= \frac{2}{3} \Rightarrow \cos 2\theta = \pm \sqrt{\frac{2}{3}} \quad \dots \text{(ii)} \end{aligned}$$

$$\begin{aligned} \therefore f(\cos 4\theta) &= \frac{2 \cdot \cos^2 \theta}{2 \cos^2 \theta - 1} \\ &= \frac{1 + \cos 2\theta}{\cos 2\theta} \\ \Rightarrow f\left(\frac{1}{3}\right) &= 1 \pm \sqrt{\frac{3}{2}} \quad [\text{from Eq. (ii)}] \end{aligned}$$

20. For $0 < \theta < \frac{\pi}{2}$

$$\begin{aligned} & \sum_{m=1}^6 \operatorname{cosec} \left(\theta + \frac{(m-1)\pi}{4} \right) \operatorname{cosec} \left(\theta + \frac{m\pi}{4} \right) = 4\sqrt{2} \\ \Rightarrow & \sum_{m=1}^6 \frac{1}{\sin \left(\theta + \frac{(m-1)\pi}{4} \right) \sin \left(\theta + \frac{m\pi}{4} \right)} = 4\sqrt{2} \\ \Rightarrow & \sum_{m=1}^6 \frac{\sin \left[\theta + \frac{m\pi}{4} - \left(\theta + \frac{(m-1)\pi}{4} \right) \right]}{\sin \frac{\pi}{4} \left\{ \sin \left(\theta + \frac{(m-1)\pi}{4} \right) \sin \left(\theta + \frac{m\pi}{4} \right) \right\}} = 4\sqrt{2} \\ \Rightarrow & \sum_{m=1}^6 \frac{\cot \left(\theta + \frac{(m-1)\pi}{4} \right) - \cot \left(\theta + \frac{m\pi}{4} \right)}{1/\sqrt{2}} = 4\sqrt{2} \\ \Rightarrow & \sum_{m=1}^6 \left[\cot \left(\theta + \frac{(m-1)\pi}{4} \right) - \cot \left(\theta + \frac{m\pi}{4} \right) \right] = 4 \\ \Rightarrow & \cot \theta - \cot \left(\theta + \frac{\pi}{4} \right) + \cot \left(\theta + \frac{\pi}{4} \right) - \cot \left(\theta + \frac{2\pi}{4} \right) \\ & \quad + \dots + \cot \left(\theta + \frac{5\pi}{4} \right) - \cot \left(\theta + \frac{6\pi}{4} \right) = 4 \\ \Rightarrow & \cot \theta - \cot \left(\frac{3\pi}{2} + \theta \right) = 4 \\ \Rightarrow & \cot \theta + \tan \theta = 4 \\ \Rightarrow & \tan^2 \theta - 4 \tan \theta + 1 = 0 \\ \Rightarrow & (\tan \theta - 2)^2 - 3 = 0 \\ \Rightarrow & (\tan \theta - 2 + \sqrt{3})(\tan \theta - 2 - \sqrt{3}) = 0 \\ \Rightarrow & \tan \theta = 2 - \sqrt{3} \text{ or } \tan \theta = 2 + \sqrt{3} \\ \Rightarrow & \theta = \frac{\pi}{12}; \theta = \frac{5\pi}{12} \quad \left[\because \theta \in \left(0, \frac{\pi}{2} \right) \right] \end{aligned}$$

21. $\frac{\sin^4 x}{2} + \frac{\cos^4 x}{3} = \frac{1}{5} \Rightarrow \frac{\sin^4 x}{2} + \frac{(1 - \sin^2 x)^2}{3} = \frac{1}{5}$

$$\begin{aligned} \Rightarrow & \frac{\sin^4 x}{2} + \frac{1 + \sin^4 x - 2 \sin^2 x}{3} = \frac{1}{5} \\ \Rightarrow & 5 \sin^4 x - 4 \sin^2 x + 2 = \frac{6}{5} \\ \Rightarrow & 25 \sin^4 x - 20 \sin^2 x + 4 = 0 \\ \Rightarrow & (5 \sin^2 x - 2)^2 = 0 \\ \Rightarrow & \sin^2 x = \frac{2}{5} \\ & \cos^2 x = \frac{3}{5}, \tan^2 x = \frac{2}{3} \\ \therefore & \frac{\sin^8 x}{8} + \frac{\cos^8 x}{27} = \frac{1}{125} \end{aligned}$$

22. **NOTE** Multiplicative loop is very important approach in IIT Mathematics.

$$\begin{aligned} \left(\tan \frac{\theta}{2} \right) (1 + \sec \theta) &= \frac{\sin \theta / 2}{\cos \theta / 2} \left[1 + \frac{1}{\cos \theta} \right] \\ &= \frac{(\sin \theta / 2) 2 \cos^2 \theta / 2}{(\cos \theta / 2) \cos \theta} \\ &= \frac{(2 \sin \theta / 2) \cos \theta / 2}{\cos \theta} = \frac{\sin \theta}{\cos \theta} = \tan \theta \end{aligned}$$

$$\begin{aligned} \therefore f_n(\theta) &= (\tan \theta/2)(1 + \sec \theta) \\ (1 + \sec 2\theta)(1 + \sec 2^2\theta)\dots(1 + \sec 2^n\theta) \\ &= (\tan \theta)(1 + \sec 2\theta)(1 + \sec 2^2\theta)\dots(1 + \sec 2^n\theta) \\ &= \tan 2\theta \cdot (1 + \sec 2^2\theta)\dots(1 + \sec 2^n\theta) \\ &= \tan(2^n\theta) \end{aligned}$$

Now, $f_2\left(\frac{\pi}{16}\right) = \tan\left(2^2 \cdot \frac{\pi}{16}\right) = \tan\left(\frac{\pi}{4}\right) = 1$

Therefore, (a) is the answer.

$$f_3\left(\frac{\pi}{32}\right) = \tan\left(2^3 \cdot \frac{\pi}{32}\right) = \tan\left(\frac{\pi}{4}\right) = 1$$

Therefore, (b) is the answer.

$$f_4\left(\frac{\pi}{64}\right) = \tan\left(2^4 \cdot \frac{\pi}{64}\right) = \tan\left(\frac{\pi}{4}\right) = 1$$

Therefore, (c) is the answer.

$$f_5\left(\frac{\pi}{128}\right) = \tan\left(2^5 \cdot \frac{\pi}{128}\right) = \tan\left(\frac{\pi}{4}\right) = 1$$

Therefore, (d) is the answer.

23. In the interval $\left(\frac{13\pi}{48}, \frac{14\pi}{48}\right)$, $\cos 2\alpha < 0$ and $\sin 3\alpha > 0$.

$$\Rightarrow \frac{\sin 3\alpha}{\cos 2\alpha} \text{ is negative, therefore } B \rightarrow p.$$

Again, in the interval $\left(\frac{18\pi}{48}, \frac{23\pi}{48}\right)$, both $\sin 3\alpha$ and $\cos 2\alpha$ are negative, so $\frac{\sin 3\alpha}{\cos 2\alpha}$ is positive, therefore $A \rightarrow r$.

24. Using the relation,

$$\sin \theta \sin\left(\frac{\pi}{3} - \theta\right) \sin\left(\frac{\pi}{3} + \theta\right) = \frac{\sin 3\theta}{4}$$

Taking $\theta = \frac{\pi}{18}$, we get

$$\sin \frac{\pi}{18} \cdot \sin \frac{5\pi}{18} \cdot \sin \frac{7\pi}{18} = \frac{\sin \frac{\pi}{6}}{4} = \frac{1}{8}$$

Alternative Method

$$\begin{aligned} \text{Given, } k &= \sin 10^\circ \cdot \sin 50^\circ \cdot \sin 70^\circ \\ &= \cos 80^\circ \cdot \cos 40^\circ \cdot \cos 20^\circ \\ &= \cos A \cdot \cos 2A \cdot \cos 2^2A = \frac{\sin 2^3 A}{2^3 \sin A} \end{aligned}$$

where, $A = 20^\circ$

$$= \frac{\sin 160^\circ}{8 \sin 20^\circ} = \frac{\sin (180^\circ - 20^\circ)}{8 \sin 20^\circ} = \frac{\sin 20^\circ}{8 \sin 20^\circ} = \frac{1}{8}$$

25. $\sin \frac{\pi}{14} \cdot \sin \frac{3\pi}{14} \cdot \sin \frac{5\pi}{14} \cdot \sin \frac{7\pi}{14} \cdot \sin \frac{9\pi}{14} \cdot \sin \frac{11\pi}{14} \cdot \sin \frac{13\pi}{14}$
 $= \sin \frac{\pi}{14} \cdot \sin \frac{3\pi}{14} \cdot \sin \frac{5\pi}{14} \cdot \sin\left(\pi - \frac{5\pi}{14}\right)$
 $\quad \cdot \sin\left(\pi - \frac{3\pi}{14}\right) \cdot \sin\left(\pi - \frac{\pi}{14}\right)$
 $= \sin^2 \frac{\pi}{14} \cdot \sin^2 \frac{3\pi}{14} \cdot \sin^2 \frac{5\pi}{14} = \left(\sin \frac{\pi}{14} \cdot \sin \frac{3\pi}{14} \cdot \sin \frac{5\pi}{14}\right)^2$

$$\begin{aligned} &= \left(\cos\left(\frac{\pi}{2} - \frac{\pi}{14}\right) \cdot \cos\left(\frac{\pi}{2} - \frac{3\pi}{14}\right) \cdot \cos\left(\frac{\pi}{2} - \frac{5\pi}{14}\right)\right)^2 \\ &= \left(\cos \frac{3\pi}{7} \cdot \cos \frac{2\pi}{7} \cdot \cos \frac{\pi}{7}\right)^2 \\ &= \left(-\cos \frac{\pi}{7} \cdot \cos \frac{2\pi}{7} \cdot \cos \frac{4\pi}{7}\right)^2 \\ &= \left(-\frac{\sin 2^3 \pi / 7}{2^3 \cdot \sin \pi / 7}\right)^2 \\ &= \left(-\frac{1}{8} \cdot \frac{\sin 8\pi / 7}{\sin \pi / 7}\right)^2 \quad \left[\because \sin \frac{8\pi}{7} = \sin\left(\pi + \frac{\pi}{7}\right) = -\sin \frac{\pi}{7}\right] \\ &= 1/64 \end{aligned}$$

26. We know that,

$$\cot \theta - \tan \theta = \frac{1 - \tan^2 \theta}{\tan \theta} = 2 \left(\frac{1 - \tan^2 \theta}{2 \tan \theta}\right) = 2 \cot 2\theta \quad \dots(i)$$

$$\begin{aligned} \text{LHS} &= \tan \alpha + 2 \tan 2\alpha + 4 \tan 4\alpha + 8 \cot 8\alpha \\ &= -(\cot \alpha - \tan \alpha - 2 \tan 2\alpha - 4 \tan 4\alpha) \\ &\quad + 8 \cot 8\alpha + \cot \alpha \\ &= -(2 \cot 2\alpha - 2 \tan 2\alpha - 4 \tan 4\alpha) \\ &\quad + 8 \cot 8\alpha + \cot \alpha \\ &= -(2(\cot 2\alpha - \tan 2\alpha) - 4 \tan 4\alpha) \\ &\quad + 8 \cot 8\alpha + \cot \alpha \\ &= -(2(2 \cot 4\alpha) - 4 \tan 4\alpha) + 8 \cot 8\alpha + \cot \alpha \\ &\quad \text{[from Eq. (i)]} \\ &= -4(\cot 4\alpha - \tan 4\alpha) + 8 \cot 8\alpha + \cot \alpha \\ &= -8 \cot 8\alpha + 8 \cot 8\alpha + \cot \alpha \quad \text{[from Eq. (i)]} \\ &= \cot \alpha = \text{RHS} \end{aligned}$$

27. $16 \left(\cos \frac{2\pi}{15} \cdot \cos \frac{4\pi}{15} \cdot \cos \frac{8\pi}{15} \cdot \cos \frac{16\pi}{15}\right)$
 $= 16(\cos A \cdot \cos 2A \cdot \cos 2^2 A \cdot \cos 2^3 A)$
 $\quad \left[\text{where, } A = \frac{2\pi}{15}\right]$

$$= 16 \left(\frac{\sin 2^4 A}{2^4 \sin A}\right) = \frac{\sin 2^4 \left(\frac{2\pi}{15}\right)}{\sin \left(\frac{2\pi}{15}\right)}$$

$$= \frac{\sin \left(\frac{32\pi}{15}\right)}{\sin \left(\frac{2\pi}{15}\right)} = \frac{\sin \left(2\pi + \frac{2\pi}{15}\right)}{\sin \left(\frac{2\pi}{15}\right)}$$

$$= \frac{\sin \left(\frac{2\pi}{15}\right)}{\sin \left(\frac{2\pi}{15}\right)} = 1$$

28. $\sin 12^\circ \sin 48^\circ \sin 54^\circ = \frac{1}{2} (2 \sin 12^\circ \sin 48^\circ) \sin 54^\circ$
 $= \frac{1}{2} [\cos (36^\circ) - \cos (60^\circ)] \sin 54^\circ$

494 Trigonometrical Ratios and Identities

$$\begin{aligned}
 &= \frac{1}{2} \left(\cos 36^\circ - \frac{1}{2} \right) \sin 54^\circ \\
 &= \frac{1}{4} (2 \cos 36^\circ \sin 54^\circ - \sin 54^\circ) \\
 &= \frac{1}{4} (\sin 90^\circ + \sin 18^\circ - \sin 54^\circ) \\
 &= \frac{1}{4} \left(1 + \frac{\sqrt{5}-1}{4} - \frac{\sqrt{5}+1}{4} \right) \\
 &= \frac{1}{4} \left(1 + \frac{\sqrt{5}-1-\sqrt{5}-1}{4} \right) \\
 &= \frac{1}{4} \left(1 - \frac{1}{2} \right) = \frac{1}{8}
 \end{aligned}$$

29. $\text{LHS} = \sin^2 \alpha + \sin^2 \beta - \sin^2 \gamma$

$$\begin{aligned}
 &= \sin^2 \alpha + (\sin^2 \beta - \sin^2 \gamma) \\
 &= \sin^2 \alpha + \sin(\beta + \gamma) \sin(\beta - \gamma) \\
 &= \sin^2 \alpha + \sin(\pi - \alpha) \sin(\beta - \gamma) \quad [\because \alpha + \beta + \gamma = \pi] \\
 &= \sin^2 \alpha + \sin \alpha \sin(\beta - \gamma) \\
 &= \sin \alpha [\sin \alpha + \sin(\beta - \gamma)] \\
 &= \sin \alpha [\sin(\pi - (\beta + \gamma)) + \sin(\beta - \gamma)] \\
 &= \sin \alpha [\sin(\beta + \gamma) + \sin(\beta - \gamma)] \\
 &= \sin \alpha [2 \sin \beta \cos \gamma] \\
 &= 2 \sin \alpha \sin \beta \cos \gamma = \text{RHS}
 \end{aligned}$$

30. It is given that, for $\alpha, \beta \in \left(0, \frac{\pi}{2}\right)$

$$\begin{aligned}
 \Rightarrow \quad & \frac{\sqrt{2} \sin \alpha}{\sqrt{1 + \cos 2\alpha}} = \frac{1}{7} \\
 \Rightarrow \quad & \frac{\sqrt{2} \sin \alpha}{\sqrt{2} |\cos \alpha|} = \frac{1}{7} \\
 \Rightarrow \quad & \tan \alpha = \frac{1}{7} \quad \because \alpha \in \left(0, \frac{\pi}{2}\right) \dots \text{(i)}
 \end{aligned}$$

and $\sqrt{\frac{1 - \cos 2\beta}{2}} = \frac{1}{\sqrt{10}}$

$$\begin{aligned}
 \Rightarrow \quad & |\sin \beta| = \frac{1}{\sqrt{10}} \\
 \Rightarrow \quad & \sin \beta = \frac{1}{\sqrt{10}} \quad \because \beta \in \left(0, \frac{\pi}{2}\right) \\
 \therefore \quad & \tan \beta = \frac{1}{3} \quad \dots \text{(ii)} \\
 \therefore \quad & \tan 2\beta = \frac{2 \tan \beta}{1 - \tan^2 \beta} \\
 &= \frac{2}{1 - \frac{1}{9}} = \frac{6}{8} = \frac{3}{4}
 \end{aligned}$$

Now, $\tan(\alpha + 2\beta) = \frac{\tan \alpha + \tan 2\beta}{1 - \tan \alpha \tan 2\beta}$

$$\begin{aligned}
 &= \frac{\frac{1}{7} + \frac{3}{4}}{1 - \left(\frac{1}{7} \times \frac{3}{4}\right)} = \frac{4 + 21}{28 - 3} = \frac{25}{25} = 1
 \end{aligned}$$

Hence, answer is 1.

31. Given equations can be written as

$$x \sin 3\theta - \frac{\cos 3\theta}{y} - \frac{\cos 3\theta}{z} = 0 \quad \dots \text{(i)}$$

$$x \sin 3\theta - \frac{2 \cos 3\theta}{y} - \frac{2 \sin 3\theta}{z} = 0 \quad \dots \text{(ii)}$$

and $x \sin 3\theta - \frac{2}{y} \cos 3\theta - \frac{1}{z} (\cos 3\theta + \sin 3\theta) = 0 \quad \dots \text{(iii)}$

Eqs. (ii) and (iii), implies

$$2 \sin 3\theta = \cos 3\theta + \sin 3\theta$$

$$\Rightarrow \sin 3\theta = \cos 3\theta$$

$$\therefore \tan 3\theta = 1$$

$$\Rightarrow 3\theta = \frac{\pi}{4}, \frac{5\pi}{4}, \frac{9\pi}{4} \text{ or } \theta = \frac{\pi}{12}, \frac{5\pi}{12}, \frac{9\pi}{12}$$

Topic 2 Graph and Conditional Identities

1. Given, $\alpha + \beta = \pi/2$

$$\begin{aligned}
 \Rightarrow \quad & \alpha = (\pi/2) - \beta \\
 \Rightarrow \quad & \tan \alpha = \tan(\pi/2 - \beta) \\
 \Rightarrow \quad & \tan \alpha = \cot \beta \\
 \Rightarrow \quad & \tan \alpha \tan \beta = 1
 \end{aligned}$$

Again, $\beta + \gamma = \alpha$ [given]

$$\Rightarrow \gamma = (\alpha - \beta)$$

$$\Rightarrow \tan \gamma = \tan(\alpha - \beta)$$

$$\Rightarrow \tan \gamma = \frac{\tan \alpha - \tan \beta}{1 + \tan \alpha \tan \beta}$$

$$\Rightarrow \tan \gamma = \frac{\tan \alpha - \tan \beta}{1 + 1}$$

$$\therefore 2 \tan \gamma = \tan \alpha - \tan \beta$$

$$\Rightarrow \tan \alpha = \tan \beta + 2 \tan \gamma$$

2. Since, $\frac{\alpha}{2} + \frac{\beta}{2} = \left(\pi - \frac{\gamma}{2}\right)$

$$\therefore \tan\left(\frac{\alpha}{2} + \frac{\beta}{2}\right) = \tan\left(\pi - \frac{\gamma}{2}\right)$$

$$\Rightarrow \frac{\tan \frac{\alpha}{2} + \tan \frac{\beta}{2}}{1 - \tan \frac{\alpha}{2} \tan \frac{\beta}{2}} = -\tan \frac{\gamma}{2}$$

$$\Rightarrow \tan \frac{\alpha}{2} + \tan \frac{\beta}{2} + \tan \frac{\gamma}{2} = \tan \frac{\alpha}{2} \tan \frac{\beta}{2} \tan \frac{\gamma}{2}$$

3. Given, $\sin^3 x \sin 3x = \sum_{m=0}^n C_m \cos nx$ is an identity in x ,

where, C_0, C_1, \dots, C_n are constants.

$$\sin^3 x \sin 3x = \frac{1}{4} \{3 \sin x - \sin 3x\} \cdot \sin 3x$$

$$= \frac{1}{4} \left(\frac{3}{2} \cdot 2 \sin x \cdot \sin 3x - \sin^2 3x \right)$$

$$= \frac{1}{4} \left\{ \frac{3}{2} (\cos 2x - \cos x) - \frac{1}{2} (1 - \cos 6x) \right\}$$

$$= \frac{1}{8} (\cos 6x + 3 \cos 2x - 3 \cos x - 1)$$

\therefore On comparing both sides, we get $n = 6$

4. Since, $\tan A = \frac{1 - \cos B}{\sin B} = \frac{2 \sin^2 \frac{B}{2}}{2 \sin \frac{B}{2} \cos \frac{B}{2}}$
 $\tan A = \tan B/2$
 $\Rightarrow \tan 2A = \tan B$
 Hence, it is a true statement.
5. Since, $A + B + C = \pi$
 $\Rightarrow \frac{A}{2} + \frac{B}{2} = \frac{\pi}{2} - \frac{C}{2}$
 $\Rightarrow \cot\left(\frac{A}{2} + \frac{B}{2}\right) = \cot\left(\frac{\pi}{2} - \frac{C}{2}\right)$
 $\Rightarrow \frac{\cot \frac{A}{2} \cdot \cot \frac{B}{2} - 1}{\cot \frac{B}{2} + \cot \frac{A}{2}} = \tan \frac{C}{2}$
 $\Rightarrow \cot \frac{A}{2} \cdot \cot \frac{B}{2} \cdot \cot \frac{C}{2} - \cot \frac{C}{2} = \cot \frac{A}{2} + \cot \frac{B}{2}$
 $\Rightarrow \cot \frac{A}{2} + \cot \frac{B}{2} + \cot \frac{C}{2} = \cot \frac{A}{2} \cot \frac{B}{2} \cot \frac{C}{2}$
6. Given, in $\triangle ABC$, A, B and C are in an AP.
 $\therefore A + C = 2B$
 Also, $A + B + C = 180^\circ \Rightarrow B = 60^\circ$
 and $\sin(2A + B) = \sin(C - A)$
 $= -\sin(B + 2C) = \frac{1}{2} \dots(i)$
 $\Rightarrow \sin(2A + 60^\circ) = \sin(C - A) = -\sin(60^\circ + 2C) = \frac{1}{2}$
 $\Rightarrow 2A + 60^\circ = 30^\circ, 150^\circ$ [neglecting 30° , as not possible]
 $\Rightarrow 2A + 60^\circ = 150^\circ \Rightarrow A = 45^\circ$
 Again, from Eq. (i),
 $\sin(60^\circ + 2C) = -1/2$
 $\Rightarrow 60^\circ + 2C = 210^\circ, 330^\circ$
 $\Rightarrow C = 75^\circ$ or 135°
 Also, from Eq. (i),
 $\sin(C - A) = 1/2$
 $\Rightarrow C - A = 30^\circ, 150^\circ$
 For $A = 45^\circ, C = 75^\circ$
 and $C = 135^\circ$ [not possible]
 $\therefore C = 75^\circ$
 Hence, $A = 45^\circ, B = 60^\circ, C = 75^\circ$
7. LHS = $\sin^2 \alpha + \sin^2 \beta - \sin^2 \gamma = \sin^2 \alpha + (\sin^2 \beta - \sin^2 \gamma)$
 $= \sin^2 \alpha + \sin(\beta + \gamma) \sin(\beta - \gamma)$
 $= \sin^2 \alpha + \sin(\pi - \alpha) \sin(\beta - \gamma)$ [$\because \alpha + \beta + \gamma = \pi$]
 $= \sin^2 \alpha + \sin \alpha \sin(\beta - \gamma)$
 $= \sin \alpha [\sin \alpha + \sin(\beta - \gamma)]$
 $= \sin \alpha [\sin(\pi - (\beta + \gamma)) + \sin(\beta - \gamma)]$
 $= \sin \alpha [\sin(\beta + \gamma) + \sin(\beta - \gamma)]$
 $= \sin \alpha [2 \sin \beta \cos \gamma] = 2 \sin \alpha \sin \beta \cos \gamma = \text{RHS}$
8. Since, $A + B = 180^\circ - C$
 $\therefore \tan(A + B) = \tan(180^\circ - C)$
 $\Rightarrow \frac{\tan A + \tan B}{1 - \tan A \tan B} = -\tan C$

$$\Rightarrow \tan A + \tan B = -\tan C + \tan A \tan B \tan C$$

$$\Rightarrow \tan A + \tan B + \tan C = \tan A \tan B \tan C$$

9. Since, $\cos(\alpha + \beta) = \frac{4}{5}$
 and $\sin(\alpha - \beta) = \frac{5}{13}$
 $\therefore \tan(\alpha + \beta) = \frac{3}{4}$
 and $\tan(\alpha - \beta) = \frac{5}{12}$
 Now, $\tan 2\alpha = \tan[(\alpha + \beta) + (\alpha - \beta)]$
 $= \frac{\tan(\alpha + \beta) + \tan(\alpha - \beta)}{1 - \tan(\alpha + \beta) \cdot \tan(\alpha - \beta)} = \frac{\frac{3}{4} + \frac{5}{12}}{1 - \frac{3}{4} \cdot \frac{5}{12}} = \frac{56}{33}$

Topic 3 Maxima and Minima

1. Given expression $3 \cos \theta + 5 \sin\left(\theta - \frac{\pi}{6}\right)$
 $= 3 \cos \theta + 5\left(\sin \theta \cos \frac{\pi}{6} - \sin \frac{\pi}{6} \cos \theta\right)$
 $= 3 \cos \theta + 5\left(\frac{\sqrt{3}}{2} \sin \theta - \frac{1}{2} \cos \theta\right)$
 $= 3 \cos \theta - \frac{5}{2} \cos \theta + \frac{5\sqrt{3}}{2} \sin \theta$
 $= \frac{1}{2} \cos \theta + \frac{5\sqrt{3}}{2} \sin \theta$
 \therefore The maximum value of $a \cos \theta + b \sin \theta$ is $\sqrt{a^2 + b^2}$
 So, maximum value of $\frac{1}{2} \cos \theta + \frac{5\sqrt{3}}{2} \sin \theta$ is
 $= \sqrt{\left(\frac{1}{2}\right)^2 + \left(\frac{5\sqrt{3}}{2}\right)^2} = \sqrt{\frac{1}{4} + \frac{75}{4}} = \sqrt{\frac{76}{4}} = \sqrt{19}$.
2. As when $\theta \in \left(0, \frac{\pi}{4}\right)$, $\tan \theta < \cot \theta$
 Since, $\tan \theta < 1$ and $\cot \theta > 1$
 $\therefore (\tan \theta)^{\cot \theta} < 1$ and $(\cot \theta)^{\tan \theta} > 1$
 $\therefore t_4 > t_1$ which only holds in (b).
 Therefore, (b) is the answer.
3. Since, $A + B = \frac{\pi}{3}$ and, we know product of term is maximum, when values are equal.
 $\therefore (\tan A \cdot \tan B)$ is maximum.
 When $A = B = \pi/6$
 i.e. $y = \tan \frac{\pi}{6} \tan \frac{\pi}{6} = \frac{1}{3}$
4. Let $y = \frac{\sin x \cos 3x}{\sin 3x \cos x} = \frac{\tan x}{\tan 3x}$
 $\Rightarrow y = \frac{\tan x}{\tan 3x} = \frac{\tan x (1 - 3 \tan^2 x)}{3 \tan x - \tan^3 x}$
 $= \frac{1 - 3 \tan^2 x}{3 - \tan^2 x}$ [$\because x \neq 0$]

496 Trigonometrical Ratios and Identities

Put $\tan x = t$

$$\Rightarrow y = \frac{1 - 3t^2}{3 - t^2}$$

$$\Rightarrow 3y - t^2 y = 1 - 3t^2$$

$$\Rightarrow 3y - 1 = t^2 y - 3t^2$$

$$\Rightarrow 3y - 1 = t^2 (y - 3)$$

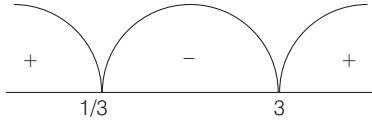

$$\Rightarrow \frac{3y - 1}{y - 3} = t^2 \Rightarrow \frac{3y - 1}{y - 3} > 0$$

$$\therefore t^2 > 0$$

NOTE It is a brilliant technique to convert equation into inequation and asked in IIT papers frequently.
 $\Rightarrow y < 1/3$ or $y > 3$. This shows that y cannot lie between $1/3$ and 3 .

Topic 4 Height & Distance

1. According to the question, we have the following figure.

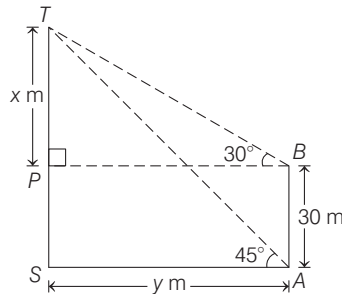

Now, let distance of foot of the tower from the point A is y m.

Draw $BP \perp ST$ such that $PT = x$ m.

Then, in $\triangle TPB$, we have

$$\tan 30^\circ = \frac{x}{y} \Rightarrow x = \frac{1}{\sqrt{3}} y \quad \dots(i)$$

and in $\triangle TSA$, we have $\tan 45^\circ = \frac{x + 30}{y}$

$$\Rightarrow y = x + 30 \quad \dots(ii)$$

On the elimination of quantity x from Eqs. (i) and (ii), we get

$$y = \frac{1}{\sqrt{3}} y + 30$$

$$\Rightarrow y \left(1 - \frac{1}{\sqrt{3}} \right) = 30$$

$$\Rightarrow y = \frac{30\sqrt{3}}{\sqrt{3} - 1} = \frac{30\sqrt{3}(\sqrt{3} + 1)}{3 - 1}$$

$$= \frac{30}{2} \sqrt{3} (\sqrt{3} + 1) = 15 (3 + \sqrt{3})$$

2. Given a ladder of length $l = 2$ m leans against a vertical wall. Now, the top of ladder begins to slide down the wall at the rate 25 cm/s.

Let the rate at which bottom of the ladder slides away from the wall on the horizontal ground is $\frac{dx}{dt}$ cm/s.

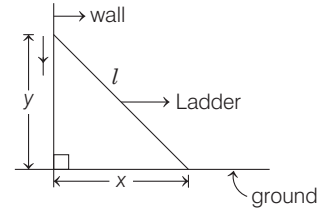

$$\therefore x^2 + y^2 = l^2$$

[by Pythagoras theorem]

$$\Rightarrow x^2 + y^2 = 4 \quad [\because l = 2\text{m}] \dots (i)$$

On differentiating both sides of Eq. (i) w.r.t. ' t ', we get

$$2x \frac{dx}{dt} + 2y \frac{dy}{dt} = 0$$

$$\Rightarrow \frac{dx}{dt} = - \left(\frac{y}{x} \right) \frac{dy}{dt} \quad \dots (ii)$$

From Eq. (i), when $y = 1$ m, then

$$x^2 + 1^2 = 4 \Rightarrow x^2 = 3 \Rightarrow x = \sqrt{3} \text{ m} \quad [\because x > 0]$$

On substituting $x = \sqrt{3}$ m and $y = 1$ m in Eq. (ii), we get

$$\begin{aligned} \frac{dx}{dt} &= - \frac{1}{\sqrt{3}} \left(- \frac{25}{100} \right) \text{ m/s} \quad \left[\text{given } \frac{dy}{dt} = -25 \text{ cm/sec} \right] \\ &= \frac{25}{\sqrt{3}} \text{ cm/s} \end{aligned}$$

3. Given ABC is a triangular park with $AB = AC = 100$ m. A vertical tower is situated at the mid-point of BC . Let the height of the tower is h m.

Now, according to given information, we have the following figure.

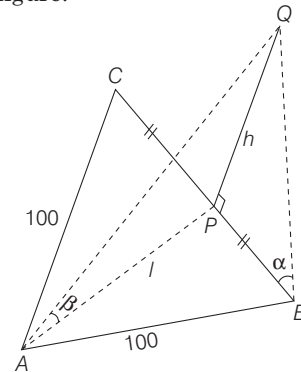

From the figure and given information, we have

$$\beta = \cot^{-1}(3\sqrt{2}) \quad \text{and} \quad \alpha = \operatorname{cosec}^{-1}(2\sqrt{2})$$

Now, in $\triangle QPA$,

$$\cot \beta = \frac{l}{h}$$

$$\Rightarrow l = (3\sqrt{2})h \quad \dots(i)$$

and in $\triangle BPQ$, $\tan \alpha = \frac{h}{BP}$

$$\Rightarrow \cot \alpha = \frac{BP}{h} = \frac{\sqrt{(100)^2 - l^2}}{h}$$

[\because p is mid-point of isosceles $\triangle ABC$, $AP \perp BC$]

$$\Rightarrow h^2 \cot^2 \alpha = (100)^2 - l^2$$

$$\Rightarrow h^2 (\operatorname{cosec}^2 \alpha - 1) = (100)^2 - (3\sqrt{2}h)^2 \quad [\text{from Eq. (i)}]$$

$$\Rightarrow h^2 (8 - 1) = (100)^2 - 18h^2$$

$$\Rightarrow 25h^2 = (100)^2$$

$$\Rightarrow h^2 = \left(\frac{100}{5}\right)^2 \Rightarrow h = 20 \text{ m}$$

4. Given heights of two poles are 5 m and 10 m.

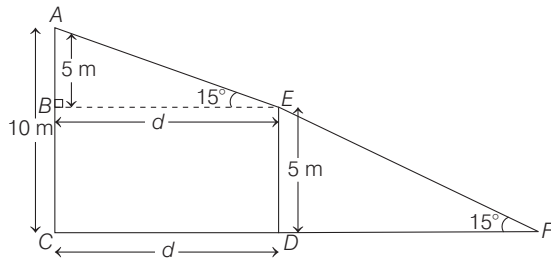

i.e. from figure $AC = 10 \text{ m}$, $DE = 5 \text{ m}$

$$\therefore AB = AC - DE = 10 - 5 = 5 \text{ m}$$

Let d be the distance between two poles.

Clearly, $\triangle ABE \sim \triangle ACF$

[by AA- similarity criterion]

$$\therefore \angle AEB = 15^\circ$$

In $\triangle ABE$, we have

$$\tan 15^\circ = \frac{AB}{BE} \Rightarrow \frac{\sqrt{3} - 1}{\sqrt{3} + 1} = \frac{5}{d} \quad [\because \tan 15^\circ = \frac{\sqrt{3} - 1}{\sqrt{3} + 1}]$$

$$\Rightarrow d = \frac{5(\sqrt{3} + 1)}{(\sqrt{3} - 1)}$$

$$\Rightarrow d = 5 \frac{\sqrt{3} + 1}{\sqrt{3} - 1} \times \frac{\sqrt{3} + 1}{\sqrt{3} + 1} = \frac{5(3 + 2\sqrt{3} + 1)}{3 - 1}$$

$$= \frac{5(2\sqrt{3} + 4)}{2} = \frac{2 \times 5(\sqrt{3} + 2)}{2} = 5(2 + \sqrt{3}) \text{ m}$$

5. Let a first pole AB having height 20 m and second pole PQ having height 80 m and $\angle PBQ = \alpha$, $\angle AQB = \beta$

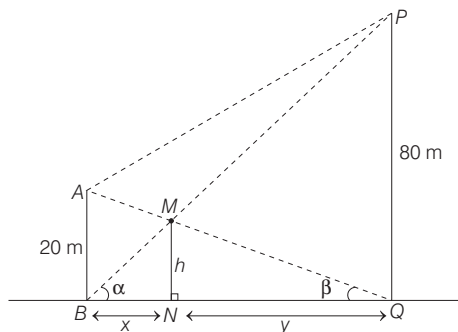

and $MN = hm$ is the height of intersection point from the horizontal plane

$$\therefore \tan \alpha = \frac{h}{x} = \frac{80}{x + y} \quad [\text{in } \triangle MNB \text{ and } \triangle PQB] \dots(i)$$

and $\tan \beta = \frac{h}{y} = \frac{20}{x + y}$

[in $\triangle MNQ$ and $\triangle ABQ$] $\dots(ii)$

From Eqs. (i) and (ii), we get

$$\frac{y}{x} = 4 \Rightarrow y = 4x \quad \dots(iii)$$

From Eqs. (i) and (iii), we get

$$\frac{h}{x} = \frac{80}{x + 4x} \Rightarrow h = \frac{80}{5} = 16 \text{ m}$$

6. According to given information, we have the following figure,

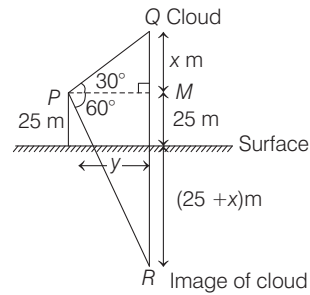

In $\triangle PQM$, $\tan 30^\circ = \frac{x}{y}$ $\dots(i)$

In $\triangle PRM$, $\tan 60^\circ = \frac{25 + (25 + x)}{y}$ $\dots(ii)$

On eliminating 'y' from Eqs. (i) and (ii), we get

$$\sqrt{3} = \frac{25 + (25 + x)}{\sqrt{3}x}$$

$$\Rightarrow 3x = 50 + x \Rightarrow 2x = 50 \Rightarrow x = 25 \text{ m.}$$

\therefore Height of cloud from surface = $x + 25 = 50 \text{ m}$.

7. According to given information, we have the following figure.

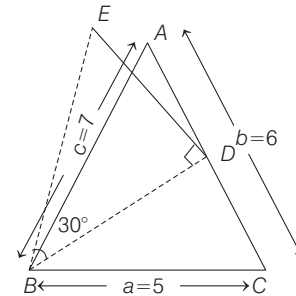

Clearly, length of $BD = \frac{1}{2} \sqrt{2a^2 + 2c^2 - b^2}$,

(using Apollonius theorem)

where, $c = AB = 7$, $a = BC = 5$

and $b = CA = 6$

$$\therefore BD = \frac{1}{2} \sqrt{2 \times 25 + 2 \times 49 - 36}$$

498 Trigonometrical Ratios and Identities

$$= \frac{1}{2} \sqrt{112} = \frac{1}{2} 4\sqrt{7} = 2\sqrt{7}$$

Now, let $ED = h$ be the height of the lamp post.

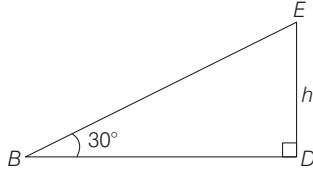

Then, in $\triangle BDE$, $\tan 30^\circ = \frac{h}{BD}$

$$\Rightarrow \frac{1}{\sqrt{3}} = \frac{h}{2\sqrt{7}}$$

$$\Rightarrow h = \frac{2\sqrt{7}}{\sqrt{3}} = \frac{2}{3}\sqrt{21}$$

8.

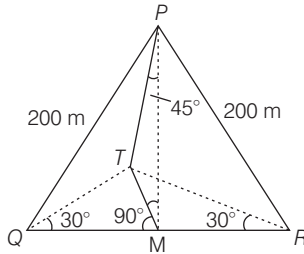

Let height of tower TM be h .

In $\triangle PMT$, $\tan 45^\circ = \frac{TM}{PM}$

$$\Rightarrow 1 = \frac{h}{PM} \Rightarrow PM = h$$

In $\triangle TQM$, $\tan 30^\circ = \frac{h}{QM}$; $QM = \sqrt{3}h$

In $\triangle PMQ$, $PM^2 + QM^2 = PQ^2$
 $h^2 + (\sqrt{3}h)^2 = (200)^2$

$$\Rightarrow 4h^2 = (200)^2 \Rightarrow h = 100 \text{ m}$$

9. Let $AB = h$, then $AP = 2h$

and $AC = BC = \frac{h}{2}$

Again, let $\angle CPA = \alpha$

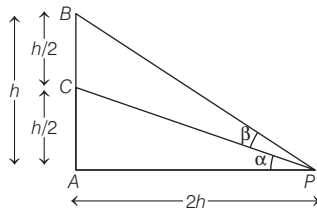

Now, in $\triangle ABP$, $\tan(\alpha + \beta) = \frac{AB}{AP}$
 $= \frac{h}{2h} = \frac{1}{2}$

Also, in $\triangle ACP$, $\tan \alpha = \frac{AC}{AP} = \frac{\frac{h}{2}}{2h} = \frac{1}{4}$

Now, $\tan \beta = \tan[(\alpha + \beta) - \alpha]$
 $= \frac{\tan(\alpha + \beta) - \tan \alpha}{1 + \tan(\alpha + \beta) \tan \alpha}$
 $= \frac{\frac{1}{2} - \frac{1}{4}}{1 + \frac{1}{2} \times \frac{1}{4}} = \frac{\frac{1}{4}}{\frac{9}{8}} = \frac{2}{9}$

10. According to given information, we have the following figure

Now, from $\triangle ACD$ and $\triangle BCD$, we have

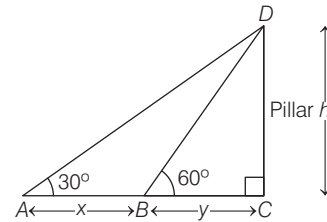

$$\tan 30^\circ = \frac{h}{x + y}$$

and $\tan 60^\circ = \frac{h}{y}$

$$\Rightarrow h = \frac{x + y}{\sqrt{3}} \quad \dots(i)$$

$$\text{and} \quad h = \sqrt{3} y \quad \dots(ii)$$

From Eqs. (i) and (ii), $\frac{x + y}{\sqrt{3}} = \sqrt{3} y$

$$\Rightarrow x + y = 3y$$

$$\Rightarrow x - 2y = 0$$

$$\Rightarrow y = \frac{x}{2}$$

\therefore Speed is uniform

and distance x covered in 10 min.

\therefore Distance $\frac{x}{2}$ will be cover in 5 min.

\therefore Distance y will be cover in 5 min.

21

Trigonometrical Equations

Topic 1 General Solution

Objective Questions I (Only one correct option)

1. If the equation $\cos^4 \theta + \sin^4 \theta + \lambda = 0$ has real solutions for θ , then λ lies in the interval (2020 Main, 2 Sep II)

(a) $\left(-\frac{5}{4}, -1\right)$ (b) $\left[-1, -\frac{1}{2}\right]$
(c) $\left(-\frac{1}{2}, -\frac{1}{4}\right)$ (d) $\left[-\frac{3}{2}, -\frac{5}{4}\right]$

2. Let S be the set of all $\alpha \in R$ such that the equation, $\cos 2x + \alpha \sin x = 2\alpha - 7$ has a solution. Then, S is equal to (2019 Main, 12 April II)

(a) R (b) $[1, 4]$ (c) $[3, 7]$ (d) $[2, 6]$

3. The number of solutions of the equation

$1 + \sin^4 x = \cos^2 3x$, $x \in \left[-\frac{5\pi}{2}, \frac{5\pi}{2}\right]$ is (2019 Main, 12 April I)

(a) 3 (b) 5 (c) 7 (d) 4

4. Let $S = \{\theta \in [-2\pi, 2\pi] : 2 \cos^2 \theta + 3 \sin \theta = 0\}$, then the sum of the elements of S is (2019 Main, 9 April I)

(a) 2π (b) π (c) $\frac{5\pi}{3}$ (d) $\frac{13\pi}{6}$

5. If $\sin^4 \alpha + 4 \cos^4 \beta + 2 = 4\sqrt{2} \sin \alpha \cos \beta$; $\alpha, \beta \in [0, \pi]$, then $\cos(\alpha + \beta) - \cos(\alpha - \beta)$ is equal to (2019 Main, 12 Jan II)

(a) -1 (b) $\sqrt{2}$ (c) $-\sqrt{2}$ (d) 0

6. Let α and β be the roots of the quadratic equation $x^2 \sin \theta - x(\sin \theta \cos \theta + 1) + \cos \theta = 0$ ($0 < \theta < 45^\circ$) and

$\alpha < \beta$. Then, $\sum_{n=0}^{\infty} \left(\alpha^n + \frac{(-1)^n}{\beta^n}\right)$ is equal to (2019 Main, 11 Jan II)

(a) $\frac{1}{1 - \cos \theta} - \frac{1}{1 + \sin \theta}$ (b) $\frac{1}{1 - \cos \theta} + \frac{1}{1 + \sin \theta}$
(c) $\frac{1}{1 + \cos \theta} - \frac{1}{1 - \sin \theta}$ (d) $\frac{1}{1 + \cos \theta} + \frac{1}{1 - \sin \theta}$

7. The sum of all values of $\theta \in \left(0, \frac{\pi}{2}\right)$ satisfying

$\sin^2 2\theta + \cos^4 2\theta = \frac{3}{4}$ is (2019 Main, 10 Jan I)

(a) $\frac{3\pi}{8}$ (b) $\frac{5\pi}{4}$ (c) $\frac{\pi}{2}$ (d) π

8. If $0 \leq x < \frac{\pi}{2}$, then the number of values of x for which $\sin x - \sin 2x + \sin 3x = 0$, is (2019 Main, 9 Jan II)

(a) 2 (b) 3 (c) 1 (d) 4

9. If sum of all the solutions of the equation

$8 \cos x \cdot \left(\cos\left(\frac{\pi}{6} + x\right) \cdot \cos\left(\frac{\pi}{6} - x\right) - \frac{1}{2}\right) = 1$

in $[0, \pi]$ is $k\pi$, then k is equal to (2018 Main)

(a) $\frac{2}{3}$ (b) $\frac{13}{9}$ (c) $\frac{8}{9}$ (d) $\frac{20}{9}$

10. If $5(\tan^2 x - \cos^2 x) = 2 \cos 2x + 9$, then the value of $\cos 4x$ is (2017 Main)

(a) $-\frac{3}{5}$ (b) $\frac{1}{3}$ (c) $\frac{2}{9}$ (d) $-\frac{7}{9}$

11. If $0 \leq x < 2\pi$, then the number of real values of x , which satisfy the equation

$\cos x + \cos 2x + \cos 3x + \cos 4x = 0$, is (2016 Main)

(a) 3 (b) 5 (c) 7 (d) 9

12. Let $S = \left\{x \in (-\pi, \pi) : x \neq 0, \pm \frac{\pi}{2}\right\}$. The sum of all

distinct solutions of the equation $\sqrt{3} \sec x + \operatorname{cosec} x + 2(\tan x - \cot x) = 0$ in the set S is equal to (2016 Adv.)

(a) $-\frac{7\pi}{9}$ (b) $-\frac{2\pi}{9}$ (c) 0 (d) $\frac{5\pi}{9}$

13. If $P = \{\theta : \sin \theta - \cos \theta = \sqrt{2} \cos \theta\}$ and

$Q = \{\theta : \sin \theta + \cos \theta = \sqrt{2} \sin \theta\}$ be two sets. Then, (2011)

(a) $P \subset Q$ and $Q - P \neq \phi$ (b) $Q \subset P$
(c) $P \not\subset Q$ (d) $P = Q$

14. Let n be an odd integer. If $\sin n\theta = \sum_{r=0}^n b_r \sin^r \theta$, for every value of θ , then (1998, 2M)

(a) $b_0 = 1, b_1 = 3$ (b) $b_0 = 0, b_1 = n$
(c) $b_0 = -1, b_1 = n$ (d) $b_0 = 0, b_1 = n^2 - 3n + 3$

15. The general value of θ satisfying the equation $2 \sin^2 \theta - 3 \sin \theta - 2 = 0$, is (1995, 2M)

(a) $n\pi + (-1)^n \frac{\pi}{6}$ (b) $n\pi + (-1)^n \frac{\pi}{2}$
(c) $n\pi + (-1)^n \frac{5\pi}{6}$ (d) $n\pi + (-1)^n \frac{7\pi}{6}$

500 Trigonometrical Equations

16. In a $\triangle ABC$, angle A is greater than angle B . If the measures of angles A and B satisfy the equation $3\sin x - 4\sin^3 x - k = 0, 0 < k < 1$, then the measure of $\angle C$ is (1990, 2M)
- (a) $\frac{\pi}{3}$ (b) $\frac{\pi}{2}$ (c) $\frac{2\pi}{3}$ (d) $\frac{5\pi}{6}$
17. The general solution of $\sin x - 3\sin 2x + \sin 3x = \cos x - 3\cos 2x + \cos 3x$ is (1989, 2M)
- (a) $n\pi + \frac{\pi}{8}$ (b) $\frac{n\pi}{2} + \frac{\pi}{8}$
- (c) $(-1)^n \frac{n\pi}{2} + \frac{\pi}{8}$ (d) $2n\pi + \cos^{-1} \frac{3}{2}$
18. The general solution of the trigonometric equation $\sin x + \cos x = 1$ is given by (1981, 2M)
- (a) $x = 2n\pi; n = 0, \pm 1, \pm 2, \dots$
- (b) $x = 2n\pi + \pi/2; n = 0, \pm 1, \pm 2, \dots$
- (c) $x = n\pi + (-1)^n \frac{\pi}{4} - \frac{\pi}{4}; n = 0, \pm 1, \pm 2, \dots$
- (d) None of the above
19. The equation $2\cos^2\left(\frac{x}{2}\right)\sin^2 x = x^2 + x^{-2}, x \leq \frac{\pi}{9}$ has (1980, 1M)
- (a) no real solution
- (b) one real solution
- (c) more than one real solution
- (d) None of the above

Objective Questions II

(One or more than one correct option)

20. Let α and β be non zero real numbers such that $2(\cos\beta - \cos\alpha) + \cos\alpha\cos\beta = 1$. Then which of the following is/are true? (2017 Adv.)
- (a) $\sqrt{3}\tan\left(\frac{\alpha}{2}\right) - \tan\left(\frac{\beta}{2}\right) = 0$
- (b) $\tan\left(\frac{\alpha}{2}\right) - \sqrt{3}\tan\left(\frac{\beta}{2}\right) = 0$
- (c) $\tan\left(\frac{\alpha}{2}\right) + \sqrt{3}\tan\left(\frac{\beta}{2}\right) = 0$
- (d) $\sqrt{3}\tan\left(\frac{\alpha}{2}\right) + \tan\left(\frac{\beta}{2}\right) = 0$
21. The values of θ lying between $\theta = 0$ and $\theta = \pi/2$ and satisfying the equation
- $$\begin{vmatrix} 1 + \sin^2\theta & \cos^2\theta & 4\sin 4\theta \\ \sin^2\theta & 1 + \cos^2\theta & 4\sin 4\theta \\ \sin^2\theta & \cos^2\theta & 1 + 4\sin 4\theta \end{vmatrix} = 0, \text{ is}$$
- (1988, 3M)
- (a) $7\pi/24$ (b) $5\pi/24$ (c) $11\pi/24$ (d) $\pi/24$

Integer & Numerical Answer Type Questions

22. Let a, b, c be three non-zero real numbers such that the equation $\sqrt{3}a\cos x + 2b\sin x = c, x \in \left[-\frac{\pi}{2}, \frac{\pi}{2}\right]$ has two distinct real roots α and β with $\alpha + \beta = \frac{\pi}{3}$. Then, the value of $\frac{b}{a}$ is (2018 Adv.)

23. The number of distinct solutions of the equation $\frac{5}{4}\cos^2 2x + \cos^4 x + \sin^4 x + \cos^6 x + \sin^6 x = 2$ in the interval $[0, 2\pi]$ is (2015 Adv.)

Match the Columns

24. Let $f(x) = \sin(\pi \cos x)$ and $g(x) = \cos(2\pi \sin x)$ be two functions defined for $x > 0$. Define the following sets whose elements are written in the increasing order :

$$X = \{x : f(x) = 0\}, Y = \{x : f'(x) = 0\}$$

$$Z = \{x : g(x) = 0\}, W = \{x : g'(x) = 0\}$$

List-I contains the sets X, Y, Z and W . List-II contains some information regarding these sets. (2019 Adv.)

	List-I	List-II
(I)	X	(P) $\supseteq \left\{\frac{\pi}{2}, \frac{3\pi}{2}, 4\pi, 7\pi\right\}$
(II)	Y	(Q) an arithmetic progression
(III)	Z	(R) NOT an arithmetic progression
(IV)	W	(S) $\supseteq \left\{\frac{\pi}{6}, \frac{7\pi}{6}, \frac{13\pi}{6}\right\}$
		(T) $\supseteq \left\{\frac{\pi}{3}, \frac{2\pi}{3}, \pi\right\}$
		(U) $\supseteq \left\{\frac{\pi}{6}, \frac{3\pi}{4}\right\}$

Which of the following is the only CORRECT combination?

- (a) (IV), (P), (R), (S)
- (b) (III), (P), (Q), (U)
- (c) (III), (R), (U)
- (d) (IV), (Q), (T)
25. Let $f(x) = \sin(\pi \cos x)$ and $g(x) = \cos(2\pi \sin x)$ be two functions defined for $x > 0$. Define the following sets whose elements are written in the increasing order :
- $X = \{x : f(x) = 0\}, Y = \{x : f'(x) = 0\}$
- $Z = \{x : g(x) = 0\}, W = \{x : g'(x) = 0\}$
- List-I contains the sets X, Y, Z and W . List-II contains some information regarding these sets. (2019 Adv.)

	List-I	List-II
(I)	X	(P) $\supseteq \left\{\frac{\pi}{2}, \frac{3\pi}{2}, 4\pi, 7\pi\right\}$
(II)	Y	(Q) an arithmetic progression
(III)	Z	(R) NOT an arithmetic progression
(IV)	W	(S) $\supseteq \left\{\frac{\pi}{6}, \frac{7\pi}{6}, \frac{13\pi}{6}\right\}$
		(T) $\supseteq \left\{\frac{\pi}{3}, \frac{2\pi}{3}, \pi\right\}$
		(U) $\supseteq \left\{\frac{\pi}{6}, \frac{3\pi}{4}\right\}$

Which of the following is the only CORRECT combination?

- (a) (I), (Q), (T)
 (b) (I), (R), (S)
 (c) (I), (P), (R)
 (d) (I), (Q), (U)

Fill in the Blank

26. General value of θ satisfying the equation $\tan^2 \theta + \sec 2\theta = 1$ is..... (1996, 1M)

True/False

27. There exists a value of θ between 0 and 2π that satisfies the equation $\sin^4 \theta - 2 \sin^2 \theta + 1 = 0$. (1984, 1M)

Analytical & Descriptive Questions

28. Determine the smallest positive value of x (in degrees) for which $\tan(x+100^\circ) = \tan(x+50^\circ) \tan(x) \tan(x-50^\circ)$. (1993, 5M)

29. If $\exp\{(\sin^2 x + \sin^4 x + \sin^6 x + \dots \infty) \log_e 2\}$, satisfies the equation $x^2 - 9x + 8 = 0$, find the value of $\frac{\cos nx}{\cos x + \sin x}$, $0 < x < \frac{\pi}{2}$. (1991, 4M)

30. Consider the system of linear equations in x, y, z

$$\begin{aligned}(\sin 3\theta)x - y + z &= 0, \\(\cos 2\theta)x + 4y + 3z &= 0, \\2x + 7y + 7z &= 0\end{aligned}$$

Find the values of θ for which this system has non-trivial solutions. (1986, 4M)

31. Find the values of x ($-\pi, \pi$) which satisfy the equation $2^{1+|\cos x|+|\cos^2 x|+\dots} = 4$ (1984, 2M)

32. Find all the solutions of $4\cos^2 x \sin x - 2\sin^2 x = 3\sin x$. (1983, 2M)

33. Solve $2(\cos x + \cos 2x) + (1 + 2\cos x)\sin 2x = 2\sin x$, $-\pi \leq x \leq \pi$ (1978, 3M)

Topic 2 Solving Equations with Graph

Objective Question I (Only one correct option)

1. All x satisfying the inequality $(\cot^{-1} x)^2 - 7(\cot^{-1} x) + 10 > 0$, lie in the interval (2019 Main, 11 Jan II)
- (a) $(-\infty, \cot 5) \cup (\cot 2, \infty)$ (b) $(\cot 5, \cot 4)$
 (c) $(\cot 2, \infty)$
 (d) $(-\infty, \cot 5) \cup (\cot 4, \cot 2)$
2. The set of values of θ satisfying the inequation $2\sin^2 \theta - 5\sin \theta + 2 > 0$, where $0 < \theta < 2\pi$, is (2006, 3M)
- (a) $\left(0, \frac{\pi}{6}\right) \cup \left(\frac{5\pi}{6}, 2\pi\right)$ (b) $\left[0, \frac{\pi}{6}\right] \cup \left[\frac{5\pi}{6}, 2\pi\right]$
 (c) $\left[0, \frac{\pi}{3}\right] \cup \left[\frac{2\pi}{3}, 2\pi\right]$ (d) None of these

Objective Question II

(One or more than one correct option)

3. Let, $f(x) = \frac{\sin \pi x}{x^2}$, $x > 0$

Let $x_1 < x_2 < x_3 < \dots < x_n < \dots$ be all the points of local maximum of f and $y_1 < y_2 < y_3 < \dots < y_n < \dots$ be all the points of local minimum of f .

Then which of the following options is/are correct?

- (a) $|x_n - y_n| > 1$ for every n (2019 Adv.)

- (b) $x_{n+1} - x_n > 2$ for every n

- (c) $x_1 < y_1$

- (d) $x_n \in \left(2n, 2n + \frac{1}{2}\right)$ for every n

4. Let $\theta, \phi \in [0, 2\pi]$ be such that $2\cos \theta (1 - \sin \phi) = \sin^2 \theta$

$$\left(\tan \frac{\theta}{2} + \cot \frac{\theta}{2}\right) \cos \phi - 1, \tan(2\pi - \theta) > 0$$

and $-1 < \sin \theta < -\frac{\sqrt{3}}{2}$. Then, ϕ cannot satisfy (2012)

- (a) $0 < \phi < \frac{\pi}{2}$

- (b) $\frac{\pi}{2} < \phi < \frac{4\pi}{3}$

- (c) $\frac{4\pi}{3} < \phi < \frac{3\pi}{2}$

- (d) $\frac{3\pi}{2} < \phi < 2\pi$

Analytical & Descriptive Question

5. Find all values of θ in the interval $\left(-\frac{\pi}{2}, \frac{\pi}{2}\right)$ satisfying

$$\text{the equation } (1 - \tan \theta)(1 + \tan \theta) \sec^2 \theta + 2^{\tan^2 \theta} = 0.$$

(1996, 2M)

Topic 3 Problems Based on Maximum and Minimum

Objective Questions I (Only one correct option)

- For $x \in (0, \pi)$, the equation $\sin x + 2 \sin 2x - \sin 3x = 3$ has
(a) infinitely many solutions (2014 Adv.)
(b) three solutions
(c) one solution
(d) no solution
- The number of solutions of the pair of equations $2 \sin^2 \theta - \cos 2\theta = 0$ and $2 \cos^2 \theta - 3 \sin \theta = 0$ in the interval $[0, 2\pi]$ is (2007, 3M)
(a) 0 (b) 1 (c) 2 (d) 4
- The number of integral values of k for which the equation $7 \cos x + 5 \sin x = 2k + 1$ has a solution, is (2002, 1M)
(a) 4 (b) 8 (c) 10 (d) 12
- The number of values of x in the interval $[0, 5\pi]$ satisfying the equation $3 \sin^2 x - 7 \sin x + 2 = 0$ is (1998, 2M)
(a) 0 (b) 5 (c) 6 (d) 10
- Number of solutions of the equation $\tan x + \sec x = 2 \cos x$ lying in the interval $[0, 2\pi]$ is (1993, 1M)
(a) 0 (b) 1 (c) 2 (d) 3
- The number of solutions of the equation $\sin(e^x) = 5^x + 5^{-x}$ is (1991, 2M)
(a) 0 (b) 1
(c) 2 (d) infinitely many
- The equation $(\cos p - 1)x^2 + (\cos p)x + \sin p = 0$ in the variable x , has real roots. Then, p can take any value in the interval (1990, 2M)
(a) $(0, 2\pi)$ (b) $(-\pi, 0)$ (c) $(-\frac{\pi}{2}, \frac{\pi}{2})$ (d) $(0, \pi)$
- The smallest positive root of the equation $\tan x - x = 0$ lies in (1987, 2M)
(a) $(0, \frac{\pi}{2})$ (b) $(\frac{\pi}{2}, \pi)$ (c) $(\pi, \frac{3\pi}{2})$ (d) $(\frac{3\pi}{2}, 2\pi)$
- The number of all possible triplets (a_1, a_2, a_3) such that $a_1 + a_2 \cos(2x) + a_3 \sin^2(x) = 0, \forall x$ is (1987, 2M)
(a) 0 (b) 1 (c) 3 (d) ∞

Objective Questions II

(One or more than one correct option)

- $\sec^2 \theta = \frac{4xy}{(x+y)^2}$ is true if and only if (1996, 1M)
(a) $x = y \neq 0$ (b) $x = y, x \neq 0$
(c) $x = y$ (d) $x \neq 0, y \neq 0$
- For $0 < \phi < \pi/2$, if $x = \sum_{n=0}^{\infty} \cos^{2n} \phi, y = \sum_{n=0}^{\infty} \sin^{2n} \phi,$
 $z = \sum_{n=0}^{\infty} \cos^{2n} \phi \sin^{2n} \phi,$ then (1993, 2M)

- $xyz = xz + y$
- $xyz = xy + z$
- $xyz = x + y + z$
- $xyz = yz + x$

Integer & Numerical Answer Type Questions

- Let $f : [0, 2] \rightarrow \mathbf{R}$ be the function defined by
 $f(x) = (3 - \sin(2\pi x)) \sin\left(\pi x - \frac{\pi}{4}\right) - \sin\left(3\pi x + \frac{\pi}{4}\right).$
If $\alpha, \beta \in [0, 2]$ are such that $\{x \in [0, 2] : f(x) \geq 0\} = [\alpha, \beta],$ then the value of $\beta - \alpha$ is (2020 Adv.)
- The positive integer value of $n > 3$ satisfying the equation $\frac{1}{\sin\left(\frac{\pi}{n}\right)} = \frac{1}{\sin\left(\frac{2\pi}{n}\right)} + \frac{1}{\sin\left(\frac{3\pi}{n}\right)}$ is (2011)
- The number of values of θ in the interval $\left(-\frac{\pi}{2}, \frac{\pi}{2}\right)$ such that $\theta \neq \frac{n\pi}{5}$ for $n = 0, \pm 1, \pm 2$ and $\tan \theta = \cot 5\theta$ as well as $\sin 2\theta = \cos 4\theta$ is (2010)

Fill in the Blanks

- The set of all x in the interval $[0, \pi]$ for which $2 \sin^2 x - 3 \sin x + 1 \geq 0,$ is (1987, 2M)
- The solution set of the system of equations $x + y = \frac{2\pi}{3}, \cos x + \cos y = \frac{3}{2},$ where x and y are real, is
- The larger of $\cos(\log \theta)$ and $\log(\cos \theta)$ if $-\frac{\pi}{2} < \theta < \frac{\pi}{2},$ is (1983, 1M)

Analytical & Descriptive Questions

- Find the smallest positive number p for which the equation $\cos(p \sin x) = \sin(p \cos x)$ has a solution $x \in [0, 2\pi].$ (1995, 5M)
- Show that the equation $e^{\sin x} - e^{-\sin x} - 4 = 0$ has no real solution. (1982, 2M)
- Find the coordinates of the points of intersection of the curves $y = \cos x, y = \sin 3x,$ if $-\frac{\pi}{2} \leq x \leq \frac{\pi}{2}.$ (1982, 3M)
- For all θ in $[0, \pi/2],$ show that $\cos(\sin \theta) \geq \sin(\cos \theta).$ (1981, 4M)
- Prove that $5 \cos \theta + 3 \cos\left(\theta + \frac{\pi}{3}\right) + 3$ lies between -4 and $10.$ (1979, 3M)

Answers

Topic 1

1. (b) 2. (d) 3. (b) 4. (a)
 5. (c) 6. (b) 7. (c) 8. (a)
 9. (b) 10. (d) 11. (c) 12. (c)
 13. (d) 14. (b) 15. (d) 16. (c)
 17. (b) 18. (c) 19. (a) 20. (b, c)
 21. (a, c) 22. (0.5) 23. (8) 24. (a)
 25. (a) 26. $\theta = m\pi, n\pi \pm \frac{\pi}{3}$ 27. False

28. $x = 30^\circ$ 29. $\frac{\sqrt{3}-1}{2}$

30. $\theta = n\pi$ or $n\pi + (-1)^n \left(\frac{\pi}{6}\right)$ 31. $\left\{\pm \frac{\pi}{3}, \pm \frac{2\pi}{3}\right\}$

32. $\{x : x = n\pi\} \cup \left\{x : x = n\pi + (-1)^n \frac{\pi}{10}\right\}$
 $\cup \left\{x : x = n\pi + (-1)^n \left(\frac{-3\pi}{10}\right)\right\}$

33. $x = -\pi, -\frac{\pi}{2}, -\frac{\pi}{3}, \frac{\pi}{3}, \pi$

Topic 2

1. (c) 2. (a) 3. (a,b,d)
 4. (a,c,d) 5. $\theta = \pm \pi/3$

Topic 3

1. (d) 2. (c) 3. (b) 4. (c)
 5. (c) 6. (a) 7. (d) 8. (c)
 9. (d) 10. (a, b) 11. (b, c) 12. (1)
 13. (7) 14. (3)

15. $x \in \left[0, \frac{\pi}{6}\right] \cup \left\{\frac{\pi}{2}\right\} \cup \left[\frac{5\pi}{6}, \pi\right]$ 16. No solution

17. $\cos(\log \theta)$ 18. Smallest positive value of $p = \frac{\pi}{2\sqrt{2}}$

20. $\left(\frac{\pi}{8}, \cos \frac{\pi}{8}\right) \left(\frac{\pi}{4}, \cos \frac{\pi}{4}\right) \left(-\frac{3\pi}{8}, \cos \frac{3\pi}{8}\right)$

Hints & Solutions

Topic 1 General Solution

1. The expression, $\cos^4 \theta + \sin^4 \theta$
 $= (\cos^2 \theta + \sin^2 \theta)^2 - 2\sin^2 \theta \cos^2 \theta$
 $= 1 - \frac{1}{2} \sin^2(2\theta)$
 $\therefore \sin^2(2\theta) \in [0, 1]$
 $\Rightarrow -\frac{1}{2} \sin^2(2\theta) \in \left[-\frac{1}{2}, 0\right]$
 $\Rightarrow 1 - \frac{1}{2} \sin^2(2\theta) \in \left[\frac{1}{2}, 1\right]$
 Now, as $\cos^4 \theta + \sin^4 \theta + \lambda = 0$
 $\Rightarrow \lambda = -(\cos^4 \theta + \sin^4 \theta)$
 $\Rightarrow \lambda \in [-1, -1/2]$ for real solution of the given equation
 $\cos^4 \theta + \sin^4 \theta + \lambda = 0$ for θ .
 Hence, option (b) is correct.

2. The given trigonometric equation is
 $\cos 2x + \alpha \sin x = 2\alpha - 7$
 $\Rightarrow 1 - 2\sin^2 x + \alpha \sin x = 2\alpha - 7$
 $\quad \quad \quad [\because \cos 2x = 1 - 2\sin^2 x]$
 $\Rightarrow 2\sin^2 x - \alpha \sin x + 2\alpha - 8 = 0$
 $\Rightarrow 2(\sin^2 x - 4) - \alpha(\sin x - 2) = 0$
 $\Rightarrow 2(\sin x - 2)(\sin x + 2) - \alpha(\sin x - 2) = 0$
 $\Rightarrow (\sin x - 2)(2\sin x + 4 - \alpha) = 0$
 $\therefore 2\sin x + 4 - \alpha = 0 \quad [\because \sin x - 2 \neq 0]$
 $\Rightarrow \sin x = \frac{\alpha - 4}{2} \quad \dots(i)$

Now, as we know $-1 \leq \sin x \leq 1$

$\therefore -1 \leq \frac{\alpha - 4}{2} \leq 1$ [from Eq. (i)]

$\Rightarrow -2 \leq \alpha - 4 \leq 2 \Rightarrow 2 \leq \alpha \leq 6 \Rightarrow \alpha \in [2, 6]$

3. Given equation is $1 + \sin^4 x = \cos^2(3x)$

Since, range of $(1 + \sin^4 x) = [1, 2]$

and range of $\cos^2(3x) = [0, 1]$

So, the given equation holds if

$1 + \sin^4 x = 1 = \cos^2(3x)$
 $\Rightarrow \sin^4 x = 0$ and $\cos^2 3x = 1$

Since, $x \in \left[-\frac{5\pi}{2}, \frac{5\pi}{2}\right]$

$\therefore x = -2\pi, -\pi, 0, \pi, 2\pi.$

Thus, there are five different values of x is possible.

4. We have, $\theta \in [-2\pi, 2\pi]$

and $2\cos^2 \theta + 3\sin \theta = 0$

$\Rightarrow 2(1 - \sin^2 \theta) + 3\sin \theta = 0$

$\Rightarrow 2 - 2\sin^2 \theta + 3\sin \theta = 0$

$\Rightarrow 2\sin^2 \theta - 3\sin \theta - 2 = 0$

$\Rightarrow 2\sin^2 \theta - 4\sin \theta + \sin \theta - 2 = 0$

$\Rightarrow 2\sin \theta(\sin \theta - 2) + 1(\sin \theta - 2) = 0$

$\Rightarrow (\sin \theta - 2)(2\sin \theta + 1) = 0$

$\therefore \sin \theta = \frac{-1}{2}$ [$\because (\sin \theta - 2) \neq 0$]

504 Trigonometrical Equations

$$\therefore \theta = 2\pi - \frac{\pi}{6}, -\pi + \frac{\pi}{6}, -\frac{\pi}{6}, \pi + \frac{\pi}{6} \quad [\because \theta \in [-2\pi, 2\pi]]$$

Now, sum of all solutions

$$= 2\pi - \frac{\pi}{6} - \pi + \frac{\pi}{6} - \frac{\pi}{6} + \pi + \frac{\pi}{6} = 2\pi$$

5. By applying AM \geq GM inequality, on the numbers

$\sin^4 \alpha, 4 \cos^4 \beta, 1$ and 1 , we get

$$\frac{\sin^4 \alpha + 4 \cos^4 \beta + 2}{4} \geq ((\sin^4 \alpha)(4 \cos^4 \beta) \cdot 1 \cdot 1)^{1/4}$$

$$\Rightarrow \sin^4 \alpha + 4 \cos^4 \beta + 2 \geq 4\sqrt{2} \sin \alpha \cos \beta$$

But, it is given that

$$\sin^4 \alpha + 4 \cos^4 \beta + 2 = 4\sqrt{2} \sin \alpha \cos \beta$$

So, $\sin^4 \alpha = 4 \cos^4 \beta = 1$

[\because In AM \geq GM, equality holds when all given positive quantities are equal.]

$$\Rightarrow \sin \alpha = 1 \text{ and } \sin \beta = \frac{1}{\sqrt{2}} \quad \dots(i)$$

[$\because \alpha, \beta \in [0, \pi]$]

Now, $\cos(\alpha + \beta) - \cos(\alpha - \beta) = -2 \sin \alpha \sin \beta$

$$\left[\because \cos C - \cos D = 2 \sin \frac{C+D}{2} \sin \frac{D-C}{2} \right]$$

$$= -2 \times 1 \times \frac{1}{\sqrt{2}} \quad [\text{from Eq. (i)}]$$

$$= -\sqrt{2}$$

6. Given,

$$x^2 \sin \theta - x \sin \theta \cos \theta - x + \cos \theta = 0,$$

where $0 < \theta < 45^\circ$

$$\Rightarrow x \sin \theta (x - \cos \theta) - 1(x - \cos \theta) = 0$$

$$\Rightarrow (x - \cos \theta)(x \sin \theta - 1) = 0$$

$$\Rightarrow x = \cos \theta, x = \operatorname{cosec} \theta$$

$$\Rightarrow \alpha = \cos \theta \text{ and } \beta = \operatorname{cosec} \theta$$

(\because For $0 < \theta < 45^\circ$, $\frac{1}{\sqrt{2}} < \cos \theta < 1$ and $\sqrt{2} < \operatorname{cosec} \theta < \infty$)

$\Rightarrow \cos \theta < \operatorname{cosec} \theta$)

$$\begin{aligned} \text{Now, consider, } \sum_{n=0}^{\infty} \left(\alpha^n + \frac{(-1)^n}{\beta^n} \right) &= \sum_{n=0}^{\infty} \alpha^n + \sum_{n=0}^{\infty} \frac{(-1)^n}{\beta^n} \\ &= (1 + \alpha + \alpha^2 + \alpha^3 + \dots \infty) \\ &\quad + \left(1 - \frac{1}{\beta} + \frac{1}{\beta^2} - \frac{1}{\beta^3} + \dots \infty \right) \end{aligned}$$

$$\begin{aligned} &= \frac{1}{1-\alpha} + \frac{1}{1-\left(-\frac{1}{\beta}\right)} = \frac{1}{1-\alpha} + \frac{1}{1+\frac{1}{\beta}} \\ &= \frac{1}{1-\cos \theta} + \frac{1}{1+\sin \theta} \quad \left\{ \because \frac{1}{\beta} = \sin \theta \right\} \end{aligned}$$

7. Given, $\sin^2 2\theta + \cos^4 2\theta = \frac{3}{4}$

$$\Rightarrow (1 - \cos^2 2\theta) + \cos^4 2\theta = \frac{3}{4} \quad (\because \sin^2 x = 1 - \cos^2 x)$$

$$\Rightarrow 4 \cos^4 2\theta - 4 \cos^2 2\theta + 1 = 0$$

$$\Rightarrow (2 \cos^2 2\theta - 1)^2 = 0$$

$$\Rightarrow 2 \cos^2 2\theta - 1 = 0 \Rightarrow \cos^2 2\theta = \frac{1}{2}$$

$$\Rightarrow \cos 2\theta = \pm \frac{1}{\sqrt{2}}$$

If $\theta \in \left(0, \frac{\pi}{2}\right)$, then $2\theta \in (0, \pi)$

$$\therefore \cos 2\theta = \pm \frac{1}{\sqrt{2}} \Rightarrow 2\theta = \frac{\pi}{4}, \frac{3\pi}{4},$$

$$\left[\because \cos\left(\frac{3\pi}{4}\right) = \cos\left(\pi - \frac{\pi}{4}\right) = -\cos\frac{\pi}{4} = -\frac{1}{\sqrt{2}} \right]$$

$$\Rightarrow \theta = \frac{\pi}{8}, \frac{3\pi}{8}$$

$$\text{Sum of values of } \theta = \frac{\pi}{8} + \frac{3\pi}{8} = \frac{\pi}{2}$$

8. We have, $\sin x - \sin 2x + \sin 3x = 0$

$$\Rightarrow (\sin x + \sin 3x) - \sin 2x = 0$$

$$\Rightarrow 2 \sin\left(\frac{x+3x}{2}\right) \cos\left(\frac{x-3x}{2}\right) - \sin 2x = 0$$

$$\left[\because \sin C + \sin D = 2 \sin\left(\frac{C+D}{2}\right) \cos\left(\frac{C-D}{2}\right) \right]$$

$$\Rightarrow 2 \sin 2x \cos x - \sin 2x = 0 \quad [\because \cos(-\theta) = \cos \theta]$$

$$\Rightarrow \sin 2x(2 \cos x - 1) = 0$$

$$\Rightarrow \sin 2x = 0 \text{ or } 2 \cos x - 1 = 0$$

$$\Rightarrow 2x = 0, \pi, \dots \text{ or } \cos x = \frac{1}{2}$$

$$\Rightarrow x = 0, \frac{\pi}{2}, \dots \text{ or } x = \frac{\pi}{3}$$

In the interval $\left[0, \frac{\pi}{2}\right)$ only two values satisfy, namely

$$x = 0 \text{ and } x = \frac{\pi}{3}.$$

9. Key idea *Apply the identity*

$$\cos(x+y) \cos(x-y) = \cos^2 x - \sin^2 y$$

$$\text{and } \cos 3x = 4 \cos^3 x - 3 \cos x$$

$$\text{We have, } 8 \cos x \left(\cos\left(\frac{\pi}{6} + x\right) \cos\left(\frac{\pi}{6} - x\right) - \frac{1}{2} \right) = 1$$

$$\Rightarrow 8 \cos x \left(\cos^2 \frac{\pi}{6} - \sin^2 x - \frac{1}{2} \right) = 1$$

$$\Rightarrow 8 \cos x \left(\frac{3}{4} - \sin^2 x - \frac{1}{2} \right) = 1$$

$$\Rightarrow 8 \cos x \left(\frac{3}{4} - \frac{1}{2} - 1 + \cos^2 x \right) = 1$$

$$\Rightarrow 8 \cos x \left(\frac{-3 + 4 \cos^2 x}{4} \right) = 1$$

$$\Rightarrow 2(4 \cos^3 x - 3 \cos x) = 1$$

$$\Rightarrow 2 \cos 3x = 1 \Rightarrow \cos 3x = \frac{1}{2}$$

$$\Rightarrow 3x = \frac{\pi}{3}, \frac{5\pi}{3}, \frac{7\pi}{3} \quad [0 \leq 3x \leq 3\pi]$$

$$\Rightarrow x = \frac{\pi}{9}, \frac{5\pi}{9}, \frac{7\pi}{9}$$

$$\text{Sum} = \frac{\pi}{9} + \frac{5\pi}{9} + \frac{7\pi}{9} = \frac{13\pi}{9} \Rightarrow k\pi = \frac{13\pi}{9}$$

$$\text{Hence, } k = \frac{13}{9}$$

10. Given, $5(\tan^2 x - \cos^2 x) = 2 \cos 2x + 9$

$$\Rightarrow 5 \left(\frac{2 \sin^2 x}{2 \cos^2 x} - \cos^2 x \right) = 2 \cos 2x + 9$$

$$\Rightarrow 5 \left(\frac{1 - \cos 2x}{1 + \cos 2x} - \frac{1 + \cos 2x}{2} \right) = 2 \cos 2x + 9$$

Put $\cos 2x = y$, we have

$$5 \left(\frac{1 - y}{1 + y} - \frac{1 + y}{2} \right) = 2y + 9$$

$$\Rightarrow 5(2 - 2y - 1 - y^2 - 2y) = 2(1 + y)(2y + 9)$$

$$\Rightarrow 5(1 - 4y - y^2) = 2(2y + 9 + 2y^2 + 9y)$$

$$\Rightarrow 5 - 20y - 5y^2 = 22y + 18 + 4y^2$$

$$\Rightarrow 9y^2 + 42y + 13 = 0$$

$$\Rightarrow 9y^2 + 3y + 39y + 13 = 0$$

$$\Rightarrow 3y(3y + 1) + 13(3y + 1) = 0$$

$$\Rightarrow (3y + 1)(3y + 13) = 0$$

$$\Rightarrow y = -\frac{1}{3}, -\frac{13}{3}$$

$$\therefore \cos 2x = -\frac{1}{3}, -\frac{13}{3}$$

$$\therefore \cos 2x = -\frac{1}{3} \quad \left[\because \cos 2x \neq -\frac{13}{3} \right]$$

Now, $\cos 4x = 2 \cos^2 2x - 1$

$$= 2 \left(-\frac{1}{3} \right)^2 - 1 = \frac{2}{9} - 1 = -\frac{7}{9}$$

11. Given equation is $\cos x + \cos 2x + \cos 3x + \cos 4x = 0$

$$\Rightarrow (\cos x + \cos 3x) + (\cos 2x + \cos 4x) = 0$$

$$\Rightarrow 2 \cos 2x \cos x + 2 \cos 3x \cos x = 0$$

$$\Rightarrow 2 \cos x (\cos 2x + \cos 3x) = 0$$

$$\Rightarrow 2 \cos x \left(2 \cos \frac{5x}{2} \cos \frac{x}{2} \right) = 0$$

$$\Rightarrow \cos x \cdot \cos \frac{5x}{2} \cdot \cos \frac{x}{2} = 0$$

$$\Rightarrow \cos x = 0$$

or $\cos \frac{5x}{2} = 0$

or $\cos \frac{x}{2} = 0$

Now, $\cos x = 0$

$$\Rightarrow x = \frac{\pi}{2}, \frac{3\pi}{2} \quad [\because 0 \leq x < 2\pi]$$

$$\cos \frac{5x}{2} = 0$$

$$\Rightarrow \frac{5x}{2} = \frac{\pi}{2}, \frac{3\pi}{2}, \frac{5\pi}{2}, \frac{7\pi}{2}, \frac{9\pi}{2}, \frac{11\pi}{2}, \dots$$

$$\Rightarrow x = \frac{\pi}{5}, \frac{3\pi}{5}, \pi, \frac{7\pi}{5}, \frac{9\pi}{5} \quad [\because 0 \leq x < 2\pi]$$

and $\cos \frac{x}{2} = 0$

$$\Rightarrow \frac{x}{2} = \frac{\pi}{2}, \frac{3\pi}{2}, \frac{5\pi}{2}, \dots$$

$$\Rightarrow x = \pi \quad [\because 0 \leq x < 2\pi]$$

Hence, $x = \frac{\pi}{2}, \frac{3\pi}{2}, \pi, \frac{\pi}{5}, \frac{3\pi}{5}, \frac{7\pi}{5}, \frac{9\pi}{5}$

12. Given, $\sqrt{3} \sec x + \operatorname{cosec} x + 2(\tan x - \cot x) = 0$,

$$(-\pi < x < \pi) - \{0, \pm \pi/2\}$$

$$\Rightarrow \sqrt{3} \sin x + \cos x + 2(\sin^2 x - \cos^2 x) = 0$$

$$\Rightarrow \sqrt{3} \sin x + \cos x - 2 \cos 2x = 0$$

Multiplying and dividing by $\sqrt{a^2 + b^2}$, i.e. $\sqrt{3+1} = 2$, we get

$$2 \left(\frac{\sqrt{3}}{2} \sin x + \frac{1}{2} \cos x \right) - 2 \cos 2x = 0$$

$$\Rightarrow \left(\cos x \cdot \cos \frac{\pi}{3} + \sin x \cdot \sin \frac{\pi}{3} \right) - \cos 2x = 0$$

$$\Rightarrow \cos \left(x - \frac{\pi}{3} \right) = \cos 2x$$

$$\therefore 2x = 2n\pi \pm \left(x - \frac{\pi}{3} \right) \quad \left[\begin{array}{l} \text{since, } \cos \theta = \cos \alpha \\ \Rightarrow \theta = 2n\pi \pm \alpha \end{array} \right]$$

$$\Rightarrow 2x = 2n\pi + x - \frac{\pi}{3}$$

or $2x = 2n\pi - x + \frac{\pi}{3}$

$$\Rightarrow x = 2n\pi - \frac{\pi}{3}$$

or $3x = 2n\pi + \frac{\pi}{3}$

$$\Rightarrow x = 2n\pi - \frac{\pi}{3}$$

or $x = \frac{2n\pi}{3} + \frac{\pi}{9}$

$$\therefore x = -\frac{\pi}{3}$$

or $x = \frac{\pi}{9}, -\frac{5\pi}{9}, \frac{7\pi}{9}$

Now, sum of all distinct solutions

$$= -\frac{\pi}{3} + \frac{\pi}{9} - \frac{5\pi}{9} + \frac{7\pi}{9} = 0$$

13. $P = \{\theta : \sin \theta - \cos \theta = \sqrt{2} \cos \theta\}$

$$\Rightarrow \cos \theta (\sqrt{2} + 1) = \sin \theta$$

$$\Rightarrow \tan \theta = \sqrt{2} + 1$$

$$\Rightarrow Q = \{\theta : \sin \theta + \cos \theta = \sqrt{2} \sin \theta\}$$

$$\Rightarrow \sin \theta (\sqrt{2} - 1) = \cos \theta$$

$$\Rightarrow \tan \theta = \frac{1}{\sqrt{2} - 1} \times \frac{\sqrt{2} + 1}{\sqrt{2} + 1} = (\sqrt{2} + 1)$$

$$\therefore P = Q$$

14. Given, $\sin n\theta = \sum_{r=0}^n b_r \sin^r \theta$

Now, put $\theta = 0$, we get $0 = b_0$

$$\therefore \sin n\theta = \sum_{r=1}^n b_r \sin^r \theta$$

506 Trigonometrical Equations

$$\Rightarrow \frac{\sin n\theta}{\sin \theta} = \sum_{r=1}^n b_r (\sin \theta)^{r-1}$$

Taking limit as $\theta \rightarrow 0$

$$\Rightarrow \lim_{\theta \rightarrow 0} \frac{\sin n\theta}{\sin \theta} = \lim_{\theta \rightarrow 0} \sum_{r=1}^n b_r (\sin \theta)^{r-1}$$

$$\Rightarrow \lim_{\theta \rightarrow 0} \frac{n\theta \cdot \frac{\sin n\theta}{n\theta}}{\theta \cdot \frac{\sin \theta}{\theta}} = b_1 + 0 + 0 + 0 + \dots$$

[\because other values becomes zero for higher powers of $\sin \theta$]

$$\Rightarrow \frac{n \cdot 1}{1} = b_1 \Rightarrow b_1 = n$$

15. Given, $2 \sin^2 \theta - 3 \sin \theta - 2 = 0$

$$\Rightarrow (2 \sin \theta + 1)(\sin \theta - 2) = 0$$

$$\Rightarrow \sin \theta = -1/2$$

[neglecting $\sin \theta = 2$, as $|\sin \theta| \leq 1$]

$$\therefore \theta = n\pi + (-1)^n (7\pi/6)$$

16. Given, $3 \sin x - 4 \sin^3 x = k$, $0 < k < 1$ which can also be written as $\sin 3x = k$.

It is given that A and B are solutions of this equation. Therefore,

$$\sin 3A = k \text{ and } \sin 3B = k, \text{ where } 0 < k < 1$$

$$\Rightarrow 0 < 3A < \pi \text{ and } 0 < 3B < \pi$$

Now, $\sin 3A = k$ and $\sin 3B = k$

$$\Rightarrow \sin 3A - \sin 3B = 0$$

$$\Rightarrow 2 \cos \frac{3}{2}(A+B) \sin \frac{3}{2}(A-B) = 0$$

$$\Rightarrow \cos 3 \left(\frac{A+B}{2} \right) = 0, \sin 3 \left(\frac{A-B}{2} \right) = 0$$

But it is given that, $A > B$ and $0 < 3A < \pi$, $0 < 3B < \pi$.

Therefore, $\sin 3 \left(\frac{A-B}{2} \right) \neq 0$

Hence, $\cos 3 \left(\frac{A+B}{2} \right) = 0$

$$\Rightarrow 3 \left(\frac{A+B}{2} \right) = \frac{\pi}{2}$$

$$\Rightarrow A+B = \frac{\pi}{3}$$

$$\Rightarrow C = \pi - (A+B) = \frac{2\pi}{3}$$

17. Given, $\sin 3x + \sin x - 3 \sin 2x = \cos 3x + \cos x - 3 \cos 2x$

$$\Rightarrow 2 \sin 2x \cos x - 3 \sin 2x = 2 \cos 2x \cos x - 3 \cos 2x$$

$$\Rightarrow \sin 2x (2 \cos x - 3) = \cos 2x (2 \cos x - 3)$$

[$\because 2 \cos x - 3 \neq 0$]

$$\Rightarrow \sin 2x = \cos 2x$$

$$\Rightarrow \tan 2x = 1$$

$$\Rightarrow 2x = n\pi + \frac{\pi}{4} \Rightarrow x = \frac{n\pi}{2} + \frac{\pi}{8}$$

18. Given, $\sin x + \cos x = 1$

On dividing and multiplying each terms by $\sqrt{2}$, we get

$$\frac{1}{\sqrt{2}} \sin x + \frac{1}{\sqrt{2}} \cos x = \frac{1}{\sqrt{2}}$$

$$\Rightarrow \sin x \cos \frac{\pi}{4} = \cos x \sin \frac{\pi}{4} = \frac{1}{\sqrt{2}}$$

$$\Rightarrow \sin \left(x + \frac{\pi}{4} \right) = \sin \left(\frac{\pi}{4} \right)$$

$$\Rightarrow x + \frac{\pi}{4} = n\pi + (-1)^n \frac{\pi}{4}$$

$$\Rightarrow x = n\pi + (-1)^n \frac{\pi}{4} - \frac{\pi}{4}, n \in I$$

19. Given equation is $2 \cos^2 \left(\frac{x}{2} \right) \sin^2 x = x^2 + x^{-2}$, $x \leq \frac{\pi}{9}$

LHS = $2 \cos^2 \left(\frac{x}{2} \right) \sin^2 x < 2$ and RHS = $x^2 + \frac{1}{x^2} \geq 2$

\therefore The equation has no real solution.

20. We have, $2(\cos \beta - \cos \alpha) + \cos \alpha \cos \beta = 1$

or $4(\cos \beta - \cos \alpha) + 2 \cos \alpha \cos \beta = 2$

$$\Rightarrow 1 - \cos \alpha + \cos \beta - \cos \alpha \cos \beta$$

$$= 3 + 3 \cos \alpha - 3 \cos \beta - 3 \cos \alpha \cos \beta$$

$$\Rightarrow (1 - \cos \alpha)(1 + \cos \beta) = 3(1 + \cos \alpha)(1 - \cos \beta)$$

$$\Rightarrow \frac{(1 - \cos \alpha)}{(1 + \cos \alpha)} = \frac{3(1 - \cos \beta)}{1 + \cos \beta}$$

$$\Rightarrow \tan^2 \frac{\alpha}{2} = 3 \tan^2 \frac{\beta}{2}$$

$$\therefore \tan \frac{\alpha}{2} \pm \sqrt{3} \tan \frac{\beta}{2} = 0$$

21. Given, $\begin{vmatrix} 1 + \sin^2 \theta & \cos^2 \theta & 4 \sin 4 \theta \\ \sin^2 \theta & 1 + \cos^2 \theta & 4 \sin 4 \theta \\ \sin^2 \theta & \cos^2 \theta & 1 + 4 \sin 4 \theta \end{vmatrix} = 0$

Applying $R_3 \rightarrow R_3 - R_1$ and $R_2 \rightarrow R_2 - R_1$, we get

$$\begin{vmatrix} 1 + \sin^2 \theta & \cos^2 \theta & 4 \sin 4 \theta \\ -1 & 1 & 0 \\ -1 & 0 & 1 \end{vmatrix} = 0$$

Applying $C_1 \rightarrow C_1 + C_2$, we get

$$\begin{vmatrix} 2 & \cos^2 \theta & 4 \sin 4 \theta \\ 0 & 1 & 0 \\ -1 & 0 & 1 \end{vmatrix} = 0$$

$$\Rightarrow 2 + 4 \sin 4 \theta = 0 \Rightarrow \sin 4 \theta = \frac{-1}{2}$$

$$\Rightarrow 4 \theta = n\pi + (-1)^n \left(-\frac{\pi}{6} \right)$$

$$\Rightarrow \theta = \frac{n\pi}{4} + (-1)^{n+1} \left(\frac{\pi}{24} \right)$$

Clearly, $\theta = \frac{7\pi}{24}, \frac{11\pi}{24}$ are two values of θ lying between 0 and $\pi/2$.

22. We have, α, β are the roots of

$$\begin{aligned} \sqrt{3} a \cos x + 2b \sin x &= c \\ \therefore \sqrt{3} a \cos \alpha + 2b \sin \alpha &= c \quad \dots(i) \\ \text{and } \sqrt{3} a \cos \beta + 2b \sin \beta &= c \quad \dots(ii) \end{aligned}$$

On subtracting Eq. (ii) from Eq. (i), we get

$$\begin{aligned} \sqrt{3} a (\cos \alpha - \cos \beta) + 2b (\sin \alpha - \sin \beta) &= 0 \\ \Rightarrow \sqrt{3} a \left(-2 \sin \left(\frac{\alpha + \beta}{2} \right) \right) \sin \left(\frac{\alpha - \beta}{2} \right) \\ &+ 2b \left(2 \cos \left(\frac{\alpha + \beta}{2} \right) \right) \sin \left(\frac{\alpha - \beta}{2} \right) = 0 \end{aligned}$$

$$\Rightarrow \sqrt{3} a \sin \left(\frac{\alpha + \beta}{2} \right) = 2b \cos \left(\frac{\alpha + \beta}{2} \right)$$

$$\Rightarrow \tan \left(\frac{\alpha + \beta}{2} \right) = \frac{2b}{\sqrt{3} a}$$

$$\Rightarrow \text{MM} \quad \tan \left(\frac{\pi}{6} \right) = \frac{2b}{\sqrt{3} a} \quad \left[\because \alpha + \beta = \frac{\pi}{3}, \text{ given} \right]$$

$$\Rightarrow \frac{1}{\sqrt{3}} = \frac{2b}{\sqrt{3} a} \Rightarrow \frac{b}{a} = \frac{1}{2}$$

$$\Rightarrow \frac{b}{a} = 0.5$$

23. Here, $\frac{5}{4} \cos^2 2x + (\cos^4 x + \sin^4 x) + (\cos^6 x + \sin^6 x) = 2$

$$\begin{aligned} \Rightarrow \frac{5}{4} \cot 2x + [(\cos^2 x + \sin^2 x)^2 - 2 \sin^2 x \cos^2 x] \\ + (\cos^2 x + \sin^2 x)[(\cos^2 x + \sin^2 x)^2 - 3 \sin^2 x \cos^2 x] = 2 \\ \Rightarrow \frac{5}{4} \cos^2 2x + (1 - 2 \sin^2 x \cos^2 x) + (1 - 3 \cos^2 x \sin^2 x) = 2 \end{aligned}$$

$$\Rightarrow \frac{5}{4} \cos^2 2x - 5 \sin^2 x \cos^2 x = 0$$

$$\Rightarrow \frac{5}{4} \cos^2 2x - \frac{5}{4} \sin^2 2x = 0$$

$$\Rightarrow \frac{5}{4} \cos^2 2x - \frac{5}{4} + \frac{5}{4} \cos^2 2x = 0$$

$$\Rightarrow \frac{5}{2} \cos^2 2x = \frac{5}{4} \Rightarrow \cos^2 2x = \frac{1}{2}$$

$$\Rightarrow 2 \cos^2 2x = 1$$

$$\Rightarrow 1 + \cos 4x = 1$$

$$\Rightarrow \cos 4x = 0 \text{ as } 0 \leq x \leq 2\pi$$

$$\therefore 4x = \left\{ \frac{\pi}{2}, \frac{3\pi}{2}, \frac{5\pi}{2}, \frac{7\pi}{2}, \frac{9\pi}{2}, \frac{11\pi}{2}, \frac{13\pi}{2}, \frac{15\pi}{2} \right\}$$

$$\text{as } 0 \leq 4x \leq 8\pi$$

$$\Rightarrow x = \left\{ \frac{\pi}{8}, \frac{3\pi}{8}, \frac{5\pi}{8}, \frac{7\pi}{8}, \frac{9\pi}{8}, \frac{11\pi}{8}, \frac{13\pi}{8}, \frac{15\pi}{8} \right\}$$

Hence, the total number of solutions is 8.

24. For $Z = \{x : g(x) = 0\}, x > 0$

$$\because g(x) = \cos(2\pi \sin x) = 0$$

$$\Rightarrow 2\pi \sin x = (2n + 1) \frac{\pi}{2}, n \in \text{Integer}$$

$$\Rightarrow \sin x = \frac{2n + 1}{4}$$

$$\Rightarrow \sin x = -\frac{3}{4}, -\frac{1}{4}, \frac{1}{4}, \frac{3}{4} \quad \{\because \sin x \in [-1, 1]\}$$

here values of $\sin x, -\frac{3}{4}, -\frac{1}{4}, \frac{1}{4}, \frac{3}{4}$ are in an A.P. but corresponding values of x are not in an AP, (iii) \rightarrow R.

For $W = \{x : g'(x) = 0\}, x > 0$

$$\text{so, } g'(x) = -2\pi \cos x \sin(2\pi \sin x) = 0$$

$$\Rightarrow \text{either } \cos x = 0 \text{ or } \sin(2\pi \sin x) = 0$$

$$\Rightarrow \text{either } x = (2n + 1) \frac{\pi}{2} \text{ or } 2\pi \sin x = n\pi, n \in \text{Integers.}$$

$$\because 2\pi \sin x = n\pi$$

$$\Rightarrow \sin x = \frac{n}{2} = -1, -\frac{1}{2}, 0, \frac{1}{2}, 1 \quad \{\because \sin x \in [-1, 1]\}$$

$$\therefore x = n\pi, (2n + 1) \frac{\pi}{2} \text{ or } n\pi + (-1)^n \left(\pm \frac{\pi}{6} \right)$$

$$\Rightarrow \text{(iv)} \rightarrow \text{P, R, S}$$

Hence, option (a) is correct.

25. For, $X = \{x : f(x) = 0\}, x > 0$

$$\text{Now, } f(x) = 0$$

$$\Rightarrow \sin(\pi \cos x) = 0, x > 0$$

$$\Rightarrow \pi \cos x = n\pi, n \in \text{Integer.}$$

$$\Rightarrow \cos x = n$$

$$\Rightarrow \cos x = -1, 0, 1 \quad \{\because \cos x \in [-1, 1]\}$$

$$\Rightarrow x = n\pi \text{ or } (2n + 1) \frac{\pi}{2}, n \text{ is an integer. so, (i)} \rightarrow \text{(P), (Q)}$$

For, $Y = \{x : f'(x) = 0\}, x > 0$

$$\text{Now, } f'(x) = 0$$

$$\Rightarrow -\pi \sin x \cos(\pi \cos x) = 0$$

$$\Rightarrow \text{either } \sin x = 0 \Rightarrow x = n\pi, n \text{ is an integer, or } \cos(\pi \cos x) = 0$$

$$\Rightarrow \pi \cos x = (2n + 1) \frac{\pi}{2}, n \text{ is an integer}$$

$$\Rightarrow \cos x = \frac{2n + 1}{2}$$

$$\Rightarrow \cos x = \pm \frac{1}{2}, \quad \{\because \cos x \in [-1, 1]\}$$

$$\Rightarrow x = 2n\pi \pm \frac{\pi}{3} \text{ or } 2n\pi \pm \frac{2\pi}{3}, n \text{ is an integer.}$$

So, (ii) \rightarrow (Q), (T)

Hence, option (a) is correct.

26. Given, $\tan^2 \theta + \sec 2\theta = 1$

$$\Rightarrow \tan^2 \theta + \frac{1}{\cos 2\theta} = 1$$

$$\Rightarrow \tan^2 \theta + \frac{1 + \tan^2 \theta}{1 - \tan^2 \theta} = 1$$

$$\Rightarrow \tan^2 \theta (1 - \tan^2 \theta) + (1 + \tan^2 \theta) = 1 - \tan^2 \theta$$

$$\Rightarrow 3 \tan^2 \theta - \tan^4 \theta = 0$$

$$\Rightarrow \tan^2 \theta (3 - \tan^2 \theta) = 0$$

$$\Rightarrow \tan \theta = 0$$

$$\text{or } \tan \theta = \pm \sqrt{3}$$

Now, $\tan \theta = 0$

$$\Rightarrow \theta = m\pi, \text{ where } m \text{ is an integer.}$$

508 Trigonometrical Equations

$$\text{and} \quad \tan \theta = \pm \sqrt{3} = \tan \left(\pm \frac{\pi}{3} \right)$$

$$\Rightarrow \quad \theta = n\pi \pm \frac{\pi}{3}$$

$\therefore \theta = m\pi, n\pi \pm \frac{\pi}{3}$, where m and n are integers.

27. Given, $\sin^4 \theta - 2\sin^2 \theta + 1 = 2$

$$\Rightarrow (\sin^2 \theta - 1)^2 = 2 \Rightarrow \sin^2 \theta = \pm \sqrt{2} + 1$$

which is not possible. Hence, given statement is false.

28. $\tan(x + 100^\circ) = \tan(x + 50^\circ) \tan x \tan(x - 50^\circ)$

$$\Rightarrow \frac{\tan(x + 100^\circ)}{\tan x} = \tan(x + 50^\circ) \tan(x - 50^\circ).$$

$$\Rightarrow \frac{\sin(x + 100^\circ)}{\cos(x + 100^\circ)} \cdot \frac{\cos x}{\sin x} = \frac{\sin(x + 50^\circ) \sin(x - 50^\circ)}{\cos(x + 50^\circ) \cos(x - 50^\circ)}$$

$$\Rightarrow \frac{\sin(2x + 100^\circ) + \sin 100^\circ}{\sin(2x + 100^\circ) - \sin 100^\circ} = \frac{\cos 100^\circ - \cos 2x}{\cos 100^\circ + \cos 2x}$$

$$\Rightarrow [\sin(2x + 100^\circ) + \sin 100^\circ] [\cos 100^\circ + \cos 2x]$$

$$= [\cos 100^\circ - \cos 2x] \times [\sin(2x + 100^\circ) - \sin 100^\circ]$$

$$\Rightarrow \sin(2x + 100^\circ) \cdot \cos 100^\circ + \sin(2x + 100^\circ) \cdot \cos 2x$$

$$+ \sin 100^\circ \cos 100^\circ + \sin 100^\circ \cos 2x$$

$$= \cos 100^\circ \sin(2x + 100^\circ) - \cos 100^\circ \sin 100^\circ$$

$$- \cos 2x \sin(2x + 100^\circ) + \cos 2x \sin 100^\circ$$

$$\Rightarrow 2 \sin(2x + 100^\circ) \cos 2x + 2 \sin 100^\circ \cos 100^\circ = 0$$

$$\Rightarrow \sin(4x + 100^\circ) + \sin 100^\circ + \sin 200^\circ = 0$$

$$\Rightarrow \sin(4x + 100^\circ) + 2 \sin 150^\circ \cos 50^\circ = 0$$

$$\Rightarrow \sin(4x + 100^\circ) + 2 \cdot \frac{1}{2} \sin(90^\circ - 50^\circ) = 0$$

$$\Rightarrow \sin(4x + 100^\circ) + \sin 40^\circ = 0$$

$$\Rightarrow \sin(4x + 100^\circ) = \sin(-40^\circ)$$

$$\Rightarrow 4x + 100^\circ = n\pi + (-1)^n (-40^\circ)$$

$$\Rightarrow 4x = n(180^\circ) + (-1)^n (-40^\circ) - 100^\circ$$

$$\Rightarrow x = \frac{1}{4} [n(180^\circ) + (-1)^n (-40^\circ) - 100^\circ]$$

The smallest positive value of x is obtained

when $n = 1$.

$$\text{Therefore, } x = \frac{1}{4} (180^\circ + 40^\circ - 100^\circ)$$

$$\Rightarrow x = \frac{1}{4} (120^\circ) = 30^\circ$$

29. $\exp \{(\sin^2 x + \sin^4 x + \sin^6 x + \dots \infty) \log_e 2\}$

$$= e^{\frac{\sin^2 x}{1 - \sin^2 x} \cdot \log_e 2} = e^{\log_e 2 \cdot \frac{\sin^2 x}{\cos^2 x}}$$

$$\Rightarrow 2^{\tan^2 x} \text{ satisfies } x^2 - 9x + 8 = 0$$

$$\Rightarrow x = 1, 8$$

$$\therefore 2^{\tan^2 x} = 1 \quad \text{and} \quad 2^{\tan^2 x} = 8$$

$$\Rightarrow \tan^2 x = 0 \quad \text{and} \quad \tan^2 x = 3$$

$$\Rightarrow x = n\pi \quad \text{and} \quad \tan^2 x = \left(\tan \frac{\pi}{3} \right)^2$$

$$\Rightarrow x = n\pi \quad \text{and} \quad x = n\pi \pm \frac{\pi}{3}$$

Neglecting $x = n\pi$ as $0 < x < \frac{\pi}{2}$

$$\Rightarrow x = \frac{\pi}{3} \in \left(0, \frac{\pi}{2} \right)$$

$$\therefore \frac{\cos x}{\cos x + \sin x} = \frac{\frac{1}{2}}{\frac{1}{2} + \frac{\sqrt{3}}{2}} = \frac{1}{1 + \sqrt{3}} \times \frac{\sqrt{3} - 1}{\sqrt{3} - 1}$$

$$\Rightarrow \frac{\cos x}{\cos x + \sin x} = \frac{\sqrt{3} - 1}{2}$$

30. Since, the given system has non-trivial solution.

$$\therefore \begin{vmatrix} \sin 3\theta & -1 & 1 \\ \cos 2\theta & 4 & 3 \\ 2 & 7 & 7 \end{vmatrix} = 0$$

$$\Rightarrow \sin 3\theta (28 - 21) + 1 (7 \cos 2\theta - 6)$$

$$+ 1 (7 \cos 2\theta - 8) = 0$$

$$\Rightarrow 7 \sin 3\theta + 14 \cos 2\theta - 14 = 0$$

$$\Rightarrow \sin 3\theta + 2 \cos 2\theta - 2 = 0$$

$$\Rightarrow 3 \sin \theta - 4 \sin^3 \theta + 2 (1 - 2 \sin^2 \theta) - 2 = 0$$

$$\Rightarrow \sin \theta (4 \sin^2 \theta + 4 \sin \theta - 3) = 0$$

$$\Rightarrow \sin \theta = 0$$

$$\Rightarrow \theta = n\pi \quad \dots(i)$$

or $4 \sin^2 \theta + 4 \sin \theta - 3 = 0$

$$\Rightarrow (2 \sin \theta - 1) (2 \sin \theta + 3) = 0$$

$$\Rightarrow \sin \theta = \frac{1}{2} \quad [\because \sin \theta = -\frac{3}{2} \text{ is not possible}]$$

$$\therefore \theta = n\pi + (-1)^n \left(\frac{\pi}{6} \right) \quad \dots(ii)$$

\therefore From Eqs. (i) and (ii), we get

$$\theta = n\pi \text{ or } n\pi + (-1)^n \left(\frac{\pi}{6} \right)$$

31. Given, $2^{1 + |\cos x| + |\cos^2 x| + |\cos^3 x| + \dots} = 2^2$

$$\Rightarrow \frac{1}{2^{1 - |\cos x|}} = 2^2$$

$$\Rightarrow \frac{1}{1 - |\cos x|} = 2$$

$$\Rightarrow |\cos x| = \frac{1}{2}$$

$$\Rightarrow \cos x = \pm \frac{1}{2}$$

$$\therefore x = \frac{\pi}{3}, \frac{2\pi}{3}, -\frac{\pi}{3}, -\frac{2\pi}{3} \quad [\because x \in (-\pi, \pi)]$$

Thus, the solution set is $\left\{ \pm \frac{\pi}{3}, \pm \frac{2\pi}{3} \right\}$.

32. Given, $4 \cos^2 x \sin x - 2 \sin^2 x = 3 \sin x$

$$\Rightarrow 4(1 - \sin^2 x) \sin x - 2 \sin^2 x - 3 \sin x = 0$$

$$\Rightarrow 4 \sin x - 4 \sin^3 x - 2 \sin^2 x - 3 \sin x = 0$$

$$\Rightarrow -4 \sin^3 x - 2 \sin^2 x + \sin x = 0$$

$$\Rightarrow -\sin x (4 \sin^2 x + 2 \sin x - 1) = 0$$

$$\Rightarrow \sin x = 0 \quad \text{or} \quad 4 \sin^2 x + 2 \sin x - 1 = 0$$

$$\Rightarrow \sin x = \sin 0 \quad \text{or} \quad \sin x = \frac{-2 \pm \sqrt{4 + 16}}{2(4)}$$

$$\Rightarrow x = n\pi \quad \text{or} \quad \sin x = \frac{-1 \pm \sqrt{5}}{4}$$

$$\Rightarrow x = n\pi \quad \text{or} \quad \sin x = \sin \frac{\pi}{10}$$

$$\text{or} \quad \sin x = \sin \left(-\frac{3\pi}{10} \right)$$

$$\Rightarrow x = n\pi, n\pi + (-1)^n \frac{\pi}{10}, n\pi + (-1)^n \left(\frac{-3\pi}{10} \right)$$

\therefore General solution set is

$$\left\{ x : x = n\pi \right\} \cup \left\{ x : x = n\pi + (-1)^n \frac{\pi}{10} \right\} \\ \cup \left\{ x : x = n\pi + (-1)^n \left(\frac{-3\pi}{10} \right) \right\}$$

33. Given that,

$$2 \cos x + 2 \cos 2x + \sin 2x + \sin 3x + \sin x - 2 \sin x = 0$$

$$\therefore 2 \cos x + 2 \cos 2x + 2 \sin x \cos x + (\sin 3x - \sin x) = 0$$

$$\Rightarrow 2 \cos x + 2 \cos 2x + 2 \sin x \cos x + 2 \cos 2x \sin x = 0$$

$$\Rightarrow 2 \cos x(1 + \sin x) + 2 \cos 2x(1 + \sin x) = 0$$

$$\Rightarrow 2(1 + \sin x)(\cos x + \cos 2x) = 0$$

$$\Rightarrow 4(1 + \sin x) \cos \left(\frac{3x}{2} \right) \cos \frac{x}{2} = 0$$

$$\therefore 1 + \sin x = 0$$

$$\text{or} \quad \cos \frac{3x}{2} = 0 \quad \text{or} \quad \cos \frac{x}{2} = 0$$

$$\text{If } 1 + \sin x = 0, \text{ then } \sin x = -1$$

$$\therefore x = 2n\pi + \frac{3\pi}{2} \quad \dots(i)$$

$$\text{If } \cos \frac{3x}{2} = 0, \text{ then } \frac{3x}{2} = (2n + 1) \frac{\pi}{2}$$

$$\therefore x = (2n + 1) \frac{\pi}{3} \quad \dots(ii)$$

$$\text{And if } \cos \frac{x}{2} = 0, \text{ then } \frac{x}{2} = (2n + 1) \frac{\pi}{2}$$

$$\therefore x = (2n + 1)\pi \quad \dots(iii)$$

But given interval is $[-\pi, \pi]$.

$$\text{Put } n = -1 \text{ in Eq. (i), } x = -\frac{\pi}{2}$$

$$\text{Put } n = 0, 1, -1, -2 \text{ in Eq. (ii), } x = \frac{\pi}{3}, \pi - \frac{\pi}{3}, -\pi$$

Hence, the solution in $[-\pi, \pi]$ are $-\pi, -\frac{\pi}{2}, -\frac{\pi}{3}, \frac{\pi}{3}, \pi$.

Topic 2 Solving Equations with Graph

1. Given, $(\cot^{-1} x)^2 - 7(\cot^{-1} x) + 10 > 0$

$$\Rightarrow (\cot^{-1} x - 2)(\cot^{-1} x - 5) > 0 \quad (\text{by factorisation})$$

$$\Rightarrow \cot^{-1} x < 2 \quad \text{or} \quad \cot^{-1} x > 5$$

By wavy curve method,

$$\begin{array}{c} + \quad | \quad - \quad | \quad + \\ \hline \cot^{-1} x = 2 \quad \cot^{-1} x = 5 \end{array}$$

$$\therefore \cot^{-1} x \in (-\infty, 2) \cup (5, \infty)$$

$$\cot^{-1} x \in (0, 2) \quad [\because \text{Range of } \cot^{-1} x \text{ is } (0, \pi)]$$

$$\therefore x \in (\cot 2, \infty)$$

2. Since, $2 \sin^2 \theta - 5 \sin \theta + 2 > 0$

$$\Rightarrow (2 \sin \theta - 1)(\sin \theta - 2) > 0$$

[where, $(\sin \theta - 2) < 0, \forall \theta \in R$]

$$\therefore (2 \sin \theta - 1) < 0$$

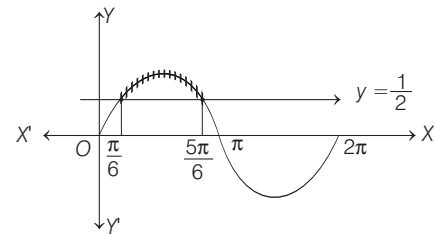

$$\Rightarrow \sin \theta < \frac{1}{2}$$

$$\therefore \text{From the graph, } \theta \in \left(0, \frac{\pi}{6} \right) \cup \left(\frac{5\pi}{6}, 2\pi \right)$$

3. (a, b, d) Given, $f(x) = \frac{\sin(\pi x)}{x^2}, x > 0$

$$\Rightarrow f'(x) = \frac{x^2 \pi \cos(\pi x) - 2x \sin(\pi x)}{x^4} \\ = \frac{2x \cos(\pi x) \left[\frac{x\pi}{2} - \tan(\pi x) \right]}{x^4} \\ = \frac{2 \cos(\pi x) \left[\frac{x\pi}{2} - \tan(\pi x) \right]}{x^3}$$

Since, for maxima and minima of $f(x)$, $f'(x) = 0$

$$\Rightarrow \cos(\pi x) = 0 \quad \text{or} \quad \tan(\pi x) = \frac{\pi x}{2}, \quad (\text{as } x > 0)$$

$$\therefore \cos(\pi x) \neq 0 \Rightarrow \tan(\pi x) = \frac{\pi x}{2}$$

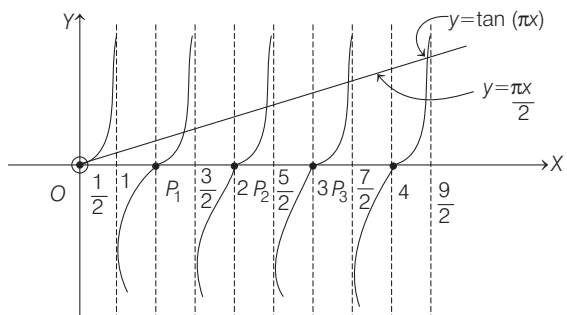

510 Trigonometrical Equations

$\therefore f'(P_1^-) < 0$ and $f'(P_1^+) > 0 \Rightarrow x = P_1 \in \left(1, \frac{3}{2}\right)$ is point of local minimum.

$\therefore f'(P_2^-) > 0$ and $f'(P_2^+) < 0 \Rightarrow x = P_2 \in \left(2, \frac{5}{2}\right)$ is point of local maximum.

From the graph, for points of maxima x_1, x_2, x_3, \dots it is clear that

$$\frac{5}{2} - x_1 > \frac{9}{2} - x_2 > \frac{13}{2} - x_3 > \frac{17}{2} - x_4 \dots$$

$$\Rightarrow x_{n+1} - x_n > 2, \forall n.$$

From the graph for points of minima y_1, y_2, y_3, \dots , it is clear that

$$\frac{3}{2} - y_1 > \frac{5}{2} - x_1 > \frac{7}{2} - y_2 > \frac{9}{2} - x_2 \dots$$

$$|x_n - y_n| > 1, \forall n \text{ and } x_1 > (y_1 + 1)$$

$$\text{And } x_1 \in \left(2, \frac{5}{2}\right), x_2 \in \left(4, \frac{9}{2}\right), x_3 \in \left(6, \frac{13}{2}\right) \dots$$

$$\Rightarrow x_n \in \left(2n, 2n + \frac{1}{2}\right), \forall n.$$

Hence, options (a), (b) and (d) are correct.

4. **PLAN** It is based on range of $\sin x$, i.e. $[-1, 1]$ and the interval for $a < x < b$.

Description of Situation As $\theta, \phi \in [0, 2\pi]$ and

$$\tan(2\pi - \theta) > 0, -1 < \sin \theta < -\frac{\sqrt{3}}{2}$$

$$\tan(2\pi - \theta) > 0$$

$$\Rightarrow -\tan \theta > 0$$

$\therefore \theta \in \text{II or IV quadrant.}$

Also, $-1 < \sin \theta < -\frac{\sqrt{3}}{2}$

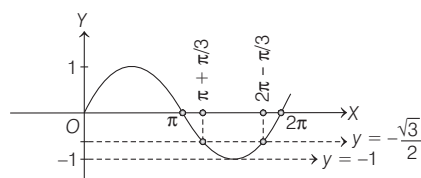

$$\Rightarrow \frac{4\pi}{3} < \theta < \frac{5\pi}{3} \text{ but } \theta \in \text{II or IV quadrant}$$

$$\Rightarrow \frac{3\pi}{2} < \theta < \frac{5\pi}{3} \dots(i)$$

$$\text{Here, } 2 \cos \theta (1 - \sin \phi) = \sin^2 \theta \left(\tan \frac{\theta}{2} + \cot \frac{\theta}{2} \right) \cos \phi - 1$$

$$\Rightarrow 2 \cos \theta - 2 \cos \theta \sin \phi = \sin^2 \theta \left(\frac{\sin^2 \frac{\theta}{2} + \cos^2 \frac{\theta}{2}}{\sin \frac{\theta}{2} \cos \frac{\theta}{2}} \right) \cos \phi - 1$$

$$\Rightarrow 2 \cos \theta - 2 \cos \theta \sin \phi = 2 \sin^2 \theta \left(\frac{1}{\sin \theta} \right) \cos \phi - 1$$

$$\Rightarrow 2 \cos \theta + 1 = 2 \sin \phi \cos \theta + 2 \sin \theta \cos \phi$$

$$\Rightarrow 2 \cos \theta + 1 = 2 \sin(\theta + \phi) \dots(ii)$$

$$\text{From Eq. (i), } \frac{3\pi}{2} < \theta < \frac{5\pi}{3}$$

$$\Rightarrow 2 \cos \theta + 1 \in (1, 2)$$

$$\therefore 1 < 2 \sin(\theta + \phi) < 2$$

$$\Rightarrow \frac{1}{2} < \sin(\theta + \phi) < 1 \dots(iii)$$

$$\Rightarrow \frac{\pi}{6} < \theta + \phi < \frac{5\pi}{6}$$

$$\text{or } \frac{13\pi}{6} < \theta + \phi < \frac{17\pi}{6}$$

$$\therefore \frac{\pi}{6} - \theta < \phi < \frac{5\pi}{6} - \theta$$

$$\text{or } \frac{13\pi}{6} - \theta < \phi < \left(\frac{17\pi}{6}\right) - \theta$$

$$\Rightarrow \phi \in \left(-\frac{3\pi}{2}, -\frac{2\pi}{3}\right) \text{ or } \left(\frac{2\pi}{3}, \frac{7\pi}{6}\right), \text{ as } \theta \in \left(\frac{3\pi}{2}, \frac{5\pi}{3}\right)$$

5. Given, $(1 - \tan \theta)(1 + \tan \theta) \sec^2 \theta + 2^{\tan^2 \theta} = 0$

$$\Rightarrow (1 - \tan^2 \theta) \cdot (1 + \tan^2 \theta) + 2^{\tan^2 \theta} = 0$$

$$\Rightarrow 1 - \tan^4 \theta + 2^{\tan^2 \theta} = 0$$

Put $\tan^2 \theta = x$

$$\therefore 1 - x^2 + 2^x = 0$$

$$\Rightarrow x^2 - 1 = 2^x$$

NOTE 2^x and $x^2 - 1$ are incompatible functions, therefore we have to consider range of both functions.

Curves $y = x^2 - 1$ and $y = 2^x$

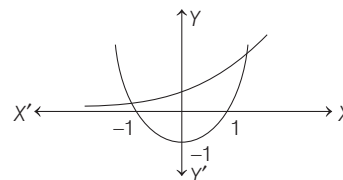

It is clear from the graph that two curves intersect at one point at $x = 3, y = 8$.

Therefore, $\tan^2 \theta = 3$

$$\Rightarrow \tan \theta = \pm \sqrt{3}$$

$$\Rightarrow \theta = \pm \frac{\pi}{3}$$

Topic 3 Problems Based on Maximum and Minimum

1. **PLAN** For solving this type of questions, obtain the LHS and RHS in equation and examine, the two are equal or not for a given interval.

Given, trigonometrical equation

$$(\sin x - \sin 3x) + 2 \sin 2x = 3$$

$$\Rightarrow -2 \cos 2x \sin x + 4 \sin x \cos x = 3$$

$$[\because \sin C - \sin D = 2 \cos\left(\frac{C+D}{2}\right) \sin\left(\frac{C-D}{2}\right) \text{ and}$$

$$\sin 2\theta = 2 \sin \theta \cos \theta]$$

$$\begin{aligned} \Rightarrow 2 \sin x (2 \cos x - \cos 2x) &= 3 \\ \Rightarrow 2 \sin x (2 \cos x - 2 \cos^2 x + 1) &= 3 \\ \Rightarrow 2 \sin x \left[\frac{3}{2} - 2 \left(\cos x - \frac{1}{2} \right)^2 \right] &= 3 \\ \Rightarrow 3 \sin x - 3 &= 4 \left(\cos x - \frac{1}{2} \right)^2 \sin x \end{aligned}$$

As $x \in (0, \pi)$ LHS ≤ 0 and RHS ≥ 0

For solution to exist, LHS = RHS = 0

Now, LHS = 0

$$\Rightarrow 3 \sin x - 3 = 0$$

$$\Rightarrow \sin x = 1$$

$$\Rightarrow x = \frac{\pi}{2}$$

For $x = \frac{\pi}{2}$,

$$\text{RHS} = 4 \left(\cos \frac{\pi}{2} - \frac{1}{2} \right)^2 \sin \frac{\pi}{2} = 4 \left(\frac{1}{4} \right) (1) = 1 \neq 0$$

\therefore No solution of the equation exists.

2. $2 \sin^2 \theta - \cos 2\theta = 0$

$$\Rightarrow \sin^2 \theta = \frac{1}{4}$$

Also, $2 \cos^2 \theta = 3 \sin \theta$

$$\therefore \sin \theta = \frac{1}{2} \quad [\because \sin \theta + 2 \neq 0]$$

\Rightarrow Two solutions exist in the interval $[0, 2\pi]$.

3. We know that,

$$-\sqrt{a^2 + b^2} \leq a \sin x + b \cos x \leq \sqrt{a^2 + b^2}$$

$$\therefore -\sqrt{74} \leq 7 \cos x + 5 \sin x \leq \sqrt{74}$$

i.e. $-\sqrt{74} \leq 2k + 1 \leq \sqrt{74}$

Since, k is integer, $-9 < 2k + 1 < 9$

$$\Rightarrow -10 < 2k < 8 \Rightarrow -5 < k < 4$$

\Rightarrow Number of possible integer values of $k = 8$.

4. Given, $3 \sin^2 x - 7 \sin x + 2 = 0$

$$\Rightarrow 3 \sin^2 x - 6 \sin x - \sin x + 2 = 0$$

$$\Rightarrow 3 \sin x (\sin x - 2) - 1 (\sin x - 2) = 0$$

$$\Rightarrow (3 \sin x - 1) (\sin x - 2) = 0$$

$$\Rightarrow \sin x = \frac{1}{3} \quad [\because \sin x = 2 \text{ is rejected}]$$

$$\Rightarrow x = n\pi + (-1)^n \sin^{-1} \frac{1}{3}, n \in I$$

For $0 \leq n \leq 5, x \in [0, 5\pi]$

There are six values of $x \in [0, 5\pi]$ which satisfy the equation $3 \sin^2 x - 7 \sin x + 2 = 0$.

5. $\tan x + \sec x = 2 \cos x, x \notin (2n+1)\frac{\pi}{2}$

$$\Rightarrow \sin x + 1 = 2 \cos^2 x$$

$$\Rightarrow \sin x + 1 = 2(1 - \sin^2 x)$$

$$\Rightarrow 2 \sin^2 x + \sin x - 1 = 0$$

$$\Rightarrow (2 \sin x - 1)(\sin x + 1) = 0$$

$$\Rightarrow \sin x = \frac{1}{2}, \sin x = -1$$

$$\Rightarrow x = \frac{\pi}{6}, \frac{5\pi}{6}$$

or $x = \frac{3\pi}{2}$

but $x \notin (2n+1)\frac{\pi}{2}$

$$\therefore x = \frac{\pi}{6}, \frac{5\pi}{6}$$

Hence, number of solutions are two.

6. Given equation is $\sin(e^x) = 5^x + 5^{-x}$ is

$$\text{LHS} = \sin(e^x) < 1, \forall x \in R$$

and $\text{RHS} = 5^x + 5^{-x} \geq 2$

$\therefore \sin(e^x) = 5^x + 5^{-x}$ has no solution.

7. Since, the given quadratic equation

$$(\cos p - 1)x^2 + (\cos p)x + \sin p = 0$$

has real roots.

\therefore Discriminant, $\cos^2 p - 4 \sin p (\cos p - 1) \geq 0$

$$\Rightarrow (\cos p - 2 \sin p)^2 - 4 \sin^2 p + 4 \sin p \geq 0$$

$$\Rightarrow (\cos p - 2 \sin p)^2 + 4 \sin p (1 - \sin p) \geq 0$$

$\therefore 4 \sin p (1 - \sin p) > 0$ for $0 < p < \pi$

and $(\cos p - 2 \sin p)^2 \geq 0$

Thus, $(\cos p - 2 \sin p)^2 + 4 \sin p (1 - \sin p) \geq 0$

for $0 < p < \pi$.

Hence, the equation has real roots for $0 < p < \pi$.

8. Let $f(x) = \tan x - x$

We know, for $0 < x < \frac{\pi}{2}$

$$\Rightarrow \tan x > x$$

$\therefore f(x) = \tan x - x$ has no root in $(0, \pi/2)$

For $\pi/2 < x < \pi$, $\tan x$ is negative.

$$\therefore f(x) = \tan x - x < 0$$

So, $f(x) = 0$ has no root in $\left(\frac{\pi}{2}, \pi\right)$.

For $\frac{3\pi}{2} < x < 2\pi$, $\tan x$ is negative.

$$\therefore f(x) = \tan x - x < 0$$

So, $f(x) = 0$ has no root in $\left(\frac{3\pi}{2}, 2\pi\right)$.

We have, $f(\pi) = 0 - \pi < 0$

and $f\left(\frac{3\pi}{2}\right) = \tan \frac{3\pi}{2} - \frac{3\pi}{2} > 0$

$\therefore f(x) = 0$ has at least one root between π and $\frac{3\pi}{2}$.

512 Trigonometrical Equations

9. Given, $a_1 + a_2 \cos 2x + a_3 \sin^2 x = 0, \forall x$

$$\Rightarrow a_1 + a_2 \cos 2x + a_3 \left(\frac{1 - \cos 2x}{2} \right) = 0, \forall x$$

$$\Rightarrow \left(a_1 + \frac{a_3}{2} \right) + \left(a_2 - \frac{a_3}{2} \right) \cos 2x = 0, \forall x$$

$$\Rightarrow a_1 + \frac{a_3}{2} = 0 \quad \text{and} \quad a_2 - \frac{a_3}{2} = 0$$

$$\Rightarrow a_1 = -\frac{k}{2}, a_2 = \frac{k}{2}, a_3 = k, \text{ where } k \in R$$

Hence, the solutions, are $\left(-\frac{k}{2}, \frac{k}{2}, k \right)$, where k is any real number.

Thus, the number of triplets is infinite.

10. We know that, $\sec^2 \theta \geq 1$

$$\Rightarrow \frac{4xy}{(x+y)^2} \geq 1$$

$$\Rightarrow 4xy \geq (x+y)^2$$

$$\Rightarrow (x+y)^2 - 4xy \leq 0$$

$$\Rightarrow (x-y)^2 \leq 0$$

$$\Rightarrow x - y = 0 \Rightarrow x = y$$

Therefore, $x + y = 2x$ [add x both sides]

But $x + y \neq 0$ since it lies in the denominator,

$$\Rightarrow 2x \neq 0 \Rightarrow x \neq 0$$

Hence, $x = y, x \neq 0$ is the answer.

Therefore, (a) and (b) are the answers.

11. For $0 < \phi < \pi/2$, we have

$$x = \sum_{n=0}^{\infty} \cos^{2n} \phi = 1 + \cos^2 \phi + \cos^4 \phi + \cos^6 \phi + \dots$$

It is clearly a GP with common ratio of $\cos^2 \phi$ which is ≤ 1 .

$$\text{Hence, } x = \frac{1}{1 - \cos^2 \phi} = \frac{1}{\sin^2 \phi} \left[\because S_{\infty} = \frac{a}{1-r}, -1 < r < 1 \right]$$

$$\text{Similarly, } y = \frac{1}{\cos^2 \phi}$$

$$\text{and } z = \frac{1}{1 - \sin^2 \phi \cos^2 \phi}$$

$$\text{Now, } x + y = \frac{1}{\sin^2 \phi} + \frac{1}{\cos^2 \phi}$$

$$= \frac{\cos^2 \phi + \sin^2 \phi}{\cos^2 \phi \sin^2 \phi} = \frac{1}{\cos^2 \phi \sin^2 \phi}$$

$$\text{Again, } \frac{1}{z} = 1 - \sin^2 \phi \cos^2 \phi = 1 - \frac{1}{xy}$$

$$\Rightarrow \frac{1}{z} = \frac{xy - 1}{xy} \Rightarrow xy = xyz - z$$

$$\Rightarrow xy + z = xyz \quad \dots(i)$$

Therefore, (b) is the answer from Eq. (i).

[putting the value of xy]

$$\Rightarrow xyz = x + y + z$$

Therefore, (c) is also the answer.

12. The given function $f : [0, 2] \rightarrow R$ defined by

$$f(x) = (3 - \sin(2\pi x)) \sin\left(\pi x - \frac{\pi}{4}\right) - \sin\left(3\pi x + \frac{\pi}{4}\right)$$

$$= (3 - \sin(2\pi x)) \left[\frac{\sin \pi x}{\sqrt{2}} - \frac{\cos \pi x}{\sqrt{2}} \right] - \left\{ \frac{\sin 3\pi x}{\sqrt{2}} + \frac{\cos(3\pi x)}{\sqrt{2}} \right\}$$

$$= (3 - \sin(2\pi x)) \frac{[\sin(\pi x) - \cos(\pi x)]}{\sqrt{2}} - \frac{1}{\sqrt{2}} [3 \sin(\pi x) - 4 \sin^3(\pi x) + 4 \cos^3(\pi x) - 3 \cos(\pi x)]$$

$$= \frac{\sin(\pi x) - \cos(\pi x)}{\sqrt{2}} [3 - \sin(2\pi x) - 3$$

$$+ 4 \{\sin^2(\pi x) + \cos^2(\pi x) + \sin(\pi x) \cos(\pi x)\}]$$

$$= \frac{\sin(\pi x) - \cos(\pi x)}{\sqrt{2}} [4 + \sin(2\pi x)]$$

As, $f(x) \geq 0 \forall x \in [\alpha, \beta]$, where $\alpha, \beta \in [0, 2]$, so

$$\sin(\pi x) - \cos(\pi x) \geq 0 \text{ as } 4 + \sin(2\pi x) > 0 \quad \forall x \in R.$$

$$\Rightarrow \pi x \in \left[\frac{\pi}{4}, \frac{5\pi}{4} \right]$$

$$\Rightarrow x \in \left[\frac{1}{4}, \frac{5}{4} \right]$$

$$\therefore \alpha = \frac{1}{4} \quad \text{and} \quad \beta = \frac{5}{4}$$

Therefore the value of $(\beta - \alpha) = 1$

13. Given, $n > 3 \in \text{Integer}$

$$\text{and } \frac{1}{\sin\left(\frac{\pi}{n}\right)} = \frac{1}{\sin\left(\frac{2\pi}{n}\right)} + \frac{1}{\sin\left(\frac{3\pi}{n}\right)}$$

$$\Rightarrow \frac{1}{\sin \frac{\pi}{n}} - \frac{1}{\sin \frac{3\pi}{n}} = \frac{1}{\sin \frac{2\pi}{n}}$$

$$\Rightarrow \frac{\sin \frac{3\pi}{n} - \sin \frac{\pi}{n}}{\sin \frac{\pi}{n} \cdot \sin \frac{3\pi}{n}} = \frac{1}{\sin \frac{2\pi}{n}}$$

$$\Rightarrow 2 \cos\left(\frac{2\pi}{n}\right) \cdot \sin \frac{\pi}{n} = \frac{\sin \frac{\pi}{n} \cdot \sin \frac{3\pi}{n}}{\sin \frac{2\pi}{n}}$$

$$\Rightarrow 2 \sin \frac{2\pi}{n} \cdot \cos \frac{2\pi}{n} = \sin \frac{3\pi}{n}$$

$$\Rightarrow \sin \frac{4\pi}{n} = \sin \frac{3\pi}{n}$$

$$\Rightarrow \frac{4\pi}{n} = \pi - \frac{3\pi}{n}$$

$$\Rightarrow \frac{7\pi}{n} = \pi \Rightarrow n = 7$$

14. Given, $\tan \theta = \cot 5\theta$

$$\Rightarrow \tan \theta = \tan \left(\frac{\pi}{2} - 5\theta \right)$$

$$\Rightarrow \frac{\pi}{2} - 5\theta = n\pi + \theta$$

$$\Rightarrow 6\theta = \frac{\pi}{2} - n\pi$$

$$\Rightarrow \theta = \frac{\pi}{12} - \frac{n\pi}{6}$$

Also, $\cos 4\theta = \sin 2\theta = \cos \left(\frac{\pi}{2} - 2\theta \right)$

$$\Rightarrow 4\theta = 2n\pi \pm \left(\frac{\pi}{2} - 2\theta \right)$$

Taking positive sign,

$$6\theta = 2n\pi + \frac{\pi}{2}$$

$$\Rightarrow \theta = \frac{n\pi}{3} + \frac{\pi}{12}$$

Taking negative sign,

$$2\theta = 2n\pi - \frac{\pi}{2} \Rightarrow \theta = n\pi - \frac{\pi}{4}$$

Above values of θ suggest that there are only 3 common solutions.

15. Given, $2 \sin^2 x - 3 \sin x + 1 \geq 0$

$$\Rightarrow 2 \sin^2 x - 2 \sin x - \sin x + 1 \geq 0$$

$$\Rightarrow (2 \sin x - 1)(\sin x - 1) \geq 0$$

$$\Rightarrow 2 \sin x - 1 \leq 0 \quad \text{or} \quad \sin x \geq 1$$

$$\Rightarrow \sin x \leq \frac{1}{2} \quad \text{or} \quad \sin x = 1$$

$$\Rightarrow x \in \left[0, \frac{\pi}{6} \right] \cup \left\{ \frac{\pi}{2} \right\} \cup \left[\frac{5\pi}{6}, \pi \right]$$

16. Given, $x + y = \frac{2\pi}{3}$

and $\cos x + \cos y = \frac{3}{2}$

$$\Rightarrow \cos x + \cos \left(\frac{2\pi}{3} - x \right) = \frac{3}{2}$$

$$\Rightarrow \cos x + \left(-\frac{1}{2} \cos x + \frac{\sqrt{3}}{2} \sin x \right) = \frac{3}{2}$$

$$\Rightarrow \frac{1}{2} \cos x + \frac{\sqrt{3}}{2} \sin x = \frac{3}{2}$$

$$\Rightarrow \sin \left(\frac{\pi}{6} + x \right) = \frac{3}{2}, \text{ which is never possible.}$$

Hence, no solution exists.

17. Since, $\cos \theta \leq 1 \Rightarrow \log(\cos \theta) < 0$

and $\cos(\log \theta) > 0$

$$\therefore \cos(\log \theta) > \log(\cos \theta)$$

18. Given, $\cos(p \sin x) = \sin(p \cos x), \forall x \in [0, 2\pi]$

$$\Rightarrow \cos(p \sin x) = \cos \left(\frac{\pi}{2} - p \cos x \right)$$

$$\Rightarrow p \sin x = 2n\pi \pm \left(\frac{\pi}{2} - p \cos x \right), n \in I$$

$$[\because \cos \theta = \cos \alpha \Rightarrow \theta = 2n\pi \pm \alpha, n \in I]$$

$$\Rightarrow p \sin x + p \cos x = 2n\pi + \pi/2$$

or $p \sin x - p \cos x = 2n\pi - \pi/2, n \in I$

$$\Rightarrow p(\sin x + \cos x) = 2n\pi + \pi/2$$

or $p(\sin x - \cos x) = 2n\pi - \pi/2, n \in I$

$$\Rightarrow p\sqrt{2} \left(\cos \frac{\pi}{4} \sin x + \sin \frac{\pi}{4} \cos x \right) = 2n\pi + \frac{\pi}{2}$$

or $p\sqrt{2} \left(\cos \frac{\pi}{4} \sin x - \sin \frac{\pi}{4} \cos x \right) = 2n\pi - \frac{\pi}{2}, n \in I$

$$\Rightarrow p\sqrt{2} [\sin(x + \pi/4)] = \frac{(4n+1)\pi}{2}$$

or $p\sqrt{2} [\sin(x - \pi/4)] = (4n-1)\frac{\pi}{2}, n \in I$

Now,

$$-1 \leq \sin(x \pm \pi/4) \leq 1$$

$$\Rightarrow -p\sqrt{2} \leq p\sqrt{2} \sin(x \pm \pi/4) \leq p\sqrt{2}$$

$$\Rightarrow -p\sqrt{2} \leq \frac{(4n+1)\pi}{2} \leq p\sqrt{2}, n \in I$$

or $-p\sqrt{2} \leq \frac{(4n-1)\pi}{2} \leq p\sqrt{2}, n \in I$

Second inequality is always a subset of first, therefore we have to consider only first.

It is sufficient to consider $n \geq 0$, because for $n > 0$, the solution will be same for $n \geq 0$.

If $n \geq 0$, $-\sqrt{2}p \leq (4n+1)\pi/2$

$$\Rightarrow (4n+1)\pi/2 \leq \sqrt{2}p$$

For p to be least, n should be least.

$$\Rightarrow n = 0$$

$$\Rightarrow \sqrt{2}p \geq \pi/2 \Rightarrow p \geq \frac{\pi}{2\sqrt{2}}$$

Therefore, least value of $p = \frac{\pi}{2\sqrt{2}}$

19. Given, $e^{\sin x} - \frac{1}{e^{\sin x}} = 4$

$$\Rightarrow (e^{\sin x})^2 - 4(e^{\sin x}) - 1 = 0$$

$$\Rightarrow e^{\sin x} = \frac{4 \pm \sqrt{16+4}}{2} = 2 \pm \sqrt{5}$$

But since, $e \sim 2.72$ and we know, $0 < e^{\sin x} < e$

$\therefore e^{\sin x} = 2 \pm \sqrt{5}$ is not possible.

Hence, it does not exist any solution.

20. The point of intersection is given by

$$\sin 3x = \cos x = \sin \left(\frac{\pi}{2} - x \right)$$

$$\Rightarrow 3x = n\pi + (-1)^n \left(\frac{\pi}{2} - x \right)$$

514 Trigonometrical Equations

(i) Let n be even i.e. $n = 2m$

$$\Rightarrow 3x = 2m\pi + \frac{\pi}{2} - x$$

$$\Rightarrow n = \frac{m\pi}{2} + \frac{\pi}{8} \quad \dots(i)$$

(ii) Let n be odd i.e. $n = (2m + 1)$

$$\therefore 3x = (2m + 1)\pi - \left(\frac{\pi}{2} - x\right)$$

$$\Rightarrow 3x = 2m\pi + \frac{\pi}{2} + x$$

$$\Rightarrow x = m\pi + \frac{\pi}{4} \quad \dots(ii)$$

Now, $-\frac{\pi}{2} \leq x \leq \frac{\pi}{2}$

$$\Rightarrow x = \frac{\pi}{8}, \frac{\pi}{4} - \frac{3\pi}{8} \quad [\text{from Eqs. (i) and (ii)}]$$

Thus, points of intersection are

$$\left(\frac{\pi}{8}, \cos \frac{\pi}{8}\right) \left(\frac{\pi}{4}, \cos \frac{\pi}{4}\right) \left(-\frac{3\pi}{8}, \cos \frac{3\pi}{8}\right)$$

21. We have, $\cos \theta + \sin \theta = \sqrt{2} \left(\frac{1}{\sqrt{2}} \cos \theta + \frac{1}{\sqrt{2}} \sin \theta \right)$

$$= \sqrt{2} \left(\sin \frac{\pi}{4} \cdot \cos \theta + \cos \frac{\pi}{4} \cdot \sin \theta \right)$$

$$= \sqrt{2} \sin \left(\frac{\pi}{4} + \theta \right)$$

$$\Rightarrow \cos \theta + \sin \theta \leq \sqrt{2} < \frac{\pi}{2}$$

$$\left[\text{as, } \sqrt{2} = 1.4141, \frac{\pi}{2} = 1.57 \text{ (approx)} \right]$$

$$\Rightarrow \cos \theta + \sin \theta < \frac{\pi}{2}$$

Since, $\cos \theta < \frac{\pi}{2} - \sin \theta$

$$\Rightarrow \sin(\cos \theta) < \sin \left(\frac{\pi}{2} - \sin \theta \right)$$

$$\Rightarrow \sin(\cos \theta) < \cos(\sin \theta)$$

$$\Rightarrow \cos(\sin \theta) > \sin(\cos \theta)$$

22. Let $f(\theta) = 5 \cos \theta + 3 \cos \left(\theta + \frac{\pi}{3} \right) + 3$

$$= 5 \cos \theta + 3 \left(\cos \theta \cos \frac{\pi}{3} - \sin \theta \sin \frac{\pi}{3} \right) + 3$$

$$= 5 \cos \theta + 3 \left(\frac{1}{2} \right) \cos \theta - 3 \left(\frac{\sqrt{3}}{2} \right) \sin \theta + 3$$

$$= \frac{13}{2} \cos \theta - \frac{3\sqrt{3}}{2} \sin \theta + 3$$

$$\Rightarrow f(\theta) = \frac{1}{2} (13 \cos \theta - 3\sqrt{3} \sin \theta) + 3$$

Put $r \cos \alpha = 13$, $r \sin \alpha = 3\sqrt{3}$, then

$$r = \sqrt{169 + 27} = \sqrt{196} = 14$$

$$\therefore f(\theta) = \frac{1}{2} (r \cos \alpha \cos \theta - r \sin \alpha \sin \theta) + 3$$

$$= \frac{1}{2} r \cos(\theta + \alpha) + 3$$

$$= 7 \cos(\theta + \alpha) + 3$$

Now, $-1 \leq \cos(\theta + \alpha) \leq 1$

$$\Rightarrow -7 \leq 7 \cos(\theta + \alpha) \leq 7$$

$$\Rightarrow -4 \leq f(\theta) \leq 10$$

22

Inverse Circular Functions

Topic 1 Domain and Range

Objective Question I (Only one correct option)

1. The domain of the function

$$f(x) = \sin^{-1}\left(\frac{|x|+5}{x^2+1}\right)$$

is $(-\infty, -a] \cup [a, \infty)$. Then a is equal to

- (a) $\frac{\sqrt{17}}{2} + 1$ (b) $\frac{\sqrt{17}-1}{2}$
(c) $\frac{1+\sqrt{17}}{2}$ (d) $\frac{\sqrt{17}}{2}$

(2020 Main, 2 Sep I)

2. The number of real solutions of

$$\tan^{-1}\sqrt{x(x+1)} + \sin^{-1}\sqrt{x^2+x+1} = \frac{\pi}{2}$$
 is (1999, 2M)

- (a) zero (b) one
(c) two (d) infinite

Fill in the Blank

3. The greater of the two angles $A = 2 \tan^{-1}(2\sqrt{2}-1)$ and $B = 3 \sin^{-1}\left(\frac{1}{3}\right) + \sin^{-1}\left(\frac{3}{5}\right)$ is (1989, 2M)

Topic 2 Properties of Inverse Functions

Objective Question I (Only one correct option)

1. $2\pi - \left(\sin^{-1}\frac{4}{5} + \sin^{-1}\frac{5}{13} + \sin^{-1}\frac{16}{65}\right)$ is equal to

- (a) $\frac{\pi}{2}$ (b) $\frac{5\pi}{4}$ (c) $\frac{3\pi}{2}$ (d) $\frac{7\pi}{4}$

(2020 Main, 3 Sep I)

- (a) If $\alpha = \tan(\cos^{-1} f(6))$, then $\alpha^2 + 2\alpha - 1 = 0$

(b) $f(4) = \frac{\sqrt{3}}{2}$

(c) $\sin(7 \cos^{-1} f(5)) = 0$

(d) $\lim_{n \rightarrow \infty} f(n) = \frac{1}{2}$

Objective Questions II

(One or more than one correct option)

2. For non-negative integers n , let

$$f(n) = \frac{\sum_{k=0}^n \sin\left(\frac{k+1}{n+2}\pi\right) \sin\left(\frac{k+2}{n+2}\pi\right)}{\sum_{k=0}^n \sin^2\left(\frac{k+1}{n+2}\pi\right)}$$

Assuming $\cos^{-1} x$ takes values in $[0, \pi]$, which of the following options is/are correct? (2019 Adv.)

3. Let $f(x) = \log_e(\sin x)$, $(0 < x < \pi)$ and $g(x) = \sin^{-1}(e^{-x})$, $(x \geq 0)$. If α is a positive real number such that $a = (f \circ g)'(\alpha)$ and $b = (f \circ g)(\alpha)$, then (2019 Main, 10 April II)
- (a) $\alpha\alpha^2 - b\alpha - a = 0$ (b) $\alpha\alpha^2 - b\alpha - a = 1$
(c) $\alpha\alpha^2 + b\alpha - a = -2\alpha^2$ (d) $\alpha\alpha^2 + b\alpha + a = 0$

4. The value of $\cot\left(\sum_{n=1}^{19} \cot^{-1}\left(1 + \sum_{p=1}^n 2p\right)\right)$ is

- (a) $\frac{23}{22}$
(c) $\frac{19}{21}$

- (b) $\frac{21}{19}$
(d) $\frac{22}{23}$

(2019 Main, 10 Jan II)

516 Inverse Circular Functions

5. If $\cos^{-1}\left(\frac{2}{3x}\right) + \cos^{-1}\left(\frac{3}{4x}\right) = \frac{\pi}{2}$ ($x > \frac{3}{4}$), then x is equal to

- (a) $\frac{\sqrt{145}}{10}$ (b) $\frac{\sqrt{146}}{12}$ (c) $\frac{\sqrt{145}}{12}$ (d) $\frac{\sqrt{145}}{11}$ (2019 Main, 9 Jan I)

6. If $\alpha = 3\sin^{-1}\left(\frac{6}{11}\right)$ and $\beta = 3\cos^{-1}\left(\frac{4}{9}\right)$, where the inverse trigonometric functions take only the principal values, then the correct option(s) is/are (2015 Adv.)

- (a) $\cos \beta > 0$ (b) $\sin \beta < 0$
 (c) $\cos(\alpha + \beta) > 0$ (d) $\cos \alpha < 0$

7. If $0 < x < 1$, then $\sqrt{1+x^2} [\{x \cos(\cot^{-1} x) + \sin(\cot^{-1} x)\}^2 - 1]^{1/2}$ is equal to (2008, 3M)

- (a) $\frac{x}{\sqrt{1+x^2}}$ (b) x (c) $x\sqrt{1+x^2}$ (d) $\sqrt{1+x^2}$

8. The value of x for which $\sin[\cot^{-1}(1+x)] = \cos(\tan^{-1} x)$ is (2004, 1M)

- (a) $\frac{1}{2}$ (b) 1 (c) 0 (d) $-\frac{1}{2}$

9. If $\sin^{-1}\left(x - \frac{x^2}{2} + \frac{x^3}{4} - \dots\right) + \cos^{-1}\left(x^2 - \frac{x^4}{2} + \frac{x^6}{4} - \dots\right) = \frac{\pi}{2}$, for $0 < |x| < \sqrt{2}$, then x equals (2001, 1M)

- (a) $1/2$ (b) 1 (c) $-1/2$ (d) -1

10. The principal value of $\sin^{-1}\left(\sin \frac{2\pi}{3}\right)$ is (1986, 2M)

- (a) $-\frac{2\pi}{3}$ (b) $\frac{2\pi}{3}$ (c) $\frac{\pi}{3}$ (d) $\frac{5\pi}{3}$

Match the Columns

11. Match List I with List II and select the correct answer using the code given below the lists.

List I	List II
P. $\left[\frac{1}{y^2} \left\{ \cos(\tan^{-1} y) + y \sin(\tan^{-1} y) \right\}^2 + y^4 \right]^{1/2}$ takes value	1. $\frac{1}{2} \sqrt{\frac{5}{3}}$
Q. If $\cos x + \cos y + \cos z = 0 = \sin x + \sin y + \sin z$, then possible value of $\cos \frac{x-y}{2}$ is	2. $\sqrt{2}$
R. If $\cos\left(\frac{\pi}{4} - x\right) \cos 2x + \sin x \sin 2x \sec x = \cos x \sin 2x \sec x + \cos\left(\frac{\pi}{4} + x\right) \cos 2x$, then possible value of $\sec x$ is	3. $\frac{1}{2}$
S. If $\cot(\sin^{-1} \sqrt{1-x^2}) = \sin[\tan^{-1}(x\sqrt{6})]$, $x = 0$. Then, possible value of x is	4. 1

Codes

	P	Q	R	S
(a)	4	3	1	2
(b)	4	3	2	1
(c)	3	4	2	1
(d)	3	4	1	2

12. Let (x, y) be such that $\sin^{-1}(ax) + \cos^{-1}(y) + \cos^{-1}(bxy) = \frac{\pi}{2}$. (2007)

Column I	Column II
A. If $a = 1$ and $b = 0$, then (x, y)	p. lies on the circle $x^2 + y^2 = 1$
B. If $a = 1$ and $b = 1$, then (x, y)	q. lies on $(x^2 - 1)(y^2 - 1) = 0$
C. If $a = 1$ and $b = 2$, then (x, y)	r. lies on $y = x$
D. If $a = 2$ and $b = 2$, then (x, y)	s. lies on $(4x^2 - 1)(y^2 - 1) = 0$

13. Let $E_1 = \{x \in R : x \neq 1 \text{ and } \frac{x}{x-1} > 0\}$ and

$$E_2 = \left\{ x \in E_1 : \sin^{-1} \left(\log_e \left(\frac{x}{x-1} \right) \right) \text{ is a real number} \right\}$$

(Here, the inverse trigonometric function $\sin^{-1} x$ assumes values in $\left[-\frac{\pi}{2}, \frac{\pi}{2}\right]$). Let $f: E_1 \rightarrow R$ be the

function defined by $f(x) = \log_e \left(\frac{x}{x-1} \right)$ and $g: E_2 \rightarrow R$ be

the function defined by $g(x) = \sin^{-1} \left(\log_e \left(\frac{x}{x-1} \right) \right)$.

(2018 Adv.)

List I	List II
P. The range of f is	1. $\left(-\infty, \frac{1}{1-e}\right] \cup \left[\frac{e}{e-1}, \infty\right)$
Q. The range of g contains	2. $(0, 1)$
R. The domain of f contains	3. $\left[-\frac{1}{2}, \frac{1}{2}\right]$
S. The domain of g is	4. $(-\infty, 0) \cup (0, \infty)$
	5. $\left(-\infty, \frac{e}{e-1}\right]$
	6. $(-\infty, 0) \cup \left(\frac{1}{2}, \frac{e}{e-1}\right]$

The correct option is

- (a) $P \rightarrow 4; Q \rightarrow 2; R \rightarrow 1; S \rightarrow 1$
 (b) $P \rightarrow 3; Q \rightarrow 3; R \rightarrow 6; S \rightarrow 5$
 (c) $P \rightarrow 4; Q \rightarrow 2; R \rightarrow 1; S \rightarrow 6$
 (d) $P \rightarrow 4; Q \rightarrow 3; R \rightarrow 6; S \rightarrow 5$

Integer & Numerical Answer Type Questions

14. The value of

$$\sec^{-1} \left(\frac{1}{4} \sum_{k=0}^{10} \sec \left(\frac{7\pi}{12} + \frac{k\pi}{2} \right) \sec \left(\frac{7\pi}{12} + \frac{(k+1)\pi}{2} \right) \right)$$

in the interval $\left[-\frac{\pi}{4}, \frac{3\pi}{4}\right]$ equals

(2019 Adv.)

15. The number of real solutions of the equation $\sin^{-1}\left(\sum_{i=1}^{\infty} x^{i+1} - x \sum_{i=1}^{\infty} \left(\frac{x}{2}\right)^i\right) = \frac{\pi}{2} - \cos^{-1}\left(\sum_{i=1}^{\infty} \left(-\frac{x}{2}\right)^i - \sum_{i=1}^{\infty} (-x)^i\right)$ lying in the interval $\left(-\frac{1}{2}, \frac{1}{2}\right)$ is

(Here, the inverse trigonometric functions $\sin^{-1} x$ and $\cos^{-1} x$ assume values in $\left[-\frac{\pi}{2}, \frac{\pi}{2}\right]$ and $[0, \pi]$, respectively.) (2018 Adv.)

16. If $f: [0, 4\pi] \rightarrow [0, \pi]$ be defined by $f(x) = \cos^{-1}(\cos x)$. Then, the number of points $x \in [0, 4\pi]$ satisfying the equation $f(x) = \frac{10-x}{10}$, is (2014 Adv.)

Analytical & Descriptive Questions

17. Prove that $\cos \tan^{-1} [\sin (\cot^{-1} x)] = \sqrt{\frac{x^2+1}{x^2+2}}$. (2002, 5M)
18. Find the value of $\cos (2 \cos^{-1} x + \sin^{-1} x)$ at $x = \frac{1}{5}$, where $0 \leq \cos^{-1} x \leq \pi$ and $-\pi/2 \leq \sin^{-1} x \leq \pi/2$. (1981, 2M)

Topic 3 Sum and Difference Formulae

Objective Questions I (Only one correct option)

1. The value of $\sin^{-1}\left(\frac{12}{13}\right) - \sin^{-1}\left(\frac{3}{5}\right)$ is equal to (2019 Main, 12 April I)
- (a) $\pi - \sin^{-1}\left(\frac{63}{65}\right)$
 (b) $\frac{\pi}{2} - \sin^{-1}\left(\frac{56}{65}\right)$
 (c) $\frac{\pi}{2} - \cos^{-1}\left(\frac{9}{65}\right)$
 (d) $\pi - \cos^{-1}\left(\frac{33}{65}\right)$
2. If $\cos^{-1} x - \cos^{-1} \frac{y}{2} = \alpha$, where $-1 \leq x \leq 1, -2 \leq y \leq 2, x \leq \frac{y}{2}$, then for all $x, y, 4x^2 - 4xy \cos \alpha + y^2$ is equal to (2019 Main, 10 April II)
- (a) $2 \sin^2 \alpha$
 (b) $4 \cos^2 \alpha + 2x^2 y^2$
 (c) $4 \sin^2 \alpha$
 (d) $4 \sin^2 \alpha - 2x^2 y^2$
3. If $\alpha = \cos^{-1}\left(\frac{3}{5}\right), \beta = \tan^{-1}\left(\frac{1}{3}\right)$, where $0 < \alpha, \beta < \frac{\pi}{2}$, then $\alpha - \beta$ is equal to (2019 Main, 8 April I)
- (a) $\tan^{-1}\left(\frac{9}{5\sqrt{10}}\right)$ (b) $\cos^{-1}\left(\frac{9}{5\sqrt{10}}\right)$
 (c) $\tan^{-1}\left(\frac{9}{14}\right)$ (d) $\sin^{-1}\left(\frac{9}{5\sqrt{10}}\right)$
4. Considering only the principal values of inverse functions, the set $A = \left\{x \geq 0: \tan^{-1}(2x) + \tan^{-1}(3x) = \frac{\pi}{4}\right\}$ (2019 Main, 12 Jan I)
- (a) is an empty set
 (b) is a singleton
 (c) contains more than two elements
 (d) contains two elements
5. If $x = \sin^{-1}(\sin 10)$ and $y = \cos^{-1}(\cos 10)$, then $y - x$ is equal to (2019 Main, 9 Jan II)
- (a) 0 (b) 10 (c) 7π (d) π

6. If $\tan^{-1} y = \tan^{-1} x + \tan^{-1}\left(\frac{2x}{1-x^2}\right)$, where $|x| < \frac{1}{\sqrt{3}}$. Then, the value of y is
- (a) $\frac{3x-x^3}{1-3x^2}$ (b) $\frac{3x+x^2}{1-3x^2}$
 (c) $\frac{3x-x^3}{1+3x^2}$ (d) $\frac{3x+x^3}{1+3x^2}$
7. The value of $\cot \left\{ \sum_{n=1}^{23} \cot^{-1} \left(1 + \sum_{k=1}^n 2k \right) \right\}$ is (2013 Main)
- (a) $\frac{23}{25}$ (b) $\frac{25}{23}$ (c) $\frac{23}{24}$ (d) $\frac{24}{23}$
8. If x, y and z are in AP and $\tan^{-1} x, \tan^{-1} y$ and $\tan^{-1} z$ are also in AP, then (2013 Main)
- (a) $x = y = z$ (b) $2x = 3y = 6z$
 (c) $6x = 3y = 2z$ (d) $6x = 4y = 3z$

9. The value of $\tan \left[\cos^{-1}\left(\frac{4}{5}\right) + \tan^{-1}\left(\frac{2}{3}\right) \right]$ is (1983, 1M)
- (a) $\frac{6}{17}$ (b) $\frac{17}{6}$
 (c) $\frac{16}{7}$ (d) None of these

Fill in the Blanks

10. The numerical value of $\tan \left[2 \tan^{-1}\left(\frac{1}{5}\right) - \frac{\pi}{4} \right]$ is ... (1984, 2M)
11. If a, b, c are positive real numbers
- $$\theta = \tan^{-1} \sqrt{\frac{a(a+b+c)}{bc}} + \tan^{-1} \sqrt{\frac{b(a+b+c)}{ca}} + \tan^{-1} \sqrt{\frac{c(a+b+c)}{ab}}$$
- Then, $\tan \theta$ equals (1981, 2M)
12. Solve the following equation for x . (1978, 3M)
- $$\tan^{-1} 2x + \tan^{-1} 3x = \frac{\pi}{4}$$

Answers

Topic 1

1. (c) 2. (c) 3. A

Topic 2

1. (c) 2. (a,b,c) 3. (b) 4. (b)
 5. (c) 6. (c) 7. (c) 8. (d)
 9. (b) 10. (c) 11. (b)
 12. $(A \rightarrow p; B \rightarrow q; C \rightarrow p; D \rightarrow s)$ 13. (a)

14. (0)

15. (2)

16. (3)

18. $-\frac{2\sqrt{6}}{6}$

Topic 3

1. (b) 2. (c) 3. (d) 4. (b)
 5. (d) 6. (a) 7. (b) 8. (a)
 9. (b) 10. $\left(-\frac{7}{17}\right)$ 11. 0 12. $\frac{1}{6}$

Hints & Solutions

Topic 1 Domain and Range

1. Given function, $f(x) = \sin^{-1}\left(\frac{|x|+5}{x^2+1}\right)$

For, domain of 'f'

$$\frac{|x|+5}{x^2+1} \leq 1, \text{ as } \frac{|x|+5}{x^2+1} > 0 \forall x \in R$$

$$\Rightarrow |x|+5 \leq x^2+1 \text{ as } x^2+1 \text{ is positive } \forall x \in R$$

$$\Rightarrow x^2 - |x| - 4 \geq 0$$

$$\Rightarrow |x|^2 - |x| - 4 \geq 0 \quad [\because \forall x \in R, x^2 = |x|^2] \quad \dots(i)$$

$$\therefore \text{For } |x|^2 - |x| - 4 = 0$$

$$\Rightarrow |x| = \frac{1 \pm \sqrt{1+16}}{2}$$

$$\Rightarrow |x| = \frac{1 \pm \sqrt{17}}{2} \Rightarrow |x| = \frac{1 + \sqrt{17}}{2} \text{ as } |x| \geq 0$$

$$\therefore |x| \geq \frac{\sqrt{17}+1}{2}$$

$$\Rightarrow x \in \left(-\infty, -\frac{\sqrt{17}+1}{2}\right] \cup \left[\frac{\sqrt{17}+1}{2}, \infty\right)$$

$$\therefore a = \frac{\sqrt{17}+1}{2}$$

2. Given function is

$$\tan^{-1} \sqrt{x(x+1)} + \sin^{-1} \sqrt{x^2+x+1} = \frac{\pi}{2}$$

Function is defined, if

(i) $x(x+1) \geq 0$, since domain of square root function.

(ii) $x^2+x+1 \geq 0$, since domain of square root function.

(iii) $\sqrt{x^2+x+1} \leq 1$, since domain of \sin^{-1} function.

From (ii) and (iii), $0 \leq x^2+x+1 \leq 1 \cap x^2+x \geq 0$

$$\Rightarrow 0 \leq x^2+x+1 \leq 1 \cap x^2+x+1 \geq 1$$

$$\Rightarrow x^2+x+1 = 1$$

$$\Rightarrow x^2+x = 0$$

$$\Rightarrow x(x+1) = 0$$

$$\Rightarrow x = 0, x = -1$$

3. Given, $A = 2 \tan^{-1}(2\sqrt{2}-1)$

$$\text{and } B = 3 \sin^{-1}\left(\frac{1}{3}\right) + \sin^{-1}\left(\frac{3}{5}\right)$$

$$\text{Here, } A = 2 \tan^{-1}(2\sqrt{2}-1)$$

$$= 2 \tan^{-1}(2 \times 1.414 - 1) = 2 \tan^{-1}(1.828)$$

$$\therefore A > 2 \tan^{-1}(\sqrt{3}) = 2 \cdot \frac{\pi}{3} = \frac{2\pi}{3}$$

To find the value of B, we first say

$$\sin^{-1}\frac{1}{3} < \sin^{-1}\frac{1}{2} = \frac{\pi}{6}$$

$$\text{so that } 0 < 3 \sin^{-1}\frac{1}{3} < \frac{\pi}{2}$$

$$\text{Now, } 3 \sin^{-1}\frac{1}{3} = \sin^{-1}\left(3 \cdot \frac{1}{3} - 4 \cdot \frac{1}{27}\right) = \sin^{-1}\left(\frac{23}{27}\right)$$

$$= \sin^{-1}(0.851) < \sin^{-1}\left(\frac{\sqrt{3}}{2}\right) = \frac{\pi}{3}$$

$$\sin^{-1}\left(\frac{3}{5}\right) = \sin^{-1}(0.6) < \sin^{-1}\left(\frac{\sqrt{3}}{2}\right) = \frac{\pi}{3}$$

$$\therefore B < \frac{\pi}{3} + \frac{\pi}{3} = \frac{2\pi}{3}$$

$$\text{Thus, } A > \frac{2\pi}{3} \text{ and } B < \frac{2\pi}{3}$$

Hence, greater angle is A.

Topic 2 Properties of Inverse Functions

1. We have,

$$2\pi - \left(\sin^{-1}\frac{4}{5} + \sin^{-1}\frac{5}{13} + \sin^{-1}\frac{16}{65}\right)$$

$$= 2\pi - \left(\tan^{-1}\frac{4}{3} + \tan^{-1}\frac{5}{12} + \tan^{-1}\frac{16}{63}\right)$$

$$= 2\pi - \left(\tan^{-1}\frac{\frac{4}{3} + \frac{5}{12}}{1 - \frac{5}{9}} + \tan^{-1}\frac{16}{63}\right)$$

$$\begin{aligned}
 &= 2\pi - \left(\tan^{-1} \left(\frac{21 \times 3}{4 \times 4} \right) + \tan^{-1} \frac{16}{63} \right) \\
 &= 2\pi - \left(\tan^{-1} \frac{63}{16} + \tan^{-1} \frac{16}{63} \right) \\
 &= 2\pi - \left(\cot^{-1} \frac{16}{63} + \tan^{-1} \frac{16}{63} \right) \\
 &= 2\pi - \frac{\pi}{2} = \frac{3\pi}{2}
 \end{aligned}$$

Hence, option (c) is correct.

2. It is given, that for non-negative integers 'n',

$$\begin{aligned}
 f(n) &= \frac{\sum_{k=0}^n \sin \left(\frac{k+1}{n+2} \pi \right) \sin \left(\frac{k+2}{n+2} \pi \right)}{\sum_{k=0}^n \sin^2 \left(\frac{k+1}{n+2} \pi \right)} \\
 &= \frac{\sum_{k=0}^n \left(\cos \frac{\pi}{n+2} - \cos \left(\frac{2k+3}{n+2} \pi \right) \right)}{\sum_{k=0}^n \left(1 - \cos \left(\frac{2k+2}{n+2} \pi \right) \right)}
 \end{aligned}$$

[∵ $2 \sin A \sin B = \cos(A - B) - \cos(A + B)$ and $2 \sin^2 A = 1 - \cos 2A$]

$$\begin{aligned}
 &\left\{ \cos \left(\frac{\pi}{n+2} \right) - \left[\cos \frac{3\pi}{n+2} + \cos \frac{5\pi}{n+2} + \cos \frac{7\pi}{n+2} \right. \right. \\
 &\quad \left. \left. + \dots + \cos \left(\frac{2n+3}{n+2} \pi \right) \right] \right\} \\
 &= \frac{\sum_{k=0}^n 1 - \left\{ \cos \frac{2\pi}{n+2} + \cos \frac{4\pi}{n+2} + \cos \frac{6\pi}{n+2} + \dots + \cos \left(\frac{2n+2}{n+2} \pi \right) \right\}}{\sum_{k=0}^n 1 - \left\{ \cos \frac{2\pi}{n+2} + \cos \frac{4\pi}{n+2} + \cos \frac{6\pi}{n+2} + \dots + \cos \left(\frac{2n+2}{n+2} \pi \right) \right\}}
 \end{aligned}$$

$$\begin{aligned}
 &(n+1) \cos \left(\frac{\pi}{n+2} \right) - \frac{\sin \left(\frac{n\pi}{n+2} \right)}{\sin \left(\frac{\pi}{n+2} \right)} \cos \left(\frac{n+3}{n+2} \pi \right) \\
 &= \frac{\sin \left(\frac{n\pi}{n+2} \right)}{\sin \left(\frac{\pi}{n+2} \right)} \cos \left(\frac{n+2}{n+2} \pi \right)
 \end{aligned}$$

[∵ $\cos(\alpha) + \cos(\alpha + \beta) + \cos(\alpha + 2\beta) + \dots$

$$\begin{aligned}
 &+ \cos(\alpha + (n-1)\beta) = \frac{\sin \left(\frac{n\beta}{2} \right)}{\sin \left(\frac{\beta}{2} \right)} \cos \left(\frac{2\alpha + (n-1)\beta}{2} \right)] \\
 &(n+1) \cos \left(\frac{\pi}{n+2} \right) - \frac{\sin \left(\pi - \frac{\pi}{n+2} \right)}{\sin \left(\frac{\pi}{n+2} \right)} \cos \left(\pi + \frac{\pi}{n+2} \right) \\
 &= \frac{\sin \left(\pi - \frac{\pi}{n+2} \right)}{\sin \left(\frac{\pi}{n+2} \right)} \cos(\pi)
 \end{aligned}$$

$$\begin{aligned}
 &(n+1) \cos \left(\frac{\pi}{n+2} \right) + \frac{\sin \left(\frac{\pi}{n+2} \right)}{\sin \left(\frac{\pi}{n+2} \right)} \cos \left(\frac{\pi}{n+2} \right) \\
 &= \frac{\sin \left(\frac{\pi}{n+2} \right)}{\sin \left(\frac{\pi}{n+2} \right)} \\
 &\quad (n+1) + \frac{\sin \left(\frac{\pi}{n+2} \right)}{\sin \left(\frac{\pi}{n+2} \right)} \\
 &= \frac{(n+2) \cos \left(\frac{\pi}{n+2} \right)}{(n+2)} = \cos \left(\frac{\pi}{n+2} \right)
 \end{aligned}$$

$$\Rightarrow f(n) = \cos \left(\frac{\pi}{n+2} \right)$$

$$\text{Now, } f(6) = \cos \left(\frac{\pi}{8} \right)$$

$$\therefore \alpha = \tan \left(\cos^{-1} f(6) \right) = \tan \left(\frac{\pi}{8} \right) \left\{ \begin{array}{l} \because \cos^{-1} \cos x = x \\ \text{if } x \in \left(0, \frac{\pi}{2} \right) \end{array} \right.$$

$$= \sqrt{2} - 1$$

$$\Rightarrow (\alpha + 1) = \sqrt{2}$$

$$\Rightarrow (\alpha + 1)^2 = 2$$

$$\Rightarrow \alpha^2 + 2\alpha + 1 = 2$$

$$\Rightarrow \alpha^2 + 2\alpha - 1 = 0$$

$$\text{Now, } f(4) = \cos \left(\frac{\pi}{4+2} \right) = \cos \left(\frac{\pi}{6} \right) = \frac{\sqrt{3}}{2},$$

Now,

$$\begin{aligned}
 \sin(7 \cos^{-1} f(5)) &= \sin \left(7 \cos^{-1} \left(\cos \left(\frac{\pi}{5+2} \right) \right) \right) \\
 &= \sin \left(7 \left(\frac{\pi}{7} \right) \right) = \sin \pi = 0
 \end{aligned}$$

$$\text{and Now, } \lim_{n \rightarrow \infty} f(x) = \lim_{n \rightarrow \infty} \cos \frac{\pi}{n+2} = \cos 0 = 1$$

Hence, options (a), (b) and (c) are correct.

3. Given functions, $f(x) = \log_e(\sin x)$, $(0 < x < \pi)$ and $g(x) = \sin^{-1}(e^{-x})$, $x \geq 0$.

$$\text{Now, } fog(x) = f(g(x)) = f(\sin^{-1}(e^{-x}))$$

$$= \log_e(\sin(\sin^{-1}(e^{-x})))$$

$$= \log_e(e^{-x}) \quad \left\{ \because \sin(\sin^{-1} x) = x, \text{ if } x \in [-1, 1] \right\}$$

$$= -x \quad \dots(i)$$

$$\text{and } (fog)'(x) = \frac{d}{dx}(-x) = -1 \quad \dots(ii)$$

According to the question,

$$\therefore a = (fog)'(\alpha) = -1 \quad [\text{from Eq. (ii)}]$$

$$\text{and } b = (fog)(\alpha) = -\alpha \quad [\text{from Eq. (i)}]$$

for a positive real value 'α'.

Since, the value of $a = -1$ and $b = -\alpha$, satisfy the quadratic equation (from the given options)

$$a\alpha^2 - b\alpha - a = 1.$$

520 Inverse Circular Functions

4. Consider, $\cot \left(\sum_{n=1}^{19} \cot^{-1} \left(1 + \sum_{p=1}^n 2p \right) \right)$

$$= \cot \left(\sum_{n=1}^{19} \cot^{-1} (1 + n(n+1)) \right) \left[\because \sum_{n=1}^{19} p = \frac{n(n+1)}{2} \right]$$

$$= \cot \left(\sum_{n=1}^{19} \cot^{-1} (1 + n + n^2) \right)$$

$$= \cot \left(\sum_{n=1}^{19} \tan^{-1} \frac{1}{1 + n(n+1)} \right)$$

$[\because \cot^{-1} x = \tan^{-1} \frac{1}{x}, \text{ if } x > 0]$

$$= \cot \left(\sum_{n=1}^{19} \tan^{-1} \left(\frac{(n+1) - n}{1 + n(n+1)} \right) \right) \quad [\text{put } 1 = (n+1) - n]$$

$$= \cot \sum_{n=1}^{19} (\tan^{-1} (n+1) - \tan^{-1} n)$$

$$\left[\because \tan^{-1} \frac{x-y}{1+xy} = \tan^{-1} x - \tan^{-1} y \right]$$

$$= \cot [(\tan^{-1} 2 - \tan^{-1} 1) + (\tan^{-1} 3 - \tan^{-1} 2) + \dots + (\tan^{-1} 20 - \tan^{-1} 19)]$$

$$= \cot (\tan^{-1} 20 - \tan^{-1} 1)$$

$$= \cot \left[\left(\frac{\pi}{2} - \cot^{-1} 20 \right) - \left(\frac{\pi}{2} - \cot^{-1} 1 \right) \right]$$

$[\because \tan^{-1} x + \cot^{-1} x = \pi/2]$

$$= \cot (\cot^{-1} 1 - \cot^{-1} 20)$$

$$= \frac{\cot (\cot^{-1} 1) \cot (\cot^{-1} 20) + 1}{\cot (\cot^{-1} 20) - \cot (\cot^{-1} 1)}$$

$[\because \cot (A - B) = \frac{\cot A \cot B + 1}{\cot B - \cot A}]$

$$= \frac{(1 \times 20) + 1}{20 - 1} = \frac{21}{19} \quad [\because \cot (\cot^{-1} x) = x]$$

5. Key Idea Use the formula,
 $\cos^{-1} x + \cos^{-1} y = \cos^{-1} (xy - \sqrt{1-x^2} \sqrt{1-y^2})$

We have, $\cos^{-1} \left(\frac{2}{3x} \right) + \cos^{-1} \left(\frac{3}{4x} \right) = \frac{\pi}{2}$

$$\Rightarrow \cos^{-1} \left(\frac{2}{3x} \cdot \frac{3}{4x} - \sqrt{1 - \frac{4}{9x^2}} \sqrt{1 - \frac{9}{16x^2}} \right) = \frac{\pi}{2}$$

$[\because \cos^{-1} x + \cos^{-1} y = \cos^{-1} (xy - \sqrt{1-x^2} \sqrt{1-y^2})]$

$$\Rightarrow \cos^{-1} \left(\frac{1}{2x^2} - \frac{\sqrt{9x^2 - 4} \sqrt{16x^2 - 9}}{12x^2} \right) = \frac{\pi}{2}$$

$$\Rightarrow \frac{6 - \sqrt{9x^2 - 4} \sqrt{16x^2 - 9}}{12x^2} = \cos \frac{\pi}{2} = 0$$

$$\Rightarrow \sqrt{9x^2 - 4} \sqrt{16x^2 - 9} = 6$$

On squaring both sides,

$$\Rightarrow (9x^2 - 4)(16x^2 - 9) = 36$$

$$\Rightarrow 144x^4 - 81x^2 - 64x^2 + 36 = 36$$

$$\Rightarrow 144x^4 - 145x^2 = 0$$

$$\Rightarrow x^2(144x^2 - 145) = 0$$

$$\Rightarrow x = 0 \text{ or } x = \pm \sqrt{\frac{145}{144}} = \pm \frac{\sqrt{145}}{12}$$

But $x > \frac{3}{4}$, $x = \frac{\sqrt{145}}{12}$

6. Here, $\alpha = 3 \sin^{-1} \left(\frac{6}{11} \right)$ and $\beta = 3 \cos^{-1} \left(\frac{4}{9} \right)$ as $\frac{6}{11} > \frac{1}{2}$

$$\Rightarrow \sin^{-1} \left(\frac{6}{11} \right) > \sin^{-1} \left(\frac{1}{2} \right) = \frac{\pi}{6}$$

$$\therefore \alpha = 3 \sin^{-1} \left(\frac{6}{11} \right) > \frac{\pi}{2} \Rightarrow \cos \alpha < 0$$

Now, $\beta = 3 \cos^{-1} \left(\frac{4}{9} \right)$

As $\frac{4}{9} < \frac{1}{2} \Rightarrow \cos^{-1} \left(\frac{4}{9} \right) > \cos^{-1} \left(\frac{1}{2} \right) = \frac{\pi}{3}$

$$\therefore \beta = 3 \cos^{-1} \left(\frac{4}{9} \right) > \pi$$

$$\therefore \cos \beta < 0 \text{ and } \sin \beta < 0$$

Now, $\alpha + \beta$ is slightly greater than $\frac{3\pi}{2}$.

$$\therefore \cos (\alpha + \beta) > 0$$

7. We have, $0 < x < 1$
Let $\cot^{-1} x = \theta$

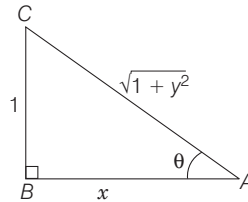

$$\Rightarrow \cot \theta = x$$

$$\Rightarrow \sin \theta = \frac{1}{\sqrt{1+x^2}} = \sin (\cot^{-1} x)$$

and $\cos \theta = \frac{x}{\sqrt{1+x^2}} = \cos (\cot^{-1} x)$

Now, $\sqrt{1+x^2} [\{ x \cos (\cot^{-1} x) + \sin (\cot^{-1} x) \}^2 - 1]^{1/2}$

$$= \sqrt{1+x^2} \left[\left(x \frac{x}{\sqrt{1+x^2}} + \frac{1}{\sqrt{1+x^2}} \right)^2 - 1 \right]^{1/2}$$

$$= \sqrt{1+x^2} \left[\left(\frac{1+x^2}{\sqrt{1+x^2}} \right)^2 - 1 \right]^{1/2}$$

$$= \sqrt{1+x^2} [1+x^2 - 1]^{1/2} = x\sqrt{1+x^2}$$

8. Given, $\sin [\cot^{-1} (1+x)] = \cos (\tan^{-1} x)$... (i)

and we know that,

$$\cot^{-1} \theta = \sin^{-1} \left(\frac{1}{\sqrt{1+\theta^2}} \right) \text{ and } \tan^{-1} \theta = \cos^{-1} \left(\frac{1}{\sqrt{1+\theta^2}} \right)$$

From Eq. (i),

$$\begin{aligned} \sin \left(\sin^{-1} \frac{1}{\sqrt{1+(1+x)^2}} \right) &= \cos \left(\cos^{-1} \frac{1}{\sqrt{1+x^2}} \right) \\ \Rightarrow \frac{1}{\sqrt{1+(1+x)^2}} &= \frac{1}{\sqrt{1+x^2}} \\ \Rightarrow 1+x^2+2x+1 &= x^2+1 \\ \Rightarrow x &= -\frac{1}{2} \end{aligned}$$

9. We know that, $\sin^{-1}(\alpha) + \cos^{-1}(\alpha) = \frac{\pi}{2}$

Therefore, α should be equal in both functions.

$$\begin{aligned} \therefore x - \frac{x^2}{2} + \frac{x^3}{4} - \dots &= x^2 - \frac{x^4}{2} + \frac{x^6}{4} - \dots \\ \Rightarrow \frac{x}{1+\frac{x}{2}} &= \frac{x^2}{1+\frac{x^2}{2}} \Rightarrow \frac{x}{2+x} = \frac{x^2}{2+x^2} \Rightarrow \frac{2x}{2+x} = \frac{2x^2}{2+x^2} \\ \Rightarrow 2x(2+x^2) &= 2x^2(2+x) \\ \Rightarrow 4x+2x^3 &= 4x^2+2x^3 \\ \Rightarrow x(4+2x^2-4x-2x^2) &= 0 \\ \Rightarrow \text{Either } x=0 \text{ or } 4-4x &= 0 \\ \Rightarrow x=0 \text{ or } x=1 \\ \therefore 0 < |x| < \sqrt{2} \\ \therefore x=1 \text{ and } x \neq 0 \end{aligned}$$

10. $\sin^{-1} \left(\sin \frac{2\pi}{3} \right) = \sin^{-1} \left[\sin \left(\pi - \frac{\pi}{3} \right) \right] = \sin^{-1} \left(\sin \frac{\pi}{3} \right) = \frac{\pi}{3}$

11. P. Here, innermost function is inverse.

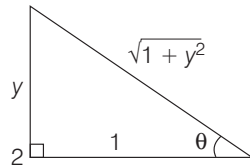

$$\begin{aligned} \therefore \text{Put } \tan^{-1} y = \theta \Rightarrow \tan \theta &= y \\ \left[\frac{1}{y^2} \cdot \left\{ \frac{\cos(\tan^{-1} y) + y \sin(\tan^{-1} y)}{\cot(\sin^{-1} y) + \tan(\sin^{-1} y)} \right\}^2 + y^4 \right]^{1/2} \\ = \left[\frac{1}{y^2} \cdot \left\{ \frac{\frac{1}{\sqrt{1+y^2}} + \frac{y^2}{\sqrt{1+y^2}}}{\frac{\sqrt{1-y^2}}{y} + \frac{y}{\sqrt{1-y^2}}} \right\}^2 + y^4 \right]^{1/2} \\ = \left[\frac{1}{y^2} \cdot y^2(1-y^4) + y^4 \right]^{1/2} = 1 \end{aligned}$$

Q. Given, $\cos x + \cos y = -\cos z$

and $\sin x + \sin y = -\sin z$

On squaring and adding, we get

$$\begin{aligned} \cos^2 x + \sin^2 x + \cos^2 y + \sin^2 y + 2 \cos x \cos y \\ + 2 \sin x \sin y = 1 \\ \Rightarrow 2 + 2 [\cos(x-y)] = 1 \Rightarrow \cos(x-y) = -\frac{1}{2} \end{aligned}$$

$$\Rightarrow 2 \cos^2 \left(\frac{x-y}{2} \right) - 1 = -\frac{1}{2}$$

$$\Rightarrow 2 \cos^2 \left(\frac{x-y}{2} \right) = \frac{1}{2} \Rightarrow \cos \left(\frac{x-y}{2} \right) = \frac{1}{2}$$

R. $\cos 2x \cdot \left(\cos \left(\frac{\pi}{4} - x \right) - \cos \left(\frac{\pi}{4} + x \right) \right) + 2 \sin^2 x = 2 \sin x \cdot \cos x$

$$\Rightarrow \cos 2x \cdot (\sqrt{2} \sin x) + 2 \sin^2 x = 2 \sin x \cdot \cos x$$

$$\Rightarrow \sqrt{2} \sin x [\cos 2x + \sqrt{2} \sin x - \sqrt{2} \cos x] = 0$$

$$\Rightarrow \sin x = 0, (\cos x - \sin x) (\cos x + \sin x - \sqrt{2}) = 0$$

$$\Rightarrow \sec x = 1 \text{ or } \tan x = 1 \Rightarrow \sec x = 1 \text{ or } \sqrt{2}$$

S. $\cot(\sin^{-1} \sqrt{1-x^2}) = \sin(\tan^{-1}(x\sqrt{6}))$

$$\Rightarrow \frac{x}{\sqrt{1-x^2}} = \frac{x\sqrt{6}}{\sqrt{1+6x^2}}$$

$$\Rightarrow 1+6x^2 = 6-6x^2$$

$$\Rightarrow 12x^2 = 5 \Rightarrow x = \sqrt{\frac{5}{12}} = \frac{\sqrt{5}}{2\sqrt{3}}$$

(P) \rightarrow 4, (Q) \rightarrow 3, (R) \rightarrow 2 or 4, (S) \rightarrow 1

12. A. If $a = 1, b = 0$, then $\sin^{-1} x + \cos^{-1} y = 0$

$$\Rightarrow \sin^{-1} x = -\cos^{-1} y \Rightarrow x^2 + y^2 = 1$$

B. If $a = 1$ and $b = 1$, then

$$\sin^{-1} x + \cos^{-1} y + \cos^{-1} xy = \frac{\pi}{2}$$

$$\Rightarrow \cos^{-1} x - \cos^{-1} y = \cos^{-1} xy$$

$$\Rightarrow xy + \sqrt{1-x^2} \sqrt{1-y^2} = xy \Rightarrow (x^2-1)(y^2-1) = 0$$

C. If $a = 1, b = 2$, then

$$\sin^{-1} x + \cos^{-1} y + \cos^{-1}(2xy) = \frac{\pi}{2}$$

$$\Rightarrow \cos^{-1} x - \cos^{-1} y = \cos^{-1}(2xy)$$

$$\Rightarrow xy + \sqrt{1-x^2} \sqrt{1-y^2} = 2xy \Rightarrow x^2 + y^2 = 1$$

D. If $a = 2$ and $b = 2$, then

$$\sin^{-1}(2x) + \cos^{-1}(y) + \cos^{-1}(2xy) = \frac{\pi}{2}$$

$$\Rightarrow \cos^{-1}(2x) - \cos^{-1}(y) = \cos^{-1}(2xy)$$

$$\Rightarrow 2xy + \sqrt{1-4x^2} \sqrt{1-y^2} = 2xy$$

$$\Rightarrow (4x^2-1)(y^2-1) = 0$$

Hence, A \rightarrow p; B \rightarrow q; C \rightarrow p; D \rightarrow s

522 Inverse Circular Functions

13. We have,

$$E_1 = \left\{ x \in R : x \neq 1 \text{ and } \frac{x}{x-1} > 0 \right\}$$

$$\therefore E_1 = \frac{x}{x-1} > 0$$

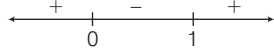

$$E_1 = x \in (-\infty, 0) \cup (1, \infty)$$

and

$$E_2 = \left\{ x \in E_1 : \sin^{-1} \left(\log_e \left(\frac{x}{x-1} \right) \right) \text{ is a real number} \right\}$$

$$E_2 = -1 \leq \log_e \frac{x}{x-1} \leq 1 \Rightarrow e^{-1} \leq \frac{x}{x-1} \leq e$$

$$\text{Now, } \frac{x}{x-1} \geq e^{-1} \Rightarrow \frac{x}{x-1} - \frac{1}{e} \geq 0$$

$$\Rightarrow \frac{ex - x + 1}{e(x-1)} \geq 0 \Rightarrow \frac{x(e-1) + 1}{(x-1)e} \geq 0$$

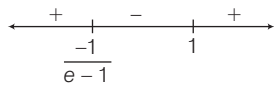

$$\Rightarrow x \in \left(-\infty, \frac{1}{1-e} \right] \cup (1, \infty)$$

$$\text{Also, } \frac{x}{x-1} \leq e$$

$$\Rightarrow \frac{(e-1)x - e}{x-1} \geq 0$$

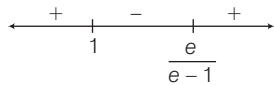

$$\Rightarrow x \in (-\infty, 1) \cup \left[\frac{e}{e-1}, \infty \right)$$

$$\text{So, } E_2 = \left(-\infty, \frac{1}{1-e} \right] \cup \left[\frac{e}{e-1}, \infty \right)$$

\therefore The domain of f and g are

$$\left(-\infty, \frac{1}{1-e} \right] \cup \left[\frac{e}{e-1}, \infty \right)$$

and Range of $\frac{x}{x-1}$ is $R^+ - \{1\}$

$$\Rightarrow \text{Range of } f \text{ is } R - \{0\} \text{ or } (-\infty, 0) \cup (0, \infty)$$

$$\text{Range of } g \text{ is } \left[-\frac{\pi}{2}, \frac{\pi}{2} \right] - \{0\} \text{ or } \left[-\frac{\pi}{2}, 0 \right) \cup \left(0, \frac{\pi}{2} \right]$$

Now, $P \rightarrow 4, Q \rightarrow 2, R \rightarrow 1, S \rightarrow 1$

$$\begin{aligned} 14. \therefore \sum_{k=0}^{10} \sec \left(\frac{7\pi}{12} + \frac{k\pi}{2} \right) \sec \left(\frac{7\pi}{12} + \frac{(k+1)\pi}{2} \right) \\ = \sum_{k=0}^{10} \frac{1}{\cos \left(\frac{7\pi}{12} + \frac{k\pi}{2} \right) \cos \left(\frac{7\pi}{12} + \frac{(k+1)\pi}{2} \right)} \end{aligned}$$

$$\begin{aligned} &= \sum_{k=0}^{10} \frac{\sin \left[\left(\frac{7\pi}{12} + \frac{(k+1)\pi}{2} \right) - \left(\frac{7\pi}{12} + \frac{k\pi}{2} \right) \right]}{\cos \left(\frac{7\pi}{12} + \frac{k\pi}{2} \right) \cos \left(\frac{7\pi}{12} + \frac{(k+1)\pi}{2} \right)} \\ &\quad \left[\because \frac{7\pi}{12} + \frac{(k+1)\pi}{2} - \left(\frac{7\pi}{12} + \frac{k\pi}{2} \right) = \frac{\pi}{2} \text{ and } \sin \frac{\pi}{2} = 1 \right] \\ &= \sum_{k=0}^{10} \frac{\sin \left(\frac{7\pi}{12} + \frac{(k+1)\pi}{2} \right) \cos \left(\frac{7\pi}{12} + \frac{k\pi}{2} \right) - \sin \left(\frac{7\pi}{12} + \frac{k\pi}{2} \right) \cos \left(\frac{7\pi}{12} + \frac{(k+1)\pi}{2} \right)}{\cos \left(\frac{7\pi}{12} + \frac{k\pi}{2} \right) \cos \left(\frac{7\pi}{12} + \frac{(k+1)\pi}{2} \right)} \\ &= \sum_{k=0}^{10} \left[\tan \left(\frac{7\pi}{12} + \frac{(k+1)\pi}{2} \right) - \tan \left(\frac{7\pi}{12} + \frac{k\pi}{2} \right) \right] \\ &= \tan \left(\frac{7\pi}{12} + \frac{\pi}{2} \right) - \tan \left(\frac{7\pi}{12} \right) \\ &\quad + \tan \left(\frac{7\pi}{12} + \frac{2\pi}{2} \right) - \tan \left(\frac{7\pi}{12} + \frac{\pi}{2} \right) \\ &\quad \vdots \\ &\quad \vdots \\ &\quad + \tan \left(\frac{7\pi}{12} + \frac{11\pi}{2} \right) - \tan \left(\frac{7\pi}{12} + \frac{10\pi}{2} \right) \\ &= \tan \left(\frac{7\pi}{12} + \frac{11\pi}{2} \right) - \tan \frac{7\pi}{12} = \tan \frac{\pi}{12} + \cot \frac{\pi}{12} \\ &= \frac{1}{\sin \frac{\pi}{12} \cos \frac{\pi}{12}} = \frac{2}{\sin \frac{\pi}{6}} = 4 \end{aligned}$$

$$\begin{aligned} \text{So, } \sec^{-1} \left(\frac{1}{4} \sum_{k=0}^{10} \sec \left(\frac{7\pi}{12} + \frac{k\pi}{2} \right) \sec \left(\frac{7\pi}{12} + \frac{(k+1)\pi}{2} \right) \right) \\ = \sec^{-1}(1) = 0 \end{aligned}$$

15. We have,

$$\begin{aligned} \sin^{-1} \left(\sum_{i=1}^{\infty} x^{i+1} - x \sum_{i=1}^{\infty} \left(\frac{x}{2} \right)^i \right) \\ = \frac{\pi}{2} - \cos^{-1} \left(\sum_{i=1}^{\infty} \left(\frac{-x}{2} \right)^i - \sum_{i=1}^{\infty} (-x)^i \right) \\ \Rightarrow \sin^{-1} \left[\frac{x^2}{1-x} - \frac{x \cdot \frac{x}{2}}{1 - \frac{x}{2}} \right] = \frac{\pi}{2} - \cos^{-1} \left[\frac{-x}{1 + \frac{x}{2}} - \frac{(-x)}{1+x} \right] \\ \quad \left[\because \sum_{i=1}^{\infty} x^{i+1} = x^2 + x^3 + x^4 + \dots = \frac{x^2}{1-x} \right. \\ \quad \left. \text{using sum of infinite terms of GP} \right] \\ \Rightarrow \sin^{-1} \left[\frac{x^2}{1-x} - \frac{x^2}{2-x} \right] = \frac{\pi}{2} - \cos^{-1} \left[\frac{x}{1+x} - \frac{x}{2+x} \right] \\ \Rightarrow \sin^{-1} \left[\frac{x^2}{1-x} - \frac{x^2}{2-x} \right] = \sin^{-1} \left(\frac{x}{1+x} - \frac{x}{2+x} \right) \\ \quad \left[\because \sin^{-1} x = \frac{\pi}{2} - \cos^{-1} x \right] \end{aligned}$$

$$\begin{aligned} \Rightarrow \frac{x^2}{1-x} - \frac{x^2}{2-x} &= \frac{x}{1+x} - \frac{x}{2+x} \\ \Rightarrow x^2 \left(\frac{2-x-1+x}{(1-x)(2-x)} \right) &= x \frac{(2+x-1-x)}{(1+x)(2+x)} \\ \Rightarrow \frac{x}{2-3x+x^2} &= \frac{1}{2+3x+x^2} \text{ or } x=0 \\ \Rightarrow x^3 + 3x^2 + 2x &= x^2 - 3x + 2 \\ \Rightarrow x^3 + 2x^2 + 5x - 2 &= 0 \text{ or } x=0 \\ \text{Let } f(x) &= x^3 + 2x^2 + 5x - 2 \\ f'(x) &= 3x^2 + 4x + 5 \\ f'(x) &> 0, \forall x \in R \end{aligned}$$

∴ $x^3 + 2x^2 + 5x - 2$ has only one real roots
Therefore, total number of real solution is 2.

16. PLAN

- (i) Using definition of $f(x) = \cos^{-1}(x)$, we trace the curve $f(x) = \cos^{-1}(\cos x)$.
- (ii) The number of solutions of equations involving trigonometric and algebraic functions and involving both functions are found using graphs of the curves.

$$\text{We know that, } \cos^{-1}(\cos x) = \begin{cases} x, & \text{if } x \in [0, \pi] \\ 2\pi - x, & \text{if } x \in [\pi, 2\pi] \\ -2\pi + x, & \text{if } x \in [2\pi, 3\pi] \\ 4\pi - x, & \text{if } x \in [3\pi, 4\pi] \end{cases}$$

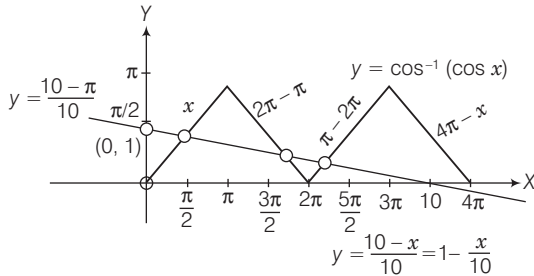

From above graph, it is clear that $y = \frac{10-x}{10}$ and $y = \cos^{-1}(\cos x)$ intersect at three distinct points, so number of solutions is 3.

17. LHS = $\cos \tan^{-1}[\sin(\cot^{-1} x)]$

$$\begin{aligned} &= \cos \tan^{-1} \left[\sin \left(\sin^{-1} \frac{1}{\sqrt{1+x^2}} \right) \right] \\ &= \cos \left(\tan^{-1} \frac{1}{\sqrt{1+x^2}} \right) \\ &= \frac{\sqrt{x^2+1}}{\sqrt{x^2+2}} = \text{RHS} \end{aligned}$$

18. Let $f(x) = \cos(2 \cos^{-1} x + \sin^{-1} x)$

$$\begin{aligned} &= \cos \left(\cos^{-1} x + \frac{\pi}{2} \right) \left[\because \cos^{-1} x + \sin^{-1} x = \frac{\pi}{2} \right] \\ &= -\sin(\cos^{-1} x) \\ \Rightarrow f(x) &= -\sin(\sin^{-1} \sqrt{1-x^2}) \end{aligned}$$

$$\begin{aligned} \Rightarrow f\left(\frac{1}{5}\right) &= -\sin \left(\sin^{-1} \sqrt{1-\frac{1}{5^2}} \right) \\ &= -\sin \left(\sin^{-1} \frac{2\sqrt{6}}{5} \right) = -\frac{2\sqrt{6}}{5} \end{aligned}$$

Topic 3 Sum and Difference Formulae

1. Key Idea Use formulae

- (i) $\sin^{-1} x - \sin^{-1} y$
 $= \sin^{-1}(x\sqrt{1-y^2} - y\sqrt{1-x^2})$ if $x^2 + y^2 \leq 1$
 or if $xy > 0$ and $x^2 + y^2 > 1 \forall x, y \in [-1, 1]$
- (ii) $\sin^{-1} x = \cos^{-1} \sqrt{1-x^2}$ and
- (iii) $\sin^{-1} \theta + \cos^{-1} \theta = \frac{\pi}{2}$

We have,

$$\begin{aligned} \sin^{-1} \left(\frac{12}{13} \right) - \sin^{-1} \left(\frac{3}{5} \right) \\ = \sin^{-1} \left(\frac{12}{13} \sqrt{1-\left(\frac{3}{5}\right)^2} - \frac{3}{5} \sqrt{1-\left(\frac{12}{13}\right)^2} \right) \end{aligned}$$

$$[\because \sin^{-1} x - \sin^{-1} y = \sin^{-1}(x\sqrt{1-y^2} - y\sqrt{1-x^2}),$$

if $x^2 + y^2 \leq 1$ or if $xy > 0$ and $x^2 + y^2 > 1 \forall x, y \in [-1, 1]]$

$$\begin{aligned} &= \sin^{-1} \left(\frac{12}{13} \times \frac{4}{5} - \frac{3}{5} \times \frac{5}{13} \right) \\ &= \sin^{-1} \left(\frac{48-15}{65} \right) = \sin^{-1} \left(\frac{33}{65} \right) \end{aligned}$$

$$= \cos^{-1} \sqrt{1-\left(\frac{33}{65}\right)^2}$$

$$= \cos^{-1} \frac{\sqrt{3136}}{\sqrt{4225}} \quad [\because \sin^{-1} x = \cos^{-1} \sqrt{1-x^2}]$$

$$= \cos^{-1} \left(\frac{56}{65} \right) = \frac{\pi}{2} - \sin^{-1} \left(\frac{56}{65} \right)$$

$$\left[\because \sin^{-1} \theta + \cos^{-1} \theta = \frac{\pi}{2} \right]$$

2. Given equation is

$$\cos^{-1} x - \cos^{-1} \frac{y}{2} = \alpha, \text{ where } -1 \leq x \leq 1,$$

$$-2 \leq y \leq 2 \text{ and } x \leq \frac{y}{2} \quad \therefore$$

$$\cos^{-1} \left(x \frac{y}{2} + \sqrt{1-x^2} \sqrt{1-(y/2)^2} \right) = \alpha$$

$$[\because \cos^{-1} x - \cos^{-1} y = \cos^{-1}(xy + \sqrt{1-x^2} \sqrt{1-y^2}),$$

$$|x|, |y| \leq 1 \text{ and } x + y \geq 0]$$

$$\Rightarrow \frac{xy}{2} + \sqrt{1-x^2} \sqrt{1-(y/2)^2} = \cos \alpha$$

$$\Rightarrow \sqrt{1-x^2} \sqrt{1-(y/2)^2} = \cos \alpha - \frac{xy}{2}$$

524 Inverse Circular Functions

On squaring both sides, we get

$$\begin{aligned} (1-x^2)\left(1-\frac{y^2}{4}\right) &= \cos^2\alpha + \frac{x^2y^2}{4} - 2\frac{xy}{2}\cos\alpha \\ \Rightarrow 1-x^2-\frac{y^2}{4}+\frac{x^2y^2}{4} &= \cos^2\alpha + \frac{x^2y^2}{4} - xy\cos\alpha \\ \Rightarrow x^2+\frac{y^2}{4}-xy\cos\alpha &= 1-\cos^2\alpha \\ \Rightarrow 4x^2-4xy\cos\alpha+y^2 &= 4\sin^2\alpha \end{aligned}$$

3. Given, $\alpha = \cos^{-1}\left(\frac{3}{5}\right)$ and $\beta = \tan^{-1}\left(\frac{1}{3}\right)$

where, $0 < \alpha, \beta < \frac{\pi}{2}$

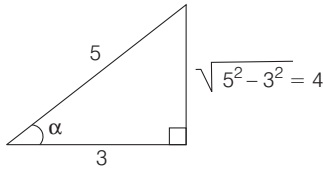

Clearly, $\alpha = \tan^{-1}\frac{4}{3}$

So, $\alpha - \beta = \tan^{-1}\frac{4}{3} - \tan^{-1}\frac{1}{3} = \tan^{-1}\left(\frac{\frac{4}{3} - \frac{1}{3}}{1 + \left(\frac{4}{3} \times \frac{1}{3}\right)}\right)$

$$\begin{aligned} &\left[\because \tan^{-1}x - \tan^{-1}y = \tan^{-1}\frac{x-y}{1+xy}, \text{ if } xy > -1 \right] \\ &= \tan^{-1}\frac{1}{1+\frac{4}{9}} = \tan^{-1}\frac{9}{13} \end{aligned}$$

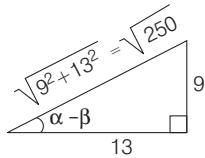

$$\begin{aligned} &= \sin^{-1}\frac{9}{\sqrt{9^2+13^2}} = \sin^{-1}\frac{9}{\sqrt{250}} \\ &= \sin^{-1}\left(\frac{9}{5\sqrt{10}}\right) \end{aligned}$$

4. Given equation is

$$\tan^{-1}(2x) + \tan^{-1}(3x) = \frac{\pi}{4}, x \geq 0$$

$$\Rightarrow \tan^{-1}\frac{5x}{1-6x^2} = \frac{\pi}{4}, 6x^2 < 1$$

$$\left[\because \tan^{-1}x + \tan^{-1}y = \tan^{-1}\left(\frac{x+y}{1-xy}\right), xy < 1 \right]$$

$$\Rightarrow \frac{5x}{1-6x^2} = 1, x^2 < \frac{1}{6}$$

$$\Rightarrow 6x^2 + 5x - 1 = 0, 0 \leq x < \frac{1}{\sqrt{6}} \quad [\because x \geq 0]$$

$$\Rightarrow 6x^2 + 6x - x - 1 = 0, 0 \leq x < \frac{1}{\sqrt{6}}$$

$$\Rightarrow 6x(x+1) - 1(x+1) = 0, \quad 0 \leq x < \frac{1}{\sqrt{6}}$$

$$\Rightarrow (6x-1)(x+1) = 0, \quad 0 \leq x < \frac{1}{\sqrt{6}}$$

$$\Rightarrow x = \frac{1}{6}, -1, \quad 0 \leq x < \frac{1}{\sqrt{6}}$$

$$\Rightarrow x = \frac{1}{6}, \quad \left[\because 0 \leq x < \frac{1}{\sqrt{6}} \right]$$

So 'A' is a singleton set.

\therefore The solution of given differential equation represents a circle with centre on the X-axis.

5. The graph of $y = \sin^{-1}(\sin x)$ is

$$\therefore x = \sin^{-1}(\sin 10) = -10 + 3\pi \quad \dots(i)$$

and the graph of $y = \cos^{-1}(\cos x)$ is

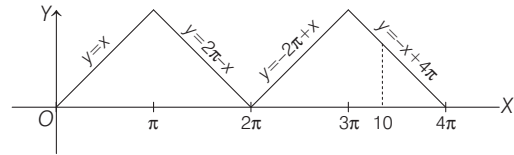

$$\therefore y = \cos^{-1}(\cos 10) = -10 + 4\pi \quad \dots(ii)$$

Now, from Eqs. (i) and (ii),

$$y - x = (-10 + 4\pi) - (-10 + 3\pi) = \pi$$

6. Given, $\tan^{-1}y = \tan^{-1}x + \tan^{-1}\left(\frac{2x}{1-x^2}\right)$

$$\text{where } |x| < \frac{1}{\sqrt{3}} \Rightarrow \tan^{-1}y = \tan^{-1}\left\{ \frac{x + \frac{2x}{1-x^2}}{1 - x\left(\frac{2x}{1-x^2}\right)} \right\}$$

$$\left[\because \tan^{-1}x + \tan^{-1}y = \tan^{-1}\left(\frac{x+y}{1-xy}\right), \right.$$

where $x > 0, y > 0$ and $xy < 1$]

$$= \tan^{-1}\left(\frac{x-x^3+2x}{1-x^2-2x^2}\right)$$

$$\tan^{-1}y = \tan^{-1}\left(\frac{3x-x^3}{1-3x^2}\right)$$

$$\Rightarrow y = \frac{3x-x^3}{1-3x^2}$$

$$|x| < \frac{1}{\sqrt{3}}$$

$$\Rightarrow -\frac{1}{\sqrt{3}} < x < \frac{1}{\sqrt{3}}$$

Let $x = \tan \theta$

$$\Rightarrow -\frac{\pi}{6} < \theta < \frac{\pi}{6}$$

$$\therefore \tan^{-1} y = \theta + \tan^{-1}(\tan 2\theta) = \theta + 2\theta = 3\theta$$

$$\Rightarrow y = \tan 3\theta$$

$$\Rightarrow y = \frac{3 \tan \theta - \tan^3 \theta}{1 - 3 \tan^2 \theta}$$

$$\Rightarrow y = \frac{3x - x^3}{1 - 3x^2}$$

7. We have, $\cot \left[\sum_{n=1}^{23} \cot^{-1} \left(1 + \sum_{k=1}^n 2k \right) \right]$

$$\Rightarrow \cot \left[\sum_{n=1}^{23} \cot^{-1} (1 + 2 + 4 + 6 + 8 + \dots + 2n) \right]$$

$$\Rightarrow \cot \left[\sum_{n=1}^{23} \cot^{-1} \{1 + n(n+1)\} \right]$$

$$\Rightarrow \cot \left[\sum_{n=1}^{23} \tan^{-1} \frac{1}{1 + n(n+1)} \right]$$

$$\Rightarrow \cot \left[\sum_{n=1}^{23} \tan^{-1} \left\{ \frac{(n+1) - n}{1 + n(n+1)} \right\} \right]$$

$$\Rightarrow \cot \left[\sum_{n=1}^{23} (\tan^{-1}(n+1) - \tan^{-1} n) \right]$$

$$\Rightarrow \cot [(\tan^{-1} 2 - \tan^{-1} 1) + (\tan^{-1} 3 - \tan^{-1} 2) + (\tan^{-1} 4 - \tan^{-1} 3) + \dots + (\tan^{-1} 24 - \tan^{-1} 23)]$$

$$\Rightarrow \cot (\tan^{-1} 24 - \tan^{-1} 1)$$

$$\Rightarrow \cot \left(\tan^{-1} \frac{24-1}{1+24 \cdot 1} \right) = \cot \left(\tan^{-1} \frac{23}{25} \right)$$

$$= \cot \left(\cot^{-1} \frac{25}{23} \right) = \frac{25}{23}$$

8. Since, x, y and z are in an AP.

$$\therefore 2y = x + z$$

Also, $\tan^{-1} x, \tan^{-1} y$ and $\tan^{-1} z$ are in an AP.

$$\therefore 2 \tan^{-1} y = \tan^{-1} x + \tan^{-1} z$$

$$\Rightarrow \tan^{-1} \left(\frac{2y}{1-y^2} \right) = \tan^{-1} \left(\frac{x+z}{1-xz} \right)$$

$$\Rightarrow \frac{x+z}{1-y^2} = \frac{x+z}{1-xz} \Rightarrow y^2 = xz$$

Since x, y and z are in an AP as well as in a GP.

$$\therefore x = y = z$$

9. $\tan \left[\cos^{-1} \left(\frac{4}{5} \right) + \tan^{-1} \left(\frac{2}{3} \right) \right] = \tan \left[\tan^{-1} \left(\frac{3}{4} \right) + \tan^{-1} \left(\frac{2}{3} \right) \right]$

$$\left[\because \cos^{-1} \left(\frac{4}{5} \right) = \tan^{-1} \left(\frac{3}{4} \right) \right]$$

$$= \tan \left[\tan^{-1} \left(\frac{\frac{3}{4} + \frac{2}{3}}{1 - \frac{3}{4} \cdot \frac{2}{3}} \right) \right] = \tan \left[\tan^{-1} \left(\frac{17}{6} \right) \right] = \frac{17}{6}$$

10. $\tan \left[2 \tan^{-1} \left(\frac{1}{5} \right) - \frac{\pi}{4} \right] = \tan \left[\tan^{-1} \left(\frac{2 \cdot \frac{1}{5}}{1 - \frac{1}{25}} \right) - \frac{\pi}{4} \right]$

$$= \tan \left[\tan^{-1} \left(\frac{5}{12} \right) - \frac{\pi}{4} \right]$$

$$= \frac{\tan \left[\tan^{-1} \left(\frac{5}{12} \right) \right] - \tan \left(\frac{\pi}{4} \right)}{1 + \tan \left[\tan^{-1} \left(\frac{5}{12} \right) \right] \tan \frac{\pi}{4}}$$

$$= \frac{\frac{5}{12} - 1}{1 + \frac{5}{12} \cdot 1} = -\frac{7}{17}$$

11. Given,

$$\theta = \tan^{-1} \sqrt{\frac{a(a+b+c)}{bc}} + \tan^{-1} \sqrt{\frac{b(a+b+c)}{ac}} + \tan^{-1} \sqrt{\frac{c(a+b+c)}{ab}}$$

$$\left[\because \tan^{-1} x + \tan^{-1} y + \tan^{-1} z = \tan^{-1} \left(\frac{x+y+z-xyz}{1-xy-yz-zx} \right) \right]$$

$$= \tan^{-1} \left[\frac{\sqrt{a+b+c} \left(\sqrt{\frac{a}{bc}} + \sqrt{\frac{b}{ca}} + \sqrt{\frac{c}{ab}} \right) - (a+b+c) \sqrt{\frac{a+b+c}{abc}}}{1 - (a+b+c) \left(\frac{1}{a} + \frac{1}{b} + \frac{1}{c} \right)} \right]$$

$$= \tan^{-1} \left[\frac{\sqrt{\frac{a+b+c}{abc}} (a+b+c) - (a+b+c) \sqrt{\frac{a+b+c}{abc}}}{1 - \frac{(a+b+c)(ab+bc+ca)}{abc}} \right]$$

$$\Rightarrow \theta = \tan^{-1} 0$$

$$\Rightarrow \tan \theta = 0$$

12. Given, $\tan^{-1} 2x + \tan^{-1} 3x = \frac{\pi}{4}$

$$\Rightarrow \tan^{-1} \left(\frac{2x+3x}{1-6x^2} \right) = \frac{\pi}{4} \Rightarrow \frac{5x}{1-6x^2} = 1$$

$$\Rightarrow 6x^2 + 5x - 1 = 0$$

$$\Rightarrow (x+1)(6x-1) = 0$$

$$\Rightarrow x = -1 \text{ or } \frac{1}{6}$$

But $x = -1$ does not satisfy the given equation.

$$\therefore \text{We take } x = \frac{1}{6}$$

23

Properties of Triangles

Topic 1 Applications of Sine, Cosine, Projection and Half Angle Formulae

Objective Questions I (Only one correct option)

1. The angles A, B and C of a $\triangle ABC$ are in AP and $a : b = 1 : \sqrt{3}$. If $c = 4$ cm, then the area (in sq cm) of this triangle is (2019 Main, 10 April II)

- (a) $\frac{2}{\sqrt{3}}$ (b) $4\sqrt{3}$ (c) $2\sqrt{3}$ (d) $\frac{4}{\sqrt{3}}$

2. Given, $\frac{b+c}{11} = \frac{c+a}{12} = \frac{a+b}{13}$ for a $\triangle ABC$ with usual notation. If $\frac{\cos A}{\alpha} = \frac{\cos B}{\beta} = \frac{\cos C}{\gamma}$, then the ordered triad (α, β, γ) has a value (2019 Main, 11 Jan II)

- (a) (19, 7, 25) (b) (3, 4, 5)
(c) (5, 12, 13) (d) (7, 19, 25)

3. In a triangle, the sum of lengths of two sides is x and the product of the lengths of the same two sides is y . If $x^2 - c^2 = y$, where c is the length of the third side of the triangle, then the circumradius of the triangle is (2019 Main, 11 Jan I)

- (a) $\frac{c}{3}$ (b) $\frac{c}{\sqrt{3}}$
(c) $\frac{3}{2}y$ (d) $\frac{y}{\sqrt{3}}$

4. $ABCD$ is a trapezium such that AB and CD are parallel and $BC \perp CD$, if $\angle ADB = \theta$, $BC = p$ and $CD = q$, then AB is equal to (2013 Main)

- (a) $\frac{(p^2 + q^2)\sin\theta}{p\cos\theta + q\sin\theta}$ (b) $\frac{p^2 + q^2\cos\theta}{p\cos\theta + q\sin\theta}$
(c) $\frac{p^2 + q^2}{p^2\cos\theta + q^2\sin\theta}$ (d) $\frac{(p^2 + q^2)\sin\theta}{(p\cos\theta + q\sin\theta)^2}$

5. If the angles A, B and C of a triangle are in an arithmetic progression and if a, b and c denote the lengths of the sides opposite to A, B and C respectively, then the value of the expression $\frac{a}{c}\sin 2C + \frac{c}{a}\sin 2A$ is (2010)

- (a) $\frac{1}{2}$ (b) $\frac{\sqrt{3}}{2}$ (c) 1 (d) $\sqrt{3}$

6. In a $\triangle ABC$, among the following which one is true? (2005, 1M)

(a) $(b+c)\cos\frac{A}{2} = a\sin\left(\frac{B+C}{2}\right)$

(b) $(b+c)\cos\left(\frac{B+C}{2}\right) = a\sin\frac{A}{2}$

(c) $(b-c)\cos\left(\frac{B-C}{2}\right) = a\cos\left(\frac{A}{2}\right)$

(d) $(b-c)\cos\frac{A}{2} = a\sin\left(\frac{B-C}{2}\right)$

7. If the angles of a triangle are in the ratio 4 : 1 : 1, then the ratio of the longest side to the perimeter is (2003, 1M)

- (a) $\sqrt{3} : (2 + \sqrt{3})$ (b) 1 : 3 : 2
(c) 1 : 2 + $\sqrt{3}$ (d) 2 : 3

8. In a $\triangle ABC$, $2ac\sin\left[\frac{1}{2}(A-B+C)\right]$ is equal to (2000, 2M)

- (a) $a^2 + b^2 - c^2$ (b) $c^2 + a^2 - b^2$
(c) $b^2 - c^2 - a^2$ (d) $c^2 - a^2 - b^2$

9. In a $\triangle PQR$, $\angle R = \frac{\pi}{2}$, if $\tan\left(\frac{P}{2}\right)$ and $\tan\left(\frac{Q}{2}\right)$ are the roots of the equation $ax^2 + bx + c = 0$ ($a \neq 0$), then

- (a) $a + b = c$ (b) $b + c = a$ (1999, 2M)
(c) $a + c = b$ (d) $b = c$

10. If in a $\triangle PQR$, $\sin P, \sin Q, \sin R$ are in AP, then (1998, 2M)

- (a) the altitudes are in AP
(b) the altitudes are in HP
(c) the medians are in GP
(d) the medians are in AP

11. In a $\triangle ABC$, $\angle B = \frac{\pi}{3}$ and $\angle C = \frac{\pi}{4}$. Let D divides BC internally in the ratio 1 : 3, then $\frac{\sin\angle BAD}{\sin\angle CAD}$ is equal to (1995, 2M)

- (a) $\frac{1}{\sqrt{6}}$ (b) $\frac{1}{3}$
(c) $\frac{1}{\sqrt{3}}$ (d) $\frac{\sqrt{2}}{\sqrt{3}}$

Objective Questions II

(One or more than one correct option)

12. In a ΔPQR , P is the largest angle and $\cos P = \frac{1}{3}$. Further in circle of the triangle touches the sides PQ, QR and RP at N, L and M respectively, such that the lengths of PN, QL and RM are consecutive even integers. Then, possible length(s) of the side(s) of the triangle is (are) (2017 Main)
- (a) 16 (b) 18 (c) 24 (d) 22
13. Let ABC be a triangle such that $\angle ACB = \frac{\pi}{6}$. If a, b and c denote the lengths of the sides opposite to A, B and C respectively. Then, the value(s) of x for which $a = x^2 + x + 1, b = x^2 - 1$ and $c = 2x + 1$ is (are) (2010)
- (a) $-(2 + \sqrt{3})$ (b) $1 + \sqrt{3}$ (c) $2 + \sqrt{3}$ (d) $4\sqrt{3}$
14. In a ΔABC with fixed base BC , the vertex A moves such that $\cos B + \cos C = 4 \sin^2 \frac{A}{2}$. If a, b and c denote the lengths of the sides of the triangle opposite to the angles A, B and C respectively, then (2009)
- (a) $b + c = 4a$ (b) $b + c = 2a$
 (c) locus of point A is an ellipse
 (d) locus of point A is a pair of straight line
15. Internal bisector of $\angle A$ of ΔABC meets side BC at D . A line drawn through D perpendicular to AD intersects the side AC at E and side AB at F . If a, b, c represent sides of ΔABC , then (2006, 5M)
- (a) AE is HM of b and c (b) $AD = \frac{2bc}{b+c} \cos \frac{A}{2}$
 (c) $EF = \frac{4bc}{b+c} \sin \frac{A}{2}$ (d) ΔAEF is isosceles
16. There exists a ΔABC satisfying the conditions (1986, 2M)
- (a) $b \sin A = a, A < \frac{\pi}{2}$ (b) $b \sin A > a, A > \frac{\pi}{2}$
 (c) $b \sin A > a, A < \frac{\pi}{2}$ (d) $b \sin A < a, A < \frac{\pi}{2}, b > a$

Fill in the Blanks

17. In a ΔABC , AD is the altitude from A . Given $b > c, \angle C = 23^\circ$ and $AD = \frac{abc}{b^2 - c^2}$, then $\angle B = \dots$ (1994, 2M)
18. If in a ΔABC , $\frac{2 \cos A}{a} + \frac{\cos B}{b} + \frac{2 \cos C}{c} = \frac{a}{bc} + \frac{b}{ca}$. Then, the value of the $\angle A$ is (1993, 2M)

Analytical & Descriptive Questions

19. Let A_1, A_2, \dots, A_n be the vertices of an n -sided regular polygon such that $\frac{1}{A_1 A_2} = \frac{1}{A_1 A_3} + \frac{1}{A_1 A_4}$. Find the value of n . (1994, 4M)
20. The sides of a triangle are three consecutive natural numbers and its largest angle is twice the smallest one. Determine the sides of the triangle. (1991, 4M)
21. In a ΔABC , the median to the side BC is of length $\frac{1}{\sqrt{11 - 6\sqrt{3}}}$ and it divides the $\angle A$ into angles 30° and 45° . Find the length of the side BC . (1985, 5M)
22. With usual notation, if in a ΔABC $\frac{b+c}{11} = \frac{c+a}{12} = \frac{a+b}{13}$, then prove that $\frac{\cos A}{7} = \frac{\cos B}{19} = \frac{\cos C}{25}$. (1984, 4M)
23. ABC is a triangle. D is the middle point of BC . If AD is perpendicular to AC , then prove that $\cos A \cos C = \frac{2(c^2 - a^2)}{3ac}$. (1980, 3M)
24. If in a triangle $ABC, a = 1 + \sqrt{3}$ cm, $b = 2$ cm and $\angle C = 60^\circ$, then find the other two angles and the third side. (1978, 3M)

Topic 2 Applications of Area, Napier's Analogy and Solution of a Triangle

Objective Questions I (Only one correct option)

1. With the usual notation, in ΔABC , if $\angle A + \angle B = 120^\circ, a = \sqrt{3} + 1$ and $b = \sqrt{3} - 1$, then the ratio $\angle A : \angle B$, is (2019 Main, 10 Jan II)
- (a) 7:1 (b) 3:1
 (c) 9:7 (d) 5:3
2. If PQR is a triangle of area Δ with $a = 2, b = \frac{7}{2}$ and $c = \frac{5}{2}$, where a, b and c are the lengths of the sides of

- the triangle opposite to the angles at P, Q and R , respectively. Then, $\frac{2 \sin P - \sin 2P}{2 \sin P + \sin 2P}$ equals (2012)
- (a) $\frac{3}{4\Delta}$ (b) $\frac{45}{4\Delta}$ (c) $\left(\frac{3}{4\Delta}\right)^2$ (d) $\left(\frac{45}{4\Delta}\right)^5$
3. In radius of a circle which is inscribed in a isosceles triangle one of whose angle is $2\pi/3$, is $\sqrt{3}$, then area of triangle (in sq units) is (2006, 2M)
- (a) $4\sqrt{3}$ (b) $12 - 7\sqrt{3}$
 (c) $12 + 7\sqrt{3}$ (d) None of these

528 Properties of Triangles

4. The sides of a triangle are in the ratio $1:\sqrt{3}:2$, then the angles of the triangle are in the ratio (2004, 1M)
 (a) $1:3:5$ (b) $2:3:2$ (c) $3:2:1$ (d) $1:2:3$

Objective Questions II

(One or more than one correct option)

5. Let x, y and z be positive real numbers. Suppose x, y and z are the lengths of the sides of a triangle opposite to its angles X, Y and Z , respectively. If

$$\tan \frac{X}{2} + \tan \frac{Z}{2} = \frac{2y}{x+y+z},$$

then which of the following statements is/are TRUE?

- (a) $2Y = X + Z$ (b) $Y = X + Z$ (2020 Adv.)
 (c) $\tan \frac{X}{2} = \frac{x}{y+z}$ (d) $x^2 + z^2 - y^2 = xz$

Fill in the Blank

6. If the angle of a triangle are 30° and 45° and the included side is $(\sqrt{3} + 1)$ cm, then the area of the triangle is ... (1988, 2M)
 7. The set of all real numbers a such that $a^2 + 2a, 2a + 3$ and $a^2 + 3a + 8$ are the sides of a triangle is (1985, 2M)

Analytical & Descriptive Questions

8. If Δ is the area of a triangle with side lengths a, b, c , then show that

$$\Delta \leq \frac{1}{4} \sqrt{(a+b+c)abc}$$

Also, show that the equality occurs in the above inequality if and only if $a = b = c$. (2001, 6M)

9. Prove that a ΔABC is equilateral if and only if $\tan A + \tan B + \tan C = 3\sqrt{3}$. (1998, 8M)
 10. Show that for any triangle with sides a, b, c
 $3(ab + bc + ca) \leq (a + b + c)^2 \leq 4(ab + bc + ca)$. (1979, 3M)

11. Let A, B, C be three angles such that $A = \frac{\pi}{4}$ and $\tan B, \tan C = p$. Find all positive values of p such that A, B, C are the angles of triangle. (1997C, 5M)

12. Consider the following statements concerning a ΔABC

- (i) The sides a, b, c and area of triangle are rational.
 (ii) $a, \tan \frac{B}{2}, \tan \frac{C}{2}$ are rational.
 (iii) $a, \sin A, \sin B, \sin C$ are rational.

Prove that (i) \Rightarrow (ii) \Rightarrow (iii) \Rightarrow (i) (1994, 5M)

13. In a triangle of base a , the ratio of the other two sides is $r (< 1)$. Show that the altitude of the triangle is less than or equal to $\frac{ar}{1-r^2}$. (1991, 4M)

14. If in a ΔABC , $\cos A \cos B + \sin A \sin B \sin C = 1$, then show that $a : b : c = 1 : 1 : \sqrt{2}$. (1986, 5M)

15. For a ΔABC , it is given that $\cos A + \cos B + \cos C = \frac{3}{2}$. Prove that the triangle is equilateral. (1984, 4M)

16. If p_1, p_2, p_3 are the altitudes of a triangle from the vertices A, B, C and Δ is the area of the triangle, then prove that

$$\frac{1}{p_1} + \frac{1}{p_2} - \frac{1}{p_3} = \frac{2ab}{(a+b+c)\Delta} \cos^2 \frac{C}{2} \quad (1978, 3M)$$

17. If p_1, p_2, p_3 are the perpendiculars from the vertices of a triangle to the opposite sides, then prove that

$$p_1 p_2 p_3 = \frac{a^2 b^2 c^2}{8R^3} \quad (1978, 3M)$$

Integer & Numerical Answer Type Question

18. Let ABC and ABC' be two non-congruent triangles with sides $AB = 4, AC = AC' = 2\sqrt{2}$ and angle $B = 30^\circ$. The absolute value of the difference between the areas of these triangles is (2009)

Topic 3 Circumcircle, Incircle, Escribed, Orthocentre and Centroid of a Triangle

Objective Questions I (Only one correct option)

1. Two vertices of a triangle are $(0, 2)$ and $(4, 3)$. If its orthocentre is at the origin, then its third vertex lies in which quadrant? (2019 Main, 10 Jan II)
 (a) Fourth (b) Third
 (c) Second (d) First

2. Let the equations of two sides of a triangle be $3x - 2y + 6 = 0$ and $4x + 5y - 20 = 0$. If the orthocentre of this triangle is at $(1, 1)$ then the equation of its third side is (2019 Main, 9 Jan II)
 (a) $122y - 26x - 1675 = 0$ (b) $26x - 122y - 1675 = 0$
 (c) $122y + 26x + 1675 = 0$ (d) $26x + 61y + 1675 = 0$

3. In a triangle, the sum of two sides is x and the product of the same two sides is y . If $x^2 - c^2 = y$, where c is the third side of the triangle, then the ratio of the inradius to the circumradius of the triangle is (2014 Adv.)
- (a) $\frac{3y}{2x(x+c)}$ (b) $\frac{3y}{2c(x+c)}$
 (c) $\frac{3y}{4x(x+c)}$ (d) $\frac{3y}{4c(x+c)}$
4. Which of the following pieces of data does not uniquely determine an acute angled $\triangle ABC$ (R being the radius of the circumcircle)? (2002, 1M)
- (a) $a, \sin A, \sin B$ (b) a, b, c
 (c) $a, \sin B, R$ (d) $a, \sin A, R$
5. In a $\triangle ABC$, let $\angle C = \pi/2$. If r is the inradius and R is the circumradius of the triangle, then $2(r+R)$ is equal to (2000, 2M)
- (a) $a+b$ (b) $b+c$ (c) $c+a$ (d) $a+b+c$

Passage Based Problems

Consider the circle $x^2 + y^2 = 9$ and the parabola $y^2 = 8x$. They intersect at P and Q in the first and the fourth quadrants, respectively. Tangents to the circle at P and Q intersect the X -axis at R and tangents to the parabola at P and Q intersect the X -axis at S . (2007, 8M)

6. The radius of the incircle of $\triangle PQR$ is
 (a) 4 (b) 3 (c) $\frac{8}{3}$ (d) 2
7. The radius of the circumcircle of the $\triangle PRS$ is
 (a) 5 (b) $3\sqrt{3}$ (c) $3\sqrt{2}$ (d) $2\sqrt{3}$
8. The ratio of the areas of $\triangle PQS$ and $\triangle PQR$ is
 (a) $1:\sqrt{2}$ (b) $1:2$
 (c) $1:4$ (d) $1:8$

Objective Questions II

(One or more than one correct option)

9. In a non-right-angled triangle $\triangle PQR$, let p, q, r denote the lengths of the sides opposite to the angles at P, Q, R respectively. The median from R meets the side PQ at S , the perpendicular from P meets the side QR at E , and RS and PE intersect at O . If $p = \sqrt{3}$, $q = 1$, and the radius of the circumcircle of the $\triangle PQR$ equals 1, then which of the following options is/are correct? (2019 Adv.)
- (a) Length of $OE = \frac{1}{6}$
 (b) Length of $RS = \frac{\sqrt{7}}{2}$
 (c) Area of $\triangle SOE = \frac{\sqrt{3}}{12}$
 (d) Radius of incircle of $\triangle PQR = \frac{\sqrt{3}}{2} (2 - \sqrt{3})$

10. In a $\triangle PQR$, let $\angle PQR = 30^\circ$ and the sides PQ and QR have lengths $10\sqrt{3}$ and 10, respectively. Then, which of the following statement(s) is (are) TRUE? (2018 Adv.)
- (a) $\angle QPR = 45^\circ$
 (b) The area of the $\triangle PQR$ is $25\sqrt{3}$ and $\angle QRP = 120^\circ$
 (c) The radius of the incircle of the $\triangle PQR$ is $10\sqrt{3} - 15$
 (d) The area of the circumcircle of the $\triangle PQR$ is 100π
11. In a $\triangle XYZ$, let x, y, z be the lengths of sides opposite to the angles X, Y, Z respectively and $2s = x + y + z$. If $\frac{s-x}{4} = \frac{s-y}{3} = \frac{s-z}{2}$ and area of incircle of the $\triangle XYZ$ is $\frac{8\pi}{3}$, then (2016 Adv.)
- (a) area of the $\triangle XYZ$ is $6\sqrt{6}$
 (b) the radius of circumcircle of the $\triangle XYZ$ is $\frac{35\sqrt{6}}{6}$
 (c) $\sin \frac{X}{2} \sin \frac{Y}{2} \sin \frac{Z}{2} = \frac{4}{35}$
 (d) $\sin^2 \left(\frac{X+Y}{2} \right) = \frac{3}{5}$
12. A straight line through the vertex P of a $\triangle PQR$ intersects the side QR at the point S and the circumcircle of the $\triangle PQR$ at the point T . If S is not the centre of the circumcircle, then (2008, 4M)
- (a) $\frac{1}{PS} + \frac{1}{ST} < \frac{2}{\sqrt{QS \times SR}}$
 (b) $\frac{1}{PS} + \frac{1}{ST} > \frac{2}{\sqrt{QS \times SR}}$
 (c) $\frac{1}{PS} + \frac{1}{ST} < \frac{4}{QR}$
 (d) $\frac{1}{PS} + \frac{1}{ST} > \frac{4}{QR}$

Fill in the Blanks

13. In a $\triangle ABC$, $a : b : c = 4 : 5 : 6$. The ratio of radius of the circumcircle to that of the incircle is... (1996, 1M)
14. The sides of a triangle inscribed in a given circle subtend angles α, β and γ at the centre. The minimum value of the arithmetic mean of $\cos \left(\alpha + \frac{\pi}{2} \right), \cos \left(\beta + \frac{\pi}{2} \right)$ and $\cos \left(\gamma + \frac{\pi}{2} \right)$ is (1987, 2M)
15. A polygon of nine sides, each of length 2, is inscribed in a circle. The radius of the circle is... (1987, 2M)

Analytical & Descriptive Questions

16. Circle with radii 3, 4 and 5 touch each other externally, if P is the point of intersection of tangents to these circles at their points of contact. Find the distance of P from the point of contact. (2005, 2M)
17. I_n is the area of n sided regular polygon inscribed in a circle of unit radius and O_n be the area of the polygon circumscribing the given circle, prove that

$$I_n = \frac{O_n}{2} \left(1 + \sqrt{1 - \left(\frac{2I_n}{n} \right)^2} \right). \quad (2003, 5M)$$

530 Properties of Triangles

18. Let ABC be a triangle with incentre I and inradius r . Let D, E, F be the feet of the perpendiculars from I to the sides BC, CA and AB , respectively. If r_1, r_2 and r_3 are the radii of circles inscribed in the quadrilaterals $AFIE, BDIF$ and $CEID$ respectively, then prove that

$$\frac{r_1}{r-r_1} + \frac{r_2}{r-r_2} + \frac{r_3}{r-r_3} = \frac{r_1 r_2 r_3}{(r-r_1)(r-r_2)(r-r_3)}. \quad (2000, 3M)$$

19. Let ABC be a triangle having O and I as its circumcentre and incentre, respectively. If R and r are the circumradius and the inradius respectively, then prove that $(IO)^2 = R^2 - 2Rr$. Further show that

the ΔBIO is a right angled triangle if and only if b is the arithmetic mean of a and c . (1999, 10M)

20. The exradii r_1, r_2, r_3 of ΔABC are in HP, show that its sides a, b, c are in AP. (1983, 3M)

Integer & Numerical Answer Type Question

21. Consider a ΔABC and let a, b and c denote the lengths of the sides opposite to vertices A, B and C , respectively. $a = 6, b = 10$ and the area of the triangle is $15\sqrt{3}$. If $\angle ACB$ is obtuse and if r denotes the radius of the incircle of the triangle, then r^2 is equal to.....

Answers

Topic 1

1. (c) 2. (d) 3. (b) 4. (a)
 5. (d) 6. (d) 7. (a) 8. (b)
 9. (a) 10. (b) 11. (a) 12. (b, d)
 13. (b) 14. (b, c) 15. (a, b, c, d) 16. (a, d)
 17. 113° 18. 90° 19. $n = 7$ 20. 4, 5, 6 units
 21. 2 24. $C = \sqrt{6}, \angle B = 45^\circ$ and $\angle A = 75^\circ$

Topic 2

1. (a) 2. (c) 3. (c) 4. (d)
 5. (c) 6. $\frac{1+\sqrt{3}}{2}$ sq cm 7. $a > 5$

11. $p \in (-\infty, 0) \cup [3 + 2\sqrt{2}, \infty)$

18. 4 sq units

Topic 3

1. (c) 2. (b) 3. (b) 4. (c)
 5. (a) 6. (d) 7. (b) 8. (c)
 9. (a,b,d) 10. (b,c,d) 11. (a,c,d) 12. (b,d)
 13. $\frac{16}{7}$ 14. $-\frac{\sqrt{3}}{2}$ 15. $\operatorname{cosec} 20^\circ$ 16. $\sqrt{5}$
 21. 3

Hints & Solutions

Topic 1 Applications of Sine, Cosine, Projection and Half Angle Formulae

1. It is given that angles of a ΔABC are in AP.

So, $\angle A + \angle B + \angle C = 180^\circ$

$\Rightarrow \angle B - d + \angle B + \angle B + d = 180^\circ$

[if $\angle A, \angle B$ and $\angle C$ are in AP, then it taken as $\angle B - d, \angle B, \angle B + d$ respectively, where d is common difference of AP]

$\Rightarrow 3\angle B = 180^\circ \Rightarrow \angle B = 60^\circ \quad \dots(i)$

and $\frac{a}{b} = \frac{1}{\sqrt{3}} \quad [\text{given}]$

$\Rightarrow \frac{\sin A}{\sin B} = \frac{1}{\sqrt{3}}$

$\left[\text{by sine rule } \frac{\sin A}{a} = \frac{\sin B}{b} = \frac{\sin C}{c} \right]$

$\Rightarrow \frac{\sin A}{\frac{1}{\sqrt{3}}} = \frac{1}{\sqrt{3}} \quad \left[\because \sin B = \sin 60^\circ = \frac{\sqrt{3}}{2} \right]$

$\Rightarrow \sin A = \frac{1}{2} \Rightarrow \angle A = 30^\circ$

So, $\angle C = 90^\circ$

\therefore From sine rule,

$$\frac{a}{\sin A} = \frac{b}{\sin B} = \frac{c}{\sin C}$$

$\Rightarrow \frac{a}{\frac{1}{2}} = \frac{b}{\frac{\sqrt{3}}{2}} = \frac{4}{1} \quad [\because c = 4 \text{ cm}]$

$\Rightarrow a = 2 \text{ cm}, b = 2\sqrt{3} \text{ cm}$

\therefore Area of $\Delta ABC = \frac{1}{2} ab \sin C = \frac{1}{2} \times 2 \times 2\sqrt{3} \times 1 = 2\sqrt{3} \text{ sq cm}$

2. Given, $\frac{b+c}{11} = \frac{c+a}{12} = \frac{a+b}{13} = \lambda$ (say)

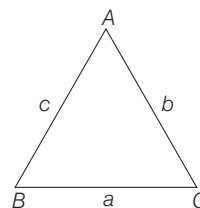

$b + c = 11\lambda, c + a = 12\lambda$ and $a + b = 13\lambda \quad \dots(ii)$

$$\Rightarrow 2(a + b + c) = 36\lambda$$

$$\Rightarrow a + b + c = 18\lambda$$

From Eqs. (i) and (ii), we get

$$a = 7\lambda, b = 6\lambda, c = 5\lambda$$

Now,

$$\cos A = \frac{b^2 + c^2 - a^2}{2bc} = \frac{\lambda^2[36 + 25 - 49]}{60\lambda^2} = \frac{12}{60} = \frac{1}{5}$$

$$\cos B = \frac{a^2 + c^2 - b^2}{2ac} = \frac{\lambda^2[49 + 25 - 36]}{70\lambda^2} = \frac{19}{35}$$

$$\begin{aligned} \text{and } \cos C &= \frac{a^2 + b^2 - c^2}{2ab} \\ &= \frac{\lambda^2[49 + 36 - 25]}{84\lambda^2} \\ &= \frac{60}{84} = \frac{5}{7} \end{aligned}$$

$$\text{Thus, } \cos A = \frac{1}{5} = \frac{7}{35},$$

$$\cos B = \frac{19}{35}, \cos C = \frac{25}{35}$$

$$\frac{\cos A}{7} = \frac{\cos B}{19} = \frac{\cos C}{25} = \frac{1}{35}$$

$$\Rightarrow (\alpha, \beta, \gamma) = (7, 19, 25)$$

3. We know that, $\frac{a}{\sin A} = \frac{b}{\sin B} = \frac{c}{\sin C} = 2R$

and given that, $a + b = x, ab = y$ and $x^2 - c^2 = y$

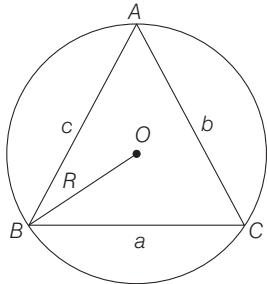

$$\begin{aligned} \therefore (a + b)^2 - c^2 &= ab \\ \Rightarrow a^2 + b^2 - c^2 &= -2ab + ab \\ \Rightarrow a^2 + b^2 - c^2 &= -ab \\ \Rightarrow \frac{a^2 + b^2 - c^2}{2ab} &= \frac{-ab}{2ab} = -\frac{1}{2} \end{aligned}$$

$$\therefore \cos C = -\frac{1}{2}$$

$$\Rightarrow C = 120^\circ$$

[using cosine rule, $\cos C = \frac{a^2 + b^2 - c^2}{2ab}$]

$$\text{Now, } \frac{c}{\sin C} = 2R$$

$$\Rightarrow R = \frac{1}{2} \frac{c}{\sin(120^\circ)} = \frac{c}{2\sqrt{3}}$$

$$\therefore R = \frac{c}{\sqrt{3}}$$

...(ii)

4. Applying sine rule in $\triangle ABD$,

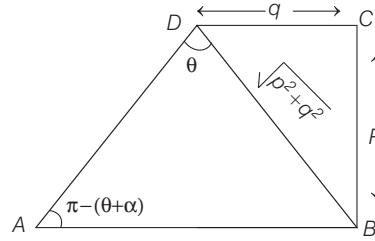

$$\frac{AB}{\sin \theta} = \frac{\sqrt{p^2 + q^2}}{\sin \{\pi - (\theta + \alpha)\}}$$

$$\Rightarrow \frac{AB}{\sin \theta} = \frac{\sqrt{p^2 + q^2}}{\sin(\theta + \alpha)}$$

$$\begin{aligned} \Rightarrow AB &= \frac{\sqrt{p^2 + q^2} \sin \theta}{\sin \theta \cos \alpha + \cos \theta \sin \alpha} \quad \left[\because \cos \alpha = \frac{q}{\sqrt{p^2 + q^2}} \right] \\ &= \frac{(p^2 + q^2) \sin \theta}{p \cos \theta + q \sin \theta} \quad \text{and } \sin \alpha = \frac{p}{\sqrt{p^2 + q^2}} \end{aligned}$$

Alternate Solution

Let $AB = x$

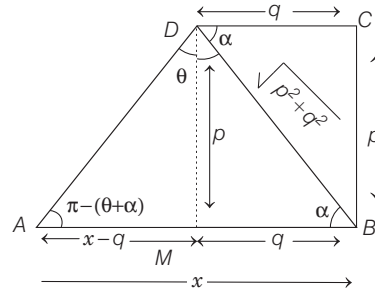

$$\text{In } \triangle DAM, \tan(\pi - \theta - \alpha) = \frac{p}{x - q}$$

$$\Rightarrow \tan(\theta + \alpha) = \frac{p}{q - x}$$

$$\Rightarrow q - x = p \cot(\theta + \alpha)$$

$$\Rightarrow x = q - p \cot(\theta + \alpha)$$

$$= q - p \left(\frac{\cot \theta \cot \alpha - 1}{\cot \alpha + \cot \theta} \right) \quad \left[\because \cot \alpha = \frac{q}{p} \right]$$

$$= q - p \left(\frac{\frac{q}{p} \cot \theta - 1}{\frac{q}{p} + \cot \theta} \right) = q - p \left(\frac{q \cot \theta - p}{q + p \cot \theta} \right)$$

$$= q - p \left(\frac{q \cos \theta - p \sin \theta}{q \sin \theta + p \cos \theta} \right)$$

$$\Rightarrow x = \frac{q^2 \sin \theta + pq \cos \theta - pq \cos \theta + p^2 \sin \theta}{p \cos \theta + q \sin \theta}$$

$$\Rightarrow AB = \frac{(p^2 + q^2) \sin \theta}{p \cos \theta + q \sin \theta}$$

532 Properties of Triangles

5. Since, A, B, C are in AP.

$$\Rightarrow 2B = A + C \text{ i.e. } \angle B = 60^\circ$$

$$\begin{aligned} \therefore \frac{a}{c} (2 \sin C \cos C) + \frac{c}{a} (2 \sin A \cos A) \\ &= 2k (a \cos C + c \cos A) \\ &\left[\text{using, } \frac{a}{\sin A} = \frac{b}{\sin B} = \frac{c}{\sin C} = \frac{1}{k} \right] \\ &= 2k(b) \\ &= 2 \sin B \quad [\text{using } b = a \cos C + c \cos A] \\ &= \sqrt{3} \end{aligned}$$

6. Let a, b, c are the sides of $\triangle ABC$.

$$\text{Now, } \frac{b+c}{a} = \frac{k(\sin B + \sin C)}{k \sin A} \quad [\text{by sine rule}]$$

$$= \frac{2 \sin \left(\frac{B+C}{2} \right) \cos \left(\frac{B-C}{2} \right)}{2 \sin \frac{A}{2} \cos \frac{A}{2}} \Rightarrow \frac{b+c}{a} = \frac{\cos \left(\frac{B-C}{2} \right)}{\sin \frac{A}{2}}$$

$$\text{Also, } \frac{b-c}{a} = \frac{\sin \left(\frac{B-C}{2} \right)}{\cos \frac{A}{2}}$$

$$\text{or } (b-c) \cos \frac{A}{2} = a \sin \left(\frac{B-C}{2} \right)$$

7. Given, ratio of angles are 4 : 1 : 1.

$$\begin{aligned} \Rightarrow 4x + x + x &= 180^\circ \Rightarrow x = 30^\circ \\ \therefore \angle A &= 120^\circ, \angle B = \angle C = 30^\circ \end{aligned}$$

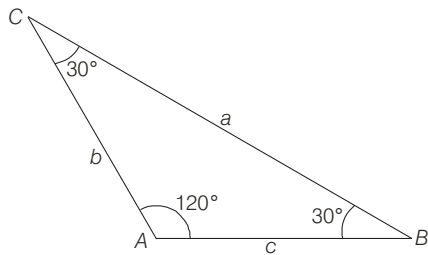

$$\text{Thus, ratio of longest side to perimeter} = \frac{a}{a+b+c}$$

$$\begin{aligned} \text{Let } b &= c = x \\ \Rightarrow a^2 &= b^2 + c^2 - 2bc \cos A \quad [\text{by cosine rule}] \\ \Rightarrow a^2 &= 2x^2 - 2x^2 \cos A \\ &= 2x^2(1 - \cos A) \\ \Rightarrow a^2 &= 4x^2 \sin^2 A/2 \\ \Rightarrow a &= 2x \sin A/2 \Rightarrow a = 2x \sin 60^\circ = \sqrt{3}x \end{aligned}$$

Thus, required ratio

$$\begin{aligned} &= \frac{a}{a+b+c} = \frac{\sqrt{3}x}{x+x+\sqrt{3}x} \\ &= \frac{\sqrt{3}}{2+\sqrt{3}} = \sqrt{3} : 2 + \sqrt{3} \end{aligned}$$

8. We know that, $A + B + C = 180^\circ$

$$\Rightarrow A + C - B = 180 - 2B$$

$$\begin{aligned} \text{Now, } 2ac \sin \left[\frac{1}{2} (A - B + C) \right] &= 2ac \sin (90^\circ - B) \\ &= 2ac \cos B = \frac{2ac \cdot (a^2 + c^2 - b^2)}{2ac} \quad [\text{by cosine rule}] \\ &= a^2 + c^2 - b^2 \end{aligned}$$

9. It is given that, $\tan (P/2)$ and $\tan (Q/2)$ are the roots of the quadratic equation $ax^2 + bx + c = 0$

$$\text{and } \angle R = \pi/2$$

$$\therefore \tan (P/2) + \tan (Q/2) = -b/a$$

$$\text{and } \tan (P/2) \tan (Q/2) = c/a$$

$$\text{Since, } P + Q + R = 180^\circ$$

$$\Rightarrow P + Q = 90^\circ$$

$$\Rightarrow \frac{P+Q}{2} = 45^\circ$$

$$\Rightarrow \tan \left(\frac{P+Q}{2} \right) = \tan 45^\circ$$

$$\Rightarrow \frac{\tan (P/2) + \tan (Q/2)}{1 - \tan (P/2) \tan (Q/2)} = 1$$

$$\Rightarrow \frac{-b/a}{1 - c/a} = 1$$

$$\Rightarrow \frac{-b/a}{a-c} = 1$$

$$\Rightarrow \frac{-b}{a-c} = 1$$

$$\Rightarrow -b = a - c$$

$$\Rightarrow a + b = c$$

10. By the law of sine rule,

$$\frac{a}{\sin P} = \frac{b}{\sin Q} = \frac{c}{\sin R} = k \quad [\text{say}]$$

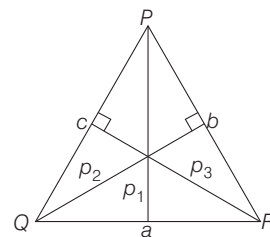

$$\text{Also, } \frac{1}{2} ap_1 = \Delta$$

$$\Rightarrow \frac{2\Delta}{a} = p_1$$

$$\Rightarrow p_1 = \frac{2\Delta}{k \sin P}$$

$$\text{Similarly, } p_2 = \frac{2\Delta}{k \sin Q} \text{ and } p_3 = \frac{2\Delta}{k \sin R}$$

Since, $\sin P, \sin Q$ and $\sin R$ are in AP, hence p_1, p_2, p_3 are in HP.

11. In $\triangle ABD$, applying sine rule, we get

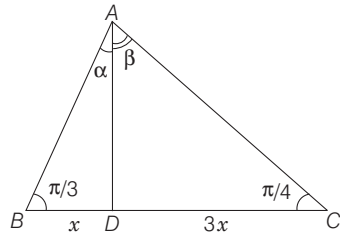

$$\frac{AD}{\sin \pi/3} = \frac{x}{\sin \alpha}$$

$$\Rightarrow AD = \frac{\sqrt{3}}{2} x \sin \alpha \quad \dots(i)$$

and in $\triangle ACD$, applying sine rule, we get

$$\frac{AD}{\sin \pi/4} = \frac{3x}{\sin \beta}$$

$$\Rightarrow AD = \frac{3}{\sqrt{2}} x \sin \beta \quad \dots(ii)$$

From Eqs. (i) and (ii), $\frac{\sqrt{3}x}{2 \sin \alpha} = \frac{3x}{\sqrt{2} \sin \beta}$

$$\Rightarrow \frac{\sin \alpha}{\sin \beta} = \frac{1}{\sqrt{6}}$$

12. **PLAN** Whenever cosine of angle and sides are given or to find out, we should always use Cosine law.

i.e. $\cos A = \frac{b^2 + c^2 - a^2}{2bc}$, $\cos B = \frac{a^2 + c^2 - b^2}{2ac}$

and $\cos C = \frac{a^2 + b^2 - c^2}{2ab}$

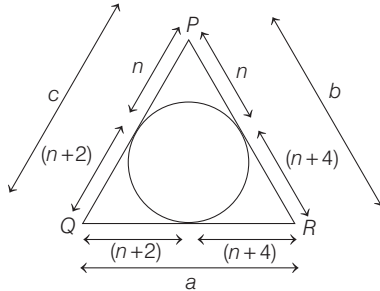

$$\therefore \cos P = \frac{b^2 + c^2 - a^2}{2bc}$$

$$\Rightarrow \frac{1}{3} = \frac{(2n+4)^2 + (2n+2)^2 - (2n+6)^2}{2(2n+4)(2n+2)}$$

[$\because \cos p = \frac{1}{3}$, given]

$$\Rightarrow \frac{4n^2 - 16}{8(n+1)(n+2)} = \frac{1}{3}$$

$$\Rightarrow \frac{n^2 - 4}{2(n+1)(n+2)} = \frac{1}{3}$$

$$\Rightarrow \frac{(n-2)}{2(n+1)} = \frac{1}{3}$$

$$\Rightarrow 3n - 6 = 2n + 2 \Rightarrow n = 8$$

\therefore Sides are $(2n+2)$, $(2n+4)$, $(2n+6)$, i.e. 18, 20, 22.

13. Using, $\cos C = \frac{a^2 + b^2 - c^2}{2ab}$

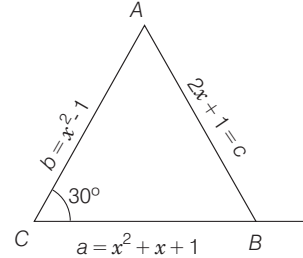

$$\Rightarrow \frac{\sqrt{3}}{2} = \frac{(x^2 + x + 1)^2 + (x^2 - 1)^2 - (2x + 1)^2}{2(x^2 + x + 1)(x^2 - 1)}$$

$$\Rightarrow (x+2)(x+1)(x-1)x + (x^2 - 1)^2 = \sqrt{3}(x^2 + x + 1)(x^2 - 1)$$

$$\Rightarrow x^2 + 2x + (x^2 - 1) = \sqrt{3}(x^2 + x + 1)$$

$$\Rightarrow (2 - \sqrt{3})x^2 + (2 - \sqrt{3})x - (\sqrt{3} + 1) = 0$$

$$\Rightarrow x = -(2 + \sqrt{3})$$

and $x = 1 + \sqrt{3}$

But $x = -(2 + \sqrt{3})$

$\Rightarrow c$ is negative.

$\therefore x = 1 + \sqrt{3}$ is the only solution.

14. Given, $\cos B + \cos C = 4 \sin^2 \frac{A}{2}$

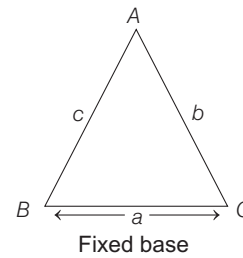

$$\Rightarrow 2 \cos \left(\frac{B+C}{2} \right) \cos \left(\frac{B-C}{2} \right) = 4 \sin^2 \frac{A}{2}$$

$$\Rightarrow 2 \sin \frac{A}{2} \left[\cos \left(\frac{B-C}{2} \right) - 2 \sin \frac{A}{2} \right] = 0$$

$$\Rightarrow \cos \left(\frac{B-C}{2} \right) - 2 \cos \left(\frac{B+C}{2} \right) = 0 \text{ as } \sin \frac{A}{2} \neq 0$$

$$\Rightarrow -\cos \frac{B}{2} \cos \frac{C}{2} + 3 \sin \frac{B}{2} \sin \frac{C}{2} = 0$$

$$\Rightarrow \tan \frac{B}{2} \tan \frac{C}{2} = \frac{1}{3}$$

$$\Rightarrow \sqrt{\frac{(s-a)(s-c)}{s(s-b)} \cdot \frac{(s-b)(s-a)}{s(s-c)}} = \frac{1}{3}$$

$$\Rightarrow \frac{s-a}{s} = \frac{1}{3}$$

$$\Rightarrow 2s = 3a$$

$$\Rightarrow b + c = 2a$$

\therefore Locus of A is an ellipse.

534 Properties of Triangles

15. Since, $\Delta ABC = \Delta ABD + \Delta ACD$

$$\Rightarrow \frac{1}{2} bc \sin A = \frac{1}{2} c AD \sin \frac{A}{2} + \frac{1}{2} b AD \sin \frac{A}{2}$$

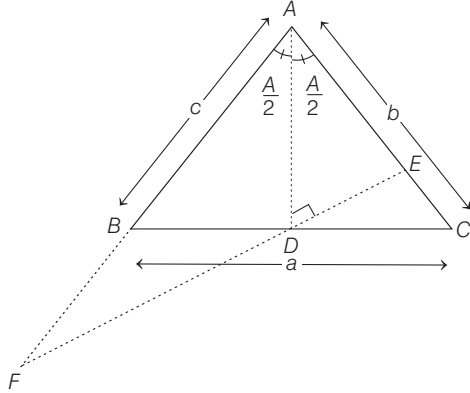

$$\Rightarrow AD = \frac{2bc}{b+c} \cos \frac{A}{2}$$

Again, $AE = AD \sec \frac{A}{2} = \frac{2bc}{b+c}$

$\Rightarrow AE$ is HM of b and c .

$$\begin{aligned} EF &= ED + DF = 2DE = 2AD \tan \frac{A}{2} \\ &= 2 \frac{2bc}{b+c} \cos \frac{A}{2} \tan \frac{A}{2} = \frac{4bc}{b+c} \sin \frac{A}{2} \end{aligned}$$

Since, $AD \perp EF$ and $DE = DF$ and AD is bisector.

$\Rightarrow \Delta AEF$ is isosceles.

Hence, (a), (b), (c), (d) are correct answers.

16. The sine formula is

$$\frac{a}{\sin A} = \frac{b}{\sin B}$$

$$\Rightarrow a \sin B = b \sin A$$

(a) $b \sin A = a \Rightarrow a \sin B = a$

$$\Rightarrow B = \frac{\pi}{2}$$

Since, $\angle A < \frac{\pi}{2}$, therefore the triangle is possible.

(b) and (c) $b \sin A > a$

$$\Rightarrow a \sin B > a$$

$$\Rightarrow \sin B > 1$$

$\therefore \Delta ABC$ is not possible.

(d) $b \sin A < a$

$$\Rightarrow a \sin B < a$$

$$\Rightarrow \sin B < 1$$

$$\Rightarrow \angle B \text{ exists.}$$

Now, $b > a$

$$\Rightarrow B > A$$

Since, $A < \frac{\pi}{2}$

\therefore The triangle is possible.

Hence, (a) and (d) are the correct answers.

17. In ΔADC , $\frac{AD}{b} = \sin 23^\circ$

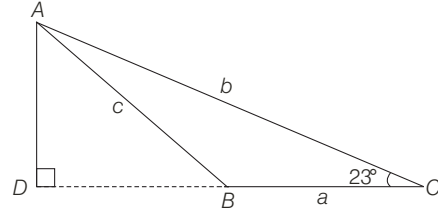

$$\Rightarrow AD = b \sin 23^\circ$$

But $AD = \frac{abc}{b^2 - c^2}$ [given]

$$\Rightarrow \frac{abc}{b^2 - c^2} = b \sin 23^\circ$$

$$\Rightarrow \frac{a}{b^2 - c^2} = \frac{\sin 23^\circ}{c} \quad \dots(i)$$

Again, in ΔABC ,

$$\frac{\sin A}{a} = \frac{\sin 23^\circ}{c}$$

$$\Rightarrow \frac{\sin A}{a} = \frac{a}{b^2 - c^2} \quad [\text{from Eq. (i)}]$$

$$\Rightarrow \sin A = \frac{a^2}{b^2 - c^2}$$

$$\Rightarrow \sin A = \frac{k^2 \sin^2 A}{k^2 \sin^2 B - k^2 \sin^2 C}$$

$$\Rightarrow \sin A = \frac{\sin^2 A}{\sin^2 B - \sin^2 C}$$

$$\Rightarrow \sin A = \frac{\sin^2 A}{\sin(B+C) \sin(B-C)}$$

$$\Rightarrow \sin A = \frac{\sin^2 A}{\sin A \cdot \sin(B-C)}$$

$$\Rightarrow \sin(B-C) = 1 \quad [\because \sin A \neq 0]$$

$$\Rightarrow \sin(B-23^\circ) = \sin 90^\circ$$

$$\Rightarrow B-23^\circ = 90^\circ$$

$$\therefore B = 113^\circ$$

18. Given, $\frac{2 \cos A}{a} + \frac{\cos B}{b} + \frac{2 \cos C}{c} = \frac{a}{bc} + \frac{b}{ca} \quad \dots(i)$

We know that, $\cos A = \frac{b^2 + c^2 - a^2}{2bc}$

$$\cos B = \frac{c^2 + a^2 - b^2}{2ac}$$

and $\cos C = \frac{a^2 + b^2 - c^2}{2ab}$

On putting these values in Eq. (i), we get

$$\begin{aligned} \frac{2(b^2 + c^2 - a^2)}{2abc} + \frac{c^2 + a^2 - b^2}{2abc} \\ + \frac{2(a^2 + b^2 - c^2)}{2abc} = \frac{a}{bc} + \frac{b}{ca} \end{aligned}$$

$$\begin{aligned} \Rightarrow \frac{2(b^2 + c^2 - a^2) + c^2 + a^2 - b^2 + 2(a^2 + b^2 - c^2)}{2abc} \\ = \frac{a^2 + b^2}{abc} \end{aligned}$$

$$\Rightarrow 3b^2 + c^2 + a^2 = 2a^2 + 2b^2 \Rightarrow b^2 + c^2 = a^2$$

Hence, the angle A is 90° .

19. Let O be the centre and r be the radius of the circle passing through the vertices A_1, A_2, \dots, A_n .

$$\text{Then, } \angle A_1 O A_2 = \frac{2\pi}{n}$$

$$\text{also } OA_1 = OA_2 = r$$

Again, by cos formula, we know that,

$$\cos\left(\frac{2\pi}{n}\right) = \frac{OA_1^2 + OA_2^2 - A_1 A_2^2}{2(OA_1)(OA_2)}$$

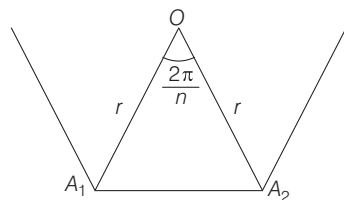

$$\Rightarrow \cos\left(\frac{2\pi}{n}\right) = \frac{r^2 + r^2 - A_1 A_2^2}{2(r)(r)}$$

$$\Rightarrow 2r^2 \cos\left(\frac{2\pi}{n}\right) = 2r^2 - A_1 A_2^2$$

$$\Rightarrow A_1 A_2^2 = 2r^2 - 2r^2 \cos\left(\frac{2\pi}{n}\right)$$

$$\Rightarrow A_1 A_2^2 = 2r^2 \left[1 - \cos\left(\frac{2\pi}{n}\right)\right]$$

$$\Rightarrow A_1 A_2^2 = 2r^2 \cdot 2 \sin^2\left(\frac{\pi}{n}\right)$$

$$\Rightarrow A_1 A_2^2 = 4r^2 \sin^2\left(\frac{\pi}{n}\right)$$

$$\Rightarrow A_1 A_2 = 2r \sin\left(\frac{\pi}{n}\right)$$

$$\text{Similarly, } A_1 A_3 = 2r \sin\left(\frac{2\pi}{n}\right)$$

$$\text{and } A_1 A_4 = 2r \sin\left(\frac{3\pi}{n}\right)$$

$$\text{Since, } \frac{1}{A_1 A_2} = \frac{1}{A_1 A_3} + \frac{1}{A_1 A_4} \quad [\text{given}]$$

$$\Rightarrow \frac{1}{2r \sin(\pi/n)} = \frac{1}{2r \sin(2\pi/n)} + \frac{1}{2r \sin(3\pi/n)}$$

$$\Rightarrow \frac{1}{\sin(\pi/n)} = \frac{1}{\sin(2\pi/n)} + \frac{1}{\sin(3\pi/n)}$$

$$\Rightarrow \frac{1}{\sin(\pi/n)} = \frac{\sin\left(\frac{3\pi}{n}\right) + \sin\left(\frac{2\pi}{n}\right)}{\sin(2\pi/n) \sin(3\pi/n)}$$

$$\begin{aligned} \Rightarrow \sin\left(\frac{2\pi}{n}\right) \cdot \sin\left(\frac{3\pi}{n}\right) &= \sin\left(\frac{\pi}{n}\right) \sin\left(\frac{3\pi}{n}\right) \\ &\quad + \sin\left(\frac{\pi}{n}\right) \cdot \sin\left(\frac{2\pi}{n}\right) \end{aligned}$$

$$\Rightarrow \sin\left(\frac{2\pi}{n}\right) \left[\sin\left(\frac{3\pi}{n}\right) - \sin\left(\frac{\pi}{n}\right) \right] = \sin\left(\frac{\pi}{n}\right) \cdot \sin\left(\frac{3\pi}{n}\right)$$

$$\begin{aligned} \Rightarrow \sin\left(\frac{2\pi}{n}\right) \left[\left\{ 2 \cos\left(\frac{3\pi + \pi}{2n}\right) \sin\left(\frac{3\pi - \pi}{2n}\right) \right\} \right] \\ = \sin\left(\frac{\pi}{n}\right) \sin\left(\frac{3\pi}{n}\right) \end{aligned}$$

$$\Rightarrow 2 \sin\left(\frac{2\pi}{n}\right) \cdot \cos\left(\frac{2\pi}{n}\right) \cdot \sin\left(\frac{\pi}{n}\right) = \sin\left(\frac{\pi}{n}\right) \sin\left(\frac{3\pi}{n}\right)$$

$$\Rightarrow 2 \sin\left(\frac{2\pi}{n}\right) \cos\left(\frac{2\pi}{n}\right) = \sin\left(\frac{3\pi}{n}\right)$$

$$\Rightarrow \sin\left(\frac{4\pi}{n}\right) = \sin\left(\frac{3\pi}{n}\right)$$

$$\Rightarrow \frac{4\pi}{n} = \pi - \frac{3\pi}{n}$$

$$\Rightarrow \frac{7\pi}{n} = \pi$$

$$\Rightarrow n = 7$$

20. Let ABC be the triangle such that the lengths of its sides CA, AB and BC are $(x-1), x$ and $(x+1)$ respectively, where $x \in \mathbb{N}$ and $x > 1$. Let $\angle B = \alpha$ be the smallest angle and $\angle A = 2\alpha$ be the largest angle.

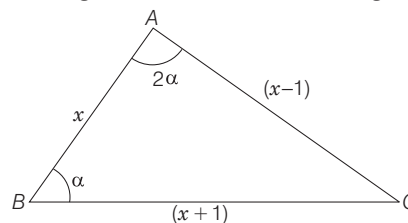

Then, by sine rule, we have

$$\begin{aligned} \frac{\sin \alpha}{x-1} &= \frac{\sin 2\alpha}{x+1} \\ \Rightarrow \frac{\sin 2\alpha}{\sin \alpha} &= \frac{x+1}{x-1} \\ \Rightarrow 2 \cos \alpha &= \frac{x+1}{x-1} \\ \therefore \cos \alpha &= \frac{x+1}{2(x-1)} \quad \dots(i) \end{aligned}$$

$$\text{Also, } \cos \alpha = \frac{x^2 + (x+1)^2 - (x-1)^2}{2x(x+1)} \quad [\text{using cosine law}]$$

$$\Rightarrow \cos \alpha = \frac{x+4}{2(x+1)} \quad \dots(ii)$$

From Eqs. (i) and (ii),

$$\frac{x+1}{2(x-1)} = \frac{x+4}{2(x+1)}$$

536 Properties of Triangles

$$\begin{aligned} \Rightarrow & (x+1)^2 = (x+4)(x-1) \\ \Rightarrow & x^2 + 2x + 1 = x^2 + 3x - 4 \\ \Rightarrow & x = 5 \end{aligned}$$

Hence, the lengths of the sides of the triangle are 4, 5 and 6 units.

21. Let AD be the median to the base $BC = a$ of $\triangle ABC$

and let $\angle ADC = \theta$, then

$$\begin{aligned} \left(\frac{a}{2} + \frac{a}{2}\right) \cot \theta &= \frac{a}{2} \cot 30^\circ - \frac{a}{2} \cot 45^\circ \\ \Rightarrow \cot \theta &= \frac{\sqrt{3} - 1}{2} \end{aligned}$$

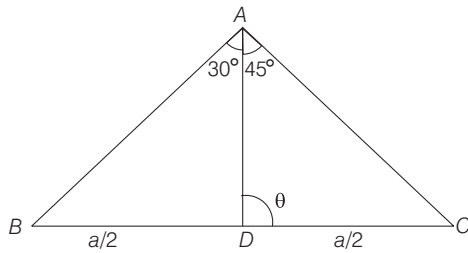

Applying sine rule in $\triangle ADC$, we get

$$\begin{aligned} \frac{AD}{\sin(\pi - \theta - 45^\circ)} &= \frac{DC}{\sin 45^\circ} \\ \Rightarrow \frac{AD}{\sin(\theta + 45^\circ)} &= \frac{\frac{a}{2}}{\frac{1}{\sqrt{2}}} \\ \Rightarrow AD &= \frac{a}{\sqrt{2}} (\sin 45^\circ \cos \theta + \cos 45^\circ \sin \theta) \\ \Rightarrow AD &= \frac{a}{\sqrt{2}} \left(\frac{\cos \theta + \sin \theta}{\sqrt{2}} \right) = \frac{a}{2} (\cos \theta + \sin \theta) \\ \Rightarrow \frac{1}{\sqrt{11 - 6\sqrt{3}}} &= \frac{a}{2} \left(\frac{\sqrt{3} - 1}{\sqrt{8 - 2\sqrt{3}}} + \frac{2}{\sqrt{8 - 2\sqrt{3}}} \right) \\ \Rightarrow a &= \frac{2\sqrt{8 - 2\sqrt{3}}}{(\sqrt{3} + 1)\sqrt{11 - 6\sqrt{3}}} = \frac{2\sqrt{8 - 2\sqrt{3}}}{\sqrt{(\sqrt{3} + 1)^2} \sqrt{11 - 6\sqrt{3}}} \\ &= \frac{2\sqrt{8 - 2\sqrt{3}}}{\sqrt{(4 + 2\sqrt{3})(11 - 6\sqrt{3})}} \\ &= \frac{2\sqrt{8 - 2\sqrt{3}}}{\sqrt{44 - 24\sqrt{3} + 22\sqrt{3} - 36}} \\ &= 2 \frac{\sqrt{8 - 2\sqrt{3}}}{\sqrt{8 - 2\sqrt{3}}} = 2 \end{aligned}$$

22. Let $\frac{b+c}{11} = \frac{c+a}{12} = \frac{a+b}{13} = \lambda$

$$\Rightarrow (b+c) = 11\lambda, c+a = 12\lambda, a+b = 13\lambda \quad \dots(i)$$

$$\Rightarrow 2(a+b+c) = 36\lambda$$

$$\Rightarrow a+b+c = 18\lambda \quad \dots(ii)$$

On solving Eqs. (i) and (ii), we get

$$\begin{aligned} a &= 7\lambda, b = 6\lambda \text{ and } c = 5\lambda \\ \cos A &= \frac{b^2 + c^2 - a^2}{2bc} = \frac{36\lambda^2 + 25\lambda^2 - 49\lambda^2}{2(30)\lambda^2} = \frac{1}{5} \\ \cos B &= \frac{a^2 + c^2 - b^2}{2ac} = \frac{49\lambda^2 + 25\lambda^2 - 36\lambda^2}{70\lambda^2} = \frac{19}{35} \\ \cos C &= \frac{a^2 + b^2 - c^2}{2ab} = \frac{49\lambda^2 + 36\lambda^2 - 25\lambda^2}{84\lambda^2} = \frac{5}{7} \end{aligned}$$

$$\therefore \cos A : \cos B : \cos C = \frac{1}{5} : \frac{19}{35} : \frac{5}{7} = 7:19:25$$

23. In $\triangle ADC$, we have

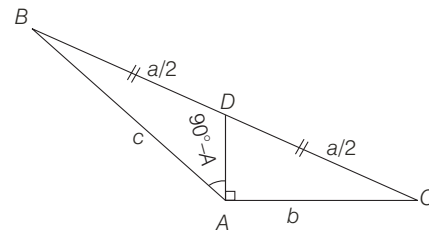

$$\begin{aligned} \cos C &= \frac{AC}{CD} \\ \cos C &= \frac{2b}{a} \quad \dots(i) \end{aligned}$$

Applying cosine formula in $\triangle ABC$, we have

$$\begin{aligned} \cos A &= \frac{b^2 + c^2 - a^2}{2bc} \\ \text{and } \cos C &= \frac{a^2 + b^2 - c^2}{2ab} \quad \dots(ii) \end{aligned}$$

From Eqs. (i) and (ii),

$$\begin{aligned} \frac{a^2 + b^2 - c^2}{2ab} &= \frac{2b}{a} \\ \Rightarrow a^2 + b^2 - c^2 &= 4b^2 \\ \Rightarrow a^2 - c^2 &= 3b^2 \quad \dots(iii) \end{aligned}$$

$$\begin{aligned} \text{Now, } \cos A \cos C &= \frac{b^2 + c^2 - a^2}{2bc} \cdot \frac{2b}{a} \\ &= \frac{b^2 + c^2 - a^2}{ac} = \frac{3b^2 + 3(c^2 - a^2)}{3ac} \\ &= \frac{(a^2 - c^2) + 3(c^2 - a^2)}{3ac} = \frac{2(c^2 - a^2)}{3ac} \end{aligned}$$

24. Given that,

$$a = 1 + \sqrt{3}, b = 2 \text{ and } \angle C = 60^\circ$$

We have, $c^2 = a^2 + b^2 - 2ab \cos C$

$$\Rightarrow c^2 = (1 + \sqrt{3})^2 + 4 - 2(1 + \sqrt{3}) \cdot 2 \cos 60^\circ$$

$$\Rightarrow c^2 = 1 + 2\sqrt{3} + 3 + 4 - 2 - 2\sqrt{3}$$

$$\Rightarrow c^2 = 6$$

$$\Rightarrow c = \sqrt{6}$$

Using sine rule,

$$\begin{aligned} \frac{a}{\sin A} &= \frac{b}{\sin B} = \frac{c}{\sin C} \\ \Rightarrow \frac{1+\sqrt{3}}{\sin A} &= \frac{2}{\sin B} = \frac{\sqrt{6}}{\sin 60^\circ} \\ \therefore \sin B &= \frac{2 \sin 60^\circ}{\sqrt{6}} = \frac{2 \times \frac{\sqrt{3}}{2}}{\sqrt{6}} = \frac{1}{\sqrt{2}} \\ \Rightarrow B &= 45^\circ \\ \therefore A &= 180^\circ - (60^\circ + 45^\circ) = 75^\circ \end{aligned}$$

Topic 2 Applications of Area, Napier's Analogy and Solution of a Triangle

1. For a $\triangle ABC$, it is given that $a = \sqrt{3} + 1$,

$$b = \sqrt{3} - 1 \text{ and } \angle A + \angle B = 120^\circ$$

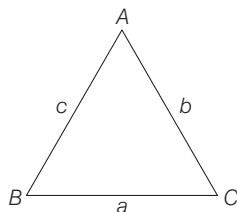

Clearly, $\angle C = 60^\circ$ [$\because \angle A + \angle B + \angle C = 180^\circ$]

Now, by tangent law, we have

$$\begin{aligned} \tan \frac{A-B}{2} &= \frac{a-b}{a+b} \cot \frac{C}{2} \\ &= \frac{(\sqrt{3}+1) - (\sqrt{3}-1)}{(\sqrt{3}+1) + (\sqrt{3}-1)} \cot \left(\frac{60^\circ}{2} \right) \\ &= \frac{2}{2\sqrt{3}} \cot (30^\circ) \\ &= \frac{1}{\sqrt{3}} \times \sqrt{3} = 1 \end{aligned}$$

$$\Rightarrow \tan \left(\frac{A-B}{2} \right) = 1 = \tan 45^\circ$$

$$\Rightarrow \frac{A-B}{2} = 45^\circ$$

$$\Rightarrow \angle A - \angle B = 90^\circ$$

On solving $\angle A - \angle B = 90^\circ$ and $\angle A + \angle B = 120^\circ$, we get

$$\angle A = 105^\circ \text{ and } \angle B = 15^\circ$$

So, $\angle A : \angle B = 7 : 1$

2. **PLAN** If $\triangle ABC$ has sides a, b, c .

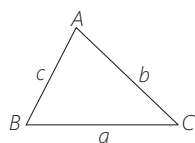

$$\text{Then, } \tan (A/2) = \frac{\sqrt{(s-b)(s-c)}}{s(s-a)}$$

$$\text{where, } s = \frac{a+b+c}{2} \Rightarrow s = \frac{2 + \frac{7}{2} + \frac{5}{2}}{2} = 4$$

$$\begin{aligned} \therefore \frac{2 \sin P - \sin 2P}{2 \sin P + \sin 2P} &= \frac{2 \sin P (1 - \cos P)}{2 \sin P (1 + \cos P)} \\ &= \frac{2 \sin^2 (P/2)}{2 \cos^2 (P/2)} = \tan^2 (P/2) \end{aligned}$$

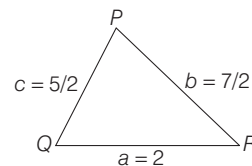

$$\begin{aligned} \Rightarrow \frac{(s-b)(s-c)}{s(s-a)} \times \frac{(s-b)(s-c)}{(s-b)(s-c)} \\ = \frac{[(s-b)(s-c)]^2}{\Delta^2} = \frac{\left(4 - \frac{7}{2}\right)^2 \left(4 - \frac{5}{2}\right)^2}{\Delta^2} = \left(\frac{3}{4\Delta}\right)^2 \end{aligned}$$

3. Let $AB = AC = a$ and $\angle A = 120^\circ$.

$$\therefore \text{Area of triangle} = \frac{1}{2} a^2 \sin 120^\circ$$

$$\begin{aligned} \text{where, } a = AD + BD &= \sqrt{3} \tan 30^\circ + \sqrt{3} \cot 15^\circ \\ &= 1 + \frac{\sqrt{3}}{\tan (45^\circ - 15^\circ)} \end{aligned}$$

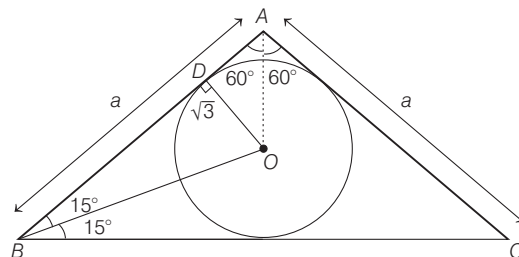

$$\begin{aligned} \Rightarrow a &= 1 + \sqrt{3} \left(\frac{1 + \tan 45^\circ \tan 30^\circ}{\tan 45^\circ - \tan 30^\circ} \right) \\ &= 1 + \sqrt{3} \left(\frac{\sqrt{3} + 1}{\sqrt{3} - 1} \right) = 4 + 2\sqrt{3} \end{aligned}$$

\therefore Area of a triangle

$$= \frac{1}{2} (4 + 2\sqrt{3})^2 \left(\frac{\sqrt{3}}{2} \right) = (12 + 7\sqrt{3}) \text{ sq units}$$

4. Let $a : b : c = 1 : \sqrt{3} : 2 \Rightarrow c^2 = a^2 + b^2$

\therefore Triangle is right angled at C.

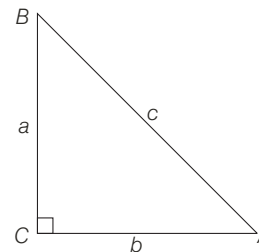

or

$$\angle C = 90^\circ$$

and

$$\frac{a}{b} = \frac{1}{\sqrt{3}}$$

538 Properties of Triangles

$$\text{In } \triangle BAC, \quad \tan A = \frac{a}{b} = \frac{1}{\sqrt{3}}$$

$$\Rightarrow A = 30^\circ$$

$$\text{and } B = 60^\circ \quad [\because A + B = 90^\circ]$$

$$\therefore \text{Ratio of angles, } A : B : C = 30^\circ : 60^\circ : 90^\circ = 1 : 2 : 3$$

5. For a $\triangle XYZ$, it is given that

$$\tan \frac{X}{2} + \tan \frac{Z}{2} = \frac{2y}{x+y+z}$$

$$\Rightarrow \frac{\Delta}{s(s-x)} + \frac{\Delta}{s(s-z)} = \frac{y}{s}$$

$$\Rightarrow \Delta \frac{(s-z+s-x)}{(s-x)(s-z)} = y$$

$$\Rightarrow \Delta = (s-x)(s-z)$$

$$\Rightarrow s(s-x)(s-y)(s-z) = (s-x)^2 (s-z)^2$$

$$\Rightarrow s^2 - sy = s^2 - (x+z)s + xz$$

$$\Rightarrow s(x+z-y) = xz$$

$$\Rightarrow (x+z)^2 - y^2 = 2xz$$

$$\Rightarrow x^2 + z^2 = y^2$$

$$\therefore y = \frac{\pi}{2}$$

$$\therefore X + Y + Z = \pi$$

$$\Rightarrow X + Z = \frac{\pi}{2} = Y$$

$$\Rightarrow X + Z = Y$$

$$\therefore \tan \frac{X}{2} = \frac{\sqrt{\frac{1-\cos x}{1+\cos x}}}{\sqrt{\frac{1+\frac{z}{y}}{1+\frac{z}{y}}}} = \sqrt{\frac{1-\frac{z}{y}}{1+\frac{z}{y}}}$$

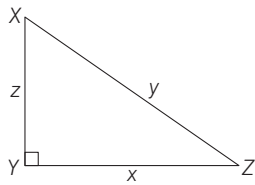

$$= \frac{\sqrt{y-z}}{\sqrt{y+z}} = \frac{\sqrt{y^2-z^2}}{y+z}$$

$$\tan \frac{X}{2} = \frac{x}{y+z} \quad \{\because x^2 + z^2 = y^2\}$$

6. By sine rule, $\frac{a}{\sin A} = \frac{b}{\sin B} = \frac{c}{\sin C}$

$$\Rightarrow \frac{\sqrt{3}+1}{\sin(105^\circ)} = \frac{b}{\sin 30^\circ}$$

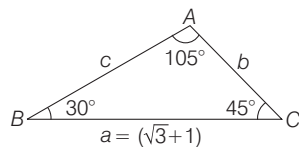

$$\Rightarrow b = \frac{(\sqrt{3}+1) \sin 30^\circ}{\sin 105^\circ}$$

\therefore Area of triangle

$$= \frac{1}{2} ab \sin 45^\circ = \frac{1}{2} (\sqrt{3}+1) \frac{(\sqrt{3}+1) \sin 30^\circ \sin 45^\circ}{\sin 105^\circ}$$

$$= \frac{1}{2} \cdot \frac{(\sqrt{3}+1)^2}{(\sin 45^\circ \cos 60^\circ + \cos 45^\circ \sin 60^\circ)} \cdot \frac{1}{2} \cdot \frac{1}{\sqrt{2}}$$

$$= \frac{1}{4\sqrt{2}} \cdot \frac{(3+1+2\sqrt{3})}{\left(\frac{1}{\sqrt{2}} \cdot \frac{1}{2} + \frac{1}{\sqrt{2}} \cdot \frac{\sqrt{3}}{2}\right)} = \frac{(4+2\sqrt{3})}{4\sqrt{2}(1+\sqrt{3})} \cdot 2\sqrt{2}$$

$$= \frac{(1+\sqrt{3})^2}{2(1+\sqrt{3})} = \frac{1+\sqrt{3}}{2} \text{ sq cm}$$

7. Since, $a^2+2a, 2a+3$ and a^2+3a+8 form sides of a triangle.

$$\text{Now, } a^2+3a+8 < (a^2+2a) + (2a+3)$$

$$\Rightarrow a^2+3a+8 < a^2+4a+3$$

$$\Rightarrow a > 5$$

...(i)

$$\text{Also, } (a^2+3a+8) + (2a+3) > a^2+2a$$

$$\Rightarrow 3a > -11$$

$$\Rightarrow a > -\frac{11}{3}$$

...(ii)

$$\text{Again, } (a^2+3a+8) + (a^2+2a) > 2a+3$$

$$\Rightarrow 2a^2+3a+5 > 0$$

which is always true.

\therefore Triangle is formed, if $a > 5$

8. Given, $\Delta \leq \frac{1}{4} \sqrt{(a+b+c)abc}$

$$\Rightarrow \frac{1}{4\Delta} \sqrt{(a+b+c)abc} \geq 1$$

$$\Rightarrow \frac{(a+b+c)abc}{16\Delta^2} \geq 1$$

$$\Rightarrow \frac{2sabc}{16\Delta^2} \geq 1$$

$$\Rightarrow \frac{sabc}{8 \cdot s(s-a)(s-b)(s-c)} \geq 1$$

$$\Rightarrow \frac{abc}{8(s-a)(s-b)(s-c)} \geq 1$$

$$\Rightarrow \frac{abc}{8} \geq (s-a)(s-b)(s-c)$$

Now, put $s-a = x \geq 0, s-b = y \geq 0, s-c = z \geq 0$

$$s-a+s-b = x+y$$

$$2s-a-b = x+y$$

$$c = x+y$$

Similarly, $a = y+z, b = x+z$

$$\Rightarrow \frac{(x+y)}{2} \cdot \frac{(y+z)}{2} \cdot \frac{(x+z)}{2} \geq xyz$$

which is true.

Now, equality will hold, if $x = y = z$

$$\Rightarrow a = b = c$$

\Rightarrow Triangle is equilateral.

9. If the triangle is equilateral, then

$$A = B = C = 60^\circ$$

$$\Rightarrow \tan A + \tan B + \tan C = 3 \tan 60^\circ = 3\sqrt{3}$$

Conversely assume that,

$$\tan A + \tan B + \tan C = 3\sqrt{3}$$

But in $\triangle ABC$, $A + B = 180^\circ - C$

Taking tan on both sides, we get

$$\tan(A + B) = \tan(180^\circ - C)$$

$$\Rightarrow \frac{\tan A + \tan B}{1 - \tan A \tan B} = -\tan C$$

$$\Rightarrow \tan A + \tan B = -\tan C + \tan A \tan B \tan C$$

$$\Rightarrow \tan A + \tan B + \tan C = \tan A \tan B \tan C = 3\sqrt{3}$$

\Rightarrow None of the tan A, tan B, tan C can be negative

So, $\triangle ABC$ cannot be obtuse angle triangle.

Also, $AM \geq GM$

$$\Rightarrow \frac{1}{3}[\tan A + \tan B + \tan C] \geq [\tan A \tan B \tan C]^{1/3}$$

$$\Rightarrow \frac{1}{3}(3\sqrt{3}) \geq (3\sqrt{3})^{1/3} \Rightarrow \sqrt{3} \geq \sqrt{3}.$$

So, equality can hold if and only if

$$\tan A = \tan B = \tan C$$

or $A = B = C$ or when the triangle is equilateral.

10. By using triangular inequality,

$$c < a + b$$

$$\Rightarrow c^2 < ca + ab$$

Similarly, $a^2 < ab + ac$ and $b^2 < bc + ab$

$$\therefore a^2 + b^2 + c^2 < 2ab + 2bc + 2ca$$

$$\Rightarrow (a^2 + b^2 + c^2) + 2ab + 2bc + 2ca < 4(ab + bc + ca)$$

$$\Rightarrow (a + b + c)^2 < 4(ab + bc + ca) \quad \dots (i)$$

Now, using AM-GM inequality in a, b and c , we get

$$\frac{a^2 + b^2}{2} \geq ab, \frac{b^2 + c^2}{2} \geq bc \text{ and } \frac{c^2 + a^2}{2} \geq ca$$

$$\Rightarrow a^2 + b^2 + c^2 \geq ab + bc + ca$$

$$\Rightarrow a^2 + b^2 + c^2 + 2ab + 2bc + 2ca \geq 3(ab + bc + ca)$$

$$\Rightarrow (a + b + c)^2 \geq 3(ab + bc + ca) \quad \dots (ii)$$

From Eqs. (i) and (ii), we get

$$3(ab + bc + ca) \leq (a + b + c)^2 < 4(ab + bc + ca)$$

11. Since, $A + B + C = \pi$

$$\Rightarrow B + C = \pi - \pi/4 = 3\pi/4 \quad \dots (i)$$

[$\because A = \pi/4$, given]

$$\therefore 0 < B, C < 3\pi/4$$

Also, given $\tan B \cdot \tan C = p$

$$\Rightarrow \frac{\sin B \cdot \sin C}{\cos B \cdot \cos C} = \frac{p}{1}$$

$$\Rightarrow \frac{\sin B \cdot \sin C + \cos B \cos C}{\sin B \cdot \sin C - \cos B \cdot \cos C} = \frac{p + 1}{p - 1}$$

$$\Rightarrow \frac{\cos(B - C)}{\cos(B + C)} = \frac{1 + p}{1 - p}$$

$$\Rightarrow \cos(B - C) = -\frac{(1 + p)}{\sqrt{2}(1 - p)} \quad \dots (ii)$$

[$\because B + C = 3\pi/4$]

Since, B or C can vary from 0 to $3\pi/4$

$$\therefore 0 \leq B - C < 3\pi/4$$

$$\Rightarrow -\frac{1}{\sqrt{2}} < \cos(B - C) \leq 1 \quad \dots (iii)$$

From Eqs. (ii) and (iii), $-\frac{1}{\sqrt{2}} < \frac{1 + p}{\sqrt{2}(p - 1)} \leq 1$

$$\Rightarrow -\frac{1}{\sqrt{2}} < \frac{1 + p}{\sqrt{2}(p - 1)} \text{ and } \frac{1 + p}{\sqrt{2}(p - 1)} \leq 1$$

$$\Rightarrow \frac{1 + p}{p - 1} + 1 \geq 0 \text{ and } \frac{1 + p - \sqrt{2}p + \sqrt{2}}{\sqrt{2}(p - 1)} \leq 0$$

$$\Rightarrow \frac{2p}{p - 1} \geq 0 \text{ and } \frac{(1 - \sqrt{2})\left(p - \frac{1 + \sqrt{2}}{1 - \sqrt{2}}\right)}{\sqrt{2}(p - 1)} \leq 0$$

$$\Rightarrow \frac{2p}{p - 1} > 0 \text{ and } \frac{(p - (\sqrt{2} + 1)^2)}{(p - 1)} \geq 0$$

$$\begin{array}{cccc} + & - & + & + & - & + \\ \hline & 0 & 1 & & 1 & (\sqrt{2} + 1)^2 \end{array}$$

$$\Rightarrow (p < 0 \text{ or } p > 1)$$

$$\text{and } (p < 1 \text{ or } p > (\sqrt{2} + 1)^2)$$

On combining above expressions, we get

$$p < 0 \text{ or } p \geq (\sqrt{2} + 1)^2$$

$$\text{i.e. } p \in (-\infty, 0) \cup [(\sqrt{2} + 1)^2, \infty)$$

$$\text{or } p \in (-\infty, 0) \cup [3 + 2\sqrt{2}, \infty)$$

12. It is given that a, b, c and area of triangle are rational.

$$\text{We have, } \tan \frac{B}{2} = \sqrt{\frac{(s - c)(s - a)}{s(s - b)}}$$

$$= \frac{\sqrt{s(s - a)(s - b)(s - c)}}{s(s - b)}$$

Again, a, b, c are rational given, $s = \frac{a + b + c}{2}$ are

rational, Also, $(s - b)$ is rational, since triangle is rational, therefore we get

$$\tan\left(\frac{B}{2}\right) = \frac{\Delta}{s(s - b)} \text{ is rational.}$$

Similarly, $\tan \frac{C}{2} = \frac{\Delta}{s(s - c)}$ is rational.

Therefore $a, \tan \frac{B}{2}, \tan \frac{C}{2}$ are rational.

which shows that, (i) \Rightarrow (ii).

Again, it is given that,

$$a, \tan \frac{B}{2}, \tan \frac{C}{2} \text{ are rational, then}$$

540 Properties of Triangles

$$\begin{aligned}\tan \frac{A}{2} &= \tan \left(\frac{\pi}{2} - \frac{B+C}{2} \right) \\ &= \cot \left(\frac{B+C}{2} \right) = \frac{1}{\tan \left(\frac{B}{2} + \frac{C}{2} \right)} \\ &= \frac{1 - \tan \left(\frac{B}{2} \right) \cdot \tan \left(\frac{C}{2} \right)}{\tan \left(\frac{B}{2} \right) + \tan \left(\frac{C}{2} \right)}\end{aligned}$$

Since, $\tan(B/2)$ and $\tan(C/2)$ are rational, hence $\tan(A/2)$ is a rational.

Now, $\sin A = \frac{2 \tan A/2}{1 + \tan^2 A/2}$ as $\tan(A/2)$ is a rational number, $\sin A$ is a rational. Similarly, $\sin B$ and $\sin C$ are. Thus, $a, \sin A, \sin B, \sin C$ are rational, therefore (ii) \Rightarrow (iii).

Again, $a, \sin A, \sin B, \sin C$ are rational.

By the sine rule,

$$\begin{aligned}\frac{a}{\sin A} &= \frac{b}{\sin B} = \frac{c}{\sin C} \\ \Rightarrow b &= \frac{a \sin B}{\sin A} \text{ and } c = \frac{a \sin C}{\sin A}\end{aligned}$$

Since $a, \sin A, \sin B$ and $\sin C$ are rational,

Hence, b and c are also rational.

$$\text{Also, } \Delta = \frac{1}{2} bc \sin A$$

As b, c and $\sin A$ are rational, so triangle is rational number. Therefore, a, b, c and triangle are rational.

Therefore, (iii) \Rightarrow (i).

13. Let ABC be a triangle with base $BC = a$ and altitude $AD = p$, then

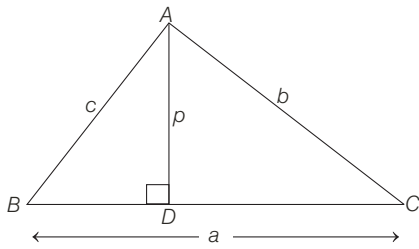

$$\text{Area of } \Delta ABC = \frac{1}{2} bc \sin A$$

$$\text{Also, area of } \Delta ABC = \frac{1}{2} ap$$

$$\therefore \frac{1}{2} ap = \frac{1}{2} bc \sin A$$

$$\Rightarrow p = \frac{bc \sin A}{a}$$

$$\Rightarrow p = \frac{abc \sin A}{a^2}$$

$$\Rightarrow p = \frac{abc \sin A \cdot (\sin^2 B - \sin^2 C)}{a^2(\sin^2 B - \sin^2 C)}$$

$$\begin{aligned}&= \frac{abc \sin A \cdot \sin(B+C) \sin(B-C)}{(b^2 \sin^2 A - c^2 \sin^2 A)} \\ &\left[\text{using sine rule, } \frac{a}{\sin A} = \frac{b}{\sin B} = \frac{c}{\sin C} \right] \\ &= \frac{abc \sin^2 A \cdot \sin(B-C)}{(b^2 - c^2) \cdot \sin^2 A} = \frac{abc \sin(B-C)}{b^2 - c^2} \\ &= \frac{ab^2 r \sin(B-C)}{b^2 - b^2 r^2} = \frac{ar \sin(B-C)}{1 - r^2}\end{aligned}$$

$$\Rightarrow p \leq \frac{ar}{1 - r^2} \quad [\because \sin(B-C) \leq 1]$$

14. Given, $\cos A \cos B + \sin A \sin B \sin C = 1$

$$\Rightarrow \sin C = \frac{1 - \cos A \cos B}{\sin A \sin B} \quad \dots(i)$$

$$\Rightarrow \frac{1 - \cos A \cos B}{\sin A \sin B} \leq 1 \quad [\because \sin C \leq 1]$$

$$\Rightarrow 1 - \cos A \cos B \leq \sin A \sin B$$

$$\Rightarrow 1 \leq \cos(A - B)$$

$$\Rightarrow \cos(A - B) \geq 1$$

$$\Rightarrow \cos(A - B) = 1 \quad [\because \text{as } \cos(\theta) \leq 1]$$

$$\Rightarrow A - B = 0$$

On putting $A = B$ in Eq. (i), we get

$$\sin C = \frac{1 - \cos^2 A}{\sin^2 A}$$

$$\Rightarrow \sin C = 1$$

$$\Rightarrow C = \pi/2$$

$$\text{Now, } A + B + C = \pi$$

$$\Rightarrow A + B = \frac{\pi}{2} \Rightarrow A = \frac{\pi}{4} \quad \left[\because A = B \text{ and } C = \frac{\pi}{2} \right]$$

$$\therefore \sin A : \sin B : \sin C = \sin \frac{\pi}{4} : \sin \frac{\pi}{4} : \sin \frac{\pi}{2}$$

$$\Rightarrow a : b : c = \frac{1}{\sqrt{2}} : \frac{1}{\sqrt{2}} : 1$$

$$= 1 : 1 : \sqrt{2}$$

15. Let a, b, c are the sides of a ΔABC .

$$\text{Given, } \cos A + \cos B + \cos C = \frac{3}{2}$$

$$\Rightarrow \frac{b^2 + c^2 - a^2}{2bc} + \frac{a^2 + c^2 - b^2}{2ac} + \frac{a^2 + b^2 - c^2}{2ab} = \frac{3}{2}$$

$$\Rightarrow ab^2 + ac^2 - a^3 + ba^2 + bc^2 - b^3 + ca^2 + cb^2 - c^3 = 3abc$$

$$\begin{aligned}\Rightarrow a(b-c)^2 + b(c-a)^2 + c(a-b)^2 \\ = \frac{(a+b+c)}{2} [(a-b)^2 + (b-c)^2 + (c-a)^2]\end{aligned}$$

$$\Rightarrow (a+b-c)(a-b)^2 + (b+c-a)(b-c)^2 + (c+a-b)(c-a)^2 = 0$$

[as we know, $a+b-c > 0, b+c-a > 0, c+a-b > 0$]

∴ Each term on the left of equation has positive coefficient multiplied by perfect square, each term must be separately zero.

$$\Rightarrow a = b = c$$

∴ Triangle is an equilateral.

16. Since, $\Delta = \frac{1}{2} ap_1 \Rightarrow \frac{1}{p_1} = \frac{a}{2\Delta}$

Similarly, $\frac{1}{p_2} = \frac{b}{2\Delta}, \frac{1}{p_3} = \frac{c}{2\Delta}$

$$\begin{aligned} \therefore \frac{1}{p_1} + \frac{1}{p_2} - \frac{1}{p_3} &= \frac{1}{2\Delta} (a + b - c) \\ &= \frac{2(s-c)}{2\Delta} = \frac{s-c}{\Delta} = \frac{s(s-c)}{ab} \cdot \frac{ab}{s\Delta} \\ &= \frac{ab}{\left(\frac{a+b+c}{2}\right)\Delta} \cdot \cos^2 \frac{C}{2} \\ &= \frac{2ab}{(a+b+c)\Delta} \cos^2 \frac{C}{2} \end{aligned}$$

17. We know that, $\Delta = \frac{1}{2} ap_1$

$$\Rightarrow p_1 = \frac{2\Delta}{a}$$

Similarly, $p_2 = \frac{2\Delta}{b}$ and $p_3 = \frac{2\Delta}{c}$

Now, $p_1 p_2 p_3 = \frac{8\Delta^3}{abc}$

Since, $\Delta = \frac{abc}{4R}$

$$\therefore p_1 p_2 p_3 = \frac{8}{abc} \cdot \frac{(abc)^3}{64R^3} = \frac{(abc)^2}{8R^3}$$

18. In ΔABC , by sine rule, $\frac{a}{\sin A} = \frac{2\sqrt{2}}{\sin 30^\circ} = \frac{4}{\sin C}$

$$\Rightarrow C = 45^\circ, C' = 135^\circ$$

When, $C = 45^\circ \Rightarrow A = 180^\circ - (45^\circ + 30^\circ) = 105^\circ$

When, $C' = 135^\circ \Rightarrow A = 180^\circ - (135^\circ + 30^\circ) = 15^\circ$

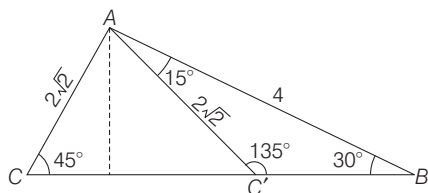

$$\begin{aligned} \text{Area of } \Delta ABC &= \frac{1}{2} AB \times AC \sin A \\ &= \frac{1}{2} \times 4 \times 2\sqrt{2} \sin (105^\circ) \\ &= 4\sqrt{2} \times \frac{\sqrt{3}+1}{2\sqrt{2}} \\ &= 2(\sqrt{3}+1) \text{ sq. units} \end{aligned}$$

$$\begin{aligned} \text{Area of } \Delta ABC' &= \frac{1}{2} AB \times AC \sin A \\ &= \frac{1}{2} \times 4 \times 2\sqrt{2} \sin (15^\circ) \\ &= 2(\sqrt{3}-1) \text{ sq. units} \end{aligned}$$

Difference of areas of triangle

$$= |2(\sqrt{3}+1) - 2(\sqrt{3}-1)| = 4 \text{ sq units}$$

Alternate Solution

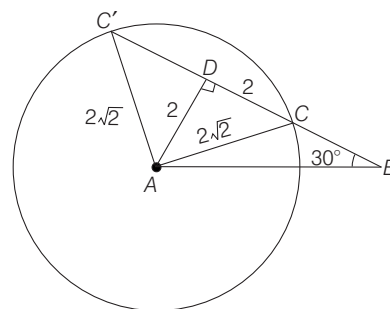

Here, $AD = 2, DC = 2$

Difference of areas of ΔABC and $\Delta ABC'$

$$\begin{aligned} &= \text{Area of } \Delta ACC' \\ &= \frac{1}{2} AD \times CC' = \frac{1}{2} \times 2 \times 4 = 4 \text{ sq units} \end{aligned}$$

Topic 3 Circumcircle, Incircle, Escribed, Orthocentre and Centroid of a Triangle

1. Let ABC be a given triangle with vertices $B(0, 2), C(4, 3)$ and let third vertex be $A(a, b)$

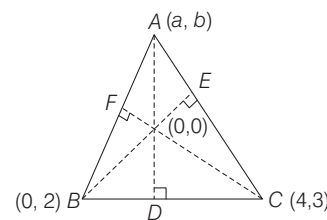

Also, let D, E and F are the foot of perpendiculars drawn from A, B and C respectively.

$$\text{Then, } AD \perp BC \Rightarrow \frac{b-0}{a-0} \times \frac{3-2}{4-0} = -1$$

[if two lines having slopes m_1 and m_2 , are perpendicular then $m_1 m_2 = -1$]

$$\Rightarrow b + 4a = 0 \quad \dots(i)$$

and

$$CF \perp AB$$

$$\Rightarrow \frac{b-2}{a-0} \times \frac{3-0}{4-0} = -1$$

$$\Rightarrow 3b - 6 = -4a$$

$$\Rightarrow 4a + 3b = 6 \quad \dots(ii)$$

From Eqs. (i) and (ii), we get

$$-b + 3b = 6 \Rightarrow 2b = 6$$

542 Properties of Triangles

$$\Rightarrow \quad b = 3$$

and $a = -\frac{3}{4}$ [from Eq. (i)]

So, the third vertex

$$(a, b) \equiv \left(-\frac{3}{4}, 3\right), \text{ which lies in II quadrant.}$$

2.

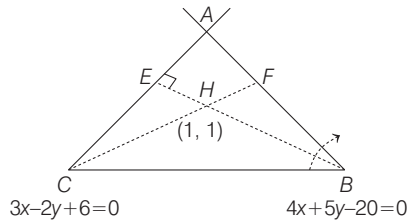

Let equation of AB be $4x + 5y - 20 = 0$ and AC be $3x - 2y + 6 = 0$

$$\text{Clearly, slope of } AC = \frac{3}{2}$$

$$[\because \text{slope of } ax + by + c = 0 \text{ is } -\frac{a}{b}]$$

\therefore Slope of altitude BH , which is perpendicular to

$$AC = -\frac{2}{3} \quad \left(\because m_{BH} = -\frac{1}{m_{AC}}\right)$$

Equation of BH is given by $y - y_1 = m(x - x_1)$

$$\text{Here, } m = -\frac{2}{3}, x_1 = 1 \text{ and } y_1 = 1$$

$$\therefore y - 1 = -\frac{2}{3}(x - 1)$$

$$\Rightarrow 2x + 3y - 5 = 0$$

Now, equation of AB is $4x + 5y - 20 = 0$ and

equation of BH is $2x + 3y - 5 = 0$

Solving these, we get point of intersection (i.e. coordinates of B).

$$\left. \begin{array}{l} 4x + 5y - 20 = 0 \\ 4x + 6y - 10 = 0 \end{array} \right\} \Rightarrow y = -10$$

On substituting $y = -10$ in $2x + 3y - 5 = 0$, we get $x = \frac{35}{2}$

$$\therefore B\left(\frac{35}{2}, -10\right)$$

Solving $4x + 5y - 20 = 0$ and $3x - 2y + 6 = 0$, we get coordinate of A .

$$\left. \begin{array}{l} 12x + 15y - 60 = 0 \\ 12x - 8y + 24 = 0 \end{array} \right\} \Rightarrow 23y = 84$$

$$\Rightarrow y = \frac{84}{23} \Rightarrow x = \frac{10}{23} \Rightarrow A\left(\frac{10}{23}, \frac{84}{23}\right)$$

$$\text{Now, slope of } AH = \left(\frac{y_2 - y_1}{x_2 - x_1}\right) = \left(\frac{\frac{84}{23} - 1}{\frac{10}{23} - 1}\right) = \frac{61}{-13}$$

$\therefore BC$ is perpendicular to AH .

$$\therefore \text{ Slope of } BC \text{ is } \frac{13}{61} \quad \left(\because m_{BC} = -\frac{1}{m_{AH}}\right)$$

Now, equation of line BC is given by $y - y_1 = m(x - x_1)$, where (x_1, y_1) are coordinates of B .

$$\therefore y - (-10) = \frac{13}{61}\left(x - \frac{35}{2}\right)$$

$$\Rightarrow y + 10 = \frac{13}{61 \times 2}(2x - 35)$$

$$\Rightarrow 122y + 1220 = 26x - 455$$

$$\Rightarrow 26x - 122y - 1675 = 0$$

$$3. \text{ PLAN (i) } \cos C = \frac{a^2 + b^2 - c^2}{2ab} \quad \text{(ii) } R = \frac{abc}{4\Delta}, r = \frac{\Delta}{s}$$

where, R, r, Δ denote the circumradius, inradius and area of triangle, respectively.

Let the sides of triangle be a, b and c .

$$\text{Given, } x = a + b$$

$$y = ab$$

$$x^2 - c^2 = y$$

$$\Rightarrow (a + b)^2 - c^2 = y$$

$$\Rightarrow a^2 + b^2 + 2ab - c^2 = ab$$

$$\Rightarrow a^2 + b^2 - c^2 = -ab$$

$$\Rightarrow \frac{a^2 + b^2 - c^2}{2ab} = -\frac{1}{2} = \cos 120^\circ$$

$$\Rightarrow \angle C = \frac{2\pi}{3}$$

$$\therefore R = \frac{abc}{4\Delta}, r = \frac{\Delta}{s} \Rightarrow \frac{r}{R} = \frac{4\Delta^2}{s(abc)}$$

$$= \frac{4\left[\frac{1}{2}ab \sin\left(\frac{2\pi}{3}\right)\right]^2}{\frac{x+c}{2} \cdot y \cdot c}$$

$$\therefore \frac{r}{R} = \frac{3y}{2c(x+c)}$$

4. First solve each option separately.

(a) If $a, \sin A, \sin B$ are given, then we can determine $b = \frac{a}{\sin A} \sin B, c = \frac{a}{\sin A} \sin C$. So, all the three sides are unique.

So, option (a) is incorrect.

(b) The three sides can uniquely make an acute angled triangle. So, option (b) is incorrect.

(c) If $a, \sin B, R$ are given, then we can determine $b = 2R \sin B, \sin A = \frac{a \sin B}{b}$. So, $\sin C$ can be determined.

Hence, side c can also be uniquely determined.

(d) If $a, \sin A, R$ are given, then

$$\frac{b}{\sin B} = \frac{c}{\sin C} = 2R$$

But this could not determine the exact values of b and c .

5. Here, $R^2 = MC^2 = \frac{1}{4}(a^2 + b^2)$ [by distance from origin]
 $= \frac{1}{4}c^2$ [by Pythagoras theorem]

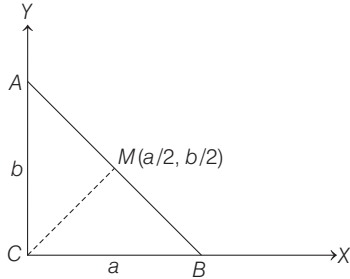

$\Rightarrow R = \frac{c}{2}$

Next, $r = (s - c) \tan (C/2) = (s - c) \tan \pi/4 = s - c$

$\therefore 2(r + R) = 2r + 2R = 2s - 2c + c$
 $= a + b + c - c$
 $= a + b$

6. Radius of incircle is, $r = \frac{\Delta}{s}$

Since, $\Delta = 16\sqrt{2}$
 Now, $s = \frac{6\sqrt{2} + 6\sqrt{2} + 4\sqrt{2}}{2} = 8\sqrt{2}$
 $\therefore r = \frac{16\sqrt{2}}{8\sqrt{2}} = 2$

7. Equation of circumcircle of ΔPRS is

$(x + 1)(x - 9) + y^2 + \lambda y = 0$
 It will pass through $(1, 2\sqrt{2})$, then
 $-16 + 8 + \lambda \cdot 2\sqrt{2} = 0$
 $\Rightarrow \lambda = \frac{8}{2\sqrt{2}} = 2\sqrt{2}$

\therefore Equation of circumcircle is
 $x^2 + y^2 - 8x + 2\sqrt{2}y - 9 = 0$

Hence, its radius is $3\sqrt{3}$.

Alternate Solution

Let $\angle PSR = \theta \Rightarrow \sin \theta = \frac{2\sqrt{2}}{2\sqrt{3}}$
 $\therefore \sin \theta = \frac{PR}{2R}$
 $\Rightarrow PR = 6\sqrt{2} = 2R \cdot \sin \theta$
 $\Rightarrow R = 3\sqrt{3}$

8. Coordinates of P and Q are $(1, 2\sqrt{2})$ and $(1, -2\sqrt{2})$.

Now, $PQ = \sqrt{(4\sqrt{2})^2 + 0^2} = 4\sqrt{2}$
 Area of $\Delta PQR = \frac{1}{2} \cdot 4\sqrt{2} \cdot 8 = 16\sqrt{2}$ sq units

Area of $\Delta PQS = \frac{1}{2} \cdot 4\sqrt{2} \cdot 2 = 4\sqrt{2}$ sq units

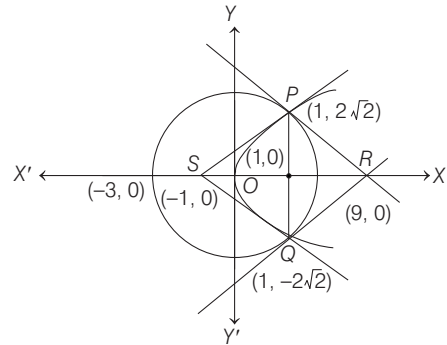

Ratio of areas of ΔPQS and ΔPQR is 1 : 4.

9. Let a non-right angled ΔPQR .

Now, by sine rule

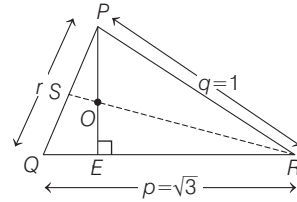

$\frac{P}{\sin P} = \frac{q}{\sin Q} = \frac{r}{\sin R} = 2 \times \text{circumradius}$
 $\Rightarrow \frac{\sqrt{3}}{\sin P} = \frac{1}{\sin Q} = \frac{r}{\sin R} = 2 \times 1$ [circumradius = 1 unit]
 $\Rightarrow \sin P = \frac{\sqrt{3}}{2}$ and $\sin Q = \frac{1}{2}$

$\Rightarrow P = 120^\circ$ and $Q = 30^\circ$ ($\because \Delta PQR$ is non-right angled triangle)

So, $R = 30^\circ$

$\Rightarrow r = 1$, so ΔPQR is an isosceles triangle. And, since RS and PE are the median of ΔPQR , so 'O' is centroid of the ΔPQR .

Now,

Option (a),

From Apollonius theorem,

$2(PE^2 + QE^2) = PQ^2 + PR^2$
 $\Rightarrow 2\left(PE^2 + \frac{3}{4}\right) = 1 + 1$
 $\Rightarrow PE^2 = 1 - \frac{3}{4} \Rightarrow PE^2 = \frac{1}{4} \Rightarrow PE = \frac{1}{2}$ units

and $OE = \frac{1}{3} PE = \frac{1}{6}$ units [$\because O$ divides PE is 2 : 1]

Option (b),

Again from Apollonius theorem,

$2(PS^2 + RS^2) = PR^2 + QR^2$
 $\Rightarrow 2\left(\frac{1}{4} + RS^2\right) = 1 + 3$
 $\Rightarrow RS^2 = 2 - \frac{1}{4} \Rightarrow RS^2 = \frac{7}{4} \Rightarrow RS = \frac{\sqrt{7}}{2}$ units

544 Properties of Triangles

Option (c),

$$\begin{aligned} \text{Area of } \triangle SOE &= \frac{1}{2} (OE) (ST) \\ &= \frac{1}{2} \times \frac{1}{6} [(PS) \sin 60^\circ] \\ &= \frac{1}{12} \times \frac{1}{2} \times \frac{\sqrt{3}}{2} \\ &= \frac{\sqrt{3}}{48} \text{ square units} \end{aligned}$$

Option (d),

$$\begin{aligned} \therefore \text{Inradius of } \triangle PQR &= \frac{\Delta}{s} = \frac{\frac{1}{2} pq \sin R}{\frac{1}{2} (p+q+r)} = \frac{\frac{1}{2} (\sqrt{3})(1) \frac{1}{2}}{\frac{1}{2} (\sqrt{3}+1+1)} \\ &= \frac{\sqrt{3}}{2} (2-\sqrt{3}) \text{ units} \end{aligned}$$

Hence, options (a), (b) and (d) are correct.

10. We have,
In $\triangle PQR$

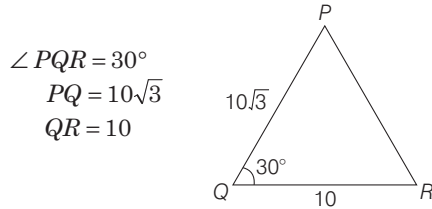

By cosine rule

$$\begin{aligned} \cos 30^\circ &= \frac{PQ^2 + QR^2 - PR^2}{2PQ \cdot QR} \\ \Rightarrow \frac{\sqrt{3}}{2} &= \frac{300 + 100 - PR^2}{200\sqrt{3}} \end{aligned}$$

$$\begin{aligned} \Rightarrow 300 &= 300 + 100 - PR^2 \\ \Rightarrow PR &= 10 \end{aligned}$$

Since, $PR = QR = 10$

$\therefore \angle QPR = 30^\circ$ and $\angle QRP = 120^\circ$

$$\begin{aligned} \text{Area of } \triangle PQR &= \frac{1}{2} PQ \cdot QR \cdot \sin 30^\circ \\ &= \frac{1}{2} \times 10\sqrt{3} \times 10 \times \frac{1}{2} = 25\sqrt{3} \end{aligned}$$

Radius of incircle of

$$\begin{aligned} \Delta PQR &= \frac{\text{Area of } \triangle PQR}{\text{Semi-perimetre of } \triangle PQR} \\ \text{i.e. } r &= \frac{\Delta}{s} = \frac{25\sqrt{3}}{10\sqrt{3} + 10 + 10} = \frac{25\sqrt{3}}{5(\sqrt{3} + 2)} \end{aligned}$$

$$\begin{aligned} \Rightarrow r &= 5\sqrt{3} (2-\sqrt{3}) \\ &= 10\sqrt{3} - 15 \end{aligned}$$

$$\begin{aligned} \text{and radius of circumcircle } (R) &= \frac{abc}{4\Delta} \\ &= \frac{10\sqrt{3} \times 10 \times 10}{4 \times 25\sqrt{3}} = 10 \end{aligned}$$

\therefore Area of circumcircle of

$$\Delta PQR = \pi R^2 = 100\pi$$

Hence, option (b), (c) and (d) are correct answer.

11. Given a $\triangle XYZ$, where $2s = x + y + z$

and
$$\frac{s-x}{4} = \frac{s-y}{3} = \frac{s-z}{2}$$

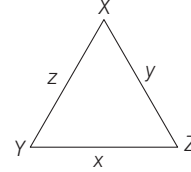

$$\begin{aligned} \therefore \frac{s-x}{4} &= \frac{s-y}{3} = \frac{s-z}{2} \\ &= \frac{3s - (x+y+z)}{4+3+2} = \frac{s}{9} \end{aligned}$$

or
$$\frac{s-x}{4} = \frac{s-y}{3} = \frac{s-z}{2} = \frac{s}{9} = \lambda \text{ (let)}$$

$$\Rightarrow s = 9\lambda, s = 4\lambda + x, s = 3\lambda + y$$

and
$$s = 2\lambda + z$$

$$\therefore s = 9\lambda, x = 5\lambda, y = 6\lambda, z = 7\lambda$$

Now,
$$\Delta = \sqrt{s(s-x)(s-y)(s-z)}$$

$$= \sqrt{9\lambda \cdot 4\lambda \cdot 3\lambda \cdot 2\lambda} = 6\sqrt{6}\lambda^2 \quad \text{[Heron's formula]} \quad \dots(i)$$

Also,
$$\pi r^2 = \frac{8\pi}{3}$$

$$\Rightarrow r^2 = \frac{8}{3} \quad \dots(ii)$$

and
$$R = \frac{xyz}{4\Delta} = \frac{(5\lambda)(6\lambda)(7\lambda)}{4 \cdot 6\sqrt{6}\lambda^2} = \frac{35\lambda}{4\sqrt{6}} \quad \dots(iii)$$

Now,
$$r^2 = \frac{8}{3} = \frac{\Delta^2}{S^2} = \frac{216\lambda^4}{81\lambda^2}$$

$$\Rightarrow \frac{8}{3} = \frac{8}{3} \lambda^2 \quad \text{[from Eq. (ii)]}$$

$$\Rightarrow \lambda = 1$$

(a) $\Delta XYZ = 6\sqrt{6}\lambda^2 = 6\sqrt{6}$

\therefore Option (a) is correct.

(b) Radius of circumcircle $(R) = \frac{35}{4\sqrt{6}} \lambda = \frac{35}{4\sqrt{6}}$

\therefore Option (b) is incorrect.

(c) Since,
$$r = 4R \sin \frac{X}{2} \cdot \sin \frac{Y}{2} \cdot \sin \frac{Z}{2}$$

$$\Rightarrow \frac{2\sqrt{2}}{\sqrt{3}} = 4 \cdot \frac{35}{4\sqrt{6}} \sin \frac{X}{2} \cdot \sin \frac{Y}{2} \cdot \sin \frac{Z}{2}$$

$$\Rightarrow \frac{4}{35} = \sin \frac{X}{2} \cdot \sin \frac{Y}{2} \cdot \sin \frac{Z}{2}$$

\therefore Option (c) is correct.

(d)
$$\sin^2 \left(\frac{X+Y}{2} \right) = \cos^2 \left(\frac{Z}{2} \right)$$

$$\text{as } \frac{X+Y}{2} = 90^\circ - \frac{Z}{2} = \frac{s(s-z)}{xy} = \frac{9 \times 2}{5 \times 6} = \frac{3}{5}$$

\therefore Option (d) is correct.

12. Let a straight line through the vertex P of a given ΔPQR intersects the side QR at the point S and the circumcircle of ΔPQR at the point T .

Points P, Q, R, T are concyclic, then $PS \cdot ST = QS \cdot SR$

Now, $\frac{PS + ST}{2} > \sqrt{PS \cdot ST}$ [\because AM > GM]

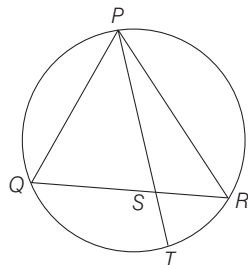

and $\frac{1}{PS} + \frac{1}{ST} > \frac{2}{\sqrt{PS \cdot ST}} = \frac{2}{\sqrt{QS \cdot SR}}$

Also, $\frac{SQ + QR}{2} > \sqrt{SQ \cdot SR}$

$\Rightarrow \frac{QR}{2} > \sqrt{SQ \cdot SR}$

$\Rightarrow \frac{1}{\sqrt{SQ \cdot SR}} > \frac{2}{QR}$

$\Rightarrow \frac{2}{\sqrt{SQ \cdot SR}} > \frac{4}{QR}$

$\therefore \frac{1}{PS} + \frac{1}{ST} > \frac{2}{\sqrt{QS \cdot SR}} > \frac{4}{QR}$

13. We have, $R = \frac{abc}{4\Delta}$ and $r = \frac{\Delta}{s}$

$$\frac{R}{r} = \frac{abc}{4\Delta} \cdot \frac{s}{\Delta} = \frac{abc \cdot s}{4\Delta^2} = \frac{abc}{4(s-a)(s-b)(s-c)}$$

But $a : b : c = 4 : 5 : 6$

$\Rightarrow \frac{a}{4} = \frac{b}{5} = \frac{c}{6} = k$ [given]

$\Rightarrow a = 4k, b = 5k, c = 6k$ [let]

Now, $s = \frac{1}{2}(a + b + c)$

$= \frac{1}{2}(4k + 5k + 6k) = \frac{15k}{2}$

$\therefore \frac{R}{r} = \frac{(4k)(5k)(6k)}{4\left(\frac{15k}{2} - 4k\right)\left(\frac{15k}{2} - 5k\right)\left(\frac{15k}{2} - 6k\right)}$

$= \frac{30k^3}{k^3\left(\frac{15-8}{2}\right)\left(\frac{15-10}{2}\right)\left(\frac{15-12}{2}\right)}$

$= \frac{30 \cdot 8}{7 \cdot 5 \cdot 3} = \frac{16}{7}$

14. Since, sides of a triangle subtends α, β, γ at the centre.

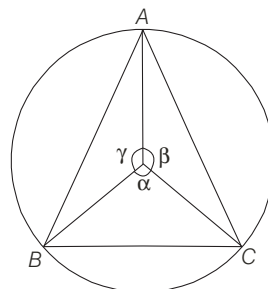

$\therefore \alpha + \beta + \gamma = 2\pi$... (i)

Now, arithmetic mean

$$= \frac{\cos\left(\frac{\pi}{2} + \alpha\right) + \cos\left(\frac{\pi}{2} + \beta\right) + \cos\left(\frac{\pi}{2} + \gamma\right)}{3}$$

As we know that, AM \geq GM, i.e.

AM is minimum, when $\frac{\pi}{2} + \alpha = \frac{\pi}{2} + \beta = \frac{\pi}{2} + \gamma$

or $\alpha = \beta = \gamma = 120^\circ$

\therefore Minimum value of arithmetic mean

$= \cos\left(\frac{\pi}{2} + \alpha\right)$

$= \cos(210^\circ) = -\frac{\sqrt{3}}{2}$

15. Here, central angle = $\frac{360^\circ}{9} = 40^\circ$

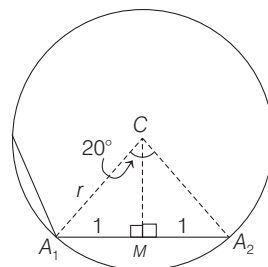

In ΔACM , $\frac{1}{r} = \sin 20^\circ$

$\Rightarrow r = \operatorname{cosec} 20^\circ$

\therefore Radius of circle = $\operatorname{cosec} 20^\circ$

16. Since, the circles with radii 3, 4 and 5 touch each other externally and P is the point of intersection of tangents.

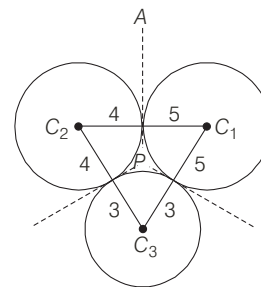

546 Properties of Triangles

$\Rightarrow P$ is incentre of $\Delta C_1C_2C_3$.

Thus, distance of point P from the points of contact

= inradius (r) of $\Delta C_1C_2C_3$

$$\text{i.e. } r = \frac{\Delta}{s} = \sqrt{\frac{s(s-a)(s-b)(s-c)}{s}}$$

where, $2s = 7 + 8 + 9 \Rightarrow s = 12$

$$\text{Hence, } r = \sqrt{\frac{(12-7)(12-8)(12-9)}{12}} = \sqrt{\frac{5 \cdot 4 \cdot 3}{12}} = \sqrt{5}$$

17. We know that, $I_n = \frac{n}{2} r^2 \sin \frac{2\pi}{n}$

[since, I_n is area of regular polygon]

$$\Rightarrow \frac{2I_n}{n} = \sin \frac{2\pi}{n} \quad [\because r = 1] \dots (i)$$

and $O_n = nr^2 \tan \frac{\pi}{2}$

[since, O_n is area of circumscribing polygon]

$$\frac{O_n}{n} = \tan \frac{\pi}{n} \quad \dots (ii)$$

On dividing Eq. (i) by Eq. (ii), we get

$$\frac{2I_n}{O_n} = \frac{\sin \frac{2\pi}{n}}{\tan \frac{\pi}{n}}$$

$$\Rightarrow \frac{I_n}{O_n} = \cos^2 \frac{\pi}{n} = \frac{1 + \cos \frac{2\pi}{n}}{2}$$

$$\therefore \frac{I_n}{O_n} = \frac{1 + \sqrt{1 - (2I_n/O_n)^2}}{2} \quad [\text{from Eq. (i)}]$$

$$\Rightarrow I_n = \frac{O_n}{2} (1 + \sqrt{1 - (2I_n/O_n)^2})$$

18. The quadrilateral $HEKJ$ is a square, because all four angles are right angles and $JK = JH$.

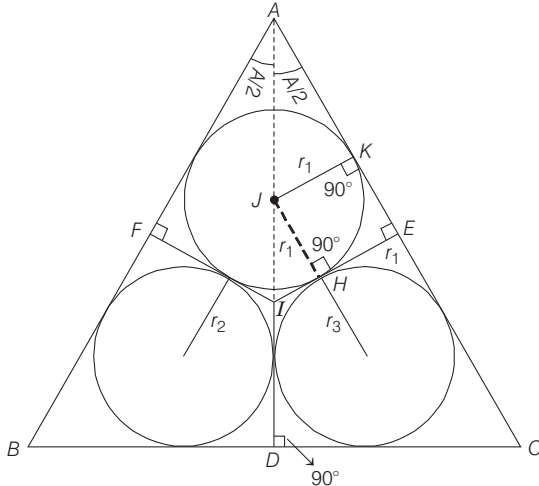

Therefore, $HE = JK = r_1$ and $IE = r$ [given]

$$\Rightarrow IH = r - r_1$$

Now, in right angled ΔIHJ ,

$$\angle JIH = \pi/2 - A/2$$

$$[\because \angle IEA = 90^\circ, \angle IAE = A/2 \text{ and } \angle JIH = \angle AIE]$$

In ΔJIH ,

$$\tan \left(\frac{\pi}{2} - \frac{A}{2} \right) = \frac{r_1}{r - r_1} \Rightarrow \cot \frac{A}{2} = \frac{r_1}{r - r_1}$$

$$\text{Similarly, } \cot \frac{B}{2} = \frac{r_2}{r - r_2} \text{ and } \cot \frac{C}{2} = \frac{r_3}{r - r_3}$$

On adding above results, we get

$$\begin{aligned} \cot A/2 + \cot B/2 + \cot C/2 &= \cot A/2 \cot B/2 \cot C/2 \\ \Rightarrow \frac{r_1}{r - r_1} + \frac{r_2}{r - r_2} + \frac{r_3}{r - r_3} &= \frac{r_1 r_2 r_3}{(r - r_1)(r - r_2)(r - r_3)} \end{aligned}$$

19. It is clear from the figure that, $OA = R$

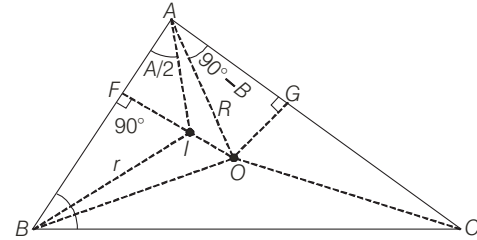

$$AI = \frac{IF}{\sin(A/2)}$$

$$\because \Delta AIF \text{ is right angled triangle, so } = \frac{r}{\sin(A/2)}$$

$$\text{But } r = 4R \sin(A/2) \sin(B/2) \sin(C/2)$$

$$\therefore AI = 4R \sin(B/2) \sin(C/2)$$

$$\text{Again, } \angle GOA = B \Rightarrow \angle OAG = 90^\circ - B$$

Therefore, $\angle IAO = \angle IAC - \angle OAC$

$$= A/2 - (90^\circ - B) = \frac{1}{2}(A + 2B - 180^\circ)$$

$$= \frac{1}{2}(A + 2B - A - B - C) = \frac{1}{2}(B - C)$$

$$\text{In } \Delta OAI, OI^2 = OA^2 + AI^2 - 2(OA)(AI) \cos(\angle IAO)$$

$$= R^2 + [4R \sin(B/2) \sin(C/2)]^2$$

$$- 2R \cdot [4R \sin(B/2) \sin(C/2)] \cos\left(\frac{B-C}{2}\right)$$

$$= [R^2 + 16R^2 \sin^2(B/2) \sin^2(C/2)$$

$$- 8R^2 \sin(B/2) \sin(C/2) \cos\left(\frac{B-C}{2}\right)]$$

$$= R^2 [1 + 16 \sin^2(B/2) \sin^2(C/2)$$

$$- 8 \sin(B/2) \sin(C/2) \cos\left(\frac{B-C}{2}\right)]$$

$$= R^2 [1 + 8 \sin(B/2) \sin(C/2)$$

$$\left\{ 2 \sin(B/2) \sin(C/2) - \cos\left(\frac{B-C}{2}\right) \right\}]$$

$$\begin{aligned}
 &= R^2[1 + 8 \sin(B/2) \sin(C/2) \\
 &\quad \left\{ \cos\left(\frac{B-C}{2}\right) + \cos\left(\frac{B+C}{2}\right) - \cos\left(\frac{B-C}{2}\right) \right\}] \\
 &= R^2 \left[1 - 8 \sin(B/2) \sin(C/2) \cos\left(\frac{B+C}{2}\right) \right] \\
 &= R^2 \left[1 - 8 \sin(B/2) \sin(C/2) \cos\left(\frac{\pi}{2} - \frac{A}{2}\right) \right] \\
 &\quad \left[\because \frac{A}{2} + \frac{B}{2} + \frac{C}{2} = \frac{\pi}{2} \right] \\
 &= R^2[1 - 8 \sin(A/2) \sin(B/2) \sin(C/2)] \\
 &= R^2 \left[1 - 8 \left(\frac{r}{4R}\right) \right] = R^2 - 2Rr
 \end{aligned}$$

Now, in right angled ΔBIO ,

$$\begin{aligned}
 &OB^2 = BI^2 + IO^2 \\
 \Rightarrow &R^2 = BI^2 + R^2 - 2Rr \\
 \Rightarrow &2Rr = BI^2 \\
 \Rightarrow &2Rr = r^2 / \sin^2(B/2) \\
 \Rightarrow &2R = r / \sin^2(B/2) \\
 \Rightarrow &2R \sin^2 B/2 = r \\
 \Rightarrow &R(1 - \cos B) = r \\
 \Rightarrow &\frac{abc}{4\Delta}(1 - \cos B) = \frac{\Delta}{s} \\
 \Rightarrow &abc(1 - \cos B) = \frac{4\Delta^2}{s} \\
 \Rightarrow &abc \left[1 - \frac{a^2 + c^2 - b^2}{2ac} \right] = \frac{4\Delta^2}{s} \\
 \Rightarrow &abc \left[\frac{2ac - a^2 - c^2 + b^2}{2ac} \right] = \frac{4\Delta^2}{s}
 \end{aligned}$$

$$\begin{aligned}
 \Rightarrow &b[b^2 - (a-c)^2] = \frac{4\Delta^2}{s} \\
 \Rightarrow &b[b^2 - (a-c)^2] = 8(s-a)(s-b)(s-c) \\
 \Rightarrow &b[\{b-(a-c)\}\{b+(a-c)\}] \\
 &\quad = 8(s-a)(s-b)(s-c) \\
 \Rightarrow &b[(b+c-a)(b+a-c)] = 8(s-a)(s-b)(s-c) \\
 \Rightarrow &b[(2s-2a)(2s-2c)] = 8(s-a)(s-b)(s-c) \\
 \Rightarrow &b[2 \cdot 2(s-a)(s-c)] = 8(s-a)(s-b)(s-c) \\
 \Rightarrow &b = 2s - 2b \\
 \Rightarrow &2b = a + c
 \end{aligned}$$

which shows that b is arithmetic mean between a and c .

20. Since, r_1, r_2 and r_3 are exradii of ΔABC are in HP.

$$\begin{aligned}
 \therefore &\frac{1}{r_1}, \frac{1}{r_2}, \frac{1}{r_3} \text{ are in AP.} \\
 \Rightarrow &\frac{s-a}{\Delta}, \frac{s-b}{\Delta}, \frac{s-c}{\Delta} \text{ are in AP.} \\
 \Rightarrow &s-a, s-b, s-c \text{ are in AP.} \\
 \Rightarrow &-a, -b, -c \text{ are in AP.} \\
 \Rightarrow &a, b, c \text{ are in AP.}
 \end{aligned}$$

21. $\sin C = \frac{\sqrt{3}}{2}$ and C is given to be obtuse.

$$\begin{aligned}
 \Rightarrow C &= \frac{2\pi}{3} = \sqrt{a^2 + b^2 - 2ab \cos C} \\
 &= \sqrt{6^2 + 10^2 - 2 \times 6 \times 10 \times \cos \frac{2\pi}{3}} = 14 \\
 \therefore r &= \frac{\Delta}{s} \Rightarrow r^2 = \frac{225 \times 3}{\left(\frac{6+10+14}{2}\right)^2} = 3
 \end{aligned}$$

24

Vectors

Topic 1 Scalar Product of Two Vectors

Objective Questions I (Only one correct option)

1. Let $A(3, 0, -1)$, $B(2, 10, 6)$ and $C(1, 2, 1)$ be the vertices of a triangle and M be the mid-point of AC . If G divides BM in the ratio $2:1$, then $\cos(\angle GOA)$ (O being the origin) is equal to (2019 Main, 10 April I)

- (a) $\frac{1}{\sqrt{15}}$ (b) $\frac{1}{2\sqrt{15}}$ (c) $\frac{1}{\sqrt{30}}$ (d) $\frac{1}{6\sqrt{10}}$

2. If a unit vector \mathbf{a} makes angles $\frac{\pi}{3}$ with $\hat{\mathbf{i}}$, $\frac{\pi}{4}$ with $\hat{\mathbf{j}}$ and $\theta \in (0, \pi)$ with $\hat{\mathbf{k}}$, then a value of θ is (2019 Main, 9 April II)

- (a) $\frac{5\pi}{6}$ (b) $\frac{\pi}{4}$ (c) $\frac{5\pi}{12}$ (d) $\frac{2\pi}{3}$

3. Let $\mathbf{a} = \hat{\mathbf{i}} + \hat{\mathbf{j}} + \sqrt{2}\hat{\mathbf{k}}$, $\mathbf{b} = b_1\hat{\mathbf{i}} + b_2\hat{\mathbf{j}} + \sqrt{2}\hat{\mathbf{k}}$ and $\mathbf{c} = 5\hat{\mathbf{i}} + \hat{\mathbf{j}} + \sqrt{2}\hat{\mathbf{k}}$ be three vectors such that the projection vector of \mathbf{b} on \mathbf{a} is \mathbf{a} . If $\mathbf{a} + \mathbf{b}$ is perpendicular to \mathbf{c} , then $|\mathbf{b}|$ is equal to (2019 Main, 9 Jan II)

- (a) 6 (b) 4
(c) $\sqrt{22}$ (d) $\sqrt{32}$

4. If lines $x = ay + b$, $z = cy + d$ and $x = a'z + b'$, $y = c'z + d'$ are perpendicular, then (2019 Main, 9 Jan II)

- (a) $ab' + bc' + 1 = 0$ (b) $bb' + cc' + 1 = 0$
(c) $aa' + c + c' = 0$ (d) $cc' + a + a' = 0$

5. Let O be the origin and let PQR be an arbitrary triangle. The point S is such that

$$\begin{aligned} \overrightarrow{OP} \cdot \overrightarrow{OQ} + \overrightarrow{OR} \cdot \overrightarrow{OS} &= \overrightarrow{OR} \cdot \overrightarrow{OP} + \overrightarrow{OQ} \cdot \overrightarrow{OS} \\ &= \overrightarrow{OQ} \cdot \overrightarrow{OR} + \overrightarrow{OP} \cdot \overrightarrow{OS} \end{aligned}$$

Then the triangle PQR has S as its (2017 Adv.)

- (a) centroid (b) orthocentre
(c) incentre (d) circumcentre

6. Let $\vec{\mathbf{a}} = \hat{\mathbf{i}} + \hat{\mathbf{j}} + \hat{\mathbf{k}}$, $\vec{\mathbf{b}} = \hat{\mathbf{i}} - \hat{\mathbf{j}} + \hat{\mathbf{k}}$ and $\vec{\mathbf{c}} = \hat{\mathbf{i}} - \hat{\mathbf{j}} - \hat{\mathbf{k}}$ be three vectors. A vector $\vec{\mathbf{v}}$ in the plane of $\vec{\mathbf{a}}$ and $\vec{\mathbf{b}}$, whose projection on $\vec{\mathbf{c}}$ is $\frac{1}{\sqrt{3}}$, is given by (2011)

- (a) $\hat{\mathbf{i}} - 3\hat{\mathbf{j}} + 3\hat{\mathbf{k}}$ (b) $-3\hat{\mathbf{i}} - 3\hat{\mathbf{j}} - \hat{\mathbf{k}}$
(c) $3\hat{\mathbf{i}} - \hat{\mathbf{j}} + 3\hat{\mathbf{k}}$ (d) $\hat{\mathbf{i}} + 3\hat{\mathbf{j}} - 3\hat{\mathbf{k}}$

7. Two adjacent sides of a parallelogram $ABCD$ are given by $\vec{AB} = 2\hat{\mathbf{i}} + 10\hat{\mathbf{j}} + 11\hat{\mathbf{k}}$ and $\vec{AD} = -\hat{\mathbf{i}} + 2\hat{\mathbf{j}} + 2\hat{\mathbf{k}}$. The side AD is rotated by an acute angle α in the plane of the parallelogram so that AD becomes

AD' . If AD' makes a right angle with the side AB , then the cosine of the angle α is given by (2010)

- (a) $\frac{8}{9}$ (b) $\frac{\sqrt{17}}{9}$ (c) $\frac{1}{9}$ (d) $\frac{4\sqrt{5}}{9}$

8. Let P, Q, R and S be the points on the plane with position vectors $-2\hat{\mathbf{i}} - \hat{\mathbf{j}}, 4\hat{\mathbf{i}}, 3\hat{\mathbf{i}} + 3\hat{\mathbf{j}}$ and $-3\hat{\mathbf{i}} + 2\hat{\mathbf{j}}$, respectively. The quadrilateral $PQRS$ must be a (2010)

- (a) parallelogram, which is neither a rhombus nor a rectangle
(b) square
(c) rectangle, but not a square
(d) rhombus, but not a square

9. Let two non-collinear unit vectors $\hat{\mathbf{a}}$ and $\hat{\mathbf{b}}$ form an acute angle. A point P moves, so that at any time t the position vector \overrightarrow{OP} (where, O is the origin) is given by $\hat{\mathbf{a}} \cos t + \hat{\mathbf{b}} \sin t$. When P is farthest from origin O , let M be the length of \overrightarrow{OP} and $\hat{\mathbf{u}}$ be the unit vector along \overrightarrow{OP} . Then, (2008, 3M)

(a) $\hat{\mathbf{u}} = \frac{\hat{\mathbf{a}} + \hat{\mathbf{b}}}{|\hat{\mathbf{a}} + \hat{\mathbf{b}}|}$ and $M = (1 + \hat{\mathbf{a}} \cdot \hat{\mathbf{b}})^{1/2}$

(b) $\hat{\mathbf{u}} = \frac{\hat{\mathbf{a}} - \hat{\mathbf{b}}}{|\hat{\mathbf{a}} - \hat{\mathbf{b}}|}$ and $M = (1 + \hat{\mathbf{a}} \cdot \hat{\mathbf{b}})^{1/2}$

(c) $\hat{\mathbf{u}} = \frac{\hat{\mathbf{a}} + \hat{\mathbf{b}}}{|\hat{\mathbf{a}} + \hat{\mathbf{b}}|}$ and $M = (1 + 2\hat{\mathbf{a}} \cdot \hat{\mathbf{b}})^{1/2}$

(d) $\hat{\mathbf{u}} = \frac{\hat{\mathbf{a}} - \hat{\mathbf{b}}}{|\hat{\mathbf{a}} - \hat{\mathbf{b}}|}$ and $M = (1 + 2\hat{\mathbf{a}} \cdot \hat{\mathbf{b}})^{1/2}$

10. Let, $\vec{\mathbf{a}} = \hat{\mathbf{i}} + 2\hat{\mathbf{j}} + \hat{\mathbf{k}}$, $\vec{\mathbf{b}} = \hat{\mathbf{i}} - \hat{\mathbf{j}} + \hat{\mathbf{k}}$, $\vec{\mathbf{c}} = \hat{\mathbf{i}} + \hat{\mathbf{j}} - \hat{\mathbf{k}}$. A vector coplanar to $\vec{\mathbf{a}}$ and $\vec{\mathbf{b}}$ has a projection along $\vec{\mathbf{c}}$ of magnitude $\frac{1}{\sqrt{3}}$, then the vector is (2006, 3M)

- (a) $4\hat{\mathbf{i}} - \hat{\mathbf{j}} + 4\hat{\mathbf{k}}$ (b) $4\hat{\mathbf{i}} + \hat{\mathbf{j}} - 4\hat{\mathbf{k}}$
(c) $2\hat{\mathbf{i}} + \hat{\mathbf{j}} + \hat{\mathbf{k}}$ (d) None of these

11. If $\vec{a}, \vec{b}, \vec{c}$ are three non-zero, non-coplanar vectors

$$\text{and } \vec{b}_1 = \vec{b} - \frac{\vec{b} \cdot \vec{a}}{|\vec{a}|^2} \vec{a}, \vec{b}_2 = \vec{b} + \frac{\vec{b} \cdot \vec{a}}{|\vec{a}|^2} \vec{a},$$

$$\vec{c}_1 = \vec{c} - \frac{\vec{c} \cdot \vec{a}}{|\vec{a}|^2} \vec{a} - \frac{\vec{c} \cdot \vec{b}}{|\vec{b}|^2} \vec{b}, \vec{c}_2 = \vec{c} - \frac{\vec{c} \cdot \vec{a}}{|\vec{a}|^2} \vec{a} - \frac{\vec{c} \cdot \vec{b}_1}{|\vec{b}_1|^2} \vec{b}_1,$$

$$\vec{c}_3 = \vec{c} - \frac{\vec{c} \cdot \vec{a}}{|\vec{a}|^2} \vec{a} - \frac{\vec{c} \cdot \vec{b}_2}{|\vec{b}_2|^2} \vec{b}_2, \vec{c}_4 = \vec{a} - \frac{\vec{c} \cdot \vec{a}}{|\vec{a}|^2} \vec{a}.$$

Then, which of the following is a set of mutually orthogonal vectors? (2005, 1M)

- (a) $\{\vec{a}, \vec{b}_1, \vec{c}_1\}$ (b) $\{\vec{a}, \vec{b}_1, \vec{c}_2\}$
 (c) $\{\vec{a}, \vec{b}_2, \vec{a}_3\}$ (d) $\{\vec{a}, \vec{b}_2, \vec{c}_4\}$

12. If \vec{a} and \vec{b}_1 are two unit vectors such that $\vec{a} + 2\vec{b}$ and $5\vec{a} - 4\vec{b}$, are perpendicular to each other, then the angle between \vec{a} and \vec{b} is (2002, 1M)

- (a) 45° (b) 60°
 (c) $\cos^{-1}\left(\frac{1}{3}\right)$ (d) $\cos^{-1}\left(\frac{2}{7}\right)$

13. If \vec{a}, \vec{b} and \vec{c} are unit vectors, then $|\vec{a} - \vec{b}|^2 + |\vec{b} - \vec{c}|^2 + |\vec{c} - \vec{a}|^2$ does not exceed (2001, 2M)

- (a) 4 (b) 9
 (c) 8 (d) 6

14. Let \vec{u}, \vec{v} and \vec{w} be vectors such that $\vec{u} + \vec{v} + \vec{w} = \vec{0}$. If $|\vec{u}| = 3, |\vec{v}| = 4$ and $|\vec{w}| = 5$, then $\vec{u} \cdot \vec{v} + \vec{v} \cdot \vec{w} + \vec{w} \cdot \vec{u}$ is (1995, 2M)

- (a) 47 (b) -25
 (c) 0 (d) 25

15. The number of vectors of unit length perpendicular to vectors $\vec{a} = (1, 1, 0)$ and $\vec{b} = (0, 1, 1)$ is (1987, 2M)

- (a) one (b) two
 (c) three (d) infinite

16. A vector \vec{a} has components $2p$ and 1 with respect to a rectangular cartesian system. This system is rotated through a certain angle about the origin in the counter clockwise sense. If, with respect to the new system, \vec{a} has components $p + 1$ and 1 , then (1986, 2M)

- (a) $p = 0$ (b) $p = 1$ or $p = -\frac{1}{3}$
 (c) $p = -1$ or $p = \frac{1}{3}$ (d) $p = 1$ or $p = -1$

17. The points with position vectors $60\hat{i} + 3\hat{j}, 40\hat{i} - 8\hat{j}, a\hat{i} - 52\hat{j}$ are collinear, if (1983, 1M)

- (a) $a = -40$ (b) $a = 40$
 (c) $a = 20$ (d) None of these

Objective Question II

(One or more than one correct option)

18. Let $\vec{a} = 2\hat{i} - \hat{j} + \hat{k}, \vec{b} = \hat{i} + 2\hat{j} - \hat{k}$ and $\vec{c} = \hat{i} + \hat{j} - 2\hat{k}$ be three vectors. A vector in the plane of \vec{b} and \vec{c} , whose projection on \vec{a} is of magnitude $\sqrt{2/3}$, is (1993, 2M)
 (a) $2\hat{i} + 3\hat{j} - 3\hat{k}$ (b) $2\hat{i} + 3\hat{j} + 3\hat{k}$
 (c) $-2\hat{i} - \hat{j} + 5\hat{k}$ (d) $2\hat{i} + \hat{j} + 5\hat{k}$

Integer & Numerical Answer Type Question

19. Let \vec{a} and \vec{b} be two unit vectors such that $\vec{a} \cdot \vec{b} = 0$. For some $x, y \in R$, let $\vec{c} = x\vec{a} + y\vec{b} + (\vec{a} \times \vec{b})$. If $|\vec{c}| = 2$ and the vector \vec{c} is inclined at the same angle α to both \vec{a} and \vec{b} , then the value of $8 \cos^2 \alpha$ is (2018 Adv.)

Fill in the Blanks

20. The components of a vector \vec{a} along and perpendicular to a non-zero vector \vec{b} areand.....respectively. (1988, 2M)
21. A, B, C and D , are four points in a plane with position vectors $\vec{a}, \vec{b}, \vec{c}$ and \vec{d} respectively such that

$$(\vec{a} - \vec{d}) \cdot (\vec{b} - \vec{c}) = (\vec{b} - \vec{d}) \cdot (\vec{c} - \vec{a}) = 0$$

The point D , then, is the... of the ΔABC . (1984, 2M)

22. Let $\vec{A}, \vec{B}, \vec{C}$ be vectors of length 3, 4, 5 respectively. Let \vec{A} be perpendicular to $\vec{B} + \vec{C}$, \vec{B} to $\vec{C} + \vec{A}$ and \vec{C} to $\vec{A} + \vec{B}$. Then, the length of vector $\vec{A} + \vec{B} + \vec{C}$ is ... (1981, 2M)

True/False

23. The points with position vectors $\vec{a} + \vec{b}, \vec{a} - \vec{b}$ and $\vec{a} + k\vec{b}$ are collinear for all real values of k . (1984, 1M)

Analytical & Descriptive Questions

24. Find 3-dimensional vectors $\vec{v}_1, \vec{v}_2, \vec{v}_3$ satisfying
 $\vec{v}_1 \cdot \vec{v}_1 = 4, \vec{v}_1 \cdot \vec{v}_2 = -2, \vec{v}_1 \cdot \vec{v}_3 = 6,$
 $\vec{v}_2 \cdot \vec{v}_2 = 2, \vec{v}_2 \cdot \vec{v}_3 = -5, \vec{v}_3 \cdot \vec{v}_3 = 29$ (2001, 5M)
25. Show, by vector methods, that the angular bisectors of a triangle are concurrent and find an expression for the position vector of the point of concurrency in terms of the position vectors of the vertices. (2001, 5M)
26. In a ΔABC , D and E are points on BC and AC respectively, such that $BD = 2DC$ and $AE = 3EC$. Let P be the point of intersection of AD and BE . Find BP/PE using vector methods. (1993, 5M)

550 Vectors

27. Determine the value of c , so that for all real x , the vector $cx\hat{i} - 6\hat{j} - 3\hat{k}$ and $x\hat{i} + 2\hat{j} + 2cx\hat{k}$ make an obtuse angle with each other. (1991, 4M)
28. In a $\triangle OAB$, E is the mid-point of BO and D is a point on AB such that $AD : DB = 2 : 1$. If OD and AE intersect at P , determine the ratio $OP : PD$ using methods. (1989, 4M)
29. Let $OACB$ be a parallelogram with O at the origin and OC a diagonal. Let D be the mid-point of OA . Using vector methods prove that BD and CO intersect in the same ratio. Determine this ratio. (1988, 3M)
30. Let $\vec{A}(t) = f_1(t)\hat{i} + f_2(t)\hat{j}$ and $\vec{B}(t) = g(t)\hat{i} + g_2(t)\hat{j}$, $t \in [0, 1]$, f_1, f_2, g_1, g_2 are continuous functions. If $\vec{A}(t)$ and $\vec{B}(t)$ are non-zero vectors for all t and $\vec{A}(0) = 2\hat{i}$,

$\vec{A}(1) = 6\hat{i} + 2\hat{j}$, $\vec{B}(0) = 3\hat{i} + 2\hat{j}$ and $\vec{B}(1) = 2\hat{j} + 6\hat{j}$.
Then, show that $\vec{A}(t)$ and $\vec{B}(t)$ are parallel for some t .

Integer & Numerical Answer Type Questions

31. Suppose that \mathbf{p}, \mathbf{q} and \mathbf{r} are three non-coplanar vectors in R^3 . Let the components of a vector \mathbf{s} along \mathbf{p}, \mathbf{q} and \mathbf{r} be 4, 3 and 5, respectively. If the components of this vector \mathbf{s} along $(-\mathbf{p} + \mathbf{q} + \mathbf{r})$, $(\mathbf{p} - \mathbf{q} + \mathbf{r})$ and $(-\mathbf{p} - \mathbf{q} + \mathbf{r})$ are x, y and z respectively, then the value of $2x + y + z$ is (2015 Adv.)
32. If \vec{a}, \vec{b} and \vec{c} are unit vectors satisfying $|\vec{a} - \vec{b}|^2 + |\vec{b} - \vec{c}|^2 + |\vec{c} - \vec{a}|^2 = 9$, then $|2\vec{a} + 5\vec{b} + 5\vec{c}|$ is equal to (2012)

Topic 2 Vector Product of Two Vectors

Objective Questions I (Only one correct option)

1. Let $\mathbf{a} = \hat{i} - 2\hat{j} + \hat{k}$ and $\mathbf{b} = \hat{i} - \hat{j} + \hat{k}$ be two vectors. If \mathbf{c} is a vector such that $\mathbf{b} \times \mathbf{c} = \mathbf{b} \times \mathbf{a}$ and $\mathbf{c} \cdot \mathbf{a} = 0$, then $\mathbf{c} \cdot \mathbf{b}$ is equal to (2020 Main, 8 Jan II)
- (a) $\frac{1}{2}$ (b) $-\frac{3}{2}$
(c) $-\frac{1}{2}$ (d) -1
2. Let $\mathbf{a} = 3\hat{i} + 2\hat{j} + 2\hat{k}$ and $\mathbf{b} = \hat{i} + 2\hat{j} - 2\hat{k}$ be two vectors. If a vector perpendicular to both the vectors $\mathbf{a} + \mathbf{b}$ and $\mathbf{a} - \mathbf{b}$ has the magnitude 12, then one such vector is (2019 Main, 12 April II)
- (a) $\pm 4(2\hat{i} + 2\hat{j} + \hat{k})$ (b) $\pm 4(2\hat{i} - 2\hat{j} - \hat{k})$
(c) $\pm 4(2\hat{i} + 2\hat{j} - \hat{k})$ (d) $\pm 4(-2\hat{i} - 2\hat{j} + \hat{k})$
3. Let $\alpha \in R$ and the three vectors $\mathbf{a} = \alpha\hat{i} + \hat{j} + 3\hat{k}$, $\mathbf{b} = 2\hat{i} + \hat{j} - \alpha\hat{k}$ and $\mathbf{c} = \alpha\hat{i} - 2\hat{j} + 3\hat{k}$. Then, the set $S = \{\alpha : \mathbf{a}, \mathbf{b} \text{ and } \mathbf{c} \text{ are coplanar}\}$ (2019 Main, 12 April II)
- (a) is singleton
(b) is empty
(c) contains exactly two positive numbers
(d) contains exactly two numbers only one of which is positive
4. If the length of the perpendicular from the point $(\beta, 0, \beta)$ ($\beta \neq 0$) to the line, $\frac{x}{1} = \frac{y-1}{0} = \frac{z+1}{-1}$ is $\sqrt{\frac{3}{2}}$, then β is equal to (2019 Main, 10 April I)
- (a) 2 (b) -2
(c) -1 (d) 1

5. Let $\vec{\alpha} = 3\hat{i} + \hat{j}$ and $\vec{\beta} = 2\hat{i} - \hat{j} + 3\hat{k}$. If $\vec{\beta} = \vec{\beta}_1 - \vec{\beta}_2$, where $\vec{\beta}_1$ is parallel to $\vec{\alpha}$ and $\vec{\beta}_2$ is perpendicular to $\vec{\alpha}$, then $\vec{\beta}_1 \times \vec{\beta}_2$ is equal to (2019 Main, 9 April I)
- (a) $\frac{1}{2}(3\hat{i} - 9\hat{j} + 5\hat{k})$ (b) $\frac{1}{2}(-3\hat{i} + 9\hat{j} + 5\hat{k})$
(c) $-3\hat{i} + 9\hat{j} + 5\hat{k}$ (d) $3\hat{i} - 9\hat{j} - 5\hat{k}$
6. Let $\mathbf{a} = 3\hat{i} + 2\hat{j} + x\hat{k}$ and $\mathbf{b} = \hat{i} - \hat{j} + \hat{k}$, for some real x . Then $|\mathbf{a} \times \mathbf{b}| = r$ is possible if (2019 Main, 8 April II)
- (a) $0 < r \leq \sqrt{\frac{3}{2}}$ (b) $\sqrt{\frac{3}{2}} < r \leq 3\sqrt{\frac{3}{2}}$
(c) $3\sqrt{\frac{3}{2}} < r < 5\sqrt{\frac{3}{2}}$ (d) $r \geq 5\sqrt{\frac{3}{2}}$
7. A tetrahedron has vertices $P(1, 2, 1)$, $Q(2, 1, 3)$, $R(-1, 1, 2)$ and $O(0, 0, 0)$. The angle between the faces OPQ and PQR is (2019 Main, 12 Jan I)
- (a) $\cos^{-1}\left(\frac{7}{31}\right)$ (b) $\cos^{-1}\left(\frac{9}{35}\right)$ (c) $\cos^{-1}\left(\frac{19}{35}\right)$ (d) $\cos^{-1}\left(\frac{17}{31}\right)$
8. Let $\mathbf{a} = 2\hat{i} + \hat{j} - 2\hat{k}$, $\mathbf{b} = \hat{i} + \hat{j}$ and \mathbf{c} be a vector such that $|\mathbf{c} - \mathbf{a}| = 3$, $|(\mathbf{a} \times \mathbf{b}) \times \mathbf{c}| = 3$ and the angle between \mathbf{c} and $\mathbf{a} \times \mathbf{b}$ is 30° . Then, $\mathbf{a} \cdot \mathbf{c}$ is equal to (2017 Main)
- (a) $\frac{25}{8}$ (b) 2 (c) 5 (d) $\frac{1}{8}$
9. If \vec{a} and \vec{b} are vectors such that $|\vec{a} + \vec{b}| = \sqrt{29}$ and $\vec{a} \times (2\hat{i} + 3\hat{j} + 4\hat{k}) = (2\hat{i} + 3\hat{j} + 4\hat{k}) \times \vec{b}$, then a possible value of $(\vec{a} + \vec{b}) \cdot (-7\hat{i} + 2\hat{j} + 3\hat{k})$ is (2012)
- (a) 0 (b) 3
(c) ± 4 (d) 8

10. Let $\vec{a}, \vec{b}, \vec{c}$ be unit vectors such that $\vec{a} + \vec{b} + \vec{c} = \vec{0}$. Which one of the following is correct? (2007, 3M)
- (a) $\vec{a} \times \vec{b} = \vec{b} \times \vec{c} = \vec{c} \times \vec{a} = \vec{0}$
 (b) $\vec{a} \times \vec{b} = \vec{b} \times \vec{c} = \vec{c} \times \vec{a} \neq \vec{0}$
 (c) $\vec{b} \times \vec{b} = \vec{b} \times \vec{c} = \vec{a} \times \vec{c} = \vec{0}$
 (d) $\vec{a} \times \vec{b}, \vec{b} \times \vec{c}, \vec{c} \times \vec{a}$ are mutually perpendicular
11. If the vectors \vec{a}, \vec{b} and \vec{c} from the sides BC, CA and AB respectively of a ΔABC , then
- (a) $\vec{a} \cdot \vec{b} + \vec{b} \cdot \vec{c} + \vec{c} \cdot \vec{a} = 0$ (2000, 2M)
 (b) $\vec{a} \times \vec{b} = \vec{b} \times \vec{c} = \vec{c} \times \vec{a}$
 (c) $\vec{a} \cdot \vec{b} = \vec{b} \cdot \vec{c} = \vec{c} \cdot \vec{a}$
 (d) $\vec{a} \times \vec{b} + \vec{b} \times \vec{c} + \vec{c} \times \vec{a} = \vec{0}$

Objective Questions II

(One or more than one correct option)

12. Let a and b be positive real numbers. Suppose $\vec{PQ} = a\hat{i} + b\hat{j}$ and $\vec{PS} = a\hat{i} - b\hat{j}$ are adjacent sides of a parallelogram $PQRS$. Let \vec{u} and \vec{v} be the projection vectors of $\vec{w} = \hat{i} + \hat{j}$ along \vec{PQ} and \vec{PS} , respectively. If $|\vec{u}| + |\vec{v}| = |\vec{w}|$ and if the area of the parallelogram $PQRS$ is 8, then which of the following statements is/are TRUE? (2020 Adv.)
- (a) $a + b = 4$
 (b) $a - b = 2$
 (c) The length of the diagonal PR of the parallelogram $PQRS$ is 4
 (d) w is an angle bisector of the vectors PQ and PS
13. Let ΔPQR be a triangle. Let $\vec{a} = \vec{QR}, \vec{b} = \vec{RP}$ and $\vec{c} = \vec{PQ}$. If $|\vec{a}| = 12, |\vec{b}| = 4\sqrt{3}$ and $\vec{b} \cdot \vec{c} = 24$, then which of the following is/are true? (2015 Adv.)
- (a) $\frac{|\vec{c}|^2}{2} - |\vec{a}| = 12$ (b) $\frac{|\vec{c}|^2}{2} + |\vec{a}| = 30$
 (c) $|\vec{a} \times \vec{b} + \vec{c} \times \vec{a}| = 48\sqrt{3}$ (d) $\vec{a} \cdot \vec{b} = -72$
14. Let \vec{A} be vector parallel to line of intersection of planes P_1 and P_2 through origin. P_1 is parallel to the vectors $2\hat{j} + 3\hat{k}$ and $4\hat{j} - 3\hat{k}$ and P_2 is parallel to $3\hat{i} + 3\hat{j}$, then the angle between vector \vec{A} and $2\hat{i} + \hat{j} - 2\hat{k}$ is (2006, 5M)
- (a) $\frac{\pi}{2}$ (b) $\frac{\pi}{4}$
 (c) $\frac{\pi}{6}$ (d) $\frac{3\pi}{4}$
15. Let \vec{a} and \vec{b} be two non-collinear unit vectors. If $\vec{u} = \vec{a} - (\vec{a} \cdot \vec{b})\vec{b}$ and $\vec{v} = \vec{a} \times \vec{b}$, then $|\vec{v}|$ is (1999, 3M)
- (a) $|\vec{u}|$ (b) $|\vec{u}| + |\vec{u} \cdot \vec{a}|$
 (c) $|\vec{u}| + |\vec{u} \cdot \vec{b}|$ (d) $|\vec{u}| + \vec{u} \cdot (\vec{a} + \vec{b})$

Integer & Numerical Answer Type Question

16. In a triangle PQR , let $\vec{a} = \vec{QR}, \vec{b} = \vec{RP}$ and $\vec{c} = \vec{PQ}$. If $|\vec{a}| = 3, |\vec{b}| = 4$ and $\frac{\vec{a} \cdot (\vec{c} - \vec{b})}{\vec{c} \cdot (\vec{a} - \vec{b})} = \frac{|\vec{a}|}{|\vec{a}| + |\vec{b}|}$, then the value of $|\vec{a} \times \vec{b}|^2$ is (2020 Adv.)

Assertion and Reason

For the following question, choose the correct answer from the codes (a), (b), (c) and (d) defined as follows.

- (a) Statement I is true, Statement II is also true; Statement II is the correct explanation of Statement I
 (b) Statement I is true, Statement II is also true; Statement II is not the correct explanation of Statement I
 (c) Statement I is true; Statement II is false
 (d) Statement I is false; Statement II is true
17. Let the vectors $\vec{PQ}, \vec{QR}, \vec{RS}, \vec{ST}, \vec{TU}$ and \vec{UP} represent the sides of a regular hexagon.
- Statement I $\vec{PQ} \times (\vec{RS} + \vec{ST}) \neq \vec{0}$.
 because
 Statement II $\vec{PQ} \times \vec{RS} = \vec{0}$ and $\vec{PQ} \times \vec{ST} \neq \vec{0}$. (2007, 3M)

Passage Based Problems

Let O be the origin and $\vec{OX}, \vec{OY}, \vec{OZ}$ be three unit vectors in the directions of the sides $\vec{QR}, \vec{RP}, \vec{PQ}$ respectively, of a triangle PQR . (2017 Adv.)

18. If the triangle PQR varies, then the minimum value of $\cos(P + Q) + \cos(Q + R) + \cos(R + P)$ is
- (a) $-\frac{3}{2}$ (b) $\frac{3}{2}$ (c) $\frac{5}{3}$ (d) $-\frac{5}{3}$
19. $|\vec{OX} \times \vec{OY}| =$
- (a) $\sin(P + Q)$ (b) $\sin(P + R)$
 (c) $\sin(Q + R)$ (d) $\sin 2R$

Fill in the Blanks

20. If \vec{b} and \vec{c} are any two non-collinear unit vectors and \vec{a} is any vector, then
- $$(\vec{a} \cdot \vec{b})\vec{b} + (\vec{a} \cdot \vec{c})\vec{c} + \frac{\vec{a} \cdot (\vec{b} \times \vec{c})}{|\vec{b} \times \vec{c}|^2} (\vec{b} \times \vec{c}) = \dots \dots \dots$$
- (1996, 2M)
21. The unit vector perpendicular to the plane determined by $P(1, -1, 2), Q(2, 0, -1)$ and $R(0, 2, 1)$ is ... (1983, 2M)
22. The area of the triangle whose vertices are $A(1, -1, 2), B(2, 1, -1), C(3, -1, 2)$ is ... (1983, 2M)

True/False

23. Let \vec{A}, \vec{B} and \vec{C} be unit vectors. If $\vec{A} \cdot \vec{B} = \vec{A} \cdot \vec{C} = 0$ and that the angle between \vec{B} and \vec{C} is $\pi/6$. Then, $\vec{A} = \pm 2(\vec{B} \times \vec{C})$. (1981, 2M)

552 Vectors

Analytical & Descriptive Questions

24. If $\vec{a}, \vec{b}, \vec{c}, \vec{d}$ are four distinct vectors satisfying the conditions $\vec{a} \times \vec{b} = \vec{c} \times \vec{d}$ and $\vec{a} \times \vec{c} = \vec{b} \times \vec{d}$, then prove that $\vec{a} \cdot \vec{b} + \vec{c} \cdot \vec{d} \neq \vec{a} \cdot \vec{c} + \vec{b} \cdot \vec{d}$. (2004, 2M)

25. For any two vectors \vec{u} and \vec{v} , prove that

$$(i) |\vec{u} \cdot \vec{v}|^2 + |\vec{u} \times \vec{v}|^2 = |\vec{u}|^2 |\vec{v}|^2$$

$$(ii) (1 + |\vec{u}|^2)(1 + |\vec{v}|^2) = |1 - \vec{u} \cdot \vec{v}|^2 + |\vec{u} + \vec{v} + (\vec{u} \times \vec{v})|^2 \quad (1998, 8M)$$

26. If A, B, C, D are any four points in space, then prove that $|\vec{AB} \times \vec{CD} + \vec{BC} \times \vec{AD} + \vec{CA} \times \vec{BD}| = 4$ (area of ΔABC). (1987, 2M)

27. If A_1, A_2, \dots, A_n are the vertices of a regular plane polygon with n sides and O is its centre. Then, show that

$$\sum_{i=1}^{n-1} (\vec{OA}_i \times \vec{OA}_{i+1}) = (1-n) (\vec{OA}_2 \times \vec{OA}_1). \quad (1982, 2M)$$

Topic 3 Scalar Triple Product/Dot Product/Mixed Product

Objective Questions I (Only one correct option)

1. The sum of the distinct real values of μ , for which the vectors, $\mu\hat{i} + \hat{j} + \hat{k}$, $\hat{i} + \mu\hat{j} + \hat{k}$, $\hat{i} + \hat{j} + \mu\hat{k}$ are coplanar, is (2019 Main, 12 Jan I)

- (a) 2 (b) 0
(c) 1 (d) -1

2. Let $\mathbf{a} = \hat{i} + 2\hat{j} + 4\hat{k}$, $\mathbf{b} = \hat{i} + \lambda\hat{j} + 4\hat{k}$ and $\mathbf{c} = 2\hat{i} + 4\hat{j} + (\lambda^2 - 1)\hat{k}$ be coplanar vectors. Then, the non-zero vector $\mathbf{a} \times \mathbf{c}$ is (2019 Main, 11 Jan I)

- (a) $-10\hat{i} + 5\hat{j}$
(b) $-10\hat{i} - 5\hat{j}$
(c) $-14\hat{i} - 5\hat{j}$
(d) $-14\hat{i} + 5\hat{j}$

3. If $\vec{a}, \vec{b}, \vec{c}$ and \vec{d} are the unit vectors such that $(\vec{a} \times \vec{b}) \cdot (\vec{c} \times \vec{d}) = 1$ and $\vec{a} \cdot \vec{c} = \frac{1}{2}$, then (2009)

- (a) $\vec{a}, \vec{b}, \vec{c}$ are non-coplanar
(b) $\vec{a}, \vec{b}, \vec{d}$ are non-coplanar
(c) \vec{b}, \vec{d} are non-parallel
(d) \vec{a}, \vec{d} are parallel and \vec{b}, \vec{c} are parallel

4. The edges of a parallelepiped are of unit length and are parallel to non-coplanar unit vector $\hat{a}, \hat{b}, \hat{c}$ such that $\hat{a} \cdot \hat{b} = \hat{b} \cdot \hat{c} = \hat{c} \cdot \hat{a} = \frac{1}{2}$. Then, the volume of the parallelepiped is (2008, 3M)

- (a) $\frac{1}{\sqrt{2}}$ cu unit (b) $\frac{1}{2\sqrt{2}}$ cu unit
(c) $\frac{\sqrt{3}}{2}$ cu unit (d) $\frac{1}{\sqrt{3}}$ cu unit

5. The number of distinct real values of λ , for which the vectors $-\lambda^2\hat{i} + \hat{j} + \hat{k}$, $\hat{i} - \lambda^2\hat{j} + \hat{k}$ and $\hat{i} + \hat{j} - \lambda^2\hat{k}$ are coplanar, is (2007, 3M)

- (a) 0 (b) 1
(c) 2 (d) 3

6. The value of a , so that the volume of parallelepiped formed by $\hat{i} + a\hat{j} + \hat{k}$, $\hat{j} + a\hat{k}$ and $a\hat{i} + \hat{k}$ become minimum, is (2003, 1M)

- (a) -3 (b) 3 (c) $1/\sqrt{3}$ (d) $\sqrt{3}$

7. If $\vec{V} = 2\vec{i} + \vec{j} - \vec{k}$ and $\vec{W} = \vec{i} + 3\vec{k}$. If \vec{U} is a unit vector, then the maximum value of the scalar triple product $[\vec{U} \vec{V} \vec{W}]$ is (2002, 1M)

- (a) -1 (b) $\sqrt{10} + \sqrt{6}$
(c) $\sqrt{59}$ (d) $\sqrt{60}$

8. If $\vec{a} = \hat{i} - \hat{k}$, $\vec{b} = x\hat{i} + \hat{j} + (1-x)\hat{k}$ and $\vec{c} = y\hat{i} + x\hat{j} + (1+x-y)\hat{k}$. Then, $[\vec{a} \vec{b} \vec{c}]$ depends on (2001, 2M)

- (a) only x (b) only y
(c) neither x nor y (d) both x and y

9. If \vec{a}, \vec{b} and \vec{c} are unit coplanar vectors, then the scalar triple product $[2\vec{a} - \vec{b} \ 2\vec{b} - \vec{c} \ 2\vec{c} - \vec{a}]$ is (2000, 2M)

- (a) 0 (b) 1
(c) $-\sqrt{3}$ (d) $\sqrt{3}$

10. For three vectors $\vec{u}, \vec{v}, \vec{w}$ which of the following expressions is not equal to any of the remaining three?

- (a) $\vec{u} \cdot (\vec{v} \times \vec{w})$ (b) $(\vec{v} \times \vec{w}) \cdot \vec{u}$ (1998, 2M)
(c) $\vec{v} \cdot (\vec{u} \times \vec{w})$ (d) $(\vec{u} \times \vec{v}) \cdot \vec{w}$

11. If $\vec{a} = \hat{i} + \hat{j} + \hat{k}$, $\vec{b} = 4\hat{i} + 3\hat{j} + 4\hat{k}$ and $\vec{c} = \alpha\hat{i} + \beta\hat{j} + \hat{k}$ are linearly dependent vectors and $|\vec{c}| = \sqrt{3}$, then

- (a) $\alpha = 1, \beta = -1$ (b) $\alpha = 1, \beta = \pm 1$ (1998, 2M)
(c) $\alpha = -1, \beta = \pm 1$ (d) $\alpha = \pm 1, \beta = 1$

12. If \vec{a}, \vec{b} and \vec{c} are three non-coplanar vectors, then $(\vec{a} + \vec{b} + \vec{c}) \cdot [(\vec{a} + \vec{b}) \times (\vec{a} + \vec{c})]$ equals (1995, 2M)

- (a) 0 (b) $[\vec{c} \vec{b} \vec{c}]$
(c) $2 \cdot [\vec{c} \vec{b} \vec{c}]$ (d) $[\vec{a} \vec{b} \vec{c}]$

13. Let $\vec{a} = \hat{i} - \hat{j}$, $\vec{b} = \hat{j} - \hat{k}$, $\vec{c} = \hat{k} - \hat{i}$. If \vec{d} is a unit vector such that $\vec{a} \cdot \vec{d} = 0 = [\vec{b} \ \vec{c} \ \vec{d}]$, then \vec{d} equals (1995, 2M)

- (a) $\pm \frac{\hat{i} + \hat{j} - 2\hat{k}}{\sqrt{6}}$ (b) $\pm \frac{\hat{i} + \hat{j} - \hat{k}}{\sqrt{3}}$
 (c) $\pm \frac{\hat{i} + \hat{j} + \hat{k}}{\sqrt{3}}$ (d) $\pm \hat{k}$

14. Let a, b, c be distinct non-negative numbers. If the vectors $a\hat{i} + a\hat{j} + c\hat{k}$, $\hat{i} + \hat{k}$ and $c\hat{i} + c\hat{j} + b\hat{k}$ lie in a plane, then c is (1993, 1M)

- (a) the arithmetic mean of a and b
 (b) the geometric mean of a and b
 (c) the harmonic mean of a and b
 (d) equal to zero

15. Let $\vec{a} = a_1\hat{i} + a_2\hat{j} + a_3\hat{k}$, $\vec{b} = b_1\hat{i} + b_2\hat{j} + b_3\hat{k}$ and $\vec{c} = c_1\hat{i} + c_2\hat{j} + c_3\hat{k}$ be three non-zero vectors such that \vec{c} is a unit vector perpendicular to both the vectors \vec{a} and \vec{b} . If the angle between \vec{a} and \vec{b} is $\frac{\pi}{6}$,

then $\begin{vmatrix} a_1 & a_2 & a_3 \\ b_1 & b_2 & b_3 \\ c_1 & c_2 & c_3 \end{vmatrix}^2$ is equal to (1986, 2M)

- (a) 0
 (b) 1
 (c) $\frac{1}{4}(a_1^2 + a_2^2 + a_3^2)(b_1^2 + b_2^2 + b_3^2)$
 (d) $\frac{3}{4}(a_1^2 + a_2^2 + a_3^2)(b_1^2 + b_2^2 + b_3^2)(c_1^2 + c_2^2 + c_3^2)$

16. The volume of the parallelopiped whose sides are given by $\vec{OA} = 2\hat{i} - 3\hat{j}$, $\vec{OB} = \hat{i} + \hat{j} - \hat{k}$,

$\vec{OC} = 3\hat{i} - \hat{k}$, is (1983, 1M)

- (a) $\frac{4}{13}$ (b) 4
 (c) $\frac{2}{7}$ (d) None of these

17. For non-zero vectors $\vec{a}, \vec{b}, \vec{c}$, $(\vec{a} \times \vec{b}) \cdot \vec{c} = |\vec{a}| |\vec{b}| |\vec{c}|$ holds, if and only if (1982, 2M)

- (a) $\vec{a} \cdot \vec{b} = 0, \vec{b} \cdot \vec{c} = 0$ (b) $\vec{b} \cdot \vec{c} = 0, \vec{c} \cdot \vec{a} = 0$
 (c) $\vec{c} \cdot \vec{a} = 0, \vec{a} \cdot \vec{b} = 0$ (d) $\vec{a} \cdot \vec{b} = \vec{b} \cdot \vec{c} = \vec{c} \cdot \vec{a} = 0$

18. The scalar $\vec{A} \cdot [(\vec{B} + \vec{C}) \times (\vec{A} + \vec{B} + \vec{C})]$ equals (1981, 2M)

- (a) 0
 (b) $[\vec{A} \ \vec{B} \ \vec{C}] + [\vec{B} \ \vec{C} \ \vec{A}]$
 (c) $[\vec{A} \ \vec{B} \ \vec{C}]$
 (d) None of the above

Objective Questions II

(One or more than one correct option)

19. Let $\vec{u} = u_1\hat{i} + u_2\hat{j} + u_3\hat{k}$ be a unit vector in R^3 and $\vec{w} = \frac{1}{\sqrt{6}}(\hat{i} + \hat{j} + 2\hat{k})$. Given that there exists a vector \vec{v} in R^3 , such that $|\vec{u} + \vec{v}| = 1$ and $\vec{w} \cdot (\vec{u} + \vec{v}) = 1$. (2016 Adv.)

Which of the following statement(s) is/are correct?

- (a) There is exactly one choice for such \vec{v}
 (b) There are infinitely many choices for such \vec{v}
 (c) If \hat{u} lies in the XY -plane, then $|u_1| = |u_2|$
 (d) If \hat{u} lies in the XY -plane, then $2|u_1| = |u_3|$

20. Which of the following expressions are meaningful operations? (1998, 2M)

- (a) $\vec{u} \cdot (\vec{v} \times \vec{w})$
 (b) $(\vec{u} \cdot \vec{v}) \cdot \vec{w}$
 (c) $(\vec{u} \cdot \vec{v}) \vec{w}$
 (d) $\vec{u} \times (\vec{v} \cdot \vec{w})$

Fill in the Blanks

21. Let $\vec{OA} = \vec{a}, \vec{OB} = 10\vec{a} + 2\vec{b}$ and $\vec{OC} = \vec{b}$, where O, A and C are non-collinear points. Let p denotes the area of the quadrilateral $OABC$ and let q denotes, the area of the parallelogram with OA and OC as adjacent sides. If $p = kq$, then $k = \dots\dots$ (1997, 2M)

22. If the vectors $a\hat{i} + \hat{j} + \hat{k}, \hat{i} + b\hat{j} + \hat{k}$ and $\hat{i} + \hat{j} + c\hat{k}$ ($a \neq b \neq c \neq 1$) are coplanar, then the value of $\frac{1}{(1-a)} + \frac{1}{(1-b)} + \frac{1}{(1-c)} = \dots\dots$ (1987, 2M)

23. If $\vec{A}, \vec{B}, \vec{C}$ are three non-coplanar vectors, then

$$\frac{\vec{A} \cdot (\vec{B} \times \vec{C})}{(\vec{C} \times \vec{A}) \cdot \vec{B}} + \frac{\vec{B} \cdot (\vec{A} \times \vec{C})}{\vec{C} \cdot (\vec{A} \times \vec{B})} = \dots \quad (1985, 2M)$$

24. If $\begin{vmatrix} a & a^2 & 1+a^3 \\ b & b^2 & 1+b^3 \\ c & c^2 & 1+c^3 \end{vmatrix} = 0$ and the vectors

$\vec{A} = (1, a, a^2), \vec{B} = (1, b, b^2), \vec{C} = (1, c, c^2)$ are non-coplanar, then the product $abc = \dots$ (1985, 2M)

True/False

25. For any three vectors \vec{a}, \vec{b} and \vec{c} , $(\vec{a} - \vec{b}) \cdot \{(\vec{b} - \vec{c}) \times (\vec{c} - \vec{a})\} = 2\vec{a} \cdot (\vec{b} \times \vec{c})$ (1983, 1M)

26. If $\vec{X} \cdot \vec{A} = 0, \vec{X} \cdot \vec{B} = 0, \vec{X} \cdot \vec{C} = 0$ for some non-zero vector \vec{X} , then $[\vec{A} \ \vec{B} \ \vec{C}] = 0$. (1983, 1M)

Analytical & Descriptive Questions

27. If $\vec{u}, \vec{v}, \vec{w}$ are three non-coplanar unit vectors and α, β, γ are the angles between \vec{u} and \vec{v}, \vec{v} and \vec{w}, \vec{w} and \vec{u} respectively and $\vec{x}, \vec{y}, \vec{z}$ are unit vectors along the bisectors of the angles α, β, γ respectively. Prove that

$$[\vec{x} \times \vec{y} \cdot \vec{y} \times \vec{z} \cdot \vec{z} \times \vec{x}] = \frac{1}{16} [\vec{u} \cdot \vec{v} \cdot \vec{w}]^2 \sec^2 \frac{\alpha}{2} \sec^2 \frac{\beta}{2} \sec^2 \frac{\gamma}{2}$$

(2003, 4M)

28. Let V be the volume of the parallelepiped formed by the vectors

$$\vec{a} = a_1 \hat{i} + a_2 \hat{j} + a_3 \hat{k}, \vec{b} = b_1 \hat{i} + b_2 \hat{j} + b_3 \hat{k}$$

and $\vec{c} = c_1 \hat{i} + c_2 \hat{j} + c_3 \hat{k}$

If a_r, b_r, c_r , where $r = 1, 2, 3$ are non-negative real numbers and $\sum_{r=1}^3 (a_r + b_r + c_r) = 3L$. Show that $V \leq L^3$.

(2002, 5M)

29. Let \vec{u} and \vec{v} be unit vectors. If \vec{w} is a vector such that $\vec{w} + (\vec{w} \times \vec{u}) = \vec{v}$, then prove that $|(\vec{u} \times \vec{v}) \cdot \vec{w}| \leq \frac{1}{2}$ and that the equality holds if and only if \vec{u} is perpendicular to \vec{v} . (1999, 10M)

30. The position vectors of the points A, B, C and D are $3\hat{i} - 2\hat{j} - \hat{k}, 2\hat{i} + 3\hat{j} - 4\hat{k}, -\hat{i} + \hat{j} + 2\hat{k}$ and $4\hat{i} + 5\hat{j} + \lambda\hat{k}$, respectively. If the points A, B, C and D lie on a plane, find the value of λ . (1986, 2 $\frac{1}{2}$ M)

Integer & Numerical Answer Type Question

31. Let $\mathbf{a} = 2\hat{i} + \hat{j} - \hat{k}$ and $\mathbf{b} = \hat{i} + 2\hat{j} + \hat{k}$ be two vectors. Consider a vector $\mathbf{c} = \alpha\mathbf{a} + \beta\mathbf{b}$, $\alpha, \beta \in R$. If the projection of \mathbf{c} on the vector $(\mathbf{a} + \mathbf{b})$ is $3\sqrt{2}$, then the minimum value of $(\mathbf{c} - (\mathbf{a} \times \mathbf{b})) \cdot \mathbf{c}$ equals (2019 Adv.)

Topic 4 Vector Triple Product

Objective Questions I (Only one correct option)

1. Let $\mathbf{a} = \hat{i} - \hat{j}$, $\mathbf{b} = \hat{i} + \hat{j} + \hat{k}$ and \mathbf{c} be a vector such that $\mathbf{a} \times \mathbf{c} + \mathbf{b} = \mathbf{0}$ and $\mathbf{a} \cdot \mathbf{c} = 4$, then $|\mathbf{c}|^2$ is equal to

- (2019 Main, 9 Jan I)
- (a) 8 (b) $\frac{19}{2}$ (c) 9 (d) $\frac{17}{2}$

2. Let \mathbf{a}, \mathbf{b} and \mathbf{c} be three unit vectors, out of which vectors \mathbf{b} and \mathbf{c} are non-parallel. If α and β are the angles which vector \mathbf{a} makes with vectors \mathbf{b} and \mathbf{c} respectively and $\mathbf{a} \times (\mathbf{b} \times \mathbf{c}) = \frac{1}{2} \mathbf{b}$, then $|\alpha - \beta|$ is equal to

- (2019 Main, 12 Jan II)
- (a) 30° (b) 45° (c) 90° (d) 60°

3. Let $\hat{\mathbf{a}}, \hat{\mathbf{b}}$ and $\hat{\mathbf{c}}$ be three unit vectors such that $\hat{\mathbf{a}} \times (\hat{\mathbf{b}} \times \hat{\mathbf{c}}) = \frac{\sqrt{3}}{2} (\hat{\mathbf{b}} + \hat{\mathbf{c}})$. If $\hat{\mathbf{b}}$ is not parallel to $\hat{\mathbf{c}}$, then the angle between $\hat{\mathbf{a}}$ and $\hat{\mathbf{b}}$ is

- (2016 Main)
- (a) $\frac{3\pi}{4}$ (b) $\frac{\pi}{2}$
 (c) $\frac{2\pi}{3}$ (d) $\frac{5\pi}{6}$

4. Let $\vec{\mathbf{a}}, \vec{\mathbf{b}}$ and $\vec{\mathbf{c}}$ be three non-zero vectors such that no two of them are collinear and $(\vec{\mathbf{a}} \times \vec{\mathbf{b}}) \times \vec{\mathbf{c}} = \frac{1}{3} |\vec{\mathbf{b}}| |\vec{\mathbf{c}}| \vec{\mathbf{a}}$.

If θ is the angle between vectors $\vec{\mathbf{b}}$ and $\vec{\mathbf{c}}$, then a value of $\sin \theta$ is

- (a) $\frac{2\sqrt{2}}{3}$ (b) $\frac{-\sqrt{2}}{3}$ (c) $\frac{2}{3}$ (d) $\frac{-2\sqrt{3}}{3}$

5. The unit vector which is orthogonal to the vector $3\hat{i} + 2\hat{j} + 6\hat{k}$ and is coplanar with the vectors $2\hat{i} + \hat{j} + \hat{k}$ and $\hat{i} - \hat{j} + \hat{k}$ is

- (2004, 1M)
- (a) $\frac{2\hat{i} - 6\hat{j} + \hat{k}}{\sqrt{41}}$ (b) $\frac{2\hat{i} - 3\hat{j}}{\sqrt{13}}$
 (c) $\frac{3\hat{j} - \hat{k}}{\sqrt{10}}$ (d) $\frac{4\hat{i} + 3\hat{j} - 3\hat{k}}{\sqrt{34}}$

6. If $\vec{\mathbf{a}} = (\hat{i} + \hat{j} + \hat{k}), \vec{\mathbf{a}} \cdot \vec{\mathbf{b}} = 1$ and $\vec{\mathbf{a}} \times \vec{\mathbf{b}} = \hat{j} - \hat{k}$, then $\vec{\mathbf{b}}$ is equal to

- (2003, 1M)
- (a) $\hat{i} - \hat{j} + \hat{k}$ (b) $2\hat{j} - \hat{k}$
 (c) \hat{i} (d) $2\hat{i}$

7. Let the vectors $\vec{\mathbf{a}}, \vec{\mathbf{b}}, \vec{\mathbf{c}}$ and $\vec{\mathbf{d}}$ be such that $(\vec{\mathbf{a}} \times \vec{\mathbf{b}}) \times (\vec{\mathbf{c}} \times \vec{\mathbf{d}}) = \vec{\mathbf{0}}$. If P_1 and P_2 are planes determined by the pairs of vectors $\vec{\mathbf{a}}, \vec{\mathbf{b}}$, and $\vec{\mathbf{c}}, \vec{\mathbf{d}}$ respectively, then the angle between P_1 and P_2 is

- (2000, 2M)
- (a) 0 (b) $\pi/4$
 (c) $\pi/3$ (d) $\pi/2$

8. Let $\vec{\mathbf{a}} = 2\hat{i} + \hat{j} - 2\hat{k}$ and $\vec{\mathbf{b}} = \hat{i} + \hat{j}$. If $\vec{\mathbf{c}}$ is a vector such that $\vec{\mathbf{a}} \cdot \vec{\mathbf{c}} = |\vec{\mathbf{c}}|, |\vec{\mathbf{c}} - \vec{\mathbf{a}}| = 2\sqrt{2}$ and the angle between

- $(\vec{\mathbf{a}} \times \vec{\mathbf{b}})$ and $\vec{\mathbf{c}}$ is 30° , then $|(\vec{\mathbf{a}} \times \vec{\mathbf{b}}) \times \vec{\mathbf{c}}|$ is equal to
- (a) $\frac{2}{3}$ (b) $\frac{3}{2}$ (1999, 2M)
 (c) 2 (d) 3

9. If $\vec{a}, \vec{b}, \vec{c}$ are non-coplanar unit vectors such that $\vec{a} \times (\vec{b} \times \vec{c}) = \frac{(\vec{b} + \vec{c})}{\sqrt{2}}$, then the angle between \vec{a} and \vec{b} is
- (1995, 2M)
- (a) $\frac{3\pi}{4}$ (b) $\frac{\pi}{4}$
 (c) $\frac{\pi}{2}$ (d) π

Objective Question II

(One or more than one correct option)

10. The vector(s) which is/are coplanar with vectors $\hat{i} + \hat{j} + 2\hat{k}$ and $\hat{i} + 2\hat{j} + \hat{k}$, are perpendicular to the vector $\hat{i} + \hat{j} + \hat{k}$ is/are
- (2011)
- (a) $\hat{j} - \hat{k}$ (b) $-\hat{i} + \hat{j}$
 (c) $\hat{i} - \hat{j}$ (d) $-\hat{j} + \hat{k}$

Integer & Numerical Answer Type Questions

11. Let \mathbf{a}, \mathbf{b} and \mathbf{c} be three vectors such that $|\mathbf{a}| = \sqrt{3}, |\mathbf{b}| = 5, \mathbf{b} \cdot \mathbf{c} = 10$ and the angle between \mathbf{b} and \mathbf{c} is $\frac{\pi}{3}$. If \mathbf{a} is perpendicular to the vector $\mathbf{b} \times \mathbf{c}$, then $|\mathbf{a} \times (\mathbf{b} \times \mathbf{c})|$ is equal to
- (2020 Main, 9 Jan II)
12. If \vec{a} and \vec{b} are vectors in space given by $\vec{a} = \frac{\hat{i} - 2\hat{j}}{\sqrt{5}}$ and $\vec{b} = \frac{2\hat{i} + \hat{j} + 3\hat{k}}{\sqrt{14}}$, then the value of $(2\vec{a} + \vec{b}) \cdot [(\vec{a} \times \vec{b}) \times (\vec{a} - 2\vec{b})]$ is....
- (2010)
13. Consider the cube in the first octant with sides OP, OQ and OR of length 1, along the X -axis, Y -axis and Z -axis, respectively, where $O(0, 0, 0)$ is the origin. Let

$S\left(\frac{1}{2}, \frac{1}{2}, \frac{1}{2}\right)$ be the centre of the cube and T be the vertex of the cube opposite to the origin O such that S lies on the diagonal OT . If $\mathbf{p} = \mathbf{SP}, \mathbf{q} = \mathbf{SQ}, \mathbf{r} = \mathbf{SR}$ and $\mathbf{t} = \mathbf{ST}$, then the value of $|\mathbf{p} \times \mathbf{q} \times (\mathbf{r} \times \mathbf{t})|$ is

(2009)

Fill in the Blank

14. Let \vec{a}, \vec{b} and \vec{c} be three vectors having magnitudes 1, 1 and 2, respectively. If $\vec{a} \times (\vec{a} \times \vec{c}) + \vec{b} = \vec{0}$, then the acute angle between \vec{a} and \vec{c} is
- (1997, 2M)

Analytical & Descriptive Questions

15. If \vec{A}, \vec{B} and \vec{C} are vectors such that $|\vec{B}| = |\vec{C}|$. Prove that $[(\vec{A} + \vec{B}) \times (\vec{A} + \vec{C})] \times (\vec{B} \times \vec{C}) \cdot (\vec{B} + \vec{C}) = 0$.
- (1997, 5M)
16. If the vectors $\vec{b}, \vec{c}, \vec{d}$ are not coplanar, then prove that the vector $(\vec{a} \times \vec{b}) \times (\vec{c} \times \vec{d}) + (\vec{a} \times \vec{c}) \times (\vec{d} \times \vec{b}) + (\vec{a} \times \vec{d}) \times (\vec{b} \times \vec{c})$ is parallel to \vec{a} .
- (1994, 4M)
17. (i) If C is a given non-zero scalar and \vec{A} and \vec{B} be given non-zero vectors such that $\vec{A} \perp \vec{B}$, then find the vector \vec{X} which satisfies the equations $\vec{A} \cdot \vec{X} = C$ and $\vec{A} \times \vec{X} = \vec{B}$.
- (1983, 2M)
- (ii) A vector A has components A_1, A_2, A_3 in a right-handed rectangular cartesian coordinate system $OXYZ$. The coordinate system is rotated about the X -axis through an angle $\frac{\pi}{2}$. Find the components of A in the new coordinate system, in terms of A_1, A_2, A_3 .
- (1983, 2M)

Topic 5 Solving Equations and Reciprocal of Vectors

Objective Questions I (Only one correct option)

1. Let $\alpha = (\lambda - 2)\mathbf{a} + \mathbf{b}$ and $\beta = (4\lambda - 2)\mathbf{a} + 3\mathbf{b}$ be two given vectors where vectors \mathbf{a} and \mathbf{b} are non-collinear. The value of λ for which vectors α and β are collinear, is
- (2019 Main, 10 Jan II)
- (a) 4 (b) -3 (c) 3 (d) -4
2. Let $\mathbf{a} = 2\hat{i} + \lambda_1\hat{j} + 3\hat{k}$, $\mathbf{b} = 4\hat{i} + (3 - \lambda_2)\hat{j} + 6\hat{k}$ and $\mathbf{c} = 3\hat{i} + 6\hat{j} + (\lambda_3 - 1)\hat{k}$ be three vectors such that $\mathbf{b} = 2\mathbf{a}$ and \mathbf{a} is perpendicular to \mathbf{c} . Then a possible value of $(\lambda_1, \lambda_2, \lambda_3)$ is
- (2019 Main, 10 Jan I)
- (a) (1, 3, 1) (b) (1, 5, 1)
 (c) $\left(-\frac{1}{2}, 4, 0\right)$ (d) $\left(\frac{1}{2}, 4, -2\right)$

3. Let $\vec{a} = 2\hat{i} + \hat{j} + \hat{k}, \vec{b} = \hat{i} + 2\hat{j} - \hat{k}$ and a unit vector \vec{c} be coplanar. If \vec{c} is perpendicular to \vec{a} , then \vec{c} is equal to
- (1999, 2M)
- (a) $\frac{1}{\sqrt{2}}(-\hat{j} + \hat{k})$
 (b) $\frac{1}{\sqrt{3}}(-\hat{i} - \hat{j} - \hat{k})$
 (c) $\frac{1}{\sqrt{5}}(\hat{i} - 2\hat{j})$
 (d) $\frac{1}{\sqrt{5}}(\hat{i} - \hat{j} - \hat{k})$

556 Vectors

4. Let $\vec{p}, \vec{q}, \vec{r}$ be three mutually perpendicular vectors of the same magnitude. If a vector \vec{x} satisfies the equation

$$\vec{p} \times \left[(\vec{x} - \vec{q}) \times \vec{p} \right] + \vec{q} \times \left[(\vec{x} - \vec{r}) \times \vec{q} \right] + \vec{r} \times \left[(\vec{x} - \vec{p}) \times \vec{r} \right] = \vec{0}, \text{ then } \vec{x} \text{ is given by}$$

(1997C, 2M)

- (a) $\frac{1}{2}(\vec{p} + \vec{q} - 2\vec{r})$
 (b) $\frac{1}{2}(\vec{p} + \vec{q} + \vec{r})$
 (c) $\frac{1}{3}(\vec{p} + \vec{q} + \vec{r})$
 (d) $\frac{1}{3}(2\vec{p} + \vec{q} - \vec{r})$

Fill in the Blanks

5. A non-zero vector \vec{a} is parallel to the line of intersection of the plane determined by the vectors $\hat{i}, \hat{i} + \hat{j}$ and the plane determined by the vectors $\hat{i} - \hat{j}, \hat{i} + \hat{k}$. The angle between \vec{a} and the vector $\hat{i} - 2\hat{j} + 2\hat{k}$ is..... .
 (1996, 2M)
6. A unit vector coplanar with $\hat{i} + \hat{j} + 2\hat{k}$ and $\hat{i} + 2\hat{j} + \hat{k}$ and perpendicular to $\hat{i} + \hat{j} + \hat{k}$ is
 (1992, 2M)
7. Let $\vec{b} = 4\hat{i} + 3\hat{j}$ and \vec{c} be two vectors perpendicular to each other in the XY -plane. All vectors in the same plane having projections 1 and 2 along \vec{b} and \vec{c} , respectively are given by.... .
 (1987, 2M)
8. If $\vec{A} = (1, 1, 1), \vec{C} = (0, 1, -1)$ are given vectors, then a vector \vec{B} satisfying the equations $\vec{A} \times \vec{B} = \vec{C}$ and $\vec{A} \cdot \vec{B} = 3$ is
 (1985, 91, 2M)

Analytical & Descriptive Questions

9. Incident ray is along the unit vector \hat{v} and the reflected ray is along the unit vector \hat{w} . The normal is along unit vector \hat{a} outwards. Express \hat{w} in terms of \hat{a} and \hat{v} .
 (2005, 4M)

10. Let ABC and PQR be any two triangles in the same plane. Assume that the perpendiculars from the points A, B, C to the sides QR, RP, PQ respectively are concurrent. Using vector methods or otherwise, prove that the perpendiculars from P, Q, R to BC, CA, AB respectively are also concurrent.
 (2000, 4M)

11. The position vectors of the vertices A, B and C of a tetrahedron $ABCD$ are $\hat{i} + \hat{j} + \hat{k}, \hat{i}$ and $3\hat{i}$, respectively. The altitude from vertex D to the opposite face ABC meets the median line through A of the ΔABC at a point E . If the length of the side AD is 4 and the volume of the tetrahedron is $\frac{2\sqrt{2}}{3}$, then find the position vector of the point E for all its possible positions.
 (1996, 5M)

12. Prove, by vector methods or otherwise, that the point of intersection of the diagonals of a trapezium lies on the line passing through the mid-points of the parallel sides. (you may assume that the trapezium is not a parallelogram).
 (1998, 8M)

13. Let \vec{a}, \vec{b} and \vec{c} be non-coplanar unit vectors, equally inclined to one another at an angle θ . If $\vec{a} \times \vec{b} + \vec{b} \times \vec{c} = p\vec{a} + q\vec{b} + r\vec{c}$, then find scalars p, q and r in terms of θ .
 (1997C, 5M)

14. If $\vec{A} = 2\hat{i} + \hat{k}, \vec{B} = \hat{i} + \hat{j} + \hat{k}$ and $\vec{C} = 4\hat{i} - 3\hat{j} + 7\hat{k}$. Determine a vector \vec{R} satisfying $\vec{R} \times \vec{B} = \vec{C} \times \vec{B}$ and $\vec{R} \cdot \vec{A} = 0$.
 (1990, 3M)

15. If vectors $\vec{a}, \vec{b}, \vec{c}$ are coplanar, then show that

$$\begin{vmatrix} \vec{a} & \vec{b} & \vec{c} \\ \vec{a} \cdot \vec{a} & \vec{a} \cdot \vec{b} & \vec{a} \cdot \vec{c} \\ \vec{b} \cdot \vec{a} & \vec{b} \cdot \vec{b} & \vec{b} \cdot \vec{c} \end{vmatrix} = \vec{0}$$

(1989, 2M)

16. Find all values of λ , such that $x, y, z \neq (0, 0, 0)$ and $(\hat{i} + \hat{j} + 3\hat{k})x + (3\hat{i} - 3\hat{j} + \hat{k})y + (-4\hat{i} + 5\hat{j})z = \lambda(\hat{i}x + \hat{j}y + \hat{k}z)$, where $\hat{i}, \hat{j}, \hat{k}$ are unit vectors along the coordinate axes.
 (1982, 2M)

Answers

Topic 1

1. (a) 2. (d) 3. (a) 7. (b)
 4. (c) 5. (b) 6. (c) 8. (a)
 8. (a) 9. (a) 10. (a) 11. (b)
 12. (b) 13. (b) 14. (b) 15. (b)
 16. (b) 17. (a) 18. (a,c) 19. 3
20. $\left(\frac{\vec{a} \cdot \vec{b}}{|\vec{b}|^2}\right)\vec{b}$ and $\vec{a} - \left(\frac{\vec{a} \cdot \vec{b}}{|\vec{b}|^2}\right)\vec{b}$
21. Orthocentre 22. $5\sqrt{2}$ 23. False
24. $\vec{v}_1 = 2\hat{i}, \vec{v}_2 = -\hat{i} + \hat{j}$ and $\vec{v}_3 = 3\hat{i} \pm 2\hat{j} \pm 4\hat{k}$
25. $I = \frac{\alpha\vec{a} + \beta\vec{b} + \gamma\vec{c}}{\alpha + \beta + \gamma}$ 26. $\frac{8}{3}$ 27. $c \in \left(-\frac{4}{3}, 0\right)$
28. 3:2 29. (2:1) 30. (9) 31. (9) 32. (3)

Topic 2

1. (c) 2. (b) 3. (b) 4. (c)
 5. (b) 6. (d) 7. (c) 8. (b)
 9. (c) 10. (b) 11. (b) 12. (a,d)
 13. (a,c,d) 14. (b,d) 15. (c,d) 16. (108)
 17. (c) 18. (a)
19. (a) 20. \vec{a} 21. $\pm \frac{(2\hat{i} + \hat{j} + \hat{k})}{\sqrt{6}}$
22. $\sqrt{13}$ sq. units 23. True

Topic 3

1. (d) 2. (a) 3. (c) 4. (a)
 5. (c) 6. (c) 7. (c) 8. (c)

9. (a) 10. (c) 11. (d) 12. (d)
 13. (a) 14. (b) 15. (c) 16. (b)
 17. (d) 18. (a) 19. (b, c) 20. (a, c)
 21. (6) 22. (1) 23. (0) 24. (-1)
 25. True 26. True 30. $\frac{146}{17}$ 31. (18)

Topic 4

1. (b) 2. (a) 3. (d) 4. (a)
 5. (c) 6. (c) 7. (a) 8. (b)
 9. (a) 10. (a, d) 11. (30) 12. (5)
 13. (0.5) 14. $\frac{\pi}{6}$
17. (i) $\vec{X} = \left(\frac{\vec{c}}{|\vec{A}|^2}\right)\vec{A} - \left(\frac{1}{|\vec{A}|^2}\right)(\vec{A} \times \vec{B})$ (ii) $(A_2\hat{i} - A_1\hat{j} + A_3\hat{k})$

Topic 5

1. (d) 2. (c) 3. (a) 4. (b)
 5. $\frac{\pi}{4}$ or $\frac{3\pi}{4}$ 6. $\pm \frac{1}{\sqrt{2}}(-\hat{j} + \hat{k})$ 7. $(2\hat{i} - \hat{j})$
 8. $\left(\frac{5}{3}\hat{i}, \frac{2}{3}\hat{j}, \frac{2}{3}\hat{k}\right)$
 9. $\hat{w} = \hat{v} - 2(\hat{a} \cdot \hat{v})\hat{a}$
 11. $-\hat{i} + 3\hat{j} + 3\hat{k}$ and $3\hat{i} - \hat{j} - \hat{k}$
 13. $p = r = \frac{1}{\sqrt{1+2\cos\theta}}$, $q = \frac{-2\cos\theta}{\sqrt{1+2\cos\theta}}$
 14. $-\hat{i} - 8\hat{j} + 2\hat{k}$ 16. 0, -1

Hints & Solutions

Topic 1 Scalar Product of Two Vectors

1. **Key Idea** Use the angle between two non-zero vectors \mathbf{a} and \mathbf{b} is given by $\cos\theta = \frac{\mathbf{a} \cdot \mathbf{b}}{|\mathbf{a}||\mathbf{b}|}$ and coordinates of the centroid i.e. $\left(\frac{x_1 + x_2 + x_3}{3}, \frac{y_1 + y_2 + y_3}{3}, \frac{z_1 + z_2 + z_3}{3}\right)$ of a triangle formed with vertices; $(x_1, y_1, z_1), (x_2, y_2, z_2)$ and (x_3, y_3, z_3) .

Given vertices of a $\triangle ABC$ are $A(3, 0, -1)$, $B(2, 10, 6)$ and $C(1, 2, 1)$ and a point M is mid-point of AC . An another point G divides BM in ratio $2 : 1$, so G is the centroid of $\triangle ABC$.

$$\therefore G\left(\frac{3+2+1}{3}, \frac{0+10+2}{3}, \frac{-1+6+1}{3}\right) = (2, 4, 2).$$

Now, $\cos(\angle GOA) = \frac{\mathbf{OG} \cdot \mathbf{OA}}{|\mathbf{OG}||\mathbf{OA}|}$, where O is the origin.

$$\therefore \mathbf{OG} = 2\hat{i} + 4\hat{j} + 2\hat{k} \Rightarrow |\mathbf{OG}| = \sqrt{4+16+4} = \sqrt{24}$$

$$\text{and } |\mathbf{OA}| = |3\hat{i} - \hat{k}| \Rightarrow |\mathbf{OA}| = \sqrt{9+1} = \sqrt{10}$$

$$\text{and } \mathbf{OG} \cdot \mathbf{OA} = 6 - 2 = 4$$

$$\therefore \cos(\angle GOA) = \frac{4}{\sqrt{24}\sqrt{10}} = \frac{1}{\sqrt{15}}$$

2. Given unit vector \mathbf{a} makes an angle $\frac{\pi}{3}$ with \hat{i} , $\frac{\pi}{4}$ with \hat{j} and $\theta \in (0, \pi)$ with \hat{k} .

Now, we know that $\cos^2\alpha + \cos^2\beta + \cos^2\gamma = 1$, where α, β, γ are angles made by the vectors with respectively \hat{i}, \hat{j} and \hat{k} .

$$\therefore \cos^2\left(\frac{\pi}{3}\right) + \cos^2\left(\frac{\pi}{4}\right) + \cos^2\theta = 1$$

$$\Rightarrow \frac{1}{4} + \frac{1}{2} + \cos^2\theta = 1 \Rightarrow \cos^2\theta = \frac{1}{4} \Rightarrow \cos\theta = \pm \frac{1}{2}$$

$$\Rightarrow \cos\theta = \cos\left(\frac{\pi}{3}\right) \text{ or } \cos\left(\frac{2\pi}{3}\right)$$

$$\Rightarrow \theta = \frac{\pi}{3} \text{ or } \frac{2\pi}{3}$$

So, θ is $\frac{2\pi}{3}$, according to options.

3. According to given information, we have the following figure.

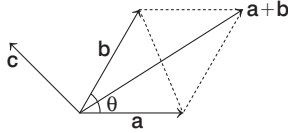

Clearly, projection of b on $a = \frac{b \cdot a}{|a|}$

$$= \frac{(b_1\hat{i} + b_2\hat{j} + \sqrt{2}\hat{k}) \cdot (\hat{i} + \hat{j} + \sqrt{2}\hat{k})}{\sqrt{1^2 + 1^2 + (\sqrt{2})^2}}$$

$$= \frac{b_1 + b_2 + 2}{\sqrt{4}} = \frac{b_1 + b_2 + 2}{2}$$

But projection of b on $a = |a|$

$$\therefore \frac{b_1 + b_2 + 2}{2} = \sqrt{1^2 + 1^2 + (\sqrt{2})^2}$$

$$\Rightarrow \frac{b_1 + b_2 + 2}{2} = 2 \Rightarrow b_1 + b_2 = 2 \quad \dots(i)$$

Now, $a + b = (\hat{i} + \hat{j} + \sqrt{2}\hat{k}) + (b_1\hat{i} + b_2\hat{j} + \sqrt{2}\hat{k})$

$$= (b_1 + 1)\hat{i} + (b_2 + 1)\hat{j} + 2\sqrt{2}\hat{k}$$

$\therefore (a + b) \perp c$, therefore $(a + b) \cdot c = 0$

$$\Rightarrow \{(b_1 + 1)\hat{i} + (b_2 + 1)\hat{j} + 2\sqrt{2}\hat{k}\} \cdot (5\hat{i} + \hat{j} + \sqrt{2}\hat{k}) = 0$$

$$\Rightarrow 5(b_1 + 1) + 1(b_2 + 1) + 2\sqrt{2}(\sqrt{2}) = 0$$

$$\Rightarrow 5b_1 + b_2 = -10 \quad \dots(ii)$$

From Eqs. (i) and (ii), $b_1 = -3$ and $b_2 = 5$

$$\Rightarrow b = -3\hat{i} + 5\hat{j} + \sqrt{2}\hat{k}$$

$$\Rightarrow |b| = \sqrt{(-3)^2 + (5)^2 + (\sqrt{2})^2} = \sqrt{36} = 6$$

4. Let 1st line is $x = ay + b, z = cy + d$.
- $$\Rightarrow \frac{x-b}{a} = y, \frac{z-d}{c} = y \Rightarrow \frac{x-b}{a} = y = \frac{z-d}{c}$$

The direction vector of this line is $b_1 = a\hat{i} + \hat{j} + c\hat{k}$.

Let 2nd line is $x = a'z + b', y = c'z + d'$.

$$\Rightarrow \frac{x-b'}{a'} = z, \frac{y-d'}{c'} = z \Rightarrow \frac{x-b'}{a'} = \frac{y-d'}{c'} = z$$

The direction vector of this line is $b_2 = a'\hat{i} + c'\hat{j} + \hat{k}$.

\therefore The two lines are perpendicular, therefore, $b_1 \cdot b_2 = 0$.

$$\Rightarrow (a\hat{i} + \hat{j} + c\hat{k}) \cdot (a'\hat{i} + c'\hat{j} + \hat{k}) = 0$$

$$\Rightarrow aa' + c' + c = 0 \Rightarrow aa' + c + c' = 0$$

5. $OP \cdot OQ + OR \cdot OS = OR \cdot OP + OQ \cdot OS$
- $$\Rightarrow OP(OQ - OR) + OS(OR - OQ) = 0$$
- $$\Rightarrow (OP - OS)(OQ - OR) = 0$$
- $$\Rightarrow SP \cdot RQ = 0$$

Similarly $SR \cdot PQ = 0$ and $SQ \cdot PR = 0$

$\therefore S$ is orthocentre.

6. Let $\vec{v} = \vec{a} + \lambda \vec{b}$

$$\vec{v} = (1 + \lambda)\hat{i} + (1 - \lambda)\hat{j} + (1 + \lambda)\hat{k}$$

Projection of \vec{v} on $\vec{c} = \frac{1}{\sqrt{3}} \Rightarrow \frac{\vec{v} \cdot \vec{c}}{|\vec{c}|} = \frac{1}{\sqrt{3}}$

$$\Rightarrow \frac{(1 + \lambda) - (1 - \lambda) - (1 + \lambda)}{\sqrt{3}} = \frac{1}{\sqrt{3}}$$

$$\Rightarrow 1 + \lambda - 1 + \lambda - 1 - \lambda = 1$$

$$\Rightarrow \lambda - 1 = 1$$

$$\Rightarrow \lambda = 2$$

$$\therefore \vec{v} = 3\hat{i} - \hat{j} + 3\hat{k}$$

7. $\vec{AB} = 2\hat{i} + 10\hat{j} + 11\hat{k}$,

$$\vec{AD} = -\hat{i} + 2\hat{j} + 2\hat{k}$$

Angle ' θ ' between \vec{AB} and \vec{AD} is

$$\cos(\theta) = \left| \frac{\vec{AB} \cdot \vec{AD}}{|\vec{AB}| |\vec{AD}|} \right| = \left| \frac{-2 + 20 + 22}{(15)(3)} \right| = \frac{8}{9}$$

$$\Rightarrow \sin(\theta) = \frac{\sqrt{17}}{9}$$

Since, $\alpha + \theta = 90^\circ$

$$\therefore \cos(\alpha) = \cos(90^\circ - \theta) = \sin(\theta) = \frac{\sqrt{17}}{9}$$

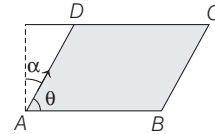

8. $m_{PQ} = \frac{1}{6}, m_{SR} = \frac{1}{6}, m_{RQ} = -3, m_{SP} = -3$

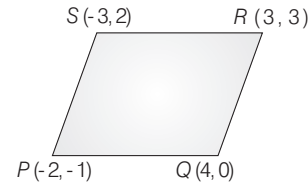

\Rightarrow Parallelogram, but neither $PR = SQ$ nor $PR \perp SQ$.

\therefore So, it is a parallelogram, which is neither a rhombus nor a rectangle.

9. Given, $\vec{OP} = \hat{a} \cos t + \hat{b} \sin t$

$$\Rightarrow |\vec{OP}| = \sqrt{(\hat{a} \cdot \hat{a}) \cos^2 t + (\hat{b} \cdot \hat{b}) \sin^2 t + 2\hat{a} \cdot \hat{b} \sin t \cos t}$$

$$\Rightarrow |\vec{OP}| = \sqrt{1 + \hat{a} \cdot \hat{b} \sin 2t}$$

$$\Rightarrow |\vec{OP}|_{\max} = M = \sqrt{1 + \hat{a} \cdot \hat{b}} \text{ at } \sin 2t = 1 \Rightarrow t = \frac{\pi}{4}$$

At $t = \frac{\pi}{4}, \vec{OP} = \frac{1}{\sqrt{2}} (\hat{a} + \hat{b})$

Unit vector along \vec{OP} at $\left(t = \frac{\pi}{4}\right) = \frac{\hat{a} + \hat{b}}{|\hat{a} + \hat{b}|}$

10. Let vector \vec{r} be coplanar to \vec{a} and \vec{b} .
 $\therefore \vec{r} = \vec{a} + t\vec{b}$
 $\Rightarrow \vec{r} = (\hat{i} + 2\hat{j} + \hat{k}) + t(\hat{i} - \hat{j} + \hat{k})$
 $= \hat{i}(1+t) + \hat{j}(2-t) + \hat{k}(1+t)$
 The projection of \vec{r} on $\vec{c} = \frac{1}{\sqrt{3}}$. [given]
 $\Rightarrow \frac{\vec{r} \cdot \vec{c}}{|\vec{c}|} = \frac{1}{\sqrt{3}}$
 $\Rightarrow \frac{|1 \cdot (1+t) + 1 \cdot (2-t) - 1 \cdot (1+t)|}{\sqrt{3}} = \frac{1}{\sqrt{3}}$
 $\Rightarrow (2-t) = \pm 1 \Rightarrow t = 1 \text{ or } 3$
 When, $t = 1$, we have $\vec{r} = 2\hat{i} + \hat{j} + 2\hat{k}$
 When, $t = 3$, we have $\vec{r} = 4\hat{i} - \hat{j} + 4\hat{k}$

11. Since, $\vec{b}_1 = \vec{b} - \frac{\vec{b} \cdot \vec{a}}{|\vec{a}|^2} \vec{a}$, $\vec{b}_1 = \vec{b} + \frac{\vec{b} \cdot \vec{a}}{|\vec{a}|^2} \vec{a}$
 and $\vec{c}_1 = \vec{c} - \frac{\vec{c} \cdot \vec{a}}{|\vec{a}|^2} \vec{a} - \frac{\vec{c} \cdot \vec{b}}{|\vec{b}|^2} \vec{b}$, $\vec{c}_2 = \vec{c} - \frac{\vec{c} \cdot \vec{a}}{|\vec{a}|^2} \vec{a} - \frac{\vec{c} \cdot \vec{b}_1}{|\vec{b}_1|^2} \vec{b}_1$
 $\vec{c}_3 = \vec{c} - \frac{\vec{c} \cdot \vec{a}}{|\vec{a}|^2} \vec{a} - \frac{\vec{c} \cdot \vec{b}_2}{|\vec{b}_2|^2} \vec{b}_2$, $\vec{c}_4 = \vec{a} - \frac{\vec{c} \cdot \vec{a}}{|\vec{a}|^2} \vec{a}$
 which shows $\vec{a} \cdot \vec{b}_1 = 0 = \vec{a} \cdot \vec{c}_2 = \vec{b}_1 \cdot \vec{c}_2$
 So, $\{\vec{a}, \vec{b}_1, \vec{c}_2\}$ are mutually orthogonal vectors.

12. Since, $(\vec{a} + 2\vec{b}) \cdot (5\vec{a} - 4\vec{b}) = 0$
 $\Rightarrow 5|\vec{a}|^2 + 6\vec{a} \cdot \vec{b} - 8|\vec{b}|^2 = 0$
 $\Rightarrow 6\vec{a} \cdot \vec{b} = 3$ [$\because |\vec{a}| = |\vec{b}| = 1$]
 $\Rightarrow \cos \theta = \frac{1}{2} \Rightarrow \theta = 60^\circ$

13. Now, $(\vec{a} + \vec{b} + \vec{c})^2 = \Sigma \vec{a}^2 + 2\Sigma \vec{a} \cdot \vec{b} \geq 0$
 $\Rightarrow 2\Sigma \vec{a} \cdot \vec{b} \geq -3$ [$\because |\vec{a}| = |\vec{b}| = |\vec{c}| = 1$]
 Now, $\Sigma |\vec{a} - \vec{b}|^2 = 2\Sigma \vec{a}^2 - 2\Sigma \vec{a} \cdot \vec{b} \leq 2(3) + 3 = 9$

14. Since, $\vec{u} + \vec{v} + \vec{w} = \vec{0} \Rightarrow |\vec{u} + \vec{v} + \vec{w}|^2 = 0$
 $\Rightarrow |\vec{u}|^2 + |\vec{v}|^2 + |\vec{w}|^2 + 2(\vec{u} \cdot \vec{v} + \vec{v} \cdot \vec{w} + \vec{w} \cdot \vec{u}) = 0$
 $\Rightarrow 9 + 16 + 25 + 2(\vec{u} \cdot \vec{v} + \vec{v} \cdot \vec{w} + \vec{w} \cdot \vec{u}) = 0$
 $\Rightarrow \vec{u} \cdot \vec{v} + \vec{v} \cdot \vec{w} + \vec{w} \cdot \vec{u} = -25$

15. A vector perpendicular to \vec{a} and \vec{b} is $\pm \frac{(\vec{a} \times \vec{b})}{|\vec{a} \times \vec{b}|}$.

16. Here, $\vec{a} = (2p)\hat{i} + \hat{j}$, when a system is rotated, the new component of \vec{a} are $(p+1)$ and 1 .
 i.e. $\vec{b} = (p+1)\hat{i} + \hat{j} \Rightarrow |\vec{a}|^2 = |\vec{b}|^2$

or $4p^2 + 1 = (p+1)^2 + 1 \Rightarrow 4p^2 = p^2 + 2p + 1$
 $\Rightarrow 3p^2 - 2p - 1 = 0 \Rightarrow (3p+1)(p-1) = 0$
 $\Rightarrow p = 1, -1/3$

17. Three points A, B, C are collinear, if $\vec{AB} = -20\hat{i} - 11\hat{j}$
 and $\vec{AC} = (a-60)\hat{i} - 55\hat{j}$, then $\vec{AB} \parallel \vec{AC}$
 $\Rightarrow \frac{a-60}{-20} = \frac{-55}{-11} \Rightarrow a = -40$

18. Given vectors are $\vec{a} = 2\hat{i} - \hat{j} + \hat{k}$, $\vec{b} = \hat{i} + 2\hat{j} - \hat{k}$ and $\vec{c} = \hat{i} + \hat{j} - 2\hat{k}$. Any vector \vec{r} in the plane of \vec{b} and \vec{c} is
 $\vec{r} = \vec{b} + t\vec{c} = \hat{i} + 2\hat{j} - \hat{k} + t(\hat{i} + \hat{j} - 2\hat{k})$
 $= (1+t)\hat{i} + (2+t)\hat{j} - (1+2t)\hat{k}$... (i)

Since, projection of \vec{r} on \vec{a} is $\frac{\vec{r} \cdot \vec{a}}{|\vec{a}|}$

$\therefore \frac{\vec{r} \cdot \vec{a}}{|\vec{a}|} = \frac{\sqrt{2}}{\sqrt{3}}$
 $\Rightarrow \left| \frac{2(1+t) - (2+t) - (1+2t)}{\sqrt{6}} \right| = \frac{\sqrt{2}}{\sqrt{3}}$
 $\Rightarrow |-(1+t)| = 2$
 $\Rightarrow t = 1 \text{ or } -3$

On putting $t = 1, -3$ in Eq. (i) respectively, we get

$\vec{r} = 2\hat{i} + 3\hat{j} - 3\hat{k}$

or $\vec{r} = -2\hat{i} - \hat{j} + 5\hat{k}$

19. We have, $\vec{c} = x\vec{a} + y\vec{b} + \vec{a} \times \vec{b}$ and $\vec{a} \cdot \vec{b} = 0$
 $|\vec{a}| = |\vec{b}| = 1$ and $|\vec{c}| = 2$

Also, given \vec{c} is inclined on \vec{a} and \vec{b} with same angle α .

$\therefore \vec{a} \cdot \vec{c} = x|\vec{a}|^2 + y(\vec{a} \cdot \vec{b}) + \vec{a} \cdot (\vec{a} \times \vec{b})$
 $|\vec{a}| |\vec{c}| \cos \alpha = x + 0 + 0$
 $x = 2 \cos \alpha$

Similarly,

$|\vec{b}| |\vec{c}| \cos \alpha = 0 + y + 0$
 $\Rightarrow y = 2 \cos \alpha$
 $|\vec{c}|^2 = x^2 + y^2 + |\vec{a} \times \vec{b}|^2$

$4 = 8 \cos^2 \alpha + |a|^2 |b|^2 \sin^2 90^\circ$
 $4 = 8 \cos^2 \alpha + 1$
 $\Rightarrow 8 \cos^2 \alpha = 3$

560 Vectors

20. Vector component of \vec{a} along and perpendicular to \vec{b} are

$$\left(\frac{\vec{a} \cdot \vec{b}}{|\vec{b}|^2}\right)\vec{b} \quad \text{and} \quad \vec{a} - \left(\frac{\vec{a} \cdot \vec{b}}{|\vec{b}|^2}\right)\vec{b}$$

21. As, $(\vec{a} - \vec{d}) \cdot (\vec{b} - \vec{c}) = (\vec{b} - \vec{d}) \cdot (\vec{c} - \vec{a}) = 0$
 $\Rightarrow AD \perp BC$ and $BD \perp CA$
 which clearly represents from figure that D is orthocentre of $\triangle ABC$.

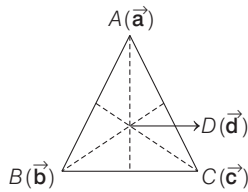

22. Given, $|\vec{A}| = 3, |\vec{B}| = 4, |\vec{C}| = 5$

$$\text{Since, } \vec{A} \cdot (\vec{B} + \vec{C}) = \vec{B} \cdot (\vec{C} + \vec{A}) = \vec{C} \cdot (\vec{A} + \vec{B}) = 0 \quad \dots (i)$$

$$\begin{aligned} \therefore |\vec{A} + \vec{B} + \vec{C}|^2 &= |\vec{A}|^2 + |\vec{B}|^2 + |\vec{C}|^2 \\ &\quad + 2(\vec{A} \cdot \vec{B} + \vec{B} \cdot \vec{C} + \vec{C} \cdot \vec{A}) \\ &= 9 + 16 + 25 + 0 \\ &\quad [\text{from Eq. (i), } \vec{A} \cdot \vec{B} + \vec{B} \cdot \vec{C} + \vec{C} \cdot \vec{A} = 0] \\ \therefore |\vec{A} + \vec{B} + \vec{C}|^2 &= 50 \\ \Rightarrow |\vec{A} + \vec{B} + \vec{C}| &= 5\sqrt{2} \end{aligned}$$

23. Let position vectors of points \vec{A}, \vec{B} and \vec{C} be $\vec{a} + \vec{b}, \vec{a} - \vec{b}$ and $\vec{a} + k\vec{b}$, respectively.

$$\begin{aligned} \therefore (\vec{a} - \vec{b}) - (\vec{a} + \vec{b}) &= (\vec{a} + k\vec{b}) - (\vec{a} - \vec{b}) \\ \Rightarrow -2\vec{b} &= (k+1)\vec{b} \\ \Rightarrow k+1 &= -2 \\ \Rightarrow k &= -3 \end{aligned}$$

Hence, it is false statement.

24. We have, $|\vec{v}_1| = 2, |\vec{v}_2| = \sqrt{2}$ and $|\vec{v}_3| = \sqrt{29}$

If θ is the angle between \vec{v}_1 and \vec{v}_2 , then

$$\begin{aligned} 2\sqrt{2} \cos \theta &= -2 \\ \Rightarrow \cos \theta &= -\frac{1}{\sqrt{2}} \\ \Rightarrow \theta &= 135^\circ \end{aligned}$$

Since, any two vectors are always coplanar and data is not sufficient, so we can assume \vec{v}_1 and \vec{v}_2 in $x-y$ plane.

$$\vec{v}_1 = 2\hat{i} \quad [\text{let}]$$

$$\vec{v}_2 = -\hat{i} + \hat{j}$$

$$\text{and } \vec{v}_3 = \alpha \hat{i} + \beta \hat{j} + \gamma \hat{k}$$

$$\text{Since, } \vec{v}_3 \cdot \vec{v}_1 = 6 = 2\alpha \Rightarrow \alpha = 3$$

$$\text{Also, } \vec{v}_3 \cdot \vec{v}_2 = -5 = -\alpha + \beta$$

$$\Rightarrow \beta = \pm 2$$

$$\text{and } \vec{v}_3 \cdot \vec{v}_3 = 29 = \alpha^2 + \beta^2 + \gamma^2 \Rightarrow \gamma = \pm 4$$

$$\text{Hence, } \vec{v}_3 = 3\hat{i} \pm 2\hat{j} \pm 4\hat{k}$$

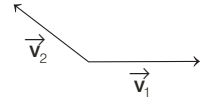

25. Let AD be the angular bisector of angle A . Let BC, AC and AB are α, β and γ , respectively. Then, $\frac{BD}{DC} = \frac{\gamma}{\beta}$.

Hence, position vector of $D = \frac{\gamma \vec{c} + \beta \vec{b}}{\gamma + \beta}$. On AD , there lies a point I which divides it in ratio $\gamma + \beta : \alpha$.

$$\text{Now, position vector of } I = \frac{\alpha \vec{a} + \beta \vec{b} + \gamma \vec{c}}{\alpha + \beta + \gamma}$$

which is symmetric in $\vec{a}, \vec{b}, \vec{c}, \alpha, \beta$ and γ .

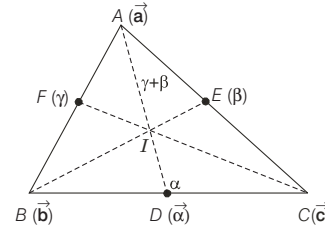

Hence I lies on every angle bisector and angle bisectors are concurrent.

$$\text{Here, } \alpha = |\vec{b} - \vec{c}|, \beta = |\vec{a} - \vec{c}|, \gamma = |\vec{a} - \vec{b}|.$$

26. Let the position vectors of A, B and C are \vec{a}, \vec{b} and \vec{c} respectively, since the point D divides BC in the ratio of $2:1$, the position vector of D will be

$$D \equiv \left(\frac{2\vec{c} + \vec{b}}{3}\right)$$

and the point E divides AC in the ratio $3:1$,

$$\text{therefore } E \equiv \left(\frac{3\vec{c} + \vec{a}}{4}\right).$$

Now, let P divides BE in the ratio $l:m$ and AD in the ratio $x:y$.

Hence, the position vector of P getting from BE and AD must be the same.

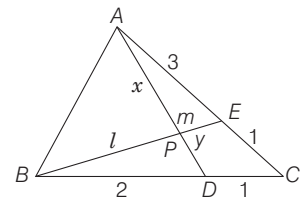

Hence, we have

$$\frac{l\left(\frac{3\vec{c}+\vec{a}}{4}\right)+m\vec{b}}{l+m} = \frac{x\left(\frac{2\vec{c}+\vec{b}}{3}\right)+y\vec{a}}{x+y}$$

$$\Rightarrow \frac{\frac{3l\vec{c}}{4} + \frac{l\vec{a}}{4} + m\vec{b}}{l+m} = \frac{\frac{2\vec{c}x}{3} + \frac{\vec{b}x}{3} + y\vec{a}}{x+y}$$

$$\Rightarrow \frac{3l}{4(l+m)}\vec{c} + \frac{l}{4(l+m)}\vec{a} + \frac{m\vec{b}}{l+m}$$

$$= \frac{2x}{3(x+y)}\vec{c} + \frac{x}{3(x+y)}\vec{b} + \frac{y}{(x+y)}\vec{a}$$

Now, comparing the coefficients, we get

$$\frac{3l}{4(l+m)} = \frac{2x}{3(x+y)} \quad \dots(i)$$

$$\frac{l}{4(l+m)} = \frac{y}{x+y}, \quad \dots(ii)$$

and

$$\frac{m}{l+m} = \frac{x}{3(x+y)} \quad \dots(iii)$$

On dividing Eq. (i) by Eq. (iii), we get

$$\frac{\frac{3l}{4(l+m)}}{\frac{m}{l+m}} = \frac{\frac{2x}{3(x+y)}}{\frac{x}{3(x+y)}}$$

$$\Rightarrow \frac{3}{4} \cdot \frac{l}{m} = 2$$

$$\Rightarrow \frac{l}{m} = \frac{8}{3} = \frac{BP}{PE}$$

27. Let $\vec{a} = c\hat{i} - 6\hat{j} + 3\hat{k}$ and $\vec{b} = x\hat{i} + 2\hat{j} + 2cx\hat{k}$. Since, \vec{a} and \vec{b} makes an obtuse angle.

$$\Rightarrow \vec{a} \cdot \vec{b} < 0 \Rightarrow cx^2 - 12 + 6cx < 0$$

$$\Rightarrow c < 0 \text{ and discriminant} < 0$$

$$\Rightarrow c < 0 \text{ and } 36c^2 - 4 \cdot (-12)c < 0$$

$$\Rightarrow c < 0 \text{ and } 12c(3c+4) < 0$$

$$\Rightarrow c < 0 \text{ and } c > -4/3$$

$$\therefore c \in (-4/3, 0)$$

28. Let O be origin and $\vec{OA} = \vec{a}, \vec{OB} = \vec{b}$

$$\vec{OE} = \frac{\vec{b}}{2} \quad [\text{since } E \text{ being mid-point of } \vec{OB}]$$

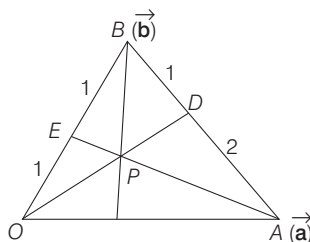

$$\vec{OD} = \frac{\vec{a} \cdot 1 + \vec{b} \cdot 2}{1+2}$$

(since, D divides \vec{AB} in the ratio of $2 : 1$)

$$\Rightarrow \text{Equation of } \vec{OD} \text{ is } \vec{r} = t \left(\frac{\vec{a} + 2\vec{b}}{3} \right)$$

$$\text{and equation of } \vec{AE} \text{ is } \vec{r} = \vec{a} + s \left(\frac{\vec{b}}{2} - \vec{a} \right)$$

If \vec{OD} and \vec{AE} intersect at P , then there must be some \vec{r} for which they are equal.

$$\Rightarrow t \left(\frac{\vec{a} + 2\vec{b}}{3} \right) = \vec{a} + s \left(\frac{\vec{b}}{2} - \vec{a} \right)$$

$$\Rightarrow \frac{t}{3} = 1 - s \text{ and } \frac{2t}{3} = \frac{s}{2}$$

$$\Rightarrow t = \frac{3}{5} \text{ and } s = \frac{4}{5}$$

$$\therefore \text{Point } P \text{ is } \frac{\vec{a} + 2\vec{b}}{5}. \quad \dots(i)$$

Since, P divides \vec{OD} in the ratio of $\lambda : 1$.

$$\lambda \left(\frac{\vec{a} + 2\vec{b}}{3} \right) + 1 \cdot 0 = \left(\frac{\vec{a} + 2\vec{b}}{5} \right) \quad \dots(ii)$$

From Eqs. (i) and (ii),

$$\frac{\lambda}{3(\lambda+1)} = \frac{1}{5}$$

$$\Rightarrow 5\lambda = 3\lambda + 3$$

$$\Rightarrow \lambda = \frac{3}{2}$$

$$\therefore \frac{OP}{PD} = \frac{3}{2}$$

29. $OACB$ is a parallelogram with O as origin. Let

$$\vec{OA} = \vec{a}, \vec{OB} = \vec{b}, \vec{OC} = \vec{a} + \vec{b}$$

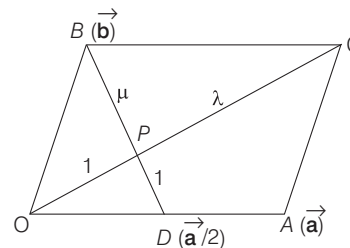

and
$$\vec{OD} = \frac{\vec{a}}{2}$$

562 Vectors

\vec{CO} and \vec{BD} meets at P .

$$\therefore \vec{OP} = \frac{\lambda \cdot 0 + 1(\vec{a} + \vec{b})}{\lambda + 1} \quad [\text{along } \vec{OC}]$$

$$\Rightarrow \vec{OP} = \frac{\vec{a} + \vec{b}}{\lambda + 1} \quad \dots(i)$$

$$\text{Again, } \vec{OP} = \frac{\mu \left(\frac{\vec{a}}{2} \right) + 1(\vec{b})}{\mu + 1} \quad [\text{along } \vec{BD}]$$

$$\Rightarrow \vec{OP} = \frac{\mu \vec{a} + 2\vec{b}}{2(\mu + 1)} \quad \dots(ii)$$

From Eqs. (i) and (ii),

$$\frac{\vec{a} + \vec{b}}{\lambda + 1} = \frac{\mu \vec{a} + 2\vec{b}}{2(\mu + 1)} \Rightarrow \frac{1}{\lambda + 1} = \frac{\mu}{2(\mu + 1)} \text{ and } \frac{1}{\lambda + 1} = \frac{1}{\mu + 1}$$

On solving, we get $\mu = \lambda = 2$

Thus, required ratio is $2 : 1$.

30. $\vec{A}(t)$ is parallel to $\vec{B}(t)$ for some $t \in [0, 1]$, if and only if $\frac{f_1(t)}{g_1(t)} = \frac{f_2(t)}{g_2(t)}$ for some $t \in [0, 1]$

or $f_1(t) \cdot g_2(t) = f_2(t) \cdot g_1(t)$ for some $t \in [0, 1]$

Let $h(t) = f_1(t) \cdot g_2(t) - f_2(t) \cdot g_1(t)$

$$\therefore h(0) = 2 \times 2 - 3 \times 3 = -5 < 0$$

$$\text{and } h(1) = f_1(1) \cdot g_2(1) - f_2(1) \cdot g_1(1)$$

$$= 6 \times 6 - 2 \times 2 = 32 > 0$$

Since, h is a continuous function and $h(0) \cdot h(1) < 0$,

Therefore, here is some $t \in [0, 1]$ for which $h(t) = 0$,

i.e. $\vec{A}(t)$ and $\vec{B}(t)$ are parallel vectors for this t .

31. Here, $\mathbf{s} = 4\mathbf{p} + 3\mathbf{q} + 5\mathbf{r}$... (i)

$$\text{and } \mathbf{s} = (-\mathbf{p} + \mathbf{q} + \mathbf{r})x + (\mathbf{p} - \mathbf{q} + \mathbf{r})y + (-\mathbf{p} - \mathbf{q} + \mathbf{r})z \quad \dots(ii)$$

$$\therefore 4\mathbf{p} + 3\mathbf{q} + 5\mathbf{r} = \mathbf{p}(-x + y - z) + \mathbf{q}(x - y - z) + \mathbf{r}(x + y + z)$$

On comparing both sides, we get

$$-x + y - z = 4, \quad x - y - z = 3 \text{ and } x + y + z = 5$$

On solving above equations, we get

$$x = 4, \quad y = \frac{9}{2}, \quad z = \frac{-7}{2}$$

$$\therefore 2x + y + z = 8 + \frac{9}{2} - \frac{7}{2} = 9$$

32. **PLAN** If a, b, c are any three vectors

Then $|\vec{a} + \vec{b} + \vec{c}|^2 \geq 0$

$$\Rightarrow |\vec{a}|^2 + |\vec{b}|^2 + |\vec{c}|^2 + 2(\vec{a} \cdot \vec{b} + \vec{b} \cdot \vec{c} + \vec{c} \cdot \vec{a}) \geq 0$$

$$\therefore \vec{a} \cdot \vec{b} + \vec{b} \cdot \vec{c} + \vec{c} \cdot \vec{a} \geq \frac{-1}{2}(|\vec{a}|^2 + |\vec{b}|^2 + |\vec{c}|^2)$$

Given, $|\vec{a} - \vec{b}|^2 + |\vec{b} - \vec{c}|^2 + |\vec{c} - \vec{a}|^2 = 9$

$$\Rightarrow |\vec{a}|^2 + |\vec{b}|^2 - 2\vec{a} \cdot \vec{b} + |\vec{b}|^2 + |\vec{c}|^2 - 2\vec{b} \cdot \vec{c} + |\vec{c}|^2 + |\vec{a}|^2 - 2\vec{c} \cdot \vec{a} = 9$$

$$\Rightarrow 6 - 2(\vec{a} \cdot \vec{b} + \vec{b} \cdot \vec{c} + \vec{c} \cdot \vec{a}) = 9 \quad [\because |\vec{a}| = |\vec{b}| = |\vec{c}| = 1]$$

$$\Rightarrow \vec{a} \cdot \vec{b} + \vec{b} \cdot \vec{c} + \vec{c} \cdot \vec{a} = -\frac{3}{2} \quad \dots(i)$$

$$\text{Also, } \vec{a} \cdot \vec{b} + \vec{b} \cdot \vec{c} + \vec{c} \cdot \vec{a} \geq \frac{-1}{2}(|\vec{a}|^2 + |\vec{b}|^2 + |\vec{c}|^2)$$

$$\geq -\frac{3}{2} \quad \dots(ii)$$

From Eqs. (i) and (ii), $|\vec{a} + \vec{b} + \vec{c}| = 0$

as $\vec{a} \cdot \vec{b} + \vec{b} \cdot \vec{c} + \vec{c} \cdot \vec{a}$ is minimum when $|\vec{a} + \vec{b} + \vec{c}| = 0$

$$\Rightarrow \vec{a} + \vec{b} + \vec{c} = 0$$

$$\therefore |2\mathbf{a} + 5\mathbf{b} + 5\mathbf{c}| = |2\mathbf{a} + 5(\mathbf{b} + \mathbf{c})| = |2\mathbf{a} - 5\mathbf{a}| = 3$$

Topic 2 Vector Product of Two Vectors

1. Given vectors, $\mathbf{a} = \hat{i} - 2\hat{j} + \hat{k}$ and $\mathbf{b} = \hat{i} - \hat{j} + \hat{k}$ and \mathbf{c} , such that $\mathbf{b} \times \mathbf{c} = \mathbf{b} \times \mathbf{a}$

$$\Rightarrow \mathbf{b} \times (\mathbf{c} - \mathbf{a}) = \mathbf{0} \Rightarrow \mathbf{b} \parallel \mathbf{c} - \mathbf{a}$$

$$\Rightarrow \mathbf{c} - \mathbf{a} = \lambda \mathbf{b}$$

$$\Rightarrow \mathbf{c} = \mathbf{a} + \lambda \mathbf{b}$$

$$\Rightarrow \mathbf{c} = (1 + \lambda)\hat{i} - (2 + \lambda)\hat{j} + (1 + \lambda)\hat{k}$$

$$\therefore \mathbf{c} \cdot \mathbf{a} = 0 \quad (\text{given})$$

$$\Rightarrow (1 + \lambda) + 2(2 + \lambda) + (1 + \lambda) = 0$$

$$\Rightarrow 4\lambda + 6 = 0$$

$$\Rightarrow \lambda = -\frac{3}{2}$$

$$\therefore \mathbf{c} = -\frac{1}{2}\hat{i} - \frac{1}{2}\hat{j} - \frac{1}{2}\hat{k}$$

$$\text{So } \mathbf{c} \cdot \mathbf{b} = -\frac{1}{2} + \frac{1}{2} - \frac{1}{2} = -\frac{1}{2}$$

Hence, option (c) is correct.

2. Given vectors are

$$\mathbf{a} = 3\hat{i} + 2\hat{j} + 2\hat{k} \text{ and } \mathbf{b} = \hat{i} + 2\hat{j} - 2\hat{k}$$

Now, vectors $\mathbf{a} + \mathbf{b} = 4\hat{i} + 4\hat{j}$ and $\mathbf{a} - \mathbf{b} = 2\hat{i} + 4\hat{k}$

\therefore A vector which is perpendicular to both the vectors $\mathbf{a} + \mathbf{b}$ and $\mathbf{a} - \mathbf{b}$ is

$$\begin{aligned} (\mathbf{a} + \mathbf{b}) \times (\mathbf{a} - \mathbf{b}) &= \begin{vmatrix} \hat{i} & \hat{j} & \hat{k} \\ 4 & 4 & 0 \\ 2 & 0 & 4 \end{vmatrix} \\ &= \hat{i}(16) - \hat{j}(16) + \hat{k}(-8) = 8(2\hat{i} - 2\hat{j} - \hat{k}) \end{aligned}$$

Then, the required vector along $(\mathbf{a} + \mathbf{b}) \times (\mathbf{a} - \mathbf{b})$ having magnitude 12 is

$$\pm 12 \times \frac{8(2\hat{i} - 2\hat{j} - \hat{k})}{8 \times \sqrt{4 + 4 + 1}} = \pm 4(2\hat{i} - 2\hat{j} - \hat{k})$$

3. Given three vectors are

$$\mathbf{a} = \alpha\hat{i} + \hat{j} + 3\hat{k}$$

$$\mathbf{b} = 2\hat{i} + \hat{j} - \alpha\hat{k}$$

$$\text{and } \mathbf{c} = \alpha\hat{i} - 2\hat{j} + 3\hat{k}$$

Clearly, $[\mathbf{a} \ \mathbf{b} \ \mathbf{c}] = \begin{vmatrix} \alpha & 1 & 3 \\ 2 & 1 & -\alpha \\ \alpha & -2 & 3 \end{vmatrix}$
 $= \alpha(3 - 2\alpha) - 1(6 + \alpha^2) + 3(-4 - \alpha)$
 $= -3\alpha^2 - 18 = -3(\alpha^2 + 6)$

\therefore There is no value of α for which $-3(\alpha^2 + 6)$ becomes zero, so = $\begin{vmatrix} \alpha & 1 & 3 \\ 2 & 1 & -\alpha \\ \alpha & -2 & 3 \end{vmatrix} [\mathbf{a} \ \mathbf{b} \ \mathbf{c}] \neq 0$

\Rightarrow vectors \mathbf{a} , \mathbf{b} and \mathbf{c} are not coplanar for any value $\alpha \in R$.

So, the set $S = \{\alpha : \mathbf{a}, \mathbf{b} \text{ and } \mathbf{c} \text{ are coplanar}\}$ is empty set.

4. Equation of given line is $\frac{x}{1} = \frac{y-1}{0} = \frac{z+1}{-1}$... (i)

Now, one of the point on line is $P(0, 1, -1)$ and the given point is $Q(\beta, 0, \beta)$.

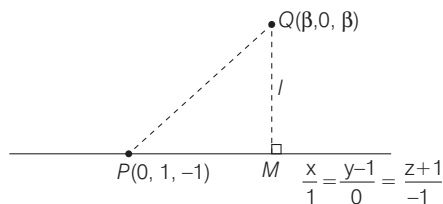

From the figure, the length of the perpendicular $QM = l = \sqrt{\frac{3}{2}}$ (given)

$\Rightarrow \frac{|\mathbf{PQ} \times \mathbf{PM}|}{|\mathbf{PM}|} = \sqrt{\frac{3}{2}}$... (ii)

$\therefore \mathbf{PQ} = \beta\hat{i} - \hat{j} + (\beta + 1)\hat{k}$
 and \mathbf{PM} = a vector along given line (i) $= \hat{i} - \hat{k}$

So, $\mathbf{PQ} \times \mathbf{PM} = \begin{vmatrix} \hat{i} & \hat{j} & \hat{k} \\ \beta & -1 & \beta + 1 \\ 1 & 0 & -1 \end{vmatrix}$
 $= \hat{i} - \hat{j}(-\beta - \beta - 1) + \hat{k} = \hat{i} + (2\beta + 1)\hat{j} + \hat{k}$

Now, $\frac{|\mathbf{PQ} \times \mathbf{PM}|}{|\mathbf{PM}|} = \frac{\sqrt{1 + (2\beta + 1)^2 + 1}}{\sqrt{2}}$... (iii)

From Eqs. (ii) and (iii), we get $\sqrt{\frac{1 + (2\beta + 1)^2 + 1}{2}} = \sqrt{\frac{3}{2}} \Rightarrow \frac{1 + (2\beta + 1)^2 + 1}{2} = \frac{3}{2}$
 [squaring both sides]

$\Rightarrow (2\beta + 1)^2 = 1 \Rightarrow 2\beta + 1 = \pm 1$
 $\Rightarrow 2\beta + 1 = 1 \text{ or } 2\beta + 1 = -1 \Rightarrow \beta = 0 \text{ or } \beta = -1$

5. Given vectors $\vec{\alpha} = 3\hat{i} + \hat{j}$ and $\vec{\beta} = 2\hat{i} - \hat{j} + 3\hat{k}$ and $\vec{\beta} = \vec{\beta}_1 - \vec{\beta}_2$ such that $\vec{\beta}_1$ is parallel to $\vec{\alpha}$ and $\vec{\beta}_2$ is perpendicular to α

So, $\vec{\beta}_1 = \lambda\alpha = \lambda(3\hat{i} + \hat{j})$
 Now, $\vec{\beta}_2 = \vec{\beta}_1 - \vec{\beta} = \lambda(3\hat{i} + \hat{j}) - (2\hat{i} - \hat{j} + 3\hat{k})$
 $= (3\lambda - 2)\hat{i} + (\lambda + 1)\hat{j} - 3\hat{k}$

$\therefore \vec{\beta}_2$ is perpendicular to α , so $\vec{\beta}_2 \cdot \alpha = 0$

[since if non-zero vectors \mathbf{a} and \mathbf{b} are perpendicular to each other, then $\mathbf{a} \cdot \mathbf{b} = 0$]

$\therefore (3\lambda - 2)(3) + (\lambda + 1)(1) = 0$
 $\Rightarrow 9\lambda - 6 + \lambda + 1 = 0$
 $\Rightarrow 10\lambda = 5 \Rightarrow \lambda = \frac{1}{2}$

So, $\vec{\beta}_1 = \frac{3}{2}\hat{i} + \frac{1}{2}\hat{j}$
 and $\vec{\beta}_2 = \left(\frac{3}{2} - 2\right)\hat{i} + \left(\frac{1}{2} + 1\right)\hat{j} - 3\hat{k} = -\frac{1}{2}\hat{i} + \frac{3}{2}\hat{j} - 3\hat{k}$

$\therefore \vec{\beta}_1 \times \vec{\beta}_2 = \begin{vmatrix} \hat{i} & \hat{j} & \hat{k} \\ \frac{3}{2} & \frac{1}{2} & 0 \\ -\frac{1}{2} & \frac{3}{2} & -3 \end{vmatrix} = \hat{i}\left(-\frac{3}{2} - 0\right) - \hat{j}\left(-\frac{9}{2} - 0\right) + \hat{k}\left(\frac{9}{4} + \frac{1}{4}\right)$
 $= -\frac{3}{2}\hat{i} + \frac{9}{2}\hat{j} + \frac{5}{2}\hat{k} = \frac{1}{2}(-3\hat{i} + 9\hat{j} + 5\hat{k})$

6. Given vectors are $\mathbf{a} = 3\hat{i} + 2\hat{j} + x\hat{k}$
 and $\mathbf{b} = \hat{i} - \hat{j} + \hat{k}$

$\therefore \mathbf{a} \times \mathbf{b} = \begin{vmatrix} \hat{i} & \hat{j} & \hat{k} \\ 3 & 2 & x \\ 1 & -1 & 1 \end{vmatrix} = \hat{i}(2 + x) - \hat{j}(3 - x) + \hat{k}(-3 - 2)$
 $= (x + 2)\hat{i} + (x - 3)\hat{j} - 5\hat{k}$

$\Rightarrow |\mathbf{a} \times \mathbf{b}| = \sqrt{(x + 2)^2 + (x - 3)^2 + 25}$
 $= \sqrt{2x^2 - 2x + 4 + 9 + 25}$
 $= \sqrt{2\left(x^2 - x + \frac{1}{4}\right) - \frac{1}{2} + 38} = \sqrt{2\left(x - \frac{1}{2}\right)^2 + \frac{75}{2}}$
 $= \sqrt{2\left(x^2 - x + \frac{1}{4}\right) - \frac{1}{2} + 38} = \sqrt{2\left(x - \frac{1}{2}\right)^2 + \frac{75}{2}}$

So, $|\mathbf{a} \times \mathbf{b}| \geq \sqrt{\frac{75}{2}}$ [at $x = \frac{1}{2}$, $|\mathbf{a} \times \mathbf{b}|$ is minimum]

$\Rightarrow r \geq 5\sqrt{\frac{3}{2}}$

7. The given vertices of tetrahedron $PQRO$ are $P(1, 2, 1)$, $Q(2, 1, 3)$, $R(-1, 1, 2)$ and $O(0, 0, 0)$.

The normal vector to the face OPQ
 $= \mathbf{OP} \times \mathbf{OQ} = (\hat{i} + 2\hat{j} + \hat{k}) \times (2\hat{i} + \hat{j} + 3\hat{k})$
 $= \begin{vmatrix} \hat{i} & \hat{j} & \hat{k} \\ 1 & 2 & 1 \\ 2 & 1 & 3 \end{vmatrix} = 5\hat{i} - \hat{j} - 3\hat{k}$

and the normal vector to the face PQR
 $= \mathbf{PQ} \times \mathbf{PR} = (\hat{i} - \hat{j} + 2\hat{k}) \times (-2\hat{i} - \hat{j} + \hat{k})$
 $= \begin{vmatrix} \hat{i} & \hat{j} & \hat{k} \\ 1 & -1 & 2 \\ -2 & -1 & 1 \end{vmatrix}$
 $= \hat{i}(-1 + 2) - \hat{j}(1 + 4) + \hat{k}(-1 - 2) = \hat{i} - 5\hat{j} - 3\hat{k}$

564 Vectors

Now, the angle between the faces OPQ and PQR is the angle between their normals

$$= \cos^{-1} \frac{|5 + 5 + 9|}{\sqrt{25 + 1 + 9} \sqrt{1 + 25 + 9}} = \cos^{-1} \left(\frac{19}{35} \right)$$

8. We have, $\mathbf{a} = 2\hat{\mathbf{i}} + \hat{\mathbf{j}} - 2\hat{\mathbf{k}}$

$$\Rightarrow |\mathbf{a}| = \sqrt{4 + 1 + 4} = 3$$

$$\text{and } \mathbf{b} = \hat{\mathbf{i}} + \hat{\mathbf{j}}$$

$$\Rightarrow |\mathbf{b}| = \sqrt{1 + 1} = \sqrt{2}$$

$$\text{Now, } |\mathbf{c} - \mathbf{a}| = 3$$

$$\Rightarrow |\mathbf{c} - \mathbf{a}|^2 = 9$$

$$\Rightarrow (\mathbf{c} - \mathbf{a}) \cdot (\mathbf{c} - \mathbf{a}) = 9$$

$$\Rightarrow |\mathbf{c}|^2 + |\mathbf{a}|^2 - 2\mathbf{c} \cdot \mathbf{a} = 9$$

...(i)

$$\text{Again, } |(\mathbf{a} \times \mathbf{b}) \times \mathbf{c}| = 3$$

$$\Rightarrow |\mathbf{a} \times \mathbf{b}| |\mathbf{c}| \sin 30^\circ = 3$$

$$\Rightarrow |\mathbf{c}| = \frac{6}{|\mathbf{a} \times \mathbf{b}|}$$

$$\text{But } \mathbf{a} \times \mathbf{b} = \begin{vmatrix} \hat{\mathbf{i}} & \hat{\mathbf{j}} & \hat{\mathbf{k}} \\ 2 & 1 & -2 \\ 1 & 1 & 0 \end{vmatrix} = 2\hat{\mathbf{i}} - 2\hat{\mathbf{j}} + \hat{\mathbf{k}}$$

$$\therefore |\mathbf{c}| = \frac{6}{\sqrt{4 + 4 + 1}} = 2 \quad \dots(\text{ii})$$

From Eqs. (i) and (ii), we get

$$(2)^2 + (3)^2 - 2\mathbf{c} \cdot \mathbf{a} = 9$$

$$\Rightarrow 4 + 9 - 2\mathbf{c} \cdot \mathbf{a} = 9$$

$$\Rightarrow \mathbf{c} \cdot \mathbf{a} = 2$$

9. Plan If $\vec{\mathbf{a}} \times \vec{\mathbf{b}} = \vec{\mathbf{a}} \times \vec{\mathbf{c}}$

$$\Rightarrow \vec{\mathbf{a}} \times \vec{\mathbf{b}} - \vec{\mathbf{a}} \times \vec{\mathbf{c}} = 0$$

$$\Rightarrow \vec{\mathbf{a}} \times (\vec{\mathbf{b}} - \vec{\mathbf{c}}) = 0$$

$$\text{i.e. } \vec{\mathbf{a}} \parallel (\vec{\mathbf{b}} - \vec{\mathbf{c}}) \text{ or } \vec{\mathbf{b}} - \vec{\mathbf{c}} = \lambda \vec{\mathbf{a}}$$

$$\text{Here, } \vec{\mathbf{a}} \times (2\hat{\mathbf{i}} + 3\hat{\mathbf{j}} + 4\hat{\mathbf{k}}) = (2\hat{\mathbf{i}} + 3\hat{\mathbf{j}} + 4\hat{\mathbf{k}}) \times \vec{\mathbf{b}}$$

$$\Rightarrow \vec{\mathbf{a}} \times (2\hat{\mathbf{i}} + 3\hat{\mathbf{j}} + 4\hat{\mathbf{k}}) - (2\hat{\mathbf{i}} + 3\hat{\mathbf{j}} + 4\hat{\mathbf{k}}) \times \vec{\mathbf{b}} = 0$$

$$\Rightarrow (\vec{\mathbf{a}} + \vec{\mathbf{b}}) \times (2\hat{\mathbf{i}} + 3\hat{\mathbf{j}} + 4\hat{\mathbf{k}}) = 0$$

$$\Rightarrow \vec{\mathbf{a}} + \vec{\mathbf{b}} = \lambda (2\hat{\mathbf{i}} + 3\hat{\mathbf{j}} + 4\hat{\mathbf{k}}) \quad \dots(\text{i})$$

$$\text{Since, } |\vec{\mathbf{a}} + \vec{\mathbf{b}}| = \sqrt{29}$$

$$\Rightarrow \pm \lambda \sqrt{4 + 9 + 16} = \sqrt{29}$$

$$\Rightarrow \lambda = \pm 1$$

$$\therefore \vec{\mathbf{a}} + \vec{\mathbf{b}} = \pm (2\hat{\mathbf{i}} + 3\hat{\mathbf{j}} + 4\hat{\mathbf{k}})$$

$$\text{Now, } (\vec{\mathbf{a}} + \vec{\mathbf{b}}) \cdot (-7\hat{\mathbf{i}} + 2\hat{\mathbf{j}} + 3\hat{\mathbf{k}}) = \pm (-14 + 6 + 12) = \pm 4$$

10. Since, $\vec{\mathbf{a}}, \vec{\mathbf{b}}, \vec{\mathbf{c}}$ are unit vectors and $\vec{\mathbf{a}} + \vec{\mathbf{b}} + \vec{\mathbf{c}} = \vec{\mathbf{0}}$, then $\vec{\mathbf{a}}, \vec{\mathbf{b}}, \vec{\mathbf{c}}$ represent an equilateral triangle.

$$\therefore \vec{\mathbf{a}} \times \vec{\mathbf{b}} = \vec{\mathbf{b}} \times \vec{\mathbf{c}} = \vec{\mathbf{c}} \times \vec{\mathbf{a}} \neq \vec{\mathbf{0}}.$$

11. By triangle law, $\vec{\mathbf{a}} + \vec{\mathbf{b}} + \vec{\mathbf{c}} = \vec{\mathbf{0}}$

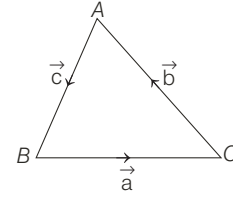

Taking cross product by $\vec{\mathbf{a}}, \vec{\mathbf{b}}, \vec{\mathbf{c}}$ respectively,

$$\vec{\mathbf{a}} \times (\vec{\mathbf{a}} + \vec{\mathbf{b}} + \vec{\mathbf{c}}) = \vec{\mathbf{a}} \times \vec{\mathbf{0}} = \vec{\mathbf{0}}$$

$$\Rightarrow \vec{\mathbf{a}} \times \vec{\mathbf{a}} + \vec{\mathbf{a}} \times \vec{\mathbf{b}} + \vec{\mathbf{a}} \times \vec{\mathbf{c}} = \vec{\mathbf{a}}$$

$$\Rightarrow \vec{\mathbf{a}} \times \vec{\mathbf{b}} = \vec{\mathbf{c}} \times \vec{\mathbf{a}} \quad [\because \vec{\mathbf{a}} \times \vec{\mathbf{a}} = \vec{\mathbf{0}}]$$

$$\text{Similarly, } \vec{\mathbf{a}} \times \vec{\mathbf{b}} = \vec{\mathbf{b}} \times \vec{\mathbf{a}}$$

$$\therefore \vec{\mathbf{a}} \times \vec{\mathbf{b}} = \vec{\mathbf{b}} \times \vec{\mathbf{c}} = \vec{\mathbf{c}} \times \vec{\mathbf{a}}$$

12. Given vectors $\mathbf{PQ} = a\hat{\mathbf{i}} + b\hat{\mathbf{j}}$ and $\mathbf{PS} = a\hat{\mathbf{i}} - b\hat{\mathbf{j}}$ are adjacent sides of a parallelogram $PQRS$, so area of parallelogram $PQRS = |\mathbf{PQ} \times \mathbf{PS}|$

$$= 2ab = 8$$

(given)

$$\therefore ab = 4 \quad \dots(\text{i})$$

According to the question,

$$|\mathbf{u}| = |\text{projection vector of } \mathbf{w} = \hat{\mathbf{i}} + \hat{\mathbf{j}} \text{ along } \mathbf{PQ}|$$

$$= \left| \frac{(\hat{\mathbf{i}} + \hat{\mathbf{j}}) \cdot (a\hat{\mathbf{i}} + b\hat{\mathbf{j}})}{\sqrt{a^2 + b^2}} \right| = \frac{|a + b|}{\sqrt{a^2 + b^2}}$$

and, similarly, $|\mathbf{v}| = |\text{projection vector of } \mathbf{w} = \hat{\mathbf{i}} + \hat{\mathbf{j}} \text{ along } \mathbf{PS}|$

$$= \frac{|(\hat{\mathbf{i}} + \hat{\mathbf{j}}) \cdot (a\hat{\mathbf{i}} + b\hat{\mathbf{j}})|}{\sqrt{a^2 + b^2}} = \frac{|a - b|}{\sqrt{a^2 + b^2}}$$

$$\therefore |\mathbf{u}| + |\mathbf{v}| = |\mathbf{w}|$$

$$\Rightarrow \frac{|a + b|}{\sqrt{a^2 + b^2}} + \frac{|a - b|}{\sqrt{a^2 + b^2}} = \sqrt{2}$$

$$\Rightarrow |a + b| + |a - b| = \sqrt{2} \sqrt{a^2 + b^2}$$

$$\text{If } a \geq b > 0, \text{ then } 2a = \sqrt{2} \sqrt{a^2 + b^2}$$

$$\Rightarrow 4a^2 = 2a^2 + 2b^2$$

$$\Rightarrow a^2 = b^2$$

$$\Rightarrow a = b$$

...(ii)

From Eqs. (i) and (ii), we get

$$a = 2 = b$$

$$\therefore a + b = 4$$

and the length of diagonal PR

$$= |a\hat{\mathbf{i}} + b\hat{\mathbf{j}} + a\hat{\mathbf{i}} - b\hat{\mathbf{j}}| = |2a\hat{\mathbf{i}}|$$

$$= 2a = 4$$

And, the angle bisector of vector \mathbf{PQ} and \mathbf{PS} is along the vector

$$\pm \frac{\lambda}{\sqrt{a^2 + b^2}} ((a\hat{\mathbf{i}} + b\hat{\mathbf{j}}) \pm (a\hat{\mathbf{i}} - b\hat{\mathbf{j}}))$$

13. Given, $|\mathbf{a}| = 12, |\mathbf{b}| = 4\sqrt{3}$

$$\begin{aligned} \mathbf{a} + \mathbf{b} + \mathbf{c} &= \mathbf{0} \\ \Rightarrow \mathbf{a} &= -(\mathbf{b} + \mathbf{c}) \end{aligned}$$

We have, $|\mathbf{a}|^2 = |\mathbf{b} + \mathbf{c}|^2$

$$\Rightarrow |\mathbf{a}|^2 = |\mathbf{b}|^2 + |\mathbf{c}|^2 + 2\mathbf{b} \cdot \mathbf{c}$$

$$\Rightarrow 144 = 48 + |\mathbf{c}|^2 + 48$$

$$\Rightarrow |\mathbf{c}|^2 = 48$$

$$\Rightarrow |\mathbf{c}| = 4\sqrt{3}$$

Also, $|\mathbf{c}|^2 = |\mathbf{a}|^2 + |\mathbf{b}|^2 + 2\mathbf{a} \cdot \mathbf{b}$

$$\Rightarrow 48 = 144 + 48 + 2\mathbf{a} \cdot \mathbf{b}$$

$$\Rightarrow \mathbf{a} \cdot \mathbf{b} = -72$$

\therefore Option (d) is correct.

Also, $\mathbf{a} \times \mathbf{b} = \mathbf{c} \times \mathbf{a}$

$$\Rightarrow \mathbf{a} \times \mathbf{b} + \mathbf{c} \times \mathbf{a} = 2\mathbf{a} \times \mathbf{b}$$

$$\begin{aligned} \Rightarrow |\mathbf{a} \times \mathbf{b} + \mathbf{c} \times \mathbf{a}| &= 2|\mathbf{a} \times \mathbf{b}| = 2\sqrt{|\mathbf{a}|^2|\mathbf{b}|^2 - (\mathbf{a} \cdot \mathbf{b})^2} \\ &= 2\sqrt{(144)(48) - (-72)^2} \\ &= 2(12)\sqrt{48 - 36} = 48\sqrt{3} \end{aligned}$$

\therefore Option (c) is correct.

Also, $\frac{|\mathbf{c}|^2}{2} - |\mathbf{a}| = 24 - 12 = 12$

\therefore Option (a) is correct.

and $\frac{|\mathbf{c}|^2}{2} + |\mathbf{a}| = 24 + 12 = 36$

\therefore Option (b) is not correct.

14. Let vector $\vec{\mathbf{OA}}$ be parallel to line of intersection of planes P_1 and P_2 through origin.

Normal to plane p_1 is

$$\vec{\mathbf{n}}_1 = [(2\hat{\mathbf{j}} + 3\hat{\mathbf{k}}) \times (4\hat{\mathbf{j}} - 3\hat{\mathbf{k}})] = -18\hat{\mathbf{i}}$$

Normal to plane p_2 is

$$\vec{\mathbf{n}}_2 = (\hat{\mathbf{j}} - \hat{\mathbf{k}}) \times (3\hat{\mathbf{i}} + 3\hat{\mathbf{j}}) = 3\hat{\mathbf{i}} - 3\hat{\mathbf{j}} - 3\hat{\mathbf{k}}$$

So, $\vec{\mathbf{OA}}$ is parallel to $\pm(\vec{\mathbf{n}}_1 \times \vec{\mathbf{n}}_2) = 54\hat{\mathbf{j}} - 54\hat{\mathbf{k}}$.

\therefore Angle between $54(\hat{\mathbf{j}} - \hat{\mathbf{k}})$ and $(2\hat{\mathbf{i}} + \hat{\mathbf{j}} - 2\hat{\mathbf{k}})$ is

$$\cos \theta = \pm \left(\frac{54 + 108}{3 \cdot 54 \cdot \sqrt{2}} \right) = \pm \frac{1}{\sqrt{2}}$$

$$\therefore \theta = \frac{\pi}{4}, \frac{3\pi}{4}$$

Hence, (b) and (d) are correct answers.

15. Let θ be the angle between $\vec{\mathbf{a}}$ and $\vec{\mathbf{b}}$. Since, $\vec{\mathbf{a}}$ and $\vec{\mathbf{a}}$ are non-collinear vectors, then $\theta \neq 0$ and $\theta \neq \pi$.

We have, $\vec{\mathbf{a}} \cdot \vec{\mathbf{b}} = |\vec{\mathbf{a}}||\vec{\mathbf{b}}| \cos \theta$

$$= \cos \theta \quad [\because |\vec{\mathbf{a}}|=1, |\vec{\mathbf{b}}|=1, \text{ given}]$$

Now, $\vec{\mathbf{u}} = \vec{\mathbf{a}} - (\vec{\mathbf{a}} \cdot \vec{\mathbf{b}})\vec{\mathbf{b}} \Rightarrow |\vec{\mathbf{u}}| = |\vec{\mathbf{a}} - (\vec{\mathbf{a}} \cdot \vec{\mathbf{b}})\vec{\mathbf{b}}|$

$$\Rightarrow |\vec{\mathbf{u}}|^2 = |\vec{\mathbf{a}} - (\vec{\mathbf{a}} \cdot \vec{\mathbf{b}})\vec{\mathbf{b}}|^2$$

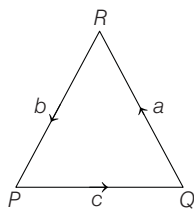

$$\Rightarrow |\vec{\mathbf{u}}|^2 = |\vec{\mathbf{a}} - \cos \theta \vec{\mathbf{b}}|^2$$

$$\Rightarrow |\vec{\mathbf{u}}|^2 = |\vec{\mathbf{a}}|^2 + \cos^2 \theta |\vec{\mathbf{b}}|^2 - 2 \cos \theta (\vec{\mathbf{a}} \cdot \vec{\mathbf{b}})$$

$$\Rightarrow |\vec{\mathbf{u}}|^2 = 1 + \cos^2 \theta - 2 \cos^2 \theta$$

$$\Rightarrow |\vec{\mathbf{u}}|^2 = 1 - \cos^2 \theta \Rightarrow |\vec{\mathbf{u}}|^2 = \sin^2 \theta$$

Also, $\vec{\mathbf{v}} = \vec{\mathbf{a}} \times \vec{\mathbf{b}}$ [given]

$$\Rightarrow |\vec{\mathbf{v}}|^2 = |\vec{\mathbf{a}} \times \vec{\mathbf{b}}|^2 \Rightarrow |\vec{\mathbf{v}}|^2 = |\vec{\mathbf{a}}|^2 |\vec{\mathbf{b}}|^2 \sin^2 \theta$$

$$\Rightarrow |\vec{\mathbf{v}}|^2 = \sin^2 \theta \quad \therefore |\vec{\mathbf{u}}|^2 = |\vec{\mathbf{v}}|^2$$

Now, $\vec{\mathbf{u}} \cdot \vec{\mathbf{a}} = [\vec{\mathbf{a}} - (\vec{\mathbf{a}} \cdot \vec{\mathbf{b}})\vec{\mathbf{b}}] \cdot \vec{\mathbf{a}} = \vec{\mathbf{a}} \cdot \vec{\mathbf{a}} - (\vec{\mathbf{a}} \cdot \vec{\mathbf{b}})(\vec{\mathbf{b}} \cdot \vec{\mathbf{a}})$

$$= (\vec{\mathbf{a}})^2 - \cos^2 \theta = 1 - \cos^2 \theta = \sin^2 \theta$$

$$\therefore |\vec{\mathbf{u}}| + |\vec{\mathbf{u}} \cdot \vec{\mathbf{a}}| = \sin \theta + \sin^2 \theta \neq |\vec{\mathbf{v}}|$$

$$\vec{\mathbf{u}} \cdot \vec{\mathbf{b}} = [\vec{\mathbf{a}} - (\vec{\mathbf{a}} \cdot \vec{\mathbf{b}})\vec{\mathbf{b}}] \cdot \vec{\mathbf{b}}$$

$$= \vec{\mathbf{a}} \cdot \vec{\mathbf{b}} - (\vec{\mathbf{a}} \cdot \vec{\mathbf{b}})(\vec{\mathbf{b}} \cdot \vec{\mathbf{b}}) = \vec{\mathbf{a}} \cdot \vec{\mathbf{b}} - \vec{\mathbf{a}} \cdot \vec{\mathbf{b}} |\vec{\mathbf{b}}|^2$$

$$= \vec{\mathbf{a}} \cdot \vec{\mathbf{b}} - \vec{\mathbf{a}} \cdot \vec{\mathbf{b}} = 0 \quad \dots(i)$$

$$\therefore |\vec{\mathbf{u}}| + |\vec{\mathbf{u}} \cdot \vec{\mathbf{b}}| = |\vec{\mathbf{u}}| + 0 = |\vec{\mathbf{u}}| = |\vec{\mathbf{v}}|$$

Also, $\vec{\mathbf{u}} \cdot (\vec{\mathbf{a}} + \vec{\mathbf{b}}) = \vec{\mathbf{u}} \cdot \vec{\mathbf{a}} + \vec{\mathbf{u}} \cdot \vec{\mathbf{b}} = \vec{\mathbf{u}} \cdot \vec{\mathbf{a}}$

$$\Rightarrow |\vec{\mathbf{u}}| + \vec{\mathbf{u}} \cdot (\vec{\mathbf{a}} + \vec{\mathbf{b}}) = |\vec{\mathbf{u}}| + \vec{\mathbf{u}} \cdot \vec{\mathbf{a}} \neq |\vec{\mathbf{v}}|$$

16. It is given that, in a ΔPQR

$\mathbf{PQ} = \mathbf{c}, \mathbf{QR} = \mathbf{a}$ and $\mathbf{RP} = \mathbf{b}$, so

$$\mathbf{a} + \mathbf{b} + \mathbf{c} = \mathbf{0}$$

$$\therefore |\mathbf{a}|^2 + \mathbf{a} \cdot \mathbf{b} + \mathbf{a} \cdot \mathbf{c} = 0 \quad \dots (i)$$

and $\mathbf{a} \cdot \mathbf{b} + |\mathbf{b}|^2 + \mathbf{c} \cdot \mathbf{b} = 0 \quad \dots (ii)$

and, also given that $|\mathbf{a}| = 3, |\mathbf{b}| = 4$

and $\frac{\mathbf{a} \cdot \mathbf{c} - \mathbf{a} \cdot \mathbf{b}}{\mathbf{c} \cdot \mathbf{a} - \mathbf{c} \cdot \mathbf{b}} = \frac{|\mathbf{a}|}{|\mathbf{a}| + |\mathbf{b}|} = \frac{3}{7}$

$$\Rightarrow 7[(\mathbf{a} \cdot \mathbf{c}) - (\mathbf{a} \cdot \mathbf{b})] = 3[(\mathbf{c} \cdot \mathbf{a}) - (\mathbf{c} \cdot \mathbf{b})]$$

from Eqs. (i) and (ii), on putting the values of $\mathbf{a} \cdot \mathbf{c}$ and $\mathbf{c} \cdot \mathbf{b}$, we get

$$\Rightarrow 7[-9 - (\mathbf{a} \cdot \mathbf{b}) - (\mathbf{a} \cdot \mathbf{b})] = 3[-9 - (\mathbf{a} \cdot \mathbf{b}) + 16 + (\mathbf{a} \cdot \mathbf{b})]$$

$$\Rightarrow 7[-9 - 2(\mathbf{a} \cdot \mathbf{b})] = 3 \times 7$$

$$\Rightarrow \mathbf{a} \cdot \mathbf{b} = -6$$

$$\therefore |\mathbf{a} \times \mathbf{b}|^2 = (|\mathbf{a}||\mathbf{b}|)^2 - (\mathbf{a} \cdot \mathbf{b})^2 = 144 - 36 = 108$$

17. Since, $\vec{\mathbf{PQ}}$ is not parallel to $\vec{\mathbf{TR}}$.

$\therefore \vec{\mathbf{TR}}$ is resultant of $\vec{\mathbf{RS}}$ and $\vec{\mathbf{ST}}$ vectors. $\Rightarrow \vec{\mathbf{PQ}} \times (\vec{\mathbf{RS}} + \vec{\mathbf{ST}}) \neq \vec{\mathbf{0}}$.

But for Statement II, we have

$$\vec{\mathbf{PQ}} \times \vec{\mathbf{RS}} = \vec{\mathbf{0}}$$

which is not possible as $\vec{\mathbf{PQ}}$ not parallel to $\vec{\mathbf{RS}}$.

Hence, Statement I is true and Statement II is false.

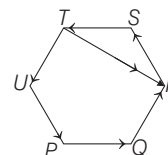

566 Vectors

18. $\cos(P + Q) + \cos(Q + R) + \cos(R + P)$
 $= -(\cos R + \cos P + \cos Q)$

Max. of $\cos P + \cos Q + \cos R = \frac{3}{2}$

Min. of $\cos(P + Q) + \cos(Q + R) + \cos(R + P)$ is $-\frac{3}{2}$

19. $\sin R = \sin(P + Q)$

20. Let \hat{i} be a unit vector in the direction of \vec{b} , \hat{j} in the direction of \vec{c} . Note that $\vec{c} = \hat{j}$

and $(\vec{b} \times \vec{c}) = |\vec{b}| |\vec{c}| \sin \alpha \hat{k} = \sin \alpha \hat{k}$

where, \hat{k} is a unit vector perpendicular to \vec{b} and \vec{c} .

$\Rightarrow |\vec{b} \times \vec{c}| = \sin \alpha \Rightarrow \hat{k} = \frac{\vec{b} \times \vec{c}}{|\vec{b} \times \vec{c}|}$

Let $\vec{a} = a_1 \hat{i} + a_2 \hat{j} + a_3 \hat{k}$

Now, $\vec{a} \cdot \vec{b} = \vec{a} \cdot \hat{i} = \hat{i} \cdot (a_1 \hat{i} + a_2 \hat{j} + a_3 \hat{k}) = a_1$

and $\vec{a} \cdot \vec{c} = \vec{a} \cdot \hat{j} = \hat{j} \cdot (a_1 \hat{i} + a_2 \hat{j} + a_3 \hat{k}) = a_2$

and $\vec{a} \cdot \frac{\vec{b} \times \vec{c}}{|\vec{b} \times \vec{c}|} = \vec{a} \cdot \hat{k} = a_3$

$\therefore (\vec{a} \cdot \vec{b}) \vec{b} + (\vec{a} \cdot \vec{c}) \vec{c} + \frac{\vec{a} \cdot (\vec{b} \times \vec{c})}{|\vec{b} \times \vec{c}|^2} (\vec{b} \times \vec{c})$
 $= a_1 \vec{b} + a_2 \vec{c} + a_3 \frac{(\vec{b} \times \vec{c})}{|\vec{b} \times \vec{c}|} = a_1 \hat{i} + a_2 \hat{j} + a_3 \hat{k} = \vec{a}$

21. A unit vector perpendicular to the plane determined by

P, Q, R $= \pm \frac{(\vec{PQ}) \times (\vec{PR})}{|\vec{PQ} \times \vec{PR}|}$

\therefore Unit vector $= \pm \frac{(\vec{PQ}) \times (\vec{PR})}{|\vec{PQ} \times \vec{PR}|}$

where, $\vec{PQ} = \hat{i} + \hat{j} - 3\hat{k}$

and $\vec{PR} = -\hat{i} + 3\hat{j} - \hat{k}$

$\therefore \vec{PQ} \times \vec{PR} = \begin{vmatrix} \hat{i} & \hat{j} & \hat{k} \\ 1 & 1 & -3 \\ -1 & 3 & -1 \end{vmatrix}$
 $= \hat{i}(-1 + 9) - \hat{j}(-1 - 3) + \hat{k}(3 + 1)$
 $= 8\hat{i} + 4\hat{j} + 4\hat{k}$

$\Rightarrow |\vec{PQ} \times \vec{PR}| = 4\sqrt{4 + 1 + 1} = 4\sqrt{6}$

$\therefore \frac{\vec{PQ} \times \vec{PR}}{|\vec{PQ} \times \vec{PR}|} = \pm \frac{4(2\hat{i} + \hat{j} + \hat{k})}{4\sqrt{6}} = \pm \frac{(2\hat{i} + \hat{j} + \hat{k})}{\sqrt{6}}$

22. Area of $\Delta ABC = \frac{1}{2} |\vec{AB} \times \vec{AC}|$

$\vec{AB} = \hat{i} + 2\hat{j} - 3\hat{k}$ and $\vec{AC} = 2\hat{i} + 2\hat{j} - 3\hat{k}$

$\therefore \vec{AB} \times \vec{AC} = \begin{vmatrix} \hat{i} & \hat{j} & \hat{k} \\ 1 & 2 & -3 \\ 2 & 0 & 0 \end{vmatrix} = 2(-3\hat{j} - 2\hat{k})$

\Rightarrow Area of triangle $= \frac{1}{2} |\vec{AB} \times \vec{AC}|$
 $= \frac{1}{2} \cdot 2 \cdot \sqrt{9 + 4} = \sqrt{13}$ sq units

23. Given, $\vec{A} \cdot \vec{B} = \vec{A} \cdot \vec{C} = 0$

$\Rightarrow \vec{A}$ is perpendicular to both \vec{B} and \vec{C} .

$\Rightarrow \vec{A} = \lambda (\vec{B} \times \vec{C})$

$|\vec{A}| = |\lambda| |\vec{B} \times \vec{C}|$, where $\vec{A}, \vec{B}, \vec{C}$ are unit vectors.

$\Rightarrow |\lambda| = \frac{1}{1 \cdot \sin 30^\circ} \Rightarrow |\lambda| = 2 \Rightarrow \lambda = \pm 2$

$\therefore \vec{A} = \pm 2 (\vec{B} \times \vec{C})$

Hence, given statement is true.

24. Given, $\vec{a} \times \vec{b} = \vec{c} \times \vec{d}$ and $\vec{a} \times \vec{c} = \vec{b} \times \vec{d}$

$\Rightarrow \vec{a} \times \vec{b} - \vec{a} \times \vec{c} = \vec{c} \times \vec{d} - \vec{b} \times \vec{d}$

$\Rightarrow \vec{a} \times (\vec{b} - \vec{c}) = (\vec{c} - \vec{b}) \times \vec{d}$

$\Rightarrow \vec{a} \times (\vec{b} - \vec{c}) - (\vec{c} - \vec{b}) \times \vec{d} = 0$

$\Rightarrow \vec{a} \times (\vec{b} - \vec{c}) - \vec{d} \times (\vec{b} - \vec{c}) = 0$

$\Rightarrow (\vec{a} - \vec{d}) \times (\vec{b} - \vec{c}) = 0 \Rightarrow (\vec{a} - \vec{d}) \parallel (\vec{b} - \vec{c})$

$\therefore (\vec{a} - \vec{d}) \cdot (\vec{b} - \vec{c}) \neq 0$

$\Rightarrow \vec{a} \cdot \vec{b} + \vec{d} \cdot \vec{c} \neq \vec{d} \cdot \vec{b} + \vec{a} \cdot \vec{c}$

25. (i) Since, $\vec{u} \cdot \vec{v} = |\vec{u}| |\vec{v}| \cos \theta$

and $\vec{u} \times \vec{v} = |\vec{u}| |\vec{v}| \sin \theta \hat{n}$

where, θ is the angle between \vec{u} and \vec{v} and \hat{n} is unit vector perpendicular to the plane of \vec{u} and \vec{v} .

Again, $|\vec{u} \cdot \vec{v}|^2 = |\vec{u}|^2 |\vec{v}|^2 \cos^2 \theta$ and

$|\vec{u} \times \vec{v}|^2 = |\vec{u}|^2 |\vec{v}|^2 \sin^2 \theta = |\vec{u}|^2 |\vec{v}|^2 \sin^2 \theta$

$\therefore |\vec{u} \cdot \vec{v}|^2 + |\vec{u} \times \vec{v}|^2 = |\vec{u}|^2 |\vec{v}|^2 (\cos^2 \theta + \sin^2 \theta)$

$= |\vec{u}|^2 |\vec{v}|^2 \dots(i)$

(ii) $|\vec{u} + \vec{v} + (\vec{u} \times \vec{v})|^2$

$= |\vec{u} + \vec{v}|^2 + |\vec{u} \times \vec{v}|^2 + 2(\vec{u} + \vec{v}) \cdot (\vec{u} \times \vec{v})$

$$\begin{aligned}
 &= |\vec{u}|^2 + |\vec{v}|^2 + 2\vec{u} \cdot \vec{v} + |\vec{u} \times \vec{v}|^2 + 0 \\
 & \quad [\because \vec{u} \times \vec{v} \text{ is perpendicular to the plane of } \vec{u} \text{ and } \vec{v}] \\
 \therefore & \quad |\vec{u} + \vec{v} + (\vec{u} \times \vec{v})|^2 + |1 - \vec{u} \cdot \vec{v}|^2 \\
 &= |\vec{u}|^2 + |\vec{v}|^2 + 2\vec{u} \cdot \vec{v} + |\vec{u} \times \vec{v}|^2 + 1 - 2\vec{u} \cdot \vec{v} + |\vec{u} \cdot \vec{v}|^2 \\
 &= |\vec{u}|^2 + |\vec{v}|^2 + 1 + |\vec{u}|^2 |\vec{v}|^2 \quad [\text{from Eq. (i)}] \\
 &= |\vec{u}|^2 (1 + |\vec{v}|^2) + (1 + |\vec{v}|^2) = (1 + |\vec{v}|^2) (1 + |\vec{u}|^2)
 \end{aligned}$$

26. Let the position vectors of points A, B, C, D be $\vec{a}, \vec{b}, \vec{c}$ and \vec{d} , respectively.

Then, $\vec{AB} = \vec{b} - \vec{a}, \vec{BC} = \vec{c} - \vec{b}, \vec{AD} = \vec{d} - \vec{a},$
 $\vec{BD} = \vec{d} - \vec{b}, \vec{CA} = \vec{a} - \vec{c}, \vec{CD} = \vec{d} - \vec{c}$

Now, $|\vec{AB} \times \vec{CD} + \vec{BC} \times \vec{AD} + \vec{CA} \times \vec{BD}|$
 $= |(\vec{b} - \vec{a}) \times (\vec{d} - \vec{c}) + (\vec{c} - \vec{b}) \times (\vec{d} - \vec{a}) + (\vec{a} - \vec{c}) \times (\vec{d} - \vec{b})|$
 $= |\vec{b} \times \vec{d} - \vec{a} \times \vec{d} - \vec{b} \times \vec{c} + \vec{a} \times \vec{c} + \vec{c} \times \vec{d} - \vec{c} \times \vec{a} - \vec{b} \times \vec{d}$
 $\quad + \vec{b} \times \vec{a} + \vec{a} \times \vec{d} - \vec{a} \times \vec{b} - \vec{c} \times \vec{d} + \vec{c} \times \vec{b}|$
 $= 2|\vec{a} \times \vec{b} + \vec{b} \times \vec{c} + \vec{c} \times \vec{a}| \quad \dots(i)$

Also, area of ΔABC
 $= \frac{1}{2} |\vec{AB} \times \vec{AC}| = \frac{1}{2} |(\vec{b} - \vec{a}) \times (\vec{c} - \vec{a})|$
 $= \frac{1}{2} |\vec{b} \times \vec{c} - \vec{b} \times \vec{a} - \vec{a} \times \vec{c} + \vec{a} \times \vec{a}|$
 $= \frac{1}{2} |\vec{a} \times \vec{a} + \vec{b} \times \vec{c} + \vec{c} \times \vec{a}| \quad \dots(ii)$

From Eqs. (i) and (ii),

$$\begin{aligned}
 &|\vec{AB} \times \vec{CD} + \vec{BC} \times \vec{AD} + \vec{CA} \times \vec{BD}| = 2(2 \text{ area of } \Delta ABC) \\
 &= 4(\text{area of } \Delta ABC)
 \end{aligned}$$

27. Since, $\vec{OA}_1, \vec{OA}_2, \dots, \vec{OA}_n$ are all vectors of same magnitude and angle between any two consecutive vectors is same i.e. $(2\pi/n)$.

$$\therefore \vec{OA}_1 \times \vec{OA}_2 = a^2 \cdot \sin \frac{2\pi}{n} \cdot \hat{p} \quad \dots(i)$$

where, \hat{p} is perpendicular to plane of polygon.

Now, $\sum_{i=1}^{n-1} (\vec{OA}_i \times \vec{OA}_{i+1}) = \sum_{i=1}^{n-1} a^2 \cdot \sin \frac{2\pi}{n} \cdot \hat{p}$
 $= (n-1) \cdot a^2 \cdot \sin \frac{2\pi}{n} \cdot \hat{p}$
 $= (n-1) [\vec{OA}_1 \times \vec{OA}_2]$
 $= (1-n) [\vec{OA}_2 \times \vec{OA}_1] = \text{RHS}$

Topic 3 Scalar Triple Product/Dot Product/Mixed Product

1. Given vectors, $\mu\hat{i} + \hat{j} + \hat{k}, \hat{i} + \mu\hat{j} + \hat{k}, \hat{i} + \hat{j} + \mu\hat{k}$ will be coplanar, if

$$\begin{vmatrix} \mu & 1 & 1 \\ 1 & \mu & 1 \\ 1 & 1 & \mu \end{vmatrix} = 0$$

$$\begin{aligned}
 \Rightarrow & \mu(\mu^2 - 1) - 1(\mu - 1) + 1(1 - \mu) = 0 \\
 \Rightarrow & (\mu - 1)[\mu(\mu + 1) - 1 - 1] = 0 \\
 \Rightarrow & (\mu - 1)[\mu^2 + \mu - 2] = 0 \\
 \Rightarrow & (\mu - 1)[(\mu + 2)(\mu - 1)] = 0 \\
 \Rightarrow & \mu = 1 \text{ or } -2
 \end{aligned}$$

So, sum of the distinct real values of $\mu = 1 - 2 = -1$.

2. We know that, if a, b, c are coplanar vectors, then $[a \ b \ c] = 0$

$$\therefore \begin{vmatrix} 1 & 2 & 4 \\ 1 & \lambda & 4 \\ 2 & 4 & \lambda^2 - 1 \end{vmatrix} = 0$$

$$\begin{aligned}
 \Rightarrow & 1\{\lambda(\lambda^2 - 1) - 16\} - 2\{(\lambda^2 - 1) - 8\} + 4(4 - 2\lambda) = 0 \\
 \Rightarrow & \lambda^3 - \lambda - 16 - 2\lambda^2 + 18 + 16 - 8\lambda = 0 \\
 \Rightarrow & \lambda^3 - 2\lambda^2 - 9\lambda + 18 = 0 \\
 \Rightarrow & \lambda^2(\lambda - 2) - 9(\lambda - 2) = 0 \\
 \Rightarrow & (\lambda - 2)(\lambda^2 - 9) = 0 \\
 \Rightarrow & (\lambda - 2)(\lambda + 3)(\lambda - 3) = 0 \\
 \therefore & \lambda = 2, 3 \text{ or } -3
 \end{aligned}$$

If $\lambda = 2$, then

$$\begin{aligned}
 a \times c &= \begin{vmatrix} \hat{i} & \hat{j} & \hat{k} \\ 1 & 2 & 4 \\ 2 & 4 & 3 \end{vmatrix} = \hat{i}(6 - 16) - \hat{j}(3 - 8) + \hat{k}(4 - 4) \\
 &= -10\hat{i} + 5\hat{j}
 \end{aligned}$$

$$\text{If } \lambda = \pm 3, \text{ then } a \times c = \begin{vmatrix} \hat{i} & \hat{j} & \hat{k} \\ 1 & 2 & 4 \\ 2 & 4 & 8 \end{vmatrix} = 0$$

(because last two rows are proportional).

3. Let angle between \vec{a} and \vec{b} be θ_1 , \vec{c} and \vec{d} be θ_2 and $\vec{a} \times \vec{b}$ and $\vec{b} \times \vec{d}$ be θ .

Since, $(\vec{a} \times \vec{b}) \cdot (\vec{c} \times \vec{d}) = 1$
 $\Rightarrow \sin \theta_1 \cdot \sin \theta_2 \cdot \cos \theta = 1$
 $\Rightarrow \theta_1 = 90^\circ, \theta_2 = 90^\circ, \theta = 0^\circ$
 $\Rightarrow \vec{a} \perp \vec{b}, \vec{c} \perp \vec{d}, (\vec{a} \times \vec{b}) \parallel (\vec{c} \times \vec{d})$

So, $\vec{a} \times \vec{b} = k(\vec{c} \times \vec{d})$ and $\vec{a} \times \vec{b} = k(\vec{c} \times \vec{d})$

$$\Rightarrow (\vec{a} \times \vec{b}) \cdot \vec{c} = k(\vec{c} \times \vec{d}) \cdot \vec{c}$$

and $(\vec{a} \times \vec{b}) \cdot \vec{d} = k(\vec{c} \times \vec{d}) \cdot \vec{d}$

$\Rightarrow [\vec{a} \ \vec{b} \ \vec{c}] = 0$ and $[\vec{a} \ \vec{b} \ \vec{d}] = 0$

$\Rightarrow \vec{a}, \vec{b}, \vec{c}$ and $\vec{a}, \vec{b}, \vec{d}$ are coplanar vectors, so options (a) and (b) are incorrect.

Let $\vec{b} \parallel \vec{d} \Rightarrow \vec{b} = \pm \vec{d}$

As $(\vec{a} \times \vec{b}) \cdot (\vec{c} \times \vec{d}) = 1 \Rightarrow (\vec{a} \times \vec{b}) \cdot (\vec{c} \times \vec{b}) = \pm 1$

$\Rightarrow [\vec{a} \ \vec{b} \ \vec{c} \ \vec{b}] = \pm 1 \Rightarrow [\vec{c} \ \vec{b} \ \vec{a} \ \vec{b}] = \pm 1$

$\Rightarrow \vec{c} \cdot [\vec{b} \times (\vec{a} \times \vec{b})] = \pm 1 \Rightarrow \vec{c} \cdot [\vec{a} - (\vec{b} \cdot \vec{a})\vec{b}] = \pm 1$

$\Rightarrow \vec{c} \cdot \vec{a} = \pm 1$ $[\vec{c} \ \vec{a} \ \vec{b}] = 0$

which is a contradiction, so option (c) is correct.

Let option (d) is correct.

$\Rightarrow \vec{d} = \pm \vec{a}$

and $\vec{c} = \pm \vec{b}$

As $(\vec{a} \times \vec{b}) \cdot (\vec{c} \times \vec{d}) = 1$

$\Rightarrow (\vec{a} \times \vec{b}) \cdot (\vec{b} \times \vec{a}) = \pm 1$

which is a contradiction, so option (d) is incorrect. Alternatively, options (c) and (d) may be observed from the given figure.

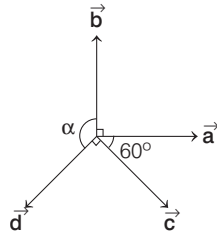

4. The volume of the parallelepiped with coterminal edges as $\hat{a}, \hat{b}, \hat{c}$ is given by $[\hat{a} \ \hat{b} \ \hat{c}] = \hat{a} \cdot (\hat{b} \times \hat{c})$

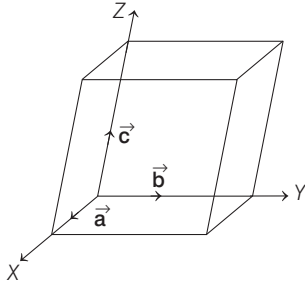

Now, $[\hat{a} \ \hat{b} \ \hat{c}]^2 = \begin{vmatrix} \hat{a} \cdot \hat{a} & \hat{a} \cdot \hat{b} & \hat{a} \cdot \hat{c} \\ \hat{b} \cdot \hat{a} & \hat{b} \cdot \hat{b} & \hat{b} \cdot \hat{c} \\ \hat{c} \cdot \hat{a} & \hat{c} \cdot \hat{b} & \hat{c} \cdot \hat{c} \end{vmatrix} = \begin{vmatrix} 1 & 1/2 & 1/2 \\ 1/2 & 1 & 1/2 \\ 1/2 & 1/2 & 1 \end{vmatrix}$

$\Rightarrow [\hat{a} \ \hat{b} \ \hat{c}]^2 = 1 \left(1 - \frac{1}{4} \right) - \frac{1}{2} \left(\frac{1}{2} - \frac{1}{4} \right) + \frac{1}{2} \left(\frac{1}{4} - \frac{1}{2} \right) = \frac{1}{2}$

Thus, the required volume of the parallelepiped $= \frac{1}{\sqrt{2}}$ cu unit

5. Since, given vectors are coplanar

$\therefore \begin{vmatrix} -\lambda^2 & 1 & 1 \\ 1 & -\lambda^2 & 1 \\ 1 & 1 & -\lambda^2 \end{vmatrix} = 0$

$\Rightarrow \lambda^6 - 3\lambda^2 - 2 = 0 \Rightarrow (1 + \lambda^2)^2(\lambda^2 - 2) = 0 \Rightarrow \lambda = \pm \sqrt{2}$

6. We know that, volume of parallelopiped whose edges are $\vec{a}, \vec{b}, \vec{c} = [\vec{a} \ \vec{b} \ \vec{c}]$.

$\therefore [\vec{a} \ \vec{b} \ \vec{c}] = \begin{vmatrix} 1 & a & 1 \\ 0 & 1 & a \\ a & 0 & 1 \end{vmatrix} = 1 + a^3 - a$

Let $f(a) = a^3 - a + 1$

$\Rightarrow f'(a) = 3a^2 - 1 \Rightarrow f''(a) = 6a$

For maximum or minimum, put $f'(a) = 0$

$\Rightarrow a = \pm \frac{1}{\sqrt{3}}$, which shows $f(a)$ is minimum at $a = \frac{1}{\sqrt{3}}$

and maximum at $a = -\frac{1}{\sqrt{3}}$.

7. Given, $\vec{V} = 2\hat{i} + \hat{j} - \hat{k}$ and $\vec{W} = \hat{i} + 3\hat{k}$

$[\vec{U} \ \vec{V} \ \vec{W}] = \vec{U} \cdot [(2\hat{i} + \hat{j} - \hat{k}) \times (\hat{i} + 3\hat{k})]$

$= \vec{U} \cdot (3\hat{i} - 7\hat{j} - \hat{k}) = |\vec{U}| |3\hat{i} - 7\hat{j} - \hat{k}| \cos \theta$

which is maximum, if angle between \vec{U} and $3\hat{i} - 7\hat{j} - \hat{k}$ is 0 and maximum value

$= |3\hat{i} - 7\hat{j} - \hat{k}| = \sqrt{59}$

8. $[\vec{a} \ \vec{b} \ \vec{c}] = \begin{vmatrix} 1 & 0 & -1 \\ x & 1 & 1-x \\ y & x & 1+x-y \end{vmatrix}$

Applying $C_3 \rightarrow C_1 + C_3$,

$\begin{vmatrix} 1 & 0 & 0 \\ x & 1 & 1 \\ y & x & 1+x \end{vmatrix} = 1$

Therefore, it neither depends on x nor y .

9. If $\vec{a}, \vec{b}, \vec{c}$ are coplanar vectors, then $2\vec{a} - \vec{b}, 2\vec{b} - \vec{c}$ and $2\vec{c} - \vec{a}$ are also coplanar vectors.

i.e. $[2\vec{a} - \vec{b} \ \ 2\vec{b} - \vec{c} \ \ 2\vec{c} - \vec{a}] = 0$

10. $[\vec{u} \ \vec{v} \ \vec{w}] = |\vec{v} \ \vec{w} \ \vec{u}| = [\vec{w} \ \vec{u} \ \vec{v}] = -[\vec{v} \ \vec{u} \ \vec{w}]$

Therefore, (c) is the answer.

11. Since, $\vec{a}, \vec{b}, \vec{c}$ are linearly dependent vectors.

$\Rightarrow [\vec{a} \ \vec{b} \ \vec{c}] = 0$

$\Rightarrow \begin{vmatrix} 1 & 1 & 1 \\ 4 & 3 & 4 \\ 1 & \alpha & \beta \end{vmatrix} = 0$

Applying $C_2 \rightarrow C_2 - C_1, C_3 \rightarrow C_3 - C_1$,

$\begin{vmatrix} 1 & 0 & 0 \\ 4 & -1 & 0 \\ 1 & \alpha - 1 & \beta - 1 \end{vmatrix} = 0 \Rightarrow -(\beta - 1) = 0 \Rightarrow \beta = 1$

Also, $|\vec{c}| = \sqrt{3}$ [given]

$\Rightarrow 1 + \alpha^2 + \beta^2 = 3$ [given, $c = \hat{i} + \alpha\hat{j} + \beta\hat{k}$]

$\Rightarrow 1 + \alpha^2 + 1 = 3 \Rightarrow \alpha^2 = 1 \Rightarrow \alpha = \pm 1$

12. $(\vec{a} + \vec{b} + \vec{c}) \cdot [(\vec{a} + \vec{b}) \times (\vec{a} + \vec{c})]$
 $= (\vec{a} + \vec{b} + \vec{c}) \cdot [\vec{a} \times \vec{a} + \vec{a} \times \vec{c} + \vec{b} \times \vec{a} + \vec{b} \times \vec{c}]$
 $= \{\vec{a} \cdot (\vec{a} \times \vec{c}) + \vec{a} \cdot (\vec{b} \times \vec{a}) + \vec{a} \cdot (\vec{b} \times \vec{c})\} + \{\vec{b} \cdot (\vec{a} \times \vec{c})$
 $+ \vec{b} \cdot (\vec{b} \times \vec{a}) + \vec{b} \cdot (\vec{b} \times \vec{c})\} + \{\vec{c} \cdot (\vec{a} \times \vec{c}) + \vec{c} \cdot (\vec{b} \times \vec{a}) + \vec{c} \cdot (\vec{b} \times \vec{c})\}$
 $= [\vec{a} \vec{b} \vec{c}] + [\vec{b} \vec{a} \vec{c}] + [\vec{c} \vec{b} \vec{a}] = [\vec{a} \vec{b} \vec{c}]$

13. Let $\vec{d} = x\hat{i} + y\hat{j} + z\hat{k}$
 where, $x^2 + y^2 + z^2 = 1$... (i)
 [$\therefore \vec{d}$ being unit vector]

Since, $\vec{a} \cdot \vec{d} = 0$
 $\Rightarrow x - y = 0 \Rightarrow x = y$... (ii)

Also, $[\vec{b} \vec{c} \vec{d}] = 0$
 $\Rightarrow \begin{vmatrix} 0 & 1 & -1 \\ -1 & 0 & 1 \\ x & y & z \end{vmatrix} = 0 \Rightarrow x + y + z = 0$
 $\Rightarrow 2x + z = 0$ [from Eq. (ii)] ... (iii)

From Eqs. (i), (ii) and (iii),
 $x^2 + x^2 + 4x^2 = 1 \Rightarrow x = \pm \frac{1}{\sqrt{6}}$
 $\therefore \vec{d} = \pm \frac{1}{\sqrt{6}} (\hat{i} + \hat{j} - 2\hat{k})$

14. Since, three vectors are coplanar.

$$\begin{vmatrix} a & a & c \\ 1 & 0 & 1 \\ c & c & b \end{vmatrix} = 0$$

Applying $C_1 \rightarrow C_1 - C_2$, $\begin{vmatrix} 0 & a & c \\ 1 & 0 & 1 \\ 0 & c & b \end{vmatrix} = 0$
 $\Rightarrow -1(ab - c^2) = 0 \Rightarrow ab = c^2$

15. Since, $(\vec{a} \times \vec{b}) = |\vec{a}||\vec{b}|\sin \frac{\pi}{6} \hat{n}$

$$(\vec{a} \times \vec{b}) \cdot \vec{c} = \frac{1}{2} |\vec{a}||\vec{b}| \cdot \hat{n} \cdot \vec{c}$$

$$[\vec{a} \vec{b} \vec{c}] = \frac{1}{2} |\vec{a}||\vec{b}| \cdot \cos 0^\circ$$

$\therefore \hat{n}$ is perpendicular to both \vec{a}, \vec{b} and \vec{c} is also a unit vector perpendicular to both \vec{a} and \vec{b} .

$$\therefore \begin{vmatrix} a_1 & a_2 & a_3 \\ b_1 & b_2 & b_3 \\ c_1 & c_2 & c_3 \end{vmatrix}^2 = [\vec{a} \vec{b} \vec{c}]^2 = \frac{1}{4} \cdot |\vec{a}|^2 |\vec{b}|^2$$

$$= \frac{1}{4} (a_1^2 + a_2^2 + a_3^2) (b_1^2 + b_2^2 + b_3^2)$$

16. The volume of parallelopiped $= [\vec{a} \vec{b} \vec{c}] = \begin{vmatrix} 2 & -3 & 0 \\ 1 & 1 & -1 \\ 3 & 0 & -1 \end{vmatrix}$
 $= 2(-1) + 3(-1 + 3) = -2 + 6 = 4$

17. Given, $|(\vec{a} \times \vec{b}) \cdot \vec{c}| = |\vec{a}||\vec{b}||\vec{c}|$
 $\Rightarrow ||\vec{a}||\vec{b}|\sin \theta \hat{n} \cdot \vec{c}| = |\vec{a}||\vec{b}||\vec{c}|$
 $\Rightarrow |\vec{a}||\vec{b}||\vec{c}|\sin \theta \cdot \cos \alpha = |\vec{a}||\vec{b}||\vec{c}|$
 $\Rightarrow |\sin \theta| \cdot |\cos \alpha| = 1 \Rightarrow \theta = \frac{\pi}{2}$ and $\alpha = 0$

$\therefore \vec{a} \perp \vec{b}$ and $\vec{c} \parallel \hat{n}$
 i.e. $\vec{a} \perp \vec{b}$ and \vec{c} perpendicular to both \vec{a} and \vec{b} .

18. $\vec{A} \cdot \{(\vec{B} + \vec{C}) \times (\vec{A} + \vec{B} + \vec{C})\}$
 [\therefore it is a scalar triple product of three vectors of the form $\vec{A}, \vec{B} + \vec{C}, \vec{A} + \vec{B} + \vec{C}$]

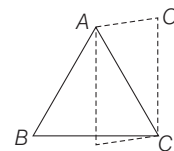

$$= \vec{A} \cdot (\vec{B} \times \vec{A} + \vec{B} \times \vec{B} + \vec{B} \times \vec{C} + \vec{C} \times \vec{A} + \vec{C} \times \vec{B} + \vec{C} \times \vec{C})$$

$$= \vec{A} \cdot (\vec{B} \times \vec{A}) + \vec{A} \cdot (\vec{B} \times \vec{C}) + \vec{A} \cdot (\vec{C} \times \vec{B})$$

$$= [\vec{A} \vec{B} \vec{A}] - [\vec{A} \vec{B} \vec{C}] = 0$$

19. Let θ be the angle between \hat{u} and \vec{v} .

$$\therefore |\vec{u} \times \vec{v}| = 1 \Rightarrow |\vec{u}||\vec{v}|\sin \theta = 1$$

$$\therefore |\vec{v}|\sin \theta = 1$$
 [$\therefore |\vec{u}| = 1$] ... (i)

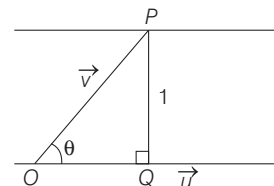

Clearly, there may be infinite vectors $\vec{OP} = \vec{v}$, such that P is always 1 unit distance from \hat{u} .

\therefore Option (b) is correct.

Again, let ϕ be the angle between \vec{w} and $\vec{u} \times \vec{v}$.

$$\therefore \vec{w} \cdot (\vec{u} \times \vec{v}) = 1 \Rightarrow |\vec{w}||\vec{u} \times \vec{v}|\cos \phi = 1$$

$$\Rightarrow \cos \phi = 1 \Rightarrow \phi = 0$$

Thus, $\vec{w} = \vec{u} \times \vec{v}$

Now, if \hat{u} lies in XY -plane, then

$$\vec{u} \times \vec{v} = \begin{vmatrix} \hat{i} & \hat{j} & \hat{k} \\ u_1 & u_2 & 0 \\ v_1 & v_2 & v_3 \end{vmatrix} \text{ or } \vec{u} = u_1 \hat{i} + u_2 \hat{j}$$

$$\therefore \vec{w} = (u_2 v_3) \hat{i} - (u_1 v_3) \hat{j} + (u_1 v_2 - v_1 u_2) \hat{k}$$

$$= \frac{1}{\sqrt{6}} (\hat{i} + \hat{j} + 2\hat{k})$$

$$\therefore u_2 v_3 = \frac{1}{\sqrt{6}}, u_1 v_3 = \frac{-1}{\sqrt{6}}$$

$$\Rightarrow \frac{u_2 v_3}{u_1 v_3} = -1 \text{ or } |u_1| = |u_2|$$

\therefore Option (c) is correct.

570 Vectors

Now, if \hat{u} lies in XZ -plane, then $\mathbf{u} = u_1\hat{i} + u_3\hat{k}$

$$\therefore \mathbf{u} \times \mathbf{v} = \begin{vmatrix} \hat{i} & \hat{j} & \hat{k} \\ u_1 & 0 & u_3 \\ v_1 & v_2 & v_3 \end{vmatrix}$$

$$\Rightarrow \mathbf{w} = (-v_2u_3)\hat{i} - (u_1v_3 - u_3v_1)\hat{j} + (u_1v_2)\hat{k}$$

$$\Rightarrow \hat{k} = \frac{1}{\sqrt{6}}(\hat{i} + \hat{j} + 2\hat{k})$$

$$\Rightarrow -v_2u_3 = \frac{1}{\sqrt{6}} \text{ and } u_1v_2 = \frac{2}{\sqrt{6}}$$

$$\therefore |u_2| = 2|u_3|$$

\therefore Option (d) is wrong.

20. (a) $\vec{u} \cdot (\vec{v} \times \vec{w})$ is a meaningful operation.

Therefore, (a) is the answer.

- (b) $\vec{u} \cdot (\vec{v} \cdot \vec{w})$ is not meaningful, since $\vec{v} \cdot \vec{w}$ is a scalar quantity and for dot product both quantities should be vector.

Therefore, (b) is not the answer.

- (c) $(\vec{u} \cdot \vec{v})\vec{w}$ is meaningful, since it is a simple multiplication of vector and scalar quantity. Therefore, (c) is the answer.

- (d) $\vec{u} \times (\vec{v} \cdot \vec{w})$ is not meaningful, since $\vec{v} \cdot \vec{w}$ is a scalar quantity and for cross product, both quantities should be vector.

Therefore, (d) is not the answer.

21. Since, $q =$ area of parallelogram with \vec{OA} and \vec{OC} as

$$\text{adjacent sides} = |\vec{OA} \times \vec{OC}| = |\vec{a} \times \vec{b}|$$

and $p =$ area of quadrilateral $OABC$

$$= \frac{1}{2}|\vec{OA} \times \vec{OB}| + \frac{1}{2}|\vec{OB} \times \vec{OC}|$$

$$= \frac{1}{2}|\vec{a} \times (10\vec{a} + 2\vec{b})| + \frac{1}{2}|(10\vec{a} + 2\vec{b}) \times \vec{b}|$$

$$= |\vec{a} \times \vec{b}| + 5|\vec{a} \times \vec{b}| = 6|\vec{a} \times \vec{b}|$$

$$\therefore p = 6q \Rightarrow k = 6$$

22. Since, vectors are coplanar.

$$\therefore \begin{vmatrix} a & 1 & 1 \\ 1 & b & 1 \\ 1 & 1 & c \end{vmatrix} = 0$$

Applying $R_2 \rightarrow R_2 - R_1$, $R_3 \rightarrow R_3 - R_1$,

$$\Rightarrow \begin{vmatrix} a & 1 & 1 \\ 1-a & b-1 & 0 \\ 1-a & 0 & c-1 \end{vmatrix} = 0$$

$$\Rightarrow \begin{vmatrix} a/(1-a) & 1/(1-b) & 1/(1-c) \\ 1 & -1 & 0 \\ 1 & 0 & -1 \end{vmatrix} = 0$$

$$\Rightarrow \frac{a}{1-a}(1) - \frac{1}{1-b}(-1) + \frac{1}{1-c}(1) = 0$$

$$\Rightarrow \frac{a}{1-a} + \frac{1}{1-b} + \frac{1}{1-c} = 0$$

$$\Rightarrow -1 + \frac{1}{1-a} + \frac{1}{1-b} + \frac{1}{1-c} = 0$$

$$\Rightarrow \frac{1}{1-a} + \frac{1}{1-b} + \frac{1}{1-c} = 1$$

$$23. \frac{\vec{A} \cdot (\vec{B} \times \vec{C})}{(\vec{C} \times \vec{A}) \cdot \vec{B}} + \frac{\vec{B} \cdot (\vec{A} \times \vec{C})}{\vec{C} \cdot (\vec{A} \times \vec{B})}$$

$$= \frac{[\vec{A} \vec{B} \vec{C}]}{[\vec{C} \vec{A} \vec{B}]} + \frac{[\vec{B} \vec{A} \vec{C}]}{[\vec{C} \vec{A} \vec{B}]} = \frac{[\vec{A} \vec{B} \vec{C}] - [\vec{A} \vec{B} \vec{C}]}{[\vec{C} \vec{A} \vec{B}]} = 0$$

$$24. \text{ Since, } \begin{vmatrix} a & a^2 & 1+a^3 \\ b & b^2 & 1+b^3 \\ c & c^2 & 1+c^3 \end{vmatrix} = 0$$

$$\Rightarrow \begin{vmatrix} a & a^2 & 1 \\ b & b^2 & 1 \\ c & c^2 & 1 \end{vmatrix} + \begin{vmatrix} a & a^2 & a^3 \\ b & b^2 & b^3 \\ c & c^2 & c^3 \end{vmatrix} = 0$$

$$\Rightarrow (1+abc) \begin{vmatrix} 1 & a & a^2 \\ 1 & b & b^2 \\ 1 & c & c^2 \end{vmatrix} = 0$$

$$\Rightarrow \text{Either } (1+abc) = 0 \text{ or } \begin{vmatrix} 1 & a & a^2 \\ 1 & b & b^2 \\ 1 & c & c^2 \end{vmatrix} = 0$$

But $(1, a, a^2), (1, b, b^2), (1, c, c^2)$ are non-coplanar.

$$\Rightarrow \begin{vmatrix} 1 & a & a^2 \\ 1 & b & b^2 \\ 1 & c & c^2 \end{vmatrix} \neq 0$$

$$\therefore abc = -1$$

$$25. (\vec{a} - \vec{b}) \cdot \{(\vec{b} - \vec{c}) \times (\vec{c} - \vec{a})\} = (\vec{a} - \vec{b}) \cdot (\vec{b} \times \vec{c} - \vec{b} \times \vec{a} + \vec{c} \times \vec{a})$$

$$= \vec{a} \cdot (\vec{b} \times \vec{c}) - \vec{b} \cdot (\vec{c} \times \vec{a}) = [\vec{a} \vec{b} \vec{c}] + [\vec{a} \vec{b} \vec{c}]$$

$$= 2[\vec{a} \vec{b} \vec{c}] = 2\vec{a} \cdot (\vec{b} \times \vec{c})$$

Hence, it is a true statement.

26. Since, $\vec{X} \cdot \vec{A} = \vec{X} \cdot \vec{B} = \vec{X} \cdot \vec{C} = 0$

$\Rightarrow \vec{X}$ is perpendicular to $\vec{A}, \vec{B}, \vec{C}$, therefore $[\vec{A} \vec{B} \vec{C}] = 0$

Hence, given statement is true.

$$27. \left. \begin{aligned} \vec{x} &= \frac{\vec{u} + \vec{v}}{|\vec{u} + \vec{v}|} = \frac{1}{2} \sec \frac{\alpha}{2} (\vec{u} + \vec{v}) \\ \vec{y} &= \frac{\vec{w} + \vec{v}}{|\vec{v} + \vec{w}|} = \frac{1}{2} \sec \frac{\beta}{2} (\vec{v} + \vec{w}) \\ \vec{z} &= \frac{\vec{w} + \vec{u}}{|\vec{w} + \vec{u}|} = \frac{1}{2} \sec \frac{\gamma}{2} (\vec{w} + \vec{u}) \end{aligned} \right\} \dots(i)$$

Since, $[\vec{x} \times \vec{y} \vec{y} \times \vec{z} \vec{z} \times \vec{x}] = [\vec{x} \vec{y} \vec{z}]^2$ [from Eq. (i)]

$$= \frac{1}{64} \sec^2 \frac{\alpha}{2} \cdot \sec^2 \frac{\beta}{2} \cdot \sec^2 \frac{\gamma}{2} [\vec{u} + \vec{v} \vec{v} + \vec{w} \vec{w} + \vec{u}]^2 \dots(ii)$$

and $[\vec{u} + \vec{v} \vec{v} + \vec{w} \vec{w} + \vec{u}] = 2[\vec{u} \vec{v} \vec{w}]$... (iii)

$$\therefore [\vec{x} \times \vec{y} \vec{y} \times \vec{z} \vec{z} \times \vec{x}]$$

$$= \frac{1}{64} \sec^2 \frac{\alpha}{2} \cdot \sec^2 \frac{\beta}{2} \cdot \sec^2 \frac{\gamma}{2} \cdot 4 [\vec{u} \vec{v} \vec{w}]^2$$

$$= \frac{1}{16} \cdot [\vec{u} \vec{v} \vec{w}]^2 \sec^2 \frac{\alpha}{2} \cdot \sec^2 \frac{\beta}{2} \cdot \sec^2 \frac{\gamma}{2}$$

28. $V = |\vec{a} \cdot (\vec{b} \times \vec{c})| \leq \sqrt{a_1^2 + a_2^2 + a_3^2} \sqrt{b_1^2 + b_2^2 + b_3^2} \sqrt{c_1^2 + c_2^2 + c_3^2}$... (i)

Now, $L = \frac{(a_1 + a_2 + a_3) + (b_1 + b_2 + b_3) + (c_1 + c_2 + c_3)}{3} \geq [(a_1 + a_2 + a_3)(b_1 + b_2 + b_3)(c_1 + c_2 + c_3)]^{1/3}$ [using AM \geq GM]

$$\Rightarrow L^3 \geq [(a_1 + a_2 + a_3)(b_1 + b_2 + b_3)(c_1 + c_2 + c_3)] \dots(ii)$$

Now, $(a_1 + a_2 + a_3)^2 = a_1^2 + a_2^2 + a_3^2 + 2a_1a_2 + 2a_1a_3 + 2a_2a_3 \geq a_1^2 + a_2^2 + a_3^2$
 $\Rightarrow (a_1 + a_2 + a_3) \geq \sqrt{a_1^2 + a_2^2 + a_3^2}$

Similarly, $(b_1 + b_2 + b_3) \geq \sqrt{b_1^2 + b_2^2 + b_3^2}$

and $(c_1 + c_2 + c_3) \geq \sqrt{c_1^2 + c_2^2 + c_3^2}$
 $\therefore L^3 \geq [(a_1^2 + a_2^2 + a_3^2)(b_1^2 + b_2^2 + b_3^2)(c_1^2 + c_2^2 + c_3^2)]^{1/2}$
 $\Rightarrow L^3 \geq V$ [from Eq. (i)]

29. Given equation is $\vec{w} + (\vec{w} \times \vec{u}) = \vec{v}$... (i)

Taking cross product with \vec{u} , we get

$$\vec{u} \times [\vec{w} + (\vec{w} \times \vec{u})] = \vec{u} \times \vec{v}$$

$$\Rightarrow \vec{u} \times \vec{w} + \vec{u} \times (\vec{w} \times \vec{u}) = \vec{u} \times \vec{v}$$

$$\Rightarrow \vec{u} \times \vec{w} + (\vec{u} \cdot \vec{u}) \vec{w} - (\vec{u} \cdot \vec{w}) \vec{u} = \vec{u} \times \vec{v}$$

$$\Rightarrow \vec{u} \times \vec{w} + \vec{w} - (\vec{u} \cdot \vec{w}) \vec{u} = \vec{u} \times \vec{v} \dots(ii)$$

Now, taking dot product of Eq. (i) with \vec{u} , we get

$$\vec{u} \cdot \vec{w} + \vec{u} \cdot (\vec{w} \times \vec{u}) = \vec{u} \cdot \vec{v}$$

$$\Rightarrow \vec{u} \cdot \vec{w} = \vec{u} \cdot \vec{v} \quad [\because \vec{u} \cdot (\vec{w} \times \vec{u}) = 0] \dots(iii)$$

Now, taking dot product of Eq. (i) with \vec{u} , we get

$$\vec{v} \cdot \vec{w} + \vec{v} \cdot (\vec{w} \times \vec{u}) = \vec{v} \cdot \vec{v}$$

$$\Rightarrow \vec{v} \cdot \vec{w} + [\vec{v} \vec{w} \vec{u}] = 1 \Rightarrow \vec{v} \cdot \vec{w} + [\vec{v} \vec{w} \vec{u}] - 1 = 0$$

$$\Rightarrow -(\vec{u} \times \vec{v}) \cdot \vec{w} - \vec{v} \cdot \vec{w} + 1 = 0$$

$$\Rightarrow 1 - \vec{v} \cdot \vec{w} = (\vec{u} \times \vec{v}) \cdot \vec{w} \dots(iv)$$

Taking dot product of Eq. (ii) with \vec{w} , we get

$$(\vec{u} \times \vec{v}) \cdot \vec{w} + \vec{w} \cdot \vec{w} - (\vec{u} \cdot \vec{w})(\vec{u} \cdot \vec{w}) = (\vec{u} \times \vec{v}) \cdot \vec{w} \dots(v)$$

$$\Rightarrow 0 + |\vec{w}|^2 - (\vec{u} \cdot \vec{w})^2 = (\vec{u} \times \vec{v}) \cdot \vec{w}$$

$$\Rightarrow (\vec{u} \times \vec{v}) \cdot \vec{w} = |\vec{w}|^2 - (\vec{u} \cdot \vec{w})^2$$

Taking dot product of Eq. (i) with \vec{w} , we get

$$\vec{w} \cdot \vec{w} + (\vec{w} \times \vec{u}) \cdot \vec{w} = \vec{v} \cdot \vec{w}$$

$$\Rightarrow |\vec{w}|^2 + 0 = \vec{v} \cdot \vec{w} \dots(vi)$$

$$\Rightarrow |\vec{w}|^2 = 1 - (\vec{u} \times \vec{v}) \cdot \vec{w} \quad [\text{from Eq. (iv)}]$$

Again, from Eq. (v), we get

$$(\vec{u} \times \vec{v}) \cdot \vec{w} + |\vec{w}|^2 - (\vec{u} \cdot \vec{w})^2 = 1 - (\vec{u} \times \vec{v}) \cdot \vec{w} - (\vec{u} \cdot \vec{w})^2$$

$$\Rightarrow 2(\vec{u} \times \vec{v}) \cdot \vec{w} = 1 - (\vec{u} \cdot \vec{w})^2 \quad [\text{from Eq. (iii)}]$$

$$\Rightarrow \left| (\vec{u} \times \vec{v}) \cdot \vec{w} \right| = \frac{1}{2} \left| 1 - (\vec{u} \cdot \vec{w})^2 \right| \leq \frac{1}{2} \quad [\because (\vec{u} \cdot \vec{w})^2 \geq 0]$$

The equality holds if and only if $\vec{u} \cdot \vec{w} = 0$ or iff \vec{u} is perpendicular to \vec{w} .

30. Here, $\vec{AB} = -\hat{i} + 5\hat{j} - 3\hat{k}$

$$\vec{AC} = -4\hat{i} + 3\hat{j} + 3\hat{k} \text{ and } \vec{AD} = \hat{i} + 7\hat{j} + (\lambda + 1)\hat{k}$$

We know that, A, B, C, D lie in a plane if $\vec{AB}, \vec{AC}, \vec{AD}$ are coplanar i.e.

$$[\vec{AB} \vec{AC} \vec{AD}] = 0 \Rightarrow \begin{vmatrix} -1 & 5 & -3 \\ -4 & 3 & 3 \\ 1 & 7 & \lambda + 1 \end{vmatrix} = 0$$

$$\Rightarrow -1(3\lambda + 3 - 21) - 5(-4\lambda - 4 - 3) - 3(-28 - 3) = 0$$

$$\Rightarrow -17\lambda + 146 = 0$$

$$\therefore \lambda = \frac{146}{17}$$

31. Given vectors $\mathbf{a} = 2\hat{i} + \hat{j} - \hat{k}$

and $\mathbf{b} = \hat{i} + 2\hat{j} + \hat{k}$

So, $\mathbf{a} + \mathbf{b} = 3\hat{i} + 3\hat{j}$

$$\Rightarrow |\mathbf{a} + \mathbf{b}| = 3\sqrt{2}$$

Since, it is given that projection of $\mathbf{c} = \alpha\mathbf{a} + \beta\mathbf{b}$ on the vector $(\mathbf{a} + \mathbf{b})$ is $3\sqrt{2}$, then

$$\frac{(\mathbf{a} + \mathbf{b}) \cdot \mathbf{c}}{|\mathbf{a} + \mathbf{b}|} = 3\sqrt{2}$$

$$\Rightarrow (\mathbf{a} + \mathbf{b}) \cdot (\alpha\mathbf{a} + \beta\mathbf{b}) = 18$$

$$\Rightarrow \alpha(\mathbf{a} \cdot \mathbf{a}) + \beta(\mathbf{a} \cdot \mathbf{b}) + \alpha(\mathbf{b} \cdot \mathbf{a}) + \beta(\mathbf{b} \cdot \mathbf{b}) = 18$$

$$\Rightarrow 6\alpha + 3\beta + 3\alpha + 6\beta = 18$$

$$\Rightarrow 9\alpha + 9\beta = 18$$

$$\Rightarrow (\alpha + \beta) = 2 \dots(i)$$

572 Vectors

Now, for minimum value of $(\mathbf{c} - (\mathbf{a} \times \mathbf{b})) \cdot \mathbf{c}$

$$\begin{aligned}
 &= (\alpha \mathbf{a} + \beta \mathbf{b} - (\mathbf{a} \times \mathbf{b})) \cdot (\alpha \mathbf{a} + \beta \mathbf{b}) \\
 &= \alpha^2 (\mathbf{a} \cdot \mathbf{a}) + \alpha\beta(\mathbf{a} \cdot \mathbf{b}) + \alpha\beta(\mathbf{a} \cdot \mathbf{b}) + \beta^2(\mathbf{b} \cdot \mathbf{b}) \\
 &\quad [\because (\mathbf{a} \times \mathbf{b}) \cdot \mathbf{a} = 0 = (\mathbf{a} \times \mathbf{b}) \cdot \mathbf{b}] \\
 &= 6\alpha^2 + 6\alpha\beta + 6\beta^2 = 6(\alpha^2 + \beta^2 + \alpha\beta) \\
 &= 6[(\alpha + \beta)^2 - \alpha\beta] = 6[4 - \alpha\beta] = 6[4 - \alpha(2 - \alpha)] \\
 &= 6[4 - 2\alpha + \alpha^2]
 \end{aligned}$$

The minimum value of $6(4 - 2\alpha + \alpha^2) = 6(3) = 18$

[As minimum value of $ax^2 + bx + c = -\frac{D}{4a}$, if $a > 0$]

Topic 4 Vector Triple Product

1. We have, $(\mathbf{a} \times \mathbf{c}) + \mathbf{b} = 0$

$$\Rightarrow \mathbf{a} \times (\mathbf{a} \times \mathbf{c}) + \mathbf{a} \times \mathbf{b} = 0$$

(taking cross product with \mathbf{a} on both sides)

$$\Rightarrow (\mathbf{a} \cdot \mathbf{c})\mathbf{a} - (\mathbf{a} \cdot \mathbf{a})\mathbf{c} + \begin{vmatrix} \hat{i} & \hat{j} & \hat{k} \\ 1 & -1 & 0 \\ 1 & 1 & 1 \end{vmatrix} = 0$$

$$[\because \mathbf{a} \times (\mathbf{b} \times \mathbf{c}) = (\mathbf{a} \cdot \mathbf{c})\mathbf{b} - (\mathbf{a} \cdot \mathbf{b})\mathbf{c}]$$

$$\Rightarrow 4(\hat{i} - \hat{j}) - 2\mathbf{c} + (-\hat{i} - \hat{j} + 2\hat{k}) = 0$$

$$[\because \mathbf{a} \cdot \mathbf{a} = (\hat{i} - \hat{j}) \cdot (\hat{i} - \hat{j}) = 1 + 1 = 2 \text{ and } \mathbf{a} \cdot \mathbf{c} = 4]$$

$$\Rightarrow 2\mathbf{c} = 4\hat{i} - 4\hat{j} - \hat{i} - \hat{j} + 2\hat{k}$$

$$\Rightarrow \mathbf{c} = \frac{3\hat{i} - 5\hat{j} + 2\hat{k}}{2} \Rightarrow |\mathbf{c}|^2 = \frac{9 + 25 + 4}{4} = \frac{19}{2}$$

2. Given, $\mathbf{a} \times (\mathbf{b} \times \mathbf{c}) = \frac{1}{2}\mathbf{b} \Rightarrow (\mathbf{a} \cdot \mathbf{c})\mathbf{b} - (\mathbf{a} \cdot \mathbf{b})\mathbf{c} = \frac{1}{2}\mathbf{b}$

$$[\because \mathbf{a} \times (\mathbf{b} \times \mathbf{c}) = (\mathbf{a} \cdot \mathbf{c})\mathbf{b} - (\mathbf{a} \cdot \mathbf{b})\mathbf{c}]$$

On comparing both sides, we get

$$\mathbf{a} \cdot \mathbf{c} = \frac{1}{2} \quad \dots(\text{i})$$

$$\text{and } \mathbf{a} \cdot \mathbf{b} = 0 \quad \dots(\text{ii})$$

$\because \mathbf{a}, \mathbf{b}$ and \mathbf{c} are unit vectors, and angle between \mathbf{a} and \mathbf{b} is α and angle between \mathbf{a} and \mathbf{c} is β , so

$$|\mathbf{a}| |\mathbf{c}| \cos \beta = \frac{1}{2} \quad [\text{from Eq. (i)}]$$

$$\Rightarrow \cos \beta = \frac{1}{2} \quad [\because |\mathbf{a}| = 1 = |\mathbf{c}|]$$

$$\Rightarrow \beta = \frac{\pi}{3} \quad \dots(\text{iii}) \quad \left[\because \cos \frac{\pi}{3} = \frac{1}{2} \right]$$

$$\text{and } |\mathbf{a}| |\mathbf{b}| \cos \alpha = 0 \quad [\text{from Eq. (ii)}]$$

$$\Rightarrow \alpha = \frac{\pi}{2} \quad \dots(\text{iv})$$

From Eqs. (iii) and (iv), we get

$$|\alpha - \beta| = \frac{\pi}{2} - \frac{\pi}{3} = \frac{\pi}{6} = 30^\circ$$

3. Given, $|\hat{\mathbf{a}}| = |\hat{\mathbf{b}}| = |\hat{\mathbf{c}}| = 1$

$$\text{and } \hat{\mathbf{a}} \times (\hat{\mathbf{b}} \times \hat{\mathbf{c}}) = \frac{\sqrt{3}}{2} (\hat{\mathbf{b}} + \hat{\mathbf{c}})$$

$$\text{Now, consider } \hat{\mathbf{a}} \times (\hat{\mathbf{b}} \times \hat{\mathbf{c}}) = \frac{\sqrt{3}}{2} (\hat{\mathbf{b}} + \hat{\mathbf{c}})$$

$$\Rightarrow (\hat{\mathbf{a}} \cdot \hat{\mathbf{c}}) \hat{\mathbf{b}} - (\hat{\mathbf{a}} \cdot \hat{\mathbf{b}}) \hat{\mathbf{c}} = \frac{\sqrt{3}}{2} \hat{\mathbf{b}} + \frac{\sqrt{3}}{2} \hat{\mathbf{c}}$$

On comparing, we get

$$\hat{\mathbf{a}} \cdot \hat{\mathbf{b}} = -\frac{\sqrt{3}}{2} \Rightarrow |\hat{\mathbf{a}}| |\hat{\mathbf{b}}| \cos \theta = -\frac{\sqrt{3}}{2}$$

$$\Rightarrow \cos \theta = -\frac{\sqrt{3}}{2} \quad [\because |\hat{\mathbf{a}}| = |\hat{\mathbf{b}}| = 1]$$

$$\Rightarrow \cos \theta = \cos \left(\pi - \frac{\pi}{6} \right) \Rightarrow \theta = \frac{5\pi}{6}$$

4. Given, $(\vec{\mathbf{a}} \times \vec{\mathbf{b}}) \times \vec{\mathbf{c}} = \frac{1}{3} |\vec{\mathbf{b}}| |\vec{\mathbf{c}}| \vec{\mathbf{a}}$

$$\Rightarrow -\vec{\mathbf{c}} \times (\vec{\mathbf{a}} \times \vec{\mathbf{b}}) = \frac{1}{3} |\vec{\mathbf{b}}| |\vec{\mathbf{c}}| \vec{\mathbf{a}}$$

$$\Rightarrow -(\vec{\mathbf{c}} \cdot \vec{\mathbf{b}}) \vec{\mathbf{a}} + (\vec{\mathbf{c}} \cdot \vec{\mathbf{a}}) \vec{\mathbf{b}} = \frac{1}{3} |\vec{\mathbf{b}}| |\vec{\mathbf{c}}| \vec{\mathbf{a}}$$

$$\Rightarrow \left[\frac{1}{3} |\vec{\mathbf{b}}| |\vec{\mathbf{c}}| + (\vec{\mathbf{c}} \cdot \vec{\mathbf{b}}) \right] \vec{\mathbf{a}} = (\vec{\mathbf{c}} \cdot \vec{\mathbf{a}}) \vec{\mathbf{b}}$$

Since, \mathbf{a} and \mathbf{b} are not collinear.

$$\therefore \vec{\mathbf{c}} \cdot \vec{\mathbf{b}} + \frac{1}{3} |\vec{\mathbf{b}}| |\vec{\mathbf{c}}| = 0 \text{ and } \vec{\mathbf{c}} \cdot \vec{\mathbf{a}} = 0$$

$$\Rightarrow |\vec{\mathbf{b}}| |\vec{\mathbf{c}}| \cos \theta + \frac{1}{3} |\vec{\mathbf{b}}| |\vec{\mathbf{c}}| = 0 \Rightarrow |\vec{\mathbf{b}}| |\vec{\mathbf{c}}| \left(\cos \theta + \frac{1}{3} \right) = 0$$

$$\Rightarrow \cos \theta + \frac{1}{3} = 0 \quad [\because |\vec{\mathbf{b}}| \neq 0, |\vec{\mathbf{c}}| \neq 0]$$

$$\Rightarrow \cos \theta = -\frac{1}{3} \Rightarrow \sin \theta = \frac{\sqrt{8}}{3} = \frac{2\sqrt{2}}{3}$$

5. As we know that, a vector coplanar to $\vec{\mathbf{a}}, \vec{\mathbf{b}}$ and orthogonal to $\vec{\mathbf{c}}$ is $\lambda \{(\vec{\mathbf{a}} \times \vec{\mathbf{b}}) \times \vec{\mathbf{c}}\}$.

\therefore A vector coplanar to $(2\hat{\mathbf{i}} + \hat{\mathbf{j}} + \hat{\mathbf{k}})$, $(\hat{\mathbf{i}} - \hat{\mathbf{j}} + \hat{\mathbf{k}})$ and orthogonal to $3\hat{\mathbf{i}} + 2\hat{\mathbf{j}} + 6\hat{\mathbf{k}}$

$$\begin{aligned}
 &= \lambda \{[(2\hat{\mathbf{i}} + \hat{\mathbf{j}} + \hat{\mathbf{k}}) \times (\hat{\mathbf{i}} - \hat{\mathbf{j}} + \hat{\mathbf{k}})] \times (3\hat{\mathbf{i}} + 2\hat{\mathbf{j}} + 6\hat{\mathbf{k}})\} \\
 &= \lambda [(2\hat{\mathbf{i}} - \hat{\mathbf{j}} - 3\hat{\mathbf{k}}) \times (3\hat{\mathbf{i}} + 2\hat{\mathbf{j}} + 6\hat{\mathbf{k}})] = \lambda (21\hat{\mathbf{j}} - 7\hat{\mathbf{k}})
 \end{aligned}$$

$$\therefore \text{Unit vector} = + \frac{(21\hat{\mathbf{j}} - 7\hat{\mathbf{k}})}{\sqrt{(21)^2 + (7)^2}} = + \frac{(3\hat{\mathbf{j}} - \hat{\mathbf{k}})}{\sqrt{10}}$$

6. We know that, $\vec{\mathbf{a}} \times (\vec{\mathbf{a}} \times \vec{\mathbf{b}}) = (\vec{\mathbf{a}} \cdot \vec{\mathbf{b}}) \vec{\mathbf{a}} - (\vec{\mathbf{a}} \cdot \vec{\mathbf{a}}) \vec{\mathbf{b}}$

$$\therefore (\hat{\mathbf{i}} + \hat{\mathbf{j}} + \hat{\mathbf{k}}) \times (\hat{\mathbf{j}} - \hat{\mathbf{k}}) = (\hat{\mathbf{i}} + \hat{\mathbf{j}} + \hat{\mathbf{k}}) - (\sqrt{3})^2 \vec{\mathbf{b}}$$

$$\Rightarrow -2\hat{\mathbf{i}} + \hat{\mathbf{j}} + \hat{\mathbf{k}} = \hat{\mathbf{i}} + \hat{\mathbf{j}} + \hat{\mathbf{k}} - 3\vec{\mathbf{b}} \Rightarrow 3\vec{\mathbf{b}} = + 3\hat{\mathbf{i}}$$

$$\therefore \vec{\mathbf{b}} = \hat{\mathbf{i}}$$

7. If θ is the angle between P_1 and P_2 , then normal to the planes are

$$\begin{aligned}
 N_1 &= \vec{\mathbf{a}} \times \vec{\mathbf{b}}, \\
 N_2 &= \vec{\mathbf{c}} \times \vec{\mathbf{d}}
 \end{aligned}$$

$$\therefore N_1 \times N_2 = 0$$

$$\text{Then, } |N_1| \times |N_2| \sin \theta = 0$$

$$\Rightarrow \sin \theta = 0 \Rightarrow \theta = 0$$

8. **NOTE** In this question, vector \vec{c} is not given, therefore, we cannot apply the formulae of $\vec{a} \times \vec{b} \times \vec{c}$ (vector triple product).

Now, $|\vec{a} \times \vec{b}| \times |\vec{c}| = |\vec{a} \times \vec{b}| |\vec{c}| \sin 30^\circ \dots(i)$

Again, $|\vec{a} \times \vec{b}| = \begin{vmatrix} \hat{i} & \hat{j} & \hat{k} \\ 2 & 1 & -2 \\ 1 & 1 & 0 \end{vmatrix} = 2\hat{i} - 2\hat{j} + \hat{k}$

$\Rightarrow |\vec{a} \times \vec{b}| = \sqrt{2^2 + (-2)^2 + 1} = \sqrt{4 + 4 + 1} = \sqrt{9} = 3$

Since, $|\vec{c} - \vec{a}| = 2\sqrt{2}$ [given]

$\Rightarrow |\vec{c} - \vec{a}|^2 = 8$

$\Rightarrow (\vec{c} - \vec{a}) \cdot (\vec{c} - \vec{a}) = 8$

$\Rightarrow \vec{c} \cdot \vec{c} - \vec{c} \cdot \vec{a} - \vec{a} \cdot \vec{c} + \vec{a} \cdot \vec{a} = 8$

$\Rightarrow |\vec{c}|^2 + |\vec{a}|^2 - 2\vec{a} \cdot \vec{c} = 8$

$\Rightarrow |\vec{c}|^2 + 9 - 2|\vec{c}| = 8$

$\Rightarrow |\vec{c}|^2 - 2|\vec{c}| + 1 = 0$

$\Rightarrow (|\vec{c}| - 1)^2 = 0 \Rightarrow |\vec{c}| = 1$

From Eq. (i), $|\vec{a} \times \vec{b}| \times |\vec{c}| = (3)(1) \cdot \left(\frac{1}{2}\right) = \frac{3}{2}$

9. Since, $\vec{a} \times (\vec{b} \times \vec{c}) = \frac{\vec{b} + \vec{c}}{\sqrt{2}}$

$\Rightarrow (\vec{a} \cdot \vec{c})\vec{b} - (\vec{a} \cdot \vec{b})\vec{c} = \frac{1}{\sqrt{2}}\vec{b} + \frac{1}{\sqrt{2}}\vec{c}$

On equating the coefficient of \vec{c} , we get

$\vec{a} \cdot \vec{b} = -\frac{1}{\sqrt{2}}$

$\Rightarrow |\vec{a}| |\vec{b}| \cos \theta = -\frac{1}{\sqrt{2}}$

$\therefore \cos \theta = -\frac{1}{\sqrt{2}}$

$\Rightarrow \theta = \frac{3\pi}{4}$

10. Let $\vec{a} = \hat{i} + \hat{j} + 2\hat{k}$, $\vec{b} = \hat{i} + 2\hat{j} + \hat{k}$

and $\vec{c} = \hat{i} + \hat{j} + \hat{k}$

\therefore A vector coplanar to \vec{a} and \vec{b} , and perpendicular to \vec{c}

$= \lambda (\vec{a} \times \vec{b}) \times \vec{c} = \lambda \{(\vec{a} \cdot \vec{c})\vec{b} - (\vec{b} \cdot \vec{c})\vec{a}\}$
 $= \lambda \{(1 + 1 + 4)(\hat{i} + 2\hat{j} + \hat{k}) - (1 + 2 + 1)(\hat{i} + \hat{j} + 2\hat{k})\}$
 $= \lambda \{6\hat{i} + 12\hat{j} + 6\hat{k} - 6\hat{i} - 6\hat{j} - 12\hat{k}\}$
 $= \lambda \{6\hat{j} - 6\hat{k}\} = 6\lambda \{\hat{j} - \hat{k}\}$

For $\lambda = \frac{1}{6} \Rightarrow$ Option (a) is correct.

and for $\lambda = -\frac{1}{6} \Rightarrow$ Option (d) is correct.

11. There are three vectors given \mathbf{a} , \mathbf{b} and \mathbf{c} , such that $|\mathbf{a}| = \sqrt{3}$, $|\mathbf{b}| = 5$ and $\mathbf{b} \cdot \mathbf{c} = 10$

So, $|\mathbf{b}| |\mathbf{c}| \cos \frac{\pi}{3} = 10$

(\because it is given angle between \mathbf{b} and \mathbf{c} is $\frac{\pi}{3}$)

$\Rightarrow 5|\mathbf{c}| \left(\frac{1}{2}\right) = 10 \Rightarrow |\mathbf{c}| = 4$

Now, as \mathbf{a} is perpendicular to the vector $\mathbf{b} \times \mathbf{c}$, so

$|\mathbf{a} \times (\mathbf{b} \times \mathbf{c})| = |\mathbf{a}| |\mathbf{b} \times \mathbf{c}| \sin \frac{\pi}{2}$
 $= |\mathbf{a}| |\mathbf{b} \times \mathbf{c}| = |\mathbf{a}| |\mathbf{b}| |\mathbf{c}| \sin \frac{\pi}{3}$
 $= (\sqrt{3})(5)(4) \frac{\sqrt{3}}{2} = 30$

Hence answer is 30.

12. From the given information, it is clear that

$\vec{a} = \frac{\hat{i} - 2\hat{j}}{\sqrt{5}} \Rightarrow |\vec{a}| = 1, |\vec{b}| = 1, \vec{a} \cdot \vec{b} = 0$

Now, $(2\vec{a} + \vec{b}) \cdot [(\vec{a} \times \vec{b}) \times (\vec{a} - 2\vec{b})]$

$= (2\vec{a} + \vec{b}) \cdot [a^2\vec{b} - (\vec{a} \cdot \vec{b})\vec{a} + 2b^2\vec{a} - 2(\vec{b} \cdot \vec{a})\vec{b}]$
 $= [2\vec{a} + \vec{b}] \cdot [\vec{b} + 2\vec{a}] = 4\vec{a}^2 + \vec{b}^2$
 $= 4 \cdot 1 + 1 = 5$ [as $\mathbf{a} \cdot \mathbf{b} = 0$]

13. Here, $P(1, 0, 0)$, $Q(0, 1, 0)$, $R(0, 0, 1)$, $T(1, 1, 1)$ and $S\left(\frac{1}{2}, \frac{1}{2}, \frac{1}{2}\right)$.

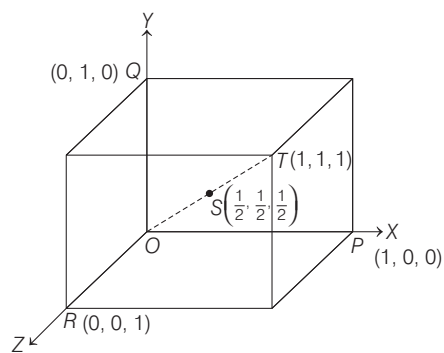

Now, $\vec{p} = \vec{SP} = \vec{OP} - \vec{OS}$
 $= \left(\frac{1}{2}\hat{i} - \frac{1}{2}\hat{j} - \frac{1}{2}\hat{k}\right) = \frac{1}{2}(\hat{i} - \hat{j} - \hat{k})$
 $\vec{q} = \vec{SQ} = \frac{1}{2}(-\hat{i} + \hat{j} - \hat{k})$
 $\vec{r} = \vec{SR} = \frac{1}{2}(-\hat{i} - \hat{j} + \hat{k})$
 and $\vec{t} = \vec{ST} = \frac{1}{2}(\hat{i} + \hat{j} + \hat{k})$

574 Vectors

$$\vec{p} \times \vec{q} = \frac{1}{4} \begin{vmatrix} \hat{i} & \hat{j} & \hat{k} \\ 1 & -1 & -1 \\ -1 & 1 & -1 \end{vmatrix} = \frac{1}{4} (2\hat{i} + 2\hat{j})$$

$$\text{and } \vec{r} \times \vec{t} = \frac{1}{4} \begin{vmatrix} \hat{i} & \hat{j} & \hat{k} \\ -1 & -1 & 1 \\ 1 & 1 & 1 \end{vmatrix} = \frac{1}{4} (-2\hat{i} + 2\hat{j})$$

$$\text{Now, } (\vec{p} \times \vec{q}) \times (\vec{r} \times \vec{t}) = \frac{1}{16} \begin{vmatrix} \hat{i} & \hat{j} & \hat{k} \\ 2 & 2 & 0 \\ -2 & 2 & 0 \end{vmatrix} = \frac{1}{16} (8\hat{k}) = \frac{1}{2} \hat{k}$$

$$\therefore |(\vec{p} \times \vec{q}) \times (\vec{r} \times \vec{t})| = \left| \frac{1}{2} \hat{k} \right| = \frac{1}{2} = 0.5$$

14. Given, $\vec{a} \times (\vec{a} \times \vec{c}) + \vec{b} = \vec{0}$

$$\Rightarrow (\vec{a} \cdot \vec{c}) \vec{a} - (\vec{a} \cdot \vec{a}) \vec{c} + \vec{b} = \vec{0}$$

$$\Rightarrow (2 \cos \theta) \vec{a} - \vec{c} + \vec{b} = \vec{0}$$

$$\Rightarrow (2 \cos \theta \vec{a} - \vec{c})^2 = (-\vec{b})^2$$

$$\Rightarrow 4 \cos^2 \theta \cdot |\vec{a}|^2 + |\vec{c}|^2 - 2 \cdot 2 \cos \theta \vec{a} \cdot \vec{c} = |\vec{b}|^2$$

$$\Rightarrow 4 \cos^2 \theta - 4 - 8 \cos^2 \theta = 1$$

$$\Rightarrow 4 \cos^2 \theta = 3$$

$$\Rightarrow \cos \theta = \pm \frac{\sqrt{3}}{2}$$

For θ to be acute, $\cos \theta = \frac{\sqrt{3}}{2} \Rightarrow \theta = \frac{\pi}{6}$

15. Now, $(\vec{A} + \vec{B}) \times (\vec{A} + \vec{C})$

$$= \vec{A} \times \vec{A} + \vec{B} \times \vec{A} + \vec{A} \times \vec{C} + \vec{B} \times \vec{C}$$

$$= \vec{B} \times \vec{A} + \vec{A} \times \vec{C} + \vec{B} \times \vec{C} \quad [\because \vec{A} \times \vec{A} = \vec{0}]$$

$$\therefore [(\vec{A} + \vec{B}) \times (\vec{A} + \vec{C})] \times (\vec{B} \times \vec{C})$$

$$= [\vec{B} \times \vec{A} + \vec{A} \times \vec{C} + \vec{B} \times \vec{C}] \times (\vec{B} \times \vec{C})$$

$$= (\vec{B} \times \vec{A}) \times (\vec{B} \times \vec{C}) + (\vec{A} \times \vec{C}) \times (\vec{B} \times \vec{C})$$

$$= \{(\vec{B} \times \vec{A}) \cdot \vec{C}\} \vec{B} - \{(\vec{B} \times \vec{A}) \cdot \vec{B}\} \vec{C}$$

$$+ \{(\vec{A} \times \vec{C}) \cdot \vec{C}\} \vec{B} - \{(\vec{A} \times \vec{C}) \cdot \vec{B}\} \vec{C}$$

$$[\because (\vec{a} \times \vec{b}) \times \vec{c} = (\vec{a} \cdot \vec{c}) \vec{b} - (\vec{b} \cdot \vec{c}) \vec{a}]$$

$$= [\vec{B} \vec{A} \vec{C}] \vec{B} - [\vec{A} \vec{C} \vec{B}] \vec{C}$$

$$[\because [\vec{a} \vec{b} \vec{c}] = 0, \text{ if any two of } \vec{a}, \vec{b}, \vec{c} \text{ are equal}]$$

$$= [\vec{A} \vec{C} \vec{B}] (\vec{B} - \vec{C})$$

Now, $[(\vec{A} + \vec{B}) \times (\vec{A} + \vec{C})] \times (\vec{B} \times \vec{C}) \cdot (\vec{B} + \vec{C})$

$$= ([\vec{A} \vec{C} \vec{B}] \{\vec{B} - \vec{C}\}) \cdot (\vec{B} + \vec{C})$$

$$= [\vec{A} \vec{C} \vec{B}] \{(\vec{B} - \vec{C}) \cdot (\vec{B} + \vec{C})\}$$

$$= [\vec{A} \vec{C} \vec{B}] \{|\vec{B}|^2 - |\vec{C}|^2\} = \vec{0} \quad [\because |\vec{B}| = |\vec{C}|, \text{ given}]$$

16. Considering first part $(\vec{a} \times \vec{b}) \times (\vec{c} \times \vec{d})$

Let $\vec{c} \times \vec{d} = \vec{e}$

$$(\vec{a} \times \vec{b}) \times \vec{e} = (\vec{a} \cdot \vec{e}) \vec{b} - (\vec{b} \cdot \vec{e}) \vec{a}$$

$$[\because (\vec{a} \times \vec{b}) \times \vec{c} = (\vec{a} \cdot \vec{c}) \vec{b} - (\vec{b} \cdot \vec{c}) \vec{a}]$$

$$= \{(\vec{a} \cdot (\vec{c} \times \vec{d}))\} \vec{b} - \{(\vec{b} \cdot (\vec{c} \times \vec{d}))\} \vec{a}$$

$$= [\vec{a} \vec{c} \vec{d}] \vec{b} - [\vec{b} \vec{c} \vec{d}] \vec{a} \quad \dots(i)$$

Similarly,

$$(\vec{a} \times \vec{c}) \times (\vec{d} \times \vec{b}) = [\vec{a} \vec{d} \vec{b}] \vec{c} - [\vec{c} \vec{d} \vec{b}] \vec{a}$$

$$= [\vec{a} \vec{d} \vec{b}] \vec{c} - [\vec{b} \vec{c} \vec{d}] \vec{a} \quad \dots(ii)$$

Also, $(\vec{a} \times \vec{d}) \times (\vec{b} \times \vec{c}) = -(\vec{b} \times \vec{c}) \times (\vec{a} \times \vec{d})$

$$= (\vec{b} \times \vec{c}) \times (\vec{d} \times \vec{a}) = [\vec{b} \vec{d} \vec{a}] \vec{c} - [\vec{c} \vec{d} \vec{a}] \vec{b}$$

$$= [\vec{a} \vec{d} \vec{b}] \vec{c} - [\vec{a} \vec{c} \vec{d}] \vec{b} \quad \dots(iii)$$

From Eqs. (i), (ii) and (iii),

$$(\vec{a} \times \vec{b}) \times (\vec{c} \times \vec{d}) + (\vec{a} \times \vec{c}) \times (\vec{d} \times \vec{b}) + (\vec{a} \times \vec{d}) \times (\vec{b} \times \vec{c})$$

$$= [\vec{a} \vec{c} \vec{d}] \vec{b} - [\vec{b} \vec{c} \vec{d}] \vec{a} + [\vec{a} \vec{d} \vec{b}] \vec{c} - [\vec{b} \vec{c} \vec{d}] \vec{a} - [\vec{a} \vec{d} \vec{b}] \vec{c}$$

$$- [\vec{a} \vec{c} \vec{d}] \vec{b} = -2 [\vec{b} \vec{c} \vec{d}] \vec{a}$$

\therefore Parallel to \vec{a} .

17. (i) Given, $\vec{A} \perp \vec{B} \Rightarrow \vec{A} \cdot \vec{B} = 0 \quad \dots(i)$

and $\vec{A} \times \vec{X} = \vec{B} \Rightarrow \vec{A} \cdot \vec{B} = 0$ and $\vec{X} \cdot \vec{B} = 0 \quad \dots(ii)$

Now, $[\vec{X} \vec{A} \vec{A} \times \vec{B}] = \vec{X} \cdot \{\vec{A} \times (\vec{A} \times \vec{B})\}$

$$= \vec{X} \cdot \{(\vec{A} \cdot \vec{B}) \vec{A} - (\vec{A} \cdot \vec{A}) \vec{B}\}$$

$$= (\vec{A} \cdot \vec{B}) (\vec{X} \cdot \vec{A}) - (\vec{A} \cdot \vec{A}) (\vec{X} \cdot \vec{B}) = 0$$

$\Rightarrow \vec{X}, \vec{A}, \vec{A} \times \vec{B}$ are coplanar.

So, \vec{X} can be represented as a linear combination of \vec{A} and $\vec{A} \times \vec{B}$. Let us consider, $\vec{X} = l\vec{A} + m(\vec{A} \times \vec{B})$

Since, $\vec{A} \cdot \vec{X} = c$

$$\therefore \vec{A} \cdot \{l\vec{A} + m(\vec{A} \times \vec{B})\} = c \Rightarrow l|\vec{A}|^2 + 0 = c$$

$$\Rightarrow l = \frac{c}{|\vec{A}|^2}$$

Also, $\vec{A} \times \vec{X} = \vec{B} \Rightarrow \vec{A} \times \{l\vec{A} + m(\vec{A} \times \vec{B})\} = \vec{B}$

$$\Rightarrow l(\vec{A} \times \vec{A}) + m\{\vec{A} \times (\vec{A} \times \vec{B})\} = \vec{B}$$

$$\Rightarrow 0 - m|\vec{A}|^2 \vec{B} = \vec{B}$$

$$\Rightarrow m = -\frac{1}{|\vec{A}|^2}$$

$$\therefore \vec{X} = \left(\frac{c}{|\vec{A}|^2} \right) \vec{A} - \left(\frac{1}{|\vec{A}|^2} \right) (\vec{A} \times \vec{B})$$

(ii) Since, vector \vec{A} has components A_1, A_2, A_3 in the coordinate system $OXYZ$.

$$\therefore \vec{A} = A_1\hat{i} + A_2\hat{j} + A_3\hat{k}$$

When the given system is rotated about an angle of $\pi/2$, the new X -axis is along old Y -axis and new Y -axis is along the old negative X -axis, whereas z remains same.

Hence, the components of A in the new system are $(A_2, -A_1, A_3)$.

$$\therefore \vec{A} \text{ becomes } (A_2\hat{i} - A_1\hat{j} + A_3\hat{k}).$$

Topic 5 Solving Equations and Reciprocal of Vectors

1. Two vectors \mathbf{c} and \mathbf{d} are said to be collinear if we can write $\mathbf{c} = \lambda\mathbf{b}$ for some non-zero scalar λ .

Let the vectors $\alpha = (\lambda - 2)\mathbf{a} + \mathbf{b}$

and $\beta = (4\lambda - 2)\mathbf{a} + 3\mathbf{b}$ are

collinear, where \mathbf{a} and \mathbf{b} are non-collinear.

\therefore We can write

$$\alpha = k\beta, \text{ for some } k \in R - \{0\}$$

$$\Rightarrow (\lambda - 2)\mathbf{a} + \mathbf{b} = k[(4\lambda - 2)\mathbf{a} + 3\mathbf{b}]$$

$$\Rightarrow [(\lambda - 2) - k(4\lambda - 2)]\mathbf{a} + (1 - 3k)\mathbf{b} = 0$$

Now, as \mathbf{a} and \mathbf{b} are non-collinear, therefore they are linearly independent and hence $(\lambda - 2) - k(4\lambda - 2) = 0$ and $1 - 3k = 0$

$$\Rightarrow \lambda - 2 = k(4\lambda - 2) \text{ and } 3k = 1$$

$$\Rightarrow \lambda - 2 = \frac{1}{3}(4\lambda - 2) \quad \left[\because 3k = 1 \Rightarrow k = \frac{1}{3} \right]$$

$$\Rightarrow 3\lambda - 6 = 4\lambda - 2 \Rightarrow \lambda = -4$$

2. We have, $\mathbf{a} = 2\hat{i} + \lambda_1\hat{j} + 3\hat{k}$; $\mathbf{b} = 4\hat{i} + (3 - \lambda_2)\hat{j} + 6\hat{k}$

and $\mathbf{c} = 3\hat{i} + 6\hat{j} + (\lambda_3 - 1)\hat{k}$,

such that $\mathbf{b} = 2\mathbf{a}$

Now, $\mathbf{b} = 2\mathbf{a}$

$$\Rightarrow 4\hat{i} + (3 - \lambda_2)\hat{j} + 6\hat{k} = 2(2\hat{i} + \lambda_1\hat{j} + 3\hat{k})$$

$$\Rightarrow 4\hat{i} + (3 - \lambda_2)\hat{j} + 6\hat{k} = 4\hat{i} + 2\lambda_1\hat{j} + 6\hat{k}$$

$$\Rightarrow (3 - 2\lambda_1 - \lambda_2)\hat{j} = 0$$

$$\Rightarrow 3 - 2\lambda_1 - \lambda_2 = 0$$

$$\Rightarrow 2\lambda_1 + \lambda_2 = 3 \quad \dots (i)$$

Also, as \mathbf{a} is perpendicular to \mathbf{c} , therefore $\mathbf{a} \cdot \mathbf{c} = 0$

$$\Rightarrow (2\hat{i} + \lambda_1\hat{j} + 3\hat{k}) \cdot (3\hat{i} + 6\hat{j} + (\lambda_3 - 1)\hat{k}) = 0$$

$$\Rightarrow 6 + 6\lambda_1 + 3(\lambda_3 - 1) = 0$$

$$\Rightarrow 6\lambda_1 + 3\lambda_3 + 3 = 0$$

$$\Rightarrow 2\lambda_1 + \lambda_3 = -1 \quad \dots (ii)$$

Now, from Eq. (i), $\lambda_2 = 3 - 2\lambda_1$ and from Eq. (ii)

$$\lambda_3 = -2\lambda_1 - 1$$

$$\therefore (\lambda_1, \lambda_2, \lambda_3) \equiv (\lambda_1, 3 - 2\lambda_1, -2\lambda_1 - 1)$$

If $\lambda_1 = -\frac{1}{2}$, then $\lambda_2 = 4$, and $\lambda_3 = 0$

Thus, a possible value of $(\lambda_1, \lambda_2, \lambda_3) = \left(-\frac{1}{2}, 4, 0\right)$

3. It is given that \vec{c} is coplanar with \vec{a} and \vec{b} , we take

$$\vec{c} = p\vec{a} + q\vec{b} \quad \dots(i)$$

where, p and q are scalars.

$$\text{Since, } \vec{c} \perp \vec{a} \Rightarrow \vec{c} \cdot \vec{a} = 0$$

Taking dot product of \vec{a} in Eq. (i), we get

$$\vec{c} \cdot \vec{a} = p\vec{a} \cdot \vec{a} + q\vec{b} \cdot \vec{a} \Rightarrow 0 = p|\vec{a}|^2 + q|\vec{b} \cdot \vec{a}|$$

$$\left[\begin{array}{l} \because \vec{a} = 2\hat{i} + \hat{j} + \hat{k} \\ |\vec{a}| = \sqrt{2^2 + 1 + 1} = \sqrt{6}. \\ \vec{a} \cdot \vec{b} = (2\hat{i} + \hat{j} + \hat{k}) \cdot (\hat{i} + 2\hat{j} - \hat{k}) \\ = 2 + 2 - 1 = 3 \end{array} \right]$$

$$\Rightarrow 0 = p \cdot 6 + q \cdot 3 \Rightarrow q = -2p$$

On putting in Eq. (i), we get

$$\vec{c} = p\vec{a} + \vec{b}(-2p)$$

$$\Rightarrow \vec{c} = p\vec{a} - 2p\vec{b} \Rightarrow \vec{c} = p(\vec{a} - 2\vec{b})$$

$$\Rightarrow \vec{c} = p[(2\hat{i} + \hat{j} + \hat{k}) - 2(\hat{i} + 2\hat{j} - \hat{k})]$$

$$\Rightarrow \vec{c} = p(-3\hat{j} + 3\hat{k}) \Rightarrow |\vec{c}| = p\sqrt{(-3)^2 + 3^2}$$

$$\Rightarrow |\vec{c}|^2 = p^2(\sqrt{18})^2 \Rightarrow |\vec{c}|^2 = p^2 \cdot 18$$

$$\Rightarrow 1 = p^2 \cdot 18 \quad [:\ |\vec{c}| = 1]$$

$$\Rightarrow p^2 = \frac{1}{18} \Rightarrow p = \pm \frac{1}{3\sqrt{2}}$$

$$\therefore \vec{c} = \pm \frac{1(-\hat{j} + \hat{k})}{\sqrt{2}}$$

4. Since, $\vec{p}, \vec{q}, \vec{r}$ are mutually perpendicular vectors of same magnitude, so let us consider

$$\left. \begin{array}{l} |\vec{p}| = |\vec{q}| = |\vec{r}| = \lambda \text{ and} \\ \vec{p} \cdot \vec{q} = \vec{q} \cdot \vec{r} = \vec{r} \cdot \vec{p} = 0 \end{array} \right\} \quad \dots(i)$$

Given, $\vec{p} \times \{(\vec{x} - \vec{q}) \times \vec{p}\} + \vec{q} \times \{(\vec{x} - \vec{r}) \times \vec{q}\}$

$$+ \vec{r} \times \{(\vec{x} - \vec{p}) \times \vec{r}\} = \vec{0}$$

$$\Rightarrow (\vec{p} \cdot \vec{p})(\vec{x} - \vec{q}) - \{\vec{p} \cdot (\vec{x} - \vec{q})\}\vec{p} + (\vec{q} \cdot \vec{q})(\vec{x} - \vec{r})$$

$$- \{\vec{q} \cdot (\vec{x} - \vec{r})\}\vec{q} + (\vec{r} \cdot \vec{r})(\vec{x} - \vec{p}) - \{\vec{r} \cdot (\vec{x} - \vec{p})\}\vec{r} = 0$$

$$\Rightarrow \vec{x}\{(\vec{p} \cdot \vec{p}) + (\vec{q} \cdot \vec{q}) + (\vec{r} \cdot \vec{r})\} - (\vec{p} \cdot \vec{p})\vec{q}$$

$$- (\vec{q} \cdot \vec{q})\vec{r} - (\vec{r} \cdot \vec{r})\vec{p} = (\vec{x} \cdot \vec{p})\vec{p} + (\vec{x} \cdot \vec{q})\vec{q} + (\vec{x} \cdot \vec{r})\vec{r}$$

$$\Rightarrow 3\vec{x}|\lambda|^2 - (\vec{p} + \vec{q} + \vec{r})|\lambda|^2 = (\vec{x} \cdot \vec{p})\vec{p}$$

$$+ (\vec{x} \cdot \vec{q})\vec{q} + (\vec{x} \cdot \vec{r})\vec{r} \quad \dots(ii)$$

Taking dot of Eq. (ii) with \vec{p} , we get

$$3(\vec{x} \cdot \vec{p})|\lambda|^2 - |\lambda|^4 = (\vec{x} \cdot \vec{p})|\lambda|^2 \Rightarrow \vec{x} \cdot \vec{p} = \frac{1}{2}|\lambda|^2$$

576 Vectors

Similarly, taking dot of Eq. (ii) with \vec{q} and \vec{r} respectively, we get

$$\vec{x} \cdot \vec{q} = \frac{|\lambda|^2}{2} = \vec{x} \cdot \vec{r}$$

\therefore Eq. (ii) becomes

$$\begin{aligned} 3 \vec{x} |\lambda|^2 - (\vec{p} + \vec{q} + \vec{r}) |\lambda|^2 &= \frac{|\lambda|^2}{2} (\vec{p} + \vec{q} + \vec{r}) \\ \Rightarrow 3 \vec{x} &= \frac{1}{2} (\vec{p} + \vec{q} + \vec{r}) + (\vec{p} + \vec{q} + \vec{r}) \\ \Rightarrow \vec{x} &= \frac{1}{2} (\vec{p} + \vec{q} + \vec{r}) \end{aligned}$$

5. Equation of the plane containing \hat{i} and $\hat{i} + \hat{j}$ is

$$\begin{aligned} [(\vec{r} - \hat{i}) \cdot \hat{i} \quad (\hat{i} + \hat{j})] &= 0 \\ \Rightarrow (\vec{r} - \hat{i}) \cdot [\hat{i} \times (\hat{i} + \hat{j})] &= 0 \\ \Rightarrow \{(x\hat{i} + y\hat{j} + z\hat{k}) - \hat{i}\} \cdot [\hat{i} \times \hat{i} + \hat{i} \times \hat{j}] &= 0 \\ \Rightarrow \{(x-1)\hat{i} + y\hat{j} + z\hat{k}\} \cdot [\hat{k}] &= 0 \\ \Rightarrow (x-1)\hat{i} \cdot \hat{k} + y\hat{j} \cdot \hat{k} + z\hat{k} \cdot \hat{k} &= 0 \\ \Rightarrow z &= 0 \quad \dots(i) \end{aligned}$$

Equation of the plane containing $\hat{i} - \hat{j}$ and $\hat{i} + \hat{k}$ is

$$\begin{aligned} [(\vec{r} - (\hat{i} - \hat{j})) \cdot (\hat{i} - \hat{j}) \quad (\hat{i} + \hat{k})] &= 0 \\ \Rightarrow (\vec{r} - \hat{i} + \hat{j}) \cdot [(\hat{i} - \hat{j}) \times (\hat{i} + \hat{k})] &= 0 \\ \Rightarrow \{(x\hat{i} + y\hat{j} + z\hat{k}) - (\hat{i} - \hat{j})\} \cdot [\hat{i} \times \hat{i} + \hat{i} \times \hat{k} - \hat{j} \times \hat{i} - \hat{j} \times \hat{k}] &= 0 \\ \Rightarrow \{(x-1)\hat{i} + (y+1)\hat{j} + z\hat{k}\} \cdot [-\hat{j} + \hat{k} - \hat{i}] &= 0 \\ \Rightarrow -(x-1) - (y+1) + z &= 0 \quad \dots(ii) \end{aligned}$$

Let $\vec{a} = a_1\hat{i} + a_2\hat{j} + a_3\hat{k}$

Since, \vec{a} is parallel to Eqs. (i) and (ii), we obtain

$$\begin{aligned} a_3 &= 0 \\ \text{and } a_1 + a_2 - a_3 &= 0 \\ \Rightarrow a_1 &= -a_2, a_3 = 0 \end{aligned}$$

Thus, a vector in the direction \vec{a} is $\hat{i} - \hat{j}$.

If θ is the angle between \vec{a} and $\hat{i} - 2\hat{j} + 2\hat{k}$, then

$$\begin{aligned} \cos \theta &= \pm \frac{(1)(1) + (-1)(-2)}{\sqrt{1+1}\sqrt{1+4+4}} = \pm \frac{3}{\sqrt{2} \cdot 3} \\ \Rightarrow \cos \theta &= \pm \frac{1}{\sqrt{2}} \Rightarrow \theta = \frac{\pi}{4} \text{ or } \frac{3\pi}{4} \end{aligned}$$

6. Any vector coplanar with $\hat{i} + \hat{j} + 2\hat{k}$ and $\hat{i} + 2\hat{j} + \hat{k}$ is given by

$$\begin{aligned} \vec{a} &= x(\hat{i} + \hat{j} + 2\hat{k}) + y(\hat{i} + 2\hat{j} + \hat{k}) \\ &= (x+y)\hat{i} + (x+2y)\hat{j} + (2x+y)\hat{k} \end{aligned}$$

This vector is perpendicular to $\hat{i} + \hat{j} + \hat{k}$, if

$$(x+y)1 + (x+2y)1 + (2x+y)1 = 0$$

$$\Rightarrow 4x + 4y = 0 \Rightarrow -x = y$$

$$\therefore \vec{a} = -x\hat{j} + x\hat{k} = x(-\hat{j} + \hat{k}) \Rightarrow |\vec{a}| = \sqrt{2}|x|$$

Hence, the required unit vector is $\hat{a} = \pm \frac{1}{\sqrt{2}}(-\hat{j} + \hat{k})$

7. Let $\vec{c} = a\hat{i} + b\hat{j}$

Since, \vec{b} and \vec{c} are perpendicular to each other. Then,

$$\vec{b} \cdot \vec{c} = 0 \Rightarrow (4\hat{i} + 3\hat{j}) \cdot (a\hat{i} + b\hat{j}) = 0$$

$$\Rightarrow 4a + 3b = 0 \Rightarrow a : b = 3 : -4$$

$\therefore \vec{c} = \lambda(3\hat{i} - 4\hat{j})$, where λ is constant of ratio.

Let the required vectors be $\vec{a} = p\hat{i} + q\hat{j}$

Projection of \vec{a} on \vec{b} is $\frac{\vec{a} \cdot \vec{b}}{|\vec{b}|}$

$$\therefore 1 = \frac{4p + 3q}{5} \Rightarrow 4p + 3q = 5 \quad \dots(i)$$

Also, projection of \vec{a} on \vec{c} is $\frac{\vec{a} \cdot \vec{c}}{|\vec{c}|}$.

$$\Rightarrow 2 = \frac{3\lambda p - 4\lambda q}{5\lambda} \Rightarrow 3p - 4q = 10$$

On solving above equations, we get $p = 2, q = -1$

$$\therefore \vec{c} = 2\hat{i} - \hat{j}$$

8. Let $\vec{B} = x\hat{i} + y\hat{j} + z\hat{k}$

Given, $\vec{A} = \hat{i} + \hat{j} + \hat{k}, \vec{C} = \hat{j} - \hat{k}$

Also, given $\vec{A} \times \vec{B} = \vec{C}$

$$\Rightarrow (z-y)\hat{i} - (z-x)\hat{j} + (y-x)\hat{k} = \hat{j} - \hat{k}$$

$$\Rightarrow z - y = 0, x - z = 1, y - x = -1$$

Also, $\vec{A} \cdot \vec{B} = 3 \Rightarrow x + y + z = 3$

On solving above equations, we get

$$x = \frac{5}{3}, y = z = \frac{2}{3}$$

$$\therefore \vec{B} = \left(\frac{5}{3}\hat{i}, \frac{2}{3}\hat{j}, \frac{2}{3}\hat{k}\right)$$

9. Since, \hat{v} is unit vector along the incident ray and \hat{w} is the unit vector along the reflected ray.

Hence, \hat{a} is a unit vector along the external bisector of \hat{v} and \hat{w} .

$$\therefore \hat{w} - \hat{v} = \lambda \hat{a}$$

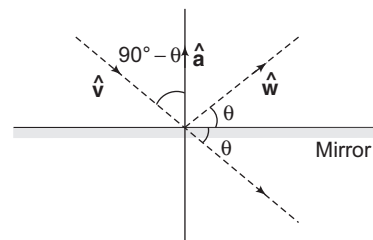

On squaring both sides, we get

$$\Rightarrow 1 + 1 - \hat{w} \cdot \hat{v} = \lambda^2 \Rightarrow 2 - 2 \cos 2\theta = \lambda^2$$

$$\Rightarrow \lambda = 2 \sin \theta$$

where, 2θ is the angle between \hat{v} and \hat{w} .

Hence, $\hat{w} - \hat{v} = 2 \sin \theta \cdot \hat{a} = 2 \cos (90^\circ - \theta) \hat{a} = - (2 \hat{a} \cdot \hat{v}) \hat{a}$

$$\Rightarrow \hat{w} = \hat{v} - 2 (\hat{a} \cdot \hat{v}) \hat{a}$$

10. Let the position vectors of A, B, C be \vec{a}, \vec{b} and \vec{c} respectively and that of P, Q, R be \vec{p}, \vec{q} and \vec{r} , respectively. Let \vec{h} be the position vector of the orthocentre H of the ΔPQR . We have, $HP \perp QR$. Equation of straight line passing through A and perpendicular to QR i.e. parallel to $\vec{HP} = \vec{P} - \vec{h}$ is

$$\vec{r} = \vec{a} + t_1 (\vec{p} - \vec{h}) \quad \dots(i)$$

where, t_1 is a parameter.

Similarly, equation of straight line through B and perpendicular to RP is $\vec{r} = \vec{b} + t_2 (\vec{q} - \vec{h}) \quad \dots(ii)$

Again, equation of straight line through C and perpendicular to PQ is $\vec{r} = \vec{c} + t_3 (\vec{r} - \vec{h}) \quad \dots(iii)$

If the lines (i), (ii) and (iii) are concurrent, then there exists a point D with position vector \vec{d} which lies on all of them, that is for some values of t_1, t_2 and t_3 , which implies that

$$\frac{1}{t_1} \vec{d} = \frac{1}{t_1} \vec{a} + \vec{p} - \vec{h} \quad \dots(iv)$$

$$\frac{1}{t_2} \vec{d} = \frac{1}{t_2} \vec{b} + \vec{q} - \vec{h} \quad \dots(v)$$

$$\frac{1}{t_3} \vec{d} = \frac{1}{t_3} \vec{c} + \vec{r} - \vec{h} \quad \dots(vi)$$

From Eqs. (iv) and (v),

$$\left(\frac{1}{t_1} - \frac{1}{t_2} \right) \vec{d} = \frac{1}{t_1} \vec{a} - \frac{1}{t_2} \vec{b} + \vec{p} - \vec{q} \quad \dots(vii)$$

and from Eqs. (v) and (vi),

$$\left(\frac{1}{t_2} - \frac{1}{t_3} \right) \vec{d} = \frac{1}{t_2} \vec{b} - \frac{1}{t_3} \vec{c} + \vec{q} - \vec{r} \quad \dots(viii)$$

Eliminating \vec{d} from Eqs. (vii) and (viii), we get

$$\left(\frac{1}{t_2} - \frac{1}{t_3} \right) \left[\frac{1}{t_1} \vec{a} - \frac{1}{t_2} \vec{b} + \vec{p} - \vec{q} \right]$$

$$= \left(\frac{1}{t_1} - \frac{1}{t_2} \right) \left[\frac{1}{t_2} \vec{b} - \frac{1}{t_3} \vec{c} + \vec{q} - \vec{r} \right]$$

$$\Rightarrow (t_3 - t_2) [t_2 \vec{a} - t_1 \vec{b} + t_1 t_2 (\vec{p} - \vec{q})]$$

$$= (t_2 - t_1) [t_3 \vec{b} - t_2 \vec{c} + t_2 t_3 (\vec{q} - \vec{r})]$$

[multiplying both sides by $t_1 t_2 t_3$]

$$\Rightarrow t_2 (t_3 - t_2) \vec{a} + t_2 (t_1 - t_3) \vec{b}$$

$$+ t_2 (t_2 - t_1) \vec{c} + t_1 t_2 (t_3 - t_2) \vec{p}$$

$$+ t_2^2 (t_1 - t_3) \vec{q} + t_2 t_3 (t_2 - t_1) \vec{r} = \vec{0}$$

Thus, lines (i), (ii), and (iii) are concurrent is equivalent to say that there exist scalars t_1, t_2 and t_3 such that

$$(t_2 - t_3) \vec{a} + (t_3 - t_1) \vec{b} + (t_1 - t_2) \vec{c} + t_1 (t_2 - t_3) \vec{p}$$

$$+ t_2 (t_3 - t_1) \vec{q} + t_3 (t_1 - t_2) \vec{r} = \vec{0}$$

On dividing by $t_1 t_2 t_3$, we get

$$(\lambda_2 - \lambda_3) \vec{p} + (\lambda_3 - \lambda_1) \vec{q} + (\lambda_1 - \lambda_2) \vec{r}$$

$$+ \lambda_1 (\lambda_2 - \lambda_3) \vec{a} + \lambda_2 (\lambda_3 - \lambda_1) \vec{b} + \lambda_3 (\lambda_1 - \lambda_2) \vec{c} = 0$$

where, $\lambda_i = \frac{1}{t_i}$ for $i = 1, 2, 3$

So, this is the condition that the lines from P perpendicular to BC , from Q , perpendicular to CA and from R perpendicular to AB are concurrent (by changing ABC and PQR simultaneously).

11. F is mid-point of BC i.e. $F = \frac{\hat{i} + 3\hat{i}}{2} = 2\hat{i}$ and $AE \perp DE$ [given]

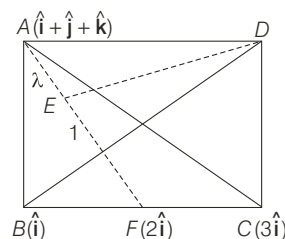

Let E divides AF in $\lambda : 1$. The position vector of E is given by

$$\frac{2\lambda\hat{i} + 1(\hat{i} + \hat{j} + \hat{k})}{\lambda + 1} = \left(\frac{2\lambda + 1}{\lambda + 1} \right) \hat{i} + \frac{1}{\lambda + 1} \hat{j} + \frac{1}{\lambda + 1} \hat{k}$$

Now, volume of the tetrahedron

$$= \frac{1}{3} (\text{area of the base}) (\text{height})$$

$$\Rightarrow \frac{2\sqrt{2}}{3} = \frac{1}{3} (\text{area of the } \Delta ABC) (DE)$$

But area of the $\Delta ABC = \frac{1}{2} |\vec{BC} \times \vec{BA}|$

$$= \frac{1}{2} |2\hat{i} \times (\hat{j} + \hat{k})| = |\hat{i} \times \hat{j} + \hat{i} \times \hat{k}| = |\hat{k} - \hat{j}| = \sqrt{2}$$

$$\therefore \frac{2\sqrt{2}}{3} = \frac{1}{3} (\sqrt{2}) (DE) \Rightarrow DE = 2$$

Since, ΔADE is a right angle triangle, then

$$AD^2 = AE^2 + DE^2$$

$$\Rightarrow (4)^2 = AE^2 + (2)^2$$

$$\Rightarrow AE^2 = 12$$

But $\vec{AE} = \frac{2\lambda + 1}{\lambda + 1} \hat{i} + \frac{1}{\lambda + 1} \hat{j} + \frac{1}{\lambda + 1} \hat{k} - (\hat{i} + \hat{j} + \hat{k})$

$$= \frac{\lambda}{\lambda + 1} \hat{i} - \frac{\lambda}{\lambda + 1} \hat{j} - \frac{\lambda}{\lambda + 1} \hat{k}$$

$$\Rightarrow |\vec{AE}|^2 = \frac{1}{(\lambda + 1)^2} [\lambda^2 + \lambda^2 + \lambda^2] = \frac{3\lambda^2}{(\lambda + 1)^2}$$

578 Vectors

$$\text{Therefore, } 12 = \frac{3\lambda^2}{(\lambda + 1)^2}$$

$$\Rightarrow 4(\lambda + 1)^2 = \lambda^2$$

$$\Rightarrow 4\lambda^2 + 4 + 8\lambda = \lambda^2$$

$$\Rightarrow 3\lambda^2 + 8\lambda + 4 = 0$$

$$\Rightarrow 3\lambda^2 + 6\lambda + 2\lambda + 4 = 0$$

$$\Rightarrow 3\lambda(\lambda + 2) + 2(\lambda + 2) = 0$$

$$\Rightarrow (3\lambda + 2)(\lambda + 2) = 0$$

$$\Rightarrow \lambda = -2/3, \lambda = -2$$

When $\lambda = -2/3$, position vector of E is given by

$$\begin{aligned} & \left(\frac{2\lambda + 1}{\lambda + 1} \right) \hat{i} + \frac{1}{\lambda + 1} \hat{j} + \frac{1}{\lambda + 1} \hat{k} \\ &= \frac{2 \cdot (-2/3) + 1}{-2/3 + 1} \hat{i} + \frac{1}{-2/3 + 1} \hat{j} + \frac{1}{-2/3 + 1} \hat{k} \\ &= \frac{-4/3 + 1}{-2 + 3} \hat{i} + \frac{1}{-2 + 3} \hat{j} + \frac{1}{-2 + 3} \hat{k} \\ &= \frac{-4 + 3}{3} \hat{i} + \frac{1}{3} \hat{j} + \frac{1}{3} \hat{k} \\ &= \frac{-1}{3} \hat{i} + \frac{1}{3} \hat{j} + \frac{1}{3} \hat{k} = -\hat{i} + \hat{j} + \hat{k} \end{aligned}$$

and when $\lambda = -2$, position vector of E is given by,

$$\begin{aligned} & \frac{2 \times (-2) + 1}{-2 + 1} \hat{i} + \frac{1}{-2 + 1} \hat{j} + \frac{1}{-2 + 1} \hat{k} = \frac{-4 + 1}{-1} \hat{i} - \hat{j} - \hat{k} \\ &= 3\hat{i} - \hat{j} - \hat{k} \end{aligned}$$

Therefore, $-\hat{i} + \hat{j} + \hat{k}$ and $3\hat{i} - \hat{j} - \hat{k}$ are the answer.

12. Let O be the origin of reference. Let the position vectors of A and B be \vec{a} and \vec{b} respectively.

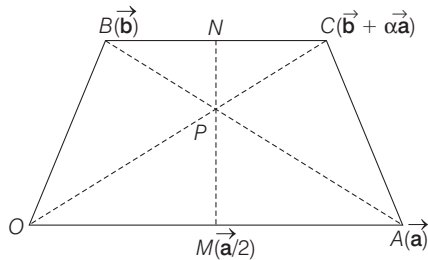

Since, $BC \parallel OA$, $\vec{BC} = \alpha \vec{OA} = \alpha \vec{a}$ for some constant α .

Equation of OC is $\vec{r} = t(\vec{b} + \alpha \vec{a})$ and

equation of AB is $\vec{r} = \vec{a} + \lambda(\vec{b} - \vec{a})$

Let P be the point of intersection of OC and AB . Then, at point P , $t(\vec{b} + \alpha \vec{a}) = \vec{a} + \lambda(\vec{b} - \vec{a})$ for some values of t and λ .

$$\Rightarrow (t\alpha - 1 + \lambda) \vec{a} = (\lambda - t) \vec{b}$$

Since, \vec{a} and \vec{b} are non-parallel vectors, we must have

$$t\alpha - 1 + \lambda = 0 \quad \text{and} \quad \lambda = t \Rightarrow t = 1/(\alpha + 1)$$

Thus, position vector of P is $\vec{r}_1 = \frac{1}{\alpha + 1}(\vec{b} + \alpha \vec{a})$

$$\text{Equation of } MN \text{ is } \vec{r} = \frac{1}{2} \vec{a} + k \left[\vec{b} + \frac{1}{2}(\alpha - 1) \vec{a} \right] \quad \dots(i)$$

For $k = 1/(\alpha + 1)$ {which is the coefficient of \vec{b} in \vec{r}_1 }, we get

$$\begin{aligned} \vec{r} &= \frac{1}{2} \vec{a} + \frac{1}{\alpha + 1} \left[\vec{b} + \frac{1}{2}(\alpha - 1) \vec{a} \right] \\ &= \frac{1}{(\alpha + 1)} \vec{b} + \frac{1}{2}(\alpha - 1) \cdot \frac{1}{\alpha + 1} \vec{a} + \frac{1}{2} \vec{a} \\ &= \frac{1}{(\alpha + 1)} \vec{b} + \frac{1}{2(\alpha + 1)} (\alpha - 1 + \alpha + 1) \vec{a} \\ &= \frac{1}{(\alpha + 1)} (\vec{b} + \alpha \vec{a}) = \vec{r}_1 \end{aligned}$$

$\Rightarrow P$ lies on MN .

13. Since, $\vec{a}, \vec{b}, \vec{c}$ are non-coplanar vectors.

$$\Rightarrow [\vec{a} \vec{b} \vec{c}] \neq 0$$

$$\text{Also, } \vec{a} \times \vec{b} + \vec{b} \times \vec{c} = p \vec{a} + q \vec{b} + r \vec{c}$$

Taking dot product with \vec{a}, \vec{b} and \vec{c} respectively both sides, we get

$$p + q \cos \theta + r \cos \theta = [\vec{a} \vec{b} \vec{c}] \quad \dots (i)$$

$$p \cos \theta + q + r \cos \theta = 0 \quad \dots (ii)$$

$$\text{and } p \cos \theta + q \cos \theta + r = [\vec{a} \vec{b} \vec{c}] \quad \dots (iii)$$

On adding above equations,

$$p + q + r = \frac{2[\vec{a} \vec{b} \vec{c}]}{2 \cos \theta + 1} \quad \dots (iv)$$

On multiplying Eq. (iv) by $\cos \theta$ and subtracting Eq. (i), we get

$$p(\cos \theta - 1) = \frac{2[\vec{a} \vec{b} \vec{c}] \cos \theta}{2 \cos \theta + 1} - [\vec{a} \vec{b} \vec{c}]$$

$$\Rightarrow p = \frac{[\vec{a} \vec{b} \vec{c}]}{(1 - \cos \theta)(2 \cos \theta + 1)}$$

$$\text{Similarly, } q = \frac{-2[\vec{a} \vec{b} \vec{c}] \cos \theta}{(1 + 2 \cos \theta)(1 - \cos \theta)}$$

$$\text{and } r = \frac{[\vec{a} \vec{b} \vec{c}]}{(1 + 2 \cos \theta)(1 - \cos \theta)}$$

$$\text{Now, } [\vec{a} \vec{b} \vec{c}]^2 = \begin{vmatrix} \vec{a} \cdot \vec{a} & \vec{a} \cdot \vec{b} & \vec{a} \cdot \vec{c} \\ \vec{b} \cdot \vec{a} & \vec{b} \cdot \vec{b} & \vec{b} \cdot \vec{c} \\ \vec{c} \cdot \vec{a} & \vec{c} \cdot \vec{b} & \vec{c} \cdot \vec{c} \end{vmatrix} = \begin{vmatrix} 1 & \cos \theta & \cos \theta \\ \cos \theta & 1 & \cos \theta \\ \cos \theta & \cos \theta & 1 \end{vmatrix}$$

Applying $R_1 \rightarrow R_1 + R_2 + R_3$

$$= (1 + 2 \cos \theta) \begin{vmatrix} 1 & 1 & 1 \\ \cos \theta & 1 & \cos \theta \\ \cos \theta & \cos \theta & 1 \end{vmatrix}$$

Applying $C_2 \rightarrow C_2 - C_1, C_3 \rightarrow C_3 - C_1$

$$= (1 + 2 \cos \theta) \cdot \begin{vmatrix} 1 & 0 & 0 \\ \cos \theta & 1 - \cos \theta & 0 \\ \cos \theta & 0 & 1 - \cos \theta \end{vmatrix}$$

$$= (1 + 2 \cos \theta) \cdot (1 - \cos \theta)^2$$

$$\Rightarrow [\vec{a} \vec{b} \vec{c}] = (\sqrt{1 + 2 \cos \theta}) \cdot (1 - \cos \theta)$$

$$\therefore p = \frac{1}{\sqrt{1 + 2 \cos \theta}}, q = \frac{-2 \cos \theta}{\sqrt{1 + 2 \cos \theta}}$$

and $r = \frac{1}{\sqrt{1 + 2 \cos \theta}}$

14. Let $\vec{R} = x\hat{i} + y\hat{j} + z\hat{k}$

$$\therefore \vec{R} \times \vec{B} = \vec{C} \times \vec{B}$$

$$\Rightarrow \begin{vmatrix} \hat{i} & \hat{j} & \hat{k} \\ x & y & z \\ 1 & 1 & 1 \end{vmatrix} = \begin{vmatrix} \hat{i} & \hat{j} & \hat{k} \\ 4 & -3 & 7 \\ 1 & 1 & 1 \end{vmatrix}$$

$$\Rightarrow (y - z)\hat{i} - (x - z)\hat{j} + (x - y)\hat{k} = -10\hat{i} - 3\hat{j} + 7\hat{k}$$

$$\Rightarrow y - z = -10, z - x = -3, x - y = 7$$

and $\vec{R} \cdot \vec{A} = 0 \Rightarrow 2x + z = 0$

On solving above equations, $x = -1, y = -8$ and $z = 2$

$$\therefore \vec{R} = -\hat{i} - 8\hat{j} + 2\hat{k}$$

15. Given that, $\vec{a} \vec{b} \vec{c}$ are coplanar vectors.

\therefore There exists scalars x, y, z not all zero, such that

$$x\vec{a} + y\vec{b} + z\vec{c} = 0 \quad \dots(i)$$

Taking dot with \vec{a} and \vec{b} respectively, we get

$$x(\vec{a} \cdot \vec{a}) + y(\vec{a} \cdot \vec{b}) + z(\vec{a} \cdot \vec{c}) = 0 \quad \dots(ii)$$

and $x(\vec{a} \cdot \vec{b}) + y(\vec{b} \cdot \vec{b}) + z(\vec{c} \cdot \vec{b}) = 0 \quad \dots(iii)$

Since, Eqs. (i), (ii) and (iii) represent homogeneous equations with $(x, y, z) \neq (0, 0, 0)$.

\Rightarrow Non-trivial solutions

$$\therefore \Delta = 0 \Rightarrow \begin{vmatrix} \vec{a} & \vec{b} & \vec{c} \\ \vec{a} \cdot \vec{a} & \vec{a} \cdot \vec{b} & \vec{a} \cdot \vec{c} \\ \vec{b} \cdot \vec{a} & \vec{b} \cdot \vec{b} & \vec{b} \cdot \vec{c} \end{vmatrix} = \vec{0}$$

16. Since, $(\hat{i} + \hat{j} + 3\hat{k})x + (3\hat{i} - 3\hat{j} + \hat{k})y + (-4\hat{i} + 5\hat{j})z = \lambda(\hat{i}x + \hat{j}y + \hat{k}z)$

$$\Rightarrow x + 3y - 4z = \lambda x, x - 3y + 5z = \lambda y, 3x + y + 0z = \lambda z$$

$$\Rightarrow (1 - \lambda)x + 3y - 4z = 0, x - (3 + \lambda)y + 5z = 0,$$

$$3x + y - \lambda z = 0$$

Since, $(x, y, z) \neq (0, 0, 0)$

\therefore Non-trivial solution.

$$\Rightarrow \Delta = 0$$

$$\Rightarrow \begin{vmatrix} 1 - \lambda & 3 & -4 \\ 1 & -(3 + \lambda) & 5 \\ 3 & 1 & -\lambda \end{vmatrix} = 0$$

$$\Rightarrow (1 - \lambda)(3\lambda + \lambda^2 - 5) - 3(-\lambda - 15) - 4(1 + 9 + 3\lambda) = 0$$

$$\Rightarrow -\lambda^3 - 2\lambda^2 - \lambda = 0 \Rightarrow \lambda(\lambda + 1)^2 = 0$$

$$\therefore \lambda = 0, -1$$

25

3D Geometry

Topic 1 Direction Cosines and Direction Ratios of a Line

Objective Question I (Only one correct option)

1. The angle between the lines whose direction cosines satisfy the equations $l + m + n = 0$ and $l^2 = m^2 + n^2$, is (2014 Main)
- (a) $\frac{\pi}{3}$ (b) $\frac{\pi}{4}$ (c) $\frac{\pi}{6}$ (d) $\frac{\pi}{2}$

Topic 2 Straight Line in Space and Shortest Distance

Objective Questions I (Only one correct option)

1. The distance of the point having position vector $-\hat{i} + 2\hat{j} + 6\hat{k}$ from the straight line passing through the point $(2, 3, -4)$ and parallel to the vector, $6\hat{i} + 3\hat{j} - 4\hat{k}$ is (2019 Main, 10 April II)
- (a) $2\sqrt{13}$ (b) $4\sqrt{3}$ (c) 6 (d) 7
2. The vertices B and C of a ΔABC lie on the line, $\frac{x+2}{3} = \frac{y-1}{0} = \frac{z}{4}$ such that $BC = 5$ units. Then, the area (in sq units) of this triangle, given that the point $A(1, -1, 2)$ is (2019 Main, 9 April II)
- (a) $\sqrt{34}$ (b) $2\sqrt{34}$
(c) $5\sqrt{17}$ (d) 6
3. Let $\sqrt{3}\hat{i} + \hat{j}$, $\hat{i} + \sqrt{3}\hat{j}$ and $\beta\hat{i} + (1-\beta)\hat{j}$ respectively be the position vectors of the points A , B and C with respect to the origin O . If the distance of C from the bisector of the acute angle between OA and OB is $\frac{3}{\sqrt{2}}$, then the sum of all possible values of β is (2019 Main, 11 Jan II)
- (a) 1 (b) 3 (c) 4 (d) 2
4. If the line, $\frac{x-3}{2} = \frac{y+2}{-1} = \frac{z+4}{3}$ lies in the plane, $lx + my - z = 9$, then $l^2 + m^2$ is equal to (2016 Main)
- (a) 26 (b) 18
(c) 5 (d) 2
5. If the lines $\frac{x-2}{1} = \frac{y-3}{1} = \frac{z-4}{-k}$ and $\frac{x-1}{k} = \frac{y-4}{2} = \frac{z-5}{1}$ are coplanar, then k can have (2012 Main)
- (a) any value
(b) exactly one value
(c) exactly two values
(d) exactly three values

6. If the lines $\frac{x-1}{2} = \frac{y+1}{3} = \frac{z-1}{4}$ and $\frac{x-3}{1} = \frac{y-k}{2} = \frac{z}{1}$ intersect, then the value of k is (2004, 1M)
- (a) $\frac{3}{2}$ (b) $\frac{9}{2}$
(c) $-\frac{2}{9}$ (d) $-\frac{3}{2}$

Objective Questions II

(One or more than one correct option)

7. Let L_1 and L_2 be the following straight lines.

$$L_1: \frac{x-1}{1} = \frac{y}{-1} = \frac{z-1}{3} \text{ and } L_2: \frac{x-1}{-3} = \frac{y}{-1} = \frac{z-1}{1}.$$

Suppose the straight line

$$L: \frac{x-\alpha}{l} = \frac{y-1}{m} = \frac{z-\gamma}{-2}$$

lies in the plane containing L_1 and L_2 and passes through the point of intersection of L_1 and L_2 . If the line L bisects the acute angle between the lines L_1 and L_2 , then which of the following statements is/are TRUE?

- (a) $\alpha - \gamma = 3$ (b) $l + m = 2$ (2020 Adv.)
(c) $\alpha - \gamma = 1$ (d) $l + m = 0$

8. Three lines

$$L_1: \mathbf{r} = \lambda \hat{\mathbf{i}}, \lambda \in R,$$

$$L_2: \mathbf{r} = \hat{\mathbf{k}} + \mu \hat{\mathbf{j}}, \mu \in R$$

$$\text{and } L_3: \mathbf{r} = \hat{\mathbf{i}} + \hat{\mathbf{j}} + v \hat{\mathbf{k}}, v \in R$$

are given. For which point(s) Q on L_2 can we find a point P on L_1 and a point R on L_3 so that P, Q and R are collinear? (2019 Adv.)

- (a) $\hat{\mathbf{k}}$ (b) $\hat{\mathbf{k}} + \hat{\mathbf{j}}$
(c) $\hat{\mathbf{k}} + \frac{1}{2}\hat{\mathbf{j}}$ (d) $\hat{\mathbf{k}} - \frac{1}{2}\hat{\mathbf{j}}$

9. Let L_1 and L_2 denote the lines

$$\mathbf{r} = \hat{\mathbf{i}} + \lambda(-\hat{\mathbf{i}} + 2\hat{\mathbf{j}} + 2\hat{\mathbf{k}}), \lambda \in R$$

and $\mathbf{r} = \mu(2\hat{\mathbf{i}} - \hat{\mathbf{j}} + 2\hat{\mathbf{k}}), \mu \in R$

respectively. If L_3 is a line which is perpendicular to both L_1 and L_2 and cuts both of them, then which of the following options describe(s) L_3 ? (2019 Adv.)

(a) $\mathbf{r} = \frac{2}{9}(2\hat{\mathbf{i}} - \hat{\mathbf{j}} + 2\hat{\mathbf{k}}) + t(2\hat{\mathbf{i}} + 2\hat{\mathbf{j}} - \hat{\mathbf{k}}), t \in R$

(b) $\mathbf{r} = \frac{1}{3}(2\hat{\mathbf{i}} + \hat{\mathbf{k}}) + t(2\hat{\mathbf{i}} + 2\hat{\mathbf{j}} - \hat{\mathbf{k}}), t \in R$

(c) $\mathbf{r} = \frac{2}{9}(4\hat{\mathbf{i}} + \hat{\mathbf{j}} + \hat{\mathbf{k}}) + t(2\hat{\mathbf{i}} + 2\hat{\mathbf{j}} - \hat{\mathbf{k}}), t \in R$

(d) $\mathbf{r} = t(2\hat{\mathbf{i}} + 2\hat{\mathbf{j}} - \hat{\mathbf{k}}), t \in R$

10. From a point $P(\lambda, \lambda, \lambda)$, perpendiculars PQ and PR are drawn respectively on the lines $y = x, z = 1$ and $y = -x, z = -1$. If P is such that $\angle QPR$ is a right angle, then the possible value(s) of λ is (are) (2014 Adv.)

(a) $\sqrt{2}$ (b) 1 (c) -1 (d) $-\sqrt{2}$

11. Two lines $L_1: x = 5, \frac{y}{3-\alpha} = \frac{z}{-2}$ and

$L_2: x = \alpha, \frac{y}{-1} = \frac{z}{2-\alpha}$ are coplanar. Then, α can take value(s) (2013 Adv.)

(a) 1 (b) 2 (c) 3 (d) 4

12. A line l passing through the origin is perpendicular to the lines (2013 Adv.)

$$l_1: (3+t)\hat{\mathbf{i}} + (-1+2t)\hat{\mathbf{j}} + (4+2t)\hat{\mathbf{k}}, -\infty < t < \infty$$

$$l_2: (3+2s)\hat{\mathbf{i}} + (3+2s)\hat{\mathbf{j}} + (2+s)\hat{\mathbf{k}}, -\infty < s < \infty$$

Then, the coordinate(s) of the point(s) on l_2 at a distance of $\sqrt{17}$ from the point of intersection of l and l_1 is (are)

(a) $\left(\frac{7}{3}, \frac{7}{3}, \frac{5}{3}\right)$ (b) $(-1, -1, 0)$

(c) $(1, 1, 1)$ (d) $\left(\frac{7}{9}, \frac{7}{9}, \frac{8}{9}\right)$

Topic 3 Equation of a Plane

Objective Questions I (Only one correct option)

1. The mirror image of the point $(1, 2, 3)$ in a plane is $\left(-\frac{7}{3}, -\frac{4}{3}, -\frac{1}{3}\right)$. Which of the following points lies on this plane? (JEE Main 2020, 8 Jan, Shift III)
- (a) $(1, -1, 1)$ (b) $(-1, -1, 1)$
 (c) $(1, 1, 1)$ (d) $(-1, -1, -1)$
2. Let P be a plane passing through the points $(2, 1, 0)$, $(4, 1, 1)$ and $(5, 0, 1)$ and R be any point $(2, 1, 6)$. Then the image of R in the plane P is (JEE Main 2020, 7 Jan, Shift II)
- (a) $(6, 5, 2)$ (b) $(4, 3, 2)$
 (c) $(6, 5, -2)$ (d) $(3, 4, -2)$

3. The distance of the point $(1, -5, 9)$ from the plane $x - y + z = 5$ measured along the line $x = y = z$ is (2016 Main)

(a) $3\sqrt{10}$ (b) $10\sqrt{3}$ (c) $\frac{10}{\sqrt{3}}$ (d) $\frac{20}{3}$

4. The length of the perpendicular drawn from the point $(2, 1, 4)$ to the plane containing the lines $\mathbf{r} = (\hat{\mathbf{i}} + \hat{\mathbf{j}}) + \lambda(\hat{\mathbf{i}} + 2\hat{\mathbf{j}} - \hat{\mathbf{k}})$ and $\mathbf{r} = (\hat{\mathbf{i}} + \hat{\mathbf{j}}) + \mu(-\hat{\mathbf{i}} + \hat{\mathbf{j}} - 2\hat{\mathbf{k}})$ is (2019 Main, 12 April II)

(a) 3 (b) $\frac{1}{3}$ (c) $\sqrt{3}$ (d) $\frac{1}{\sqrt{3}}$

5. A plane which bisects the angle between the two given planes $2x - y + 2z - 4 = 0$ and $x + 2y + 2z - 2 = 0$, passes through the point (2019 Main, 12 April II)

(a) $(1, -4, 1)$ (b) $(1, 4, -1)$
 (c) $(2, 4, 1)$ (d) $(2, -4, 1)$

6. If the line $\frac{x-2}{3} = \frac{y+1}{2} = \frac{z-1}{-1}$ intersects the plane $2x + 3y - z + 13 = 0$ at a point P and the plane $3x + y + 4z = 16$ at a point Q , then PQ is equal to (2019 Main, 12 April I)

(a) 14 (b) $\sqrt{14}$ (c) $2\sqrt{7}$ (d) $2\sqrt{14}$

7. A perpendicular is drawn from a point on the line $\frac{x-1}{2} = \frac{y+1}{-1} = \frac{z}{1}$ to the plane $x + y + z = 3$ such that the foot of the perpendicular Q also lies on the plane $x - y + z = 3$. Then, the coordinates of Q are (2019 Main, 10 April II)

(a) $(-1, 0, 4)$ (b) $(4, 0, -1)$
 (c) $(2, 0, 1)$ (d) $(1, 0, 2)$

8. If the plane $2x - y + 2z + 3 = 0$ has the distances $\frac{1}{3}$ and $\frac{2}{3}$ units from the planes $4x - 2y + 4z + \lambda = 0$ and $2x - y + 2z + \mu = 0$, respectively, then the maximum value of $\lambda + \mu$ is equal to (2019 Main, 10 April II)

(a) 13 (b) 15 (c) 5 (d) 9

9. If $Q(0, -1, -3)$ is the image of the point P in the plane $3x - y + 4z = 2$ and R is the point $(3, -1, -2)$, then the area (in sq units) of ΔPQR is (2019 Main, 10 April I)

(a) $\frac{\sqrt{91}}{2}$ (b) $2\sqrt{13}$ (c) $\frac{\sqrt{91}}{4}$ (d) $\frac{\sqrt{65}}{2}$

10. Let P be the plane, which contains the line of intersection of the planes, $x + y + z - 6 = 0$ and $2x + 3y + z + 5 = 0$ and it is perpendicular to the XY -plane. Then, the distance of the point $(0, 0, 256)$ from P is equal to (2019 Main, 9 April II)

(a) $63\sqrt{5}$ (b) $205\sqrt{5}$ (c) $\frac{11}{\sqrt{5}}$ (d) $\frac{17}{\sqrt{5}}$

11. A plane passing through the points $(0, -1, 0)$ and $(0, 0, 1)$ and making an angle $\frac{\pi}{4}$ with the plane $y - z + 5 = 0$, also passes through the points (2019 Main, 9 April I)

(a) $(\sqrt{2}, 1, 4)$ (b) $(-\sqrt{2}, 1, -4)$
 (c) $(-\sqrt{2}, -1, -4)$ (d) $(\sqrt{2}, -1, 4)$

582 3D Geometry

12. If the line $\frac{x-1}{2} = \frac{y+1}{3} = \frac{z-2}{4}$ meets the plane, $x + 2y + 3z = 15$ at a point P , then the distance of P from the origin is
(2019 Main, 9 April I)
(a) $7/2$ (b) $9/2$ (c) $\sqrt{5}/2$ (d) $2\sqrt{5}$
13. The vector equation of the plane through the line of intersection of the planes $x + y + z = 1$ and $2x + 3y + 4z = 5$, which is perpendicular to the plane $x - y + z = 0$ is
(2019 Main, 8 April II)
(a) $\mathbf{r} \cdot (\hat{\mathbf{i}} - \hat{\mathbf{k}}) - 2 = 0$ (b) $\mathbf{r} \times (\hat{\mathbf{i}} + \hat{\mathbf{k}}) + 2 = 0$
(c) $\mathbf{r} \times (\hat{\mathbf{i}} - \hat{\mathbf{k}}) + 2 = 0$ (d) $\mathbf{r} \cdot (\hat{\mathbf{i}} - \hat{\mathbf{k}}) + 2 = 0$
14. The length of the perpendicular from the point $(2, -1, 4)$ on the straight line, $\frac{x+3}{10} = \frac{y-2}{-7} = \frac{z}{1}$ is
(2019 Main, 8 April I)
(a) greater than 3 but less than 4
(b) less than 2
(c) greater than 2 but less than 3
(d) greater than 4
15. The magnitude of the projection of the vector $2\hat{\mathbf{i}} + 3\hat{\mathbf{j}} + \hat{\mathbf{k}}$ on the vector perpendicular to the plane containing the vectors $\hat{\mathbf{i}} + \hat{\mathbf{j}} + \hat{\mathbf{k}}$ and $\hat{\mathbf{i}} + 2\hat{\mathbf{j}} + 3\hat{\mathbf{k}}$, is
(2019 Main, 8 April I)
(a) $\frac{\sqrt{3}}{2}$ (b) $\sqrt{6}$ (c) $3\sqrt{6}$ (d) $\frac{\sqrt{3}}{2}$
16. The equation of a plane containing the line of intersection of the planes $2x - y - 4 = 0$ and $y + 2z - 4 = 0$ and passing through the point $(1, 1, 0)$ is
(2019 Main, 8 April I)
(a) $x - 3y - 2z = -2$ (b) $2x - z = 2$
(c) $x - y - z = 0$ (d) $x + 3y + z = 4$
17. If an angle between the line, $\frac{x+1}{2} = \frac{y-2}{1} = \frac{z-3}{-2}$ and the plane, $x - 2y - kz = 3$ is $\cos^{-1}\left(\frac{2\sqrt{2}}{3}\right)$, then value of k is
(2019 Main, 12 Jan II)
(a) $\frac{\sqrt{5}}{3}$ (b) $\frac{\sqrt{3}}{5}$ (c) $-\frac{3}{5}$ (d) $-\frac{5}{3}$
18. Let S be the set of all real values of λ such that a plane passing through the points $(-\lambda^2, 1, 1)$, $(1, -\lambda^2, 1)$ and $(1, 1, -\lambda^2)$ also passes through the point $(-1, -1, 1)$. Then, S is equal to
(2019 Main, 12 Jan II)
(a) $\{\sqrt{3}, -\sqrt{3}\}$ (b) $\{3, -3\}$ (c) $\{1, -1\}$ (d) $\{\sqrt{3}\}$
19. The perpendicular distance from the origin to the plane containing the two lines, $\frac{x+2}{3} = \frac{y-2}{5} = \frac{z+5}{7}$ and $\frac{x-1}{1} = \frac{y-4}{4} = \frac{z+4}{7}$, is
(2019 Main, 12 Jan I)
(a) $11\sqrt{6}$ (b) $\frac{11}{\sqrt{6}}$ (c) 11 (d) $6\sqrt{11}$
20. Two lines $\frac{x-3}{1} = \frac{y+1}{3} = \frac{z-6}{-1}$ and $\frac{x+5}{7} = \frac{y-2}{-6} = \frac{z-3}{4}$ intersect at the point R . The reflection of R in the xy -plane has coordinates
(2019 Main, 11 Jan II)
(a) $(2, -4, -7)$ (b) $(2, -4, 7)$
(c) $(-2, 4, 7)$ (d) $(2, 4, 7)$
21. If the point $(2, \alpha, \beta)$ lies on the plane which passes through the points $(3, 4, 2)$ and $(7, 0, 6)$ and is perpendicular to the plane $2x - 5y = 15$, then $2\alpha - 3\beta$ is equal to
(2019 Main, 11 Jan II)
(a) 17 (b) 7 (c) 5 (d) 12
22. The plane containing the line $\frac{x-3}{2} = \frac{y+2}{-1} = \frac{z-1}{3}$ and also containing its projection on the plane $2x + 3y - z = 5$, contains which one of the following points?
(2019 Main, 11 Jan I)
(a) $(-2, 2, 2)$ (b) $(2, 2, 0)$ (c) $(2, 0, -2)$ (d) $(0, -2, 2)$
23. The direction ratios of normal to the plane through the points $(0, -1, 0)$ and $(0, 0, 1)$ and making an angle $\pi/4$ with the plane $y - z + 5 = 0$ are
(2019 Main, 11 Jan I)
(a) $2, -1, 1$ (b) $\sqrt{2}, 1, -1$
(c) $2, \sqrt{2}, -\sqrt{2}$ (d) $2\sqrt{3}, 1, -1$
24. The plane which bisects the line segment joining the points $(-3, -3, 4)$ and $(3, 7, 6)$ at right angles, passes through which one of the following points?
(2019 Main, 10 Jan II)
(a) $(4, -1, 7)$ (b) $(2, 1, 3)$ (c) $(-2, 3, 5)$ (d) $(4, 1, -2)$
25. On which of the following lines lies the point of intersection of the line, $\frac{x-4}{2} = \frac{y-5}{2} = \frac{z-3}{1}$ and the plane, $x + y + z = 2$?
(2019 Main, 10 Jan II)
(a) $\frac{x-4}{1} = \frac{y-5}{1} = \frac{z-1}{-1}$ (b) $\frac{x+3}{3} = \frac{4-y}{3} = \frac{z+1}{-2}$
(c) $\frac{x-2}{2} = \frac{y-3}{2} = \frac{z+3}{3}$ (d) $\frac{x-1}{1} = \frac{y-3}{2} = \frac{z+4}{-5}$
26. The plane passing through the point $(4, -1, 2)$ and parallel to the lines $\frac{x+2}{3} = \frac{y-2}{-1} = \frac{z+1}{2}$ and $\frac{x-2}{1} = \frac{y-3}{2} = \frac{z-4}{3}$ also passes through the point
(2019 Main, 10 Jan I)
(a) $(-1, -1, -1)$ (b) $(1, 1, -1)$
(c) $(1, 1, 1)$ (d) $(-1, -1, 1)$
27. Let A be a point on the line $\mathbf{r} = (1 - 3\mu)\hat{\mathbf{i}} + (\mu - 1)\hat{\mathbf{j}} + (2 + 5\mu)\hat{\mathbf{k}}$ and $B(3, 2, 6)$ be a point in the space. Then, the value of μ for which the vector \mathbf{AB} is parallel to the plane $x - 4y + 3z = 1$ is
(2019 Main, 10 Jan I)
(a) $\frac{1}{4}$ (b) $-\frac{1}{4}$ (c) $\frac{1}{8}$ (d) $\frac{1}{2}$
28. The equation of the plane containing the straight line $\frac{x}{2} = \frac{y}{3} = \frac{z}{4}$ and perpendicular to the plane containing the straight lines $\frac{x}{3} = \frac{y}{4} = \frac{z}{2}$ and $\frac{x}{4} = \frac{y}{2} = \frac{z}{3}$ is
(2019 Main, 9 Jan II)
(a) $5x + 2y - 4z = 0$ (b) $x + 2y - 2z = 0$
(c) $3x + 2y - 3z = 0$ (d) $x - 2y + z = 0$
29. The plane through the intersection of the planes $x + y + z = 1$ and $2x + 3y - z + 4 = 0$ and parallel to Y -axis also passes through the point
(2019 Main, 9 Jan I)
(a) $(3, 3, -1)$ (b) $(-3, 1, 1)$
(c) $(3, 2, 1)$ (d) $(-3, 0, -1)$

30. The equation of the line passing through $(-4, 3, 1)$, parallel to the plane $x + 2y - z - 5 = 0$ and intersecting the line $\frac{x+1}{-3} = \frac{y-3}{2} = \frac{z-2}{-1}$ is (2019 Main, 9 Jan I)
- (a) $\frac{x+4}{3} = \frac{y-3}{-1} = \frac{z-1}{1}$ (b) $\frac{x+4}{-1} = \frac{y-3}{1} = \frac{z-1}{1}$
 (c) $\frac{x+4}{1} = \frac{y-3}{1} = \frac{z-1}{3}$ (d) $\frac{x-4}{2} = \frac{y+3}{1} = \frac{z+1}{4}$
31. If L_1 is the line of intersection of the planes $2x - 2y + 3z - 2 = 0$, $x - y + z + 1 = 0$ and L_2 is the line of intersection of the planes $x + 2y - z - 3 = 0$, $3x - y + 2z - 1 = 0$, then the distance of the origin from the plane, containing the lines L_1 and L_2 is (2018 Main)
- (a) $\frac{1}{4\sqrt{2}}$ (b) $\frac{1}{3\sqrt{2}}$ (c) $\frac{1}{2\sqrt{2}}$ (d) $\frac{1}{\sqrt{2}}$
32. The length of the projection of the line segment joining the points $(5, -1, 4)$ and $(4, -1, 3)$ on the plane, $x + y + z = 7$ is (2018 Main)
- (a) $\frac{2}{\sqrt{3}}$ (b) $\frac{2}{3}$
 (c) $\frac{1}{3}$ (d) $\sqrt{\frac{2}{3}}$
33. Let \mathbf{u} be a vector coplanar with the vectors $\mathbf{a} = 2\hat{\mathbf{i}} + 3\hat{\mathbf{j}} - \hat{\mathbf{k}}$ and $\mathbf{b} = \hat{\mathbf{j}} + \hat{\mathbf{k}}$. If \mathbf{u} is perpendicular to \mathbf{a} and $\mathbf{u} \cdot \mathbf{b} = 24$, then $|\mathbf{u}|^2$ is equal to (2018 Main)
- (a) 336 (b) 315
 (c) 256 (d) 84
34. If the image of the point $P(1, -2, 3)$ in the plane $2x + 3y - 4z + 22 = 0$ measured parallel to the line $\frac{x}{1} = \frac{y}{4} = \frac{z}{5}$ is Q , then PQ is equal to (2017 Main)
- (a) $3\sqrt{5}$ (b) $2\sqrt{42}$
 (c) $\sqrt{42}$ (d) $6\sqrt{5}$
35. The distance of the point $(1, 3, -7)$ from the plane passing through the point $(1, -1, -1)$ having normal perpendicular to both the lines $\frac{x-1}{1} = \frac{y+2}{-2} = \frac{z-4}{3}$ and $\frac{x-2}{2} = \frac{y+1}{-1} = \frac{z+7}{-1}$, is (2017 Main)
- (a) $\frac{20}{\sqrt{74}}$ units (b) $\frac{10}{\sqrt{83}}$ units
 (c) $\frac{5}{\sqrt{83}}$ units (d) $\frac{10}{\sqrt{74}}$ units
36. The equation of the plane passing through the point $(1, 1, 1)$ and perpendicular to the planes $2x + y - 2z = 5$ and $3x - 6y - 2z = 7$ is (2017 Adv.)
- (a) $14x + 2y - 15z = 1$ (b) $-14x + 2y + 15z = 3$
 (c) $14x - 2y + 15z = 27$ (d) $14x + 2y + 15z = 31$
37. Let P be the image of the point $(3, 1, 7)$ with respect to the plane $x - y + z = 3$. Then, the equation of the plane passing through P and containing the straight line $\frac{x}{1} = \frac{y}{2} = \frac{z}{1}$ is (2016 Adv.)
- (a) $x + y - 3z = 0$ (b) $3x + z = 0$
 (c) $x - 4y + 7z = 0$ (d) $2x - y = 0$
38. The equation of the plane containing the lines $2x - 5y + z = 3$, $x + y + 4z = 5$ and parallel to the plane $x + 3y + 6z = 1$ is (2015 Main)
- (a) $2x + 6y + 12z = 13$ (b) $x + 3y + 6z = -7$
 (c) $x + 3y + 6z = 7$ (d) $2x + 6y + 12z = -13$
39. The distance of the point $(1, 0, 2)$ from the point of intersection of the line $\frac{x-2}{3} = \frac{y+1}{4} = \frac{z-2}{12}$ and the plane $x - y + z = 16$ is (2015 Main)
- (a) $2\sqrt{14}$ (b) 8 (c) $3\sqrt{21}$ (d) 13
40. The image of the line $\frac{x-1}{3} = \frac{y-3}{1} = \frac{z-4}{-5}$ in the plane $2x - y + z + 3 = 0$ is the line (2014 Main)
- (a) $\frac{x+3}{3} = \frac{y-5}{1} = \frac{z-2}{-5}$ (b) $\frac{x+3}{-3} = \frac{y-5}{-1} = \frac{z+2}{5}$
 (c) $\frac{x-3}{3} = \frac{y+5}{1} = \frac{z-2}{-5}$ (d) $\frac{x-3}{-3} = \frac{y+5}{-1} = \frac{z-2}{5}$
41. Perpendiculars are drawn from points on the line $\frac{x+2}{2} = \frac{y+1}{-1} = \frac{z}{3}$ to the plane $x + y + z = 3$. The feet of perpendiculars lie on the line (2013 Adv.)
- (a) $\frac{x}{5} = \frac{y-1}{8} = \frac{z-2}{-13}$ (b) $\frac{x}{2} = \frac{y-1}{3} = \frac{z-2}{-5}$
 (c) $\frac{x}{4} = \frac{y-1}{3} = \frac{z-2}{-7}$ (d) $\frac{x}{2} = \frac{y-1}{-7} = \frac{z-2}{5}$
42. Distance between two parallel planes $2x + y + 2z = 8$ and $4x + 2y + 4z + 5 = 0$ is (2013 Main)
- (a) $\frac{3}{2}$ (b) $\frac{5}{2}$ (c) $\frac{7}{2}$ (d) $\frac{9}{2}$
43. The equation of a plane passing through the line of intersection of the planes $x + 2y + 3z = 2$ and $x - y + z = 3$ and at a distance $2/\sqrt{3}$ from the point $(3, 1, -1)$ is (2012)
- (a) $5x - 11y + z = 17$ (b) $\sqrt{2}x + y = 3\sqrt{2} - 1$
 (c) $x + y + z = \sqrt{3}$ (d) $x - \sqrt{2}y = 1 - \sqrt{2}$
44. The point P is the intersection of the straight line joining the points $Q(2, 3, 5)$ and $R(1, -1, 4)$ with the plane $5x - 4y - z = 1$. If S is the foot of the perpendicular drawn from the point $T(2, 1, 4)$ to QR , then the length of the line segment PS is (2012)
- (a) $\frac{1}{\sqrt{2}}$ (b) $\sqrt{2}$ (c) 2 (d) $2\sqrt{2}$
45. If the distance of the point $P(1, -2, 1)$ from the plane $x + 2y - 2z = \alpha$, where $\alpha > 0$, is 5, then the foot of the perpendicular from P to the plane is (2010)
- (a) $\left(\frac{8}{3}, \frac{4}{3}, -\frac{7}{3}\right)$ (b) $\left(\frac{4}{3}, \frac{4}{3}, \frac{1}{3}\right)$
 (c) $\left(\frac{1}{3}, \frac{2}{3}, \frac{10}{3}\right)$ (d) $\left(\frac{2}{3}, \frac{1}{3}, \frac{5}{2}\right)$
46. Equation of the plane containing the straight line $\frac{x}{2} = \frac{y}{3} = \frac{z}{4}$ and perpendicular to the plane containing the straight lines $\frac{x}{3} = \frac{y}{4} = \frac{z}{2}$ and $\frac{x}{4} = \frac{y}{2} = \frac{z}{3}$ is (2010)
- (a) $x + 2y - 2z = 0$ (b) $3x + 2y - 2z = 0$
 (c) $x - 2y + z = 0$ (d) $5x + 2y - 4z = 0$

584 3D Geometry

47. A line with positive direction cosines passes through the point $P(2, -1, 2)$ and makes equal angles with the coordinate axes. The line meets the plane $2x + y + z = 9$ at point Q . The length of the line segment PQ equals (2009)
- (a) 1 (b) $\sqrt{2}$ (c) $\sqrt{3}$ (d) 2
48. If P is $(3, 2, 6)$ is a point in space and Q be a point on the line $\vec{r} = (\hat{i} - \hat{j} + 2\hat{k}) + \mu(-3\hat{i} + \hat{j} + 5\hat{k})$. Then, the value of μ for which the vector \vec{PQ} is parallel to the plane $x - 4y + 3z = 1$, is (2009)
- (a) $\frac{1}{4}$ (b) $-\frac{1}{4}$ (c) $\frac{1}{8}$ (d) $-\frac{1}{8}$
49. A plane passes through $(1, -2, 1)$ and is perpendicular to two planes $2x - 2y + z = 0$ and $x - y + 2z = 4$, then the distance of the plane from the point $(1, 2, 2)$ is (2006, 3M)
- (a) 0 (b) 1 (c) $\sqrt{2}$ (d) $2\sqrt{2}$
50. A variable plane $\frac{x}{a} + \frac{y}{b} + \frac{z}{c} = 1$ at a unit distance from origin cuts the coordinate axes at A, B and C . Centroid (x, y, z) satisfies the equation $\frac{1}{x^2} + \frac{1}{y^2} + \frac{1}{z^2} = K$. The value of K is (2005, 2M)
- (a) 9 (b) 3
(c) $1/9$ (d) $1/3$
51. The value of k such that $\frac{x-4}{1} = \frac{y-2}{1} = \frac{z-k}{2}$ lies in the plane $2x - 4y + z = 7$, is (2003, 1M)
- (a) 7 (b) -7
(c) No real value (d) 4

Objective Questions II

(One or more than one correct option)

52. Let $\alpha, \beta, \gamma, \delta$ be real numbers such that $\alpha^2 + \beta^2 + \gamma^2 \neq 0$ and $\alpha + \gamma = 1$. Suppose the point $(3, 2, -1)$ is the mirror image of the point $(1, 0, -1)$ with respect to the plane $\alpha x + \beta y + \gamma z = \delta$. Then which of the following statements is/are TRUE? (2020 Adv.)
- (a) $\alpha + \beta = 2$ (b) $\delta - \gamma = 3$
(c) $\delta + \beta = 4$ (d) $\alpha + \beta + \gamma = \delta$
53. Consider a pyramid $OPQRS$ located in the first octant ($x \geq 0, y \geq 0, z \geq 0$) with O as origin, and OP and OR along the X -axis and the Y -axis, respectively. The base $OPQR$ of the pyramid is a square with $OP = 3$. The point S is directly above the mid-point T of diagonal OQ such that $TS = 3$. Then, (2016 Adv.)
- (a) the acute angle between OQ and OS is $\frac{\pi}{3}$
(b) the equation of the plane containing the ΔOQS is $x - y = 0$
(c) the length of the perpendicular from P to the plane containing the ΔOQS is $\frac{3}{\sqrt{2}}$
(d) the perpendicular distance from O to the straight line containing RS is $\sqrt{\frac{15}{2}}$

54. In R^3 , consider the planes $P_1: y = 0$ and $P_2: x + z = 1$. Let P_3 be a plane, different from P_1 and P_2 , which passes through the intersection of P_1 and P_2 . If the distance of the point $(0, 1, 0)$ from P_3 is 1 and the distance of a point (α, β, γ) from P_3 is 2, then which of the following relation(s) is/are true? (2015 Adv.)
- (a) $2\alpha + \beta + 2\gamma + 2 = 0$ (b) $2\alpha - \beta + 2\gamma + 4 = 0$
(c) $2\alpha + \beta - 2\gamma - 10 = 0$ (d) $2\alpha - \beta + 2\gamma - 8 = 0$
55. In R^3 , let L be a straight line passing through the origin. Suppose that all the points on L are at a constant distance from the two planes $P_1: x + 2y - z + 1 = 0$ and $P_2: 2x - y + z - 1 = 0$. Let M be the locus of the foot of the perpendiculars drawn from the points on L to the plane P_1 . Which of the following point(s) lie(s) on M ? (2015 Adv.)
- (a) $(0, -\frac{5}{6}, -\frac{2}{3})$ (b) $(-\frac{1}{6}, -\frac{1}{3}, \frac{1}{6})$
(c) $(-\frac{5}{6}, 0, \frac{1}{6})$ (d) $(-\frac{1}{3}, 0, \frac{2}{3})$
56. Let $P_1: 2x + y - z = 3$ and $P_2: x + 2y + z = 2$ be two planes. Then, which of the following statement(s) is (are) TRUE? (2018 Adv.)
- (a) The line of intersection of P_1 and P_2 has direction ratios $1, 2, -1$
(b) The line $\frac{3x-4}{9} = \frac{1-3y}{9} = \frac{z}{3}$ is perpendicular to the line of intersection of P_1 and P_2
(c) The acute angle between P_1 and P_2 is 60°
(d) If P_3 is the plane passing through the point $(4, 2, -2)$ and perpendicular to the line of intersection of P_1 and P_2 , then the distance of the point $(2, 1, 1)$ from the plane P_3 is $\frac{2}{\sqrt{3}}$

57. If the straight lines $\frac{x-1}{2} = \frac{y+1}{K} = \frac{z}{2}$ and $\frac{x+1}{5} = \frac{y+1}{2} = \frac{z}{k}$ are coplanar, then the plane(s) containing these two lines is/are (2012)
- (a) $y + 2z = -1$ (b) $y + z = -1$
(c) $y - z = -1$ (d) $y - 2z = -1$

Integer & Numerical Answer Type Questions

58. Three lines are given by

$$\mathbf{r} = \lambda \hat{\mathbf{i}}, \lambda \in R$$

$$\mathbf{r} = \mu(\hat{\mathbf{i}} + \hat{\mathbf{j}}), \mu \in R$$

and $\mathbf{r} = \nu(\hat{\mathbf{i}} + \hat{\mathbf{j}} + \hat{\mathbf{k}}), \nu \in R$

Let the lines cut the plane $x + y + z = 1$ at the points A, B and C respectively. If the area of the triangle ABC is Δ then the value of $(6\Delta)^2$ equals (2019 Adv.)

59. Let P be a point in the first octant, whose image Q in the plane $x + y = 3$ (that is, the line segment PQ is perpendicular to the plane $x + y = 3$ and the mid-point of PQ lies in the plane $x + y = 3$) lies on the Z -axis. Let the distance of P from the X -axis be 5. If R is the image of P in the XY -plane, then the length of PR is (2018 Adv.)

Passage Based Problems

Read the following passage and answer the questions.
Consider the lines

$$L_1: \frac{x+1}{3} = \frac{y+2}{1} = \frac{z+1}{2}, L_2: \frac{x-2}{1} = \frac{y+2}{2} = \frac{z-3}{3}$$

(2008, 12M)

60. The distance of the point (1, 1, 1) from the plane passing through the point (-1, -2, -1) and whose normal is perpendicular to both the lines L_1 and L_2 , is
(a) $2\sqrt{75}$ unit (b) $7\sqrt{75}$ unit
(c) $13\sqrt{75}$ units (d) $23\sqrt{75}$ units
61. The shortest distance between L_1 and L_2 is
(a) 0 unit (b) $17\sqrt{3}$ units
(c) $41/5\sqrt{3}$ unit (d) $17/5\sqrt{3}$ units
62. The unit vector perpendicular to both L_1 and L_2 is
(a) $\frac{-\hat{i} + 7\hat{j} + 7\hat{k}}{\sqrt{99}}$ (b) $\frac{-\hat{i} - 7\hat{j} + 5\hat{k}}{5\sqrt{3}}$
(c) $\frac{-\hat{i} + 7\hat{j} + 5\hat{k}}{5\sqrt{3}}$ (d) $\frac{7\hat{i} - 7\hat{j} - \hat{k}}{\sqrt{99}}$

Assertion and Reason

For the following questions, choose the correct answer from the codes (a), (b), (c) and (d) defined as follows.

- (a) Statement I is true, Statement II is also true; Statement II is the correct explanation of Statement I
(b) Statement I is true, Statement II is also true; Statement II is not the correct explanation of Statement I
(c) Statement I is true; Statement II is false
(d) Statement I is false; Statement II is true
63. Consider three planes $P_1: x - y + z = 1$
 $P_2: x + y - z = -1$
and $P_3: x - 3y + 3z = 2$
Let L_1, L_2, L_3 be the lines of intersection of the planes P_2 and P_3, P_3 and P_1, P_1 and P_2 , respectively.
Statement I Atleast two of the lines L_1, L_2 and L_3 are non-parallel.
Statement II The three planes do not have a common point. (2008, 3M)
64. Consider the planes $3x - 6y - 2z = 15$ and $2x + y - 2z = 5$.
Statement I The parametric equations of the line of intersection of the given planes are $x = 3 + 14t$, $y = 1 + 2t$, $z = 15t$.
Statement II The vectors $14\hat{i} + 2\hat{j} + 15\hat{k}$ is parallel to the line of intersection of the given planes. (2007, 3M)

Match the Columns

Match the conditions/expressions in Column I with values statements in Column II.

65. Consider the lines $L_1: \frac{x-1}{2} = \frac{y}{-1} = \frac{z+3}{1}, L_2: \frac{x-4}{1} = \frac{y+3}{1} = \frac{z+3}{2}$ and the planes $P_1: 7x + y + 2z = 3, P_2: 3x + 5y - 6z = 4$. Let $ax + by + cz = d$ the equation of the plane passing through the point of intersection of lines L_1 and L_2 and perpendicular to planes P_1 and P_2 .
Match List I with List II and select the correct answer using the code given below the lists. (2013 Adv.)

	List I	List II
P.	$a =$	1. 13
Q.	$b =$	2. -3
R.	$c =$	3. 1
S.	$d =$	4. -2

Codes

	P	Q	R	S	P	Q	R	S	
(a)	3	2	4	1	(b)	1	3	4	2
(c)	3	2	1	4	(d)	2	4	1	3

66. Consider the following linear equations

$$ax + by + cz = 0, \quad bx + cy + az = 0, \quad cx + ay + bz = 0$$

(IIT 2007, 6M)

	Column I	Column II
A.	$a + b + c \neq 0$ and $a^2 + b^2 + c^2 = ab + bc + ca$	p. The equations represent planes meeting only at a single point
B.	$a + b + c = 0$ and $a^2 + b^2 + c^2 \neq ab + bc + ca$	q. The equations represent the line $x = y = z$
C.	$a + b + c \neq 0$ and $a^2 + b^2 + c^2 \neq ab + bc + ca$	r. The equations represent identical planes
D.	$a + b + c = 0$ and $a^2 + b^2 + c^2 = ab + bc + ca$	s. The equations represent the whole of the three-dimensional space

Analytical & Descriptive Questions

67. Find the equations of the plane containing the line $2x - y + z - 3 = 0, 3x + y + z = 5$ and at a distance of $\frac{1}{\sqrt{6}}$ from the point (2, 1, -1). (2005, 2M)
68. A plane is parallel to two lines whose direction ratios are (1, 0, -1) and (-1, 1, 0) and it contains the point (1, 1, 1). If it cuts coordinate axes at A, B, C. Then find the volume of the tetrahedron OABC. (2004, 2M)

586 3D Geometry

69. T is a parallelepiped in which A, B, C and D are vertices of one face and the face just above it has corresponding vertices A', B', C', D' . T is now compressed to S with face $ABCD$ remaining same and A', B', C', D' shifted to A'', B'', C'', D'' in S . The volume of parallelepiped S is reduced to 90 % of T . Prove that locus of A'' is a plane. (2004, 2M)
70. (i) Find the equation of the plane passing through the points $(2, 1, 0)$, $(5, 0, 1)$ and $(4, 1, 1)$.
 (ii) If P is the point $(2, 1, 6)$, then the point Q such that PQ is perpendicular to the plane in (a) and the mid-point of PQ lies on it. (2003, 4M)

Answers

Topic 1

1. (a)

Topic 2

1. (d) 2. (a) 3. (a) 4. (d)
 5. (c) 6. (b) 7. (a,b) 8. (c,d)
 9. (a,b,c) 10. (c) 11. (a, d) 12. (b, d)

Topic 3

1. (a) 2. (c)
 3. (b) 4. (c) 5. (d) 6. (d)
 7. (c) 8. (a) 9. (a) 10. (c)
 11. (a) 12. (b) 13. (d) 14. (a)
 15. (d) 16. (c) 17. (a) 18. (a)
 19. (b) 20. (a) 21. (b) 22. (c)
 23. (b, c) 24. (d) 25. (d) 26. (c)

27. (a) 28. (d) 29. (c) 30. (a)
 31. (b) 32. (d) 33. (a) 34. (b)
 35. (b) 36. (d) 37. (c) 38. (c)
 39. (d) 40. (a) 41. (d) 42. (c)
 43. (a) 44. (a) 45. (a) 46. (c)
 47. (c) 48. (a) 49. (d) 50. (a)
 51. (a) 52. (a,c) 53. (b, c, d) 54. (b, d)
 55. (a, b) 56. (c, d) 57. (b, c) 58. (0.75)
 59. (8) 60. (c) 61. (d) 62. (b)
 63. (d) 64. (d) 65. (a)
 66. $A \rightarrow r, B \rightarrow q; C \rightarrow p; D \rightarrow s$
 67. $2x - y + z - 3 = 0; 62x + 29y + 19z - 105 = 0$
 68. $\frac{9}{2}$ cu units 70. (i) $x + y - 2z = 3$ (ii) $Q(6, 5, -2)$

Hints & Solutions

Topic 1 Direction Cosines and Direction Ratios of a Line

1. We know that, angle between two lines is

$$\cos \theta = \frac{a_1 a_2 + b_1 b_2 + c_1 c_2}{\sqrt{a_1^2 + b_1^2 + c_1^2} \sqrt{a_2^2 + b_2^2 + c_2^2}}$$

$$l + m + n = 0$$

$$\Rightarrow l = -(m + n)$$

$$\Rightarrow (m + n)^2 = l^2$$

$$\Rightarrow m^2 + n^2 + 2mn = m^2 + n^2 \quad [\because l^2 = m^2 + n^2, \text{ given}]$$

$$\Rightarrow 2mn = 0$$

$$\text{When } m = 0 \Rightarrow l = -n$$

Hence, (l, m, n) is $(1, 0, -1)$.

$$\text{When } n = 0, \text{ then } l = -m$$

Hence, (l, m, n) is $(1, 0, -1)$.

$$\therefore \cos \theta = \frac{1 + 0 + 0}{\sqrt{2} \times \sqrt{2}} = \frac{1}{2}$$

$$\Rightarrow \theta = \frac{\pi}{3}$$

Topic 2 Straight Line in Space and Shortest Distance

1. Let point P whose position vector is $(-\hat{i} + 2\hat{j} + 6\hat{k})$ and a straight line passing through $Q(2, 3, -4)$ parallel to the vector $\mathbf{n} = 6\hat{i} + 3\hat{j} - 4\hat{k}$.

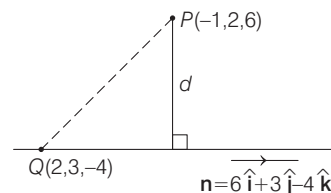

\therefore Required distance $d =$ Projection of line segment PQ perpendicular to vector \mathbf{n} .

$$= \frac{|\mathbf{PQ} \times \mathbf{n}|}{|\mathbf{n}|}$$

Now, $\mathbf{PQ} = 3\hat{i} + \hat{j} - 10\hat{k}$, so

$$\mathbf{PQ} \times \mathbf{n} = \begin{vmatrix} \hat{i} & \hat{j} & \hat{k} \\ 3 & 1 & -10 \\ 6 & 3 & -4 \end{vmatrix} = 26\hat{i} - 48\hat{j} + 3\hat{k}$$

So,
$$d = \frac{\sqrt{(26)^2 + (48)^2 + (3)^2}}{\sqrt{(6)^2 + (3)^2 + (4)^2}}$$

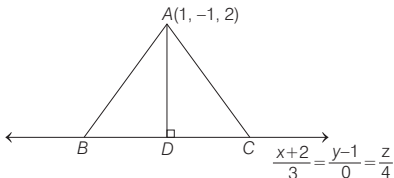

$$= \sqrt{\frac{676 + 2304 + 9}{36 + 9 + 16}} = \sqrt{\frac{2989}{61}} = \sqrt{49} = 7 \text{ units}$$

2. Given line is $\frac{x+2}{3} = \frac{y-1}{0} = \frac{z}{4}$

Vector along line is, $\mathbf{a} = 3\hat{\mathbf{i}} + 4\hat{\mathbf{k}}$

and vector joining the points $(1, -1, 2)$ to $(-2, 1, 0)$ is

$$\mathbf{b} = (1+2)\hat{\mathbf{i}} + (-1-1)\hat{\mathbf{j}} + (2-0)\hat{\mathbf{k}} \\ = 3\hat{\mathbf{j}} - 2\hat{\mathbf{j}} + 2\hat{\mathbf{k}}$$

and $|\mathbf{BC}| = 5$ units

Now, area of required $\triangle ABC$

$$= \frac{1}{2} |\mathbf{BC}| |\mathbf{b}| |\sin \theta| \quad \dots \text{(ii)}$$

[where θ is angle between vectors \mathbf{a} and \mathbf{b}]

$$\therefore |\mathbf{b}| \sin \theta = \frac{|\mathbf{a} \times \mathbf{b}|}{|\mathbf{a}|}$$

$$\therefore |\mathbf{a} \times \mathbf{b}| = \begin{vmatrix} \hat{\mathbf{i}} & \hat{\mathbf{j}} & \hat{\mathbf{k}} \\ 3 & 0 & 4 \\ 3 & -2 & 2 \end{vmatrix} = 8\hat{\mathbf{i}} + 6\hat{\mathbf{j}} - 6\hat{\mathbf{k}}$$

$$\Rightarrow |\mathbf{a} \times \mathbf{b}| = \sqrt{64 + 36 + 36} \\ = \sqrt{136} = 2\sqrt{34}$$

and $|\mathbf{a}| = \sqrt{9 + 16} = 5$

$$\therefore |\mathbf{b}| \sin \theta = \frac{2\sqrt{34}}{5}$$

On substituting these values in Eq. (i), we get

$$\text{Required area} = \frac{1}{2} \times 5 \times \frac{2\sqrt{34}}{5} = \sqrt{34} \text{ sq units}$$

Alternate Method

Given line is $\frac{x+2}{3} = \frac{y-1}{0} = \frac{z}{4} = \lambda$ (let) $\dots \text{(i)}$

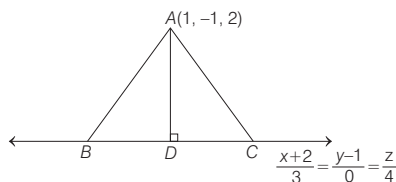

Since, point D lies on the line BC .

\therefore Coordinates of $D = (3\lambda - 2, 1, 4\lambda)$

Now, DR of $BC \Rightarrow a_1 = 3, b_1 = 0, c_1 = 4$

and DR of $AD \Rightarrow a_2 = 3\lambda - 3, b_2 = 2, c_2 = 4\lambda - 2$

Since, $AD \perp BC, a_1 a_2 + b_1 b_2 + c_1 c_2 = 0$

$$3 \times (3\lambda - 3) + 0(2) + 4(4\lambda - 2) = 0$$

$$\Rightarrow 9\lambda - 9 + 0 + 16\lambda - 8 = 0 \Rightarrow 25\lambda - 17 = 0$$

$$\Rightarrow \lambda = \frac{17}{25}$$

\therefore Coordinates of $D = \left(\frac{1}{25}, 1, \frac{68}{25}\right)$.

Now,
$$AD = \sqrt{\left(1 - \frac{1}{25}\right)^2 + (-1 - 1)^2 + \left(2 - \frac{68}{25}\right)^2}$$

$$= \sqrt{\left(\frac{24}{25}\right)^2 + (-2)^2 + \left(\frac{-18}{25}\right)^2}$$

$$= \sqrt{\frac{576}{625} + 4 + \frac{324}{625}} = \frac{2}{5} \sqrt{34}$$

$$\therefore \text{Area of } \triangle ABC = \frac{1}{2} BC \times AD = \frac{1}{2} \times 5 \times \frac{2}{5} \sqrt{34} \\ = \sqrt{34} \text{ sq units}$$

3. According to given information, we have the following figure.

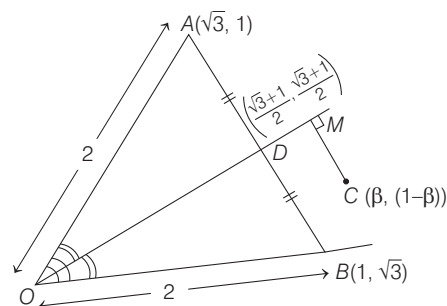

Clearly, angle bisector divides the sides AB in $OA : OB$, i.e., $2 : 2 = 1 : 1$ [using angle bisector theorem]

So, D is the mid-point of AB and hence coordinates of D

are $\left(\frac{\sqrt{3} + 1}{2}, \frac{\sqrt{3} + 1}{2}\right)$

Now, equation of bisector OD is

$$(y - 0) = \left(\frac{\frac{\sqrt{3} + 1}{2} - 0}{\frac{\sqrt{3} + 1}{2} - 0}\right) (x - 0) \Rightarrow y = x$$

$$\Rightarrow x - y = 0$$

According to the problem,

$$\frac{3}{\sqrt{2}} = CM = \left| \frac{\beta - (1 - \beta)}{\sqrt{2}} \right|$$

[Distance of a point $P(x_1, y_1)$ from the line

$$ax + by + c = 0 \text{ is } \left| \frac{ax_1 + by_1 + c}{\sqrt{a^2 + b^2}} \right|$$

$$\Rightarrow |2\beta - 1| = 3 \Rightarrow 2\beta = \pm 3 + 1$$

$$\Rightarrow 2\beta = 4, -2 \Rightarrow \beta = 2, -1$$

Sum of 2 and -1 is 1.

588 3D Geometry

4. Since, the line $\frac{x-3}{2} = \frac{y+2}{-1} = \frac{z+4}{3}$ lies in the plane

$lx + my - z = 9$, therefore we have $2l - m - 3 = 0$

[∵ normal will be perpendicular to the line]

$$\Rightarrow 2l - m = 3 \quad \dots(i)$$

and $3l - 2m + 4 = 9$

[∵ point $(3, -2, -4)$ lies on the plane]

$$\Rightarrow 3l - 2m = 5 \quad \dots(ii)$$

On solving Eqs. (i) and (ii), we get

$$l = 1 \text{ and } m = -1$$

$$\therefore 1^2 + m^2 = 2$$

5. Condition for two lines are coplanar.

$$\begin{vmatrix} x_1 - x_2 & y_1 - y_2 & z_1 - z_2 \\ l_1 & m_1 & n_1 \\ l_2 & m_2 & n_2 \end{vmatrix} = 0$$

where, (x_1, y_1, z_1) and (x_2, y_2, z_2) are the points lie on lines (i) and (ii) respectively and $\langle l_1, m_1, n_1 \rangle$ and $\langle l_2, m_2, n_2 \rangle$ are the direction cosines of the lines (i) and (ii), respectively.

$$\therefore \begin{vmatrix} 2-1 & 3-4 & 4-5 \\ 1 & 1 & -k \\ k & 2 & 1 \end{vmatrix} = 0 \Rightarrow \begin{vmatrix} 1 & -1 & -1 \\ 1 & 1 & -k \\ k & 2 & 1 \end{vmatrix} = 0$$

$$\Rightarrow 1(1+2k) + (1+k^2) - (2-k) = 0$$

$$\Rightarrow k^2 + 2k + k = 0$$

$$\Rightarrow k^2 + 3k = 0$$

$$\Rightarrow k = 0, -3$$

If 0 appears in the denominator, then the correct way of representing the equation of straight line is

$$\frac{x-2}{1} = \frac{y-3}{1}; z = 4$$

6. Since, the lines intersect, therefore they must have a point in common, i.e.

$$\frac{x-1}{2} = \frac{y+1}{3} = \frac{z-1}{4} = \lambda$$

and $\frac{x-3}{1} = \frac{y-k}{2} = \frac{z}{1} = \mu$

$$\Rightarrow x = 2\lambda + 1, y = 3\lambda - 1$$

$$z = 4\lambda + 1$$

and $x = \mu + 3, y = 2\mu + k, z = \mu$ are same.

$$\Rightarrow 2\lambda + 1 = \mu + 3$$

$$3\lambda - 1 = 2\mu + k \Rightarrow 4\lambda + 1 = \mu$$

On solving 1st and 3rd terms, we get,

$$\lambda = -\frac{3}{2} \text{ and } \mu = -5$$

$$\therefore k = 3\lambda - 2\mu - 1$$

$$\Rightarrow k = 3\left(-\frac{3}{2}\right) - 2(-5) - 1 = \frac{9}{2}$$

$$\therefore k = \frac{9}{2}$$

7. Equation of given straight lines

$$L_1: \frac{x-1}{1} = \frac{y}{-1} = \frac{z-1}{3}$$

and $L_2: \frac{x-1}{-3} = \frac{y}{-1} = \frac{z-1}{1}$

having vector form respectively, are

$$r = (\hat{i} + \hat{k}) + \lambda(\hat{i} - \hat{j} + 3\hat{k})$$

and $r = (\hat{i} + \hat{k}) + \mu(-3\hat{i} - \hat{j} + \hat{k})$

$$\therefore (\hat{i} - \hat{j} + 3\hat{k}) \cdot (-3\hat{i} - \hat{j} + \hat{k}) = -3 + 1 + 3 = 1 \text{ is positive,}$$

∴ Angle between supporting line vectors of lines L_1 and L_2 is acute, and point of intersection of given lines L_1 and L_2 is $(1, 0, 1)$.

Now, vector along the acute angle bisector of vectors $(\hat{i} - \hat{j} + 3\hat{k})$ and $(-3\hat{i} - \hat{j} + \hat{k})$ is $(-\hat{i} - \hat{j} + 2\hat{k})$ or $(\hat{i} + \hat{j} - 2\hat{k})$.

It is given that line

$$L: \frac{x-\alpha}{l} = \frac{y-1}{m} = \frac{z-\gamma}{-2}$$
 is the bisector of the acute angle

between the lines L_1 and L_2 , so

$$l = 1 \text{ and } m = 1$$

and $\frac{1-\alpha}{1} = \frac{0-1}{1} = \frac{1-\gamma}{-2}$

$$\Rightarrow \alpha = 2, \gamma = -1$$

$$\therefore \alpha - \gamma = 3, l + m = 2$$

8. **Key Idea** Points, A, B, C are collinear $\Rightarrow \mathbf{AB}, \mathbf{BC}$ are collinear vectors
 $\Rightarrow \mathbf{AB} = \lambda \mathbf{BC}$ for some non-zero scalar λ .

Given lines,

$$L_1: r = \lambda \hat{i}, \lambda \in R \quad \dots(i)$$

$$L_2: r = \mu \hat{j} + \hat{k}, \mu \in R \quad \dots(ii)$$

and $L_3: r = \hat{i} + \hat{j} + v\hat{k}, v \in R \quad \dots(iii)$

Now, let the point P on $L_1 = (\lambda, 0, 0)$

the point Q on $L_2 = (0, \mu, 1)$,

and the point R on $L_3 = (1, 1, v)$

For collinearity of points P, Q and R , there should be a non-zero scalar 'm', such that $\mathbf{PQ} = m \mathbf{PR}$

$$\Rightarrow (-\lambda \hat{i} + \mu \hat{j} + \hat{k}) = m [(1-\lambda)\hat{i} + \hat{j} + v\hat{k}]$$

$$\Rightarrow \frac{\lambda}{\lambda-1} = \frac{\mu}{1} = \frac{1}{v}$$

$$\Rightarrow v = \frac{1}{\mu} \text{ and } \lambda = \frac{\mu}{\mu-1} \text{ where, } \mu \neq 0 \text{ and } \mu \neq 1$$

$$\Rightarrow Q \neq \hat{k} \text{ and } Q \neq \hat{k} + \hat{j}$$

Hence, Q can not have coordinater $(0, 0, 1)$ and $(0, 1, 1)$

Hence, options (c) and (d) are correct.

9. Given lines

$$L_1: r = \hat{i} + \lambda(-\hat{i} + 2\hat{j} + 2\hat{k}), \lambda \in R \text{ and}$$

$$L_2: r = \mu(2\hat{i} - \hat{j} + 2\hat{k}), \mu \in R$$

and since line L_3 is perpendicular to both lines L_1 and L_2 .

Then a vector along L_3 will be,

$$\begin{vmatrix} \hat{i} & \hat{j} & \hat{k} \\ -1 & 2 & 2 \\ 2 & -1 & 2 \end{vmatrix} = \hat{i}(4+2) - \hat{j}(-2-4) + \hat{k}(1-4) \\ = 6\hat{i} + 6\hat{j} - 3\hat{k} = 3(2\hat{i} + 2\hat{j} - \hat{k}) \quad \dots(i)$$

Now, let a general point on line L_1 .

$P(1-\lambda, 2\lambda, 2\lambda)$ and on line L_2 .

as $Q(2\mu, -\mu, 2\mu)$ and let P and Q

are point of intersection of lines L_1, L_3 and L_2, L_3 , so direction ratio's of L_3

$$(2\mu + \lambda - 1, -\mu - 2\lambda, 2\mu - 2\lambda) \quad \dots(ii)$$

$$\text{Now, } \frac{2\mu + \lambda - 1}{2} = \frac{-\mu - 2\lambda}{2} = \frac{2\mu - 2\lambda}{-1} \text{ [from Eqs.(i) and (ii)]}$$

$$\Rightarrow \lambda = \frac{1}{9} \text{ and } \mu = \frac{2}{3}$$

$$\text{So, } P\left(\frac{8}{9}, \frac{2}{9}, \frac{2}{9}\right) \text{ and } Q\left(\frac{4}{9}, -\frac{2}{9}, \frac{4}{9}\right)$$

Now, we can take equation of line L_3 as

$\mathbf{r} = \mathbf{a} + t(2\hat{i} + 2\hat{j} - \hat{k})$, where \mathbf{a} is position vector of any point on line L_3 and possible vector of \mathbf{a} are

$$\left(\frac{8}{9}\hat{i} + \frac{2}{9}\hat{j} + \frac{2}{9}\hat{k}\right) \text{ or } \left(\frac{4}{9}\hat{i} - \frac{2}{9}\hat{j} + \frac{4}{9}\hat{k}\right) \text{ or } \left(\frac{2}{3}\hat{i} + \frac{1}{3}\hat{k}\right)$$

Hence, options (a), (b) and (c) are correct.

10. Key Idea

(i) Direction ratios of a line joining two points (x_1, y_1, z_1) and (x_2, y_2, z_2) are $x_2 - x_1, y_2 - y_1, z_2 - z_1$.

(ii) If the two lines with direction ratios $a_1, b_1, c_1; a_2, b_2, c_2$ are perpendicular, then $a_1 a_2 + b_1 b_2 + c_1 c_2 = 0$

Line L_1 is given by $y = x; z = 1$ can be expressed

$$L_1: \frac{x}{1} = \frac{y}{1} = \frac{z-1}{0} = \alpha \quad \text{[say]}$$

$$\Rightarrow x = \alpha, y = \alpha, z = 1$$

Let the coordinates of Q on L_1 be $(\alpha, \alpha, 1)$.

Line L_2 given by $y = -x, z = -1$ can be expressed as

$$L_2: \frac{x}{1} = \frac{y}{-1} = \frac{z+1}{0} = \beta \quad \text{[say]}$$

$$\Rightarrow x = \beta, y = -\beta, z = -1$$

Let the coordinates of R on L_2 be $(\beta, -\beta, -1)$.

Direction ratios of PQ are $\lambda - \alpha, \lambda - \alpha, \lambda - 1$.

Now, $PQ \perp L_1$

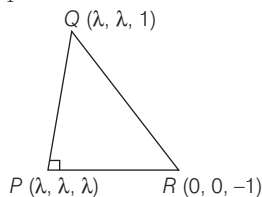

$$\therefore 1(\lambda - \alpha) + 1 \cdot (\lambda - \alpha) + 0 \cdot (\lambda - 1) = 0 \Rightarrow \lambda = \alpha$$

Hence, $Q(\lambda, \lambda, 1)$

Direction ratios of PR are $\lambda - \beta, \lambda + \beta, \lambda + 1$.

Now, $PR \perp L_2$

$$\therefore 1(\lambda - \beta) + (-1)(\lambda + \beta) + 0(\lambda + 1) = 0 \\ \lambda - \beta - \lambda - \beta = 0 \\ \Rightarrow \beta = 0$$

Hence, $R(0, 0, -1)$

Now, as $\angle QPR = 90^\circ$

[as $a_1 a_2 + b_1 b_2 + c_1 c_2 = 0$, if two lines with DR's $a_1, b_1, c_1; a_2, b_2, c_2$ are perpendicular]

$$\therefore (\lambda - \lambda)(\lambda - 0) + (\lambda - \lambda)(\lambda - 0) + (\lambda - 1)(\lambda + 1) = 0$$

$$\Rightarrow (\lambda - 1)(\lambda + 1) = 0$$

$$\Rightarrow \lambda = 1$$

$$\text{or } \lambda = -1$$

$\lambda = 1$, rejected as P and Q are different points.

$$\Rightarrow \lambda = -1$$

11. Key Idea If two straight lines are coplanar,

$$\text{i.e. } \frac{x - x_1}{a_1} = \frac{y - y_1}{b_1} = \frac{z - z_1}{c_1}$$

$$\text{and } \frac{x - x_2}{a_2} = \frac{y - y_2}{b_2} = \frac{z - z_2}{c_2} \text{ are coplanar}$$

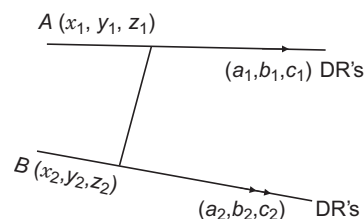

Then, $(x_2 - x_1, y_2 - y_1, z_2 - z_1), (a_1, b_1, c_1)$ and (a_2, b_2, c_2) are coplanar,

$$\text{i.e. } \begin{vmatrix} x_2 - x_1 & y_2 - y_1 & z_2 - z_1 \\ a_1 & b_1 & c_1 \\ a_2 & b_2 & c_2 \end{vmatrix} = 0$$

Here,

$$x = 5, \frac{y}{3 - \alpha} = \frac{z}{-2}$$

$$\Rightarrow \frac{x - 5}{0} = \frac{y - 0}{-(\alpha - 3)} = \frac{z - 0}{-2} \quad \dots(i)$$

and

$$x = \alpha, \frac{y}{-1} = \frac{z}{2 - \alpha}$$

$$\Rightarrow \frac{x - \alpha}{0} = \frac{y - 0}{-1} = \frac{z - 0}{2 - \alpha} \quad \dots(ii)$$

$$\Rightarrow \begin{vmatrix} 5 - \alpha & 0 & 0 \\ 0 & 3 - \alpha & -2 \\ 0 & -1 & 2 - \alpha \end{vmatrix} = 0$$

$$\Rightarrow (5 - \alpha) [(3 - \alpha)(2 - \alpha) - 2] = 0$$

$$\Rightarrow (5 - \alpha) [\alpha^2 - 5\alpha + 4] = 0$$

$$\Rightarrow (5 - \alpha) (\alpha - 1) (\alpha - 4) = 0$$

$$\therefore \alpha = 1, 4, 5$$

590 3D Geometry

12. Key Idea Equation of straight line is $l: \frac{x-x_1}{a} = \frac{y-y_1}{b} = \frac{z-z_1}{c}$

Since, l is perpendicular to l_1 and l_2 .

So, its DR's are cross-product of l_1 and l_2 .

Now, to find a point on l_2 whose distance is given, assume a point and find its distance to obtain point.

$$\text{Let } l: \frac{x-0}{a} = \frac{y-0}{b} = \frac{z-0}{c}$$

which is perpendicular to

$$l_1: (3\hat{i} - \hat{j} + 4\hat{k}) + t(\hat{i} + 2\hat{j} + 2\hat{k})$$

$$l_2: (3\hat{i} + 3\hat{j} + 2\hat{k}) + s(2\hat{i} + 2\hat{j} + \hat{k})$$

$$\therefore \text{DR's of } l \text{ is } \begin{vmatrix} \hat{i} & \hat{j} & \hat{k} \\ 1 & 2 & 2 \\ 2 & 2 & 1 \end{vmatrix} = -2\hat{i} + 3\hat{j} - 2\hat{k}$$

$$l: \frac{x}{-2} = \frac{y}{3} = \frac{z}{-2} = k_1, k_2$$

Now, $A(-2k_1, 3k_1, -2k_1)$ and $B(-2k_2, 3k_2, -2k_2)$.

Since, A lies on l_1 .

$$\therefore (-2k_1)\hat{i} + (3k_1)\hat{j} - (2k_1)\hat{k} = (3+t)\hat{i} + (-1+2t)\hat{j} + (4+2t)\hat{k}$$

$$\Rightarrow 3+t = -2k_1, -1+2t = 3k_1, 4+2t = -2k_1$$

$$\therefore k_1 = -1 \Rightarrow A(2, -3, 2)$$

Let any point on l_2 $(3+2s, 3+2s, 2+s)$

$$\sqrt{(2-3-2s)^2 + (-3-3-2s)^2 + (2-2-s)^2} = \sqrt{17}$$

$$\Rightarrow 9s^2 + 28s + 37 = 17$$

$$\Rightarrow 9s^2 + 28s + 20 = 0$$

$$\Rightarrow 9s^2 + 18s + 10s + 20 = 0$$

$$\Rightarrow (9s+10)(s+2) = 0$$

$$\therefore s = -2, \frac{-10}{9}$$

Hence, $(-1, -1, 0)$ and $(\frac{7}{9}, \frac{7}{9}, \frac{8}{9})$ are required points.

Topic 3 Equation of a Plane

1. Since, the mirror image of the point $A(1, 2, 3)$ in a plane is $B(-\frac{7}{3}, -\frac{4}{3}, -\frac{1}{3})$, then mid-point of AB lies in the plane and dr 's of line AB is the dr 's, of normal to the plane.

$$\text{Now, mid-point of } AB \text{ is } P\left(\frac{1-\frac{7}{3}}{2}, \frac{2-\frac{4}{3}}{2}, \frac{3-\frac{1}{3}}{2}\right)$$

$$P\left(-\frac{2}{3}, \frac{1}{3}, \frac{4}{3}\right)$$

and dr 's of line AB is $(1 + \frac{7}{3}, 2 + \frac{4}{3}, 3 + \frac{1}{3})$

$$\sim \left(\frac{10}{3}, \frac{10}{3}, \frac{10}{3}\right) \sim (1, 1, 1)$$

\therefore Equation of the plane is

$$1\left(x + \frac{2}{3}\right) + 1\left(y - \frac{1}{3}\right) + 1\left(z - \frac{4}{3}\right) = 0$$

$$\Rightarrow x + y + z = 1 \quad \dots(i)$$

From the option the point $(1, -1, 1)$ satisfy the plane $x + y + z = 1$.

Hence, option (a) is correct.

2. Equation of plane passing through the points $(2, 1, 0)$,

$(4, 1, 1)$ and $(5, 0, 1)$ is

$$\begin{vmatrix} x-2 & y-1 & z-0 \\ 4-2 & 1-1 & 1-0 \\ 5-2 & 0-1 & 1-0 \end{vmatrix} = 0 \Rightarrow \begin{vmatrix} x-2 & y-1 & z \\ 2 & 0 & 1 \\ 3 & -1 & 1 \end{vmatrix} = 0$$

$$\Rightarrow (x-2)(0+1) - (y-1)(2-3) + z(-2-0) = 0$$

$$\Rightarrow x-2 + y-1 - 2z = 0$$

$$\Rightarrow x + y - 2z - 3 = 0 \quad \dots(ii)$$

Now, let the image of point $R(2, 1, 6)$ w.r.t. plane (1) is (x_1, y_1, z_1) , then

$$\frac{x_1-2}{1} = \frac{y_1-1}{1} = \frac{z_1-6}{-2}$$

$$= -2 \left(\frac{2+1-12-3}{1^2+1^2+(-2)^2} \right)$$

$$\Rightarrow \frac{x_1-2}{1} = \frac{y_1-1}{1} = \frac{z_1-6}{-2} = \frac{2 \times 12}{6} = 4$$

$$\Rightarrow x_1 = 6, y_1 = 5, z_1 = -2$$

\therefore Image of point $R(2, 1, 6)$ w.r.t. plane (1) is $(6, 5, -2)$.

3. Equation of line passing through the point $(1, -5, 9)$ and parallel to $x = y = z$ is

$$\frac{x-1}{1} = \frac{y+5}{1} = \frac{z-9}{1} = \lambda \quad (\text{say})$$

Thus, any point on this line is of the form $(\lambda + 1, \lambda - 5, \lambda + 9)$.

Now, if $P(\lambda + 1, \lambda - 5, \lambda + 9)$ is the point of intersection of line and plane, then

$$(\lambda + 1) - (\lambda - 5) + \lambda + 9 = 5$$

$$\Rightarrow \lambda + 15 = 5 \Rightarrow \lambda = -10$$

\therefore Coordinates of point P are $(-9, -15, -1)$.

Hence, required distance

$$= \sqrt{(1+9)^2 + (-5+15)^2 + (9+1)^2} = \sqrt{10^2 + 10^2 + 10^2} = 10\sqrt{3}$$

4. **Key Idea** \therefore Length of the perpendicular drawn from point (x_1, y_1, z_1) to the plane $ax + by + cz + d = 0$ is

$$d_1 = \frac{|ax_1 + by_1 + cz_1 + d|}{\sqrt{a^2 + b^2 + c^2}}$$

Given line vectors

$$\mathbf{r} = (\hat{i} + \hat{j}) + \lambda (\hat{i} + 2\hat{j} - \hat{k}) \quad \dots(i)$$

$$\mathbf{r} = (\hat{i} + \hat{j}) + \mu (-\hat{i} + \hat{j} - 2\hat{k}) \quad \dots(ii)$$

Now, a vector perpendicular to the given vectors (i) and (ii) is

$$\begin{aligned} \mathbf{n} &= \begin{vmatrix} \hat{\mathbf{i}} & \hat{\mathbf{j}} & \hat{\mathbf{k}} \\ 1 & 2 & -1 \\ -1 & 1 & -2 \end{vmatrix} \\ &= \hat{\mathbf{i}}(-4+1) - \hat{\mathbf{j}}(-2-1) + \hat{\mathbf{k}}(1+2) \\ &= -3\hat{\mathbf{i}} + 3\hat{\mathbf{j}} + 3\hat{\mathbf{k}} \end{aligned}$$

∴ The equation of plane containing given vectors (i) and (ii) is

$$\begin{aligned} -3(x-1) + 3(y-1) + 3(z-0) &= 0 \\ \Rightarrow -3x + 3y + 3z &= 0 \\ \Rightarrow x - y - z &= 0 \quad \dots(\text{iii}) \end{aligned}$$

Now, the length of perpendicular drawn from the point (2, 1, 4) to the plane $x - y - z = 0$, is

$$d_1 = \frac{|2-1-4|}{\sqrt{1+1+1}} = \frac{3}{\sqrt{3}} = \sqrt{3}$$

5. Key Idea Equation of planes bisecting the angles between the planes $a_1x + b_1y + c_1z + d_1 = 0$ and $a_2x + b_2y + c_2z + d_2 = 0$, are $\frac{a_1x + b_1y + c_1z + d_1}{\sqrt{a_1^2 + b_1^2 + c_1^2}} = \pm \frac{a_2x + b_2y + c_2z + d_2}{\sqrt{a_2^2 + b_2^2 + c_2^2}}$

Equation of given planes are

$$2x - y + 2z - 4 = 0 \quad \dots(\text{i})$$

and $x + 2y + 2z - 2 = 0 \quad \dots(\text{ii})$

Now, equation of planes bisecting the angles between the planes (i) and (ii) are

$$\frac{2x - y + 2z - 4}{\sqrt{4 + 1 + 4}} = \pm \frac{x + 2y + 2z - 2}{\sqrt{1 + 4 + 4}}$$

$$\Rightarrow 2x - y + 2z - 4 = \pm (x + 2y + 2z - 2)$$

On taking (+ve) sign, we get a plane $x - 3y = 2 \quad \dots(\text{iii})$

On taking (-ve) sign, we get a plane $3x + y + 4z = 6 \quad \dots(\text{iv})$

Now from the given options, the point (2, -4, 1) satisfy the plane of angle bisector $3x + y + 4z = 6$

6. Equation of given line is $\frac{x-2}{3} = \frac{y+1}{2} = \frac{z-1}{-1} = r \quad (\text{let}) \dots(\text{i})$

Now, coordinates of a general point over given line is $R(3r + 2, 2r - 1, -r + 1)$

Let the coordinates of point P are $(3r_1 + 2, 2r_1 - 1, r_1 + 1)$ and Q are $(3r_2 + 2, 2r_2 - 1, -r_2 + 1)$.

Since, P is the point of intersection of line (i) and the plane $2x + 3y - z + 13 = 0$, so

$$2(3r_1 + 2) + 3(2r_1 - 1) - (r_1 + 1) + 13 = 0$$

$$\Rightarrow 6r_1 + 4 + 6r_1 - 3 + r_1 - 1 + 13 = 0$$

$$\Rightarrow 13r_1 + 13 = 0 \Rightarrow r_1 = -1$$

So, point $P(-1, -3, 2)$

And, similarly for point 'Q', we get

$$3(3r_2 + 2) + (2r_2 - 1) + 4(-r_2 + 1) = 16$$

$$\Rightarrow 7r_2 = 7 \Rightarrow r_2 = 1$$

So, point is $Q(5, 1, 0)$

Now, $PQ = \sqrt{(5+1)^2 + (1+3)^2 + 2^2}$

$$= \sqrt{36 + 16 + 4}$$

$$= \sqrt{56} = 2\sqrt{14}$$

7. Key Idea Use the foot of perpendicular $Q(x_2, y_2, z_2)$ drawn from point $P(x_1, y_1, z_1)$ to the plane $ax + by + cz + d = 0$, is given by

$$\frac{x_2 - x_1}{a} = \frac{y_2 - y_1}{b} = \frac{z_2 - z_1}{c} = -\frac{ax_1 + by_1 + cz_1 + d}{a^2 + b^2 + c^2}$$

Let a general point on the given line

$$\frac{x-1}{2} = \frac{y+1}{-1} = \frac{z}{1} = r \quad (\text{say})$$

is $P(2r + 1, -1 - r, r)$.

Now, let foot of perpendicular $Q(x_1, y_1, z_1)$ to be drawn from point $P(2r + 1, -1 - r, r)$ to the plane $x + y + z = 3$, then

$$\frac{x_1 - 2r - 1}{1} = \frac{y_1 + 1 + r}{1} = \frac{z_1 - r}{1}$$

$$= -\left(\frac{2r + 1 - 1 - r + r - 3}{1 + 1 + 1}\right)$$

$$\Rightarrow x_1 - 2r - 1 = y_1 + r + 1 = z_1 - r = \frac{1}{3}(3 - 2r) = 1 - \frac{2}{3}r$$

$$\Rightarrow x_1 = 2 + \frac{4r}{3}, y_1 = -\frac{5r}{3} \text{ and } z_1 = 1 + \frac{r}{3}$$

So, point $Q \equiv \left(2 + \frac{4r}{3}, -\frac{5r}{3}, 1 + \frac{r}{3}\right)$, lies on the plane $x - y + z = 3$ also.

So, $2 + \frac{4r}{3} + \frac{5r}{3} + 1 + \frac{r}{3} = 3 \Rightarrow r = 0$

Therefore, the coordinates of point Q are (2, 0, 1).

8. Equation of given planes are $2x - y + 2z + 3 = 0 \quad \dots(\text{i})$

$$4x - 2y + 4z + \lambda = 0 \quad \dots(\text{ii})$$

and $2x - y + 2z + \mu = 0 \quad \dots(\text{iii})$

∴ Distance between two parallel planes

$$ax + by + cz + d_1 = 0$$

and $ax + by + cz + d_2 = 0$ is

$$\text{distance} = \frac{|d_1 - d_2|}{\sqrt{a^2 + b^2 + c^2}}$$

∴ Distance between planes (i) and (ii) is

$$\frac{|\lambda - 2(3)|}{\sqrt{16 + 4 + 16}} = \frac{1}{3} \quad [\text{given}]$$

$$\Rightarrow |\lambda - 6| = 2 \Rightarrow \lambda - 6 = \pm 2 \Rightarrow \lambda = 8 \text{ or } 4$$

592 3D Geometry

and distance between planes (i) and (iii) is

$$\frac{|\mu - 3|}{\sqrt{4 + 1 + 4}} = \frac{2}{3} \quad \text{[given]}$$

$$\Rightarrow |\mu - 3| = 2$$

$$\Rightarrow \mu - 3 = \pm 2 \Rightarrow \mu = 5 \text{ or } 1$$

So, maximum value of $(\lambda + \mu)$ at $\lambda = 8$ and $\mu = 5$ and it is equal to 13.

9. Given, equation of plane $3x - y + 4z = 2$... (i) and the point $Q(0, -1, -3)$ is the image of point P in the plane (i), so point P is also image of point Q w.r.t. plane (i).

Let the coordinates of point P is (x_1, y_1, z_1) , then

$$\begin{aligned} \frac{x_1 - 0}{3} &= \frac{y_1 + 1}{-1} = \frac{z_1 + 3}{4} \\ &= -2 \frac{[3(0) - 1(-1) + 4(-3) - 2]}{3^2 + (-1)^2 + 4^2} \end{aligned}$$

[∴ image of the point (x_1, y_1, z_1) in the plane $ax + by + cz + d = 0$ is (x, y, z) , where

$$\frac{x - x_1}{a} = \frac{y - y_1}{b} = \frac{z - z_1}{c} = \frac{-2(ax_1 + by_1 + cz_1 + d)}{a^2 + b^2 + c^2}]$$

$$\Rightarrow \frac{x_1 - 0}{3} = \frac{y_1 + 1}{-1} = \frac{z_1 + 3}{4} = 2 \frac{(1 - 12 - 2)}{26} = \frac{26}{26} = 1$$

$$\Rightarrow P(x_1, y_1, z_1) = (3, -2, 1)$$

Now, area of ΔPQR , where point $R(3, -1, -2)$

$$= \frac{1}{2} \left| \vec{PQ} \times \vec{PR} \right| = \frac{1}{2} \left| (-3\hat{i} + \hat{j} - 4\hat{k}) \times (0\hat{i} + \hat{j} - 3\hat{k}) \right|$$

$$= \frac{1}{2} \left| \begin{vmatrix} \hat{i} & \hat{j} & \hat{k} \\ -3 & 1 & -4 \\ 0 & 1 & -3 \end{vmatrix} \right| = \frac{1}{2} \left| \hat{i} - 9\hat{j} - 3\hat{k} \right|$$

$$= \frac{1}{2} \sqrt{1 + 81 + 9} = \frac{\sqrt{91}}{2} \text{ sq units}$$

10. Equation of plane, which contains the line of intersection of the planes

$$x + y + z - 6 = 0 \text{ and } 2x + 3y + z + 5 = 0, \text{ is}$$

$$(x + y + z - 6) + \lambda(2x + 3y + z + 5) = 0$$

$$\Rightarrow (1 + 2\lambda)x + (1 + 3\lambda)y + (1 + \lambda)z + (5\lambda - 6) = 0 \quad \dots(i)$$

∴ The plane (i) is perpendicular to XY -plane (as DR's of normal to XY -plane is $(0, 0, 1)$).

$$\therefore 0(1 + 2\lambda) + 0(1 + 3\lambda) + 1(1 + \lambda) = 0$$

$$\Rightarrow \lambda = -1$$

On substituting $\lambda = -1$ in Eq. (i),

we get

$$-x - 2y - 11 = 0$$

$$\Rightarrow x + 2y + 11 = 0 \quad \dots(ii)$$

which is the required equation of the plane.

Now, the distance of the point $(0, 0, 256)$ from plane P is

$$\frac{0 + 0 + 11}{\sqrt{1 + 4}} = \frac{11}{\sqrt{5}}$$

[∴ distance of (x_1, y_1, z_1) from the plane

$$ax + by + cz - d = 0, \text{ is } \left| \frac{ax_1 + by_1 + cz_1 - d}{\sqrt{a^2 + b^2 + c^2}} \right|$$

11. Let the equation of plane is

$$ax + by + cz = d \quad \dots(i)$$

Since plane (i) passes through the points $(0, -1, 0)$ and $(0, 0, 1)$, then $-b = d$ and $c = d$

$$\therefore \text{Equation of plane becomes } ax - dy + dz = d \quad \dots(ii)$$

∴ The plane (ii) makes an angle of $\frac{\pi}{4}$ with the plane

$$y - z + 5 = 0.$$

$$\cos \frac{\pi}{4} = \left| \frac{-d - d}{\sqrt{a^2 + d^2 + d^2} \sqrt{1 + 1}} \right|$$

[∴ The angle between the two planes

$$a_1x + b_1y + c_1z + d = 0 \text{ and } a_2x + b_2y + c_2z + d = 0 \text{ is}$$

$$\cos \theta = \left| \frac{a_1 a_2 + b_1 b_2 + c_1 c_2}{\sqrt{a_1^2 + b_1^2 + c_1^2} \sqrt{a_2^2 + b_2^2 + c_2^2}} \right|$$

$$\Rightarrow \frac{1}{\sqrt{2}} = \frac{|-2d|}{\sqrt{a^2 + 2d^2} \sqrt{2}} \Rightarrow \sqrt{a^2 + 2d^2} = |-d|$$

$$\Rightarrow a^2 + 2d^2 = 4d^2 \quad \text{[squaring both sides]}$$

$$\Rightarrow a^2 = 2d^2 \Rightarrow a = \pm \sqrt{2}d$$

So, the Eq. (ii) becomes

$$\pm \sqrt{2}x - y + z = 1 \quad \dots(i)$$

Now, from options $(\sqrt{2}, 1, 4)$ satisfy the plane

$$-\sqrt{2}x - y + z = 1$$

12. Equation of given plane is

$$x + 2y + 3z = 15 \quad \dots(i)$$

$$\text{and line is, } \frac{x-1}{2} = \frac{y+1}{3} = \frac{z-2}{4} = r \text{ (let)} \quad \dots(ii)$$

So, the coordinates of any point on line (ii) is

$$P(1 + 2r, -1 + 3r, 2 + 4r).$$

∴ Point P is intersecting point of plane (i) and line (ii)

$$\therefore (1 + 2r) + 2(-1 + 3r) + 3(2 + 4r) = 15$$

$$\Rightarrow 1 + 2r - 2 + 6r + 6 + 12r = 15 \Rightarrow 20r = 10$$

$$\Rightarrow r = \frac{1}{2}$$

$$\therefore \text{Coordinates of } P = \left(1 + 1, -1 + \frac{3}{2}, 2 + 2\right) = \left(2, \frac{1}{2}, 4\right)$$

Now, distance of the point P from the origin

$$= \sqrt{4 + \frac{1}{4} + 16} = \sqrt{20 + \frac{1}{4}} = \sqrt{\frac{81}{4}} = \frac{9}{2} \text{ units}$$

13. Since, equation of planes passes through the line of intersection of the planes

$$x + y + z = 1$$

and $2x + 3y + 4z = 5$, is

$$(x + y + z - 1) + \lambda(2x + 3y + 4z - 5) = 0$$

$$\Rightarrow (1 + 2\lambda)x + (1 + 3\lambda)y + (1 + 4\lambda)z - (1 + 5\lambda) = 0 \quad \dots(i)$$

∴ The plane (i) is perpendicular to the plane

$$x - y + z = 0.$$

$$\therefore (1 + 2\lambda) - (1 + 3\lambda) + (1 + 4\lambda) = 0$$

[∴ if plane $a_1x + b_1y + c_1z + d_1 = 0$ is perpendicular to plane $a_2x + b_2y + c_2z + d_2 = 0$, then $a_1a_2 + b_1b_2 + c_1c_2 = 0$]

$$\begin{aligned} \Rightarrow 3\lambda + 1 &= 0 \\ \Rightarrow \lambda &= -\frac{1}{3} \end{aligned} \quad \dots(ii)$$

So, the equation of required plane, is

$$\left(1 - \frac{2}{3}\right)x + \left(1 - \frac{3}{3}\right)y + \left(1 - \frac{4}{3}\right)z - \left(1 - \frac{5}{3}\right) = 0$$

$$\Rightarrow \frac{1}{3}x - \frac{1}{3}z + \frac{2}{3} = 0 \Rightarrow x - z + 2 = 0$$

Now, vector form, is $\mathbf{r} \cdot (\hat{\mathbf{i}} - \hat{\mathbf{k}}) + 2 = 0$

14. Equation of given line is

$$\frac{x+3}{10} = \frac{y-2}{-7} = \frac{z}{1} = r \text{ (let)} \quad \dots(i)$$

Coordinates of a point on line (i) is $A(10r-3, -7r+2, r)$

Now, let the line joining the points $P(2, -1, 4)$ and $A(10r-3, -7r+2, r)$ is perpendicular to line (i). Then,

$$\mathbf{PA} \cdot (10\hat{\mathbf{i}} - 7\hat{\mathbf{j}} + \hat{\mathbf{k}}) = 0$$

[∵ vector along line (i) is $(10\hat{\mathbf{i}} - 7\hat{\mathbf{j}} + \hat{\mathbf{k}})$]

$$\begin{aligned} \Rightarrow [(10r-5)\hat{\mathbf{i}} + (-7r+3)\hat{\mathbf{j}} + (r-4)\hat{\mathbf{k}}] \cdot [10\hat{\mathbf{i}} - 7\hat{\mathbf{j}} + \hat{\mathbf{k}}] &= 0 \\ \Rightarrow 10(10r-5) - 7(3-7r) + (r-4) &= 0 \\ \Rightarrow 100r - 50 - 21 + 49r + r - 4 &= 0 \\ \Rightarrow 150r = 75 \Rightarrow r &= \frac{1}{2} \end{aligned}$$

So, the foot of perpendicular is $A\left(2, -\frac{3}{2}, \frac{1}{2}\right)$

[put $r = \frac{1}{2}$ in the coordinates of point A]

Now, perpendicular distance of point $P(2, -1, 4)$ from the line (i) is

$$\begin{aligned} PA &= \sqrt{(2-2)^2 + \left(-\frac{3}{2}+1\right)^2 + \left(\frac{1}{2}-4\right)^2} \\ &= \sqrt{\frac{1}{4} + \frac{49}{4}} = \sqrt{\frac{50}{4}} = \frac{5}{\sqrt{2}} \end{aligned}$$

which lies in $(3, 4)$.

15. The normal vector to the plane containing the vectors $(\hat{\mathbf{i}} + \hat{\mathbf{j}} + \hat{\mathbf{k}})$ and $(\hat{\mathbf{i}} + 2\hat{\mathbf{j}} + 3\hat{\mathbf{k}})$ is

$$\mathbf{n} = (\hat{\mathbf{i}} + \hat{\mathbf{j}} + \hat{\mathbf{k}}) \times (\hat{\mathbf{i}} + 2\hat{\mathbf{j}} + 3\hat{\mathbf{k}})$$

$$= \begin{vmatrix} \hat{\mathbf{i}} & \hat{\mathbf{j}} & \hat{\mathbf{k}} \\ 1 & 1 & 1 \\ 1 & 2 & 3 \end{vmatrix}$$

$$= \hat{\mathbf{i}}(3-2) - \hat{\mathbf{j}}(3-1) + \hat{\mathbf{k}}(2-1) = \hat{\mathbf{i}} - 2\hat{\mathbf{j}} + \hat{\mathbf{k}}$$

Now, magnitude of the projection of vector $2\hat{\mathbf{i}} + 3\hat{\mathbf{j}} + \hat{\mathbf{k}}$ on normal vector \mathbf{n} is

$$\begin{aligned} \frac{|(2\hat{\mathbf{i}} + 3\hat{\mathbf{j}} + \hat{\mathbf{k}}) \cdot \mathbf{n}|}{|\mathbf{n}|} &= \frac{|(2\hat{\mathbf{i}} + 3\hat{\mathbf{j}} + \hat{\mathbf{k}}) \cdot (\hat{\mathbf{i}} - 2\hat{\mathbf{j}} + \hat{\mathbf{k}})|}{\sqrt{1+4+1}} \\ &= \frac{|2-6+1|}{\sqrt{6}} = \frac{3}{\sqrt{6}} = \sqrt{\frac{3}{2}} \text{ units} \end{aligned}$$

16. Equations of given planes are

$$2x - y - 4 = 0 \quad \dots(i)$$

and $y + 2z - 4 = 0 \quad \dots(ii)$

Now, equation of family of planes passes through the line of intersection of given planes (i) and (ii) is

$$(2x - y - 4) + \lambda(y + 2z - 4) = 0 \quad \dots(iii)$$

According to the question, Plane (iii) passes through the point $(1, 1, 0)$, so

$$\begin{aligned} (2-1-4) + \lambda(1+0-4) &= 0 \\ \Rightarrow -3 - 3\lambda &= 0 \\ \Rightarrow \lambda &= -1 \end{aligned}$$

Now, equation of required plane can be obtained by putting $\lambda = -1$ in the equation of plane (iii).

$$\begin{aligned} \Rightarrow (2x - y - 4) - 1(y + 2z - 4) &= 0 \\ \Rightarrow 2x - y - 4 - y - 2z + 4 &= 0 \\ \Rightarrow 2x - 2y - 2z &= 0 \\ \Rightarrow x - y - z &= 0 \end{aligned}$$

17. Clearly, direction ratios of given line are $2, 1, -2$ and direction ratios of normal to the given plane are $1, -2, -k$.

As we know angle 'θ' between line and plane can be obtained by

$$\sin \theta = \frac{|a_1 a_2 + b_1 b_2 + c_1 c_2|}{\sqrt{a_1^2 + b_1^2 + c_1^2} \sqrt{a_2^2 + b_2^2 + c_2^2}}$$

$$\text{So, } \sin \theta = \frac{|2-2+2k|}{\sqrt{4+1+4} \sqrt{1+4+k^2}}$$

$$\Rightarrow \sin\left(\cos^{-1} \frac{2\sqrt{2}}{3}\right) = \frac{|2k|}{3\sqrt{5+k^2}} \quad \left[\text{given } \theta = \cos^{-1} \frac{2\sqrt{2}}{3} \right]$$

$$\begin{aligned} \Rightarrow \frac{2|k|}{3\sqrt{5+k^2}} = \frac{1}{3} \left[\because \cos \theta = \frac{2\sqrt{2}}{3} \Rightarrow \sin \theta = \frac{1}{3} \Rightarrow \theta = \sin^{-1} \frac{1}{3} \right. \\ \left. \Rightarrow \cos^{-1} \frac{2\sqrt{2}}{3} = \sin^{-1} \frac{1}{3} \right] \end{aligned}$$

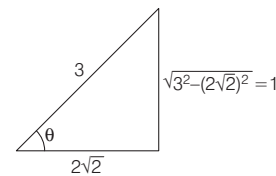

$$\begin{aligned} \Rightarrow 4k^2 &= 5 + k^2 \\ \Rightarrow 3k^2 &= 5 \\ \Rightarrow k &= \pm \sqrt{\frac{5}{3}} \end{aligned}$$

18. According to the question points $(-\lambda^2, 1, 1)$, $(1, -\lambda^2, 1)$ and $(1, 1, -\lambda^2)$ are coplanar with the point $(-1, -1, 1)$, so

$$\begin{vmatrix} 1-\lambda^2 & 2 & 0 \\ 2 & 1-\lambda^2 & 0 \\ 2 & 2 & -\lambda^2-1 \end{vmatrix} = 0$$

$$\left[\because \text{condition of coplanarity is } \begin{vmatrix} x_2-x_1 & y_2-y_1 & z_2-z_1 \\ x_3-x_1 & y_3-y_1 & z_3-z_1 \\ x_4-x_1 & y_4-y_1 & z_4-z_1 \end{vmatrix} = 0 \right]$$

$$\Rightarrow (-1-\lambda^2) [(1-\lambda^2)^2 - 4] = 0$$

594 3D Geometry

$$\begin{aligned} \Rightarrow (1 + \lambda^2) [(1 - \lambda^2 - 2)(1 - \lambda^2 + 2)] &= 0 \\ \Rightarrow (1 + \lambda^2)^2 (3 - \lambda^2) &= 0 \\ \Rightarrow \lambda^2 &= 3 \quad [\because 1 + \lambda^2 \neq 0 \quad \forall \lambda \in \mathbb{R}] \\ \Rightarrow \lambda &= \pm\sqrt{3} \end{aligned}$$

19. Let the equation of plane, containing the two lines

$$\frac{x+2}{3} = \frac{y-2}{5} = \frac{z+5}{7}$$

and $\frac{x-1}{1} = \frac{y-4}{4} = \frac{z+4}{7}$ is

$$a(x+2) + b(y-2) + c(z+5) = 0 \quad \dots (i)$$

\therefore Plane (i) contain lines, so

$$3a + 5b + 7c = 0 \quad \dots (ii)$$

and $a + 4b + 7c = 0 \quad \dots (iii)$

From Eqs. (ii) and (iii), we get

$$\frac{a}{35-28} = \frac{b}{7-21} = \frac{c}{12-5}$$

$$\Rightarrow \frac{a}{7} = \frac{b}{-14} = \frac{c}{7}$$

$$\Rightarrow \frac{a}{1} = \frac{b}{-2} = \frac{c}{1}$$

So, equation of plane will be

$$1(x+2) - 2(y-2) + 1(z+5) = 0$$

$$\Rightarrow x - 2y + z + 11 = 0 \quad \dots (iv)$$

Now, perpendicular distance from origin to plane is

$$= \frac{11}{\sqrt{1+4+1}} = \frac{11}{\sqrt{6}}$$

[\therefore perpendicular distance from origin to the plane

$$ax + by + cz + d = 0, \text{ is } \frac{|d|}{\sqrt{a^2 + b^2 + c^2}}]$$

20. Let $\frac{x-3}{1} = \frac{y+1}{3} = \frac{z-6}{-1} = a$ (say). Then, any point on this line is of the form $P(a+3, 3a-1, -a+6)$

Similarly, any point on the line $\frac{x+5}{7} = \frac{y-2}{-6} = \frac{z-3}{4} =$

b (say), is of the form $Q(7b-5, -6b+2, 4b+3)$

Now, if the lines are intersect, then $P=Q$ for some a and b .

$$\begin{aligned} \Rightarrow a + 3 &= 7b - 5 \\ 3a - 1 &= -6b + 2 \end{aligned}$$

and $-a + 6 = 4b + 3$

$$\Rightarrow a - 7b = -8, \quad a + 2b = 1$$

and $a + 4b = 3$

On solving $a - 7b = -8$

and $a + 2b = 1$, we get

$$b = 1 \text{ and } a = -1,$$

which also satisfy $a + 4b = 3$

$$\therefore P = Q \equiv (2, -4, 7)$$

for $a = -1$ and $b = 1$

Thus, coordinates of point R are $(2, -4, 7)$

and reflection of R in xy -plane is $(2, -4, -7)$

21. According to given information, we have the following figure.

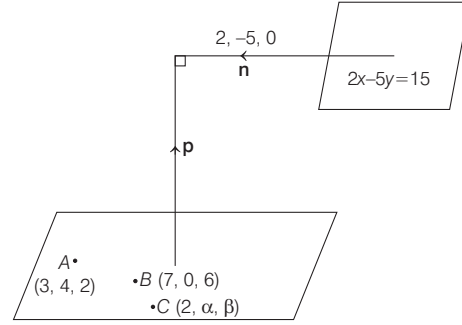

From figure, it is clear that

$$(\mathbf{AB} \times \mathbf{BC}) = \mathbf{p} \text{ and } \mathbf{n} = 2\hat{i} - 5\hat{j} + 0\hat{k}$$

$$\therefore \mathbf{p} = \begin{vmatrix} \hat{i} & \hat{j} & \hat{k} \\ 4 & -4 & 4 \\ -5 & \alpha & \beta - 6 \end{vmatrix}$$

$$\begin{aligned} [\because \mathbf{AB} &= (7-3)\hat{i} + (0-4)\hat{j} + (6-2)\hat{k} \\ &= 4\hat{i} - 4\hat{j} + 4\hat{k} \text{ and } \mathbf{BC} = (2-7)\hat{i} + (\alpha-0)\hat{j} + (\beta-6)\hat{k} \\ &= -5\hat{i} + \alpha\hat{j} + (\beta-6)\hat{k}] \\ &= \hat{i}(-4\beta + 24 - 4\alpha) - \hat{j}(4\beta - 24 + 20) + \hat{k}(4\alpha - 20) \end{aligned}$$

$$\Rightarrow \mathbf{p} = (24 - 4\alpha - 4\beta)\hat{i} + \hat{j}(4 - 4\beta) + \hat{k}(4\alpha - 20)$$

Now, as the planes are perpendicular, therefore $\mathbf{p} \cdot \mathbf{n} = 0$

$$\begin{aligned} \Rightarrow ((24 - 4\alpha - 4\beta)\hat{i} + (4 - 4\beta)\hat{j} + (4\alpha - 20)\hat{k}) \\ \cdot (2\hat{i} - 5\hat{j} + 0\hat{k}) = 0 \end{aligned}$$

$$\Rightarrow 2(24 - 4\alpha - 4\beta) - 5(4 - 4\beta) + 0 = 0$$

$$\Rightarrow 8(6 - \alpha - \beta) - 4(5 - 5\beta) = 0$$

$$\Rightarrow 12 - 2\alpha - 2\beta - 5 + 5\beta = 0 \Rightarrow 2\alpha - 3\beta = 7$$

22. Let the direction vector of the line

$$\frac{x-3}{2} = \frac{y+2}{-1} = \frac{z-1}{3} \text{ is } \mathbf{b} = 2\hat{i} - \hat{j} + 3\hat{k}.$$

Since, the required plane contains this line and its projection along the plane $2x + 3y - z = 5$, it will also contain the normal of the plane $2x + 3y - z = 5$.

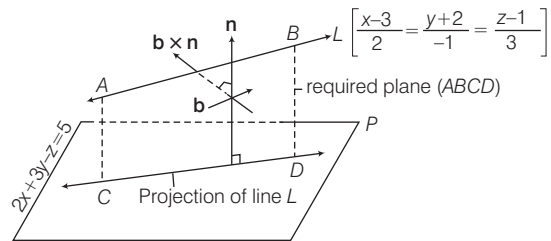

Normal vector of the plane $2x + 3y - z = 5$ is $\mathbf{n} = 2\hat{i} + 3\hat{j} - \hat{k}$.

Now, the required plane contains $\mathbf{b} = 2\hat{i} - \hat{j} + 3\hat{k}$ and $\mathbf{n} = 2\hat{i} + 3\hat{j} - \hat{k}$.

\therefore Normal of the required plane is $\mathbf{b} \times \mathbf{n}$.

Since, the plane contains the line

$$\frac{x-3}{2} = \frac{y+2}{-1} = \frac{z-1}{3}, \text{ therefore it also contains the point}$$

$$\mathbf{a} = 3\hat{\mathbf{i}} - 2\hat{\mathbf{j}} + \hat{\mathbf{k}}.$$

Now, the equation of required plane is $(\mathbf{r} - \mathbf{a}) \cdot (\mathbf{b} \times \mathbf{n}) = 0$

$$\begin{vmatrix} x-3 & y+2 & z-1 \\ 2 & -1 & 3 \\ 2 & 3 & -1 \end{vmatrix} = 0$$

$$\Rightarrow (x-3)[1-9] - (y+2)[-2-6] + (z-1)[6+2] = 0$$

$$\Rightarrow -8x + 8y + 8z + 32 = 0 \Rightarrow x - y - z = 4$$

Note that $(2, 0, -2)$ is the only point which satisfy above equation.

23. Let the equation of plane be

$$a(x-0) + b(y+1) + c(z-0) = 0$$

[∵ Equation of plane passing through a point

$$(x_1, y_1, z_1) \text{ is given by } a(x-x_1) + b(y-y_1) + c(z-z_1) = 0]$$

$$\Rightarrow ax + by + cz + b = 0 \quad \dots \text{(i)}$$

Since, it also passes through $(0, 0, 1)$, therefore, we get

$$c + b = 0 \quad \dots \text{(ii)}$$

Now, as angle between the planes

$$ax + by + cz + b = 0$$

$$\text{and } y - z + 5 = 0 \text{ is } \frac{\pi}{4}.$$

$$\therefore \cos\left(\frac{\pi}{4}\right) = \frac{|\mathbf{n}_1 \cdot \mathbf{n}_2|}{|\mathbf{n}_1||\mathbf{n}_2|}, \text{ where } \mathbf{n}_1 = a\hat{\mathbf{i}} + b\hat{\mathbf{j}} + c\hat{\mathbf{k}}$$

$$\text{and } \mathbf{n}_2 = 0\hat{\mathbf{i}} + \hat{\mathbf{j}} - \hat{\mathbf{k}}$$

$$\Rightarrow \frac{1}{\sqrt{2}} = \frac{|(a\hat{\mathbf{i}} + b\hat{\mathbf{j}} + c\hat{\mathbf{k}}) \cdot (0\hat{\mathbf{i}} + \hat{\mathbf{j}} - \hat{\mathbf{k}})|}{\sqrt{a^2 + b^2 + c^2} \sqrt{0+1+1}}$$

$$= \frac{|b - c|}{\sqrt{a^2 + b^2 + c^2} \sqrt{2}}$$

$$\Rightarrow a^2 + b^2 + c^2 = |b - c|^2 = (b - c)^2 = b^2 + c^2 - 2bc$$

$$\Rightarrow a^2 = -2bc$$

$$\Rightarrow a^2 = 2b^2 \quad [\text{Using Eq. (ii)}]$$

$$\Rightarrow a = \pm\sqrt{2}b$$

$$\Rightarrow \text{Direction ratios } (a, b, c) = (\pm\sqrt{2}, 1, -1)$$

So, options (b) and (c) are correct because

$2, \sqrt{2}, -\sqrt{2}$ and $\sqrt{2}, 1, -1$ are multiple of each other.

24. Let the given points be $A(-3, -3, 4)$ and $B(3, 7, 6)$.

Then, mid-point of line joining A, B is

$$P\left(\frac{-3+3}{2}, \frac{-3+7}{2}, \frac{4+6}{2}\right) = P(0, 2, 5)$$

∵ The required plane is perpendicular

bisector of line joining A, B , so direction ratios of normal to the plane is proportional to the direction ratios of line joining A, B .

So, direction ratios of normal to the plane are 6, 10, 2.

[∵ DR's of AB are $3+3, 7+3, 6-4$, i.e. $6, 10, 2$]

Now, equation of plane is given by

$$a(x-x_1) + b(y-y_1) + c(z-z_1) = 0$$

$$6(x-0) + 10(y-2) + 2(z-5) = 0$$

[∵ $P(0, 2, 5)$ line on the plane]

$$\Rightarrow 3x + 5y - 10 + z - 5 = 0$$

$$\Rightarrow 3x + 5y + z = 15 \quad \dots \text{(i)}$$

On checking all the options, the option $(4, 1, -2)$ satisfy the equation of plane (i).

25. Given equation of line is

$$\frac{x-4}{2} = \frac{y-5}{2} = \frac{z-3}{1} = r \text{ (let)} \quad \dots \text{(i)}$$

$$\Rightarrow x = 2r + 4; y = 2r + 5 \text{ and } z = r + 3$$

∴ General point on the line (i) is

$$P(2r+4, 2r+5, r+3)$$

So, the point of intersection of line (i) and plane $x + y + z = 2$ will be of the form $P(2r+4, 2r+5, r+3)$ for some $r \in R$.

$$\Rightarrow (2r+4) + (2r+5) + (r+3) = 2$$

[∵ the point will lie on the plane]

$$\Rightarrow 5r = -10 \Rightarrow r = -2$$

So, the point of intersection is $P(0, 1, 1)$

[putting $r = -2$ in $(2r+4, 2r+5, r+3)$]

Now, on checking the options, we get

$$\frac{x-1}{1} = \frac{y-3}{2} = \frac{z+4}{-5} \text{ contain the point } (0, 1, 1)$$

26. Let \mathbf{a} be the position vector of the given point $(4, -1, 2)$.

Then, $\mathbf{a} = 4\hat{\mathbf{i}} - \hat{\mathbf{j}} + 2\hat{\mathbf{k}}$

The direction vector of the lines

$$\frac{x+2}{3} = \frac{y-2}{-1} = \frac{z+1}{2} \text{ and } \frac{x-2}{1} = \frac{y-3}{2} = \frac{z-4}{3}$$

are respectively

$$\mathbf{b}_1 = 3\hat{\mathbf{i}} - \hat{\mathbf{j}} + 2\hat{\mathbf{k}}$$

$$\text{and } \mathbf{b}_2 = \hat{\mathbf{i}} + 2\hat{\mathbf{j}} + 3\hat{\mathbf{k}}$$

Now, as the plane is parallel to both \mathbf{b}_1 and \mathbf{b}_2

[∵ plane is parallel to the given lines]

So, normal vector (\mathbf{n}) of the plane is perpendicular to both \mathbf{b}_1 and \mathbf{b}_2 .

$$\Rightarrow \mathbf{n} = \mathbf{b}_1 \times \mathbf{b}_2 \text{ and}$$

Required equation of plane is

$$(\mathbf{r} - \mathbf{a}) \cdot \mathbf{n} = 0 \Rightarrow (\mathbf{r} - \mathbf{a}) \cdot (\mathbf{b}_1 \times \mathbf{b}_2) = 0$$

$$\Rightarrow \begin{vmatrix} x-4 & y+1 & z-2 \\ 3 & -1 & 2 \\ 1 & 2 & 3 \end{vmatrix} = 0$$

$$\left[\begin{array}{l} \because \mathbf{r} - \mathbf{a} = (x\hat{\mathbf{i}} + y\hat{\mathbf{j}} + z\hat{\mathbf{k}}) - (4\hat{\mathbf{i}} - \hat{\mathbf{j}} + 2\hat{\mathbf{k}}) \\ = (x-4)\hat{\mathbf{i}} + (y+1)\hat{\mathbf{j}} + (z-2)\hat{\mathbf{k}} \\ \text{and we know that, } [\mathbf{a} \ \mathbf{b} \ \mathbf{c}] = \mathbf{a} \cdot (\mathbf{b} \times \mathbf{c}) \\ = \begin{vmatrix} a_1 & a_2 & a_3 \\ b_1 & b_2 & b_3 \\ c_1 & c_2 & c_3 \end{vmatrix} \end{array} \right]$$

$$\Rightarrow (x-4)(-3-4) - (y+1)(9-2) + (z-2)(6+1) = 0$$

596 3D Geometry

$$\begin{aligned} \Rightarrow -7(x-4) - 7(y+1) + 7(z-2) &= 0 \\ \Rightarrow (x-4) + (y+1) - (z-2) &= 0 \\ \Rightarrow x + y - z - 1 &= 0 \end{aligned}$$

(1, 1, 1) is the only point that satisfies.

27. Given equation of line is

$$\mathbf{r} = (1 - 3\mu)\hat{\mathbf{i}} + (\mu - 1)\hat{\mathbf{j}} + (2 + 5\mu)\hat{\mathbf{k}}$$

Clearly, any point on the above line is of the form $(1 - 3\mu, \mu - 1, 2 + 5\mu)$

Let A be $(-3\mu + 1, \mu - 1, 5\mu + 2)$ for some $\mu \in R$.

$$\begin{aligned} \text{Then, } \mathbf{AB} &= (3 - (-3\mu + 1))\hat{\mathbf{i}} + (2 - (\mu - 1))\hat{\mathbf{j}} \\ &\quad + (6 - (5\mu + 2))\hat{\mathbf{k}} \quad [\because \mathbf{AB} = \mathbf{OB} - \mathbf{OA}] \\ &= (3\mu + 2)\hat{\mathbf{i}} + (3 - \mu)\hat{\mathbf{j}} + (4 - 5\mu)\hat{\mathbf{k}} \quad \dots (i) \end{aligned}$$

Normal vector (\mathbf{n}) of the plane $x - 4y + 3z = 1$ is

$$\mathbf{n} = \hat{\mathbf{i}} - 4\hat{\mathbf{j}} + 3\hat{\mathbf{k}} \quad \dots (ii)$$

$\therefore \mathbf{AB}$ is parallel to the plane.

$\therefore \mathbf{n}$ is perpendicular to the \mathbf{AB} .

$$\Rightarrow \mathbf{AB} \cdot \mathbf{n} = 0$$

$$\Rightarrow [(3\mu + 2)\hat{\mathbf{i}} + (3 - \mu)\hat{\mathbf{j}} + (4 - 5\mu)\hat{\mathbf{k}}] \cdot [\hat{\mathbf{i}} - 4\hat{\mathbf{j}} + 3\hat{\mathbf{k}}] = 0$$

[From Eqs. (i) and (ii)]

$$\Rightarrow (3\mu + 2) - 4(3 - \mu) + 3(4 - 5\mu) = 0 \Rightarrow -8\mu + 2 = 0$$

$$\Rightarrow \mu = \frac{1}{4}$$

28. Let P_1 be the plane containing the lines

$$\frac{x}{3} = \frac{y}{4} = \frac{z}{2} \quad \text{and} \quad \frac{x}{4} = \frac{y}{2} = \frac{z}{3}$$

For these two lines, direction vectors are

$$\mathbf{b}_1 = 3\hat{\mathbf{i}} + 4\hat{\mathbf{j}} + 2\hat{\mathbf{k}} \quad \text{and} \quad \mathbf{b}_2 = 4\hat{\mathbf{i}} + 2\hat{\mathbf{j}} + 3\hat{\mathbf{k}}$$

A vector along the normal to the plane P_1 is given by

$$\begin{aligned} \mathbf{n}_1 &= \mathbf{b}_1 \times \mathbf{b}_2 = \begin{vmatrix} \hat{\mathbf{i}} & \hat{\mathbf{j}} & \hat{\mathbf{k}} \\ 3 & 4 & 2 \\ 4 & 2 & 3 \end{vmatrix} \\ &= \hat{\mathbf{i}}(12 - 4) - \hat{\mathbf{j}}(9 - 8) + \hat{\mathbf{k}}(6 - 16) = 8\hat{\mathbf{i}} - \hat{\mathbf{j}} - 10\hat{\mathbf{k}} \end{aligned}$$

Let P_2 be the plane containing the line $\frac{x}{2} = \frac{y}{3} = \frac{z}{4}$ and

perpendicular to plane P_1 .

For the line $\frac{x}{2} = \frac{y}{3} = \frac{z}{4}$, the direction vector is

$\mathbf{b} = 2\hat{\mathbf{i}} + 3\hat{\mathbf{j}} + 4\hat{\mathbf{k}}$ and it passes through the point with position vector $\mathbf{a} = 0\hat{\mathbf{i}} + 0\hat{\mathbf{j}} + 0\hat{\mathbf{k}}$.

$\therefore P_2$ is perpendicular to P_1 , therefore \mathbf{n}_1 and \mathbf{b} lies along the plane.

Also, P_2 also passes through the point with position vector \mathbf{a} .

\therefore Equation of plane P_2 is given by

$$(\mathbf{r} - \mathbf{a}) \cdot (\mathbf{n}_1 \times \mathbf{b}) = 0 \Rightarrow \begin{vmatrix} x-0 & y-0 & z-0 \\ 8 & -1 & -10 \\ 2 & 3 & 4 \end{vmatrix} = 0$$

$$\begin{aligned} \Rightarrow x(-4 + 30) - y(32 + 20) + z(24 + 2) &= 0 \\ \Rightarrow 26x - 52y + 26z &= 0 \\ \Rightarrow x - 2y + z &= 0 \end{aligned}$$

29.

Key Idea Equation of plane through the intersection of two planes P_1 and P_2 is given by $P_1 + \lambda P_2 = 0$

The plane through the intersection of the planes $x + y + z - 1 = 0$ and $2x + 3y - z + 4 = 0$ is given by

$$(x + y + z - 1) + \lambda(2x + 3y - z + 4) = 0,$$

where $\lambda \in R$

$$\Rightarrow (1 + 2\lambda)x + (1 + 3\lambda)y + (1 - \lambda)z + (4\lambda - 1) = 0,$$

where $\lambda \in R$... (i)

Since, this plane is parallel to Y -axis, therefore its normal is perpendicular to Y -axis.

$$\Rightarrow \{(1 + 2\lambda)\hat{\mathbf{i}} + (1 + 3\lambda)\hat{\mathbf{j}} + (1 - \lambda)\hat{\mathbf{k}}\} \cdot \hat{\mathbf{j}} = 0$$

$$\Rightarrow 1 + 3\lambda = 0$$

$$\Rightarrow \lambda = -\frac{1}{3}$$

Now, required equation of plane is

$$\left(1 - \frac{2}{3}\right)x + \left(1 - \frac{3}{3}\right)y + \left(1 + \frac{1}{3}\right)z + \left(-\frac{4}{3} - 1\right) = 0$$

[substituting $\lambda = -\frac{1}{3}$ in Eq. (i)]

$$\Rightarrow x + 4z - 7 = 0$$

Here, only $(3, 2, 1)$ satisfy the above equation.

30. Any point on the line $\frac{x+1}{-3} = \frac{y-3}{2} = \frac{z-2}{-1}$ is of the form $(-3\lambda - 1, 2\lambda + 3, -\lambda + 2)$

$$\begin{aligned} [\text{take } \frac{x+1}{-3} = \frac{y-3}{2} = \frac{z-2}{-1} = \lambda \Rightarrow x = -3\lambda - 1, \\ y = 2\lambda + 3 \text{ and } z = -\lambda + 2] \end{aligned}$$

So, the coordinates of point of intersection of two lines will be $(-3\lambda - 1, 2\lambda + 3, -\lambda + 2)$ for some $\lambda \in R$.

Let the point $A \equiv (-3\lambda - 1, 2\lambda + 3, -\lambda + 2)$ and $B \equiv (-4, 3, 1)$

Then, $\mathbf{AB} = \mathbf{OB} - \mathbf{OA}$

$$\begin{aligned} &= (-4\hat{\mathbf{i}} + 3\hat{\mathbf{j}} + \hat{\mathbf{k}}) - \{(-3\lambda - 1)\hat{\mathbf{i}} + (2\lambda + 3)\hat{\mathbf{j}} + (-\lambda + 2)\hat{\mathbf{k}}\} \\ &= (3\lambda - 3)\hat{\mathbf{i}} - 2\lambda\hat{\mathbf{j}} + (\lambda - 1)\hat{\mathbf{k}} \end{aligned}$$

Now, as the line is parallel to the given plane, therefore \mathbf{AB} will be parallel to the given plane and so \mathbf{AB} will be perpendicular to the normal of plane.

$$\Rightarrow \mathbf{AB} \cdot \mathbf{n} = 0, \text{ where } \mathbf{n} = \hat{\mathbf{i}} + 2\hat{\mathbf{j}} - \hat{\mathbf{k}} \text{ is normal to the plane.}$$

$$\Rightarrow ((3\lambda - 3)\hat{\mathbf{i}} - 2\lambda\hat{\mathbf{j}} + (\lambda - 1)\hat{\mathbf{k}}) \cdot (\hat{\mathbf{i}} + 2\hat{\mathbf{j}} - \hat{\mathbf{k}}) = 0$$

$$\Rightarrow 3(\lambda - 1) - 4\lambda + (-1)(\lambda - 1) = 0$$

$$[\because \text{If } \mathbf{a} = a_1\hat{\mathbf{i}} + a_2\hat{\mathbf{j}} + a_3\hat{\mathbf{k}} \text{ and } \mathbf{b} = b_1\hat{\mathbf{i}} + b_2\hat{\mathbf{j}} + b_3\hat{\mathbf{k}},$$

$$\text{then } \mathbf{a} \cdot \mathbf{b} = a_1b_1 + a_2b_2 + a_3b_3]$$

$$\Rightarrow 3\lambda - 3 - 4\lambda - \lambda + 1 = 0$$

$$\Rightarrow -2\lambda = 2$$

$$\Rightarrow \lambda = -1$$

Now, the required equation is the equation of line joining $A(2, 1, 3)$ and $B(-4, 3, 1)$, which is

$$\frac{x - (-4)}{2 - (-4)} = \frac{y - 3}{1 - 3} = \frac{z - 1}{3 - 1}$$

[∵ Equation of line joining (x_1, y_1, z_1) and (x_2, y_2, z_2) is $\frac{x - x_1}{x_2 - x_1} = \frac{y - y_1}{y_2 - y_1} = \frac{z - z_1}{z_2 - z_1}$]

$$\Rightarrow \frac{x + 4}{6} = \frac{y - 3}{-2} = \frac{z - 1}{2}$$

$$\text{or } \frac{x + 4}{3} = \frac{y - 3}{-1} = \frac{z - 1}{1} \quad [\text{multiplying by 2}]$$

31. L_1 is the line of intersection of the plane $2x - 2y + 3z - 2 = 0$ and $x - y + z + 1 = 0$ and L_2 is the line of intersection of the plane $x + 2y - z - 3 = 0$ and $3x - y + 2z - 1 = 0$

Since L_1 is parallel to $\begin{vmatrix} \hat{i} & \hat{j} & \hat{k} \\ 2 & -2 & 3 \\ 1 & -1 & 1 \end{vmatrix} = \hat{i} + \hat{j}$

L_2 is parallel to $\begin{vmatrix} \hat{i} & \hat{j} & \hat{k} \\ 1 & 2 & -1 \\ 3 & -1 & 2 \end{vmatrix} = 3\hat{i} - 5\hat{j} - 7\hat{k}$

Also, L_2 passes through $(\frac{5}{7}, \frac{8}{7}, 0)$.
[put $z = 0$ in last two planes]

So, equation of plane is $\begin{vmatrix} x - \frac{5}{7} & y - \frac{8}{7} & z \\ 1 & 1 & 0 \\ 3 & -5 & -7 \end{vmatrix} = 0 \Rightarrow 7x - 7y + 8z + 3 = 0$

Now, perpendicular distance from origin is

$$\frac{|3|}{\sqrt{7^2 + 7^2 + 8^2}} = \frac{3}{\sqrt{162}} = \frac{1}{3\sqrt{2}}$$

32. **Key Idea** length of projection of the line segment joining \mathbf{a}_1 and \mathbf{a}_2 on the plane $\mathbf{r} \cdot \mathbf{n} = d$ is $\frac{(\mathbf{a}_2 - \mathbf{a}_1) \times \mathbf{n}}{|\mathbf{n}|}$

Length of projection the line segment joining the points $(5, -1, 4)$ and $(4, -1, 3)$ on the plane $x + y + z = 7$ is

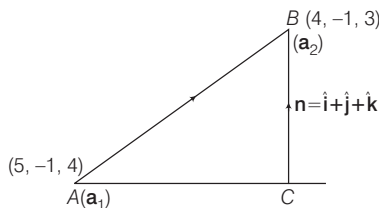

$$AC = \frac{|(\mathbf{a}_2 - \mathbf{a}_1) \times \mathbf{n}|}{|\mathbf{n}|} = \frac{|(-\hat{i} - \hat{k}) \times (\hat{i} + \hat{j} + \hat{k})|}{|\hat{i} + \hat{j} + \hat{k}|}$$

$$AC = \frac{|\hat{i} - \hat{k}|}{\sqrt{3}} \Rightarrow AC = \frac{\sqrt{2}}{\sqrt{3}} = \sqrt{\frac{2}{3}}$$

Alternative Method

Clearly, DR's of AB are $4 - 5, -1 + 1, 3 - 4$, i.e. $-1, 0, -1$ and DR's of normal to plane are $1, 1, 1$.

Now, let θ be the angle between the line and plane,

$$\text{then } \theta \text{ is given by } \sin \theta = \frac{|-1 + 0 - 1|}{\sqrt{(-1)^2 + (-1)^2} \sqrt{1^2 + 1^2 + 1^2}} = \frac{2}{\sqrt{2}\sqrt{3}} = \sqrt{\frac{2}{3}}$$

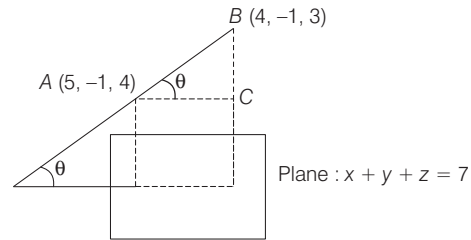

$$\Rightarrow \sin \theta = \sqrt{\frac{2}{3}} \Rightarrow \cos \theta = \sqrt{1 - \sin^2 \theta} = \sqrt{1 - \frac{2}{3}} = \frac{1}{\sqrt{3}}$$

$$\text{Clearly, length of projection} = AB \cos \theta = \sqrt{2} \cdot \frac{1}{\sqrt{3}} \quad [\because AB = \sqrt{2}] = \sqrt{\frac{2}{3}}$$

33. **Key Idea** If any vector \mathbf{x} is coplanar with the vector \mathbf{y} and \mathbf{z} , then $\mathbf{x} = \lambda \mathbf{y} + \mu \mathbf{z}$

Here, \mathbf{u} is coplanar with \mathbf{a} and \mathbf{b} .

$$\therefore \mathbf{u} = \lambda \mathbf{a} + \mu \mathbf{b}$$

Dot product with \mathbf{a} , we get

$$\mathbf{u} \cdot \mathbf{a} = \lambda (\mathbf{a} \cdot \mathbf{a}) + \mu (\mathbf{b} \cdot \mathbf{a}) \Rightarrow 0 = 14\lambda + 2\mu \quad \dots(i)$$

$$[\because \mathbf{a} = 2\hat{i} + 3\hat{j} - \hat{k}, \mathbf{b} = \hat{j} + \hat{k}, \mathbf{u} \cdot \mathbf{a} = 0]$$

Dot product with \mathbf{b} , we get

$$\mathbf{u} \cdot \mathbf{b} = \lambda (\mathbf{a} \cdot \mathbf{b}) + \mu (\mathbf{b} \cdot \mathbf{b}) \Rightarrow 24 = 2\lambda + 2\mu \quad \dots(ii) [\because \mathbf{u} \cdot \mathbf{b} = 24]$$

Solving Eqs. (i) and (ii), we get

$$\lambda = -2, \mu = 14$$

Dot product with \mathbf{u} , we get

$$|\mathbf{u}|^2 = \lambda (\mathbf{u} \cdot \mathbf{a}) + \mu (\mathbf{u} \cdot \mathbf{b}) \Rightarrow |\mathbf{u}|^2 = -2(0) + 14(24) \Rightarrow |\mathbf{u}|^2 = 336$$

34. Any line parallel to $\frac{x}{1} = \frac{y}{4} = \frac{z}{5}$ and passing through $P(1, -2, 3)$ is

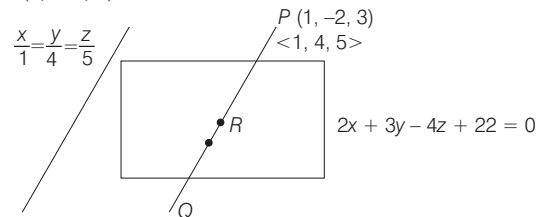

$$\frac{x - 1}{1} = \frac{y + 2}{4} = \frac{z - 3}{5} = \lambda \quad (\text{say})$$

Any point on above line can be written as $(\lambda + 1, 4\lambda - 2, 5\lambda + 3)$.

598 3D Geometry

∴ Coordinates of R are $(\lambda + 1, 4\lambda - 2, 5\lambda + 3)$.

Since, point R lies on the above plane.

$$\therefore 2(\lambda + 1) + 3(4\lambda - 2) - 4(5\lambda + 3) + 22 = 0$$

$$\Rightarrow \lambda = 1$$

So, point R is $(2, 2, 8)$.

$$\text{Now, } PR = \sqrt{(2-1)^2 + (2+2)^2 + (8-3)^2} = \sqrt{42}$$

$$\therefore PQ = 2PR = 2\sqrt{42}$$

35. Given, equations of lines are

$$\frac{x-1}{1} = \frac{y+2}{-2} = \frac{z-4}{3}$$

and

$$\frac{x-2}{2} = \frac{y+1}{-1} = \frac{z+7}{-1}$$

Let $\mathbf{n}_1 = \hat{i} - 2\hat{j} + 3\hat{k}$ and $\mathbf{n}_2 = 2\hat{i} - \hat{j} - \hat{k}$

∴ Any vector \mathbf{n} perpendicular to both $\mathbf{n}_1, \mathbf{n}_2$ is given by

$$\mathbf{n} = \mathbf{n}_1 \times \mathbf{n}_2$$

$$\Rightarrow \mathbf{n} = \begin{vmatrix} \hat{i} & \hat{j} & \hat{k} \\ 1 & -2 & 3 \\ 2 & -1 & -1 \end{vmatrix} = 5\hat{i} + 7\hat{j} + 3\hat{k}$$

∴ Equation of a plane passing through $(1, -1, -1)$ and perpendicular to \mathbf{n} is given by

$$5(x-1) + 7(y+1) + 3(z+1) = 0$$

$$\Rightarrow 5x + 7y + 3z + 5 = 0$$

$$\therefore \text{Required distance} = \frac{|5 + 21 - 21 + 5|}{\sqrt{5^2 + 7^2 + 3^2}} = \frac{10}{\sqrt{83}} \text{ units}$$

36. Let the equation of plane be $ax + by + cz = 1$. Then

$$a + b + c = 1$$

$$2a + b - 2c = 0$$

$$3a - 6b - 2c = 0 \Rightarrow a = 7b, c = \frac{15b}{2}$$

$$b = \frac{2}{31}, a = \frac{14}{31}, c = \frac{15}{31}$$

$$\therefore 14x + 2y + 15z = 31$$

37. Let image of $Q(3, 1, 7)$ w.r.t. $x - y + z = 3$ be $P(\alpha, \beta, \gamma)$.

$$\therefore \frac{\alpha - 3}{1} = \frac{\beta - 1}{-1} = \frac{\gamma - 7}{1} = \frac{-2(3 - 1 + 7 - 3)}{1^2 + (-1)^2 + (1)^2}$$

$$\Rightarrow \alpha - 3 = 1 - \beta = \gamma - 7 = -4$$

$$\therefore \alpha = -1, \beta = 5, \gamma = 3$$

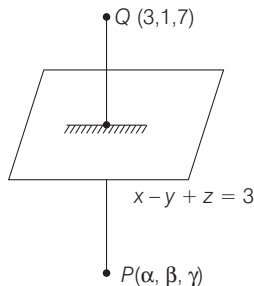

Hence, the image of $Q(3, 1, 7)$ is $P(-1, 5, 3)$.

To find equation of plane passing through $P(-1, 5, 3)$

and containing $\frac{x}{1} = \frac{y}{2} = \frac{z}{1}$

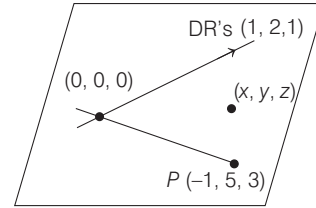

$$\Rightarrow \begin{vmatrix} x-0 & y-0 & z-0 \\ 1-0 & 2-0 & 1-0 \\ -1-0 & 5-0 & 3-0 \end{vmatrix} = 0$$

$$\Rightarrow x(6-5) - y(3+1) + z(5+2) = 0$$

$$\therefore x - 4y + 7z = 0$$

38. Let equation of plane containing the lines

$$2x - 5y + z = 3 \text{ and } x + y + 4z = 5 \text{ be}$$

$$(2x - 5y + z - 3) + \lambda(x + y + 4z - 5) = 0$$

$$\Rightarrow (2 + \lambda)x + (\lambda - 5)y + (4\lambda + 1)z - 3 - 5\lambda = 0 \quad \dots(i)$$

This plane is parallel to the plane $x + 3y + 6z = 1$.

$$\therefore \frac{2 + \lambda}{1} = \frac{\lambda - 5}{3} = \frac{4\lambda + 1}{6}$$

On taking first two equations, we get

$$6 + 3\lambda = \lambda - 5 \Rightarrow 2\lambda = -11 \Rightarrow \lambda = -\frac{11}{2}$$

On taking last two equations, we get

$$6\lambda - 30 = 3 + 12\lambda \Rightarrow -6\lambda = 33 \Rightarrow \lambda = -\frac{11}{2}$$

So, the equation of required plane is

$$\left(2 - \frac{11}{2}\right)x + \left(-\frac{11}{2} - 5\right)y + \left(-\frac{44}{2} + 1\right)z - 3 + 5 \times \frac{11}{2} = 0$$

$$\Rightarrow -\frac{7}{2}x - \frac{21}{2}y - \frac{42}{2}z + \frac{49}{2} = 0$$

$$\Rightarrow x + 3y + 6z - 7 = 0$$

39. Given equation of line is

$$\frac{x-2}{3} = \frac{y+1}{4} = \frac{z-2}{12} = \lambda \quad [\text{say}] \dots(i)$$

and equation of plane is

$$x - y + z = 16 \quad \dots(ii)$$

Any point on the line (i) is, $(3\lambda + 2, 4\lambda - 1, 12\lambda + 2)$

Let this point of intersection of the line and plane.

$$\therefore (3\lambda + 2) - (4\lambda - 1) + (12\lambda + 2) = 16$$

$$\Rightarrow 11\lambda + 5 = 16$$

$$\Rightarrow 11\lambda = 11 \Rightarrow \lambda = 1$$

So, the point of intersection is $(5, 3, 14)$.

Now, distance between the points $(1, 0, 2)$ and $(5, 3, 14)$

$$= \sqrt{(5-1)^2 + (3-0)^2 + (14-2)^2} \\ = \sqrt{16 + 9 + 144} = \sqrt{169} = 13$$

40. Here, plane, line and its image are parallel to each other. So, find any point on the normal to the plane from which the image line will be passed and then find equation of image line.

Here, plane and line are parallel to each other. Equation of normal to the plane through the point (1, 3, 4) is

$$\frac{x-1}{2} = \frac{y-3}{-1} = \frac{z-4}{1} = k \quad [\text{say}]$$

Any point in this normal is $(2k+1, -k+3, 4+k)$.

Then, $\left(\frac{2k+1+1}{2}, \frac{3-k+3}{2}, \frac{4+k+4}{2}\right)$ lies on plane.

$$\Rightarrow 2(k+1) - \left(\frac{6-k}{2}\right) + \left(\frac{8+k}{2}\right) + 3 = 0 \Rightarrow k = -2$$

Hence, point through which this image pass is

$$(2k+1, 3-k, 4+k)$$

i.e. $[2(-2)+1, 3+2, 4-2] = (-3, 5, 2)$

Hence, equation of image line is $\frac{x+3}{3} = \frac{y-5}{1} = \frac{z-2}{-5}$.

41. **Key Idea** To find the foot of perpendiculars and find its locus.

Formula used

Foot of perpendicular from (x_1, y_1, z_1) to $ax + by + cz + d = 0$ be (x_2, y_2, z_2) , then

$$\frac{x_2 - x_1}{a} = \frac{y_2 - y_1}{b} = \frac{z_2 - z_1}{c} = \frac{-(ax_1 + by_1 + cz_1 + d)}{a^2 + b^2 + c^2}$$

Any point on $\frac{x+2}{2} = \frac{y+1}{-1} = \frac{z}{3} = \lambda$

$$\Rightarrow x = 2\lambda - 2, y = -\lambda - 1, z = 3\lambda$$

Let foot of perpendicular from $(2\lambda - 2, -\lambda - 1, 3\lambda)$

to $x + y + z = 3$ be (x_2, y_2, z_2) .

$$\begin{aligned} \therefore \frac{x_2 - (2\lambda - 2)}{1} &= \frac{y_2 - (-\lambda - 1)}{1} = \frac{z_2 - (3\lambda)}{1} \\ &= -\frac{(2\lambda - 2 - \lambda - 1 + 3\lambda - 3)}{1 + 1 + 1} \end{aligned}$$

$$\Rightarrow x_2 - 2\lambda + 2 = y_2 + \lambda + 1 = z_2 - 3\lambda = 2 - \frac{4\lambda}{3}$$

$$\therefore x_2 = \frac{2\lambda}{3}, y_2 = 1 - \frac{7\lambda}{3}, z_2 = 2 + \frac{5\lambda}{3}$$

$$\Rightarrow \lambda = \frac{x_2 - 0}{2/3} = \frac{y_2 - 1}{-7/3} = \frac{z_2 - 2}{5/3}$$

Hence, foot of perpendicular lie on

$$\frac{x}{2/3} = \frac{y-1}{-7/3} = \frac{z-2}{5/3} \Rightarrow \frac{x}{2} = \frac{y-1}{-7} = \frac{z-2}{5}$$

42. Given planes are

$$2x + y + 2z - 8 = 0 \text{ and } 2x + y + 2z + \frac{5}{2} = 0$$

\therefore Distance between two planes

$$= \frac{|c_1 - c_2|}{\sqrt{a^2 + b^2 + c^2}} = \frac{\left| -8 - \frac{5}{2} \right|}{\sqrt{2^2 + 1^2 + 2^2}} = \frac{21/2}{3} = \frac{7}{2}$$

43. **Key Idea**

(i) Equation of plane through intersection of two planes, i.e. $(a_1x + b_1y + c_1z + d_1) + \lambda$

$$(a_2x + b_2y + c_2z + d_2) = 0$$

(ii) Distance of a point (x_1, y_1, z_1) from

$$ax + by + cz + d = 0$$

$$= \frac{|ax_1 + by_1 + cz_1 + d|}{\sqrt{a^2 + b^2 + c^2}}$$

Equation of plane passing through intersection of two planes $x + 2y + 3z = 2$ and $x - y + z = 3$ is

$$(x + 2y + 3z - 2) + \lambda(x - y + z - 3) = 0$$

$$\Rightarrow (1 + \lambda)x + (2 - \lambda)y + (3 + \lambda)z - (2 + 3\lambda) = 0$$

whose distance from $(3, 1, -1)$ is $\frac{2}{\sqrt{3}}$.

$$\Rightarrow \frac{|3(1 + \lambda) + 1 \cdot (2 - \lambda) - 1(3 + \lambda) - (2 + 3\lambda)|}{\sqrt{(1 + \lambda)^2 + (2 - \lambda)^2 + (3 + \lambda)^2}} = \frac{2}{\sqrt{3}}$$

$$\Rightarrow \frac{|-2\lambda|}{\sqrt{3\lambda^2 + 4\lambda + 14}} = \frac{2}{\sqrt{3}}$$

$$\Rightarrow 3\lambda^2 = 3\lambda^2 + 4\lambda + 14$$

$$\Rightarrow \lambda = -\frac{7}{2}$$

$$\therefore \left(1 - \frac{7}{2}\right)x + \left(2 + \frac{7}{2}\right)y + \left(3 - \frac{7}{2}\right)z - \left(2 - \frac{21}{2}\right) = 0$$

$$\Rightarrow -\frac{5x}{2} + \frac{11y}{2} - \frac{1z}{2} + \frac{17}{2} = 0$$

or

$$5x - 11y + z - 17 = 0$$

44. **PLAN** It is based on two concepts one is intersection of straight line and plane and other is the foot of perpendicular from a point to the straight line.

Description of Situation

(i) If the straight line

$$\frac{x-x_1}{a} = \frac{y-y_1}{b} = \frac{z-z_1}{c} = \lambda$$

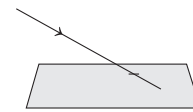

intersects the plane $Ax + By + Cz + d = 0$.

Then, $(a\lambda + x_1, b\lambda + y_1, c\lambda + z_1)$ would satisfy

$$Ax + By + Cz + d = 0$$

(ii) If A is the foot of perpendicular from P to l .

Then, (DR's of PA) is perpendicular to DR's of l .

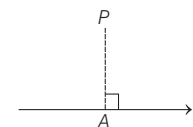

$$\Rightarrow \overline{PA} \cdot \vec{l} = 0$$

Equation of straight line QR , is

$$\frac{x-2}{1-2} = \frac{y-3}{-1-3} = \frac{z-5}{4-5}$$

600 3D Geometry

$$\Rightarrow \frac{x-2}{-1} = \frac{y-3}{-4} = \frac{z-5}{-1}$$

$$\Rightarrow \frac{x-2}{1} = \frac{y-3}{4} = \frac{z-5}{1} = \lambda \quad \dots(i)$$

$\therefore P(\lambda + 2, 4\lambda + 3, \lambda + 5)$ must lie on $5x - 4y - z = 1$.

$$\Rightarrow 5(\lambda + 2) - 4(4\lambda + 3) - (\lambda + 5) = 1$$

$$\Rightarrow 5\lambda + 10 - 16\lambda - 12 - \lambda - 5 = 1$$

$$\Rightarrow -7 - 12\lambda = 1$$

$$\therefore \lambda = \frac{-2}{3}$$

or $P\left(\frac{4}{3}, \frac{1}{3}, \frac{13}{3}\right)$

Again, we can assume S from Eq.(i),
 as $S(\mu + 2, 4\mu + 3, \mu + 5)$
 \therefore DR's of $TS = \langle \mu + 2 - 2, 4\mu + 3 - 1, \mu + 5 - 4 \rangle$
 $= \langle \mu, 4\mu + 2, \mu + 1 \rangle$
 and DR's of $QR = \langle 1, 4, 1 \rangle$
 Since, perpendicular
 $\therefore 1(\mu) + 4(4\mu + 2) + 1(\mu + 1) = 0$
 $\Rightarrow \mu = -\frac{1}{2}$ and $S\left(\frac{3}{2}, 1, \frac{9}{2}\right)$

$$\therefore \text{Length of } PS = \sqrt{\left(\frac{3}{2} - \frac{4}{3}\right)^2 + \left(1 - \frac{1}{3}\right)^2 + \left(\frac{9}{2} - \frac{13}{3}\right)^2} = \frac{1}{\sqrt{2}}$$

45. Distance of point P from plane = 5

$$\therefore 5 = \left| \frac{1 - 4 - 2 - \alpha}{3} \right|$$

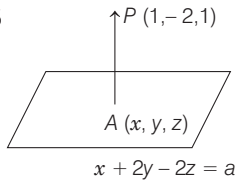
$$\Rightarrow \alpha = 10$$

Foot of perpendicular

$$\frac{x-1}{1} = \frac{y+2}{2} = \frac{z-1}{-2} = \frac{5}{3}$$

$$\Rightarrow x = \frac{8}{3}, y = \frac{4}{3}, z = -\frac{7}{3}$$

Thus, the foot of the perpendicular is $A\left(\frac{8}{3}, \frac{4}{3}, -\frac{7}{3}\right)$.

46. The DR's of normal to the plane containing $\frac{x}{3} = \frac{y}{4} = \frac{z}{2}$
 and $\frac{x}{4} = \frac{y}{z} = \frac{z}{3}$.

$$\mathbf{n}_1 = \begin{vmatrix} \hat{i} & \hat{j} & \hat{k} \\ 3 & 4 & 2 \\ 4 & 2 & 3 \end{vmatrix} = (8\hat{i} - \hat{j} - 10\hat{k})$$

$n(a, b, c)$

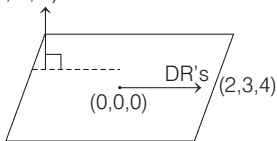

Also, equation of plane containing $\frac{x}{2} = \frac{y}{3} = \frac{z}{4}$ and DR's of normal to be $\mathbf{n}_1 = a\hat{i} + b\hat{j} + c\hat{k}$

$$\Rightarrow ax + by + cz = 0 \quad \dots(i)$$

where, $\mathbf{n}_1 \cdot \mathbf{n}_2 = 0$

$$\Rightarrow 8a - b - 10c = 0 \quad \dots(ii)$$

and $\mathbf{n}_2 \perp (2\hat{i} + 3\hat{j} + 4\hat{k})$

$$\Rightarrow 2a + 3b + 4c = 0 \quad \dots(iii)$$

From Eqs (ii) and (iii),

$$\frac{a}{-4 + 30} = \frac{b}{-20 - 32} = \frac{c}{24 + 2}$$

$$\Rightarrow \frac{a}{26} = \frac{b}{-52} = \frac{c}{26}$$

$$\Rightarrow \frac{a}{1} = \frac{b}{-2} = \frac{c}{1} \quad \dots(iv)$$

From Eqs. (i) and (iv), required equation of plane is $x - 2y + z = 0$

47. Since, $l = m = n = \frac{1}{\sqrt{3}}$

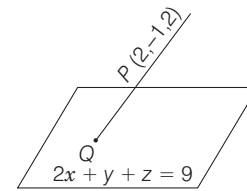

$$\therefore \text{Equations of line are } \frac{x-2}{1/\sqrt{3}} = \frac{y+1}{1/\sqrt{3}} = \frac{z-2}{1/\sqrt{3}}$$

$$\Rightarrow x - 2 = y + 1 = z - 2 = r \quad [\text{say}]$$

\therefore Any point on the line is

$$Q \equiv (r + 2, r - 1, r + 2)$$

$\therefore Q$ lies on the plane $2x + y + z = 9$

$$\therefore 2(r + 2) + (r - 1) + (r + 2) = 9$$

$$\Rightarrow 4r + 5 = 9 \Rightarrow r = 1$$

$$\Rightarrow Q(3, 0, 3)$$

$$\therefore PQ = \sqrt{(3-2)^2 + (0+1)^2 + (3-2)^2} = \sqrt{3}$$

48. Given, $\mathbf{OQ} = (1 - 3\mu)\hat{i} + (\mu - 1)\hat{j} + (5\mu + 2)\hat{k}$
 and $\mathbf{OP} = 3\hat{i} + 2\hat{j} + 6\hat{k}$ [where, O is origin]

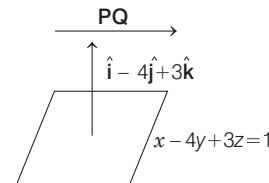

Now, $\mathbf{PQ} = (1 - 3\mu - 3)\hat{i} + (\mu - 1 - 2)\hat{j} + (5\mu + 2 - 6)\hat{k}$
 $= (-2 - 3\mu)\hat{i} + (\mu - 3)\hat{j} + (5\mu - 4)\hat{k}$

$\therefore \mathbf{PQ}$ is parallel to the plane $x - 4y + 3z = 1$.

$$\therefore -2 - 3\mu - 4\mu + 12 + 15\mu - 12 = 0$$

$$\Rightarrow 8\mu = 2 \Rightarrow \mu = \frac{1}{4}$$

49. Let the equation of plane be

$$a(x-1) + b(y+2) + c(z-1) = 0$$

which is perpendicular to $2x-2y+z=0$ and $x-y+2z=4$.

$$\Rightarrow 2a-2b+c=0 \text{ and } a-b+2c=0$$

$$\Rightarrow \frac{a}{-3} = \frac{b}{-3} = \frac{c}{0}$$

$$\Rightarrow \frac{a}{1} = \frac{b}{1} = \frac{c}{0}$$

So, the equation of plane is $x-1+y+2=0$

$$\text{or } x+y+1=0$$

Its distance from the point $(1, 2, 2)$ is $\frac{|1+2+1|}{\sqrt{2}} = 2\sqrt{2}$

50. Since, $\frac{x}{a} + \frac{y}{b} + \frac{z}{c} = 1$ cuts the coordinate axes at $A(a, 0, 0), B(0, b, 0), C(0, 0, c)$.

And its distance from origin = 1

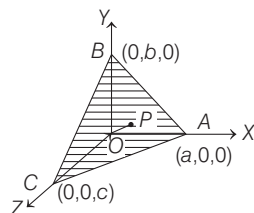

$$\therefore \frac{1}{\sqrt{\frac{1}{a^2} + \frac{1}{b^2} + \frac{1}{c^2}}} = 1$$

$$\text{or } \frac{1}{a^2} + \frac{1}{b^2} + \frac{1}{c^2} = 1 \quad \dots(i)$$

where, P is centroid of triangle.

$$\therefore P(x, y, z) = \left(\frac{a+0+0}{3}, \frac{0+b+0}{3}, \frac{0+0+c}{3} \right)$$

$$\Rightarrow x = \frac{a}{3}, y = \frac{b}{3}, z = \frac{c}{3} \quad \dots(ii)$$

From Eqs. (i) and (ii),

$$\frac{1}{9x^2} + \frac{1}{9y^2} + \frac{1}{9z^2} = 1$$

$$\text{or } \frac{1}{x^2} + \frac{1}{y^2} + \frac{1}{z^2} = 9 = K$$

$$\therefore K = 9$$

51. Given equation of straight line

$$\frac{x-4}{1} = \frac{y-2}{1} = \frac{z-k}{2}$$

Since, the line lies in the plane $2x-4y+z=7$.

Hence, point $(4, 2, k)$ must satisfy the plane.

$$\Rightarrow 8-8+k=7 \Rightarrow k=7$$

52. Since, the point $A(3, 2, -1)$ is the mirror image of the point $B(1, 0, -1)$ with respect to the plane $\alpha x + \beta y + \gamma z = \delta$, then

$$\frac{\alpha}{3-1} = \frac{\beta}{2-0} = \frac{\gamma}{(-1)-(-1)}$$

$$\Rightarrow \frac{\alpha}{1} = \frac{\beta}{1} = \frac{\gamma}{0}$$

$$\Rightarrow \gamma = 0$$

it is given that $\alpha + \gamma = 1$

$$\Rightarrow \alpha = 1, \text{ so } \beta = 1.$$

And, the mid-point of $AB, M(2, 1, -1)$ lies on the given plane, so

$$2\alpha + \beta - \gamma = \delta$$

$$\Rightarrow 2(1) + (1) - 0 = \delta$$

$$\Rightarrow \delta = 3$$

$$\therefore \alpha + \beta = 2, \delta - \gamma = 0, \delta + \beta = 4.$$

53. Given, square base $OP = OR = 3$

$$\therefore P(3, 0, 0), R(0, 3, 0)$$

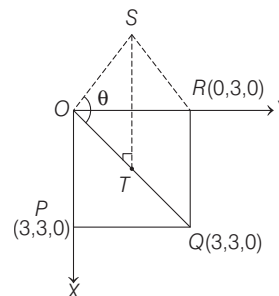

Also, mid-point of OQ is $T\left(\frac{3}{2}, \frac{3}{2}, 0\right)$.

Since, S is directly above the mid-point T of diagonal OQ and $ST = 3$.

$$\text{i.e. } S\left(\frac{3}{2}, \frac{3}{2}, 3\right)$$

Here, DR's of $OQ(3, 3, 0)$ and DR's of $OS\left(\frac{3}{2}, \frac{3}{2}, 3\right)$.

$$\therefore \cos \theta = \frac{\frac{9}{2} + \frac{9}{2}}{\sqrt{9+9+0} \sqrt{\frac{9}{4} + \frac{9}{4} + 9}} = \frac{9}{\sqrt{18} \cdot \sqrt{\frac{27}{2}}} = \frac{1}{\sqrt{3}}$$

\therefore Option (a) is incorrect.

Now, equation of the plane containing the ΔOQS is

$$\begin{vmatrix} x & y & z \\ 3 & 3 & 0 \\ 3/2 & 3/2 & 3 \end{vmatrix} = 0 \Rightarrow \begin{vmatrix} x & y & z \\ 1 & 1 & 0 \\ 1 & 1 & 2 \end{vmatrix} = 0$$

$$\Rightarrow x(2-0) - y(2-0) + z(1-1) = 0$$

$$\Rightarrow 2x - 2y = 0 \text{ or } x - y = 0$$

\therefore Option (b) is correct.

Now, length of the perpendicular from $P(3, 0, 0)$ to the plane containing ΔOQS is $\frac{|3-0|}{\sqrt{1+1}} = \frac{3}{\sqrt{2}}$

\therefore Option (c) is correct.

602 3D Geometry

Here, equation of RS is

$$\frac{x-0}{3/2} = \frac{y-3}{-3/2} = \frac{z-0}{3} = \lambda$$

$$\Rightarrow x = \frac{3}{2}\lambda, y = -\frac{3}{2}\lambda + 3, z = 3\lambda$$

To find the distance from $O(0, 0, 0)$ to RS .

Let M be the foot of perpendicular.

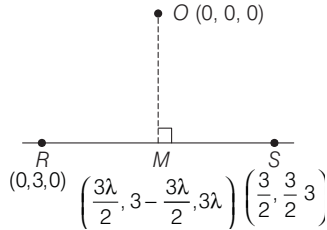

$$\therefore \overline{OM} \perp \overline{RS} \Rightarrow \overline{OM} \cdot \overline{RS} = 0$$

$$\Rightarrow \frac{9\lambda}{4} - \frac{3}{2} \left(3 - \frac{3\lambda}{2} \right) + 3(3\lambda) = 0 \Rightarrow \lambda = \frac{1}{3}$$

$$\therefore M \left(\frac{1}{2}, \frac{5}{2}, 1 \right) \Rightarrow OM = \sqrt{\frac{1}{4} + \frac{25}{4} + 1} = \sqrt{\frac{30}{4}} = \frac{\sqrt{15}}{2}$$

\therefore Option (d) is correct.

54. Here, $P_3 : (x + z - 1) + \lambda y = 0$

i.e. $P_3 : x + \lambda y + z - 1 = 0 \quad \dots(i)$

whose distance from $(0, 1, 0)$ is 1.

$$\therefore \frac{|0 + \lambda + 0 - 1|}{\sqrt{1 + \lambda^2 + 1}} = 1$$

$$\Rightarrow |\lambda - 1| = \sqrt{\lambda^2 + 2}$$

$$\Rightarrow \lambda^2 - 2\lambda + 1 = \lambda^2 + 2 \Rightarrow \lambda = -\frac{1}{2}$$

\therefore Equation of P_3 is $2x - y + 2z - 2 = 0$.

\therefore Distance from (α, β, γ) is 2.

$$\therefore \frac{|2\alpha - \beta + 2\gamma - 2|}{\sqrt{4 + 1 + 4}} = 2$$

$$\Rightarrow 2\alpha - \beta + 2\gamma - 2 = \pm 6$$

$$\Rightarrow 2\alpha - \beta + 2\gamma = 8 \quad \text{and} \quad 2\alpha - \beta + 2\gamma = -4$$

55. Since, L is at constant distance from two planes P_1 and P_2 .

Therefore, L is parallel to the line through intersection of P_1 and P_2 .

$$\begin{aligned} \text{DR's of } L &= \begin{vmatrix} \hat{i} & \hat{j} & \hat{k} \\ 1 & 2 & -1 \\ 2 & -1 & 1 \end{vmatrix} \\ &= \hat{i}(2-1) - \hat{j}(1+2) + \hat{k}(-1-4) = \hat{i} - 3\hat{j} - 5\hat{k} \end{aligned}$$

\therefore DR's of L are $(1, -3, -5)$ passing through $(0, 0, 0)$.

Now, equation of L is

$$\frac{x-0}{1} = \frac{y-0}{-3} = \frac{z-0}{-5}$$

For any point on L , $\frac{x}{1} = \frac{y}{-3} = \frac{z}{-5} = \lambda \quad [\text{say}]$

i.e. $P(\lambda, -3\lambda, -5\lambda)$

If (α, β, γ) is foot of perpendicular from P on P_1 , then

$$\frac{\alpha - \lambda}{1} = \frac{\beta + 3\lambda}{2} = \frac{\gamma + 5\lambda}{-1} = k \quad [\text{say}]$$

$$\Rightarrow \alpha = \lambda + k, \beta = 2k - 3\lambda, \gamma = -k - 5\lambda$$

which satisfy $P_1: x + 2y - z + 1 = 0$

$$\Rightarrow (\lambda + k) + 2(2k - 3\lambda) - (-k - 5\lambda) + 1 = 0$$

$$\Rightarrow k = -\frac{1}{6}$$

$$\therefore x = -\frac{1}{6} + \lambda, y = -\frac{1}{3} - 3\lambda, z = \frac{1}{6} - 5\lambda$$

which satisfy options (a) and (b).

56. We have,

$$P_1 : 2x + y - z = 3$$

and $P_2 : x + 2y + z = 2$

Here, $\vec{n}_1 = 2\hat{i} + \hat{j} - \hat{k}$

and $\vec{n}_2 = \hat{i} + 2\hat{j} + \hat{k}$

(a) Direction ratio of the line of intersection of P_1

and P_2 is $\theta \vec{n}_1 \times \vec{n}_2$

$$\begin{aligned} \text{i.e. } \begin{vmatrix} \hat{i} & \hat{j} & \hat{k} \\ 2 & 1 & -1 \\ 1 & 2 & 1 \end{vmatrix} &= (1+2)\hat{i} - (2+1)\hat{j} + (4-1)\hat{k} \\ &= 3(\hat{i} - \hat{j} + \hat{k}) \end{aligned}$$

Hence, statement a is false.

(b) We have, $\frac{3x-4}{9} = \frac{1-3y}{9} = \frac{z}{3} \Rightarrow \frac{x-\frac{4}{3}}{3} = \frac{y-\frac{1}{3}}{-3} = \frac{z}{3}$

This line is parallel to the line of intersection of P_1 and P_2 .

Hence, statement (b) is false.

(c) Let acute angle between P_1 and P_2 be θ .

We know that,

$$\begin{aligned} \cos \theta &= \frac{|\vec{n}_1 \cdot \vec{n}_2|}{|\vec{n}_1| |\vec{n}_2|} = \frac{|(2\hat{i} + \hat{j} - \hat{k}) \cdot (\hat{i} + 2\hat{j} + \hat{k})|}{|\vec{n}_1| |\vec{n}_2|} \\ &= \frac{2+2-1}{\sqrt{6} \times \sqrt{6}} = \frac{1}{2} \end{aligned}$$

$$\theta = 60^\circ$$

Hence, statement (c) is true.

(d) Equation of plane passing through the point $(4, 2, -2)$ and perpendicular to the line of intersection of P_1 and P_2 is

$$3(x-4) - 3(y-2) + 3(z+2) = 0$$

$$\Rightarrow 3x - 3y + 3z - 12 + 6 + 6 = 0$$

$$\Rightarrow x - y + z = 0$$

Now, distance of the point $(2, 1, 1)$ from the plane

$x - y + z = 0$ is

$$D = \frac{|2 - 1 + 1|}{\sqrt{1 + 1 + 1}} = \frac{2}{\sqrt{3}}$$

Hence, statement (d) is true.

- 57. PLAN** If the straight lines are coplanar. They should lie in same plane.

Description of Situation If straight lines are coplanar.

$$\Rightarrow \begin{vmatrix} x_2 - x_1 & y_2 - y_1 & z_2 - z_1 \\ a_1 & b_1 & c_1 \\ a_2 & b_2 & c_2 \end{vmatrix} = 0$$

Since, $\frac{x-1}{2} = \frac{y+1}{K} = \frac{z}{2}$

and $\frac{x+1}{5} = \frac{y+1}{2} = \frac{z}{k}$ are coplanar.

$$\Rightarrow \begin{vmatrix} 2 & 0 & 0 \\ 2 & K & 2 \\ 5 & 2 & K \end{vmatrix} = 0 \Rightarrow K^2 = 4 \Rightarrow K = \pm 2$$

$\therefore \mathbf{n}_1 = \mathbf{b}_1 \times \mathbf{d}_1 = 6\mathbf{j} - 6\mathbf{k}$, for $k = 2$

$\therefore \mathbf{n}_2 = \mathbf{b}_2 \times \mathbf{d}_2 = 14\mathbf{j} + 14\mathbf{k}$, for $k = -2$

So, equation of planes are $(\mathbf{r} - \mathbf{a}) \cdot \mathbf{n}_1 = 0$

$$\Rightarrow y - z = -1 \quad \text{and} \quad (\mathbf{r} - \mathbf{a}) \cdot \mathbf{n}_2 = 0$$

$$\Rightarrow y + z = -1$$

- 58.** Given three lines

$$\mathbf{r} = \lambda \hat{\mathbf{i}}, \lambda \in R,$$

$$\mathbf{r} = \mu(\hat{\mathbf{i}} + \hat{\mathbf{j}}), \mu \in R$$

and $\mathbf{r} = \nu(\hat{\mathbf{i}} + \hat{\mathbf{j}} + \hat{\mathbf{k}}), \nu \in R$

cuts the plane $x + y + z = 1$ at the points A, B and C , respectively. So, for point A , put $(\lambda, 0, 0)$ in the plane, we get $\lambda + 0 + 0 = 1 \Rightarrow \lambda = 1 \Rightarrow A \equiv (1, 0, 0)$. Similarly, for point B , put $(\mu, \mu, 0)$ in the plane, we get $\mu + \mu + 0 = 1 \Rightarrow \mu = \frac{1}{2} \Rightarrow B \equiv \left(\frac{1}{2}, \frac{1}{2}, 0\right)$.

and for point C , put (ν, ν, ν) in the plane we get $\nu + \nu + \nu = 1$

$$\Rightarrow \nu = \frac{1}{3} \Rightarrow C \equiv \left(\frac{1}{3}, \frac{1}{3}, \frac{1}{3}\right)$$

Now, area of $\Delta ABC = \frac{1}{2} |\overrightarrow{AB} \times \overrightarrow{AC}| = \Delta$

$\therefore \mathbf{AB} = -\frac{1}{2}\hat{\mathbf{i}} + \frac{1}{2}\hat{\mathbf{j}}$, and

$$\mathbf{AC} = -\frac{2}{3}\hat{\mathbf{i}} + \frac{1}{3}\hat{\mathbf{j}} + \frac{1}{3}\hat{\mathbf{k}}$$

$$\therefore \mathbf{AB} \times \mathbf{AC} = \begin{vmatrix} \hat{\mathbf{i}} & \hat{\mathbf{j}} & \hat{\mathbf{k}} \\ -\frac{1}{2} & \frac{1}{2} & 0 \\ -\frac{2}{3} & \frac{1}{3} & \frac{1}{3} \end{vmatrix}$$

$$= \hat{\mathbf{i}}\left(\frac{1}{6}\right) - \hat{\mathbf{j}}\left(-\frac{1}{6}\right) + \hat{\mathbf{k}}\left(-\frac{1}{6} + \frac{2}{6}\right) = \frac{1}{6}(\hat{\mathbf{i}} + \hat{\mathbf{j}} + \hat{\mathbf{k}})$$

$$\Rightarrow |\mathbf{AB} \times \mathbf{AC}| = \frac{1}{6} \sqrt{3} = \frac{1}{2\sqrt{3}}$$

$$\Rightarrow \Delta = \frac{1}{4\sqrt{3}}$$

$$\Rightarrow (6\Delta)^2 = 36 \frac{1}{16 \times 3} = \frac{3}{4} = 0.75$$

- 59.** Let $P(\alpha, \beta, \gamma)$ and R is image of P in the xy -plane.

$$\therefore R(\alpha, \beta, -\gamma)$$

Also, Q is the image of P in the plane $x + y = 3$

$$\therefore \frac{x-\alpha}{1} = \frac{y-\beta}{1} = \frac{z-\gamma}{0} = \frac{-2(\alpha+\beta-3)}{2}$$

$$x = 3 - \beta, y = 3 - \alpha, z = \gamma$$

Since, Q is lies on Z -axis

$$\therefore \beta = 3, \alpha = 3, z = \gamma$$

$$\therefore P(3, 3, \gamma)$$

Given, distance of P from X -axis be 5.

$$\therefore 5 = \sqrt{3^2 + \gamma^2}$$

$$25 - 9 = \gamma^2 \Rightarrow \gamma = \pm 4$$

Then, $PR = |\gamma| = |2 \times 4| = 8$

- 60.** The equation of the plane passing through the point $(-1, -2, -1)$ and whose normal is perpendicular to both the given lines L_1 and L_2 may be written as

$$(x+1) + 7(y+2) - 5(z+1) = 0 \Rightarrow x + 7y - 5z + 10 = 0$$

The distance of the point $(1, 1, 1)$ from the plane

$$= \frac{|1 + 7 - 5 + 10|}{\sqrt{1 + 49 + 25}} = \frac{13}{\sqrt{75}} \text{ units}$$

- 61.** The shortest distance between L_1 and L_2 is

$$\left| \frac{\{(2 - (-1))\hat{\mathbf{i}} + (2 - 2)\hat{\mathbf{j}} + (3 - (-1))\hat{\mathbf{k}}\} \cdot (-\hat{\mathbf{i}} - 7\hat{\mathbf{j}} + 5\hat{\mathbf{k}})}{5\sqrt{3}} \right|$$

$$= \left| \frac{(3\hat{\mathbf{i}} + 4\hat{\mathbf{k}}) \cdot (-\hat{\mathbf{i}} - 7\hat{\mathbf{j}} + 5\hat{\mathbf{k}})}{5\sqrt{3}} \right| = \frac{17}{5\sqrt{3}} \text{ units}$$

- 62.** The equations of given lines in vector form may be written as $L_1: \vec{r} = (-\hat{\mathbf{i}} - 2\hat{\mathbf{j}} - \hat{\mathbf{k}}) + \lambda(3\hat{\mathbf{i}} + \hat{\mathbf{j}} + 2\hat{\mathbf{k}})$

and $L_2: \vec{r} = (2\hat{\mathbf{i}} - 2\hat{\mathbf{j}} + 3\hat{\mathbf{k}}) + \mu(\hat{\mathbf{i}} + 2\hat{\mathbf{j}} + 3\hat{\mathbf{k}})$

Since, the vector is perpendicular to both L_1 and L_2 .

$$\begin{vmatrix} \hat{\mathbf{i}} & \hat{\mathbf{j}} & \hat{\mathbf{k}} \\ 3 & 1 & 2 \\ 1 & 2 & 3 \end{vmatrix} = -\hat{\mathbf{i}} - 7\hat{\mathbf{j}} + 5\hat{\mathbf{k}}$$

\therefore Required unit vector

$$= \frac{(-\hat{\mathbf{i}} - 7\hat{\mathbf{j}} + 5\hat{\mathbf{k}})}{\sqrt{(-1)^2 + (-7)^2 + (5)^2}} = \frac{1}{5\sqrt{3}}(-\hat{\mathbf{i}} - 7\hat{\mathbf{j}} + 5\hat{\mathbf{k}})$$

- 63.** Given three planes are

$$P_1: x - y + z = 1 \quad \dots(i)$$

$$P_2: x + y - z = -1 \quad \dots(ii)$$

and $P_3: x - 3y + 3z = 2 \quad \dots(iii)$

On solving Eqs. (i) and (ii), we get

$$x = 0, z = 1 + y$$

which does not satisfy Eq. (iii).

As $x - 3y + 3z = 0 - 3y + 3(1 + y) = 3 (\neq 2)$

So, Statement II is true.

604 3D Geometry

Next, since we know that direction ratios of line of intersection of planes $a_1x + b_1y + c_1z + d_1 = 0$

and $a_2x + b_2y + c_2z + d_2 = 0$ is

$$b_1c_2 - b_2c_1, c_1a_2 - a_1c_2, a_1b_2 - a_2b_1$$

Using above result,

Direction ratios of lines L_1, L_2 and L_3 are

$$0, 2, 2; 0, -4, -4; 0, -2, -2$$

Since, all the three lines L_1, L_2 and L_3 are parallel pairwise.

Hence, Statement I is false.

64. Given planes are $3x - 6y - 2z = 15$ and $2x + y - 2z = 5$.

For $z = 0$, we get $x = 3, y = -1$

Since, direction ratios of planes are

$$\langle 3, -6, -2 \rangle \text{ and } \langle 2, 1, -2 \rangle$$

Then the DR's of line of intersection of planes is $\langle 14, 2, 15 \rangle$ and line is

$$\frac{x-3}{14} = \frac{y+1}{2} = \frac{z-0}{15} = \lambda \quad [\text{say}]$$

$$\Rightarrow x = 14\lambda + 3, y = 2\lambda - 1, z = 15\lambda$$

Hence, Statement I is false.

But Statement II is true.

65. $L_1: \frac{x-1}{2} = \frac{y-0}{-1} = \frac{z-(-3)}{1}$

$$\text{Normal of plane } P: \mathbf{n} = \begin{vmatrix} \hat{\mathbf{i}} & \hat{\mathbf{j}} & \hat{\mathbf{k}} \\ 7 & 1 & 2 \\ 3 & 5 & -6 \end{vmatrix}$$

$$= \hat{\mathbf{i}}(-16) - \hat{\mathbf{j}}(-42 - 6) + \hat{\mathbf{k}}(32) = -16\hat{\mathbf{i}} + 48\hat{\mathbf{j}} + 32\hat{\mathbf{k}}$$

DR's of normal $\mathbf{n} = \hat{\mathbf{i}} - 3\hat{\mathbf{j}} - 2\hat{\mathbf{k}}$

Point of intersection of L_1 and L_2 .

$$\Rightarrow 2K_1 + 1 = K_2 + 4$$

$$\text{and } -k_1 = k_2 - 3 \Rightarrow k_1 = 2 \text{ and } k_2 = 1$$

\therefore Point of intersection $(5, -2, -1)$

Now equation of plane,

$$1 \cdot (x-5) - 3(y+2) - 2(z+1) = 0$$

$$\Rightarrow x - 3y - 2z - 13 = 0$$

$$\Rightarrow x - 3y - 2z = 13$$

$$\therefore a \rightarrow 1, b \rightarrow -3, c \rightarrow -2, d \rightarrow 13$$

66. Let $\Delta = \begin{vmatrix} a & b & c \\ b & c & a \\ c & a & b \end{vmatrix}$

$$= -\frac{1}{2} (a+b+c) [(a-b)^2 + (b-c)^2 + (c-a)^2]$$

A. If $a+b+c \neq 0$ and $a^2+b^2+c^2 = ab+bc+ca$

$$\Rightarrow \Delta = 0$$

and $a = b = c \neq 0$

\Rightarrow The equations represent identical planes.

B. $a+b+c=0$ and $a^2+b^2+c^2 \neq ab+bc+ca$

$$\Rightarrow \Delta = 0$$

\Rightarrow The equations have infinitely many solutions.

$$ax + by = (a+b)z, \quad bx + cy = (b+c)z$$

$$\Rightarrow (b^2 - ac)y = (b^2 - ac)z \Rightarrow y = z$$

$$\Rightarrow ax + by + cy = 0$$

$$\Rightarrow ax = ay \Rightarrow x = y = z$$

C. $a+b+c \neq 0$ and $a^2+b^2+c^2 \neq ab+bc+ca$

$$\Rightarrow \Delta \neq 0$$

The equations represent planes meeting at only one point.

D. $a+b+c=0$ and $a^2+b^2+c^2 = ab+bc+ca$

$$\Rightarrow a = b = c = 0$$

\Rightarrow The equations represent whole of the three-dimensional space.

67. Equation of plane containing the lines

$$2x - y + z - 3 = 0 \text{ and } 3x + y + z = 5 \text{ is}$$

$$(2x - y + z - 3) + \lambda(3x + y + z - 5) = 0$$

$$\Rightarrow (2 + 3\lambda)x + (\lambda - 1)y + (\lambda + 1)z - 3 - 5\lambda = 0$$

Since, distance of plane from $(2, 1, -1)$ to above plane is $1/\sqrt{6}$.

$$\therefore \frac{|6\lambda + 4 + \lambda - 1 - \lambda - 1 - 3 - 5\lambda|}{\sqrt{(3\lambda + 2)^2 + (\lambda - 1)^2 + (\lambda + 1)^2}} = \frac{1}{\sqrt{6}}$$

$$\Rightarrow 6(\lambda - 1)^2 = 11\lambda^2 + 12\lambda + 6$$

$$\Rightarrow \lambda = 0, -\frac{24}{5}$$

\therefore Equations of planes are

$$2x - y + z - 3 = 0 \text{ and } 62x + 29y + 19z - 105 = 0$$

68. Let the equation of plane through $(1, 1, 1)$ having a, b, c as DR's of normal to plane,

$$a(x-1) + b(y-1) + c(z-1) = 0$$

and plane is parallel to straight line having DR's.

$$(1, 0, -1) \text{ and } (-1, 1, 0)$$

$$\Rightarrow a - c = 0$$

$$\text{and } -a + b = 0$$

$$\Rightarrow a = b = c$$

\therefore Equation of plane is

$$x - 1 + y - 1 + z - 1 = 0$$

$$\text{or } \frac{x}{3} + \frac{y}{3} + \frac{z}{3} = 1.$$

Its intercept on coordinate axes are

$$A(3, 0, 0), B(0, 3, 0), C(0, 0, 3).$$

Hence, the volume of tetrahedron $OABC$

$$= \frac{1}{6} [\mathbf{a} \ \mathbf{b} \ \mathbf{c}] = \frac{1}{6} \begin{vmatrix} 3 & 0 & 0 \\ 0 & 3 & 0 \\ 0 & 0 & 3 \end{vmatrix} = \frac{27}{6} = \frac{9}{2} \text{ cu units}$$

69. Let the equation of the plane $ABCD$ be $ax + by + cz + d = 0$, the point A' be (α, β, γ) and the height of the parallelepiped $ABCD$ be h .

$$\Rightarrow \frac{|\alpha a + \beta b + \gamma c + d|}{\sqrt{a^2 + b^2 + c^2}} = 90\% h$$

$$\Rightarrow \alpha a + \beta b + \gamma c + d = \pm 0.9 h \sqrt{a^2 + b^2 + c^2}$$

$$\therefore \text{Locus is } ax + by + cz + d = \pm 0.9 h \sqrt{a^2 + b^2 + c^2}$$

Hence, locus of A'' is a plane parallel to the plane $ABCD$.

70. (i) Equation of plane passing through $(2, 1, 0)$ is

$$a(x-2) + b(y-1) + c(z-0) = 0$$

It also passes through $(5, 0, 1)$ and $(4, 1, 1)$.

$$\Rightarrow 3a - b + c = 0 \text{ and } 2a - 0b + c = 0$$

$$\text{On solving, we get } \frac{a}{-1} = \frac{b}{-1} = \frac{c}{2}$$

\therefore Equation of plane is

$$-(x-2) - (y-1) + 2(z-0) = 0$$

$$-(x-2) - y + 1 + 2z = 0$$

$$\Rightarrow x + y - 2z = 3$$

- (ii) Let the coordinates of Q be (α, β, γ) .

$$\text{Equation of line } PQ \Rightarrow \frac{x-2}{1} = \frac{y-1}{1} = \frac{z-6}{-2}$$

Since, mid-point of P and Q

$$\left(\frac{\alpha+2}{2}, \frac{\beta+1}{2}, \frac{\gamma+6}{2} \right),$$

which lies in line PQ .

$$\Rightarrow \frac{\frac{\alpha+2}{2} - 2}{2} = \frac{\frac{\beta+1}{2} - 1}{1} = \frac{\frac{\gamma+6}{2} - 6}{-2}$$

$$= \frac{1\left(\frac{\alpha+2}{2} - 2\right) + 1\left(\frac{\beta+1}{2} - 1\right) - 2\left(\frac{\gamma+6}{2} - 6\right)}{1 \cdot 1 + 1 \cdot 1 + (-2)(-2)} = 2$$

$$\left[\because \left(\frac{\alpha+2}{2}\right) - 1 - 1\left(\frac{\beta+1}{2}\right) - 2\left(\frac{\gamma+6}{2}\right) = 3 \right]$$

$$\Rightarrow \alpha = 6, \beta = 5, \gamma = -2$$

$$\Rightarrow Q(6, 5, -2)$$

26

Miscellaneous

Objective Questions I (Only one correct option)

- A survey shows that 63% of the people in a city read newspaper A whereas 76% read newspaper B . If $x\%$ of the people read both the newspapers, then a possible value of x can be (2020 Main, 4 Sep I)
(a) 55 (b) 29 (c) 65 (d) 37
- Let S be the set of all real roots of the equation, $3^x(3^x - 1) + 2 = |3^x - 1| + |3^x - 2|$. Then S (2020 Main, 8 Jan II)
(a) is a singleton.
(b) is an empty set.
(c) contains at least four elements.
(d) contains exactly two elements.
- Which one of the following is a tautology? (2020 Main, 8 Jan I)
(a) $(P \wedge (P \rightarrow Q)) \rightarrow Q$ (b) $P \wedge (P \vee Q)$
(c) $P \vee (P \wedge Q)$ (d) $Q \rightarrow (P \wedge (P \rightarrow Q))$
- The proposition $p \rightarrow \sim(p \wedge \sim q)$ is equivalent to (2020 Main, 3 Sep I)
(a) q (b) $(\sim p) \vee q$
(c) $(\sim p) \wedge q$ (d) $(\sim p) \vee (\sim q)$
- The boolean expression $\sim(p \Rightarrow (\sim q))$ is equivalent to (2019 Main, 12 April II)
(a) $p \wedge q$ (b) $q \Rightarrow \sim p$ (c) $p \vee q$ (d) $(\sim p) \Rightarrow q$
- If the data x_1, x_2, \dots, x_{10} is such that the mean of first four of these is 11, the mean of the remaining six is 16 and the sum of squares of all of these is 2000, then the standard deviation of this data is (2019 Main, 12 April I)
(a) $2\sqrt{2}$ (b) 2 (c) 4 (d) $\sqrt{2}$
- If the truth value of the statement $p \rightarrow (\sim q \vee r)$ is false (F), then the truth values of the statements p, q and r are respectively (2019 Main, 12 April II)
(a) T, T and F (b) T, F and F
(c) T, F and T (d) F, T and T
- The negation of the boolean expression $\sim s \vee (\sim r \wedge s)$ is equivalent to (2019 Main, 10 April II)
(a) $s \wedge r$ (b) $\sim s \wedge \sim r$ (c) $s \vee r$ (d) r
- If both the mean and the standard deviation of 50 observations x_1, x_2, \dots, x_{50} are equal to 16, then the mean of $(x_1 - 4)^2, (x_2 - 4)^2, \dots, (x_{50} - 4)^2$ is (2019 Main, 10 April II)
(a) 480 (b) 400 (c) 380 (d) 525

- Which one of the following Boolean expressions is a tautology? (2019 Main, 10 April I)

- (a) $(p \vee q) \vee (p \vee \sim q)$ (b) $(p \wedge q) \vee (p \wedge \sim q)$
(c) $(p \vee q) \wedge (p \vee \sim q)$ (d) $(p \vee q) \wedge (\sim p \vee \sim q)$

- If for some $x \in R$, the frequency distribution of the marks obtained by 20 students in a test is

Marks	2	3	5	7
Frequency	$(x + 1)^2$	$2x - 5$	$x^2 - 3x$	x

Then, the mean of the marks is (2019 Main, 10 April I)

- (a) 3.0 (b) 2.8
(c) 2.5 (d) 3.2

- Two newspapers A and B are published in a city. It is known that 25% of the city population reads A and 20% reads B while 8% reads both A and B . Further, 30% of those who read A but not B look into advertisements and 40% of those who read B but not A also look into advertisements, while 50% of those who read both A and B look into advertisements. Then, the percentage of the population who look into advertisements is (2019 Main, 9 April II)

- (a) 13.5 (b) 13
(c) 12.8 (d) 13.9

- The mean and the median of the following ten numbers in increasing order 10, 22, 26, 29, 34, x , 42, 67, 70, y are 42 and 35 respectively, then $\frac{y}{x}$ is equal to (2019 Main, 9 April II)

- (a) $\frac{7}{3}$ (b) $\frac{7}{2}$ (c) $\frac{8}{3}$ (d) $\frac{9}{4}$

- If $p \Rightarrow (q \vee r)$ is false, then the truth values of p, q, r are respectively (2019 Main, 9 April II)

- (a) T, T, F (b) T, F, F
(c) F, F, F (d) F, T, T

- For any two statements p and q , the negation of the expression $p \vee (\sim p \wedge q)$ is (2019 Main, 9 April I)

- (a) $\sim p \wedge \sim q$ (b) $\sim p \vee \sim q$
(c) $p \wedge q$ (d) $p \leftrightarrow q$

- If the standard deviation of the numbers $-1, 0, 1, k$ is $\sqrt{5}$ where $k > 0$, then k is equal to (2019 Main, 9 April I)

- (a) $2\sqrt{\frac{10}{3}}$ (b) $2\sqrt{6}$ (c) $4\sqrt{\frac{5}{3}}$ (d) $\sqrt{6}$

17. A student scores the following marks in five tests 45, 54, 41, 57, 43. His score is not known for the sixth test. If the mean score is 48 in the six tests, then the standard deviation of the marks in six tests is
(2019 Main, 8 April II)
- (a) $\frac{10}{3}$ (b) $\frac{10}{\sqrt{3}}$ (c) $\frac{100}{\sqrt{3}}$ (d) $\frac{100}{3}$
18. Which one of the following statements is not a tautology?
(2019 Main, 8 April II)
- (a) $(p \wedge q) \rightarrow (\sim p) \vee q$ (b) $(p \wedge q) \rightarrow p$
(c) $p \rightarrow (p \vee q)$ (d) $(p \vee q) \rightarrow (p \vee (\sim q))$
19. The sum of all natural numbers 'n' such that $100 < n < 200$ and $\text{HCF}(91, n) > 1$ is
(2019 Main, 8 April I)
- (a) 3203 (b) 3303
(c) 3221 (d) 3121
20. The mean and variance of seven observations are 8 and 16, respectively. If 5 of the observations are 2, 4, 10, 12, 14, then the product of the remaining two observations is
(2019 Main, 8 April I)
- (a) 45 (b) 49 (c) 48 (d) 40
21. All possible numbers are formed using the digits 1, 1, 2, 2, 2, 2, 3, 4, 4 taken all at a time. The number of such numbers in which the odd digits occupy even places is
(2019 Main, 8 April I)
- (a) 180 (b) 175
(c) 160 (d) 162
22. The contrapositive of the statement "If you are born in India, then you are a citizen of India", is
(2019 Main, 8 April I)
- (a) If you are not a citizen of India, then you are not born in India.
(b) If you are a citizen of India, then you are born in India.
(c) If you are born in India, then you are not a citizen of India.
(d) If you are not born in India, then you are not a citizen of India.
23. The mean and the variance of five observations are 4 and 5.20, respectively. If three of the observations are 3, 4 and 4, then the absolute value of the difference of the other two observations, is
(2019 Main, 12 Jan II)
- (a) 1 (b) 7 (c) 5 (d) 3
24. In a class of 60 students, 40 opted for NCC, 30 opted for NSS and 20 opted for both NCC and NSS. If one of these students is selected at random, then the probability that the student selected has opted neither for NCC nor for NSS is
(2019 Main, 12 Jan II)
- (a) $\frac{1}{6}$ (b) $\frac{1}{3}$ (c) $\frac{2}{3}$ (d) $\frac{5}{6}$
25. Let Z be the set of integers. If $A = \{x \in Z : 2^{(x+2)}(x^2 - 5x + 6) = 1\}$ and $B = \{x \in Z : -3 < 2x - 1 < 9\}$, then the number of subsets of the set $A \times B$, is
(2019 Main, 12 Jan II)
- (a) 2^{12} (b) 2^{18} (c) 2^{15} (d) 2^{10}
26. The expression $\sim(\sim p \rightarrow q)$ is logically equivalent to
(2019 Main, 12 Jan II)
- (a) $p \wedge \sim q$ (b) $p \wedge q$
(c) $\sim p \wedge q$ (d) $\sim p \wedge \sim q$
27. The Boolean expression $((p \wedge q) \vee (p \vee \sim q)) \wedge (\sim p \wedge \sim q)$ is equivalent to
(2019 Main, 12 Jan I)
- (a) $p \wedge q$ (b) $p \vee (\sim q)$
(c) $p \wedge (\sim q)$ (d) $(\sim p) \wedge (\sim q)$
28. If the sum of the deviations of 50 observations from 30 is 50, then the mean of these observations is
(2019 Main, 12 Jan I)
- (a) 50 (b) 30 (c) 51 (d) 31
29. Let $S = \{1, 2, 3, \dots, 100\}$. The number of non-empty subsets A of S such that the product of elements in A is even, is
(2019 Main, 12 Jan I)
- (a) $2^{50}(2^{50} - 1)$ (b) $2^{50} - 1$
(c) $2^{50} + 1$ (d) $2^{100} - 1$
30. A bag contains 30 white balls and 10 red balls. 16 balls are drawn one by one randomly from the bag with replacement. If X be the number of white balls drawn, then $\left(\frac{\text{mean of } X}{\text{standard deviation of } X}\right)$ is equal to
(2019 Main, 11 Jan II)
- (a) $\frac{4\sqrt{3}}{3}$ (b) 4
(c) $3\sqrt{2}$ (d) $4\sqrt{3}$
31. Contrapositive of the statement "If two numbers are not equal, then their squares are not equal" is
(2019 Main, 11 Jan II)
- (a) If the squares of two numbers are not equal, then the numbers are not equal.
(b) If the squares of two numbers are equal, then the numbers are equal.
(c) If the squares of two numbers are not equal, then the numbers are equal.
(d) If the squares of two numbers are equal, then the numbers are not equal.
32. If q is false and $p \wedge q \leftrightarrow r$ is true, then which one of the following statements is a tautology?
(2019 Main, 11 Jan I)
- (a) $p \vee r$ (b) $(p \wedge r) \rightarrow (p \vee r)$
(c) $(p \vee r) \rightarrow (p \wedge r)$ (d) $p \wedge r$
33. The outcome of each of 30 items was observed; 10 items gave an outcome $\frac{1}{2} - d$ each, 10 items gave outcome $\frac{1}{2}$ each and the remaining 10 items gave outcome $\frac{1}{2} + d$ each. If the variance of this outcome data is $\frac{4}{3}$, then $|d|$ equals
(2019 Main, 11 Jan I)
- (a) $\frac{2}{3}$ (b) $\frac{\sqrt{5}}{2}$
(c) $\sqrt{2}$ (d) 2

608 Miscellaneous

- 34.** Consider the following three statements :
 P : 5 is a prime number.
 Q : 7 is a factor of 192.
 R : LCM of 5 and 7 is 35.
 Then, the truth value of which one of the following statements is true? (2019 Main, 10 Jan II)
 (a) $(P \wedge Q) \vee (\sim R)$
 (b) $P \vee (\sim Q \wedge R)$
 (c) $(\sim P) \vee (Q \wedge R)$
 (d) $(\sim P) \wedge (\sim Q \wedge R)$
- 35.** The mean of five observations is 5 and their variance is 9.20. If three of the given five observations are 1, 3 and 8, then a ratio of other two observations is (2019 Main, 10 Jan I)
 (a) 4 : 9 (b) 6 : 7
 (c) 10 : 3 (d) 5 : 8
- 36.** In a class of 140 students numbered 1 to 140, all even numbered students opted Mathematics course, those whose number is divisible by 3 opted Physics course and those whose number is divisible by 5 opted Chemistry course. Then, the number of students who did not opt for any of the three courses is (2019 Main, 10 Jan I)
 (a) 42 (b) 102
 (c) 38 (d) 1
- 37.** Consider the statement : " $P(n) : n^2 - n + 41$ is prime." Then, which one of the following is true? (2019 Main, 10 Jan I)
 (a) Both $P(3)$ and $P(5)$ are true.
 (b) $P(3)$ is false but $P(5)$ is true.
 (c) Both $P(3)$ and $P(5)$ are false.
 (d) $P(5)$ is false but $P(3)$ is true.
- 38.** The logical statement
 $[\sim(\sim p \vee q) \vee (p \wedge r)] \wedge (\sim q \wedge r)$
 is equivalent to (2019 Main, 9 Jan II)
 (a) $\sim p \vee r$ (b) $(p \wedge \sim q) \vee r$
 (c) $(p \wedge r) \wedge \sim q$ (d) $(\sim p \wedge \sim q) \wedge r$
- 39.** In a group of data, there are n observations, x, x_2, \dots, x_n . If $\sum_{i=1}^n (x_i + 1)^2 = 9n$ and $\sum_{i=1}^n (x_i - 1)^2 = 5n$, the standard deviation of the data is (2019 Main, 9 Jan II)
 (a) 2 (b) $\sqrt{7}$
 (c) 5 (d) $\sqrt{5}$
- 40.** If the Boolean expression
 $(p \oplus q) \wedge (\sim p \cdot q)$ is equivalent to $p \wedge q$, where
 $\oplus, \cdot \in \{\wedge, \vee\}$, then the ordered pair (\oplus, \cdot) is (2019 Main, 9 Jan I)
 (a) (\wedge, \vee) (b) (\wedge, \wedge)
 (c) (\vee, \wedge) (d) (\vee, \vee)
- 41.** 5 students of a class have an average height 150 cm and variance 18 cm^2 . A new student, whose height is 156 cm, joined them. The variance (in cm^2) of the height of these six students is (2019 Main, 9 Jan I)
 (a) 16 (b) 22 (c) 20 (d) 18
- 42.** Two sets A and B are as under
 $A = \{(a, b) \in \mathbf{R} \times \mathbf{R} : |a - 5| < 1 \text{ and } |b - 5| < 1\}$;
 $B = \{(a, b) \in \mathbf{R} \times \mathbf{R} : 4(a - 6)^2 + 9(b - 5)^2 \leq 36\}$. Then, (2018 Main)
 (a) $B \subset A$ (b) $A \subset B$
 (c) $A \cap B = \phi$ (an empty set) (d) neither $A \subset B$ nor $B \subset A$
- 43.** If $\sum_{i=1}^9 (x_i - 5) = 9$ and $\sum_{i=1}^9 (x_i - 5)^2 = 45$, then the standard deviation of the 9 items x_1, x_2, \dots, x_9 is (2018 Main)
 (a) 9 (b) 4 (c) 2 (d) 3
- 44.** The boolean expression $\sim(p \vee q) \vee (\sim p \wedge q)$ is equivalent to (2018 Main)
 (a) $\sim p$ (b) p
 (c) q (d) $\sim q$
- 45.** If S is the set of distinct values of b for which the following system of linear equations

$$x + y + z = 1,$$

$$x + ay + z = 1$$
 and $ax + by + z = 0$
 has no solution, then S is (2017 Main)
 (a) an infinite set
 (b) a finite set containing two or more elements
 (c) singleton set
 (d) an empty set
- 46.** The statement $(p \rightarrow q) \rightarrow [(\sim p \rightarrow q) \rightarrow q]$ is (2017 Main)
 (a) a tautology (b) equivalent to $\sim p \rightarrow q$
 (c) equivalent to $p \rightarrow \sim q$ (d) a fallacy
- 47.** If $f(x) + 2f\left(\frac{1}{x}\right) = 3x, x \neq 0$ and
 $S = \{x \in \mathbf{R} : f(x) = f(-x)\}$; then S (2016 Main)
 (a) is an empty set
 (b) contains exactly one element
 (c) contains exactly two elements
 (d) contains more than two elements
- 48.** If the standard deviation of the numbers 2, 3, a and 11 is 3.5, then which of the following is true? (2016 Main)
 (a) $3a^2 - 26a + 55 = 0$ (b) $3a^2 - 32a + 84 = 0$
 (c) $3a^2 - 34a + 91 = 0$ (d) $3a^2 - 23a + 44 = 0$
- 49.** The Boolean expression $(p \wedge \sim q) \vee q \vee (\sim p \wedge q)$ is equivalent to (2016 Main)
 (a) $\sim p \wedge q$ (b) $p \wedge q$
 (c) $p \vee q$ (d) $p \vee \sim q$
- 50.** The negation of $\sim s \vee (\sim r \wedge s)$ is equivalent to (2015 Main)
 (a) $s \wedge \sim r$ (b) $s \wedge (r \wedge \sim s)$
 (c) $s \wedge (r \vee \sim s)$ (d) $s \wedge r$
- 51.** The mean of the data set comprising of 16 observations is 16. If one of the observations valued 16 is deleted and three new observations valued 3, 4 and 5 added to the data, then the mean of the resultant data is (2015 Main)
 (a) 16.8 (b) 16.0 (c) 15.8 (d) 14.0

52. If A and B are two sets containing four and two elements, respectively. Then, the number of subsets of the set $A \times B$ each having atleast three elements are (2015 Main)
 (a) 219 (b) 256 (c) 275 (d) 510
53. If the angles of elevation of the top of a tower from three collinear points A, B and C on a line leading to the foot of the tower are $30^\circ, 45^\circ$ and 60° respectively, then the ratio $AB : BC$ is (2015 Main)
 (a) $\sqrt{3}:1$ (b) $\sqrt{3}:\sqrt{2}$
 (c) $1:\sqrt{3}$ (d) $2:3$
54. The statement $\sim(p \leftrightarrow \sim q)$ is (2014 Main)
 (a) equivalent to $p \leftrightarrow q$ (b) equivalent to $\sim p \leftrightarrow q$
 (c) a tautology (d) a fallacy
55. A bird is sitting on the top of a vertical pole 20 m high and its elevation from a point O on the ground is 45° . It flies off horizontally straight away from the point O . After 1 s, the elevation of the bird from O is reduced to 30° . Then, the speed (in m/s) of the bird is (2014 Main)
 (a) $40(\sqrt{2} - 1)$ (b) $40(\sqrt{3} - \sqrt{2})$
 (c) $20\sqrt{2}$ (d) $20(\sqrt{3} - 1)$
56. If $X = \{4^n - 3n - 1 : n \in N\}$ and $Y = \{9(n - 1) : n \in N\}$, where N is the set of natural numbers, then $X \cup Y$ is equal to (2014 Main)
 (a) N (b) $Y - X$ (c) X (d) Y
57. The variance of first 50 even natural numbers is (2014 Main)
 (a) $\frac{833}{4}$ (b) 833 (c) 437 (d) $\frac{437}{4}$
58. All the students of a class performed poorly in Mathematics. The teacher decided to give grace marks of 10 to each of the students. Which of the following statistical measures will not change even after the grace marks were given? (2013 Main)
 (a) Mean (b) Median
 (c) Mode (d) Variance
59. If A and B two sets containing 2 elements and 4 elements, respectively. Then, the number of subsets of $A \times B$ having 3 or more elements, is (2013 Main)
 (a) 256 (b) 220 (c) 219 (d) 211
60. The number $\log_2 7$ is
 (a) an integer (b) a rational number
 (c) an irrational number (d) a prime number
61. If $\log_{0.3}(x - 1) < \log_{0.09}(x - 1)$, then x lies in the interval (1985, 2M)
 (a) $(2, \infty)$ (b) $(1, 2)$
 (c) $(-2, -1)$ (d) None of these
62. Consider any set of 201 observations $x_1, x_2, \dots, x_{200}, x_{201}$. It is given that $x_1 < x_2 < \dots < x_{200} < x_{201}$. Then, the mean deviation of this set of observations about a point k is minimum, when k equals (1981, 2M)
 (a) $(x_1 + x_2 + \dots + x_{200} + x_{201}) / 201$
 (b) x_1
 (c) x_{101}
 (d) x_{201}

63. The least value of the expression $2 \log_{10} x - \log_x(0.01)$, for $x > 1$, is (1980, 2M)
 (a) 10 (b) 2
 (c) -0.01 (d) None of these

Objective Questions II

(One or more than one correct option)

64. Let $f : R \rightarrow (0, 1)$ be a continuous function. Then, which of the following function(s) has (have) the value zero at some point in the interval $(0, 1)$? (2017 Adv.)
 (a) $e^x - \int_0^x f(t) \sin t \, dt$ (b) $f(x) + \int_0^{\frac{\pi}{2}} f(t) \sin t \, dt$
 (c) $x - \int_0^{\frac{\pi}{2}} f(t) \cos t \, dt$ (d) $x^9 - f(x)$
65. If $3^x = 4^{x-1}$, then x is equal to (2013 Adv.)
 (a) $\frac{2 \log_3 2}{2 \log_3 2 - 1}$ (b) $\frac{2}{2 - \log_2 3}$
 (c) $\frac{1}{1 - \log_4 3}$ (d) $\frac{2 \log_2 3}{2 \log_2 3 - 1}$

Integer & Numerical Answer Type Questions

66. Let $|X|$ denote the number of elements in a set X . Let $S = \{1, 2, 3, 4, 5, 6\}$ be a sample space, where each element is equally likely to occur. If A and B are independent events associated with S , then the number of ordered pairs (A, B) such that $1 \leq |B| < |A|$, equals (2019 Adv.)
67. The value of $((\log_2 9)^2)^{\frac{1}{\log_2(\log_2 9)}} \times (\sqrt{7})^{\frac{1}{\log_4 7}}$ is (2018 Adv.)
68. Let X be the set consisting of the first 2018 terms of the arithmetic progression 1, 6, 11, ..., and Y be the set consisting of the first 2018 terms of the arithmetic progression 9, 16, 23, Then, the number of elements in the set $X \cup Y$ is (2018 Adv.)
69. Let X be a set with exactly 5 elements and Y be a set with exactly 7 elements. If α is the number of one-one functions from X to Y and β is the number of onto functions from Y to X , then the value of $\frac{1}{5!}(\beta - \alpha)$ is (2018 Adv.)

Assertion /Reason

70. Consider
Statement I $(p \wedge \sim q) \wedge (\sim p \wedge q)$ is a fallacy.
Statement II $(p \rightarrow q) \leftrightarrow (\sim q \rightarrow \sim p)$ is a tautology. (2013 Main)
 (a) Statement I is true, Statement II is true; Statement II is a correct explanation for Statement I
 (b) Statement I is true, Statement II is true; Statement II is not a correct explanation for Statement I
 (c) Statement I is true; Statement II is false
 (d) Statement I is false; Statement II is true

610 Miscellaneous

Match the Columns

71. Let the circles $C_1 : x^2 + y^2 = 9$ and $C_2 : (x - 3)^2 + (y - 4)^2 = 16$, intersect at the points X and Y . Suppose that another circle $C_3 : (x - h)^2 + (y - k)^2 = r^2$ satisfies the following conditions :

- Centre of C_3 is collinear with the centres of C_1 and C_2 .
- C_1 and C_2 both lie inside C_3 and
- C_3 touches C_1 at M and C_2 at N .

Let the line through X and Y intersect C_3 at Z and W , and let a common tangent of C_1 and C_3 be a tangent to the parabola $x^2 = 8\alpha y$.

There are some expression given in the List-I whose values are given in List-II below.

List-I	List-II
(I) $2h + k$	(P) 6
(II) $\frac{\text{Length of } ZW}{\text{Length of } XY}$	(Q) $\sqrt{6}$
(III) $\frac{\text{Area of triangle } MZN}{\text{Area of triangle } ZMW}$	(R) $\frac{5}{4}$
(IV) α	(S) $\frac{21}{5}$
	(T) $2\sqrt{6}$
	(U) $\frac{10}{3}$

Which of the following is the only INCORRECT combination? (2019 Adv.)

- (III), (R)
- (IV), (S)
- (I), (P)
- (IV), (U)

72. Let the circles $C_1 : x^2 + y^2 = 9$ and $C_2 : (x - 3)^2 + (y - 4)^2 = 16$, intersect at the points X and Y . Suppose that another circle $C_3 : (x - h)^2 + (y - k)^2 = r^2$ satisfies the following conditions :

- centre of C_3 is collinear with the centers of C_1 and C_2 .
- C_1 and C_2 both lie inside C_3 , and
- C_3 touches C_1 at M and C_2 at N .

Let the line through X and Y intersect C_3 at Z and W , and let a common tangent of C_1 and C_3 be a tangent to the parabola $x^2 = 8\alpha y$.

There are some expression given in the List-I whose values are given in List-II below.

List-I	List-II
(I) $2h + k$	(P) 6
(II) $\frac{\text{Length of } ZW}{\text{Length of } XY}$	(Q) $\sqrt{6}$
(III) $\frac{\text{Area of triangle } MZN}{\text{Area of triangle } ZMW}$	(R) $\frac{5}{4}$
(IV) α	(S) $\frac{21}{5}$
	(T) $2\sqrt{6}$
	(U) $\frac{10}{3}$

Which of the following is the only CORRECT combination? (2019 Adv.)

- (II), (T)
- (I), (S)
- (II), (Q)
- (I), (U)

Directions (Q.Nos. 73-75) by appropriately matching the information given in the three columns of the following table.

Columns 1, 2 and 3 contain conics, equations of tangents to the conics and points of contact, respectively.

Column-1	Column-2	Column-3
(I) $x^2 + y^2 = a^2$	(i) $my = m^2x + a$	(P) $\left(\frac{a}{m^2}, \frac{2a}{m}\right)$
(II) $x^2 + a^2y^2 = a^2$	(ii) $y = mx + a\sqrt{m^2 + 1}$	(Q) $\left(\frac{-ma}{\sqrt{m^2 + 1}}, \frac{a}{\sqrt{m^2 + 1}}\right)$
(III) $y^2 = 4ax$	(iii) $y = mx + \sqrt{a^2m^2 - 1}$	(R) $\left(\frac{-a^2m}{\sqrt{a^2m^2 + 1}}, \frac{1}{\sqrt{a^2m^2 + 1}}\right)$
(IV) $x^2 - a^2y^2 = a^2$	(iv) $y = mx + \sqrt{a^2m^2 + 1}$	(S) $\left(\frac{-a^2m}{\sqrt{a^2m^2 - 1}}, \frac{-1}{\sqrt{a^2m^2 - 1}}\right)$

73. For $a = \sqrt{2}$, if a tangent is drawn to a suitable conic (Column 1) at the point of contact $(-1, 1)$, then which of the following options is the only CORRECT combination for obtaining its equation? (2017 Adv.)

- (I) (ii) (Q)
- (I) (i) (P)
- (III) (i) (P)
- (II) (ii) (Q)

74. The tangent to a suitable conic (Column 1) at $\left(\sqrt{3}, \frac{1}{2}\right)$ is found to be $\sqrt{3}x + 2y = 4$, then which of the following options is the only CORRECT combination? (2017 Adv.)

- (IV) (iv) (S)
- (II) (iv) (R)
- (IV) (iii) (S)
- (II) (iii) (R)

75. If a tangent to a suitable conic (Column 1) is found to be $y = x + 8$ and its point of contact is $(8, 16)$, then which of the following options is the only CORRECT combination? (2017 Adv.)

- (III) (i) (P)
- (I) (ii) (Q)
- (II) (iv) (R)
- (III) (ii) (Q)

76.	Column I	Column II
A.	In R^2 , if the magnitude of the projection vector of the vector $\alpha \hat{i} + \beta \hat{j}$ on $\sqrt{3}\hat{i} + \hat{j}$ is $\sqrt{3}$ and if $\alpha = 2 + \sqrt{3}\beta$, then possible value(s) of $ \alpha $ is/are	P. 1
B.	Let a and b be real numbers such that the function $f(x) = \begin{cases} -3ax^2 - 2, & x < 1 \\ bx + a^2, & x \geq 1 \end{cases}$ is differentiable for all $x \in R$. Then, possible value(s) of a is/are	Q. 2
C.	Let $\omega (\neq 1)$ be a complex cube root of unity. If $(3 - 3\omega + 2\omega^2)^{4n+3} + (2 + 3\omega - 3\omega^2)^{4n+3} + (-3 + 2\omega + 3\omega^2)^{4n+3} = 0$, then the possible value(s) of n is/are	R. 3
D.	Let the harmonic mean of two positive real numbers a and b be 4. If q is a positive real number such that $a, 5, q, b$ is in arithmetic progression, then the value(s) of $ q - 2a $ is/are	S. 4
		T. 5

(2015 Adv.)

77.	Column I	Column II
A.	In ΔXYZ , let a, b and c be the lengths of the sides opposite to the angles X, Y and Z , respectively. If $2(a^2 - b^2) = c^2$ and $\lambda = \frac{\sin(X - Y)}{\sin Z}$, then possible value(s) of n for which $\cos(n\pi\lambda) = 0$, is/are	p. 1
B.	In ΔXYZ , let a, b and c be the lengths of the sides opposite to the angles X, Y and Z , respectively. If $1 + \cos 2X - 2 \cos 2Y = 2 \sin X \sin Y$, then possible value(s) of $\frac{a}{b}$ is/are	q. 2
C.	In R^2 , let $\sqrt{3}\hat{i} + \hat{j}, \hat{i} + \sqrt{3}\hat{j}$ and $\beta\hat{i} + (1 - \beta)\hat{j}$ be the position vectors of X, Y and Z with respect to the origin O , respectively. If the distance of Z from the bisector of the acute angle of \mathbf{OX} with \mathbf{OY} is $\frac{3}{\sqrt{2}}$, then possible value(s) of $ \beta $ is/are	r. 3
D.	Suppose that $F(\alpha)$ denotes the area of the region bounded by $x = 0, x = 2, y^2 = 4x$ and $y = \alpha x - 1 + \alpha x - 2 + \alpha x$, where $\alpha \in \{0, 1\}$. Then, the value(s) of $F(\alpha) + \frac{8}{3}\sqrt{2}$, when $\alpha = 0$ and $\alpha = 1$, is/are	s. 5
		t. 6

(2015 Adv.)

78. Match List I with List II and select the correct answer using the codes given below the lists.

(2015)

	List I	List II
P.	Let $y(x) = \cos(3\cos^{-1}x), x \in [-1, 1], x \neq \pm \frac{\sqrt{3}}{2}$. Then, $\frac{1}{y(x)} \left\{ (x^2 - 1) \frac{d^2y(x)}{dx^2} + \frac{xdy(x)}{dx} \right\}$ equals	(i) 1
Q.	Let $A_1, A_2, \dots, A_n (n > 2)$ be the vertices of a regular polygon of n sides with its centre at the origin. Let a_k be the position vector of the point $A_k, k = 1, 2, \dots, n$. If $\left \sum_{k=1}^{n-1} (\mathbf{a}_k \cdot \mathbf{a}_{k+1}) \right = \left \sum_{k=1}^{n-1} (\mathbf{a}_k \cdot \mathbf{a}_{k+1}) \right $, then the minimum value of n is	(ii) 2
R.	If the normal from the point $P(h, 1)$ on the ellipse $\frac{x^2}{6} + \frac{y^2}{3} = 1$ is perpendicular to the line $x + y = 8$, then the value of h is	(iii) 8
S.	Number of positive solutions satisfying the equation $\tan^{-1}\left(\frac{1}{2x+1}\right) + \tan^{-1}\left(\frac{1}{4x+1}\right) = \tan^{-1}(2/x^2)$ is	(iv) 9

612 Miscellaneous

Codes

	P	Q	R	S		P	Q	R	S
(a)	(iv)	(iii)	(ii)	(i)	(b)	(ii)	(iv)	(iii)	(i)
(c)	(iv)	(iii)	(i)	(ii)	(d)	(ii)	(iv)	(i)	(iii)

79. Match the statements given in Column I with the intervals/union of intervals given in Column II. (2011)

	Column I		Column II
A.	The set $\left\{ \operatorname{Re} \left(\frac{2iz}{1-z^2} \right) : z \text{ is a complex number, } z = 1, z \neq \pm 1 \right\}$	p.	$(-\infty, -1) \cup (1, \infty)$
B.	The domain of the function $f(x) = \sin^{-1} \left(\frac{8(3)^x - 2}{1 - 3^{2(x-1)}} \right)$ is	q.	$(-\infty, 0) \cup (0, \infty)$
C.	If $f(\theta) = \begin{vmatrix} 1 & \tan\theta & 1 \\ -\tan\theta & 1 & \tan\theta \\ -1 & -\tan\theta & 1 \end{vmatrix}$, then the set $\{f(\theta) : 0 \leq \theta < \frac{\pi}{2}\}$ is	r.	$[2, \infty)$
D.	If $f(x) = x^{3/2}(3x - 10)$, $x \geq 0$, then $f(x)$ is increasing in	s.	$(-\infty, -1] \cup [1, \infty)$
		t.	$(-\infty, 0] \cup [2, \infty)$

80. Match the statements given in Column I with the values given in Column II. (2011)

	Column I		Column II
A.	If $\vec{a} = \hat{j} + \sqrt{3}\hat{k}$, $\vec{b} = -\hat{j} + \sqrt{3}\hat{k}$ and $\vec{c} = 2\sqrt{3}\hat{k}$ form a triangle, then the internal angle of the triangle between \vec{a} and \vec{b} is	p.	$\frac{\pi}{6}$
B.	If $\int_a^b [f(x) - 3x] dx = a^2 - b^2$, then the value of $f\left(\frac{\pi}{6}\right)$ is	q.	$\frac{2\pi}{3}$
C.	The value of $\frac{\pi^2}{\log 3} \int_{7/6}^{5/6} \sec(\pi x) dx$ is	r.	$\frac{\pi}{3}$
D.	The maximum value of $\left \arg \left(\frac{1}{1-z} \right) \right $ for $ z = 1, z \neq 1$ is given by	s.	π
		t.	$\frac{\pi}{2}$

81. Match the statements of Column I with values of Column II. (2010)

	Column I		Column II
A.	A line from the origin meets the lines $\frac{x-2}{1} = \frac{y-1}{-2} = \frac{z+1}{1}$ and $\frac{x-8/3}{2} = \frac{y+3}{-1} = \frac{z-1}{1}$ at P and Q respectively. If length $PQ = d$, then d^2 is	p.	-4
B.	The value of x satisfying $\tan^{-1}(x+3) - \tan^{-1}(x-3) = \sin^{-1}(3/5)$ is	q.	0
C.	Non-zero vectors \vec{a} , \vec{b} and \vec{c} satisfy $\vec{a} \cdot \vec{b} = 0$, $(\vec{b} - \vec{a}) \cdot (\vec{b} + \vec{c}) = 0$ and $2 \vec{b} + \vec{c} = \vec{b} - \vec{a} $. If $\vec{a} = \mu \vec{b} + 4\vec{c}$, then the possible value of μ is	r.	4
D.	Let f be the function on $[-\pi, \pi]$ given by $f(0) = 9$ and $f(x) = \sin\left(\frac{9x}{2}\right) / \sin\left(\frac{x}{2}\right)$ for $x \neq 0$. The value of $\frac{2}{\pi} \int_{-\pi}^{\pi} f(x) dx$ is	s.	5
		t.	6

82. Match the statements/expressions given in Column I with the values given in Column II. (2009)

Column I		Column II	
A.	Root(s) of the equation $2\sin^2\theta + \sin^22\theta = 2$	p.	$\pi/6$
B.	Points of discontinuity of the function $f(x) = \left[\frac{6x}{\pi} \right] \cos \left[\frac{3x}{\pi} \right]$, where $[y]$ denotes the largest integer less than or equal to y	q.	$\pi/4$
C.	Volume of the parallelepiped with its edges represented by the vectors $\hat{i} + \hat{j}$, $\hat{i} + 2\hat{j}$ and $\hat{i} + \hat{j} + \pi\hat{k}$	r.	$\pi/3$
D.	Angle between vectors \vec{a} and \vec{b} , where \vec{a} , \vec{b} and \vec{c} are unit vectors satisfying $\vec{a} + \vec{b} + \sqrt{3}\vec{c} = \vec{0}$	s.	$\pi/2$
		t.	π

83. Match the statements/expressions given in Column I with the values given in Column II.

Column I		Column II	
(A)	The number of solutions of the equation $x e^{\sin x} - \cos x = 0$ in the interval $\left(0, \frac{\pi}{2}\right)$ is	(p)	1
(B)	Value(s) of k for which the planes $kx + 4y + z = 0$, $4x + ky + 2z = 0$ and $2x + 2y + z = 0$ intersect in a straight line is	(q)	2
(C)	Value(s) of k for which $ x - 1 + x - 2 + x + 1 + x + 2 = 4k$ has integer solution(s) is	(r)	3
(D)	If $y' = y + 1$ and $y(0) = 1$, then value(s) of $y(\ln 2)$ is	(s)	4
		(t)	5

(2009)

84. Match the conics in Column I with the statements/expressions in Column II.

Column I		Column II	
A.	Circle	p.	The locus of the point (h, k) for which the line $hx + ky = 1$ touches the circle $x^2 + y^2 = 4$
B.	Parabola	q.	Points z in the complex plane satisfying $ z + 2 - z - 2 = \pm 3$
C.	Ellipse	r.	Points of the conic have parametric representation $x = \sqrt{3} \left(\frac{1-t^2}{1+t^2} \right)$, $y = \frac{2t}{1+t^2}$
D.	Hyperbola	s.	The eccentricity of the conic lies in the interval $1 \leq e < \infty$
		t.	Points in the complex plane satisfying $\operatorname{Re}(z + 1)^2 = z ^2 + 1$

(2009)

85. Match the statements/expressions in Column I with the open intervals in Column II.

Column I		Column II	
A.	Interval contained in the domain of definition of non-zero solutions of the differential equation $(x - 3)^2 y' + y = 0$	p.	$\left(-\frac{\pi}{2}, \frac{\pi}{2}\right)$
B.	Interval containing the value of the integral $\int_1^5 (x - 1)(x - 2)(x - 3)(x - 4)(x - 5) dx$	q.	$\left(0, \frac{\pi}{2}\right)$
C.	Interval in which atleast one of the points of local maximum of $\cos^2 x + \sin x$ lies	r.	$\left(\frac{\pi}{8}, \frac{5\pi}{4}\right)$
D.	Interval in which $\tan^{-1}(\sin x + \cos x)$ is increasing	s.	$\left(0, \frac{\pi}{8}\right)$
		t.	$(-\pi, \pi)$

(2009)

86. Match the statements/expressions given in Column I with the values given in Column II.

Column I		Column II	
A.	The minimum value of $\frac{x^2 + 2x + 4}{x + 2}$ is	p.	0
B.	Let A and B be 3×3 matrices of real numbers, where A is symmetric, B is skew-symmetric and $(A + B)(A - B) = (A - B)(A + B)$. If $(AB)^t = (-1)^k AB$, where $(AB)^t$ is the transpose of the matrix AB , then the possible values of k are	q.	1

614 Miscellaneous

	Column I	Column II
C.	Let $a = \log_3 \log_3 2$. An integer k satisfying $1 < 2^{(-k + 3^{-a})} < 2$, must be less than	r. 2
D.	If $\sin \theta = \cos \phi$, then the possible values of $\frac{1}{\pi} \left(\theta \pm \phi - \frac{\pi}{2} \right)$ are	s. 3

(2008 6M)

87. Match the statements/expressions given in Column I with the values given in Column II.

	Column I	Column II
A.	$\sum_{i=1}^{\infty} \tan^{-1} \left(\frac{1}{2i^2} \right) = t$, then $\tan t$ is	p. $\frac{2}{3}$
B.	Sides a, b, c of a ΔABC are in AP and $\cos \theta_1 = \frac{a}{b+c}, \cos \theta_2 = \frac{b}{a+c}, \cos \theta_3 = \frac{c}{a+b}$, then $\tan^2 \left(\frac{\theta_1}{2} \right) + \tan^2 \left(\frac{\theta_3}{2} \right)$ is	q. 1
C.	A line is perpendicular to $x + 2y + 2z = 0$ and passes through $(0, 1, 0)$. The perpendicular distance of this line from the origin is	r. $\frac{\sqrt{5}}{3}$

(2006 6M)

88. Match the statements/expressions given in Column I with the values given in Column II.

	Column I	Column II
A.	Two rays in I quadrant $x + y = a $ and $ax - y = 1$ intersect each other in the interval $a \in (a_0, \infty)$, then value of $\left(\frac{2a_0}{3} \right)$ is	p. 2
B.	Point (α, β, γ) lies on the plane $x + y + z = 2$. If $\vec{a} = \alpha \hat{i} + \beta \hat{j} + \gamma \hat{k}$ and $\hat{k} \times (\hat{k} \times \hat{a}) = \vec{0}$, then γ is	q. $\frac{2}{3}$
C.	$\left \int_0^1 (1 - y^2) dy \right + \left \int_1^0 (y^2 - 1) dy \right $	r. $\left \int_0^1 \sqrt{1-x} dx \right + \left \int_{-1}^0 \sqrt{1+x} dx \right $
D.	If $\sin A \sin B \sin C + \cos A \cos B = 1$, then the value of $\sin C$ is	s. 1

(2006, 6M)

Fill in the Blanks

89. If $x > 0, y < 0, x + y + \frac{x}{y} = \frac{1}{2}$ and $(x + y) \frac{x}{y} = -\frac{1}{2}$, then $x = \dots\dots\dots$ and $y = \dots\dots\dots$. (1990, 2M)

90. The solution of the equation $\log_7 \log_5 (\sqrt{x+5} + \sqrt{x}) = 0$ is

Analytical & Descriptive Questions

91. The marks obtained by 40 students are grouped in a frequency table in class intervals of 10 marks each. The mean and the variance obtained from this distribution are found to be 40 and 49, respectively. It was later discovered that two observations belonging to the class interval (21 - 30) were included in the class interval (31 - 40) by mistake. Find the mean and the variance after correcting the error. (1982, 3M)

92. The mean square deviations of a set of observations x_1, x_2, \dots, x_n about a point c is defined to be $\frac{1}{n} \sum_{i=1}^n (x_i - c)^2$.

The mean square deviations about -1 and $+1$ of a set of observations are 7 and 3, respectively. Find the standard deviation of this set of observations.

(1981, 2M)

Integer & Numerical Answer Type Questions

93. The total number of distincts $x \in [0, 1]$ for which $\int_0^x \frac{t^2}{1+t^4} dt = 2x - 1$ is (2016 Adv.)

94. Let $F(x) = \int_x^{x^2 + \frac{\pi}{6}} 2 \cos^2 t dt$ for all $x \in R$ and $f: \left[0, \frac{1}{2} \right] \rightarrow [0, \infty)$ be a continuous function. For $a \in \left[0, \frac{1}{2} \right]$, if $F'(a) + 2$ is the area of the region bounded by $x = 0, y = 0, y = f(x)$ and $x = a$, then $f(0)$ is (2015 Adv.)

95. The value of $6 + \log_{3/2} \left(\frac{1}{3\sqrt{2}} \sqrt{4 - \frac{1}{3\sqrt{2}}} \sqrt{4 - \frac{1}{3\sqrt{2}}} \sqrt{4 - \frac{1}{3\sqrt{2}}} \dots \right)$ is (2012)

Answers

- | | | | | |
|---------|----------|---------|------------|--|
| 1. (a) | 2. (a) | 3. (a) | 4. (b) | 76. $A \rightarrow p, q, s; B \rightarrow p, t; C \rightarrow p, q, r, t; D \rightarrow s$ |
| 5. (a) | 6. (b) | 7. (a) | 8. (a) | 77. $A \rightarrow p, r, s; B \rightarrow p; C \rightarrow p, q; D \rightarrow s, t$ |
| 9. (b) | 10. (a) | 11. (b) | 12. (d) | 78. (a) |
| 13. (a) | 14. (b) | 15. (a) | 16. (b) | 79. $A \rightarrow s, B \rightarrow t, C \rightarrow r, D \rightarrow r$ |
| 17. (b) | 18. (d) | 19. (d) | 20. (c) | 80. $A \rightarrow q; B \rightarrow p; C \rightarrow s; D \rightarrow s$ |
| 21. (a) | 22. (a) | 23. (b) | 24. (a) | 81. $A \rightarrow t, B \rightarrow p \text{ and } r, C \rightarrow q, D \rightarrow r$ |
| 25. (c) | 26. (d) | 27. (d) | 28. (d) | 82. $A \rightarrow q, s; B \rightarrow p, r, s, t; C \rightarrow t; D \rightarrow r$ |
| 29. (a) | 30. (d) | 31. (b) | 32. (b) | 83. $A \rightarrow p, B \rightarrow q, s; C \rightarrow q, r, s, t; D \rightarrow r$ |
| 33. (c) | 34. (b) | 35. (a) | 36. (c) | 84. $A \rightarrow p, q, s; B \rightarrow p, t; C \rightarrow r, D \rightarrow q, s$ |
| 37. (a) | 38. (c) | 39. (d) | 40. (a) | 85. $A \rightarrow p, q, s, B \rightarrow p, t; C \rightarrow q, r, s, t; D \rightarrow s$ |
| 41. (c) | 42. (b) | 43. (c) | 44. (a) | 86. $A \rightarrow r, B \rightarrow q, s; C \rightarrow r, s; D \rightarrow p, r$ |
| 45. (d) | 46. (a) | 47. (c) | 48. (b) | 87. $A \rightarrow q, B \rightarrow p, C \rightarrow r$ |
| 49. (c) | 50. (d) | 51. (d) | 52. (a) | 88. $A \rightarrow q, B \rightarrow p, C \rightarrow r, D \rightarrow s$ |
| 53. (a) | 54. (a) | 55. (d) | 56. (d) | 89. - 1 and 2 |
| 57. (b) | 58. (d) | 59. (c) | 61. (c) | 90. (4) |
| 61. (a) | 62. (c) | 63. (d) | 64. (c, d) | 91. 49.25 |
| 65. (c) | 66. 1523 | 67. (8) | 68. (3748) | 92. $\sqrt{3}$ |
| 69. 119 | 70. (b) | 71. (b) | 72. (c) | 93. (1) |
| 73. (a) | 74. (b) | 75. (a) | | 94. (3) |
| | | | | 95. (4) |

Hints & Solutions

1. Let $n(A)$ = Number of people read newspaper $A = 63\%$

$n(B)$ = Number of people read newspaper $B = 76\%$

and $n(A \cap B)$ = Number of people read both = $x\%$

$$\therefore n(A \cup B) = n(A) + n(B) - n(A \cap B)$$

$$\text{and } 76 \leq n(A \cup B) \leq 100 \Rightarrow 76 \leq 63 + 76 - x \leq 100$$

$$\Rightarrow 0 \leq 63 - x \leq 24 \Rightarrow 39 \leq x \leq 63$$

Hence, option (a) is correct.

2. Given equation

$$3^x(3^x - 1) + 2 = |3^x - 1| + |3^x - 2|$$

Let $3^x = t > 0, \forall x \in R$, so equation is

$$t^2 - t + 2 = |t - 1| + |t - 2| \quad \dots(i)$$

$$\therefore |t - 1| + |t - 2| = \begin{cases} 1 - t + 2 - t, & 0 < t \leq 1 \\ t - 1 + 2 - t, & 1 < t \leq 2 \\ t - 1 + t - 2, & t > 2 \end{cases}$$

$$= \begin{cases} 3 - 2t, & 0 < t \leq 1 \\ 1, & 1 < t \leq 2 \\ 2t - 3, & t > 2 \end{cases}$$

Now, **Case-I**

If $|t - 1| + |t - 2| = 3 - 2t$, for $0 < t \leq 1$

then $t^2 - t + 2 = 3 - 2t \Rightarrow t^2 + t - 1 = 0$

$$\Rightarrow t = \frac{-1 \pm \sqrt{5}}{2} = \frac{\pm\sqrt{5} - 1}{2}$$

$$\therefore \frac{\sqrt{5} - 1}{2} \in (0, 1]$$

$$\therefore t = \frac{\sqrt{5} - 1}{2} \text{ is one of the solution.}$$

Case-II

If $|t - 1| + |t - 2| = 1$, for $1 < t \leq 2$

$$\text{then } t^2 - t + 2 = 1$$

$\Rightarrow t^2 - t + 1 = 0$ have no real solution.

Case-III

If $|t - 1| + |t - 2| = 2t - 3$, for $t > 2$

$$\text{then } t^2 - t + 2 = 2t - 3$$

$\Rightarrow t^2 - 3t + 5 = 0$ have no real solution.

Since, S be the set of all real roots of the given equation, then S is a singleton set.

Hence, option (a) is correct.

3. From the truth table

P	Q	$P \vee Q$	$P \wedge Q$	$P \rightarrow Q$	$P \wedge (P \rightarrow Q)$	$P \wedge (P \vee Q)$	$P \vee (P \wedge Q)$
T	T	T	T	T	T	T	T
T	F	T	F	F	F	T	T
F	T	T	F	T	F	F	F
F	F	F	F	T	F	F	F

$P \wedge (P \rightarrow Q) \rightarrow Q$	$Q \rightarrow (P \wedge (P \rightarrow Q))$
T	T
T	T
T	F
T	T

$\therefore P \wedge (P \rightarrow Q) \rightarrow Q$ is a tautology.

Hence, option (a) is correct.

616 Miscellaneous

4. Given proposition $p \Rightarrow \sim(p \wedge (\sim q))$
 $= p \Rightarrow (\sim p \vee q)$
 $= (\sim p) \vee ((\sim p) \vee q)$ [by De Morgan Law]
 $= (\sim p) \vee q$

Hence, option (b) is correct.

5. Given boolean expression is
 $\sim(p \Rightarrow (\sim q))$
 $\equiv \sim((\sim p) \vee (\sim q))$ [$\because p \Rightarrow q \equiv \sim p \vee q$]
 $\equiv p \wedge q$

6. **Key Idea** Formula of standard deviation (σ), for n observations
 $= \sqrt{\frac{\sum x_i^2}{n} - \left(\frac{\sum x_i}{n}\right)^2}$

Given 10 observations are $x_1, x_2, x_3, \dots, x_{10}$

- $\therefore \frac{x_1 + x_2 + x_3 + x_4}{4} = 11$
 $\Rightarrow x_1 + x_2 + x_3 + x_4 = 44$... (i)
 and $\frac{x_5 + x_6 + x_7 + x_8 + x_9 + x_{10}}{6} = 16$
 $\Rightarrow x_5 + x_6 + x_7 + x_8 + x_9 + x_{10} = 96$... (ii)
 So, mean of given 10 observations $= \frac{44 + 96}{10} = \frac{140}{10} = 14$

Since, the sum of squares of all the observations = 2000
 $x_1^2 + x_2^2 + x_3^2 + \dots + x_{10}^2 = 2000$... (iii)

Now, $\sigma^2 = (\text{standard deviation})^2 = \frac{\sum x_i^2}{10} - \left(\frac{\sum x_i}{10}\right)^2$
 $= \frac{2000}{10} - (14)^2 = 200 - 196 = 4$

So, $\sigma = 2$

7. **Key Idea** Use formula:
 $p \rightarrow q = \sim p \vee q$

Given statement is

$$p \rightarrow (\sim q \vee r) = \sim p \vee (\sim q \vee r)$$

Now, from the options

- (a) When $p = T, q = T$ and $r = F$
 then $\sim p \vee (\sim q \vee r) = F \vee (F \vee F) = F$
 (b) When $p = T, q = F$ and $r = F$
 then $\sim p \vee (\sim q \vee r) = F \vee (T \vee F) = T$
 (c) When $p = T, q = F$ and $r = T$
 then $\sim p \vee (\sim q \vee r) = F \vee (T \vee T) = T$
 (d) When $p = F, q = T$ and $r = T$
 then $\sim p \vee (\sim q \vee r) = T \vee (F \vee T) = T$

8. **Key Idea** Use De-morgan's law, Distributive law and Identity law
 as $p \vee F \equiv p$

The given boolean expression is $\sim s \vee ((\sim r) \wedge s)$

Now, the negation of given boolean expression is

$$\sim(\sim s \vee ((\sim r) \wedge s))$$

$$\begin{aligned} &= s \wedge (\sim((\sim r) \wedge s)) && [\because \sim(p \wedge q) = \sim p \vee \sim q] \\ &= s \wedge (r \vee (\sim s)) && [\because \sim(p \vee q) = \sim p \wedge \sim q] \\ &= (s \wedge r) \vee (s \wedge (\sim s)) && [\because p \wedge (q \vee r) \equiv (p \wedge q) \vee (p \wedge r)] \\ &= (s \wedge r) && [\because p \wedge \sim p \equiv F] \end{aligned}$$

9. It is given that both mean and standard deviation of 50 observations $x_1, x_2, x_3, \dots, x_{50}$ are equal to 16,

So, mean $= \frac{\sum x_i}{50} = 16$... (i)

and standard deviation $= \sqrt{\frac{\sum x_i^2}{50} - \left(\frac{\sum x_i}{50}\right)^2} = 16$

$$\Rightarrow \frac{\sum x_i^2}{50} - (16)^2 = (16)^2$$

$$\Rightarrow \frac{\sum x_i^2}{50} = 2 \times 256 = 512$$
 ... (ii)

Now, mean of $(x_1 - 4)^2, (x_2 - 4)^2, \dots, (x_{50} - 4)^2$

$$= \frac{\sum (x_i - 4)^2}{50} = \frac{\sum (x_i^2 - 8x_i + 16)}{50}$$

$$= \frac{\sum x_i^2}{50} - 8\left(\frac{\sum x_i}{50}\right) + \frac{16}{50} \sum 1$$

$$= 512 - (8 \times 16) + \left(\frac{16}{50} \times 50\right)$$
 [from Eqs. (i) and (ii)]

$$= 512 - 128 + 16 = 400$$

10. Option (a) $(p \vee q) \vee (p \vee (\sim q))$

$\equiv p \vee (q \vee \sim q)$ is tautology,
 $[\because q \vee (\sim q) \equiv T \text{ and } p \vee T \equiv T]$

Option (b)

$$(p \wedge q) \vee (p \wedge (\sim q)) \equiv p \wedge (q \vee \sim q)$$

not a tautology,

$$[\because q \vee \sim q \equiv T \text{ and } p \wedge T \equiv p]$$

Option (c)

$$(p \vee q) \wedge (p \vee (\sim q)) \equiv p \vee (q \wedge \sim q)$$

not a tautology [$\because q \wedge \sim q \equiv F$ and $p \vee F \equiv p$]

Option (d)

$(p \vee q) \wedge ((\sim p) \vee (\sim q)) \equiv (p \vee q) \wedge (\sim(p \wedge q))$
 not a tautology.

11. **Key Idea** Use $\sum_{i=1}^n f_i$ = Number of students;
 and Mean $(\bar{x}) = \frac{\sum f_i x_i}{\sum f_i}$

The given frequency distribution, for some $x \in R$, of marks obtained by 20 students is

Marks	2	3	5	7
Frequency	$(x + 1)^2$	$2x - 5$	$x^2 - 3x$	x

\therefore Number of students = 20 = $\sum f_i$

$$\Rightarrow (x + 1)^2 + (2x - 5) + (x^2 - 3x) + x = 20$$

$$\Rightarrow (x^2 + 2x + 1) + (2x - 5) + (x^2 - 3x) + x = 20$$

$$\Rightarrow 2x^2 + 2x - 24 = 0$$

$$\Rightarrow x^2 + x - 12 = 0$$

$$\Rightarrow (x + 4)(x - 3) = 0 \Rightarrow x = 3$$

[as $x > 0$]

Now, mean $(\bar{x}) = \frac{\sum f_i x_i}{\sum f_i}$

$$= \frac{2(x+1)^2 + 3(2x-5) + 5(x^2-3x) + 7x}{20}$$

$$= \frac{2(4)^2 + 3(1) + 5(0) + 7(3)}{20} = \frac{32 + 3 + 21}{20} = \frac{56}{20} = 2.8$$

Hence, option (b) is correct.

12. Let the population of city is 100.

Then, $n(A) = 25$, $n(B) = 20$ and $n(A \cap B) = 8$

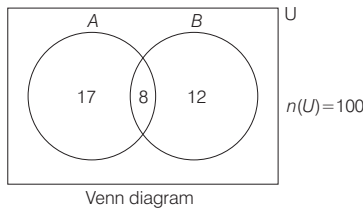

So, $n(A \cap \bar{B}) = 17$ and $n(\bar{A} \cap B) = 12$
 According to the question, Percentage of the population who look into advertisement is

$$= \left[\frac{30}{100} \times n(A \cap \bar{B}) \right] + \left[\frac{40}{100} \times n(\bar{A} \cap B) \right] + \left[\frac{50}{100} \times n(A \cap B) \right]$$

$$= \left(\frac{30}{100} \times 17 \right) + \left(\frac{40}{100} \times 12 \right) + \left(\frac{50}{100} \times 8 \right)$$

$$= 5.1 + 4.8 + 4 = 13.9$$

13. Given ten numbers are 10, 22, 26, 29, 34, x, 42, 67, 70, y and their mean = 42

$$\therefore \frac{10 + 22 + 26 + 29 + 34 + x + 42 + 67 + 70 + y}{10} = 42$$

$$\Rightarrow \frac{300 + x + y}{10} = 42$$

$$\Rightarrow x + y = 120 \quad \dots(i)$$

and their median (arranged numbers are in increasing order) = 35

$$\Rightarrow \frac{34 + x}{2} = 35$$

$$\Rightarrow 34 + x = 70$$

$$\Rightarrow x = 36$$

On substituting $x = 36$ in Eq. (i), we get

$$\Rightarrow 36 + y = 120$$

$$\Rightarrow y = 84$$

$$\therefore \frac{y}{x} = \frac{84}{36} = \frac{7}{3}$$

14. Given statement $p \Rightarrow (q \vee r)$ is false.

$\therefore p \rightarrow (q \vee r) = (\sim p) \vee (q \vee r)$
 Now, by trial and error method, if truth value of p is T, q is F and r is F, then truth value of $(q \vee r)$ is F.

So, truth value of $[(\sim p) \vee (q \vee r)]$ is false.

Thus, if truth value of p, q, r are T, F, F, then the statement $p \rightarrow (q \vee r)$ is false.

15. $\therefore p \vee ((\sim p) \wedge q)$

$$= (p \vee (\sim p)) \wedge (p \vee q) \quad [\text{by Distributive law}]$$

$$= p \vee q \quad [\because p \vee (\sim p) \text{ is tautology}]$$
 So negation of $p \vee ((\sim p) \wedge q)$

$$= \sim [p \vee ((\sim p) \wedge q)] = \sim (p \vee q)$$

$$= (\sim p) \wedge (\sim q) \quad [\text{by Demorgan's law}]$$

16. Given observations are $-1, 0, 1$ and k .

Also, standard deviation of these four observations = $\sqrt{5}$

$$\therefore \sqrt{\frac{(-1)^2 + (0)^2 + (1)^2 + k^2}{4} - \left(\frac{-1 + 0 + 1 + k}{4} \right)^2} = \sqrt{5}$$

[\because if x_1, x_2, \dots, x_n are n observation, then standard deviation = $\sqrt{\frac{1}{n} \sum_{i=1}^n x_i^2 - \left(\frac{1}{n} \sum_{i=1}^n x_i \right)^2}$]

$$\Rightarrow \frac{2 + k^2}{4} - \frac{k^2}{16} = 5 \quad [\text{squaring both sides}]$$

$$\Rightarrow \frac{8 + 4k^2 - k^2}{16} = 5 \Rightarrow \frac{8 + 3k^2}{16} = 5$$

$$\Rightarrow 8 + 3k^2 = 80 \Rightarrow 3k^2 = 72$$

$$\Rightarrow k^2 = 24 \Rightarrow k = 2\sqrt{6} \text{ or } -2\sqrt{6}$$

$$\Rightarrow k = 2\sqrt{6} \quad [\because k > 0]$$

17. Let the marks in sixth tests is 'x', so

$$\text{mean} = \frac{41 + 45 + 43 + 54 + 57 + x}{6} = 48 \text{ (given)}$$

$$\Rightarrow \frac{240 + x}{6} = 48 \Rightarrow 40 + \frac{x}{6} = 48$$

$$\Rightarrow \frac{x}{6} = 8 \Rightarrow x = 48$$

Now, standard deviation of these marks

$$= \sqrt{\frac{41^2 + 45^2 + 43^2 + 54^2 + 57^2 + 48^2}{6} - 48^2}$$

[\because standard deviation (SD) = $\sqrt{\frac{\sum x_i^2}{n} - (\bar{x})^2}$]

$$= \sqrt{\frac{(41^2 - 48^2) + (45^2 - 48^2) + (43^2 - 48^2) + (54^2 - 48^2) + (57^2 - 48^2)}{6}}$$

$$= \sqrt{\frac{(-7 \times 89) + (-3 \times 93) + (-5 \times 91) + (6 \times 102) + (9 \times 105)}{6}}$$

$$= \sqrt{\frac{945 + 612 - 455 - 279 - 623}{6}}$$

$$= \sqrt{\frac{1557 - 1357}{6}} = \sqrt{\frac{200}{6}} = \sqrt{\frac{100}{3}} = \frac{10}{\sqrt{3}}$$

18. $(p \wedge q) \rightarrow (\sim p) \vee q$

$$\equiv (\sim (p \wedge q)) \vee ((\sim p) \vee q)$$

$$\equiv ((\sim p) \vee (\sim q)) \vee ((\sim p) \vee q)$$

$$\equiv (\sim p) \vee ((\sim q) \vee q) \quad [\because (\sim p) \vee (\sim p) \equiv \sim p]$$

$$\equiv (\sim p) \vee T \quad [\because \sim q \vee q \equiv T]$$

$$\equiv T$$

So, it is a tautology [$\because ((\sim q) \vee q)$ is tautology]

618 Miscellaneous

- (b) $(p \wedge q) \rightarrow p \equiv (p \wedge q) \vee p$
 $\equiv ((\sim p) \vee (\sim q)) \vee p$
 $[\because (\sim(p \wedge q)) \equiv (\sim p) \vee (\sim q)]$
 $\equiv (\sim p \vee p) \vee (\sim q)$ is tautology.
 $[\because \sim p \vee p$ is a tautology and $(\sim q) \vee T \equiv T]$
- (c) $\because p \rightarrow (p \vee q) \equiv (\sim p) \vee (p \vee q)$
 $[\because p \rightarrow q$ is equivalent to $(\sim p \vee q)]$
 $\equiv (\sim p \vee p) \vee q$ is tautology.
 $[\because (\sim p \vee p)$ is tautology and $q \vee T \equiv T]$
- (d) $(p \vee q) \rightarrow (p \vee (\sim q))$
 $\equiv (\sim(p \vee q)) \vee (p \vee (\sim q))$
 $\equiv ((\sim p) \wedge (\sim q)) \vee (p \vee (\sim q))$
 $\equiv (p \vee (\sim q)) \vee ((\sim p) \wedge (\sim q))$
 $\equiv (p \vee (\sim q) \vee (\sim p)) \wedge (p \vee (\sim q) \vee (\sim q))$
 $\equiv (T \vee (\sim q)) \wedge (p \wedge (\sim q))$
 $\equiv T \wedge (p \wedge (\sim q))$
 $\equiv p \wedge (\sim q)$, which is not a tautology.

19. The natural numbers between 100 and 200 are 101, 102, 103, ..., 199.

Since, $91 = 13 \times 7$, so the natural numbers between 100 and 200 whose HCF with 91 is more than 1 are the numbers which are either divisible by 7 or 13.

So, the required sum of numbers between 100 and 200 = (sum of numbers divisible by 7) + (sum of numbers divisible by 13) - (sum of numbers divisible by 91)

$$= \sum_{r=1}^{14} (98 + 7r) + \sum_{r=1}^8 (91 + 13r) - (182)$$

$$= (98 \times 14) + 7 \left(\frac{14 \times 15}{2} \right) + (91 \times 8) + 13 \left(\frac{8 \times 9}{2} \right) - (182)$$

$$= 1372 + 735 + 728 + 468 - 182$$

$$= 3303 - 182 = 3121$$

20. Let the remaining two observations are a and b . According to the question,

$$\text{Mean} = \frac{2 + 4 + 10 + 12 + 14 + a + b}{7} = 8$$

$$\Rightarrow 42 + a + b = 56$$

$$\Rightarrow a + b = 14 \quad \dots(i)$$

and variance

$$= \frac{a^2 + b^2 + 4 + 16 + 100 + 144 + 196}{7} - 8^2 = 16$$

$$\Rightarrow \frac{a^2 + b^2 + 460}{7} - 64 = 16$$

$$\Rightarrow \frac{a^2 + b^2 + 460}{7} = 80$$

$$\Rightarrow a^2 + b^2 + 460 = 560$$

$$\Rightarrow a^2 + b^2 = 100 \quad \dots(ii)$$

We know that,

$$(a + b)^2 = (a^2 + b^2) + 2ab$$

$$\Rightarrow (14)^2 = 100 + 2ab \quad [\text{from Eqs. (i) and (ii)}]$$

$$\Rightarrow 196 = 100 + 2ab$$

$$\Rightarrow 2ab = 96$$

$$\Rightarrow ab = 48$$

So, product of remaining two observations is 48.

21. Given digits are 1, 1, 2, 2, 2, 2, 3, 4, 4.

According to the question, odd numbers 1, 1, 3 should occur at even places only.

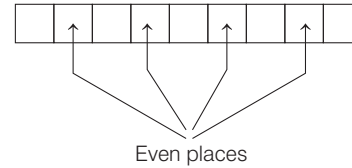

\therefore The number of ways to arrange odd numbers at even places are ${}^4C_3 \times \frac{3!}{2!}$

and the number of ways to arrange remaining even numbers are $\frac{6!}{4!2!}$

So, total number of 9-digit numbers, that can be formed using the given digits are

$${}^4C_3 \times \frac{3!}{2!} \times \frac{6!}{4!2!} = 4 \times 3 \times 15 = 180$$

22. Given statement is "If you are born in India, then you are a citizen of India".

Now, let statement p : you are born in India and q : you are citizen of India.

Then, given statement, "If you are born in India then you are a citizen of India" is equivalent to $p \Rightarrow q$.

\therefore The contrapositive of statement $p \Rightarrow q$ is $\sim q \Rightarrow \sim p$.

\therefore The contrapositive of the given statement is "If you are not a citizen of India, then you are not born in India."

23. Given mean $\bar{x} = 4$

$$\text{variance } \sigma^2 = 5.20$$

and numbers of observation $n = 5$

Let $x_1 = 3, x_2 = 4, x_3 = 4$ and x_4, x_5 be the five observations

$$\text{So, } \sum_{i=1}^5 x_i = 5 \cdot \bar{x} = 5 \times 4 = 20$$

$$\Rightarrow x_1 + x_2 + x_3 + x_4 + x_5 = 20$$

$$\Rightarrow 3 + 4 + 4 + x_4 + x_5 = 20$$

$$\Rightarrow x_4 + x_5 = 9 \quad \dots(i)$$

$$\text{Now, variance } \sigma^2 = \frac{\sum_{i=1}^5 x_i^2}{5} - (\bar{x})^2$$

$$\Rightarrow \frac{x_1^2 + x_2^2 + x_3^2 + x_4^2 + x_5^2}{5} - (4)^2 = 5.20$$

$$\Rightarrow \frac{9 + 16 + 16 + x_4^2 + x_5^2}{5} = 16 + 5.20$$

$$\Rightarrow 41 + x_4^2 + x_5^2 = 5 \times 21.20$$

$$\Rightarrow x_4^2 + x_5^2 = 106 - 41$$

$$\Rightarrow x_4^2 + x_5^2 = 65 \quad \dots(ii)$$

$$\therefore (x_4 + x_5)^2 = x_4^2 + x_5^2 + 2x_4x_5$$

$$\therefore 81 = 65 + 2x_4x_5 \quad [\text{from Eqs. (i) and (ii)}]$$

$$\Rightarrow 16 = 2x_4x_5$$

$$\Rightarrow x_4x_5 = 8 \quad \dots(iii)$$

Now, $(|x_4 - x_5|)^2 = x_4^2 + x_5^2 - 2x_4x_5$
 $= 65 - 16$ [from Eqs. (ii) and (iii)]
 $= 49$
 $\Rightarrow |x_4 - x_5| = 7$

24. Let C and S represent the set of students who opted for NCC and NSS respectively.

Then, $n(C) = 40, n(S) = 30, n(C \cap S) = 20$
 and $n(U) = 60$
 Now, $n(\overline{C \cup S}) = n(\overline{C \cup S})$
 $= n(U) - n(C \cup S)$
 $= 60 - [n(C) + n(S) - n(C \cap S)]$
 $= 60 - [40 + 30 - 20] = 10$

So, required probability $= \frac{10}{60} = \frac{1}{6}$

25. Given, set $A = \{x \in Z : 2^{(x+2)(x^2-5x+6)} = 1\}$

Consider, $2^{(x+2)(x^2-5x+6)} = 1 = 2^0$
 $\Rightarrow (x+2)(x-3)(x-2) = 0$
 $\Rightarrow x = -2, 2, 3$
 $\Rightarrow A = \{-2, 2, 3\}$

Also, we have set $B = \{x \in Z : -3 < 2x - 1 < 9\}$

Consider, $-3 < 2x - 1 < 9, x \in Z$
 $\Rightarrow -2 < 2x < 10, x \in Z$
 $\Rightarrow -1 < x < 5, x \in Z$
 $\Rightarrow B = \{0, 1, 2, 3, 4\}$

So, $A \times B$ has 15 elements.

\therefore Number of subsets of $A \times B = 2^{15}$.

[\because If $n(A) = m$, the number of possible subsets $= 2^m$]

26. Since, the expression

$p \rightarrow q \equiv \sim p \vee q$

So, $\sim p \rightarrow q \equiv p \vee q$

and therefore $\sim(\sim p \rightarrow q) \equiv \sim(p \vee q)$

$\equiv (\sim p) \wedge (\sim q)$ [by De Morgan's law]

27. Let the given Boolean expression

$((p \wedge q) \vee (p \vee \sim q)) \wedge (\sim p \wedge \sim q) \equiv r$

Now, let us construct the following truth table

p	q	$\sim p$	$\sim q$	$p \wedge q$	$p \vee \sim q$	$\sim p \wedge \sim q$	$\frac{(p \wedge q) \vee (p \vee \sim q)}{(p \vee \sim q)}$	r
T	T	F	F	T	T	F	T	F
T	F	F	T	F	T	F	T	F
F	T	T	F	F	F	F	F	F
F	F	T	T	F	T	T	T	T

Clearly, $r \equiv \sim p \wedge \sim q$

28. Let the 50 observations are $x_1, x_2, x_3, \dots, x_{50}$.

Now, deviations of these observations from 30 are $(x_1 - 30), (x_2 - 30), (x_3 - 30), \dots, (x_{50} - 30)$

$\therefore \sum_{i=1}^{50} (x_i - 30) = 50$ (given)

$\Rightarrow \sum_{i=1}^{50} x_i - (30 \times 50) = 50$

$\Rightarrow \sum_{i=1}^{50} x_i = 50(30 + 1) = 50 \times 31$

\therefore Mean of 50 observations $= (\bar{x}) = \frac{\sum_{i=1}^{50} x_i}{50} = 31$

29. Given, set $S = \{1, 2, 3, \dots, 100\}$.

Total number of non-empty subsets of ' S ' $= 2^{100} - 1$

Now, numbers of non-empty subsets of ' S ' in which only odd numbers $\{1, 3, 5, \dots, 99\}$

occurs $= 2^{50} - 1$

So, the required number of non-empty subsets of ' S ' such that product of elements is even.

$= (2^{100} - 1) - (2^{50} - 1)$
 $= 2^{100} - 2^{50} = 2^{50}(2^{50} - 1)$

30. Number of white balls $= 30$

and number of red balls $= 10$

Let p = probability of success in a trial = probability of getting a white ball in a trial $= \frac{30}{40} = \frac{3}{4}$.

and q = probability of failure in a trial

$= 1 - p = 1 - \frac{3}{4} = \frac{1}{4}$

Here, n = number of trials $= 16$.

Clearly, X follows binomial distribution with parameter $n = 16$ and $p = \frac{3}{4}$.

\therefore Mean of $X = np, = 16 \cdot \frac{3}{4} = 12$

and variance of $X = npq = 16 \cdot \frac{3}{4} \cdot \frac{1}{4} = 3$

Now, $\frac{\text{mean of } X}{\text{standard deviation of } X} = \frac{12}{\sqrt{3}} = 4\sqrt{3}$

[\because SD $= \sqrt{\text{variance}}$]

31. We know that, contrapositive of $p \rightarrow q$ is $\sim q \rightarrow \sim p$

Therefore, the contrapositive of the given statement is "If the squares of two numbers are equal, then the numbers are equal".

32. Given, $(p \wedge q) \leftrightarrow r$ is true. This is possible under two cases

Case I When both $p \wedge q$ and r are true, which is not possible because q is false.

Case II When both $(p \wedge q)$ and r are false.

$\Rightarrow p \equiv \text{T or F}; q \equiv \text{F}, r \equiv \text{F}$

In this case,

(a) $p \vee r$ is T or F

(b) $(p \wedge r) \rightarrow (p \vee r)$ is $\text{F} \rightarrow (\text{T or F})$, which always result in T.

(c) $(p \vee r) \rightarrow (p \wedge r)$ is $(\text{T or F}) \rightarrow \text{F}$, which may be T or F.

(d) $p \wedge r$ is F.

620 Miscellaneous

33. We know,

$$\begin{aligned} \sigma^2 &= \frac{\sum x^2}{n} - \mu^2 \\ &= \frac{10\left(\frac{1}{2} - d\right)^2 + 10 \times \frac{1}{4} + 10\left(\frac{1}{2} + d\right)^2}{30} \\ &\quad - \left[\frac{10\left(\frac{1}{2} - d\right) + 10 \times \frac{1}{2} + 10\left(\frac{1}{2} + d\right)}{30} \right]^2 \quad \left[\because \mu = \frac{\sum x_i}{n} \right] \\ &= \frac{20\left(\frac{1}{4} + d^2\right) + 5/2}{30} - \left(\frac{1}{4}\right)^2 \\ &= \frac{\frac{15}{2} + 20d^2}{30} - \frac{1}{4} = \frac{1}{4} + \frac{2d^2}{3} - \frac{1}{4} = \frac{2}{3}d^2 \\ \therefore \frac{2}{3}d^2 &= \frac{4}{3} \Rightarrow d^2 = 2 \Rightarrow |d| = \sqrt{2} \end{aligned}$$

34. Since, the statements

- P : 5 is a prime number, is true statement.
- Q : 7 is a factor of 192, is false statement
- and R : LCM of 5 and 7 is 35, is true statement.

So, truth value of

P is T, Q is F, R is T

Now let us check all the options.

P	Q	R	$\sim P$	$\sim Q$	$\sim R$	$P \wedge Q$	$Q \wedge R$	$\sim Q \wedge R$
T	F	T	F	T	F	F	F	T
$(P \wedge Q) \vee (\sim R)$			$P \vee (\sim Q \wedge R)$		$(\sim P) \vee (Q \wedge R)$		$(\sim P) \wedge (\sim Q \wedge R)$	
F			T		F		F	

Clearly, the truth value of $P \vee (\sim Q \wedge R)$ is T.

35. Let 1, 3, 8, x and y be the five observations.

Then, mean $\bar{x} = \frac{\sum x_i}{n}$

$$\Rightarrow \bar{x} = \frac{1 + 3 + 8 + x + y}{5} = 5 \quad \text{(given)}$$

$$\Rightarrow x + y = 25 - 12 = 13$$

$$\Rightarrow x + y = 13 \quad \dots(i)$$

and variance $= \sigma^2 = \frac{\sum (x_i - \bar{x})^2}{n}$

$$= \frac{\left[(1-5)^2 + (3-5)^2 + (8-5)^2 + (x-5)^2 + (y-5)^2 \right]}{5} = 9.2 \quad \text{(given)}$$

$$\Rightarrow 16 + 4 + 9 + (x^2 - 10x + 25) + (y^2 - 10y + 25) = 46$$

$$\Rightarrow x^2 + y^2 - 10(x + y) = 46 - 79$$

$$\Rightarrow x^2 + y^2 - 10 \times 13 = -33 \quad [\because x + y = 13]$$

$$\Rightarrow x^2 + y^2 = 97 \quad \dots(ii)$$

Let $\frac{y}{x} = t \Rightarrow y = xt$

Putting $y = xt$ in Eq. (i), we get

$$\begin{aligned} x(1 + t) &= 13 \\ \Rightarrow x^2(1 + t)^2 &= 169 \quad \dots(iii) \end{aligned}$$

Putting $y = xt$ in Eq. (ii), we get

$$x^2(1 + t^2) = 97 \quad \dots(iv)$$

Dividing Eq. (iii) by Eq. (iv), we get

$$\begin{aligned} \frac{x^2(1 + t)^2}{x^2(1 + t^2)} &= \frac{169}{97} \\ \Rightarrow 97(t^2 + 2t + 1) &= 169(1 + t^2) \\ \Rightarrow (169 - 97)t^2 - 194t + (169 - 97) &= 0 \\ \Rightarrow 36t^2 - 97t + 36 &= 0 \\ \Rightarrow (4t - 9)(9t - 4) &= 0 \\ \Rightarrow t &= \frac{9}{4} \\ \text{or } t &= \frac{4}{9} \end{aligned}$$

36.

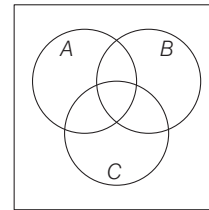

Let A be the set of even numbered students then $n(A) = \left[\frac{140}{2} \right] = 70$ ([.] denotes greatest integer function)

Let B be the set of those students whose number is divisible by 3,

then $n(B) = \left[\frac{140}{3} \right] = 46$

([.] denotes greatest integer function)

Let C be the set of those students whose number is divisible by 5,

then $n(C) = \left[\frac{140}{5} \right] = 28$

([.] denotes greatest integer function)

Now, $n(A \cap B) = \left[\frac{140}{6} \right] = 23$

(numbers divisible by both 2 and 3)

$n(B \cap C) = \left[\frac{140}{15} \right] = 9$

(numbers divisible by both 3 and 5)

$n(C \cap A) = \left[\frac{140}{10} \right] = 14$

(numbers divisible by both 2 and 5)

$n(A \cap B \cap C) = \left[\frac{140}{30} \right] = 4$

(numbers divisible by 2, 3 and 5)

$$\begin{aligned} &\text{and } n(A \cup B \cup C) \\ &= \Sigma n(A) - \Sigma n(A \cap B) + n(A \cap B \cap C) \\ &= (70 + 46 + 28) - (23 + 9 + 14) + 4 = 102 \end{aligned}$$

∴ Number of students who did not opt any of the three courses

$$= \text{Total students} - n(A \cup B \cup C) = 140 - 102 = 38$$

37. Given statement is “ $P(n) : n^2 - n + 41$ is prime”.

$$\begin{aligned} \text{Clearly } P(3) : 3^2 - 3 + 41 &= 9 - 3 + 41 \\ &= 47 \text{ which is a prime number.} \end{aligned}$$

$$\begin{aligned} \text{and } P(5) : 5^2 - 5 + 41 &= 25 - 5 + 41 = 61, \\ \text{which is also a prime number.} \end{aligned}$$

∴ Both $P(3)$ and $P(5)$ are true.

38. Clearly, $[\sim(\sim p \vee q) \vee (p \wedge r)] \wedge (\sim q \wedge r)$

$$\begin{aligned} &\equiv [(p \wedge \sim q) \vee (p \wedge r)] \wedge (\sim q \wedge r) \\ &\quad (\because \sim(\sim p \vee q) \equiv \sim(\sim p) \wedge \sim q \equiv p \wedge \sim q \\ &\quad \text{by De Morgan's law}) \\ &\equiv [p \wedge (\sim q \vee r)] \wedge (\sim q \wedge r) \quad (\text{distributive law}) \\ &\equiv p \wedge [(\sim q \vee r) \wedge (\sim q \wedge r)] \quad (\text{associative law}) \\ &\equiv p \wedge [(\sim q \wedge r) \wedge (\sim q \vee r)] \quad (\text{commutative law}) \\ &\equiv p \wedge \{(\sim q \wedge r) \wedge (\sim q)\} \wedge \{(\sim q \wedge r) \wedge r\} \\ &\quad (\text{distributive law}) \\ &\equiv p \wedge [(\sim q \wedge r) \vee (\sim q \wedge r)] \quad (\text{idempotent law}) \\ &\equiv p \wedge [\sim q \wedge r] \quad (\text{idempotent law}) \\ &\equiv p \wedge \sim q \wedge r \equiv (p \wedge r) \wedge (\sim q) \quad (\text{associative law}) \end{aligned}$$

39. We have,

$$\sum_{i=1}^n (x_i + 1)^2 = 9n \quad \dots(i)$$

$$\text{and} \quad \sum_{i=1}^n (x_i - 1)^2 = 5n \quad \dots(ii)$$

On subtracting Eq. (ii) from Eq. (i) is, we get

$$\Rightarrow \sum_{i=1}^n \{(x_i + 1)^2 - (x_i - 1)^2\} = 4n$$

$$\Rightarrow \sum_{i=1}^n 4x_i = 4n \Rightarrow \sum_{i=1}^n x_i = n$$

$$\Rightarrow \frac{\sum_{i=1}^n x_i}{n} = 1 \Rightarrow \text{mean}(\bar{x}) = 1$$

$$\text{Now, standard deviation} = \sqrt{\frac{\sum_{i=1}^n (x_i - \bar{x})^2}{n}}$$

$$= \sqrt{\frac{\sum_{i=1}^n (x_i - 1)^2}{n}} = \sqrt{\frac{5n}{n}} = \sqrt{5}$$

40. Let us check all the options

(A) Consider, $\oplus = \wedge$ and $\cdot = \vee$.

In that case, we get

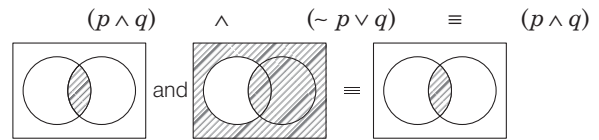

[take $\vee \approx \cup$ and $\wedge \approx \cap$]

(B) Consider, $\oplus = \wedge$ and $\cdot = \vee$.

In that case, we get

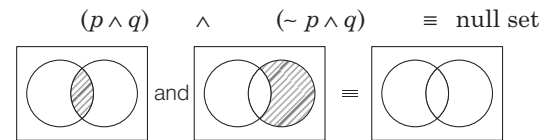

(C) Consider, $\oplus = \vee$ and $\cdot = \wedge$.

In that case, we get

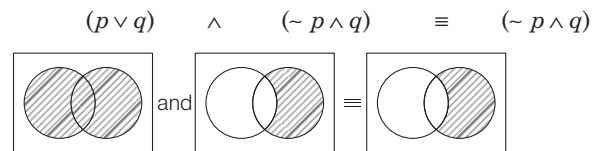

(D) Consider, $\oplus = \vee$ and $\odot = \vee$.

In that case, we get

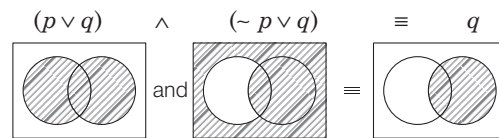

41. Let x_1, x_2, x_3, x_4, x_5 be the heights of five students. Then, we have

$$\text{Mean, } \bar{x} = \frac{\sum_{i=1}^5 x_i}{5} = 150 \Rightarrow \sum_{i=1}^5 x_i = 750 \quad \dots(i)$$

$$\text{and} \quad \text{variance} = \frac{\sum_{i=1}^5 x_i^2}{n} - (\bar{x})^2$$

$$\Rightarrow \frac{\sum_{i=1}^5 x_i^2}{5} - (150)^2 = 18 \Rightarrow \sum_{i=1}^5 x_i^2 = 112590 \quad \dots(ii)$$

$$\text{Now, new mean} = \frac{\sum_{i=1}^6 x_i}{6}$$

$$= \frac{\sum_{i=1}^5 x_i + 156}{6} = \frac{750 + 156}{6} \quad [\text{using Eq. (i)}]$$

$$\Rightarrow \bar{x}_{\text{new}} = 151$$

and new variance

$$= \frac{\sum_{i=1}^6 x_i^2}{6} - (\bar{x}_{\text{new}})^2$$

$$= \frac{\sum_{i=1}^5 x_i^2 + (156)^2}{6} - (151)^2$$

$$= \frac{112590 + (156)^2}{6} - (151)^2 \quad [\text{using Eq. (ii)}]$$

$$= 22821 - 22801 = 20$$

622 Miscellaneous

42. We have,

$$\begin{aligned} & |a-5| < 1 \text{ and } |b-5| < 1 \\ \therefore & -1 < a-5 < 1 \text{ and } -1 < b-5 < 1 \\ \Rightarrow & 4 < a < 6 \text{ and } 4 < b < 6 \\ \text{Now,} & 4(a-6)^2 + 9(b-5)^2 \leq 36 \\ \Rightarrow & \frac{(a-6)^2}{9} + \frac{(b-5)^2}{4} \leq 1 \end{aligned}$$

Taking axes as a -axis and b -axis

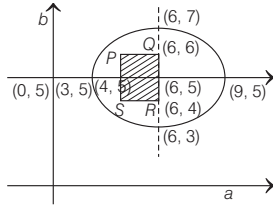

The set A represents square $PQRS$ inside set B representing ellipse and hence $A \subset B$.

43. **Key idea** Standard deviation is remain unchanged, if observations are added or subtracted by a fixed number

We have,

$$\begin{aligned} \sum_{i=1}^9 (x_i - 5) &= 9 \text{ and } \sum_{i=1}^9 (x_i - 5)^2 = 45 \\ SD &= \sqrt{\frac{\sum_{i=1}^9 (x_i - 5)^2}{9} - \left(\frac{\sum_{i=1}^9 (x_i - 5)}{9}\right)^2} \\ \Rightarrow SD &= \sqrt{\frac{45}{9} - \left(\frac{9}{9}\right)^2} \Rightarrow SD = \sqrt{5 - 1} = \sqrt{4} = 2 \end{aligned}$$

44. **Key idea** Use De-Morgan's and distributive law.

$$\begin{aligned} \text{We have, } & \sim(p \vee q) \vee (\sim p \wedge q) \\ & \equiv (\sim p \wedge \sim q) \vee (\sim p \wedge q) \\ & [\because \text{By De-Morgan's law } \sim(p \vee q) = (\sim p \wedge \sim q)] \\ \equiv & \sim p \wedge (\sim q \vee q) \quad [\text{By distributive law}] \\ \equiv & \sim p \wedge t \quad [\sim q \vee q = t] \\ \equiv & \sim p \end{aligned}$$

$$\begin{aligned} 45. \therefore \Delta &= \begin{vmatrix} 1 & 1 & 1 \\ 1 & a & 1 \\ a & b & 1 \end{vmatrix} = 1(a-b) - 1(1-a) + 1(b-a^2) \\ &= -(a-1)^2 \end{aligned}$$

$$\Delta_1 = \begin{vmatrix} 1 & 1 & 1 \\ 1 & a & 1 \\ 0 & b & 1 \end{vmatrix} = 1(a-b) - 1(1) + 1(b) = -(a-1)$$

$$\Delta_2 = \begin{vmatrix} 1 & 1 & 1 \\ 1 & 1 & 1 \\ a & 0 & 1 \end{vmatrix} = 1(1) - 1(1-a) + 1(0-a) = 0$$

$$\text{and } \Delta_3 = \begin{vmatrix} 1 & 1 & 1 \\ 1 & a & 1 \\ a & b & 0 \end{vmatrix} = 1(-b) - 1(-a) + 1(b-a^2)$$

$$= -a(a-1)$$

For $a = 1$

$$\Delta = \Delta_1 = \Delta_2 = \Delta_3 = 0$$

Δ for $b = 1$ only

$$x + y + z = 1,$$

$$x + y + z = 1$$

and $x + y + z = 0$

i.e. no solution

(\because RHS is not equal)

Hence, for no solution $b = 1$ only

46. The truth table of the given expression is given below :

p	q	$x \equiv p \rightarrow q$	$\sim p$	$\sim p \rightarrow q$	$y \equiv (\sim p \rightarrow q) \rightarrow q$	$x \rightarrow y$
T	T	T	F	T	T	T
T	F	F	F	T	F	T
F	T	T	T	T	T	T
F	F	T	T	F	T	T

Hence, it is a tautology.

47. We have, $f(x) + 2f\left(\frac{1}{x}\right) = 3x, x \neq 0$... (i)

On replacing x by $\frac{1}{x}$ in the above equation, we get

$$\begin{aligned} f\left(\frac{1}{x}\right) + 2f(x) &= \frac{3}{x} \\ \Rightarrow 2f(x) + f\left(\frac{1}{x}\right) &= \frac{3}{x} \quad \dots \text{(ii)} \end{aligned}$$

On multiplying Eq. (ii) by 2 and subtracting Eq. (i) from Eq. (ii), we get

$$\begin{aligned} 4f(x) + 2f\left(\frac{1}{x}\right) &= \frac{6}{x} \\ \underline{f(x) + 2f\left(\frac{1}{x}\right) = 3x} & \quad \underline{\hspace{1.5cm}} \\ 3f(x) &= \frac{6}{x} - 3x \\ \Rightarrow f(x) &= \frac{2}{x} - x \end{aligned}$$

Now, consider

$$\begin{aligned} f(x) &= f(-x) \\ \Rightarrow \frac{2}{x} - x &= -\frac{2}{x} + x \Rightarrow \frac{4}{x} = 2x \\ \Rightarrow 2x^2 &= 4 \Rightarrow x^2 = 2 \\ \Rightarrow x &= \pm \sqrt{2} \end{aligned}$$

Hence, S contains exactly two elements.

48. We know that, if x_1, x_2, \dots, x_n are n observations, then their standard deviation is given by

$$\sqrt{\frac{1}{n} \sum x_i^2 - \left(\frac{\sum x_i}{n}\right)^2}$$

$$\text{We have, } (3.5)^2 = \frac{(2^2 + 3^2 + a^2 + 11^2)}{4} - \left(\frac{2+3+a+11}{4}\right)^2$$

$$\Rightarrow \frac{49}{4} = \frac{4+9+a^2+121}{4} - \left(\frac{16+a}{4}\right)^2$$

$$\begin{aligned} \Rightarrow \frac{49}{4} &= \frac{134 + a^2}{4} - \frac{256 + a^2 + 32a}{16} \\ \Rightarrow \frac{49}{4} &= \frac{4a^2 + 536 - 256 - a^2 - 32a}{16} \\ \Rightarrow 49 \times 4 &= 3a^2 - 32a + 280 \Rightarrow 3a^2 - 32a + 84 = 0 \end{aligned}$$

49. Consider, $(p \wedge \sim q) \vee q \vee (\sim p \wedge q)$

$$\begin{aligned} &\equiv [(p \wedge \sim q) \vee q] \vee (\sim p \wedge q) \\ &\equiv [(p \vee q) \wedge (\sim q \vee q)] \vee (\sim p \wedge q) \\ &\equiv [(p \vee q) \wedge t] \vee (\sim p \wedge q) \\ &\equiv (p \vee q) \vee (\sim p \wedge q) \\ &\equiv (p \vee q \vee \sim p) \wedge (p \vee q \vee q) \\ &\equiv (q \vee t) \wedge (p \vee q) \\ &\equiv t \wedge (p \vee q) \equiv p \vee q \end{aligned}$$

50. $\sim(\sim s \vee (\sim r \wedge s)) \equiv \sim(\sim s) \wedge \sim(\sim r \wedge s)$

$$\begin{aligned} &\equiv s \wedge (\sim(\sim r) \vee \sim s) \equiv s \wedge (r \vee \sim s) \\ &\equiv (s \wedge r) \vee (s \wedge \sim s) \\ &\equiv (s \wedge r) \vee F \quad [\because s \wedge \sim s \text{ is false}] \\ &\equiv s \wedge r \end{aligned}$$

51. Given, $\frac{x_1 + x_2 + x_3 + \dots + x_{16}}{16} = 16$

$$\Rightarrow \sum_{i=1}^{16} x_i = 16 \times 16$$

Sum of new observations

$$= \sum_{i=1}^{18} y_i = (16 \times 16 - 16) + (3 + 4 + 5) = 252$$

Number of observations = 18

$$\therefore \text{New mean} = \frac{\sum_{i=1}^{18} y_i}{18} = \frac{252}{18} = 14$$

52. Given, $n(A) = 4, n(B) = 2 \Rightarrow n(A \times B) = 8$

Total number of subsets of set $(A \times B) = 2^8$

Number of subsets of set $A \times B$ having no element (i.e. ϕ) = 1.

Number of subsets of set $A \times B$ having one element = 8C_1

Number of subsets of set $A \times B$ having two elements = 8C_2

\therefore Number of subsets having atleast three elements

$$\begin{aligned} &= 2^8 - (1 + {}^8C_1 + {}^8C_2) = 2^8 - 1 - 8 - 28 \\ &= 2^8 - 37 = 256 - 37 = 219 \end{aligned}$$

53. According to the given information, the figure should be as follows:

Let the height of tower = h

In $\triangle EDA$, $\tan 30^\circ = \frac{ED}{AD}$

$$\frac{1}{\sqrt{3}} = \frac{ED}{AD} = \frac{h}{AD}$$

$$\Rightarrow AD = h\sqrt{3}$$

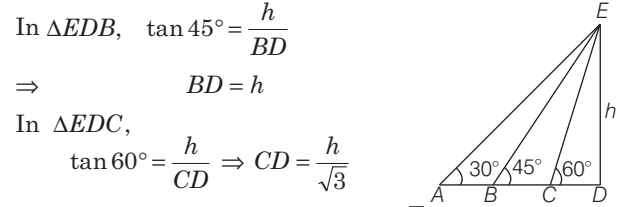

In $\triangle EDB$, $\tan 45^\circ = \frac{h}{BD}$

$$\Rightarrow BD = h$$

In $\triangle EDC$,

$$\tan 60^\circ = \frac{h}{CD} \Rightarrow CD = \frac{h}{\sqrt{3}}$$

Now, $\frac{AB}{BC} = \frac{AD - BD}{BD - CD} \Rightarrow \frac{AB}{BC} = \frac{h\sqrt{3} - h}{h - \frac{h}{\sqrt{3}}}$

$$\Rightarrow \frac{AB}{BC} = \frac{h(\sqrt{3} - 1)}{\frac{h(\sqrt{3} - 1)}{\sqrt{3}}} \Rightarrow \frac{AB}{BC} = \frac{\sqrt{3} - 1}{(\sqrt{3} - 1)} \times \sqrt{3}$$

$$\Rightarrow \frac{AB}{BC} = \frac{\sqrt{3}}{1} \Rightarrow AB:BC = \sqrt{3}:1$$

54.

p	q	$\sim p$	$\sim q$	$p \leftrightarrow q$	$p \leftrightarrow \sim q$	$\sim p \leftrightarrow q$	$\sim(p \leftrightarrow \sim q)$
T	F	F	T	F	T	T	F
F	T	T	F	F	T	T	F
T	T	F	F	T	F	F	T
F	F	T	T	T	F	F	T

Hence, $\sim(p \leftrightarrow \sim q)$ is equivalent to $(p \leftrightarrow q)$.

55. In $\triangle OA_1B_1$,

$$\tan 45^\circ = \frac{A_1B_1}{OB_1} \Rightarrow \frac{20}{OB_1} = 1 \Rightarrow OB_1 = 20$$

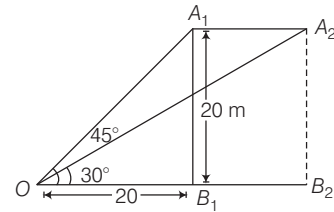

In $\triangle OA_2B_2$, $\tan 30^\circ = \frac{20}{OB_2} \Rightarrow OB_2 = 20\sqrt{3}$

$$\Rightarrow B_1B_2 + OB_1 = 20\sqrt{3} \Rightarrow B_1B_2 = 20\sqrt{3} - 20$$

$$\Rightarrow B_1B_2 = 20(\sqrt{3} - 1) \text{ m}$$

Now, Speed = $\frac{\text{Distance}}{\text{Time}} = 20(\sqrt{3} - 1) \text{ m/s}$

56. We have, $X = \{4^n - 3n - 1 : n \in N\}$

$$X = \{0, 9, 54, 243, \dots\} \quad [\text{put } n = 1, 2, 3, \dots]$$

$$Y = \{9, n - 1 : n \in N\}$$

$$Y = \{0, 9, 18, 27, \dots\} \quad [\text{put } n = 1, 2, 3, \dots]$$

It is clear that, $X \subset Y$

$$\therefore X \cup Y = Y$$

57. Here, $\bar{X} = \frac{\sum X_i}{n} = \frac{2 + 4 + 6 + 8 + \dots + 100}{50} = \frac{50 \times 51}{50} = 51$

$$[\because \sum 2n = n(n + 1), \text{ here } n = 50]$$

Variance, $\sigma^2 = \frac{1}{n} \sum X_i^2 - (\bar{X})^2$

$$= \frac{1}{50} (2^2 + 4^2 + \dots + 100^2) - (51)^2 = 833$$

624 Miscellaneous

58. If initially all marks were x_i , then

$$\sigma_1^2 = \frac{\sum (x_i - \bar{x})^2}{N}$$

Now, each is increased by 10.

$$\therefore \sigma_2^2 = \frac{\sum [(x_i + 10) - (\bar{x} + 10)]^2}{N} = \sigma_1^2$$

So, variance will not change whereas mean, median and mode will increase by 10.

59. Given, $n(A) = 2, n(B) = 4$

$$\therefore n(A \times B) = 8$$

The number of subsets of $A \times B$ having 3 or more elements = ${}^8C_3 + {}^8C_4 + \dots + {}^8C_8$

$$= ({}^8C_0 + {}^8C_1 + {}^8C_2 + {}^8C_3 + \dots + {}^8C_8) - ({}^8C_0 + {}^8C_1 + {}^8C_2)$$

$$\therefore 2^n = {}^n C_0 + {}^n C_1 + \dots + {}^n C_n = 2^8 - {}^8 C_0 - {}^8 C_1 - {}^8 C_2 \\ = 256 - 1 - 8 - 28 = 219$$

60. Let $x = \log_2 7 \Rightarrow 2^x = 7$

which is only possible for irrational number.

61. Given, $\log_{0.3}(x-1) < \log_{0.9}(x-1)$

Here, $x-1 > 0$ and $\log_{(0.3)}(x-1) < \log_{(0.3)^2}(x-1)$

$$\Rightarrow x > 1 \text{ and } \log_{0.3}(x-1) < \frac{1}{2} \log_{0.3}(x-1)$$

$$\Rightarrow x > 1 \text{ and } \log_{(0.3)}(x-1) < 0 \Rightarrow x > 1 \text{ and } x > 2$$

$$\therefore x \in (2, \infty)$$

62. Given, $x_1 < x_2 < x_3 < \dots < x_{201}$

$$\therefore \text{Median of the given observation} = \left(\frac{201+1}{2}\right)\text{th item} = x_{101}$$

Now, deviations will be minimum, if we taken from the median.

\therefore Mean deviation will be minimum, if $k = x_{101}$.

63. Here, $2 \log_{10} x - \log_x(10)^{-2} = 2 \log_{10} x + 2 \log_x 10$

$$= 2 \log_{10} x + 2 \frac{1}{\log_{10} x} = 2 \left(\log_{10} x + \frac{1}{\log_{10} x} \right) \quad \dots(i)$$

Using AM \geq GM, we get

$$\frac{\log_{10} x + \frac{1}{\log_{10} x}}{2} \geq \left(\log_{10} x \cdot \frac{1}{\log_{10} x} \right)^{1/2}$$

$$\Rightarrow \log_{10} x + \frac{1}{\log_{10} x} \geq 2 \quad \dots(ii)$$

$$\text{or } 2 \log_{10} x - \log_x(0.01) \geq 4$$

Hence, least value is 4.

64. (a) $\because e^x \in (1, e)$ in $(0, 1)$ and $\int_0^x f(t) \sin t \, dt \in (0, 1)$ in $(0, 1)$

$$\therefore e^x - \int_0^x f(t) \sin t \, dt \text{ cannot be zero.}$$

So, option (a) is incorrect.

(b) $f(x) + \int_0^{\frac{\pi}{2}} f(t) \sin t \, dt$ always positive

\therefore Option (b) is incorrect.

(c) Let $h(x) = x - \int_0^{\frac{\pi}{2}-x} f(t) \cos t \, dt$,

$$h(0) = - \int_0^{\frac{\pi}{2}} f(t) \cos t \, dt < 0 \Rightarrow h(1) = 1 - \int_0^{\frac{\pi}{2}-1} f(t) \cos t \, dt > 0$$

\therefore Option (c) is correct.

(d) Let $g(x) = x^9 - f(x) \Rightarrow g(0) = -f(0) < 0$

$$g(1) = 1 - f(1) > 0$$

\therefore Option (d) is correct.

65. $3^x = 4^{x-1}$

Taking \log_3 on both sides, we get

$$\Rightarrow x \log_3 3 = (x-1) \log_3 4 \Rightarrow x = 2 \log_3 2 \cdot x - \log_3 4$$

$$\Rightarrow x(1 - 2 \log_3 2) = -\log_3 4 \Rightarrow x = \frac{2 \log_3 2}{2 \log_3 2 - 1}$$

$$\Rightarrow x = \frac{1}{1 - \frac{1}{2 \log_3 2}} = \frac{1}{1 - \frac{1}{\log_3 4}} = \frac{1}{1 - \log_4 3} = \frac{2}{2 - \log_2 3}$$

$$\Rightarrow \frac{1}{1 - \frac{1}{2} \log_2 3} = \frac{1}{1 - \log_4 3}$$

66. Given sample space $S = \{1, 2, 3, 4, 5, 6\}$ and let there are i elements in set A and j elements in set B .

Now, according to information $1 \leq j < i \leq 6$. So, total number of ways of choosing sets A and

$$B = \sum_{1 \leq j < i \leq 6} {}^6 C_i {}^6 C_j$$

$$= \frac{\left(\sum_{r=1}^6 {}^6 C_r \right)^2 - \sum_{r=1}^6 ({}^6 C_r)^2}{2} = \frac{(2^6 - 1)^2 - ({}^1 C_6 - 1)}{2}$$

$$= \frac{(63)^2 - \frac{12!}{6!6!} + 1}{2} = \frac{3969 - 924 + 1}{2} = \frac{3046}{2} = 1523$$

67. $((\log_2 9)^2)^{\frac{1}{\log_2(\log_2 9)}} \times (\sqrt{7})^{\frac{1}{\log_4 7}}$
 $= (\log_2 9)^{2 \log_2(\log_2 9)} \times 7^{\frac{1}{2} \cdot \log_7 4}$ $\left[\because \frac{1}{\log_a b} = \log_b a \right]$
 $= (\log_2 9)^{\log(\log_2 9)^2} \times 7^{\log_7 2}$ $\left[\because {}_a \log_a b = b \right]$
 $= 2^2 \times 2 = 8$

68. Here $X = \{1, 6, 11, \dots, 10086\}$ $[\because a_n = a + (n-1)d]$

and $Y = \{9, 16, 23, \dots, 14128\}$

$$X \cap Y = \{16, 51, 86, \dots\}$$

t_n of $X \cap Y$ is less than or equal to 10086

$$\therefore t_n = 16 + (n-1)35 \leq 10086 \Rightarrow n \leq 288.7 \Rightarrow n = 288$$

$$\therefore n(X \cap Y) = n(X) + n(Y) - n(X \cup Y)$$

$$\therefore n(X \cap Y) = 2018 + 2018 - 288 = 3748$$

69. Given, X has exactly 5 elements and Y has exactly 7 elements.

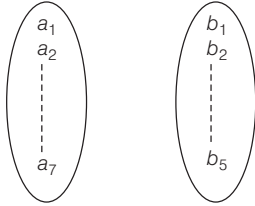

$\therefore n(X) = 5$ and $n(Y) = 7$
 Now, number of one-one functions from X to Y is
 $\alpha = {}^7P_5 = {}^7C_5 \times 5!$
 Number of onto functions from Y to X is β
 $1, 1, 1, 1, 3$ or $1, 1, 1, 2, 2$
 $\therefore \beta = \frac{7!}{3!4!} \times 5! + \frac{7!}{(2!)^3 3!} \times 5!$
 $= ({}^7C_3 + 3 {}^7C_3) 5! = 4 \times {}^7C_3 \times 5!$
 $\therefore \frac{\beta - \alpha}{5!} = \frac{(4 \times {}^7C_3 - {}^7C_5) 5!}{5!}$
 $= 4 \times 35 - 21 = 140 - 21 = 119$

70. Statement I $(p \wedge \sim q) \wedge (\sim p \wedge q)$
 $\equiv p \wedge \sim q \wedge \sim p \wedge q$
 $\equiv p \wedge \sim p \wedge \sim q \wedge q \equiv f \wedge f \equiv f$

Hence, it is a fallacy statement.

So, Statement I is true.

- Statement II $(p \rightarrow q) \leftrightarrow (\sim q \rightarrow \sim p)$
 $\equiv (p \rightarrow q) \leftrightarrow (p \rightarrow q)$

which is always true, so Statement II is true.

Alternate Solution

- Statement I $(p \wedge \sim q) \wedge (\sim p \wedge q)$

p	q	$\sim p$	$\sim q$	$p \wedge \sim q$	$\sim p \wedge q$	$(p \wedge \sim q) \wedge (\sim p \wedge q)$
T	T	F	F	F	F	F
T	F	F	T	T	F	F
F	T	T	F	F	T	F
F	F	T	T	F	F	F

Hence, it is a fallacy.

- Statement II $(p \rightarrow q) \leftrightarrow (\sim q \rightarrow \sim p)$
 $\sim q \rightarrow \sim p$ is contrapositive of $p \rightarrow q$. Hence,
 $(p \rightarrow q) \leftrightarrow (p \rightarrow q)$ will be a tautology.

71. It is given that, the centres of circles C_1, C_2 and C_3 are co-linear,

$\therefore \begin{vmatrix} 0 & 0 & 1 \\ 3 & 4 & 1 \\ h & k & 1 \end{vmatrix} = 0 \Rightarrow 4h = 3k$... (i)

and MN is the length of diameter of circle C_3 , so

$MN = 3 + \sqrt{(3-0)^2 + (4-0)^2} + 4 = 3 + 5 + 4 = 12$

So, radius of circle $C_3, r = 6$... (ii)

Since, the circle C_3 touches C_1 at M and C_2 at N , so

$|C_1 C_3| = |r - 3| \Rightarrow \sqrt{h^2 + k^2} = 3 \Rightarrow h^2 + k^2 = 9$... (iii)

From Eqs. (i) and (iii), we get

$h^2 + \frac{16h^2}{9} = 9 \Rightarrow 25h^2 = 81$

$\Rightarrow h = +\frac{9}{5}$ and $k = +\frac{12}{5}$

So, $2h + k = \frac{18}{5} + \frac{12}{5} = 6$

Now, equation common chord XY of circles C_1 and C_2 is
 $C_1 - C_2 = 0 \Rightarrow 6x + 8y = 18 \Rightarrow 3x + 4y = 9$... (iv)

Now,

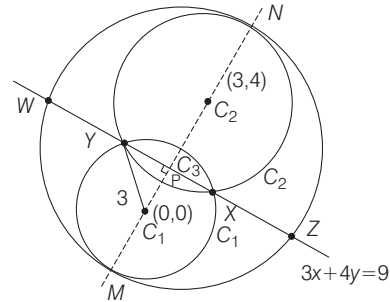

$C_1 P = \frac{9}{5}$

Now, $PY^2 = GY^2 - GP^2 = 9 - \frac{81}{25} = \frac{144}{25} \Rightarrow PY = \frac{12}{5}$

$\therefore XY = 2PY = 2 \times \frac{12}{5} = \frac{24}{5}$

Now, $C_3 P = \frac{\left| 3\left(\frac{9}{5}\right) + 4\left(\frac{12}{5}\right) - 9 \right|}{5} = \frac{6}{5}$

So, $PW^2 = C_3 W^2 - C_3 P^2 = 36 - \frac{36}{25} = \frac{864}{25}$

$\Rightarrow PW = \frac{12\sqrt{6}}{5} \Rightarrow ZW = 2PW = \frac{24\sqrt{6}}{5}$ $\{\because C_3 W = r = 6\}$

$\therefore \frac{\text{length of } ZW}{\text{length of } XY} = \sqrt{6}$

Now, area of triangle $MZN = \frac{1}{2} (MN) (PZ)$

$= \frac{1}{2} \times (12) \left(\frac{1}{2} WZ\right)$ $\{\because MN = 12\}$

$= 3WZ = 3 \frac{24\sqrt{6}}{5} = \frac{72\sqrt{6}}{5}$

and area of triangle $ZMW = \frac{1}{2} (ZW) (MP)$

$= \frac{1}{2} \left(\frac{24\sqrt{6}}{5}\right) (MG + GP) = \frac{12\sqrt{6}}{5} \left(3 + \frac{9}{5}\right)$

$\left\{ \because MG = 3 \text{ and } GP = \frac{9}{5} \right\}$

$= \frac{12\sqrt{6}}{5} \left(\frac{24}{5}\right) = \frac{288\sqrt{6}}{25}$

$\therefore \frac{\text{Area of triangle } MZN}{\text{Area of triangle } ZMW} = \frac{\frac{72\sqrt{6}}{5}}{\frac{288\sqrt{6}}{25}} = \frac{5}{4}$

626 Miscellaneous

∴ Common tangent of circles C_1 and C_3 is $C_1 - C_3 = 0$
 $\Rightarrow (x^2 + y^2 - 9) - \left[\left(x - \frac{9}{5}\right)^2 + \left(y - \frac{12}{5}\right)^2 - 36 \right] = 0$
 $\Rightarrow \frac{18}{5}x + \frac{24}{5}y + 18 = 0 \Rightarrow 3x + 4y + 15 = 0 \quad \dots (v)$

∴ Tangent (v) is also touches the parabola $x^2 = 8\alpha y$,
 $\therefore -2\alpha \left(-\frac{3}{4}\right)^2 = -\frac{15}{4} \Rightarrow \alpha = \frac{10}{3}$

So combination (iv), (S) is only incorrect.
Hence, option (b) is correct.

72. ∴ $\frac{\text{length of } ZW}{\text{length of } XY} = \sqrt{6}$

So, combination (ii), Q is only correct.
Hence, option (c) is correct.

73. Either option (a) or (c) is correct. But $a = \sqrt{2}$ and $(-1, 1)$ satisfy $x^2 + y^2 = a^2$.
So, option (a) is correct.

74. Either option (b) or (c) is correct.

Satisfying the point $\left(\sqrt{3}, \frac{1}{2}\right)$ in (II), we get
 $a^2 = 4$.

∴ The conic is $x^2 + 4y^2 = 4$
Now, equation of tangent at $\left(\sqrt{3}, \frac{1}{2}\right)$ is $\sqrt{3}x + 2y = 4$, which is the given equation. So, option (b) is correct.

75. Either option (a), (b) or (c) is correct.

Satisfying the point (8, 16) in (III), we get
∴ The conic is $y^2 = 32x = 16(2x)4$
Now, equation of tangent at (8, 16) is $y \cdot 16 = 16(x + 8)$
 $\Rightarrow y = x + 8$, which is the given in equation.
So, option (a) is correct.

76. $A \rightarrow P, Q; B \rightarrow P, Q; C \rightarrow P, Q, S, T; D \rightarrow Q, T$

A. Projection of $(\alpha\hat{i} + \beta\hat{j})$ on $(\sqrt{3}\hat{i} + \hat{j}) = \sqrt{3}$
 $\Rightarrow \frac{|\sqrt{3}\alpha + \beta|}{2} = \sqrt{3} \Rightarrow \sqrt{3}\alpha + \beta = \pm 2\sqrt{3} \quad \dots(i)$
and $\alpha - \sqrt{3}\beta = 2 \quad \dots(ii)$

On solving Eqs. (i) and (ii), we get
 $\alpha = 2, -1 \Rightarrow |\alpha| = 2, 1$

B. Since, if any function is differentiable, then it is continuous for all x .
By continuity at $x = 1$,

$-3a - 2 = b + a^2 \quad \dots(i)$

By differentiability, $f'(x) = \begin{cases} -6ax, & x < 1 \\ b, & x > 1 \end{cases}$

∴ $-6a = b \quad \dots(ii)$

From Eqs. (i) and (ii), we get

$-3a - 2 = -6a + a^2$

$\Rightarrow a^2 - 3a + 2 = 0 \Rightarrow a = 1, 2$

C. $(3 - 3\omega + 2\omega^2)^{4n+3} + (2 + 3\omega - 3\omega^2)^{4n+3}$

$+ (-3 + 2\omega + 3\omega^2)^{4n+3} = 0$
 $\Rightarrow \{(-3 + 2\omega + 3\omega^2)\omega\}^{4n+3} + \{-3 + 2\omega + 3\omega^2\omega^2\}^{4n+3} = 0$
 $\Rightarrow (-3 + 2\omega + 3\omega^2)^{4n+3} \{\omega^{4n+3} + (\omega^2)^{4n+3} + 1\} = 0$
 $\Rightarrow \omega^n + \omega^{2n} + 1 = 0$

which is true only when n is not a multiple of 3.
∴ $n = 1, 2, 4, 5$

D. Here, $\frac{2ab}{a+b} = 4$ and $2(5-a) = b-5$

$\Rightarrow b = 15 - 2a \quad \dots(i)$

Now, $2ab = 4(a+b)$

$\Rightarrow 2a(15-2a) = 4(a+15-2a)$

$\Rightarrow 15a - 2a^2 = 30 - 2a$

$\Rightarrow 2a^2 - 17a + 30 = 0 \Rightarrow a = 5/2, 6$

Hence, $|q - 2a| = |10 - 2a| = 5$ or 2

77. $A \rightarrow P, R, S; B \rightarrow P; C \rightarrow P, Q; D \rightarrow S, T$

A. Since, $2(a^2 - b^2) = c^2$

∴ $2(\sin^2 x - \sin^2 y) = \sin^2 z$ [using sine law]

$\Rightarrow 2 \sin(x-y) \cdot \sin(x+y) = \sin^2 z$

$\Rightarrow 2 \sin(x-y) \cdot \sin z = \sin^2 z$ [$\because x + y + z = \pi$]

$\Rightarrow \frac{\sin(x-y)}{\sin z} = \frac{1}{2} = \lambda$

Also, $\cos(n\pi\lambda) = 0 \Rightarrow \cos\left(\frac{n\pi}{2}\right) = 0 \Rightarrow n = 1, 3, 5$

B. $1 + \cos 2X - 2 \cos 2Y = 2 \sin X \cdot \sin Y$

$\Rightarrow 1 + 1 - 2 \sin^2 X - 2(1 - 2 \sin^2 Y) = 2 \sin X \cdot \sin Y$

$\Rightarrow -2a^2 + 4b^2 = 2ab$

$\Rightarrow a^2 + ab - 2b^2 = 0 \Rightarrow \left(\frac{a}{b}\right)^2 + \left(\frac{a}{b}\right) - 2 = 0$

$\Rightarrow \left(\frac{a}{b} + 2\right)\left(\frac{a}{b} - 1\right) = 0 \Rightarrow \frac{a}{b} = 1, -2$

C. $\mathbf{OX} = \sqrt{3}\hat{i} + \hat{j}, \mathbf{OY} = \hat{i} + \sqrt{3}\hat{j}, \mathbf{OZ} = \beta\hat{i} + (1-\beta)\hat{j}$

Angle bisector of \mathbf{OX} and \mathbf{OY} is along the line $y = x$ and its distance from $(\beta, 1-\beta)$ is

$\frac{|\beta - (1-\beta)|}{\sqrt{2}} = \frac{3}{\sqrt{2}} \Rightarrow 2\beta - 1 = \pm 3$

∴ $\beta = 2, -1$ or $|\beta| = 1, 2$

D. Area bounded by $x = 0, x = 2, y^2 = 4x$

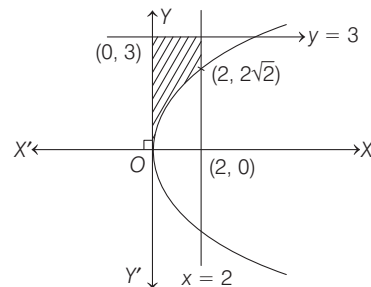

When $\alpha = 0$, then

Area bounded, $F(\alpha) = 2 \times 3 - \int_0^2 \sqrt{4x} dx$

$$= 6 - 2 \left[\frac{x^{3/2}}{3/2} \right]_0^2 = 6 - \frac{4}{3} \cdot (2^{3/2} - 0) = 6 - \frac{8}{3} \sqrt{2}$$

$$\therefore F(\alpha) + \frac{8\sqrt{2}}{3} = 6 \quad \dots(i)$$

When $\alpha = 1$, then

$$y = |x-1| + |x-2| + x = \begin{cases} 3x-3, & x \geq 2 \\ x+1, & 1 < x < 2 \\ 3-x, & x \leq 1 \end{cases}$$

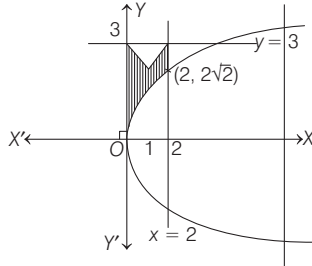

\therefore Area bounded,

$$F(\alpha) = (6-1) - \int_0^2 2\sqrt{x} dx \Rightarrow F(\alpha) = 5 - \frac{8}{3} \sqrt{2}$$

$$\therefore F(\alpha) + \frac{8}{3} \sqrt{2} = 5 \quad \dots(ii)$$

Hence, values of $F(\alpha) + \frac{8}{3} \sqrt{2}$ are 5 or 6. [from Eqs. (i) and (ii)]

78. (P) $y = \cos(3 \cos^{-1} x) \Rightarrow y' = \frac{3 \sin(3 \cos^{-1} x)}{\sqrt{1-x^2}}$

$$\sqrt{1-x^2} y' = 3 \sin(3 \cos^{-1} x)$$

$$\Rightarrow \frac{-x}{\sqrt{1-x^2}} y' + \sqrt{1-x^2} y'' = 3 \cos(3 \cos^{-1} x) \cdot \frac{-3}{\sqrt{1-x^2}}$$

$$\Rightarrow -xy' + (1-x^2) y'' = -9y \Rightarrow \frac{1}{y} [(x^2-1) y'' + xy'] = 9$$

(Q) PLAN

(i) Angle subtended by a side of n sided regular polygon at the centre = $\frac{2\pi}{n}$.

(ii) $|\mathbf{a} \times \mathbf{b}| = |\mathbf{a}| |\mathbf{b}| \sin \theta$

(iii) $|\mathbf{a} \cdot \mathbf{b}| = |\mathbf{a}| |\mathbf{b}| \cos \theta$

(iv) $\tan \theta = \tan \alpha \Rightarrow \theta = n\pi + \alpha, n \in Z$

Consider a polygon(S) of n sides with centre at origin

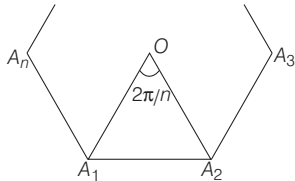

Let $|\mathbf{OA}_1| = |\mathbf{OA}_2| = \dots = |\mathbf{OA}_n| = r$ [say]

$$|\mathbf{a}_k \times \mathbf{a}_{k+1}| = r^2 \sin \frac{2\pi}{n} \Rightarrow |\mathbf{a}_k \cdot \mathbf{a}_{k+1}| = r^2 \cos \frac{2\pi}{n}$$

$$\Rightarrow \left| \sum_{k=1}^{n-1} \mathbf{a}_k \times \mathbf{a}_{k+1} \right| = \left| \sum_{k=1}^{n-1} \mathbf{a}_k \cdot \mathbf{a}_{k+1} \right|$$

$$\Rightarrow r^2(n-1) \sin \frac{2\pi}{n} = r^2(n-1) \cos \frac{2\pi}{n}$$

$$\Rightarrow \tan \frac{2\pi}{n} = 1 \Rightarrow \tan \frac{2\pi}{n} = \tan \frac{\pi}{4}$$

$$\Rightarrow \frac{2\pi}{n} = t\pi + \frac{\pi}{4}, t \in Z$$

$$\Rightarrow \frac{2}{n} = \frac{4t+1}{4} \Rightarrow n = \frac{8}{4t+1}, t \in Z$$

\therefore The minimum value of $n = 8$

(R) PLAN

Equation of normal at the point

$(a \cos \theta, b \sin \theta)$ of ellipse $\frac{x^2}{a^2} + \frac{y^2}{b^2} = 1$ is given by

$$ax \sec \theta - by \operatorname{cosec} \theta = a^2 - b^2$$

Equation of normal is

$$\sqrt{6} x \sec \theta - \sqrt{3} y \operatorname{cosec} \theta = 3$$

Its slope is $\frac{\sqrt{6} \sec \theta}{\sqrt{3} \operatorname{cosec} \theta} = 1$

\therefore Slope of normal = Slope of line perpendicular to

$$x + y = 8 \Rightarrow \tan \theta = \frac{1}{\sqrt{2}}$$

So, normal is $\sqrt{6} x \frac{\sqrt{3}}{\sqrt{2}} - \sqrt{3} \times \sqrt{3} y = 3$

$$3x - 3y = 3 \Rightarrow x - y = 1$$

As it passes through $(h, 1)$.

$$\therefore h - 1 = 1 \Rightarrow h = 2$$

(S) Plan $\tan^{-1} x + \tan^{-1} y = \tan^{-1} \left(\frac{x+y}{1-xy} \right)$

Given equation

$$\tan^{-1} \left(\frac{1}{2x+1} \right) + \tan^{-1} \left(\frac{1}{4x+1} \right) = \tan^{-1} \left(\frac{2}{x^2} \right)$$

$$\Rightarrow \tan^{-1} \left[\frac{\frac{1}{2x+1} + \frac{1}{4x+1}}{1 - \frac{1}{(2x+1)(4x+1)}} \right] = \tan^{-1} \left(\frac{2}{x^2} \right)$$

$$\Rightarrow \tan^{-1} \left[\frac{6x+2}{(2x+1)(4x+1)-1} \right] = \tan^{-1} \left(\frac{2}{x^2} \right)$$

$$\Rightarrow \frac{3x+1}{4x^2+3x} = \frac{2}{x^2} \Rightarrow 3x^3 + x^2 = 8x^2 + 6x$$

$$\Rightarrow x(3x^2 - 7x - 6) = 0$$

$$\Rightarrow x(x-3)(3x+2) = 0 \Rightarrow x = 0, \frac{-2}{3}, 3$$

So, only positive solution is $x = 3$.

(P) \rightarrow (iv); (Q) \rightarrow (iii); (R) \rightarrow (ii); (S) \rightarrow (i)

79. (A) Given, $|z| = 1$

$$\Rightarrow z \cdot \bar{z} = 1 \Rightarrow \frac{2iz}{1-z^2} = \frac{2iz}{z \cdot \bar{z} - z^2} = \frac{2i}{\bar{z} - z}$$

Let $z = x + iy$

628 Miscellaneous

$$\therefore z - \bar{z} = 2iy = \frac{2i}{-2iy} = -\frac{1}{y} \quad \dots(i)$$

where $y = \sqrt{1-x^2} \Rightarrow -1 \leq y \leq 1$
 $\Rightarrow -1 \leq y$ and $y \leq 1 \Rightarrow -1 \geq \frac{1}{y}$ and $\frac{1}{y} \geq 1$

$$\Rightarrow \operatorname{Re} \left(\frac{2iz}{1-z^2} \right) \in (-\infty, -1] \cup [1, \infty)$$

(B) $f(x) = \sin^{-1} \left(\frac{8(3^{x-2})}{1-3^{2(x-1)}} \right)$, for domain
 $-1 \leq \frac{8(3^{x-2})}{1-3^{2(x-1)}} \leq 1 \Rightarrow -1 \leq \frac{9 \cdot (3^{x-2}) - (3^{x-2})}{1-3^{2(x-1)}} \leq 1$

$$\therefore -1 \leq \frac{3^x - 3^{x-2}}{1-3^x \cdot 3^{x-2}} \leq 1 \Rightarrow \frac{3^x - 3^{x-2}}{1-3^x \cdot 3^{x-2}} \geq -1$$

$$\Rightarrow \frac{(3^x + 1)(3^{x-2} - 1)}{(3^{x-1} + 1)(3^{x-1} - 1)} \geq 0$$

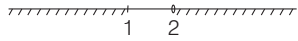

$$\Rightarrow x \in (-\infty, 1] \cup (2, \infty) \text{ and } \frac{3^x - 3^{x-2}}{1-3^x \cdot 3^{x-2}} \leq 1$$

$$\Rightarrow \frac{(3^{x-2} - 1)(3^x + 1)}{(3^{x-1} + 1)(3^{x-1} - 1)} \geq 0$$

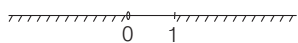

and $x \in (-\infty, 0) \cup [1, \infty) \Rightarrow x \in (-\infty, 0] \cup [2, \infty)$

(C) $f(\theta) = \begin{vmatrix} 1 & \tan \theta & 1 \\ -\tan \theta & 1 & \tan \theta \\ -1 & -\tan \theta & 1 \end{vmatrix}$

Applying $R_1 \rightarrow R_1 + R_3$

$$f(\theta) = \begin{vmatrix} 0 & 0 & 2 \\ -\tan \theta & 1 & \tan \theta \\ -1 & -\tan \theta & 1 \end{vmatrix} = 2(\tan^2 \theta + 1) = 2 \sec^2 \theta \geq 2$$

$$f(\theta) \in [2, \infty)$$

(D) $f(x) = x^{3/2}(3x-10); x \geq 0$

$$f'(x) = x^{3/2} \cdot 3 + \frac{3}{2} \cdot x^{1/2}(3x-10) = 3x^{1/2} \left\{ x + \frac{1}{2}(3x-10) \right\}$$

$$= \frac{3}{2} x^{1/2} \{2x + 3x - 10\}$$

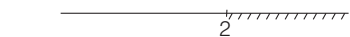

$$= \frac{15}{2} x^{1/2}(x-2) \Rightarrow x \geq 2$$

80. (A) $|\vec{a}| = \sqrt{1+3} = 2 \Rightarrow |\vec{b}| = \sqrt{1+3} = 2, |\vec{c}| = \sqrt{12} = 2\sqrt{3}$

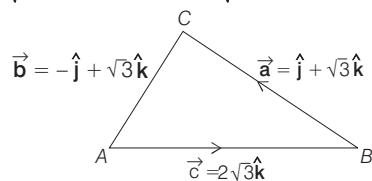

Using cosine law,

$$\cos C = \frac{|\vec{a}|^2 + |\vec{b}|^2 - |\vec{c}|^2}{2|\vec{a}||\vec{b}|} = \frac{4+4-12}{2 \times 2 \times 2} = \frac{-4}{8} = \frac{-1}{2}$$

$$\Rightarrow \angle C = 120^\circ = \frac{2\pi}{3}$$

(B) $\int_a^b f(x) dx - 3 \left(\frac{x^2}{2} \right)_a^b = (a^2 - b^2)$

$$\Rightarrow \int_a^b f(x) dx - \frac{3}{2}(b^2 - a^2) = (a^2 - b^2)$$

$$\Rightarrow \int_a^b f(x) dx = (a^2 - b^2) + \frac{3}{2}(b^2 - a^2) = \frac{b^2 - a^2}{2}$$

$$\Rightarrow \int_a^b f(x) dx = \frac{b^2 - a^2}{2} \Rightarrow f(x) = x \Rightarrow f\left(\frac{\pi}{6}\right) = \frac{\pi}{6}$$

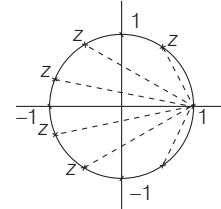

(C) $\frac{\pi^2}{\log_e 3} \int_{\pi/6}^{5\pi/6} \sec(\pi x) dx$

$$\Rightarrow \frac{\pi^2}{\log_e 3} \left\{ \log_e |\sec \pi x + \tan \pi x| \right\}_{\pi/6}^{5\pi/6}$$

$$\Rightarrow \frac{\pi}{\log_e 3} \left\{ \log_e \left| \sec \frac{5\pi}{6} + \tan \frac{5\pi}{6} \right| - \log_e \left| \sec \frac{7\pi}{6} + \tan \frac{7\pi}{6} \right| \right\}$$

$$\Rightarrow \frac{\pi}{\log_e 3} \left\{ \log_e |\sqrt{3}| - \log_e \left| \frac{1}{\sqrt{3}} \right| \right\} \Rightarrow \frac{\pi}{\log_e 3} \{ \log_e 3 \} = \pi$$

(D) $\left| \arg \frac{1}{(1-z)} \right|$ for $|z|=1 \Rightarrow |\arg(1-z)^{-1}|$

$$\Rightarrow |-\arg(1-z)|$$

$$\Rightarrow |\arg(1-z)|$$

From figure, $\arg(z-1)$ is maximum $\Rightarrow \pi$

81. (A) Equation of the line passing through origin is

$$\frac{x}{a} = \frac{y}{b} = \frac{z}{c} \Rightarrow \begin{vmatrix} 2 & 1 & -1 \\ 1 & -2 & 1 \\ a & b & c \end{vmatrix} = 0$$

$$\Rightarrow a(-1) - b(3) + c(-5) = 0 \Rightarrow -a - 3b - 5c = 0$$

$$\Rightarrow a + 3b + 5c = 0 \quad \dots(i)$$

Also, $\begin{vmatrix} 8 & -3 & 1 \\ 3 & 2 & 1 \\ a & b & c \end{vmatrix} = 0$

$$\therefore a(-2) - b\left(\frac{2}{3}\right) + c\left(\frac{10}{3}\right) = 0 \Rightarrow 2a + \frac{2b}{3} - \frac{10c}{3} = 0$$

$$\Rightarrow 3a + b - 5c = 0 \quad \dots(ii)$$

From Eqs. (i) and (ii), $\frac{a}{-20} = \frac{b}{20} = \frac{c}{-8} \Rightarrow \frac{a}{5} = \frac{b}{-5} = \frac{c}{4}$

Equation of line is

$$\frac{x}{5} = \frac{y}{-5} = \frac{z}{4} = \lambda \quad \text{[say]} \quad \dots(iii)$$

Also $\frac{x-2}{1} = \frac{y-1}{-2} = \frac{z+1}{1} = k_1 \quad \text{[say]} \dots(iv)$

Now, $\frac{x-\frac{8}{3}}{2} = \frac{y+3}{-1} = \frac{z-1}{1} = k_2 \quad \text{[say]} \dots(v)$

Point on Eq. (iii) is $(5\lambda, -5\lambda, +4\lambda)$.

Point on Eq. (iv) is $(2+k_1, 1-2k_1, -1+k_1)$.

Point on Eq. (v) is $(\frac{8}{3}+2k_2, -3-k_2, 1+k_2)$.

On solving, $2+k_1+1-2k_1=0 \Rightarrow -k_1+3=0$

$\Rightarrow k_1=3 \Rightarrow P \equiv (5, -5, 2)$

Again, for Q, $\frac{8}{3}+2k_2-3-k_2=0$

$\Rightarrow k_2-\frac{1}{3}=0 \Rightarrow k_2=1/3 \Rightarrow Q \equiv (\frac{10}{3}, -\frac{10}{3}, \frac{4}{3})$

Now, $PQ = \sqrt{(\frac{5}{3})^2 + (\frac{5}{3})^2 + (\frac{2}{3})^2} = \frac{\sqrt{54}}{3}$

$\Rightarrow PQ^2 = d^2 = \frac{54}{9} = 6$

(B) $\tan^{-1}\left(\frac{x+3-x+3}{1+(x^2-9)}\right) = \tan^{-1}\left(\frac{3}{4}\right) \Rightarrow \frac{6}{x^2-8} = \frac{3}{4}$

$\Rightarrow 3x^2 = 48 \Rightarrow x = \pm 4$

(C) $(\vec{b} - \vec{a}) \cdot \left(\vec{b} + \frac{\vec{a} - \mu \vec{b}}{4}\right) = 0$

$\Rightarrow (\vec{b} - \vec{a}) \cdot (4\vec{b} + \vec{a} - \mu \vec{b}) = 0 \Rightarrow (4-\mu)\vec{b}^2 - \vec{a}^2 = 0 \quad \dots(i)$

Also, $2 \left| \vec{b} + \frac{\vec{a} - \mu \vec{b}}{4} \right| = |\vec{b} - \vec{a}|$

$\Rightarrow 2 \left| \frac{(4-\mu)\vec{b} + \vec{a}}{4} \right| = |\vec{b} - \vec{a}|$

$\Rightarrow \frac{(4-\mu)^2 \vec{b}^2 + \vec{a}^2}{4} = \vec{b}^2 + \vec{a}^2 \Rightarrow \frac{3\vec{a}^2}{4} = \frac{(4-\mu)^2 - 4}{4} \vec{b}^2$

$\Rightarrow 3\vec{a}^2 = \vec{b}^2 (4-\mu)^2 - 4\vec{b}^2 \quad \dots(ii)$

From Eqs. (i) and (ii), $3(4-\mu) = (4-\mu)^2 - 4$

$(4-\mu)^2 - 3(4-\mu) - 4 = 0 \Rightarrow \mu = 0, 5$

$\mu = 5$ is not admissible.

(D) $f(0) = 9, f(x) = \frac{\sin\left(\frac{9x}{2}\right)}{\sin\frac{x}{2}} = \left(3-4\sin^2\frac{x}{2}\right)\left(3-4\sin^2\frac{3x}{2}\right)$

$= 9 - 12\sin^2\frac{x}{2} - 12\sin^2\frac{3x}{2} + 16\sin^2\frac{x}{2} \cdot \sin^2\frac{3x}{2}$

$= 9 - 6(1 - \cos x) - 6(1 - \cos 3x) + 4(1 - \cos x)(1 - \cos 3x)$
 $= 1 + 6\cos x + 6\cos 3x - 4\cos x - 4\cos 3x + 4\cos x \cos 3x$

Let $I = \frac{2}{\pi} \int_{-\pi}^{\pi} \frac{\sin\frac{9x}{2}}{-\pi \sin\frac{x}{2}} dx = \frac{4}{\pi} \int_0^{\pi} 1 + 2\cos x + 2\cos 3x + 2(\cos 4x + \cos x) dx = \frac{4}{\pi} \times \pi = 4$

82. (A) $2\sin^2\theta + \sin^2 2\theta = 2$

$\Rightarrow \sin^2 2\theta = 2\cos^2\theta \Rightarrow 4\sin^2\theta \cos^2\theta = 2\cos^2\theta$

$\Rightarrow \cos^2\theta = 0$ or $\sin^2\theta = \frac{1}{2}$

$\Rightarrow \cos\theta = 0$ or $\sin\theta = \pm \frac{1}{\sqrt{2}} \Rightarrow \theta = \pm \frac{\pi}{4}$ or $\frac{\pi}{2}$

(B) $f(x) = \left[\frac{6x}{\pi}\right] \cos\left[\frac{3x}{\pi}\right]$

Possible points of discontinuity of $\left[\frac{6x}{\pi}\right]$ are

$\frac{6x}{\pi} = n, n \in I \Rightarrow x = \frac{n\pi}{6} \Rightarrow x = \frac{\pi}{6}, \frac{\pi}{3}, \frac{\pi}{2}, \pi$

$\Rightarrow \lim_{x \rightarrow \frac{\pi}{6}^-} f(x) = 0 \cos 0 = 0 \Rightarrow \lim_{x \rightarrow \left(\frac{\pi}{6}\right)^+} f(x) = 1 \cos 0 = 1$

\therefore Discontinuous at $x = \pi/6$.

Similarly, discontinuous at $x = \frac{\pi}{3}, \frac{\pi}{2}, \pi$

(C) Here, $V = \left| \begin{vmatrix} 1 & 1 & 0 \\ 1 & 2 & 0 \\ 1 & 1 & \pi \end{vmatrix} \right| = \pi$ cu unit

(D) Given, $\vec{a} + \vec{b} + \sqrt{3}\vec{c} = \vec{0}$

$\Rightarrow \vec{a} + \vec{b} = -\sqrt{3}\vec{c} \Rightarrow |\vec{a} + \vec{b}|^2 = |\sqrt{3}\vec{c}|^2$

$\Rightarrow a^2 + b^2 + 2\vec{a} \cdot \vec{b} = 3c^2 \Rightarrow 2 + 2\cos\theta = 3$

$\Rightarrow \cos\theta = \frac{1}{2} \Rightarrow \theta = \frac{\pi}{3}$

83. (A) Let $f(x) = xe^{\sin x} - \cos x$

$f'(x) = e^{\sin x} + xe^{\sin x} \cos x + \sin x \geq 0$

For interval $x \in \left(0, \frac{\pi}{2}\right)$, f is strictly increasing.

$\therefore f(0) = -1$ and $f\left(\frac{\pi}{2}\right) = \frac{\pi}{2}e \Rightarrow$ One solution

(B) Since, $\begin{vmatrix} k & 4 & 1 \\ 4 & k & 2 \\ 2 & 2 & 1 \end{vmatrix} = 0$

$\Rightarrow k(k-4) - 4(0) + 1(8-2k) = 0$

$\Rightarrow k^2 - 6k + 8 = 0 \Rightarrow k = 2, 4$

(C) Let $y = |x-1| + |x-2| + |x+1| + |x+2|$

For solutions, $4k \geq 6 \Rightarrow k \geq \frac{3}{2}$

630 Miscellaneous

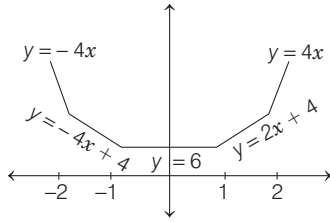

Integer values of k are 2, 3, 4, 5.

(D) Given, $\frac{dy}{dx} = y + 1 \Rightarrow \ln|(y+1)| = x + C$

$\Rightarrow \ln 2 = C \Rightarrow \ln|y+1| = x + \ln 2$

Put $x = \ln 2$

$\therefore \ln(y+1) = \ln 2 + \ln 2 = \ln 4$

$\Rightarrow y + 1 = 4 \Rightarrow y = 3$

84. (p) $\frac{1}{\sqrt{h^2 + k^2}} = 2 \Rightarrow h^2 + k^2 = \frac{1}{4}$

Hence, locus is a circle.

(q) $||z+2| - |z-2|| = 3$ and $2 - (-2) = 4 > 3$

Hence, locus is a hyperbola.

(r) Let $x = \sqrt{3} \left(\frac{1-t^2}{1+t^2} \right), y = \frac{2t}{1+t^2}$

Let $\tan \theta = t$

Then, $x = \sqrt{3} \cos 2\theta, y = \sin 2\theta \Rightarrow \frac{x^2}{3} + y^2 = 1$

Hence, locus is an ellipse.

(s) Eccentricity $e = 1 \Rightarrow$ Parabola

$1 < e < \infty \Rightarrow$ Hyperbola

(t) Let $z = x + iy$

Since, $\operatorname{Re}(z+1)^2 = |z|^2 + 1$

$\Rightarrow (x+1)^2 - y^2 = x^2 + y^2 + 1 \Rightarrow 2x = 2y^2 \Rightarrow x = y^2$

Hence, locus is parabola.

85. (A) Given, $(x-3)^2 \cdot y' + y = 0$

$\Rightarrow \frac{dy}{dx} = -\frac{y}{(x-3)^2} \Rightarrow \int \frac{dy}{y} = -\int \frac{dx}{(x-3)^2}$

$\Rightarrow \ln y = \frac{1}{(x-3)} + \ln C \Rightarrow y = Ce^{\frac{1}{x-3}}, C \neq 0$

\therefore Domain of y is $x \in \mathbb{R} - \{3\}$

Alternate Solution Given differential equation is homogeneous linear differential equation and has $x=3$ as a singular point, hence $x=3$ cannot be in domain of solution.

(B) Let $I = \int_1^5 (x-1)(x-2)(x-3)(x-4)(x-5) dx$

Let $x-3 = t \Rightarrow dx = dt$

$\therefore I = \int_{-2}^2 (t+2)(t+1)t(t-1)(t-2) dt$

Q Integrand is an odd function. $\Rightarrow I = 0$

Alternate Solution

Let $I = \int_1^5 (x-1)(x-2)(x-3)(x-4)(x-5) dx \dots(i)$

Using, $\int_a^b f(x) dx = \int_a^b f(a+b-x) dx$

$I = \int_1^5 (5-x)(4-x)(3-x)(2-x)(1-x) dx \dots(ii)$

On adding Eqs. (i) and (ii), we get, $2I = 0 \Rightarrow I = 0$

(C) Let $f(x) = \cos^2 x + \sin x$

$f'(x) = -2 \cos x \sin x + \cos x$
 $= \cos x(1 - 2 \sin x) = 0$ [say]

Sign scheme for first derivative

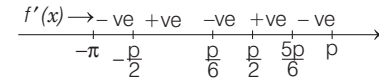

Points of local maxima are $\frac{\pi}{6}, \frac{5\pi}{6}$.

Alternate Solution $y = \cos^2 x + \sin x$

$y = \frac{5}{4} - \left(\sin x - \frac{1}{2} \right)^2$

For y to be maximum, $\left(\sin x - \frac{1}{2} \right)^2 = 0$

$\Rightarrow \sin x = \frac{1}{2} \Rightarrow x = n\pi + (-1)^n \frac{\pi}{6}, n \in \mathbb{I}$

(D) Let $y = \tan^{-1}(\sin x + \cos x)$

$\frac{dy}{dx} = \frac{\cos x - \sin x}{1 + (\sin x + \cos x)^2}$

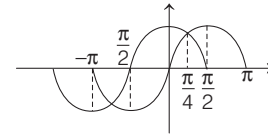

Clearly, by graph $\cos x > \sin x$ is true for option (s).

86. (A) Let $y = \frac{x^2 + 2x + 4}{x + 2}$

$\Rightarrow x^2 + (2-y)x + (4-2y) = 0$

$\Rightarrow (2-y)^2 - 4(4-2y) \geq 0 \quad [\because D \geq 0]$

$\Rightarrow y^2 + 4y - 12 \geq 0 \Rightarrow y \leq -6, y \geq 2$

\therefore Minimum value of y is 2.

(B) Since, $(A+B)(A-B) = (A-B)(A+B)$

$\Rightarrow A^2 - AB + BA - B^2 = A^2 + AB - BA - B^2$

$\Rightarrow AB = BA$ and $(AB)^t = (-1)^k AB$

$\Rightarrow B^t A^t = (-1)^k AB$

$\Rightarrow -B \cdot A = (-1)^k AB \quad [\because B^t = -B, A^t = A]$

$\Rightarrow B \cdot A = (-1)^{k+1} AB \Rightarrow (-1)^{k+1} = 1$

$\therefore k+1$ is even or k is odd.

(C) $1 < 2^{(-k+3^{-a})} < 2 \Rightarrow 0 < -k+3^{-a} < 1$

Given, $a = \log_3 \log_3 2$

$\Rightarrow 3^a = \log_3 2 \Rightarrow 3^{-a} = \log_2 3 \dots(i)$

$\therefore k < \log_2 3 < 2 \dots(ii)$

and $1 + k > \log_2 3 > 1 \Rightarrow k > 0 \dots(iii)$

From Eqs. (ii) and (iii),

$0 < k < 2 \Rightarrow k = 1$ [since, k is an integer]

(D) $\sin \theta = \cos \phi$
 $\Rightarrow \cos\left(\frac{\pi}{2} - \theta\right) = \cos \phi \Rightarrow \frac{\pi}{2} - \theta = 2n\pi \pm \phi, n \in I$
 $\Rightarrow \theta \pm \phi - \frac{\pi}{2} = -2n\pi, n \in I; \frac{1}{\pi}\left(\theta \pm \phi - \frac{\pi}{2}\right) = -2n, n \in I$

87. (A) Given, $\sum_{i=1}^{\infty} \tan^{-1}\left(\frac{1}{2i^2}\right) = t = \sum_{i=1}^{\infty} \tan^{-1}\left(\frac{2}{4i^2 - 1 + 1}\right)$
 $\Rightarrow \sum_{i=1}^{\infty} \tan^{-1}\left\{\frac{(2i+1) - (2i-1)}{1 + (2i-1)(2i+1)}\right\}$
 $\Rightarrow (\tan^{-1} 3 - \tan^{-1} 1) + (\tan^{-1} 5 - \tan^{-1} 3)$
 $\quad + \dots + \{\tan^{-1}(2n+1) - \tan^{-1}(2n-1)\}$
 $\therefore t = \lim_{n \rightarrow \infty} \{\tan^{-1}(2n+1) - \tan^{-1} 1\}$
 $= \lim_{n \rightarrow \infty} \tan^{-1}\left(\frac{2n}{1+2n+1}\right) = \frac{\pi}{4} \Rightarrow \tan t = 1$

(B) We have, $\cos \theta_1 = \frac{1 - \tan^2 \frac{\theta_1}{2}}{1 + \tan^2 \frac{\theta_1}{2}} = \frac{a}{b+c}$

Applying componendo and dividendo,

$$\tan^2 \frac{\theta_1}{2} = \frac{b+c-a}{b+c+a}$$

Also, $\cos \theta_3 = \frac{1 - \tan^2 \frac{\theta_3}{2}}{1 + \tan^2 \frac{\theta_3}{2}} = \frac{c}{a+b}$

Applying componendo and dividendo,

$$\tan^2 \frac{\theta_3}{2} = \frac{a+b-c}{a+b+c}$$

$$\therefore \tan^2 \frac{\theta_1}{2} + \tan^2 \frac{\theta_3}{2} = \frac{2b}{a+b+c} = \frac{2b}{3b} = \frac{2}{3}$$

[$\because a, b, c$ are in an AP, so $2b = a + c$]

(C) Line through $(0, 1, 0)$ and perpendicular to plane $x + 2y + 2z = 0$ is given by

$$\frac{x-0}{1} = \frac{y-1}{2} = \frac{z-0}{2} = r \quad [\text{say}]$$

Any point on the line $P(r, 2r+1, 2r)$ be the foot of perpendicular on the straight line, then

$$r \cdot 1 + (2r+1) \cdot 2 + (2r) \cdot 2 = 0 \Rightarrow r = -\frac{2}{9}$$

$$\therefore \text{Coordinates of } P\left(-\frac{2}{9}, \frac{5}{9}, -\frac{4}{9}\right).$$

Hence, required perpendicular distance

$$= \sqrt{\frac{4+25+16}{81}} = \frac{\sqrt{5}}{3} \text{ unit}$$

88. (A) On solving the equations, $x + y = |a|$ and $ax - y = 1$, we get

$$x = \frac{|a|+1}{a+1} > 0 \text{ and } y = \frac{|a|-1}{a+1} > 0$$

\therefore Rays intersect each other in Ist quadrant.

$\therefore x > 0, y > 0 \Rightarrow a + 1 > 0$

$$\text{and } |a|-1 > 0 \Rightarrow a > 1 \Rightarrow a_0 = 1 \Rightarrow \frac{2a_0}{3} = \frac{2}{3}$$

(B) Given, $\vec{a} = \alpha \hat{i} + \beta \hat{j} + \gamma \hat{k} \Rightarrow \vec{a} \cdot \hat{k} = \gamma$

Now, $\hat{k} \times (\hat{k} \times \vec{a}) = (\hat{k} \cdot \vec{a}) \hat{k} - (\hat{k} \cdot \hat{k}) \vec{a}$

$$\Rightarrow \vec{0} = \gamma \hat{k} - (\alpha \hat{i} + \beta \hat{j} + \gamma \hat{k}) \Rightarrow \alpha \hat{i} + \beta \hat{j} = 0 \Rightarrow \alpha = \beta = 0$$

Also, $\alpha + \beta + \gamma = 2 \Rightarrow \gamma = 2$

(C) $\left| \int_0^1 (1-y^2) dy \right| + \left| \int_0^1 (y^2-1) dy \right| = 2 \int_0^1 (1-y^2) dy = \frac{4}{3}$

Also, $\left| \int_0^1 \sqrt{1-x} dx \right| + \left| \int_{-1}^0 \sqrt{1+x} dx \right|$
 $= 2 \int_0^1 \sqrt{1-x} dx = \frac{4}{3}$

(D) $\sin A \sin B \sin C + \cos A \cos B$

$$\leq \sin A \sin B + \cos A \cos B = \cos(A-B)$$

$$\Rightarrow \cos(A-B) \geq 1 \Rightarrow \cos(A-B) = 1 \Rightarrow \sin C = 1$$

89. Since, $x > 0, y < 0$ and $x + y + \frac{x}{y} = \frac{1}{2}$

and $(x+y) \cdot \frac{x}{y} = -\frac{1}{2} \Rightarrow -\frac{y}{2x} + \frac{x}{y} = \frac{1}{2}$

Let $\frac{x}{y} = t \Rightarrow -\frac{1}{2t} + t = \frac{1}{2}$

$$\Rightarrow 2t^2 - 1 = t \Rightarrow 2t^2 - t - 1 = 0$$

$$\therefore t = -\frac{1}{2} \left[\text{but } x > 0 \text{ and } y < 0 \therefore \frac{x}{y} < 0 \right]$$

[neglecting 1]

$$\Rightarrow \frac{x}{y} = -\frac{1}{2} \Rightarrow y = -2x \Rightarrow x + y + \frac{x}{y} = \frac{1}{2}$$

$$\Rightarrow x - 2x - \frac{1}{2} = \frac{1}{2} \Rightarrow x = -1 \text{ and } y = 2$$

90. Given equation is

$$\log_7 \log_5 (\sqrt{x+5} + \sqrt{x}) = 0 \Rightarrow \log_5 (\sqrt{x+5} + \sqrt{x}) = 1$$

$$\Rightarrow \sqrt{x+5} + \sqrt{x} = 5 \Rightarrow \sqrt{x+5} = 5 - \sqrt{x}$$

$$\Rightarrow x+5 = 25 + x - 10\sqrt{x} \Rightarrow 10\sqrt{x} = 20 \Rightarrow \sqrt{x} = 2$$

$$\therefore x = 4$$

91. Given, $n = 40, \bar{x} = 40, \text{var}(x) = 49$

$$\Rightarrow \bar{x} = \frac{\sum f_i x_i}{40} = 40 \Rightarrow \sum f_i x_i = 1600$$

Also, $\text{var}(x) = 49 \Rightarrow \frac{1}{40} \sum f_i (x_i - 40)^2 = 49$

$$\therefore 49 = \frac{1}{40} (\sum x_i^2 f_i) - 2 \sum x_i f_i + 40 \sum f_i$$

$$\Rightarrow 49 = \frac{1}{40} (\sum x_i^2 f_i) - 2(1600) + 40 \times 40$$

$$\therefore \sum x_i^2 f_i = 1649 \times 40$$

Let (21-30) and (31-40) denote the k th and $(k+1)$ th class intervals, respectively.

Then, if before correction f_k and f_{k+1} are frequencies of those intervals, then after correction (2 observations are shifted from (31-40) to (21-30)), frequency of k th interval becomes f_{k+2} and frequency of $(k+1)$ th interval becomes $f_{k+1} - 2$

$$\therefore \bar{x}_{\text{new}} = \frac{1}{40} \left\{ \sum_{i=1}^{40} f_i x_i + (f_k + 2)x_k + (f_{k+1} - 2)x_{k+1} \right\}$$

632 Miscellaneous

$$\begin{aligned} \Rightarrow \bar{x}_{\text{new}} &= \frac{1}{40} \left\{ \sum_{i=1}^{40} f_i x_i \right\} + \frac{2}{40} \{(x_k - x_{k+1})\} \\ &= \frac{1}{40} \sum_{i=1}^{40} f_i x_i + \frac{1}{20} (-10) = 39.5 \\ &= \frac{1}{40} \left[\sum_{i=1}^{40} f_i (x_i - 39.5)^2 + f_k (x_k - 39.5)^2 \right. \\ &\quad \left. + f_{k+1} (x_{k+1} - 39.5)^2 \text{ where } i \neq k, k+1 \right] \\ &= \frac{1}{40} [\sum f_i x_i^2 - 79 f_i x_i + (39.5)^2 f_i] \\ &= \frac{1}{40} \sum_{i=1}^{40} f_i x_i^2 - 79 \left(\frac{1}{40} \right) \sum_{i=1}^{40} f_i x_i + (39.5)^2 \cdot \frac{1}{40} \sum_{i=1}^{40} f_i \\ &= 1649 - 3160 + 1560.25 = 49.25 \end{aligned}$$

92. Mean square deviations = $\frac{1}{n} \sum_{i=1}^n (x_i - c)^2$, about c .

Also, given that mean square deviation about -1 and $+1$ are 7 and 3 , respectively.

$$\begin{aligned} \Rightarrow \frac{1}{n} \sum_{i=1}^n (x_i + 1)^2 &= 7 \text{ and } \frac{1}{n} \sum_{i=1}^n (x_i - 1)^2 = 3 \\ \Rightarrow \sum_{i=1}^n x_i^2 + 2 \sum_{i=1}^n x_i + n &= 7n \text{ and } \sum_{i=1}^n x_i^2 - 2 \sum_{i=1}^n x_i + n = 3n \\ \Rightarrow \sum_{i=1}^n x_i^2 + 2 \sum_{i=1}^n x_i &= 6n \text{ and } \sum_{i=1}^n x_i^2 - 2 \sum_{i=1}^n x_i = 2n \\ \Rightarrow \sum_{i=1}^n x_i - n &\Rightarrow \bar{x} = \frac{\sum_{i=1}^n x_i}{n} = 1 \end{aligned}$$

∴ Standard deviation

$$= \sqrt{\frac{1}{n} \sum_{i=1}^n (x_i - \bar{x})^2} = \sqrt{\frac{1}{n} \sum_{i=1}^n (x_i - 1)^2} = \sqrt{3}$$

93. Let $f(x) = \int_0^x \frac{t^2}{1+t^4} dt \Rightarrow f'(x) = \frac{x^2}{1+x^4} > 0$,

for all $x \in [0, 1]$. $f(x)$ is increasing.

At $x=0$, $f(0)=0$ and at $x=1$, $f(1) = \int_0^1 \frac{t^2}{1+t^4} dt$

Because, $0 < \frac{t^2}{1+t^4} < \frac{1}{2} \Rightarrow \int_0^1 0 \cdot dt < \int_0^1 \frac{t^2}{1+t^4} dt < \int_0^1 \frac{1}{2} \cdot dt$

$\Rightarrow 0 < f(1) < \frac{1}{2}$

Thus, $f(x)$ can be plotted as

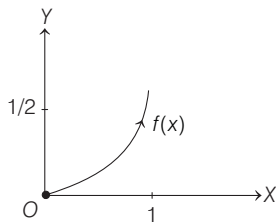

∴ $y = f(x)$ and $y = 2x - 1$ can be shown as

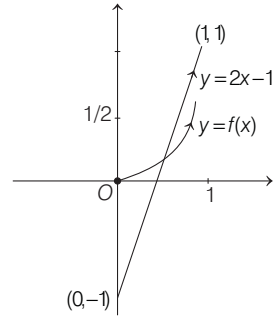

From the graph, the total number of distinct solutions for $x \in (0, 1] = 1$. [as they intersect only at one point]

94. Since, $F'(a) + 2$ is the area bounded by $x=0$, $y=0$, $y=f(x)$ and $x=a$.

∴ $\int_0^a f(x) dx = F'(a) + 2$

Using Newton-Leibnitz formula,

$f(a) = F''(a)$ and $f(0) = F''(0)$... (i)

Given, $F(x) = \int_x^{x^2 + \pi/6} 2 \cos^2 t dt$

On differentiating,

$F'(x) = 2 \cos^2 \left(x^2 + \frac{\pi}{6} \right) \cdot 2x - 2 \cos^2 x \cdot 1$

Again differentiating,

$$\begin{aligned} F''(x) &= 4 \left\{ \cos^2 \left(x^2 + \frac{\pi}{6} \right) - 2x \cos \left(x^2 + \frac{\pi}{6} \right) \sin \left(x^2 + \frac{\pi}{6} \right) 2x \right\} \\ &\quad + \{ 4 \cos x \cdot \sin x \} \\ &= 4 \left\{ \cos^2 \left(x^2 + \frac{\pi}{6} \right) - 4x^2 \cos \left(x^2 + \frac{\pi}{6} \right) \sin \left(x^2 + \frac{\pi}{6} \right) \right\} \\ &\quad + 2 \sin 2x \end{aligned}$$

∴ $F''(0) = 4 \left\{ \cos^2 \left(\frac{\pi}{6} \right) \right\} = 3 \Rightarrow f(0) = 3$

95. PLAN Use of infinite series

i.e. if $y = \sqrt{x \sqrt{x \sqrt{x \dots \infty}}} \Rightarrow y = \sqrt{xy}$,

Given, $6 + \log_3 \left(\frac{1}{3\sqrt{2}} \sqrt{4 - \frac{1}{3\sqrt{2}}} \sqrt{4 - \frac{1}{3\sqrt{2}}} \sqrt{4 - \frac{1}{3\sqrt{2}}} \dots \right)$

Let $\sqrt{4 - \frac{1}{3\sqrt{2}}} \sqrt{4 - \frac{1}{3\sqrt{2}}} \sqrt{\dots} = y$

∴ $y = \sqrt{4 - \frac{1}{3\sqrt{2}}} y \Rightarrow y^2 + \frac{1}{3\sqrt{2}} y - 4 = 0$

$\Rightarrow 3\sqrt{2}y^2 + y - 12\sqrt{2} = 0$

∴ $y = \frac{-1 \pm 17}{6\sqrt{2}}$ or $y = \frac{8}{3\sqrt{2}}$

Now, $6 + \log_3 \left(\frac{1}{3\sqrt{2}} \cdot y \right) = 6 + \log_3 \left(\frac{1}{3\sqrt{2}} \cdot \frac{8}{3\sqrt{2}} \right)$

$= 6 + \log_3 \left(\frac{4}{9} \right) = 6 + \log_3 \left(\frac{3}{2} \right)^{-2} = 6 - 2 \cdot \log_3 \left(\frac{3}{2} \right) = 4$

JEE ADVANCED

Solved Paper 2021

Paper ①

SECTION 1

- This section contains **FOUR (04)** questions.
- Each question has **FOUR** options (a), (b), (c) and (d). **ONLY ONE** of these four options is the correct answer.
- For each question, choose the option corresponding to the correct answer.
- Answer to each question will be evaluated according to the following marking scheme:
Full Marks : +3 If **ONLY** the correct option is chosen;
Zero Marks : 0 If none of the options is chosen (i.e. the question is unanswered);
Negative Marks : -1 In all other cases.

1. Consider a triangle (Δ) whose two sides lie on the X -axis and the line $x + y + 1 = 0$. If the orthocenter of triangle is $(1, 1)$, then the equation of the circle passing through the vertices of the triangle (Δ) is

- (a) $x^2 + y^2 - 3x + y = 0$ (b) $x^2 + y^2 + x + 3y = 0$
(c) $x^2 + y^2 + 2y - 1 = 0$ (d) $x^2 + y^2 + x + y = 0$

2. The area of the region

$$\left\{ (x, y) : 0 \leq x \leq \frac{9}{4}, 0 \leq y \leq 1, x \geq 3y, x + y \geq 2 \right\} \text{ is}$$

- (a) $\frac{11}{32}$ (b) $\frac{35}{96}$ (c) $\frac{37}{96}$ (d) $\frac{13}{32}$

3. Consider three sets $E_1 = \{1, 2, 3\}$, $F_1 = \{1, 3, 4\}$ and $G_1 = \{2, 3, 4, 5\}$. Two elements are chosen at random, without replacement, from the set E_1 and let S_1 denote the set of these chosen elements. Let $E_2 = E_1 - S_1$ and $F_2 = F_1 \cup S_1$. Now, two elements are chosen at random, without replacement, from the set F_2 and let S_2 denote the set of these chosen elements.

Let $G_2 = G_1 \cup S_2$. Finally, two elements are chosen at random, without replacement, from the set G_2 and let S_3 denote the set of these chosen elements.

Let $E_3 = E_2 \cup S_3$. Given that $E_1 = E_3$, let p be the conditional probability of the event $S_1 = \{1, 2\}$. Then, the value of p is

- (a) $\frac{1}{5}$ (b) $\frac{3}{5}$ (c) $\frac{1}{2}$ (d) $\frac{2}{5}$

4. Let $\theta_1, \theta_2, \dots, \theta_{10}$ be positive valued angles (in radian) such that $\theta_1 + \theta_2 + \dots + \theta_{10} = 2\pi$. Define the complex numbers $z_1 = e^{i\theta_1}$, $z_k = z_{k-1}e^{i\theta_k}$ for $k = 2, 3, \dots, 10$, where $i = \sqrt{-1}$. Consider the statements P and Q given below :

$$P : |z_2 - z_1| + |z_3 - z_2| + \dots + |z_{10} - z_9| + |z_1 - z_{10}| \leq 2\pi$$

$$Q : |z_2^2 - z_1^2| + |z_3^2 - z_2^2| + \dots + |z_{10}^2 - z_9^2| + |z_1^2 - z_{10}^2| \leq 4\pi$$

Then,

- (a) P is TRUE and Q is FALSE
(b) Q is TRUE and P is FALSE
(c) Both P and Q are TRUE
(d) Both P and Q are FALSE

2 JEE Advanced Solved Paper 2021

SECTION 2

- This section contains **THREE (03)** question stems.
- There are **TWO (02)** questions corresponding to each question stem.
- The answer to each question is a **NUMERICAL VALUE**.
- For each question, enter the correct numerical value corresponding to the answer in the designated place using the mouse and the on-screen virtual numeric keypad.
- If the numerical value has more than two decimal places, **truncate/round-off** the value to **TWO** decimal places.
- Answer to each question will be evaluated according to the following marking scheme:
Full Marks : +2 If ONLY the correct numerical value is entered at the designated place;
Zero Marks : 0 In all other cases.

Question Stem for Question Nos. 5 and 6

Question Stem

Three numbers are chosen at random, one after another with replacement, from the set $S = \{1, 2, 3, \dots, 100\}$. Let p_1 be the probability that the maximum of chosen numbers is at least 81 and p_2 be the probability that the minimum of chosen numbers is at most 40.

5. The value of $\frac{625}{4} p_1$ is _____.

6. The value of $\frac{125}{4} p_2$ is _____.

Question Stem for Question Nos. 7 and 8

Question Stem

Let α, β and γ be real numbers such that the system of linear equations

$$x + 2y + 3z = \alpha$$

$$4x + 5y + 6z = \beta$$

$$7x + 8y + 9z = \gamma - 1$$

is consistent. Let $|M|$ represent the determinant of the matrix

$$M = \begin{bmatrix} \alpha & 2 & \gamma \\ \beta & 1 & 0 \\ -1 & 0 & 1 \end{bmatrix}$$

Let P be the plane containing all those (α, β, γ) for which the above system of linear equations is consistent, and D be the square of the distance of the point $(0, 1, 0)$ from the plane P .

7. The value of $|M|$ is _____.

8. The value of D is _____.

Question Stem for Question Nos. 9 and 10

Question Stem

Consider the lines L_1 and L_2 defined by

$$L_1 : x\sqrt{2} + y - 1 = 0 \text{ and } L_2 : x\sqrt{2} - y + 1 = 0$$

For a fixed constant λ , let C be the locus of a point P such that the product of the distance of P from L_1 and the distance of P from L_2 is λ^2 . The line $y = 2x + 1$ meets C at two points R and S , where the distance between R and S is $\sqrt{270}$.

Let the perpendicular bisector of RS meet C at two distinct points R' and S' . Let D be the square of the distance between R' and S' .

9. The value of λ^2 is

10. The value of D is

SECTION 3

- This section contains **SIX (06)** questions.
- Each question has **FOUR** options (a), (b), (c) and (d). **ONE OR MORE THAN ONE** of these four option(s) is (are) correct answer(s).
- For each question, choose the option(s) corresponding to (all) the correct answer(s).
- Answer to each question will be evaluated according to the following marking scheme:
 - Full Marks : +4 If only (all) the correct option(s) is(are) chosen;
 - Partial Marks : +3 If all the four options are correct but ONLY three options are chosen;
 - Partial Marks : +2 If three or more options are correct but ONLY two options are chosen, both of which are correct;
 - Partial Marks : +1 If two or more options are correct but ONLY one option is chosen and it is a correct option;
 - Zero Marks : 0 If unanswered;
 - Negative Marks : -2 In all other cases.
- For example, in a question, if (a), (b) and (d) are the ONLY three options corresponding to correct answers, then
 - choosing ONLY (a), (b) and (d) will get +4 marks;
 - choosing ONLY (a) and (b) will get +2 marks;
 - choosing ONLY (b) and (d) will get +2 marks;
 - choosing ONLY (b) will get +1 mark;
 - choosing ONLY (a) and (d) will get +2 marks;
 - choosing ONLY (a) will get +1 mark;
 - choosing ONLY (d) will get +1 mark;
 - choosing no option(s) (i.e. the question is unanswered) will get 0 marks and choosing any other option(s) will get -2 marks.

11. For any 3×3 matrix M , let $|M|$ denote the determinant of M .

Let

$$E = \begin{bmatrix} 1 & 2 & 3 \\ 2 & 3 & 4 \\ 8 & 13 & 18 \end{bmatrix}, P = \begin{bmatrix} 1 & 0 & 0 \\ 0 & 0 & 1 \\ 0 & 1 & 0 \end{bmatrix} \text{ and } F = \begin{bmatrix} 1 & 3 & 2 \\ 8 & 18 & 13 \\ 2 & 4 & 3 \end{bmatrix}$$

If Q is a non-singular matrix of order 3×3 , then which of the following statements is (are) **TRUE**?

- (a) $F = PEP$ and $P^2 = \begin{bmatrix} 1 & 0 & 0 \\ 0 & 1 & 0 \\ 0 & 0 & 1 \end{bmatrix}$
- (b) $|EQ + PFQ^{-1}| = |EQ| + |PFQ^{-1}|$
- (c) $|(EF)^3| > |EF|^2$
- (d) Sum of the diagonal entries of $P^{-1}EP + F$ is equal to the sum of diagonal entries of $E + P^{-1}FP$.

12. Let $f: R \rightarrow R$ be defined by $f(x) = \frac{x^2 - 3x - 6}{x^2 + 2x + 4}$

Then, which of the following statements is(are) **TRUE**?

- (a) f is decreasing in the interval $(-2, -1)$
- (b) f is increasing in the interval $(1, 2)$
- (c) f is onto
- (d) Range of f is $\left[-\frac{3}{2}, 2\right]$

13. Let E, F and G be three events having probabilities $P(E) = \frac{1}{8}$,

$$P(F) = \frac{1}{6} \text{ and } P(G) = \frac{1}{4}, \text{ and let } P(E \cap F \cap G) = \frac{1}{10}.$$

For any event H , if H^C denotes its complement, then which of the following statements is (are) **TRUE**?

- (a) $P(E \cap F \cap G^C) \leq \frac{1}{40}$
- (b) $P(E^C \cap F \cap G) \leq \frac{1}{15}$
- (c) $P(E \cup F \cup G) \leq \frac{13}{24}$
- (d) $P(E^C \cap F^C \cap G^C) \leq \frac{5}{12}$

14. For any 3×3 matrix M , let $|M|$ denote the determinant of M . Let I be the 3×3 identity matrix. Let E and F be two 3×3 matrices such that $(I - EF)$ is invertible. If $G = (I - EF)^{-1}$, then which of the following statements is (are) **TRUE**?

- (a) $|FE| = |I - FE| |FGE|$
- (b) $(I - FE)(I + FGE) = I$
- (c) $EFG = GEF$
- (d) $(I - FE)(I - FGE) = I$

15. For any positive integer n , let $S_n: (0, \infty) \rightarrow R$ be

$$\text{defined by } S_n(x) = \sum_{k=1}^n \cot^{-1} \left(\frac{1 + k(k+1)x^2}{x} \right), \text{ where}$$

for any $x \in R, \cot^{-1}(x) \in (0, \pi)$ and

$$\tan^{-1}(x) \in \left(-\frac{\pi}{2}, \frac{\pi}{2}\right). \text{ Then, which of the following}$$

statements is (are) **TRUE**?

- (a) $S_{10}(x) = \frac{\pi}{2} - \tan^{-1} \left(\frac{1 + 11x^2}{10x} \right)$, for all $x > 0$
- (b) $\lim_{n \rightarrow \infty} \cot(S_n(x)) = x$, for all $x > 0$
- (c) The equation $S_3(x) = \frac{\pi}{4}$ has a root in $(0, \infty)$
- (d) $\tan(S_n(x)) \leq \frac{1}{2}$, for all $n \geq 1$ and $x > 0$

16. For any complex number $w = c + id$, let

$\arg(w) \in (-\pi, \pi]$, where $i = \sqrt{-1}$. Let α and β be real numbers such that for all complex numbers $z = x + iy$ satisfying $\arg\left(\frac{z + \alpha}{z + \beta}\right) = \frac{\pi}{4}$, the ordered pair (x, y) lies on the circle $x^2 + y^2 + 5x - 3y + 4 = 0$

Then, which of the following statements is (are) **TRUE**?

- (a) $\alpha = -1$
- (b) $\alpha\beta = 4$
- (c) $\alpha\beta = -4$
- (d) $\beta = 4$

4 JEE Advanced Solved Paper 2021

SECTION 4

- This section contains **THREE** (03) questions.
- The answer to each question is a **NON-NEGATIVE INTEGER**.
- For each question, enter the correct integer corresponding to the answer using the mouse and the on-screen virtual numeric keypad in the place designated to enter the answer.
- Answer to each question will be evaluated according to the following marking scheme:
Full Marks : +4 If **ONLY** the correct integer is entered;
Zero Marks : 0 In all other cases.

17. For $x \in R$, the number of real roots of the equation

$$3x^2 - 4|x^2 - 1| + x - 1 = 0 \text{ is}$$

18. In a ΔABC , let $AB = \sqrt{23}$, $BC = 3$ and $CA = 4$. Then, the value of $\frac{\cot A + \cot C}{\cot B}$ is

19. Let \mathbf{u} , \mathbf{v} and \mathbf{w} be vectors in three-dimensional space, where \mathbf{u} and \mathbf{v} are unit vectors which are not perpendicular to each other and $\mathbf{u} \cdot \mathbf{w} = 1$, $\mathbf{v} \cdot \mathbf{w} = 1$, $\mathbf{w} \cdot \mathbf{w} = 4$

If the volume of the parallelepiped, whose adjacent sides are represented by the vectors \mathbf{u} , \mathbf{v} and \mathbf{w} , is $\sqrt{2}$, then the value of $|3\mathbf{u} + 5\mathbf{v}|$ is

Paper 2

SECTION 1

- This section contains **SIX** (06) questions.
- Each question has **FOUR** options (a), (b), (c) and (d). **ONE OR MORE THAN ONE** of these four option(s) is (are) correct answer(s).
- For each question, choose the option(s) corresponding to (all) the correct answer(s).
- Answer to each question will be evaluated according to the following marking scheme:
Full Marks : +4 If only (all) the correct option(s) is(are) chosen;
Partial Marks : +3 If all the four options are correct but **ONLY** three options are chosen;
Partial Marks : +2 If three or more options are correct but **ONLY** two options are chosen, both of which are correct;
Partial Marks : +1 If two or more options are correct but **ONLY** one option is chosen and it is a correct option;
Zero Marks : 0 If unanswered;
Negative Marks : -2 In all other cases.
- For example, in a question, if (a), (b) and (d) are the **ONLY** three options corresponding to correct answers, then
 choosing **ONLY** (a), (b) and (d) will get +4 marks; choosing **ONLY** (a) and (b) will get +2 marks;
 choosing **ONLY** (a) and (d) will get +2 marks; choosing **ONLY** (b) and (d) will get +2 marks;
 choosing **ONLY** (a) will get +1 mark; choosing **ONLY** (b) will get +1 mark;
 choosing **ONLY** (d) will get +1 mark;
 choosing no option(s) (i.e. the question is unanswered) will get 0 marks and choosing any other option(s) will get -2 marks.

1. Let $S_1 = \{(\hat{\mathbf{i}}, \hat{\mathbf{j}}, \hat{\mathbf{k}}) : \hat{\mathbf{i}}, \hat{\mathbf{j}}, \hat{\mathbf{k}} \in \{1, 2, \dots, 10\}\}$,

$$S_2 = \{(\hat{\mathbf{i}}, \hat{\mathbf{j}}) : 1 \leq \hat{\mathbf{i}} < \hat{\mathbf{j}} + 2 \leq 10, \hat{\mathbf{i}}, \hat{\mathbf{j}} \in \{1, 2, \dots, 10\}\}$$

$$S_3 = \{(\hat{\mathbf{i}}, \hat{\mathbf{j}}, \hat{\mathbf{k}}, l) : 1 \leq \hat{\mathbf{i}} < \hat{\mathbf{j}} < \hat{\mathbf{k}} < l, \hat{\mathbf{i}}, \hat{\mathbf{j}}, \hat{\mathbf{k}}, l \in \{1, 2, \dots, 10\}\}$$

and $S_4 = \{(\hat{\mathbf{i}}, \hat{\mathbf{j}}, \hat{\mathbf{k}}, l) : \hat{\mathbf{i}}, \hat{\mathbf{j}}, \hat{\mathbf{k}}$ and l are distinct elements in $\{1, 2, \dots, 10\}\}$.

If the total number of elements in the set S_r is n_r , $r = 1, 2, 3, 4$, then which of the following statements is (are) TRUE?

- (a) $n_1 = 1000$ (b) $n_2 = 44$
 (c) $n_3 = 220$ (d) $\frac{n_4}{12} = 420$

2. Consider a ΔPQR having sides of lengths p , q and r opposite to the angles P , Q and R , respectively. Then, which of the following statements is (are) TRUE?

- (a) $\cos P \geq 1 - \frac{p^2}{2qr}$
 (b) $\cos R \geq \left(\frac{q-r}{p+q}\right)\cos P + \left(\frac{p-r}{p+q}\right)\cos Q$
 (c) $\frac{q+r}{p} < 2 \frac{\sqrt{\sin Q \sin R}}{\sin P}$
 (d) If $p < q$ and $p < r$, then $\cos Q > \frac{p}{r}$ and $\cos R > \frac{p}{q}$

3. Let $f: \left[-\frac{\pi}{2}, \frac{\pi}{2}\right] \rightarrow \mathbb{R}$ be a continuous function such that

$$f(0) = 1 \text{ and } \int_0^{\frac{\pi}{3}} f(t) dt = 0$$

Then, which of the following statements is (are) TRUE?

(a) The equation $f(x) - 3\cos 3x = 0$ has at least one solution in $\left(0, \frac{\pi}{3}\right)$.

(b) The equation $f(x) - 3\sin 3x = -\frac{6}{\pi}$ has at least one solution in $\left(0, \frac{\pi}{3}\right)$.

(c) $\lim_{x \rightarrow 0} \frac{x \int_0^x f(t) dt}{1 - e^{x^2}} = -1$.

(d) $\lim_{x \rightarrow 0} \frac{\sin x \int_0^x f(t) dt}{x^2} = -1$.

4. For any real numbers α and β , let $y_{\alpha, \beta}(x), x \in \mathbb{R}$, be the

solution of the differential equation $\frac{dy}{dx} + \alpha y = x e^{\beta x}, y(1) = 1$.

Let $S = \{y_{\alpha, \beta}(x) : \alpha, \beta \in \mathbb{R}\}$. Then, which of the following functions belong(s) to the set S ?

(a) $f(x) = \frac{x^2}{2} e^{-x} + \left(e - \frac{1}{2}\right) e^{-x}$

(b) $f(x) = -\frac{x^2}{2} e^{-x} + \left(e + \frac{1}{2}\right) e^{-x}$

(c) $f(x) = \frac{e^x}{2} \left(x - \frac{1}{2}\right) + \left(e - \frac{e^2}{4}\right) e^{-x}$

(d) $f(x) = \frac{e^x}{2} \left(\frac{1}{2} - x\right) + \left(e + \frac{e^2}{4}\right) e^{-x}$

5. Let O be the origin and $\mathbf{OA} = 2\hat{i} + 2\hat{j} + \hat{k}$,

$\mathbf{OB} = \hat{i} - 2\hat{j} + 2\hat{k}$ and $\mathbf{OC} = \frac{1}{2}(\mathbf{OB} - \lambda \mathbf{OA})$, for some

$\lambda > 0$. If $|\mathbf{OB} \times \mathbf{OC}| = \frac{9}{2}$, then which of the following statements is (are) TRUE?

(a) Projection of \mathbf{OC} on \mathbf{OA} is $-\frac{3}{2}$.

(b) Area of the ΔOAB is $\frac{9}{2}$.

(c) Area of the ΔABC is $\frac{9}{2}$.

(d) The acute angle between the diagonals of the parallelogram with adjacent sides \mathbf{OA} and \mathbf{OC} is $\frac{\pi}{3}$.

6. Let E denote the parabola $y^2 = 8x$. Let $P = (-2, 4)$, and let Q and Q' be two distinct points on E such that the lines PQ and PQ' are tangents to E . Let F be the focus of E . Then, which of the following statements is (are) TRUE ?

(a) The ΔPFQ is a right-angled triangle.

(b) The $\Delta QPQ'$ is a right-angled triangle.

(c) The distance between P and F is $5\sqrt{2}$.

(d) F lies on the line joining Q and Q' .

SECTION 2

- This section contains **THREE (03)** question stems.
- There are **TWO (02)** questions corresponding to each question stem.
- The answer to each question is a **NUMERICAL VALUE**.
- For each question, enter the correct numerical value corresponding to the answer in the designated place using the mouse and the on-screen virtual numeric keypad.
- If the numerical value has more than two decimal places, **truncate/round-off** the value to **TWO** decimal places.
- Answer to each question will be evaluated according to the following marking scheme:

Full Marks	: +2	If ONLY the correct numerical value is entered at the designated place;
Zero Marks	: 0	In all other cases.

Question Stem for Question Nos. 7 and 8

Question Stem

Consider the region $R = \{(x, y) \in \mathbb{R} \times \mathbb{R} : x \geq 0 \text{ and } y^2 \leq 4 - x\}$. Let F be the family of all circles that are contained in R and have centers on the X -axis. Let C be the circle that has largest radius among the circles in F . Let (α, β) be a point, where the circle C meets the curve $y^2 = 4 - x$.

7. The radius of the circle C is _____ .
8. The value of α is _____ .

Question Stem for Question Nos. 9 and 10

Question Stem

Let $f_1 : (0, \infty) \rightarrow \mathbb{R}$ and $f_2 : (0, \infty) \rightarrow \mathbb{R}$ be defined by $f_1(x) = \int_0^x \prod_{j=1}^{21} (t - j)^j dt, x > 0$ and $f_2(x) = 98(x - 1)^{50} - 600(x - 1)^{49} + 2450, x > 0$, where for any positive integer n and real numbers $a_1, a_2, \dots, a_n, \prod_{i=1}^n a_i$ denotes the product of a_1, a_2, \dots, a_n . Let m_i and n_i , respectively, denote the number of points of local minima and the number of points of local maxima of function $f_i, i = 1, 2$ in the interval $(0, \infty)$.

6 JEE Advanced Solved Paper 2021

9. The value of $2m_1 + 3n_1 + m_1n_1$ is _____.

10. The value of $6m_2 + 4n_2 + 8m_2n_2$ is _____.

Question Stem for Question Nos. 11 and 12

Question Stem

Let $g_i : \left[\frac{\pi}{8}, \frac{3\pi}{8} \right] \rightarrow R, i = 1, 2$, and $f : \left[\frac{\pi}{8}, \frac{3\pi}{8} \right] \rightarrow R$ be

functions such that $g_1(x) = 1, g_2(x) = |4x - \pi|$ and

$f(x) = \sin^2 x$, for all $x \in \left[\frac{\pi}{8}, \frac{3\pi}{8} \right]$. Define

$$S_i = \int_{\frac{\pi}{8}}^{\frac{3\pi}{8}} f(x) \cdot g_i(x) dx, i = 1, 2$$

11. The value of $\frac{16S_1}{\pi}$ is _____.

12. The value of $\frac{48S_2}{\pi^2}$ is _____.

SECTION 3

- This section contains **TWO (02)** paragraphs. Based on each paragraph, there are TWO (02) questions.
- Each question has **FOUR** options (a), (b), (c) and (d). **ONLY ONE** of these four options is the correct answer.
- For each question, choose the option corresponding to the correct answer.
- Answer to each question will be evaluated according to the following marking scheme:

Full Marks : +3 If ONLY the correct option is chosen;

Zero Marks : 0 If none of the options is chosen (i.e., the question is unanswered);

Negative Marks : -1 In all other cases.

Paragraph

Let $M = \{(x, y) \in R \times R : x^2 + y^2 \leq r^2\}$,

where $r > 0$. Consider the geometric progression $a_n = \frac{1}{2^{n-1}}$,

$n = 1, 2, 3, \dots$. Let $S_0 = 0$ and, for $n \geq 1$, let S_n denote the sum of the first n terms of this progression. For $n \geq 1$, let C_n denote the circle with center $(S_{n-1}, 0)$ and radius a_n , and D_n denote the circle with center (S_{n-1}, S_{n-1}) and radius a_n .

13. Consider M with $r = \frac{1025}{513}$. Let k be the number of all those

circles C_n that are inside M . Let l be the maximum possible number of circles among these k circles such that no two circles intersect. Then,

(a) $k + 2l = 22$

(b) $2k + l = 26$

(c) $2k + 3l = 34$

(d) $3k + 2l = 40$

14. Consider M with $r = \frac{(2^{199} - 1)\sqrt{2}}{2^{198}}$. The number of all those

circles D_n that are inside M is

(a) 198

(b) 199

(c) 200

(d) 201

Paragraph

Let $\psi_1 : [0, \infty) \rightarrow R, \psi_2 : [0, \infty) \rightarrow R, f : [0, \infty) \rightarrow R$ and $g : [0, \infty) \rightarrow R$ be functions such that $f(0) = g(0) = 0$,

$$\psi_1(x) = e^{-x} + x, x \geq 0,$$

$$\psi_2(x) = x^2 - 2x - 2e^{-x} + 2, x \geq 0,$$

$$f(x) = \int_{-x}^x (|t| - t^2) e^{-t^2} dt, x > 0$$

$$\text{and } g(x) = \int_0^{x^2} \sqrt{t} e^{-t} dt, x > 0.$$

15. Which of the following statements is TRUE ?

(a) $f(\sqrt{\ln 3}) + g(\sqrt{\ln 3}) = \frac{1}{3}$

(b) For every $x > 1$, there exists an $\alpha \in (1, x)$ such that $\psi_1(x) = 1 + \alpha x$

(c) For every $x > 0$, there exists a $\beta \in (0, x)$ such that $\psi_2(x) = 2x(\psi_1(\beta) - 1)$.

(d) f is an increasing function on the interval $\left[0, \frac{3}{2}\right]$.

16. Which of the following statements is TRUE?

(a) $\psi_1(x) \leq 1$, for all $x > 0$

(b) $\psi_2(x) \leq 0$, for all $x > 0$

(c) $f(x) \geq 1 - e^{-x^2} - \frac{2}{3}x^3 + \frac{2}{5}x^5$, for all $x \in \left(0, \frac{1}{2}\right)$

(d) $g(x) \leq \frac{2}{3}x^3 - \frac{2}{5}x^5 + \frac{1}{7}x^7$, for all $x \in \left(0, \frac{1}{2}\right)$.

SECTION 4

- This section contains **THREE (03)** questions.
- The answer to each question is a **NON-NEGATIVE INTEGER**.
- For each question, enter the correct integer corresponding to the answer using the mouse and the on-screen virtual numeric keypad in the place designated to enter the answer.
- Answer to each question will be evaluated according to the following marking scheme:
Full Marks : +4 If ONLY the correct integer is entered;
Zero Marks : 0 In all other cases.

17. A number is chosen at random from the set $\{1, 2, 3, \dots, 2000\}$. Let p be the probability that the chosen number is a multiple of 3 or a multiple of 7. Then, the value of $500p$ is ____.

18. Let E be the ellipse $\frac{x^2}{16} + \frac{y^2}{9} = 1$. For any three distinct points P, Q and Q' on E , let $M(P, Q)$ be the mid-point of the line segment joining P and Q , and $M(P, Q')$ be the mid-point of the line segment joining P and Q' . Then, the maximum

possible value of the distance between $M(P, Q)$ and $M(P, Q')$, as P, Q and Q' vary on E , is ____.

19. For any real number x , let $[x]$ denote the largest integer less than or equal to x . If

$$I = \int_0^{10} \left\lfloor \sqrt{\frac{10x}{x+1}} \right\rfloor dx, \text{ then the value of } 9I \text{ is } \underline{\hspace{2cm}}.$$

Answer with Explanations

Paper 1

1. (b) $x^2 + y^2 + x + 3y = 0$.

Method (1)

As we know that, mirror image of orthocenter lie, on circumcircle.
 Image of $(1, 1)$, in X -axis is $(1, -1)$.
 and Image of $(1, 1)$ in $x + y + 1 = 0$ is $(-2, -2)$.
 \therefore The required circle will be passing through both $(1, -1)$ and $(-2, -2)$.
 \therefore Only $x^2 + y^2 + x + 3y = 0$ satisfy both.

Method (2)

One of the vertex is the point of intersection of X -axis and the line $x + y + 1 = 0$, say A , which is $A \equiv (-1, 0)$.

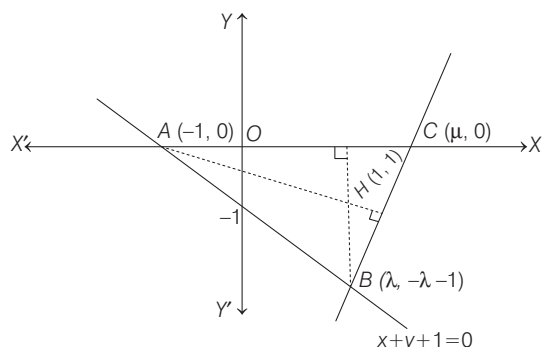

Let vertex $B(\lambda, -\lambda - 1)$.

Since, $AC \perp BH$

$$\therefore \lambda = 1 \Rightarrow B \equiv (1, -2)$$

Let vertex C be $(\mu, 0)$.

$$\therefore AH \perp BC$$

$$\therefore (\text{Slope of } AH) \times (\text{Slope of } BC) = -1$$

$$\Rightarrow \frac{1}{2} \times \frac{2}{\mu - 1} = -1 \Rightarrow \mu = 0$$

Now, centroid of ΔABC is $(0, -\frac{2}{3})$.

As we know that, centroid (G) divides the line joining circumcentre (O) and orthocentre (H) in the ratio $1 : 2$.

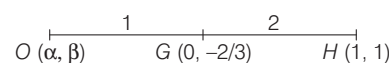

$$2\alpha + 1 = 0 \text{ and } 2\beta + 1 = -2 \Rightarrow \alpha = -1/2 \text{ and } \beta = -3/2$$

$$\Rightarrow \text{Circumcentre} = \left(\frac{-1}{2}, \frac{-3}{2}\right)$$

\therefore Equation of circumcircle which is passing through $C(0, 0)$ is $x^2 + y^2 + x + 3y = 0$

Method (3)

Equation of circle passing through $C(0, 0)$ is

$$x^2 + y^2 + 2gx + 2fy = 0 \quad \dots (i)$$

Since Eq. (i), also passes through $(-1, 0)$ and $(1, -2)$.

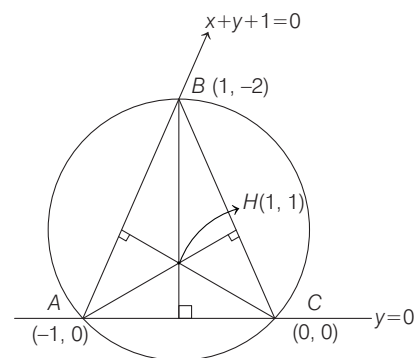

8 JEE Advanced Solved Paper 2021

Then, $1 - 2g = 0 \Rightarrow g = 1/2$
 and $5 + 1 - 4f = 0 \Rightarrow f = 3/2$
 \therefore Equation of circumcircle is $x^2 + y^2 + 2 \times \frac{1}{2}x + 2 \times \frac{3}{2}y = 0$

i.e. $x^2 + y^2 + x + 3y = 0$

2. (a) $\frac{11}{32}$

Method (1)

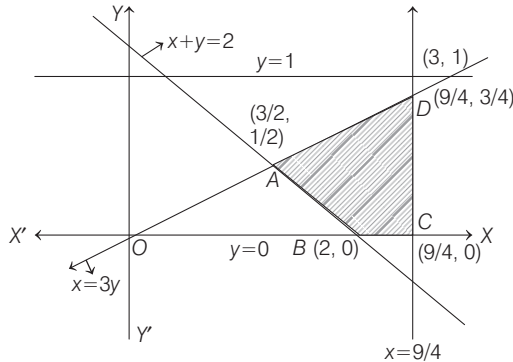

Required area = Shaded region

On solving $x + y = 2$ and $x = 3y$, we get

$$A \equiv \left(\frac{3}{2}, \frac{1}{2}\right)$$

On solving $y = 0$ and $x + y = 2$, we get

$$B \equiv (2, 0)$$

On solving $x = 9/4$ and $x = 3y$, we get

$$D \equiv (9/4, 3/4)$$

and $C \equiv (9/4, 0) \rightarrow$ (obviously)

So, required area = shaded region

$$\begin{aligned} &= \frac{1}{2} \begin{vmatrix} 3/2 & 1/2 & 1 \\ 2 & 0 & 1 \\ 9/4 & 3/4 & 1 \end{vmatrix} + \frac{1}{2} \times \left(\frac{9}{4} - 2\right) \times 3/4 \\ &= \frac{1}{2} \times \left\{ -2\left(\frac{1}{2} - \frac{3}{4}\right) - \left(\frac{9}{8} - \frac{9}{8}\right) \right\} + \frac{1}{2} \times \frac{1}{4} \times \frac{3}{4} \\ &= \frac{3}{4} - \frac{1}{2} \times \frac{2}{2} + \frac{3}{32} \\ &= \frac{8 \times 1}{8 \times 4} + \frac{3}{32} = \frac{8+3}{32} = \frac{11}{32} \text{ sq units} \end{aligned}$$

Method (2)

Required area = Area of $\triangle OCD$ - Area of $\triangle OBA$

$$\begin{aligned} &= \frac{1}{2} \times \left(\frac{9}{4} - 0\right) \times \frac{3}{4} - \frac{1}{2} \times (2-0) \times \frac{1}{2} \\ &= \frac{27}{32} - \frac{1}{2} = \frac{27}{32} - \frac{16}{32} = \frac{11}{32} \end{aligned}$$

3. (a) $\frac{1}{5}$

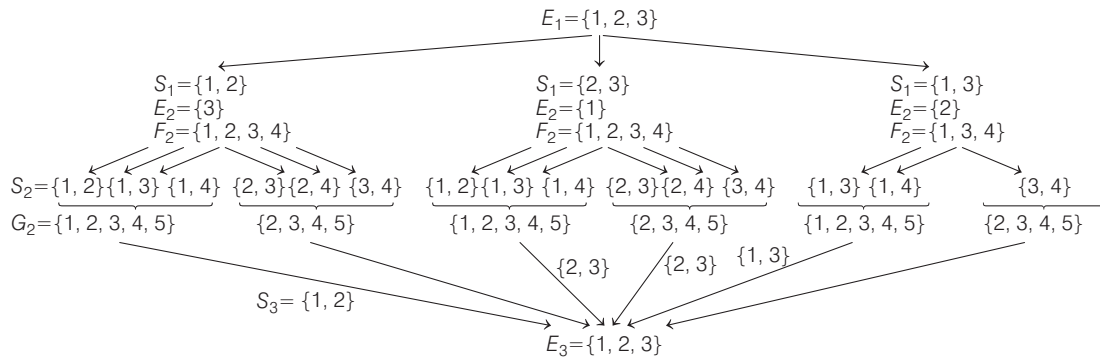

To find : Probability $P = \frac{P(S_1 \cap (E_1 = E_3))}{P(E_1 = E_3)} = \frac{P(A_{1,2})}{P(A)}$

where $P(A) = P(A_{1,2}) + P(A_{1,3}) + P(A_{2,3})$

Also, $A_{1,2}$ represents 1, 2 chosen at start and similarly others.

Now, $P(A_{1,2}) = \frac{1}{3} \times \frac{1 \times {}^3C_1}{{}^4C_2} \times \frac{1}{{}^5C_2} = \frac{1}{3} \times \frac{3}{6} \times \frac{1}{10} = \frac{1}{3} \times \frac{1}{2} \times \frac{1}{10}$

$$P(A_{1,3}) = \frac{1}{3} \times \frac{1 \times {}^2C_1}{{}^4C_2} \times \frac{1}{{}^5C_2} = \frac{1}{3} \times \frac{2}{3} \times \frac{1}{10}$$

$$\begin{aligned} P(A_{2,3}) &= \frac{1}{3} \times \left[\frac{{}^3C_2 \times 1}{{}^4C_2} \times \frac{1}{{}^4C_2} + \frac{1 \times {}^3C_1}{{}^4C_2} \times \frac{1}{{}^5C_2} \right] \\ &= \frac{1}{3} \times \left[\frac{3}{6} \times \frac{1}{6} + \frac{3}{6} \times \frac{1}{10} \right] = \frac{1}{3} \left[\frac{1}{2} \times \frac{1}{6} + \frac{1}{2} \times \frac{1}{10} \right] \end{aligned}$$

$$\begin{aligned} P(A) &= \frac{1}{3} \left[\frac{1}{2} \times \frac{1}{10} + \frac{1}{2} \times 0 + \frac{1}{2} \times \frac{1}{10} + \frac{1}{2} \times \frac{1}{6} + \frac{2}{3} \times \frac{1}{10} + \frac{1}{3} \times 0 \right] \\ &= \frac{1}{3} \left[\frac{1}{4} \right] = \frac{1}{12} \end{aligned}$$

$$\begin{aligned} \therefore \text{Required probability} &= \frac{\frac{1}{3} \left(\frac{1}{2} \times \frac{1}{10} \right)}{\frac{1}{12}} \quad \left[\because P = \frac{P(A_{1,2})}{P(A)} \right] \\ &= \frac{1}{60} \times \frac{12}{1} = \frac{1}{5} \end{aligned}$$

4. (c) Both P and Q are true.

\therefore Length of direct distance \leq length of arc

i.e. $|z_2 - z_1| =$ length of line $AB \leq$ length of arc AB .

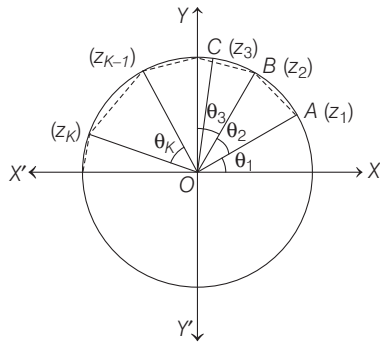

$|z_3 - z_2| = \text{length of line } BC \leq \text{length of arc } BC.$
 $\therefore \text{Sum of length of these 10 lines} \leq \text{sum of length of arcs (i.e. } 2\pi)$
 (because $\theta_1 + \theta_2 + \theta_3 + \dots + \theta_{10} = 2\pi$ given)
 $\therefore |z_2 - z_1| + |z_3 - z_2| + \dots + |z_1 - z_{10}| \leq 2\pi \rightarrow P$ is true.
 And $|z_k^2 - z_{k-1}^2| = |z_k - z_{k-1}| |z_k + z_{k-1}|$
 As we know that,
 $|z_k + z_{k-1}| \leq |z_k| + |z_{k-1}| \leq 2$
 $\therefore |z_k^2 - z_{k-1}^2| + |z_3^2 - z_2^2| + \dots + |z_1^2 - z_{10}^2| \leq 2$
 $(|z_2 - z_1| + |z_3 - z_2| + \dots + |z_1 - z_{10}|)$
 $\leq 2(2\pi)$
 $\leq 4\pi \rightarrow Q$ is true.

5. (76.25)

$p_1 = 1 - p$ (all 3 numbers are ≤ 80)
 $= 1 - \left(\frac{80}{100}\right)^3 = \frac{125 - 64}{125} = \frac{61}{125}$
 So, $\frac{625p_1}{4} = \frac{625}{4} \times \frac{61}{125} = \frac{5}{4} \times 61 = 76.25$

6. (24.50)

$p_2 = 1 - p$ (all three numbers are > 40)
 $= 1 - \left(\frac{60}{100}\right)^3 = 1 - \frac{27}{125} = \frac{98}{125}$
 So, $\frac{125p_2}{4} = \frac{125}{4} \times \frac{98}{125} = \frac{98}{4} = 24.50$

7. (1)

8. (1.50)

$7x + 8y + 9z - (\gamma - 1) = A(4x + 5y + 6z - \beta)$
 $+ B(x + 2y + 3z - \alpha)$

On equating the coefficients,
 $4A + B = 7$... (i)
 $5A + 2B = 8$... (ii)
 and $-(\gamma - 1) = -A\beta - \alpha B$... (iii)
 On solving Eqs. (i) and (ii), we get
 $A = 2$ and $B = -1$
 From Eq. (iii), we get
 $-\gamma + 1 = -2\beta - \alpha(-1)$
 $\Rightarrow \alpha - 2\beta + \gamma = 1$... (iv)

Now, determinant of

$M = |M| = \begin{vmatrix} \alpha & 2 & \gamma \\ \beta & 1 & 0 \\ -1 & 0 & 1 \end{vmatrix} = \alpha - 2\beta + \gamma = 1$ [from Eq. (iv)]

Equation of plane P is given by

$x - 2y + z = 1$

Hence, perpendicular distance of the point $(0, 1, 0)$ from the

plane $P = \frac{|0 - 2 \times 1 + 0 - 1|}{\sqrt{1^2 + (-2)^2 + 1^2}} = \frac{|3|}{\sqrt{6}}$

$\Rightarrow D = \left(\frac{|3|}{\sqrt{6}}\right)^2 = \frac{9}{6} = 1.5$

9. (9)

10. (77.14)

According to the question,

$C: \left| \frac{x\sqrt{2} + y - 1}{\sqrt{3}} \right| = \left| \frac{x\sqrt{2} - y + 1}{\sqrt{3}} \right| = \lambda^2$

$\Rightarrow C: \frac{|(x\sqrt{2})^2 - (y-1)^2|}{\sqrt{3} \times \sqrt{3}} = \lambda^2$

$\Rightarrow C: |2x^2 - (y-1)^2| = 3\lambda^2$

Let $R \equiv (x_1, y_1)$ and $S(x_2, y_2)$

$\therefore C$ cuts $y - 1 = 2x$ at R and S .

So, $|2x^2 - 4x^2| = 3\lambda^2$

$\Rightarrow x = \pm \sqrt{\frac{3}{2}} |\lambda|$

$\therefore |x_1 - x_2| = \sqrt{6} |\lambda|$

and $|y_1 - y_2| = 2|x_1 - x_2| = 2\sqrt{6} |\lambda|$

$\therefore RS^2 = 270$ (given)

$\Rightarrow (x_1 - x_2)^2 + (y_1 - y_2)^2 = 270$

$\Rightarrow (\sqrt{6}\lambda)^2 + (2\sqrt{6}|\lambda|)^2 = 270$

$\Rightarrow 30\lambda^2 = 270 \Rightarrow \lambda^2 = 9$

Now, mid-point of RS is $\left(\frac{x_1 + x_2}{2}, \frac{y_1 + y_2}{2}\right) \equiv (0, 1)$

and slope of $RS = 2$ and slope of $R'S' = \frac{-1}{2}$

\therefore Equation of $R'S'$: $y - 1 = -\frac{1}{2}x$ i.e. $2y - 2 = -x$

$\Rightarrow x + 2y - 2 = 0$

On solving $x + 2y - 2 = 0$ with C , we get

$x^2 = \frac{12}{7}\lambda^2 \Rightarrow |x_1 - x_2| = 2\sqrt{\frac{12}{7}} |\lambda|$

and $|y_1 - y_2| = \frac{1}{2}|x_1 - x_2| = \sqrt{\frac{12}{7}} |\lambda|$

Hence, $D \equiv (R'S')^2 = (x_1 - x_2)^2 + (y_1 - y_2)^2$

$= \frac{12}{7} \times 9 \times 5 = \frac{12 \times 45}{7} \approx 77.14$

10 JEE Advanced Solved Paper 2021

11. (a, b and d)

For option (a)

$$PEP = \begin{bmatrix} 1 & 0 & 0 \\ 0 & 0 & 1 \\ 0 & 1 & 0 \end{bmatrix} \begin{bmatrix} 1 & 2 & 3 \\ 2 & 3 & 4 \\ 8 & 13 & 18 \end{bmatrix} \begin{bmatrix} 1 & 0 & 0 \\ 0 & 0 & 1 \\ 0 & 1 & 0 \end{bmatrix}$$

$$= \begin{bmatrix} 1 & 2 & 3 \\ 8 & 13 & 18 \\ 2 & 3 & 4 \end{bmatrix} \begin{bmatrix} 1 & 0 & 0 \\ 0 & 0 & 1 \\ 0 & 1 & 0 \end{bmatrix} = \begin{bmatrix} 1 & 3 & 2 \\ 8 & 18 & 13 \\ 2 & 4 & 3 \end{bmatrix} = F$$

and $P^2 = \begin{bmatrix} 1 & 0 & 0 \\ 0 & 0 & 1 \\ 0 & 1 & 0 \end{bmatrix} \begin{bmatrix} 1 & 0 & 0 \\ 0 & 0 & 1 \\ 0 & 1 & 0 \end{bmatrix} = \begin{bmatrix} 1 & 0 & 0 \\ 0 & 1 & 0 \\ 0 & 0 & 1 \end{bmatrix}$

Hence, option (a) is correct.

For option (b)

$$|EQ + PFQ^{-1}| = |EQ| + |PFQ^{-1}| \quad \dots (i)$$

$$\because |E| = 0 \text{ and } |F| = 0 \text{ and } |Q| \neq 0$$

$$\therefore |EQ| = |E| |Q| = 0$$

and $|PFQ^{-1}| = \frac{|P| |F|}{|Q|} = 0$

Let $R = EQ + PFQ^{-1} \quad \dots (ii)$

$$\Rightarrow RQ = EQ^2 + PF = EQ^2 + P^2EP = EQ^2 + EP \quad [\because P^2 = I]$$

$$= E(Q^2 + P)$$

$$\Rightarrow |RQ| = |E(Q^2 + P)|$$

$$\Rightarrow |R| |Q| = |E| |Q^2 + P| = 0 \quad [\because |E| = 0]$$

$$\Rightarrow |R| = 0 \text{ (as } |Q| \neq 0) \quad \dots (iii)$$

From Eqs. (ii) and (iii), we get Eq. (i) is true.

Hence, option (b) is correct.

For option (c)

$$|(EF)^3| > |EF|^2$$

i.e. $0 > 0$ which is false.

For option (d)

$$\because P^2 = I \Rightarrow P^{-1} = P$$

$$\therefore P^{-1}FP = PFP = PPEPP = E$$

So, $E + P^{-1}FP = E + E = 2E$

$$\Rightarrow \text{Tr}(E + P^{-1}FP) = \text{Tr}(2E) = 2\text{Tr}(E) \quad \dots (iv)$$

and $P^{-1}EP + F$

$$\Rightarrow PEP + F = 2PEP \quad [\because F = PEP]$$

$$\therefore \text{Tr}(2PEP) = 2\text{Tr}(PEP) = 2\text{Tr}(F) = 2\text{Tr}(E) \quad \dots (v)$$

From Eqs. (iv) and (v), option (d) is also correct.

12. (a and b) Given,

$$f(x) = \frac{x^2 - 3x - 6}{x^2 + 2x + 4} \quad \dots (i)$$

$$\Rightarrow f'(x) = \frac{(x^2 + 2x + 4)(2x - 3) - (x^2 - 3x - 6)(2x + 2)}{(x^2 + 2x + 4)^2}$$

$$\Rightarrow f'(x) = \frac{5x(x + 4)}{(x^2 + 2x + 4)^2}$$

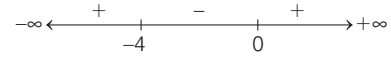

Sign scheme for $f'(x)$

Here, f is decreasing in the interval $(-2, -1)$ and f is increasing in the interval $(1, 2)$.

Now, $f(-4) = \frac{11}{6}, f(0) = \frac{-3}{2}$ [from Eq. (i)]

and $\lim_{x \rightarrow \pm\infty} f(x) = 1$

$$\therefore \text{Range} = \left[\frac{-3}{2}, \frac{11}{6} \right]$$

Hence, $f(x)$ is into.

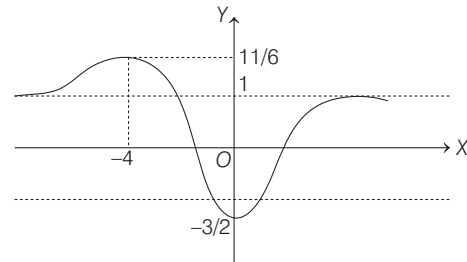

$f(x)$ has local maxima at $x = -4$

and local minima at $x = 0$.

13. (a, b and c)

For option (a)

$$P(E \cap F \cap G^c) = P(E \cap F) - P(E \cap F \cap G) \leq P(E) - P(E \cap F \cap G)$$

$$= \frac{1}{8} - \frac{1}{10} = \frac{1}{40}$$

For option (b)

$$P(E^c \cap F \cap G) = P(F \cap G) - P(E \cap F \cap G) \leq P(F) - P(E \cap F \cap G)$$

$$= \frac{1}{6} - \frac{1}{10} = \frac{1}{15}$$

For option (c)

$$P(E \cup F \cup G) \leq P(E) + P(F) + P(G)$$

$$= \frac{1}{8} + \frac{1}{6} + \frac{1}{4} = \frac{3 + 4 + 6}{24} = \frac{13}{24}$$

For option (d)

$$P(E^c \cap F^c \cap G^c) = 1 - P(E \cap F \cap G) \geq 1 - \frac{13}{24}$$

$$P(E^c \cap F^c \cap G^c) \geq \frac{11}{24} > \frac{5}{12}$$

14. (a, b and c)

$$\because I - EF = G^{-1} \Rightarrow G - GEF = I \quad \dots (i)$$

$$\text{and } G - EFG = I \quad \dots (ii)$$

Clearly, $GEF = EFG \rightarrow$ option (c) is correct.

Also, $(I - FE)(I + FGE)$

$$= I - FE + FGE - FEFGE$$

$$= I - FE + FGE - F(G - I)E$$

$$= I - FE + FGE - FGE + FE$$

$$= I \rightarrow \text{option (b) is correct but option (d) is incorrect.}$$

$$\because (I - FE)(I - FGE) = I - FE - FGE + F(G - I)E$$

$$= I - 2FE$$

Now, $(I - FE) (-FGE) = -FE$

$$\Rightarrow |I - FE| |FGE| = |FE|$$

→ option (a) is correct.

15. (a and b) For option (a) $S_n(x) = \sum_{k=1}^n \cot^{-1} \left[\frac{1 + k(k+1)x^2}{x} \right]$

can be written as

$$\begin{aligned} S_n(x) &= \sum_{k=1}^n \tan^{-1} \left[\frac{(k+1)x - kx}{1 + kx \cdot (k+1)x} \right] \\ &= \sum_{k=1}^n [\tan^{-1}(k+1)x - \tan^{-1}(kx)] \\ &= \tan^{-1}(n+1)x - \tan^{-1}x \\ &= \tan^{-1} \left(\frac{nx}{1 + (n+1)x^2} \right) \end{aligned}$$

$$\begin{aligned} \text{Now, } S_{10}(x) &= \tan^{-1} \left(\frac{10x}{1 + 11x^2} \right) \\ &= \frac{\pi}{2} - \cot^{-1} \left(\frac{10x}{1 + 11x^2} \right) = \frac{\pi}{2} - \tan^{-1} \left(\frac{1 + 11x^2}{10x} \right) \end{aligned}$$

Option (a) is correct.

For option (b)

$$\begin{aligned} \lim_{n \rightarrow \infty} \cot(S_n(x)) &= \cot \left(\tan^{-1} \left(\frac{x}{x^2} \right) \right) \\ &= \cot \left(\tan^{-1} \left(\frac{1}{x} \right) \right) = \cot(\cot^{-1} x) = x, x > 0 \end{aligned}$$

Option (b) is correct.

For option (c)

$$S_3(x) = \frac{\pi}{4} \Rightarrow \frac{3x}{1 + 4x^2} = 1$$

⇒ $4x^2 - 3x + 1 = 0$ has no real root.

Option (c) is incorrect.

For option (d)

For $x = 1$, $\tan(S_n(x)) = \frac{n}{n+2}$ which is greater than $\frac{1}{2}$ for $n \geq 3$.

Option (d) is incorrect.

16. (b and d) Circle $x^2 + y^2 + 5x - 3y + 4 = 0$ cuts the real axis (X-axis) at $(-4, 0)$, $(-1, 0)$.

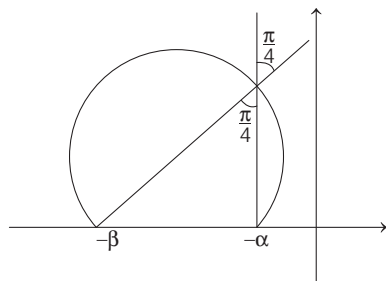

$\arg \left(\frac{z + \alpha}{z + \beta} \right) = \frac{\pi}{4}$ implies z is on arc and $(-\alpha, 0)$ and $(-\beta, 0)$

subtend $\frac{\pi}{4}$ on z .

So, $\alpha = 1$ and $\beta = 4$

Hence, $\alpha\beta = 1 \times 4 = 4$ and $\beta = 4$

17. (4) Given,

$$3x^2 - 4|x^2 - 1| + x - 1 = 0 \quad \dots (i)$$



For $-1 \leq x \leq 1$ i.e., $x \in [-1, 1]$

From Eq. (i), we get

$$\begin{aligned} 3x^2 - 4(-x^2 + 1) + x - 1 &= 0 \\ \Rightarrow 3x^2 + 4x^2 - 4 + x - 1 &= 0 \\ \Rightarrow 7x^2 + x - 5 &= 0 \\ \Rightarrow x &= \frac{-1 \pm \sqrt{1 + 140}}{(2 \times 7)} \end{aligned}$$

Here, both values of x are acceptable.

For $|x| > 1$ i.e. $x \in (-\infty, -1) \cup (1, \infty)$

From Eq. (i), we get

$$\begin{aligned} 3x^2 - 4(x^2 - 1) + x - 1 &= 0 \\ \Rightarrow x^2 - x - 3 &= 0 \\ \Rightarrow x &= \frac{1 \pm \sqrt{1 + 12}}{2} \end{aligned}$$

Again here, both values of x are acceptable.

Hence, total number of solutions is 4.

18. (2) Given, $AB = \sqrt{23} = c$

$$BC = 3 = a$$

$$CA = 4 = b$$

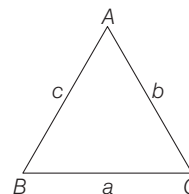

$$\begin{aligned} \text{Now, } \frac{\cot A + \cot C}{\cot B} &= \frac{\frac{\cos A}{\sin A} + \frac{\cos C}{\sin C}}{\frac{\cos B}{\sin B}} \\ &= \frac{\frac{b^2 + c^2 - a^2}{2bc(\sin A)} + \frac{a^2 + b^2 - c^2}{2ab(\sin C)}}{\frac{c^2 + a^2 - b^2}{2ac(\sin B)}} \\ &= \frac{\frac{b^2 + c^2 - a^2}{2bc(\sin A)} + \frac{a^2 + b^2 - c^2}{2ab(\sin C)}}{\frac{c^2 + a^2 - b^2}{2ac(\sin B)}} \\ &= \frac{4\Delta}{c^2 + a^2 - b^2} \cdot \frac{4\Delta}{4\Delta} \\ &= \frac{b^2 + c^2 - a^2 + a^2 + b^2 - c^2}{c^2 + a^2 - b^2} \\ &= \frac{2b^2}{a^2 + c^2 - b^2} = \frac{2 \times 16}{9 + 23 - 16} = \frac{32}{16} = 2 \end{aligned}$$

12 JEE Advanced Solved Paper 2021

19. (7) Given, volume of the parallelepiped = $\sqrt{2}$
i.e. $[\mathbf{u} \ \mathbf{v} \ \mathbf{w}] = \sqrt{2}$, ... (i)

where \mathbf{u} , \mathbf{v} and \mathbf{w} are adjacent sides of parallelepiped.

$$\text{Also, } [\mathbf{u} \ \mathbf{v} \ \mathbf{w}]^2 = \begin{vmatrix} \mathbf{u} \cdot \mathbf{u} & \mathbf{u} \cdot \mathbf{v} & \mathbf{u} \cdot \mathbf{w} \\ \mathbf{v} \cdot \mathbf{u} & \mathbf{v} \cdot \mathbf{v} & \mathbf{v} \cdot \mathbf{w} \\ \mathbf{w} \cdot \mathbf{u} & \mathbf{w} \cdot \mathbf{v} & \mathbf{w} \cdot \mathbf{w} \end{vmatrix} = 2 \text{ (from Eq. (i))}$$

Let $\mathbf{u} \cdot \mathbf{v} = \lambda$ and substitute rest values, we get

$$\begin{vmatrix} 1 & \lambda & 1 \\ \lambda & 1 & 1 \\ 1 & 1 & 4 \end{vmatrix} = 2 \quad [\because \text{given } \mathbf{u} \cdot \mathbf{w} = 1, \mathbf{v} \cdot \mathbf{w} = 1, \mathbf{w} \cdot \mathbf{w} = 4]$$

$$\begin{aligned} \Rightarrow & 4\lambda^2 - 2\lambda = 0 \\ \Rightarrow & \mathbf{u} \cdot \mathbf{v} = 0 \text{ (Rejected)} \\ \text{or} & \mathbf{u} \cdot \mathbf{v} = \frac{1}{2} \\ \therefore & \mathbf{u} \cdot \mathbf{v} = \frac{1}{2} \\ \therefore |3\mathbf{u} + 5\mathbf{v}|^2 &= 9|\mathbf{u}|^2 + 25|\mathbf{v}|^2 + 3 \times 5 \times 2 \times \mathbf{u} \cdot \mathbf{v} \\ &= 9 + 25 + 30 \times \frac{1}{2} \\ &= 49 \quad (\because |\mathbf{u}| = |\mathbf{v}| = 1, \text{ given}) \\ \therefore |3\mathbf{u} + 5\mathbf{v}| &= 7 \end{aligned}$$

Paper 2

1. (a, b and d)

n_1 = number of elements in $S_1 = 10 \times 10 \times 10 = 1000$

n_2 = number of elements in

$$S_2 = 8 + 8 + 7 + 6 + 5 + 4 + 3 + 2 + 1 \\ = 8 + \frac{8 \times 9}{2} = 44 \left(\begin{array}{l} \because 1 \leq i < j + 2 \leq 10 \Rightarrow j \leq 8 \text{ and } i \geq 1 \\ \therefore (i = 1, j = 1, 2, 3, \dots, 8), (i = 2, j = 1, 2, 3, \dots, 8), \\ (i = 3, j = 2, 3, 4, \dots, 8) \text{ and so on} \end{array} \right)$$

$$n_3 = \text{number of elements in } S_3 = {}^{10}C_4 \\ \text{(selecting 4 numbers and arranging in increasing order)} \\ = \frac{10 \times 9 \times 8 \times 7}{24} = 210$$

$$n_4 = \text{number of elements in } S_4 = {}^{10}P_4 = 10 \times 9 \times 8 \times 7 \\ \Rightarrow \frac{n_4}{12} = 420$$

2. (a and b) For option (a) $\cos P = \frac{q^2 + r^2 - p^2}{2qr}$... (i)

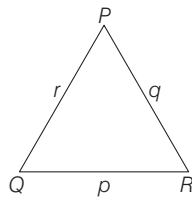

$$\therefore \frac{q^2 + r^2}{2} \geq \sqrt{q^2 r^2} \text{ (AM} \geq \text{GM)}$$

$$\Rightarrow q^2 + r^2 \geq 2qr$$

From Eq. (i), we get

$$\cos P \geq \frac{2qr - p^2}{2qr}$$

$$\Rightarrow \cos P \geq 1 - \frac{p^2}{2qr} \rightarrow \text{option (a) is correct.}$$

For option (b)

$$\frac{(q-r)\cos P + (p-r)\cos Q}{p+q} \\ = \frac{(q\cos P + p\cos Q) - r(\cos P + \cos Q)}{p+q}$$

$$= \frac{r-r(\cos P + \cos Q)}{p+q} = \frac{r-r\cos P - r\cos Q}{p+q}$$

$$= \frac{r-(q-p\cos R) - (p-q\cos R)}{p+q}$$

$$= \frac{(r-p-q) + (p+q)\cos R}{p+q}$$

$$= \cos R + \frac{r-(p+q)}{p+q} \leq \cos R \quad (\because r < p+q)$$

Hence, option (b) is correct.

For Option (c)

$$\frac{q+r}{p} = \frac{\sin Q + \sin R}{\sin P} \geq \frac{2\sqrt{\sin Q \cdot \sin R}}{\sin P}$$

\rightarrow option (c) is incorrect.

For option (d)

If $p < q$ and $p < r$, then p is the smallest side and hence one of Q or R can be obtuse.

So, one of $\cos Q$ or $\cos R$ can be negative.

Therefore, $\cos Q > \frac{p}{r}$ and $\cos R > \frac{p}{q}$ cannot hold always.

Option (d) is incorrect.

3. (a, b and c)

$$\text{Given, } f(0) = 1 \text{ and } \int_0^{\pi/3} f(t) dt = 0$$

For option (a)

Consider a function

$$g(x) = \int_0^x f(t) dt - \sin 3x$$

$g(x)$ is continuous and differentiable function and $g(0) = g(\pi/3) = 0$

\therefore By Rolle's theorem, $g'(x) = 0$ has atleast one solution in $(0, \pi/3)$.

i.e. $g'(x) = f(x) \times 1 - 3\cos 3x = 0$ for some $x \in \left(0, \frac{\pi}{3}\right)$.

For option (b)

Consider a function

$$\phi(x) = \int_0^x f(t) dt + \cos 3x + \frac{6}{\pi}x$$

$\phi(x)$ is continuous and differentiable function as well as $\phi(0) = \phi(\pi/3) = 1$

Hence, by Rolle's theorem, $\phi'(x) = 0$ has atleast one solution in $(0, \pi/3)$.

i.e. $\phi'(x) = f(x) \times 1 - 3\sin 3x + \frac{6}{\pi} = 0$ for some $x \in \left(0, \frac{\pi}{3}\right)$.

For option (c)

$$\text{Let } L = \lim_{x \rightarrow 0} \frac{\int_0^x f(t) dt}{1 - e^{x^2}} \quad \left(\text{form } \frac{0}{0}\right)$$

$$\Rightarrow L = \lim_{x \rightarrow 0} \frac{x f(x) + \int_0^x f(t) dt}{-2x e^{x^2}} \quad (\text{Using L-Hospital Rule})$$

Again, using L'-Hospital rule $\left(\because \text{form } \frac{0}{0}\right)$

$$L = \lim_{x \rightarrow 0} \frac{x f'(x) + f(x) + f(x)}{-4x^2 e^{x^2} - 2e^{x^2}} = \frac{0 + 2f(0)}{-0 - 2} = -1 \quad (\because f(0) = 1)$$

For option (d)

$$\text{Let } P = \lim_{x \rightarrow 0} \frac{\sin x \cdot \int_0^x f(t) dt}{x^2} \quad \left(\text{form } \frac{0}{0}\right)$$

Applying L-Hospital Rule,

$$P = \lim_{x \rightarrow 0} \frac{\sin x \cdot f(x) + \cos x \cdot \int_0^x f(t) dt}{2x} \quad \left(\text{form } \frac{0}{0}\right)$$

Again using L-Hospital Rule,

$$P = \lim_{x \rightarrow 0} \frac{[\cos x \cdot f(x) + \sin x \cdot f'(x) + \cos x \cdot f(x) - \sin x \int_0^x f(t) dt]}{2}$$

$$\Rightarrow P = \frac{1 \times f(0) + 0 \times f'(0) + 1 \times f(0) - 0 \times 0}{2}$$

$$\Rightarrow P = \frac{1 + 0 + 1 - 0}{2} = 1$$

4. (a and c) Given, $\frac{dy}{dx} + \alpha y = x \cdot e^{\beta x}$ which is a linear differential equation.

Integrating factor (IF) = $e^{\int \alpha dx} = e^{\alpha x}$

So, the solution is $y \times e^{\alpha x} = \int x e^{\beta x} \cdot e^{\alpha x} dx$

$$\Rightarrow y \times e^{\alpha x} = \int x e^{(\alpha + \beta)x} dx \quad \dots (i)$$

Case (I) If $\alpha + \beta = 0$

From Eq. (i), we get

$$\Rightarrow y e^{\alpha x} = \int x e^{0 \cdot x} dx = \int x dx = \frac{x^2}{2} + C \quad \dots (ii)$$

Given, $y(1) = 1$ i.e. when $x = 1$, then $y = 1$

From Eq. (ii), we get

$$1 \cdot e^{\alpha} = \frac{1}{2} + C \Rightarrow C = e^{\alpha} - \frac{1}{2}$$

From Eq. (ii), we get

$$y e^{\alpha x} = \frac{x^2 - 1}{2} + e^{\alpha}$$

For $\alpha = 1$

$$y e^x = \frac{x^2 - 1}{2} + e \Rightarrow y = \frac{x^2}{2} e^{-x} + \left(e - \frac{1}{2}\right) e^{-x}$$

Option (a) is correct.

Case (II) If $\alpha + \beta \neq 0$

$$\Rightarrow y e^{\alpha x} = x \cdot \frac{e^{(\alpha + \beta)x}}{(\alpha + \beta)} - \int 1 \times \frac{e^{(\alpha + \beta)x}}{(\alpha + \beta)} dx$$

$$\Rightarrow y e^{\alpha x} = x \cdot \frac{e^{(\alpha + \beta)x}}{(\alpha + \beta)} - \frac{e^{(\alpha + \beta)x}}{(\alpha + \beta)^2} + c_1$$

$$\Rightarrow y = \frac{x \cdot e^{\beta x}}{\alpha + \beta} - \frac{e^{\beta x}}{(\alpha + \beta)^2} + c_1 e^{-\alpha x}$$

(Cancelling $e^{\alpha x}$ from both sides)

$$\Rightarrow y = \frac{e^{\beta x}}{\alpha + \beta} \left(x - \frac{1}{\alpha + \beta}\right) + c_1 e^{-\alpha x} \quad \dots (iii)$$

Putting $\alpha = \beta = 1$ in Eq. (iii), we get

$$y = \frac{e^x}{2} \left(x - \frac{1}{2}\right) + c_1 e^{-x}$$

Given, $y(1) = 1$

$$\therefore 1 = \frac{e}{2} \times \frac{1}{2} + \frac{c_1}{e} \Rightarrow c_1 = e - \frac{e^2}{4}$$

So, $y = \frac{e^x}{2} \left(x - \frac{1}{2}\right) + \left(e - \frac{e^2}{4}\right) e^{-x} \rightarrow$ option (c) is correct.

5. (a, b and c)

Given, $OA = 2\hat{i} + 2\hat{j} + \hat{k}$

$OB = \hat{i} - 2\hat{j} + 2\hat{k}$

and $OC = \frac{1}{2}(OB - \lambda OA)$

Also, $|OB \times OC| = 9/2 \quad \dots (i)$

Now, $OB \times OC = OB \times \frac{1}{2}(OB - \lambda OA)$

$$= \frac{-\lambda}{2} OB \times OA = \frac{\lambda}{2} (OA \times OB)$$

We need to find $OA \times OB$ for this,

($\because a \times b = -b \times a$ and $a \times a = 0$)

$$OA \times OB = \begin{vmatrix} \hat{i} & \hat{j} & \hat{k} \\ 2 & 2 & 1 \\ 1 & -2 & 2 \end{vmatrix}$$

$$= 6\hat{i} - 3\hat{j} - 6\hat{k} = 3(2\hat{i} - \hat{j} - 2\hat{k})$$

So, $OB \times OC = \frac{3\lambda}{2} (2\hat{i} - \hat{j} - 2\hat{k})$

From Eq. (i), $\left|\frac{3\lambda}{2} \sqrt{4+1+4}\right| = 9/2$

$$\Rightarrow \left|\frac{9\lambda}{2}\right| = 9/2 \Rightarrow \frac{9}{2} |\lambda| = \frac{9}{2}$$

$$\Rightarrow |\lambda| = 1 \Rightarrow \lambda = \pm 1$$

But $\lambda > 0$

$\therefore \lambda = 1$

14 JEE Advanced Solved Paper 2021

So, $OC = \frac{1}{2}(OB - OA)$ (By putting $\lambda = 1$)

$$\Rightarrow OC = \frac{1}{2}(-\hat{i} - 4\hat{j} + \hat{k}) = -\frac{1}{2}\hat{i} - 2\hat{j} + \frac{1}{2}\hat{k}$$

Option (a)

$$\begin{aligned} \text{Projection of OC and OA} &= \frac{OC \cdot OA}{|OA|} \\ &= \frac{\frac{1}{2}(-2 - 8 + 1)}{3} = \frac{-3}{2} \end{aligned}$$

Option (b)

$$\begin{aligned} \text{Area of } \Delta OAB &= \frac{1}{2} |OA \times OB| = \frac{1}{2} |OA| |OB| \sin 90^\circ \\ &= \frac{1}{2} |3 \times 3| = \frac{9}{2} \end{aligned}$$

Option (c)

$$\begin{aligned} \text{Area of the } \Delta ABC &= \frac{1}{2} |AB \times AC| \\ &= \frac{1}{2} \left| \begin{vmatrix} \hat{i} & \hat{j} & \hat{k} \\ -1 & -4 & 1 \\ -5/2 & -4 & -1/2 \end{vmatrix} \right| \\ &= \frac{1}{2} |6\hat{i} - 3\hat{j} - 6\hat{k}| = \frac{1}{2} \times 3 \times 3 = \frac{9}{2} \end{aligned}$$

Option (d)

The acute angle between the diagonals of the parallelogram with adjacent sides OA and OC = θ

$$\begin{aligned} \Rightarrow \frac{(OA + OC) \cdot (OA - OC)}{|OA + OC| |OA - OC|} &= \cos \theta \\ \Rightarrow \cos \theta &= \frac{\left(\frac{3}{2}\hat{i} + \frac{3}{2}\hat{k}\right) \cdot \left(\frac{5}{2}\hat{i} + 4\hat{j} + \frac{1}{2}\hat{k}\right)}{\frac{3}{2}\sqrt{2} \times \sqrt{\frac{90}{4}}} \\ &= \frac{18}{3\sqrt{2} \times \sqrt{90}} = \frac{1}{\sqrt{5}} \neq \frac{1}{2} \quad [\because \theta \neq \pi/3] \end{aligned}$$

6. (a, b and d)

Given, $E: y^2 = 8x$... (i)

and $P \equiv (-2, 4)$

Now, directrix of Eq. (i) is $x = -2$

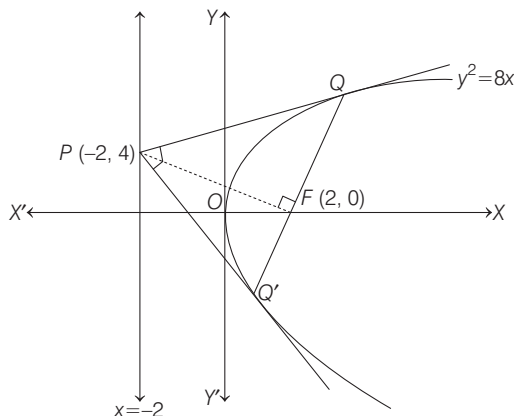

So, point $P(-2, 4)$ lies on the directrix of parabola $y^2 = 8x$.

Hence, $\angle QPQ' = \frac{\pi}{2}$ (by the definition of director circle)

and chord QQ' is a focal chord and segment PQ subtends a right angle at the focus.

Slope of $PF = -1$ ($\because PF \perp QQ'$)

$$\text{Now, slope of } QQ' = \frac{2}{t_1 + t_2} = 1$$

$$\therefore PF = \sqrt{(2+2)^2 + (0-4)^2} = \sqrt{32} = 4\sqrt{2}$$

7. (1.50)

8. (2.00)

Given, $x \geq 0, y^2 \leq 4 - x$

Let equation of circle be

$$(x - h)^2 + y^2 = h^2 \quad \dots (i)$$

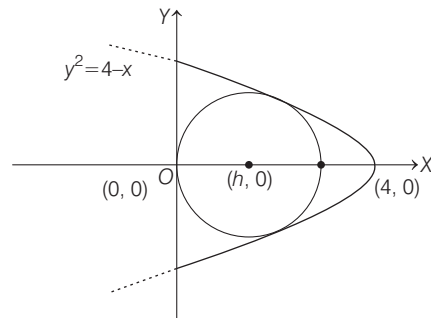

Solving Eq. (i) with $y^2 = 4 - x$, we get

$$x^2 - 2hx + 4 - x = 0$$

$$\Rightarrow x^2 - x(2h + 1) + 4 = 0 \quad \dots (ii)$$

For touching/tangency, Discriminant (D) = 0

$$\text{i.e. } (2h + 1)^2 = 16 \Rightarrow 2h + 1 = \pm 4$$

$$\Rightarrow 2h = \pm 4 - 1$$

$$\Rightarrow h = \frac{3}{2}, h = \frac{-5}{2} \text{ (Rejected) because part of circle lies outside } R.$$

So, $h = \frac{3}{2}$ = radius of circle (c).

Putting $h = 3/2$ in Eq. (ii),

$$x^2 - 4x + 4 = 0 \Rightarrow (x - 2)^2 = 0 \Rightarrow x = 2$$

So, $\alpha = 2$

9. (57)

10. (6)

$$f_1(x) = \int_0^x (t-1)^1 (t-2)^2 (t-3)^3 (t-4)^4 \dots (t-21)^{21} dt$$

$$\Rightarrow f_1'(x) = (x-1)(x-2)^2(x-3)^3(x-4)^4 \dots (x-21)^{21}$$

Sign Scheme for $f_1'(x)$

From sign scheme of $f_1'(x)$, we observe that $f(x)$ has local minima at $x = 4k + 1, k \in W$ i.e. $f_1'(x)$ changes sign from -ve to +ve which are $x = 1, 5, 9, 13, 17, 21$ and $f(x)$ has local maxima at $x = 4k + 3, k \in W$ i.e. $f_1'(x)$ changes sign from +ve to -ve, which are $x = 3, 7, 11, 15, 19$.

So, $m_1 =$ number of local minima points = 6
 and $n_1 =$ number of local maxima points = 5
 Hence, $2m_1 + 3n_1 + m_1n_1 = 2 \times 6 + 3 \times 5 + 6 \times 5 = 57$
 Also, $f_2(x) = 98(x-1)^{50} - 600(x-1)^{49} + 2450$

$$\begin{aligned} \Rightarrow f_2'(x) &= 98 \times 50(x-1)^{49} - 600 \times 49(x-1)^{48} \\ \Rightarrow f_2'(x) &= 98 \times 50(x-1)^{48} (x-1-6) \\ \Rightarrow f_2'(x) &= 98 \times 50(x-1)^{48} (x-7) \end{aligned}$$

Sign scheme for $f_2'(x)$

Clearly, $m_2 = 1$ and $n_2 = 0$

So, $6m_2 + 4n_2 + 8m_2n_2 = 6 + 0 + 0 = 6$

11. (2) $S_1 = \int_{\pi/8}^{3\pi/8} \sin^2 x \cdot 1 \, dx = \int_{\pi/8}^{3\pi/8} \left(\frac{1 - \cos 2x}{2} \right) dx$
 $= \left(\frac{x}{2} - \frac{\sin 2x}{4} \right)_{\pi/8}^{3\pi/8} = \frac{\pi}{8}$
 $\therefore \frac{16S_1}{\pi} = \frac{16}{\pi} \times \frac{\pi}{8} = 2$

12. (1.5) $S_2 = \int_{\pi/8}^{3\pi/8} \sin^2 x |4x - \pi| dx \dots (i)$

$$S_2 = \int_{\pi/8}^{3\pi/8} \sin^2 \left(\frac{3\pi}{8} + \frac{\pi}{8} - x \right) \left| 4 \left(\frac{3\pi}{8} + \frac{\pi}{8} - x \right) - \pi \right| dx$$

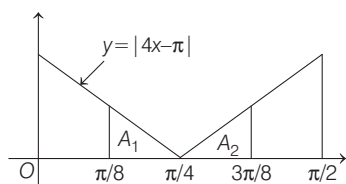

$$\left[\int_a^b f(x) dx = \int_a^b f(a+b-x) dx \right]$$

$\Rightarrow S_2 = \int_{\pi/8}^{3\pi/8} \cos^2 x | \pi - 4x | dx \dots (ii)$

Adding Eqs. (i) and (ii), we get

$$2S_2 = \int_{\pi/8}^{3\pi/8} |4x - \pi| dx$$

From figure,

$$A_1 = \frac{1}{2} \times \frac{\pi}{8} \times \frac{\pi}{4} = \frac{\pi^2}{32} = A_2$$

$\therefore 2S_2 = 2A_1 = \frac{\pi^2}{16} \Rightarrow S_2 = \frac{\pi^2}{32}$

Hence, $\frac{48S_2}{\pi^2} = \frac{48}{32} = \frac{3}{2} = 1.5$

13. (d) $\therefore a_n = \frac{1}{2^{n-1}}$ and $S_n = 2 \left(1 - \frac{1}{2^n} \right)$

For circle C_n to be inside M .

$$S_{n-1} + a_n < \frac{1025}{513} \Rightarrow S_n < \frac{1025}{513}$$

$\Rightarrow 2 \left(1 - \frac{1}{2^n} \right) < \frac{1025}{513} \Rightarrow 1 - \frac{1}{2^n} < \frac{1025}{1026}$

$\Rightarrow 1 - \frac{1}{2^n} < 1 - \frac{1}{1026} \Rightarrow \frac{1}{2^n} < \frac{1}{1026}$

$\Rightarrow \frac{1}{2^n} > \frac{1}{1026} \Rightarrow 2^n < 1026 \Rightarrow n \leq 10$

\therefore Number of circles inside be $10 = k$. Clearly, alternate circle do not intersect each other i.e. C_1, C_3, C_5, C_7, C_9 do not intersect each other as well as C_2, C_4, C_6, C_8 and C_{10} do not intersect each other.

Hence, maximum 5 set of circles do not intersect each other.

$\therefore l = 5$

So, $3k + 2l = 40$

14. (b) $\therefore r = \frac{(2^{199} - 1)\sqrt{2}}{2^{198}}$

Now, $\sqrt{2}s_{n-1} + a_n < \left(\frac{2^{199} - 1}{2^{198}} \right) \sqrt{2}$

$$2\sqrt{2} \left(1 - \frac{1}{2^{n-1}} \right) + \frac{1}{2^{n-1}} < \left(\frac{2^{199} - 1}{2^{198}} \right) \sqrt{2}$$

$\therefore 2\sqrt{2} - \frac{\sqrt{2}}{2^{n-2}} + \frac{1}{2^{n-1}} < 2\sqrt{2} - \frac{\sqrt{2}}{2^{198}}$

$$\frac{1}{2^{n-2}} \left(\frac{1}{2} - \sqrt{2} \right) < -\frac{\sqrt{2}}{2^{198}} \Rightarrow \frac{2\sqrt{2} - 1}{2 \cdot 2^{n-2}} > \frac{\sqrt{2}}{2^{198}}$$

$\Rightarrow 2^{n-2} < \left(2 - \frac{1}{\sqrt{2}} \right) \cdot 2^{197}$

$\therefore n \leq 199$

So, number of circles = 199

15. (c) $\psi_1(x) = e^{-x} + x, x \geq 0$

$$\psi_2(x) = x^2 - 2x - 2e^{-x} + 2, x \geq 0$$

$$f(x) = \int_x^{\infty} (|t| - t^2) e^{-t^2} dt, x > 0$$

$$= 2 \int_0^x (t - t^2) e^{-t^2} dt \dots (i)$$

$$g(x) = \int_0^{x^2} \sqrt{t} \cdot e^{-t} dt, x > 0$$

Put $t = z^2 \Rightarrow dt = 2z dz$

$\therefore g(x) = \int_0^x z \cdot e^{-z^2} \cdot 2z dz$

$$= 2 \int_0^{x^2} z^2 \cdot e^{-z^2} dz = 2 \int_0^x t^2 \cdot e^{-t^2} dt$$

$$f'(x) = 2(x - x^2) e^{-x^2} = 2x(1 - x)e^{-x^2}$$

$\therefore f$ is increasing for $x \in (0, 1)$

and f is decreasing for $x \in (1, \infty)$.

Hence, option (d) is incorrect.

Now, $f(x) + g(x) = 2 \int_0^x t \cdot e^{-t^2} dt$

$$= [-e^{-t^2}]_0^x = (-e^{-x^2}) - (-1) = 1 - e^{-x^2}$$

$\Rightarrow f(x) + g(x) = 1 - e^{-x^2}$

$\therefore f(\sqrt{\ln 3}) + g(\sqrt{\ln 3}) = 1 - e^{-(\sqrt{\ln 3})^2} = 1 - e^{-\ln 3} = 1 - \frac{1}{3} = \frac{2}{3}$

Hence, option (a) is incorrect.

$\therefore \psi_1(x) = e^{-x} + x \dots (iii)$

$\Rightarrow \psi_1'(x) = 1 - e^{-x} < 1$ for $x > 1$

16 JEE Advanced Solved Paper 2021

Then, for $\alpha \in (1, x)$, $\psi_1(x) = 1 + \alpha x$ does not true for $\alpha > 1$.

So, option (b) is incorrect.

$$\text{Now, } \psi_2(x) = x^2 - 2x - 2e^{-x} + 2$$

$$\begin{aligned} \Rightarrow \psi_2'(x) &= 2x - 2 + 2e^{-x} = 2(x + e^{-x}) - 2 \\ &= \psi_2'(x) = 2\psi_1(x) - 2 \quad [\text{from Eq. (iii)}] \end{aligned}$$

By LMVT,

$$\psi_2'(\beta) = \frac{\psi_2(x) - \psi_2(0)}{x - 0}, \text{ for } \beta \in (0, x)$$

$$\Rightarrow \frac{\psi_2(x) - 0}{x - 0} = \psi_2'(\beta) \Rightarrow \psi_2(x) = x \cdot \psi_2'(\beta) = 2x(\psi_1(\beta) - 1)$$

Hence, option (c) is correct.

16. (d) For option (a)

$$\psi_1(x) = e^{-x} + x$$

$$\therefore \psi_1'(x) = 1 - e^{-x} \Rightarrow \psi_1'(x) = 0 \text{ at } x = 0$$

Here, $\psi_1(x)$ is always increasing.

$$\text{Now, } \psi_1(x) > 1$$

$$(\because \psi_1(0) = 1)$$

Thus, option (a) is incorrect.

For option (b)

$$\psi_2(x) = x^2 - 2x - 2e^{-x} + 2$$

$$\Rightarrow \psi_2'(x) = 2x - 2 + 2e^{-x}$$

$$\Rightarrow \psi_2''(x) = 2 - 2e^{-x} \geq 0, \forall x > 0$$

$$\Rightarrow \psi_2'(x) \text{ is increasing} \Rightarrow \psi_2'(x) > \psi_2'(0)$$

$$\Rightarrow \psi_2'(x) > 0, \forall x > 0$$

Thus, option (b) is incorrect.

For Option (c)

$$f(x) = 2 \int_0^x (t - t^2) e^{-t^2} dt = (-e^{-t^2})_0^x - 2 \int_0^x t^2 \cdot e^{-t^2} dt$$

$$= 1 - e^{-x^2} - 2 \int_0^x t^2 \left(1 - t^2 + \frac{t^4}{2!} + \dots \right) dt$$

$$= 1 - e^{-x^2} - \frac{2x^3}{3} + \frac{2x^5}{5} - \frac{2x^7}{2 \cdot 7} + \frac{2x^9}{6 \cdot 9} \dots$$

$$\Rightarrow f(x) - 1 + e^{-x^2} + \frac{2x^3}{3} - \frac{2x^5}{5} < 0 \text{ in } \left(0, \frac{1}{2} \right)$$

Hence, option (c) is also incorrect.

For option (d)

$$g(x) = \int_0^{x^2} \sqrt{t} \cdot e^{-t} dt$$

$$\text{Put } t = u^2 \Rightarrow dt = 2u du$$

$$\therefore g(x) = \int_x^{x^2} 2 \cdot u^2 e^{-u^2} du = \int_0^x 2u^2 \left(1 - u^2 + \frac{u^4}{2!} \dots \right) du$$

$$g(x) = \frac{2x^3}{3} - \frac{2x^5}{5} + \frac{2x^7}{2 \cdot 7} - \frac{2x^9}{9 \cdot 6} \dots$$

$$\Rightarrow g(x) - \frac{2x^3}{3} + \frac{2x^5}{5} - \frac{2x^7}{2 \cdot 7} \leq 0, \forall x \in \left(0, \frac{1}{2} \right)$$

$$\Rightarrow g(x) \leq \frac{2x^3}{3} - \frac{2x^5}{5} + \frac{1}{7} x^7, \forall x \in \left(0, \frac{1}{2} \right)$$

Hence, option (d) is correct.

17. (214)

Given, set = $\{1, 2, 3, \dots, 2000\}$

Let E_1 = Event that it is a multiple of 3 = $\{3, 6, 9, \dots, 1998\}$

$$\therefore n(E_1) = 666$$

and E_2 = Event that it is a multiple of 7

$$= \{7, 14, \dots, 1995\}$$

$$\therefore n(E_2) = 285$$

$E_1 \cap E_2$ = multiple of 21 = $\{21, 42, \dots, 1995\}$

$$n(E_1 \cap E_2) = 95$$

$$\therefore P(E_1 \cup E_2) = P(E_1) + P(E_2) - P(E_1 \cap E_2)$$

$$P(E_1 \cup E_2) = \frac{666 + 285 - 95}{2000} = \frac{856}{2000} = p \text{ (given)}$$

$$\text{Hence, } 500p = 500 \times \frac{856}{2000} = \frac{856}{4} = 214$$

18. (4) As we know that, in a triangle, sides joining the mid-points of two sides is half and parallel to the third side.

$$\therefore M_1 M_2 = \frac{1}{2} QQ'$$

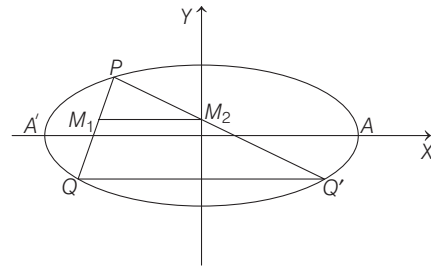

Maximum value of QQ' is AA'

$$\text{Hence, maximum value of } M_1 M_2 = \frac{1}{2} AA' = 4$$

19. (182)

$$\text{Given, } I = \int_0^{10} \left[\sqrt{\frac{10x}{x+1}} \right] dx \quad \dots (i)$$

$$\frac{10x}{x+1} = 1 \Rightarrow 10x = x+1 \Rightarrow x = \frac{1}{9}$$

$$\frac{10x}{x+1} = 4 \Rightarrow 10x = 4x+4 \Rightarrow x = \frac{2}{3}$$

$$\frac{10x}{x+1} = 9 \Rightarrow 10x = 9x+9 \Rightarrow x = 9$$

From Eq. (i), we get

$$\begin{aligned} I &= \int_0^{1/9} \left[\sqrt{\frac{10x}{x+1}} \right] dx + \int_{1/9}^{2/3} \left[\sqrt{\frac{10x}{x+1}} \right] dx + \int_{2/3}^9 \left[\sqrt{\frac{10x}{x+1}} \right] dx \\ &\quad + \int_9^{10} \left[\sqrt{\frac{10x}{x+1}} \right] dx \\ &= \int_0^{1/9} 0 \cdot dx + \int_{1/9}^{2/3} 1 \cdot dx + \int_{2/3}^9 2 \cdot dx + \int_9^{10} 3 \cdot dx \\ &= 0 + [x]_{1/9}^{2/3} + [2x]_{2/3}^9 + [3x]_9^{10} \\ &= \frac{2}{3} - \frac{1}{9} + 18 - \frac{4}{3} + 30 - 27 = 21 - \frac{2}{3} - \frac{1}{9} = \frac{182}{9} \end{aligned}$$

Hence, $9I = 182$